

AD-A147 848

LOW-LOSS FLEXIBLE DIELECTRIC WAVEGUIDE FOR
MILLIMETER-WAVE TRANSMISSION A. (U) CALIFORNIA INST OF
TECH PASADENA W B BRIDGES AUG 84 SRO-005-3

1/1

UNCLASSIFIED

N00014-79-C-0839

F/G 9/1

NL

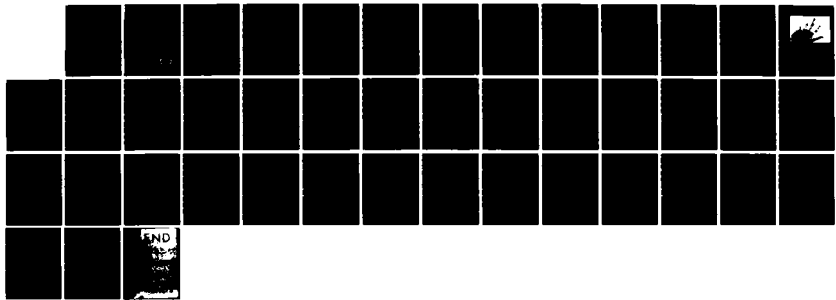

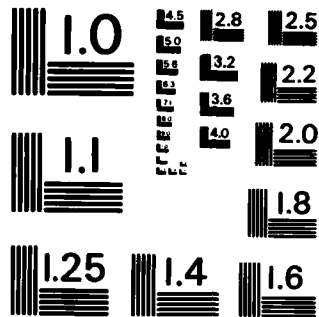

MICROCOPY RESOLUTION TEST CHART
NATIONAL BUREAU OF STANDARDS-1963-A

12

CALIFORNIA INSTITUTE OF TECHNOLOGY

Pasadena, California



Low Loss Flexible Dielectric Waveguide
for Millimeter-Wave Transmission
and its Application to Devices

Final Technical Report SRO-005-3

on

Contract N00014-79-C-0839

Project Number SRO-005

William B. Bridges - Principal Investigator

Reporting Period: 28 February 1982 - 30 September 1983

Prepared for Office of Naval Research, Code 427

Arlington VA 22217

Approved for Public Release

Reproduction, in whole or in part, is permitted for any purpose
of the U.S. Government

DTIC
ELECTE
NOV 28 1984
S E D
E

AD-A147 848

DTIC FILE COPY

84 11 15 001

UNCLASSIFIED

SECURITY CLASSIFICATION OF THIS PAGE (When Data Entered)

REPORT DOCUMENTATION PAGE		READ INSTRUCTIONS BEFORE COMPLETING FORM
1. REPORT NUMBER SRO-005-3	2. GOVT ACCESSION NO. AD-A147848	3. RECIPIENT'S CATALOG NUMBER
4. TITLE (and Subtitle) Low-Loss Flexible Dielectric Waveguide for Millimeter-Wave Transmission and Its Application to Devices		5. TYPE OF REPORT & PERIOD COVERED Final Technical 2/28/82 to 9/30/83
		6. PERFORMING ORG. REPORT NUMBER ONR 84-1
7. AUTHOR(s) William B. Bridges		8. CONTRACT OR GRANT NUMBER(s) N00014-79-C-0839
9. PERFORMING ORGANIZATION NAME AND ADDRESS California Institute of Technology, 128-95 Pasadena, CA 91125		10. PROGRAM ELEMENT, PROJECT, TASK AREA & WORK UNIT NUMBERS 61153N RR 021-02-03
11. CONTROLLING OFFICE NAME AND ADDRESS Office of Naval Research Code 427 Arlington, VA 22217		12. REPORT DATE August 1984
14. MONITORING AGENCY NAME & ADDRESS (if different from Controlling Office)		13. NUMBER OF PAGES
		15. SECURITY CLASS. (of this report) Unclassified
16. DISTRIBUTION STATEMENT (of this Report) Approved for public release; distribution unlimited.		15a. DECLASSIFICATION DOWNGRADING SCHEDULE
		17. DISTRIBUTION STATEMENT (of the abstract entered in Block 20, if different from Report)
18. SUPPLEMENTARY NOTES ONR Scientific Officer: Tel. (202) 696-4218		
19. KEY WORDS (Continue on reverse side if necessary and identify by block number)		
millimeter-waves	loss tangent	nickel aluminum ti- tanate
dielectric waveguides	powdered dielectrics	Ecco-flo
dielectric loss	powdered dielectric waveguides	Teflon
dielectric constant	barium tetratitanate	
	magnesium-calcium titanate	
20. ABSTRACT (Continue on reverse side if necessary and identify by block number)		
Flexible dielectric waveguides have been fabricated for use at 94 GHz and 10 GHz by filling Teflon tubing with high dielectric constant powders. Losses as low as 0.18 dB/cm were measured at 94 GHz with these flexible guides. The theoretical expressions for a round dielectric waveguide with a finite thickness cladding were reviewed, and numerical calculations based on this theory gave good agreement with guide wavelength values measured on the 10 GHz guides. Shorted waveguide measurements at 10 GHz were used to		

DD FORM 1473

1 JAN 73

EDITION OF 1 NOV 65 IS OBSOLETE

S N 0102-LF-014-6601

UNCLASSIFIED

SECURITY CLASSIFICATION OF THIS PAGE (When Data Entered)

UNCLASSIFIED

SECURITY CLASSIFICATION OF THIS PAGE (When Data Entered)

determine dielectric constant as a function of powder density for various low-loss powders: Trans-Tech D-8512 barium tetratitanate, Trans-Tech D-38 barium tetratitanate, Trans-Tech D-30 nickel aluminum titatanate, Trans-Tech MCT-40 magnesium calcium titanate, and Emerson and Cuming Ecco-Flo.

Guide wavelengths were also measured for waveguides made by filling rectangular grooves (approximately 1mm x 1mm) in Teflon substrates with low-loss powders. These measured wavelengths were compared to those predicted by the approximate theory of Marcatili.

S/N 0102-LF-014-6601

UNCLASSIFIED

SECURITY CLASSIFICATION OF THIS PAGE (When Data Entered)

CALIFORNIA INSTITUTE OF TECHNOLOGY

Pasadena, California

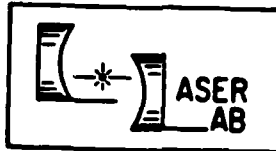

Low Loss Flexible Dielectric Waveguide
for Millimeter-Wave Transmission
and its Application to Devices

Final Technical Report SRO-005-3

on

Contract N00014-79-C-0839

Project Number SRO-005

William B. Bridges - Principal Investigator

Reporting Period: 28 February 1982 - 30 September 1983

Prepared for Office of Naval Research, Code 427

Arlington VA 22217

Approved for Public Release

Reproduction, in whole or in part, is permitted for any purpose
of the U.S. Government



Accession For	
NTIS GRA&I	<input checked="" type="checkbox"/>
DTIC TAB	<input type="checkbox"/>
Unannounced	<input type="checkbox"/>
Justification	
By _____	
Distribution/ _____	
Availability Codes	
Dist	Avail and/or Special
A-1	

This report covers research performed under contract N00014-79-0839 at the California Institute of Technology, Pasadena, California 91125 and, under subcontract, at the Hughes Research Laboratories, Malibu, California 90265 for the final phase of this four year program, 28 February 1982 through 30 September 1983.

Personnel contributing to this work were:

William B. Bridges, Professor of Electrical Engineering and Applied Physics, Caltech; Principal Investigator (818) 356-4809.

Marvin B. Klein, Member of the Technical Staff, Hughes Research Labs, Co-principal Investigator (213) 456-6411 X247.

William M. Bruno, Graduate Student, Caltech (818) 356-4854.

Edgard Schweig, Graduate Student,* Caltech (818) 356-4854.

The authors of each section of the report are identified at the beginning of the section.

* Present address: Millímega S.A.; Los Nogales 777, 6-1501; Lima-27, Perú.

TABLE OF CONTENTS

I.	INTRODUCTION AND SUMMARY	I-1
II.	POWER-FILLED FLEXIBLE CYLINDRICAL WAVEGUIDES	II-1
III.	THEORY OF ROUND DIELECTRIC WAVEGUIDES WITH FINITE CLADDING ...	III-1
IV.	DIELECTRIC CHANNEL WAVEGUIDES	IV-1
	APPENDIX A	A-1

I. INTRODUCTION AND SUMMARY (W. B. Bridges)

A. Summary and Results

The final year of this contract was spent studying a new approach to the realization of a flexible millimeter wave dielectric wave guide. This approach, described briefly in Section I-B, Future Plans, of our Annual Technical Report SRO-005-2, August 1982, involves the use of low loss dielectric in powder form, packed in flexible polymer tubes.

Measurements were undertaken at 94 GHz using various dielectric powders obtained from manufacturers of commercial microwave dielectrics. Since dielectrics are primarily sold in bulk rather than powder form, no data were available from the manufacturers on the dielectric properties of the powders. Thus, we were required to measure them as well as measure the properties of the resulting guides at 94 GHz in order to compare with theory. Measurements were also made at 10 GHz in both teflon tubes and rigid glass tubes to compare experiment with theory for these guides. The results were very encouraging: losses as low as 0.18 dB/cm (18 dB/meter) at 94 GHz were obtained during the final year of the contract. Even lower losses have been obtained subsequently in similar guides. For reference, recall that ordinary W-band copper wave guide has a loss of about 5 dB/meter. Section II of this report summarizes our measurements on flexible waveguides.

One difficulty that was encountered during the flexible waveguide measurements was that of accurately accounting for the effect of the teflon tubing on the guide wavelength. In order to make reasonable comparisons between theory and experiment it proved necessary to review the theory of the three-region circular waveguide, where the cladding is only a fraction to

a few wavelengths thick. (This contrasts with the usual optical fiber, in which the cladding glass is hundreds of wavelength thick, essentially infinite.) Calculations of the guide wavelength were made for the tubing dimensions used and the results checked against experiment. Good agreement was obtained at 10 GHz, so we are confident of our theoretical understanding of this waveguide. The theory of the round guide with finite cladding is summarized in Section III of this report.

Additional experimental difficulties encountered during the measurements on flexible guides had the salutary effect of suggesting a new and interesting application of our powdered core waveguide. The difficulties occurred in attempting to measure the guide wavelength along the curved and rather floppy dielectric-filled teflon spaghetti guides. In addition, the commercially available spaghetti had sufficient variations in wall thickness and ellipticity that we did not completely trust the precision of the measurements. Still another difficulty was encountered in obtaining a uniform packing of the powder in the small tubing. To alleviate all these problems and obtain precise comparison between experiment and theory, we used powder-filled rectangular grooves milled in rigid blocks of dielectric. Teflon and polypropylene were used for these measurements. The open surface of the groove facilitated uniform packing density, and the milled groove provided the dimensional precision and rigidity. Excellent agreement of theory and experiment were obtained. This may seem a bit surprising since the theory available is the approximate theory of Marcatili, not strictly applicable when such large differences in dielectric constant are employed. However, as a result of our previous work [cf. Ref I-1] we were confident that Marcatili's theory gives accurate results even with our large dielectric discontinuities.

These measurements and the comparison with theory are described in Section IV of this report. Waveguide losses as low as 0.1 dB/cm (10 dB/cm) were obtained in such guides of about 1 mm x 1 mm cross section.

The salutary by-product of this work is that the powder-filled groove guide appears to be interesting in its own right. We can envision realizing at 3 mm (or shorter wavelengths) all of the "integrated optics" ideas proposed by Miller [Ref I-2]: directional couplers, resonators, filters, etc. In fact, shortly following the end of this contract, we built a 3 dB directional coupler of the type described by Miller and analyzed by Marcatili [Ref I-3]. Subsequently, we have successfully built ring resonators very similar to those analyzed by Marcatili [Ref I-4] using powder filled grooves; they appear to have Q's similar in magnitude to the Q of the 94 GHz wavemeter (1000). We intend to seek funding to pursue this technique and apply it to more complex filter functions in the future.

B. Publications and Presentations

The following papers and presentations report work accomplished under this contract:

Publications

1. W. B. Bridges, M. B. Klein, and E. Schweig, "Measurement of the Dielectric Constant and Loss Tangent of Thallium Mixed Halide Crystals KRS-5 and KRS-6 at 95 GHz," IEEE Trans. on Microwave Theory and Techniques, Vol. MTT-30, pp. 286-289, March 1982.
2. E. Schweig, "Dielectric Waveguides for Millimeter Waves," Ph. D. Thesis, California Institute of Technology, June 1982
3. M. B. Klein, "Dielectric Waveguide Modulators at 95 GHz Using LiNbO₃," Int. Journal of Infrared and Millimeter Waves, Vol. 3, pp. 587-595, September 1982.

4. M. B. Klein, "Dielectric Waveguide Electrooptic Devices," in *Infrared and Millimeter Waves*, Vol. 9 K. J. Button, Editor, Academic Press, 1983, Chapter 3, pp. 133-175.

5. E. Schweig and W. B. Bridges, "Computer Analysis of Dielectric Waveguides: A Finite-Difference Method," *IEEE Trans. on Microwave Theory and Techniques*, Vol. MTT-32, pp. 531-541, May 1984.

Conference Papers

1. W. B. Bridges, M. B. Klein, and E. Schweig, "Measurement of the Dielectric Constant and Loss Tangent of Thallium Mixed Halide Crystals KRS-5 and KRS-6 at 95 GHz," Paper Th-3-1, Sixth International Conference on Infrared and Millimeter Waves, Miami, Florida, December 1981.

2. E. Schweig and W. B. Bridges, "Computer Analysis of Rectangular Dielectric Waveguide for Millimeter Waves," Paper W-4-4, Sixth International Conference on Infrared and Millimeter Waves, Miami, Florida, December 1981.

3. M. B. Klein, "Electro-Optic Devices in Dielectric Waveguide," Invited Paper W-1-4, Sixth International Conference on Infrared and Millimeter Waves, Miami, Florida, December 1981.

4. W. M. Bruno and W. B. Bridges, "Powder Core Dielectric Waveguides," Paper 22-1, IEEE MTT-S International Microwave Symposium, San Francisco, California, May 30-June 1, 1984

REFERENCES FOR SECTION I

I-1 E. Schwieg and W. B. Bridges, "Computer Analysis of Dielectric Waveguides: A Finite-Difference Method," *IEEE Trans. on Microwave Theory and Techniques*, Vol. MTT-32, pp. 531-541, May 1984.

I-2 S. E. Miller, "Integrated Optics - an Introduction," *Bell System Technical Journal*, Vol. 48, pp 2059-2069, Sept. 1969.

I-3 E. A. J. Marcatili, "Dielectric Rectangular Waveguide and Directional Coupler for Integrated Optics," *Bell System Technical Journal*, Vol. 48, pp. 2017-2102, Sept. 1969.

I-4 E. A. J. Marcatili, "Bends in Optical Dielectric Guides," *Bell System Technical Journal*, pp. 2103-2132, Sept. 1969. Figure 1, page 2105.

II POWDER-FILLED FLEXIBLE CYLINDRICAL WAVEGUIDES (W.M. BRUNO)

A. SUMMARY

Flexible dielectric waveguides have been demonstrated at 10 Ghz and 94 Ghz by filling hollow, low-dielectric-constant polymer tubes with low-loss, high-dielectric-constant powders. Flexible guides with losses as low as 0.18 dB/cm were demonstrated at 94 Ghz. These guides also exhibited negligible bending loss for radii of curvature greater than 4 cm. Figure II-1 is a photograph of some samples of W-band flexible guide made by this technique.

B. 10 GHZ MODELING EXPERIMENTS

Initial efforts to make dielectric waveguides by filling flexible hollow tubes with dielectric powders were conducted at 10 Ghz to avoid complications due to the small guide dimensions at 94 Ghz. In addition, the dielectric properties of the powders were known at 10 Ghz, so the guides could actually be "designed" and compared with theory.

The powders used were Emerson and Cuming ecco-flo powder, Trans-Tech D-30 nickel-aluminum titanate, and Trans-Tech D-38 barium tetratitanate. The particles of the D-30 and D-38 powders ranged in size from 43 μm to 100 μm . Trans-Tech gives $\epsilon' = 34$ and $\tan\delta < .0002$ for solid D-30 at 10 Ghz, and $\epsilon' = 37$ and $\tan\delta < .0005$ for solid D-38 at 6 Ghz. Ecco-flo powder is specified by Emerson and Cuming to have $\tan\delta = .0007$ at 10 Ghz.

In order to design a dielectric waveguide with a powder core, it is necessary to know how the dielectric constant of the powder varies with the packing density. This relationship was determined for each powder at 10 Ghz



Figure II-1: Samples of W-band dielectric waveguide made by filling teflon spaghetti with various low-loss dielectric powders

by using the shorted waveguide technique [Ref. II-1] to measure dielectric constant. A plot of dielectric constant versus density for nickel-aluminum titanate is given in Fig. II-2.

The tubing materials used were TFE teflon, polyethylene, and Corning 7740 glass (pyrex[®]). The dielectric properties of these materials at 10 Ghz as given by Von Hippel [Ref. II-2] are shown in Table II-1. Although the pyrex tubes were inflexible, they were useful for making guide wavelength and attenuation measurements.

Each waveguide was made by filling a tube with powder and plugging the ends with polyfoam. The inner diameter of the tube was picked so that the HE_{11} mode would propagate with a wavelength significantly smaller than the free space wavelength. Coupling was achieved by inserting one end of the tube into a metal TE_{10} -rectangular to TE_{11} -circular waveguide transition. (The metal waveguide transition was used since the transverse fields of the TE_{11} circular mode of metal waveguide [Ref. II-3] are known to be similar to those of the HE_{11} mode of a cylindrical dielectric rod.) The waveguide was supported inside the coupler by a polyfoam insert. With the waveguide inserted to the proper depth (determined by trial and error), the coupling was good, and there was no detectable radiation field away from the coupler and waveguide. A metal perturber placed a few mm away from the fiber, outside the volume of the (HE_{11}) guided mode caused no change in reflected power. Finally, lossy foam was wrapped around the tube at the far end to prevent reflections.

Guide wavelength measurements were made by sliding a metal washer along the length of the guide and observing the periodic variation in reflected power. Table II-2 shows that the measured guide wavelengths were in excellent agreement with those predicted by the theory of lossless 3-region

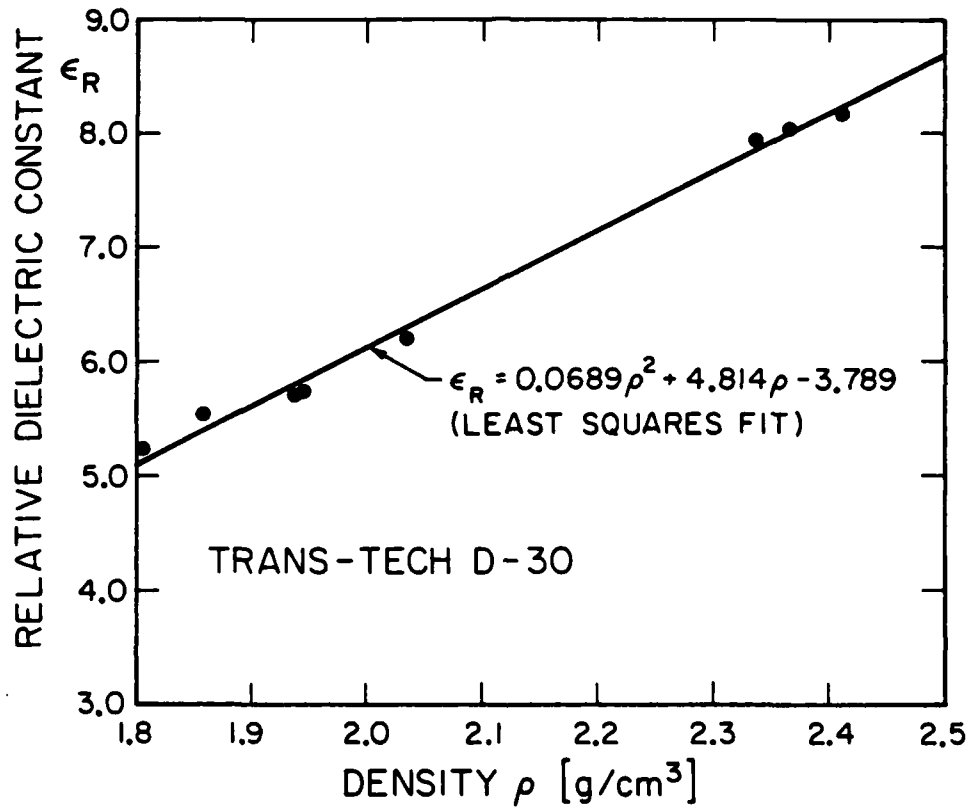

Figure II-2: Relative dielectric constant versus density for Trans-Tech D-30 powder

TABLE II-1

Dielectric Properties of Tubing Materials at 10 GHz

MATERIAL	ϵ'_r	$\tan \delta$
TFE teflon	2.08	.0004
polyethylene	2.25	.0004
Corning 7740 pyrex [®] glass	4.52	.0085

Data from A. R. Von Hippel, DIELECTRIC MATERIALS AND APPLICATIONS, John Wiley and Sons, Inc., pp. 301-370, New York, 1958.

TABLE II-2

Comparison of measured guide wavelength to that predicted for the three-region HE_{11} mode

core radius (cm)	cladding radius (cm)	freq. (Ghz)	core material	$\epsilon_{r\text{core}}$	cladding material	$\epsilon_{r\text{clad}}$	measured guide wavelength (cm)	predicted HE_{11} guide wavelength (cm)
0.33	0.45	10.000	1	7.62	A	4.52	2.05	2.06
0.25	0.35	10.000	2	13.45	A	4.52	2.30	2.19
0.26	0.30	10.000	2	11.40	B	2.08	2.88	2.86
0.26	0.30	11.311	2	11.40	B	2.08	2.14	2.09
0.30	0.40	10.940	2	13.02	C	2.25	1.38	1.32
0.32	0.47	9.794	2	12.39	C	2.25	1.71	1.65

Material 1 is nickel-aluminum titanate (Trans-Tech D-30).
 Material 2 is Emerson and Cuming Ecco-flo powder.
 Material A is Corning 7740 pyrex[®] glass.
 Material B is TFE teflon.
 Material C is polyethylene.

cylindrical dielectric waveguide, as presented in Sec. III of this report. The values of $\epsilon_{r_{\text{core}}}$ listed in Table II-2 were determined by using the ϵ_r vs. density data and determining the density of the powder in the tube by precision weight measurement.

We expected that the field distribution of the HE_{11} -like mode of a three-region guide would resemble that of the HE_{11} mode of a simple dielectric rod. To test this hypothesis, the fields of the HE_{11} mode of a rod were perturbed with a small wire as shown in Fig. II-3. Placing the wire in position A caused virtually no reflection, and probing in position C had only a slightly greater effect. Placing the wire at B caused a large reflection exceeded only by that created with the wire in position D. These observations are consistent with the degree to which a wire probe would short the electric field of the HE_{11} mode of a dielectric rod. When the fields of the lowest order mode of a powder-filled tube were tested with a wire, the results were the same. Thus we conclude that the transverse field distribution of the lowest order mode of a 3-region cylindrical dielectric waveguide is similar to that of the HE_{11} mode of a dielectric rod.

Rough estimates of transmission and bending loss were obtained for the powder-filled tubes by observing the exponential decay in reflected power as a metal washer was moved along the length of the guide. These measurements indicated that the transmission and bending losses were low. Since we were primarily interested in millimeter-wave guides, we did not pursue this investigation far enough to determine precisely the magnitude of these losses. Instead we began a program to build and test flexible 94 Ghz powder-filled tube waveguides.

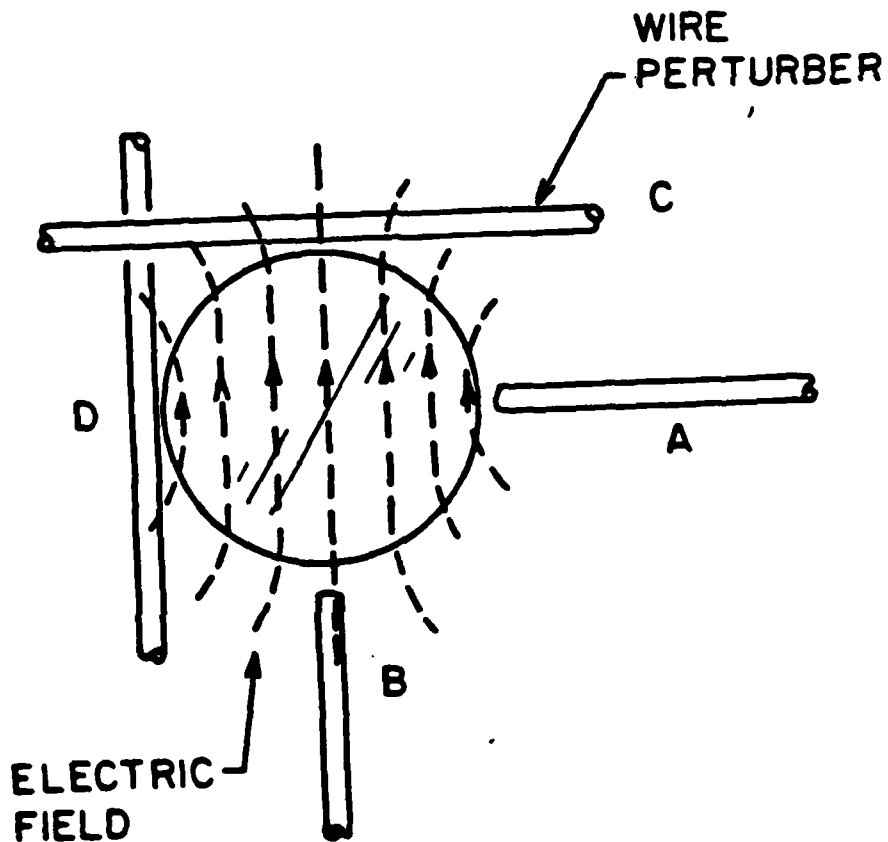

Figure II-3: Cross-section of the dielectric rod showing four positions of a metal wire perturber. The electric field lines are sketched in for the HE_{11} mode in a particular plane; beyond the plane shown the electric field lines run parallel to the rod along the outside, then turn back into the fiber one half guide wavelength away, reproducing the pattern shown, but in the opposite sense

C. 94 GHZ EXPERIMENTS

94 Ghz flexible dielectric waveguides were made by filling lightweight teflon tubes (18,19,20,21 AWG electrical spaghetti) with dielectric powders. Coupling to metal waveguide was achieved by inserting the end of the tube into a slightly flared section of W-band waveguide.

As before, guide wavelength measurements were made by sliding a metal perturber along the length of the waveguide and observing the periodic variation in reflected power. Unlike the measurements done at X-band, the wavelengths measured at 94 Ghz did not agree well with theoretical predictions. We believe that one of the factors contributing to the discrepancy between measurement and theory was the random variation with length of the cross-sectional dimensions and circularity of the tubing. Another source of error was that the small size of the tubes made it difficult to fill them uniformly with powder. Packing irregularities caused the observed guide wavelength to vary with position along the waveguide. Finally, the powder-filled tubes were so flexible they would bend during the measurement, making the wavelength measurement difficult to perform accurately.

The ecco-flo powder proved to be so lossy at 94 Ghz that only surface waves would propagate along teflon tubes filled with this powder. These waves were the same kind of $v \approx c$ waves that were previously observed on KRS-5 guides. However, guides made with the D-30 and D-38 powders propagated waves which were significantly slowed. Two powders not received in time to be studied at X-band were also tried as core materials at 94 Ghz. These substances were Trans-Tech MCT-40 magnesium-calcium titanate and D-8512, an improved barium tetratitanate.

We have determined that D-8512 has lower mm-wave loss than D-38, and Trans-Tech claims that D-8512 also has a smaller thermal coefficient of dielectric constant. Guides made with these powders also had guide

wavelengths significantly shorter than the free space wavelength, as expected for guided modes.

Attenuation measurements were made by measuring the power received with a diode detector at the far end of the waveguide. Power was coupled off the dielectric waveguide by inserting it into an identical flared section of metal waveguide connected to the detector. Another detector connected to a small horn was used as a movable probe to determine that there was an insignificant amount of radiation from the couplers and waveguide. Also, the power reflected back into the metal waveguide from the feed coupler was approximately -20 dB down from the incident power. Finally, guides which differed in length but were otherwise identical had losses which scaled with length. Thus, we concluded that there was very little power lost in coupling by reflection or radiation, so that the difference between the incident power and the power detected at the far end represented the true dielectric waveguide loss. The loss per unit length is then this loss divided by the length of the dielectric waveguide. Table II-3 gives the results of attenuation measurements on a few straight powder-filled teflon tubes. In general, guides with D-30 or D-38 powder cores exhibited losses of approximately 0.4 dB/cm. Losses for guides made with MCT-40 were near 0.3 dB/cm and losses for guides using D-8512 powder were around 0.2 dB/cm.

Bending loss measurements were made using the same set-up as for attenuation measurements on straight guides. Bending the dielectric waveguides into arcs with radii of curvature as small as 4 cm caused no measurable additional loss. One problem encountered during these measurements was that the ends of the teflon tubes tended to change position inside the flared metal waveguide couplers when the tubes were bent. This movement would change the quality of the coupling between the dielectric

TABLE II-3

Attenuation of straight powder-filled teflon tubes

powder	core radius (mm)	cladding radius (mm)	freq. (Ghz)	$\epsilon_{r \text{ core}}$	measured guide wavelength (mm)	loss (dB/cm)
1	0.53	0.61	94.30	8.41	1.90	0.36
2	0.53	0.61	94.08	4.48	2.12	0.26
3	0.53	0.61	94.10	4.79	2.06	0.18

$\lambda_0 = 3.18 \text{mm}$

Powder 1 is nickel-aluminum titanate (Trans-Tech D-30).

Powder 2 is magnesium-calcium titanate (Trans-Tech MCT-40).

Powder 3 is barium tetra-titanate (Trans-Tech D-8512).

waveguide and the metal waveguides.

These difficulties in measuring bending loss and the desire to obtain good agreement between theory and experiment at 94 Ghz so that we could be confident of our values of guide wavelength and attenuation prompted us to abandon the flexible guide measurements and explore a rigid guide. We adopted a powder-filled open channel in a solid block of polymer. This configuration satisfied both the requirement of rigidity so that we could make precise length measurements and the requirement of uniformity, since the powder was loaded from the side rather than the end of the guide. The initial phase of this work is described in Sec. IV. Unfortunately, the contract expired before we could complete these measurements and return to the flexible guide studies.

REFERENCES

- II-1. S. Roberts and A.R. von Hippel, "A New Method for Measuring Dielectric Constant and Loss Tangent in the Range of Centimeter Waves", J. Appl. Phys., Vol. 17, p. 610-616, July 1946.
- II-2. A.R. von Hippel, DIELECTRIC MATERIALS AND APPLICATIONS, John Wiley and Sons, Inc., pp. 301-370, New York, 1958.
- II-3. S. Ramo, J.R. Whinnery, and T. Van Duzer, FIELDS AND WAVES IN COMMUNICATION ELECTRONICS, Wiley, New York, 1966, pp. 432.

III THEORY OF ROUND DIELECTRIC WAVEGUIDES WITH FINITE CLADDING

(W.M. Bruno)

A. Introduction

In order to design a waveguide, one must know how changes in the waveguide parameters will affect the number of propagating modes and the corresponding guide wavelengths. This information is contained in the characteristic equation.

The characteristic equation for a lossless 3-region cylindrical dielectric waveguide was first derived by M.H. Kuhn in 1974 [Ref. III-1]. We have solved this equation numerically for several different cases of interest for the teflon, polyethylene, and glass-clad powder-core waveguides studied experimentally and described in Section II. In this section, we review briefly Kuhn's theory and give results in graphical form for the cases of interest.

B. The Characteristic Equation

The geometry of a 3-region cylindrical dielectric waveguide is shown in Fig. III-1. Region 1 is the core of the waveguide, and region 2 is the cladding. The exterior region 3 was taken to be air ($\epsilon_{r_3} = 1$). Since the materials are assumed to be lossless in this first order analysis, ϵ_{r_1} and ϵ_{r_2} are real. It should be possible to develop the corresponding equation when the 3 regions have finite loss, but solving the resulting equation would be substantially more difficult. To our knowledge no one has attempted this task. For low-loss guide, it is usually sufficient to treat the loss as a perturbation, that is, ignore its effect on $\beta(\omega)$.

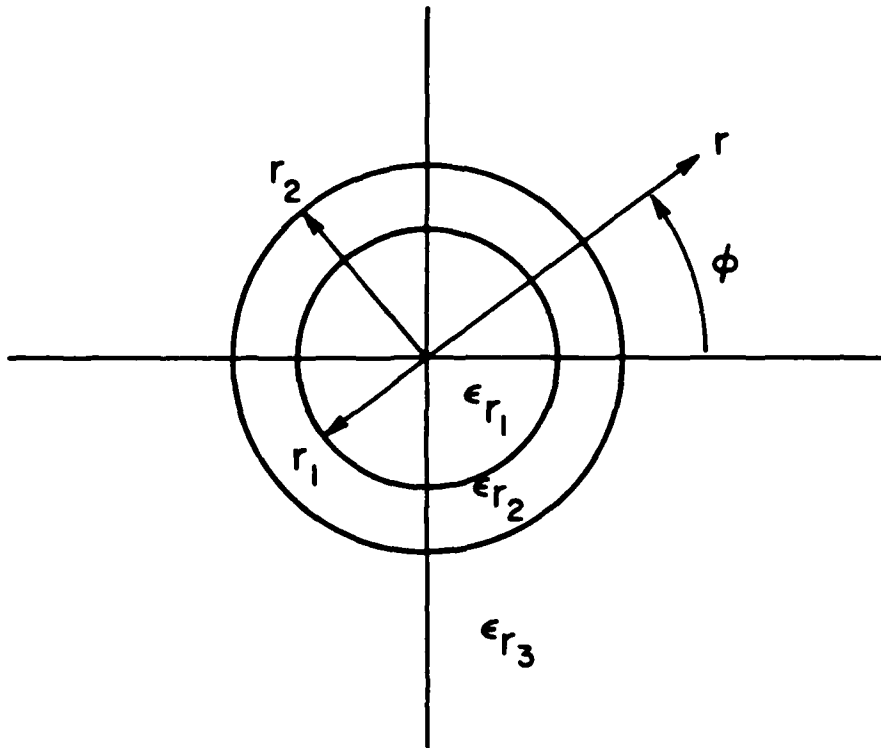

Figure III-1: Cross-section of 3-region cylindrical dielectric waveguide

Propagating modes may be classified as either "core" modes or "cladding" modes [Ref. III-1]. If the propagation constant, β , of a mode satisfies $\beta > \sqrt{\epsilon_{r_2}} k_0$ where $k_0 = \omega \sqrt{\mu_0 \epsilon_0}$, then the mode is a core mode. Core modes propagate with phase velocities less than $c/\sqrt{\epsilon_{r_2}}$ but greater than $c/\sqrt{\epsilon_{r_1}}$. On the other hand, modes for which $\beta < \sqrt{\epsilon_{r_2}} k_0$ are called cladding modes. These modes have phase velocities less than $c/\sqrt{\epsilon_{r_3}}$ but greater than $c/\sqrt{\epsilon_{r_2}}$. In general, cladding modes have larger phase velocities than core modes because a larger fraction of the power of a cladding mode propagates outside the core of the waveguide. For any propagating mode, $k_0 \leq \beta \leq \sqrt{\epsilon_{r_1}} k_0$. Modes with values of β lying outside this interval are cutoff [Fig III-2].

Consider a system of cylindrical coordinates as shown in Fig. III-1 with the z-direction coinciding with the longitudinal axis of the waveguide. The z components of the fields of a core mode can be found using separation of variables. They are

$$\begin{aligned}
 E_{1z} &= AJ_m(k_1 r) \cos(m\phi) \exp(-j\beta z + j\omega t) \\
 H_{1z} &= BJ_m(k_1 r) \sin(m\phi) \exp(-j\beta z + j\omega t) \\
 E_{2z} &= [CI_m(k_2 r) + DK_m(k_2 r)] \cos(m\phi) \exp(-j\beta z + j\omega t) \\
 H_{2z} &= [EI_m(k_2 r) + FK_m(k_2 r)] \sin(m\phi) \exp(-j\beta z + j\omega t) \\
 E_{3z} &= GK_m(k_3 r) \cos(m\phi) \exp(-j\beta z + j\omega t) \\
 H_{3z} &= PK_m(k_3 r) \sin(m\phi) \exp(-j\beta z + j\omega t)
 \end{aligned} \tag{III-1}$$

Here m is the azimuthal eigenvalue, A, B, C, D, E, F, G, and P are constants and

$$\begin{aligned}
 k_1 &= \sqrt{\epsilon_{r_1} k_0^2 - \beta^2} \\
 k_2 &= \sqrt{\beta^2 - \epsilon_{r_2} k_0^2} \\
 k_3 &= \sqrt{\beta^2 - \epsilon_{r_3} k_0^2}
 \end{aligned} \tag{III-2}$$

The remaining radial and azimuthal field components can be expressed

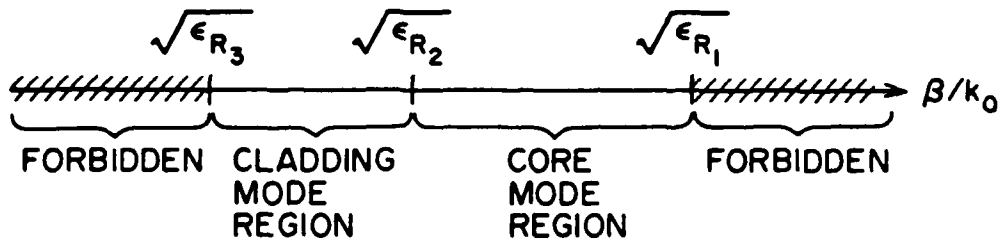

Figure III-2: Classification of modes of a 3-region cylindrical dielectric waveguide

in terms of the z-components using Maxwell's curl equations. (See, for example, Ref. III-2 or III-3.) These field components will exhibit similar functional variations with (r, ϕ, z) as the z-components in each region since they are related to the z-components by differentiation. Note that for the "core" modes, the z-components of the electric and magnetic fields are oscillatory with r in the core region (Bessel function J_m), smoothly varying in the cladding region (modified Bessel functions I_m, K_m) and decaying-exponential-like in the exterior region (K_m only).

By contrast, for a "cladding" mode, the constant k_2 becomes

$$k_2 = \sqrt{\epsilon_{r_2} k_0^2 - \beta^2} \quad (\text{III-3})$$

while k_1, k_3 remain as before, and the field components E_{2z}, H_{2z} become

$$E_{2z} = [C'J_m(k_2 r) + D'Y_m(k_2 r)] \cos(m\phi) \exp(-j\beta z + j\omega t)$$

$$H_{2z} = [E'J_m(k_2 r) + F'Y_m(k_2 r)] \sin(m\phi) \exp(-j\beta z + j\omega t)$$

The z-components of the fields in regions 1 and 3 retain the same forms as for core modes.

Equating the tangential field components at the boundaries between regions yields a set of eight linear homogeneous equations for the eight constants (A, B, C, ..., P.). Setting the secular determinant of this system to zero yields the characteristic equation. The characteristic equation for core modes may be written [Ref. III-4]

$$G_1 \eta_1^2 + G_2 \eta_1 + G_3 = 0 \quad (\text{III-5})$$

where

$$G_1 = ad - bc$$

$$G_2 = (ad' - cb') + (da' - bc')$$

$$G_3 = a'd' - b'c'$$

$$\begin{aligned}
 a &= \epsilon_{r_1} (\epsilon_{r_2} \Delta_2 - \epsilon_{r_3} \Delta_5) \\
 a' &= \epsilon_{r_2} Q_1 Q_2 (\xi - 1) - \epsilon_{r_2} (\epsilon_{r_2} \Delta_3 + \epsilon_{r_3} \Delta_1 \eta_6) \\
 b &= \epsilon_{r_2} (\xi - 1) Q_2 \\
 b' &= Q_1 (\epsilon_{r_2} \Delta_2 - \epsilon_{r_3} \Delta_5) + \epsilon_{r_2} \Delta_1 Q_2 \\
 c &= \epsilon_{r_1} (\xi - 1) Q_2 \\
 c' &= \epsilon_{r_2} Q_1 (\Delta_2 - \Delta_5) + \epsilon_{r_2} \Delta_1 Q_2 \\
 d &= \epsilon_{r_2} (\Delta_2 - \Delta_5) \\
 d' &= Q_1 Q_2 (\xi - 1) - \epsilon_{r_2} (\Delta_3 + \Delta_1 \eta_6)
 \end{aligned}$$

$$\Delta_1 = \eta_2 - \xi \eta_3$$

$$\Delta_2 = \xi \eta_4 - \eta_5$$

$$\Delta_3 = \xi \eta_3 \eta_4 - \eta_2 \eta_5$$

$$\Delta_4 = \xi (\eta_2 - \eta_3) (\eta_4 - \eta_5)$$

$$\Delta_5 = (\xi - 1) \eta_6$$

$$\eta_1 = J'_m(x) / x J_m(x)$$

$$\eta_2 = -I'_m(u_1) / u_1 I_m(u_1)$$

$$\eta_3 = -K'_m(u_1) / u_1 K_m(u_1)$$

$$\eta_4 = -I'_m(u_2) / u_2 I_m(u_2)$$

$$\eta_5 = -K'_m(u_2) / u_2 K_m(u_2)$$

$$\eta_6 = -K'_m(w) / w K_m(w)$$

$$\xi = I_m(u_2) K_m(u_1) / I_m(u_1) K_m(u_2)$$

$$Q_1 = (m\beta/k_0) (1/x^2 + 1/u_1^2)$$

$$Q_2 = (m\beta/k_0) (1/w^2 - 1/u_2^2)$$

$$x = r_1 \sqrt{k_0^2 \epsilon_{r_1} - \beta^2}$$

$$u_1 = r_1 \sqrt{\beta^2 - k_0^2 \epsilon_{r_2}}$$

$$u_2 = u_1 r_2 / r_1$$

$$w = r_2 \sqrt{\beta^2 - k_0^2 \epsilon_{r_3}}$$

(III-6)

For cladding modes,

$$\eta_2 = J'_m(u_1) / u_1 J_m(u_1)$$

$$\eta_3 = Y'_m(u_1) / u_1 Y_m(u_1)$$

$$\eta_4 = J'_m(u_2) / u_2 J_m(u_2)$$

$$\eta_5 = Y'_m(u_2) / u_2 Y_m(u_2)$$

$$\xi = J_m(u_2) Y_m(u_1) / J_m(u_1) Y_m(u_2)$$

(III-7)

$$Q_1 = (m\beta/k_0)(1/x^2 - 1/u_1^2) \quad Q_2 = (m\beta/k_0)(1/u_2^2 + 1/w^2)$$

$$u_1 = r_1 \sqrt{k_0^2 \epsilon_{r_2} - \beta^2}$$

As in the case of a simple 2-region dielectric rod, when the azimuthal eigenvalue, m , equals zero, the left hand side of the characteristic equation can be factored, producing two equations. These are

$$\epsilon_{r_1} \eta_1 (\epsilon_{r_2} \Delta_2 - \epsilon_{r_3} \Delta_5) - \epsilon_{r_2}^2 \Delta_3 - \epsilon_{r_2} \epsilon_{r_3} \Delta_1 \eta_6 = 0 \quad (\text{III-9})$$

which yields TM modes, and

$$\eta_1 (\Delta_2 - \Delta_5) - \Delta_3 - \Delta_1 \eta_6 = 0 \quad (\text{III-10})$$

which yields TE modes. Since $m = 0$ the fields of these modes have no circumferential variation. TM and TE modes are designated TM_{01} , TM_{02} , TM_{03} , ... and TE_{01} , TE_{02} , ... where the first subscript specifies $m = 0$ (redundant) and the second gives the order in which the mode goes through cutoff to become a guided mode.

Again, as in the case of the simple dielectric rod, all modes for which m is not zero are termed "hybrid" modes. Several methods have been proposed [Refs. III-1, III-4 - III-9] for classifying hybrid modes for 2 and 3 region guide but none has been universally accepted. Most schemes classify hybrid modes into one of two categories, HE_{mn} and EH_{mn} , according to the relative sizes of E_z and H_z : HE for $\sqrt{\mu_1/\epsilon_1} |H_z| \gg |E_z|$ and EH for $|E_z| \gg \sqrt{\mu_1/\epsilon_1} |H_z|$. The first subscript specifies the azimuthal eigenvalue and the second specifies the order in which the mode goes through cutoff. The fundamental mode of the 3-region cylindrical dielectric waveguide is also called the HE_{11} mode and has no non-zero cutoff frequency, just as the 2-region HE_{11} .

C. Numerical Results

A computer program to evaluate the characteristic equation numerically for modes with $m = 1$ was used to design 3-region cylindrical dielectric waveguides. Using the dispersion curves generated by this program, the core radius was picked so that the HE_{11} mode propagated with a phase velocity significantly slower than that of free space. Examples of the computed values for propagation constant for different parameters appropriate to the 10-GHz experiments were given in Sec. II. As reported in that section, the agreement between theoretical and experimental values was excellent.

Numerically obtained dispersion curves for the HE_{11} mode at 94 GHz are given in Fig. III-3 for three values of $\epsilon_{r_{\text{core}}}$. In each case $\epsilon_{r_{\text{clad}}}$ is 2.08 and the cladding thickness is 0.15mm. (These parameters correspond to "lightweight" TFE teflon tubing.)

REFERENCES

- III-1. M.H. Kuhn, "The influence of the refractive index step due to the finite cladding of homogeneous fibers on the hybrid properties of of modes," Archiv fur Elektronik und Ubertragungstechnik, vol. 28, pp. 393-401, October, 1974.
- III-2. S. Ramo, J.R. Whinnery, and T. Van Duzer, FIELDS AND WAVES IN COMMUNICATION ELECTRONICS, Wiley, New York, 1966, Chapter 7.
- III-3. H.G. Unger, PLANAR OPTICAL WAVEGUIDES AND FIBERS, Clarendon Press, Oxford, 1977, Chapter 4.
- III-4. A. Safaai-Jazi and G.L. Yip, "Classification of hybrid modes in cylindrical dielectric optical waveguides," Radio Science, vol. 12, pp 603-609, July-August, 1977.

- III-5. R.E. Beam, M.M. Astrahan, W.C. Jakes, H.M. Wachowski, and W.L. Firestone, "Dielectric tube waveguides," Rep. ATI 94929, chap. 5, Northwestern University, Evanston, Illinois, 1949.
- III-6. P.J.B. Clarricoats, "Propagation along unbounded and bounded dielectric rods," Proc. Inst. Elec. Eng., vol. 108C, pp 170-176, 1961.
- III-7. P.J.B. Clarricoats, and K.B. Chan, "Propagation behaviour of cylindrical dielectric-rod waveguides," Proc. Inst. Elec. Eng., Vol. 120, pp 1371-1378, Nov. 1973.
- III-8. M.M.Z. Kharadly, and J.E. Lewis, "Properties of dielectric tube waveguides," Proc. Inst. Elec. Eng., Vol. 116, pp 214-224, Feb. 1969.
- III-9. E. Snitzer, "Cylindrical dielectric waveguide modes," J. Opt. Soc. Amer., Vol 51, pp 491-498, May 1961.

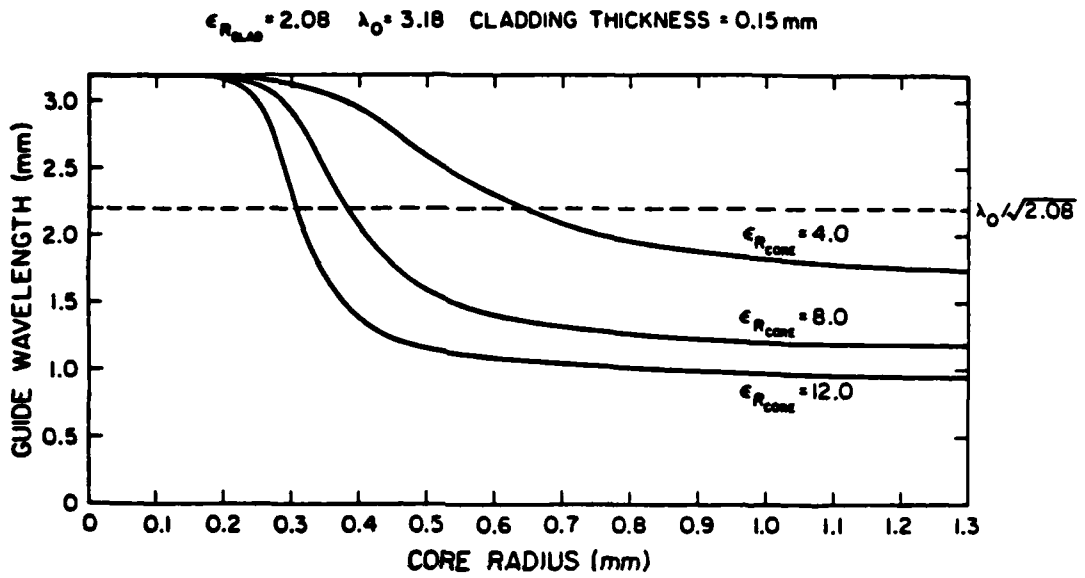

Figure III-3: HE₁₁ mode of 3-region cylindrical dielectric waveguide for different values of $\epsilon_{r_{core}}$

IV DIELECTRIC CHANNEL WAVEGUIDES (W.M. Bruno and W.B. Bridges)

In order to avoid the difficulty of packing powder uniformly into thin tubes, rectangular channels milled into the surface of dielectric substrates were filled with powder to make mm-wave dielectric waveguides. Although this technique was originally undertaken for ease in making guide wavelength and attenuation measurements as mentioned in Sec. II, this type of waveguide appears to be an attractive medium for low-cost, complex mm-wave components and integrated circuits.

Figure IV-1 shows schematically a rectangular groove milled into the surface of a dielectric substrate and filled with a high dielectric constant powder to form the core of a dielectric waveguide. With this configuration, the powder could be packed from the top to assure a sufficiently uniform density along the length of the channel. Rectangular channels with cross-sectional dimensions varying less than 0.001 inches from the specified values could be milled with relative ease. This degree of dimensional accuracy was found to be sufficient at 94 GHz to produce a guide wavelength uniform within our measurement accuracy.

Guide wavelengths were measured for the fundamental vertically polarized mode of various powder-filled rectangular channel waveguides using the set-up shown in Fig. IV-2. On one end of the substrate the dielectric-filled channel was extended with a thin-walled trough of substrate material. This trough fitted snugly into the end of a slightly flared section of metal waveguide to couple to the dielectric guide.

To measure the guide wavelength, a metal perturber was held mechanically just above the surface of the powder. This perturber reflects a small fraction of the power travelling along the waveguide toward the feed, where it interferes with the reflection from the input coupler. The

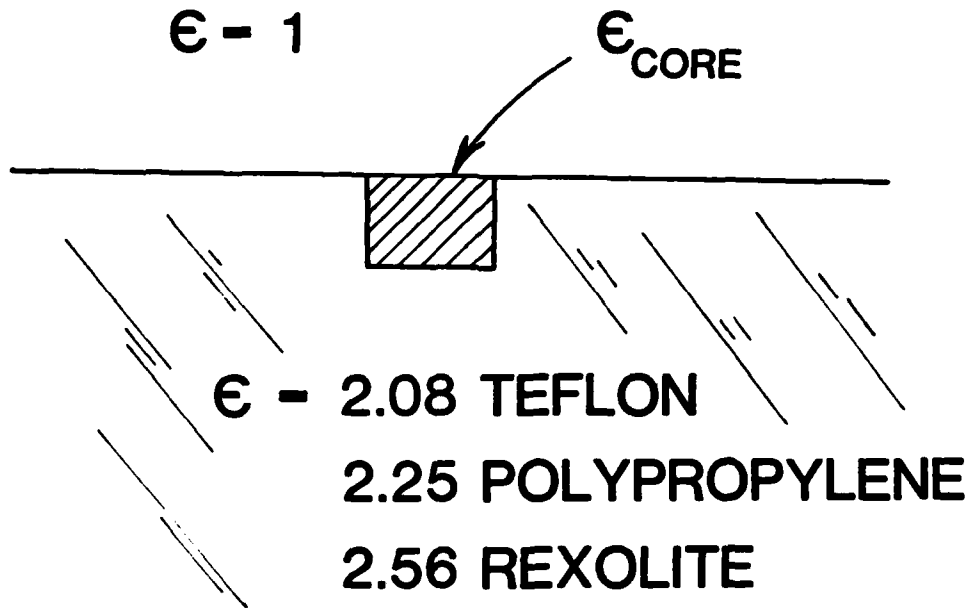

Figure IV-1: Cross-section of dielectric channel waveguide

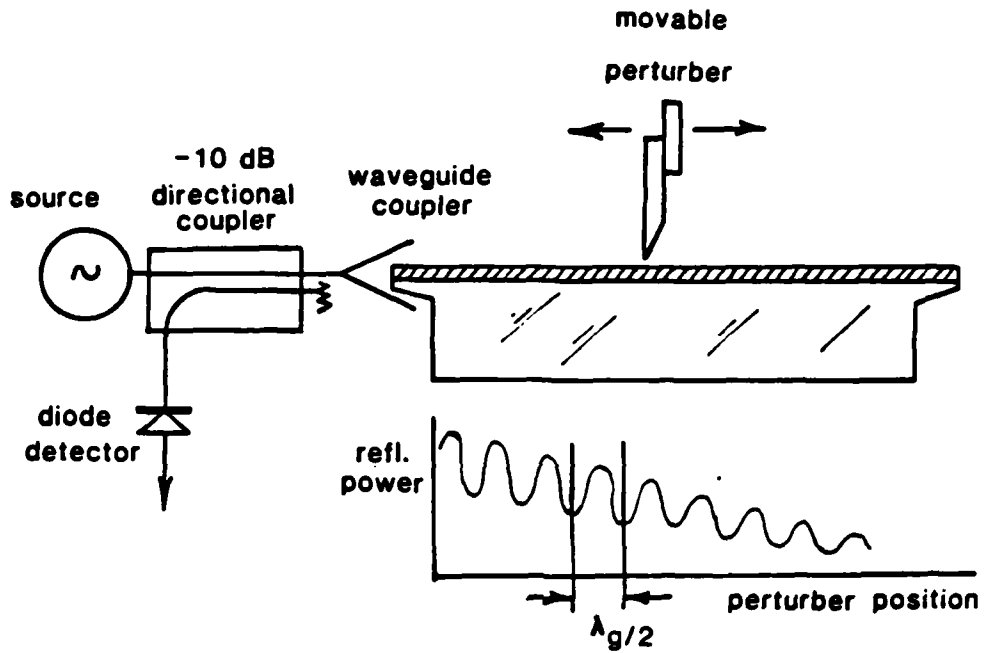

Figure IV-2: Set-up for measuring guide wavelength of a dielectric channel waveguide

amplitude of this interference changes as the relative phase between these two signals changes. Thus, as the perturber was moved along the length of the channel, a sequence of maxima and minima in reflected power was sensed with a -10dB directional coupler and a Schottky diode. The guide wavelength is twice the distance the perturber is moved between successive minima.

The guide wavelengths for various combinations of guide dimensions and dielectric powders were compared to the values predicted by Marcatili's approximate theory [Ref. IV-1] for the fundamental vertically polarized mode. In order to use Marcatili's theory, the dielectric constants of the powders were needed. The density of the powder in the channel was determined by weight measurement, and previously measured curves of dielectric constant versus density were used to find the effective dielectric constant of the powder packed into the channel. The dielectric constants of the powders were measured at 10 Ghz using the shorted-waveguide technique. These measurements were made at 10 Ghz because of the difficulty of controlling the length of a powder sample sufficiently accurately to measure its dielectric constant at 94 Ghz. For low-loss dielectrics we do not expect much change in dielectric constant between 10 and 94 Ghz.

A comparison of the measured values of the guide wavelength with those predicted for the $E_{y_{11}}$ mode by Marcatili's approximate theory is given in Table IV-1 for various powders in a teflon substrate at 94 Ghz. The uncertainty in the guide wavelength predicted by Marcatili's theory is estimated from the uncertainty in the dielectric constant of the powder.

TABLE IV-1

Comparison of measured quick wavelength of channel guide with that predicted for the $E_{y_{11}}$ mode by Marcatali's theory

Type of Powder	Width of channel (mm)	Depth of channel (mm)	Powder Density (g/cm ³)	Dielectric Constant	λ_g (meas.) (mm)	λ_g (Marcatali) (mm)
1	1.14	1.22	1.69 ± .05	4.43 ± .25	1.86	2.00 ± .07
1	0.94	0.94	1.95 ± .07	5.78 ± .35	1.86	1.96 ± .08
2	1.12	1.12	1.77 ± .04	5.0 ± .4	2.06	1.9 ± .1

Powder 1 is nickel-aluminum-titanate (Trans-Tech D-30).
Powder 2 is barium tetra-titanate (Trans-Tech D-38).

Other powders, substrates, and channel dimensions were evaluated after the end of the contract period. Some of these results were reported at the IEEE MTT-S International Symposium [Ref. IV-2] as Appendix A. In addition, a 3 dB directional coupler was designed according to Marcatili's theory and successfully fabricated. Future work will include resonators and filters using this channel waveguide medium.

REFERENCES

- IV-1 E.A.J. Marcatili, "Dielectric Rectangular Waveguide and Directional Coupler for Integrated Optics", Bell Syst. Tech. J. Vol. 48, pp. 2071-2102, Sep. 1969.
- IV-2 W.M. Bruno and W.B. Bridges, "Powder Core Dielectric Waveguides", 1984 IEEE MTT-S INTERNATIONAL MICROWAVE SYMPOSIUM DIGEST, pp. 497-498.

POWDER CORE DIELECTRIC WAVEGUIDES

William M. Bruno and William B. Bridges

California Institute of Technology
Pasadena, California

A powder-filled groove in the surface of a teflon substrate has been demonstrated as a dielectric waveguide at 94 Ghz. Guide wavelengths measured for combinations of guide dimensions and powders agree within 10% of values predicted by Marcatili's approximate theory. Attenuation constants of 0.2 to 0.3 dB/cm were measured for barium tetra-titanate.

A powder-filled groove in the surface of a teflon substrate has been demonstrated as a dielectric waveguide at 94 Ghz. This guide appears to be an attractive medium for low-cost, complex mm-wave components and integrated circuits. We have also demonstrated flexible dielectric waveguides by filling hollow low dielectric constant polymer tubes with low loss, high dielectric constant powders. This technique was used successfully at 10 Ghz and at 94 Ghz. However, the groove guide was used for guide wavelength and attenuation measurements since it proved easier to pack uniformly than the thin tubes used at 94 Ghz (18, 19, 20, 21 AWG teflon spaghetti). In addition, the cross-sectional dimensions of standard teflon spaghetti vary too much with length to give accurate measurements.

A rectangular groove was milled into the surface of a low-loss (TFE teflon) substrate and was filled with a high dielectric constant powder to form the core of a dielectric waveguide (Fig. 1). With this configuration, the powder could be packed from the top to assure a sufficiently uniform density along the length of the groove. Rectangular grooves with cross-sectional dimensions varying less than 0.002 inches from the specified values could be milled with relative ease. This degree of dimensional accuracy was found to be sufficient at 94 Ghz to produce a guide wavelength uniform within our measurement accuracy.

The guide wavelength and loss per unit length were measured for the fundamental vertically polarized mode of various powder-filled rectangular groove waveguides using the set-up shown in Fig. 1. On each end of the substrate the dielectric-filled groove was extended with a thin-walled trough of substrate material. This trough fitted snugly into the end of a slightly flared section of metal waveguide to couple to the dielectric guide. Lossy inserts made from

Emerson and Cumming MF-110 absorber were placed at non-periodic intervals in the teflon substrate 3 mm from the groove to attenuate any substrate modes that might have been excited at the coupling point.

To measure the guide wavelength, a metal perturber was held mechanically just above the surface of the powder. This perturber reflects a small fraction of the powder travelling along the waveguide toward the feed, where it interferes with the reflection from the input coupler. The amplitude of this interference changes as the relative phase between these two signals changes. Thus, as the perturber was moved along the length of the groove, a sequence of maxima and minima in reflected power was sensed with a -10dB directional coupler and a Schottky diode. The guide wavelength is twice the distance the perturber is moved between successive minima.

The guide wavelengths for various combinations of guide dimensions and dielectric powders were compared to the values predicted by Marcatili's approximate theory (1) for the fundamental vertically polarized mode. In order to use Marcatili's theory, the dielectric constants of the powders were needed. The density of the powder in the groove was determined by weight measurement, and previously measured curves of dielectric constant versus density were used to find the effective dielectric constant of the powder packed into the groove. The dielectric constants of the powders were measured at 10 Ghz using the shorted-waveguide technique. These measurements were made at 10 Ghz because of the difficulty of controlling the length of a powder sample sufficiently accurately to measure its dielectric constant at 94 Ghz. For low-loss dielectrics we do not expect much change in dielectric constant between 10 and 94 Ghz.

To determine the loss-per-unit length of a groove waveguide, the power transmitted from end to-end was measured by a detector connected to the flared section of metal waveguide surrounding the trough on the far end of the substrate (Fig. 1). E/H tuners were used to match the coupling sections. The power detected at the far end could not be significantly increased by adjusting the E/H tuners, so we assume that the couplers are well matched. In addition, removing the lossy substrate inserts did not affect the power received at the far end, indicating that little

power is lost to substrate modes. A third detector connected to a small horn antenna was used as a movable probe to determine that an insignificant amount of power was radiated from the couplers or guide. Finally, the power reflected from the feed coupling was -20dB down from the incident power. Taken together, these observations indicate that almost all of the incident power was coupled into the dielectric waveguide, so that the difference between the incident power and the power detected at the far end represents dielectric waveguide loss. The loss per unit length is then this loss divided by the length of the dielectric waveguide.

A second method for measuring loss-per-unit length along the powder-filled groove was used as a rough check. A detector with a short section of metal waveguide attached and positioned just above the groove was used as a probe. The probe-to-groove spacing had to be maintained accurately as the probe was moved along the groove. The slope of the detected power (dB) versus distance along the groove also gives the loss-per-unit length in dB/m.

A comparison between the measured values of the guide wavelength with those predicted for the E₁₁ mode by Marcatili's approximate theory is given below for various powders in a teflon substrate at 94 Ghz.

Type of Powder	Width of groove (mm)	Depth of groove (mm)	Powder Density (g/cm ³)	Dielectric Constant	λ_g (meas.) (mm)	λ_g (Marcatili) (mm)
1	1.14	1.22	1.69 ± 0.05	4.43 ± 0.25	1.86	2.00 ± 0.07
1	0.94	0.94	1.95 ± 0.07	5.70 ± 0.35	1.86	1.96 ± 0.08
2	1.12	1.12	1.77 ± 0.04	5.0 ± 0.4	2.86	1.9 ± 0.1
3	1.14	1.12	1.82 ± 0.03	4.60 ± 0.12	2.18	1.90 ± 0.04
3	1.04	1.04	1.95 ± 0.03	5.20 ± 0.15	2.12	1.93 ± 0.04

Powder 1 is nickel-aluminum-titanate (Trans-Tech D-30).

Powder 2 is barium tetra-titanate (Trans-Tech D-3B).

Powder 3 is barium tetra-titanate (Trans-Tech D-0512).

The uncertainty in the guide wavelength predicted by Marcatili's theory is estimated from the uncertainty in the dielectric constant of the powder.

The results of measurements of the loss per unit length along a straight powder-filled groove in a teflon substrate are given below.

Type of Powder	Width of groove (mm)	Depth of groove (mm)	Density of Powder (g/cm ³)	Technique	Loss (dB/cm)
1	1.14	1.22	1.44	movable detector	6.57 ± 0.08
1	1.14	1.22	1.44	end-to-end transmission	6.48
1	1.14	1.12	1.44	end-to-end transmission	6.43
3	1.14	1.12	1.82	end-to-end transmission	6.21
3	1.04	1.04	1.95	end-to-end transmission	6.27

Additional measurements are in progress and will be reported at the meeting.

- (1) E.A.J. Marcatili, "Dielectric Rectangular Waveguide and Directional Coupler for Integrated Optics," Bell Syst. Tech. J. Vol. 48, pp. 2071-2102: Sept. 1969.

This work was supported by the Office of Naval Research under contract N00014-79-C-0839.

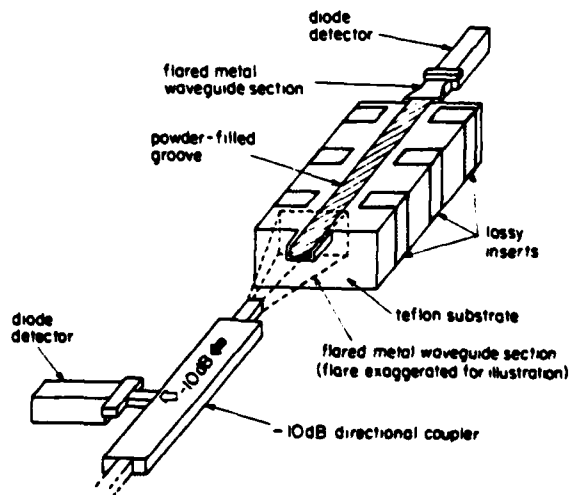

DISTRIBUTION LIST - TECHNICAL REPORTS

Contract N00014-79-C-0839

Office of Naval Research Code 414 Arlington, VA 22217	4	Dr. H. C. Nathanson Westinghouse Research and Development Center Beulah Road Pittsburgh, PA 15235	1
Naval Research Laboratory 4555 Overlook Avenue, S.W. Washington, D.C. 20375 Attn: Code 6811 6850	1 1	Dr. Daniel Chen Rockwell International Science Center P.O. Box 1085 Thousand Oaks, CA 91360	1
Defense Logistics Agency Defense Documentation Center Bldg. 5, Cameron Station Alexandria, VA 22314	12	Dr. D. Krum Hughes Research Laboratory 3011 Malibu Canyon Road Malibu, CA 90265	
Dr. Y. S. Park AFWAL/DHR Building 450 Wright-Patterson AFB Ohio 45433	1	Mr. Lothar Wandinger ECOM/AMSEL/TL/IJ Forth Monmouth, NJ 07003	1
ERADCOM DELET-M Fort Monmouth, NJ 07703	1	Dr. William Lindley MIT Lincoln Laboratory F124 A, P.O. Box 73 Lexington, MA 02173	1
Texas Instruments, Inc. Central Research Lab. M.S. 134, P.O. Box 225936 13500 North Central Expressway Dallas, TX 75265 Attn: Dr. Wisseman	1	Commander U.S. Army Electronics Command V. Gelnovatch (DRSEL-TL-IC) Fort Monmouth, NJ 07703	1
Dr. R. M. Malbon/M.S. IC Avantek, Inc. 3175 Bowers Avenue Santa Clara, CA 94304	1	RCA Microwave Technology Center Dr. F. Sterzer Princeton, NJ 08540	1
M. R. Bierig Raytheon Company 28 Seyon Street Waltham, MA 02154	1	Watkins-Johnson Company E.J. Crescenzi, Jr./K. Niclas 3333 Hillview Avenue Stanford Industrial Park Palo Alto, CA 94304	1
Dr. R. Bell, K-101 Varian Associates, Inc. 611 Hansen Way Palo Alto, CA 94304	1		
Hewlett-Packard Corp. Dr. Robert Archer 1501 Page Mill Road Palo Alto, CA 94306	1		

Distribution List - Technical Reports (continued)

Commandant Marine Corps Scientific Advisor (Code AX) Washington, D.C. 20380	1	AIL TECH 612 N. Mary Avenue Sunnyvale, CA 94086 Attn: G. D. Vendelin	1
Communications Transistor Corporation Dr. W. Weisenberger 301 Industrial Way San Carlos, CA 94070	1	Professors Hauser and Littlejohn Department of Electrical Engineering North Carolina State Univ. Raleigh, NC 27607	1
Microwave Associates Northwest Industrial Park Drs. F. A. Brand/J. Saloom Burlington, MA 01803	1	Professor J. Beyer University of Wisconsin- Madison 750 University Avenue Madison, Wisconsin 53706	1
Commander, AFAL AFWAL/AADM Dr. Don Rees Wright-Patterson AFB Ohio 45433	1	General Electric Company Attn: W. Perkins Electronics Lab 3-115/B4 P.O. Box 4840 Syracuse, NY 13221	1
Professor Walter Ku Phillips Hall Cornell University Ithaca, NY 14853	1	Mr. John Carson Code 5532 Naval Ocean Systems Center San Diego, CA 92152	1
Commander Harry Diamond Laboratories Mr. Horst W. A. Gerlach 2800 Powder Mill Road Adelphia, MD 20783	1	Dr. Hans Steyskal RADC/EEA Hanscom AFB, MA 01731	1
Advisory Group on Electron Devices 201 Varick Street 9th Floor New York, NY 10014	1	Dr. Richard Brandt ONR WEST 1030 E. Green Street Pasadena, CA 91106	2
D. Claxton MS/1414 One Space Park Redondo Beach, CA 90278	1	Professor Donald M. Bolle Dept. of Electrical and Computer Engineering Lehigh University Bethlehem, PA 18015	1
Professor L. Eastman Phillips Hall Cornell University Ithaca, NY 14853	1		

END

FILMED

12-84

DTIC