

AD-A148 101

CATALYTIC IGNITION AND COMBUSTION OF LEAN MIXTURES(U)  
NORTHWESTERN UNIV EVANSTON IL DEPT OF MECHANICAL  
ENGINEERING C K LAW 1984 N00014-80-C-0586

1/2

UNCLASSIFIED

F/G 7/1

NL

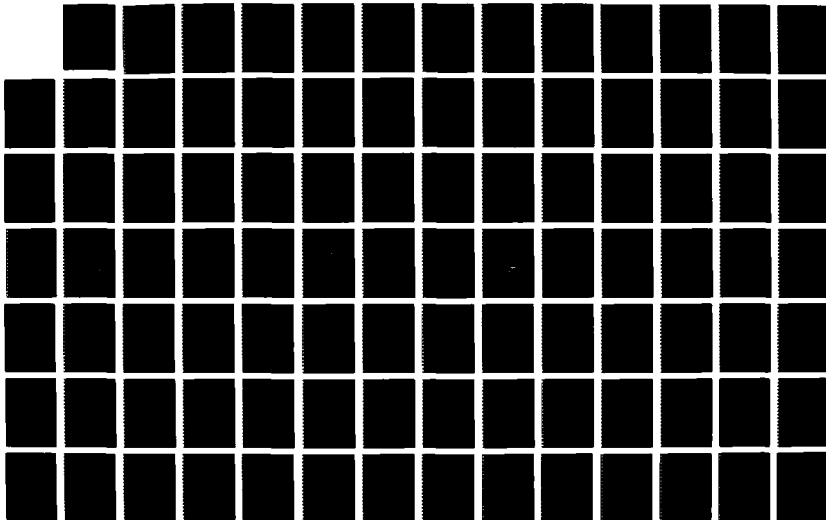

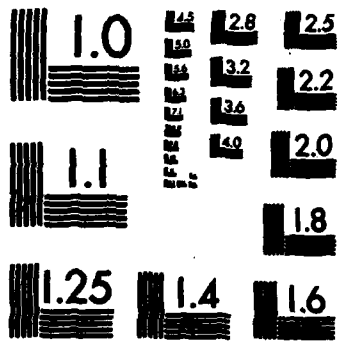

MICROCOPY RESOLUTION TEST CHART  
NATIONAL BUREAU OF STANDARDS-1963-A

**RECEIVED**  
**JUN 5 1984**  
**IN ONR, CODE 432**

FINAL REPORT

**CATALYTIC IGNITION AND  
COMBUSTION OF LEAN MIXTURES**

**AD-A148 101**

REPRODUCED BY  
**NATIONAL TECHNICAL  
INFORMATION SERVICE**  
U.S. DEPARTMENT OF COMMERCE  
SPRINGFIELD, VA. 22161

This document has been approved  
for public release and sale; its  
distribution is unlimited.

**84 11 16 070**

FINAL REPORT

CATALYTIC IGNITION AND COMBUSTION  
OF LEAN MIXTURES

Work Sponsored by

The Office of Naval Research  
Under Contract No. N00014-80-C-0586  
(M. K. Ellingsworth - Technical Monitor)

Report Prepared by

C. K. Law, Principal Investigator  
Department of Mechanical Engineering  
Northwestern University  
Evanston, Illinois 60201

This document has been approved  
for public release and sale; its  
distribution is unlimited.

## ABSTRACT

Ignition and heat release rates of fuel/oxygen/nitrogen over platinum wires are experimentally studied using micro-calorimetry, aiming to gain additional understanding on the complex transport and kinetic processes involved during catalytic oxidation so as to relate the macroscopic observables with the microscopic behavior. The fuels studied are propane, butane, propylene, ethylene, carbon monoxide and hydrogen. Parameters investigated include catalyst surface temperature, fuel and oxygen concentrations, and flow velocity.

Results show that for very low Reynolds number flows the flow velocity has negligible influence on the ignition temperature. Its influence on the heat release rates is also negligible but only for the reactions in kinetically controlled regime. Variation of fuel concentration is found to be an important factor in that the ignition temperatures of propane and butane decrease as their concentrations are increased from lean to rich mixtures while the opposite trend is observed for propylene, ethylene, carbon monoxide and hydrogen. The effect of oxygen concentration on the ignition temperature of propane display a minimum on the lean side of stoichiometry whereas for carbon monoxide the ignition becomes progressively easier as the oxygen concentration is increased. The heat release rate shows that the highly-reactive hydrogen/air mixture is usually diffusion-limited but, propane/air is not limited by mass transport rate. Other fuel/air mixtures show both trends - kinetically controlled at low temperature range but diffusion limited at higher temperatures. Based on the above

results a qualitative correlation is made between the ignition temperature and the chemisorption strength of the fuel molecules relative to oxygen.



Accession For	
NTIS GPO&I	
DTIC TAB	
Unannounced	
Justification	
<i>File on file</i>	
Distribution/	
Availability Codes	
Dist	Avail and/or Special
A-1	

## TABLE OF CONTENTS

	Page
ABSTRACT.....	ii
TABLE OF CONTENTS.....	vi
LIST OF FIGURES.....	ix
1. INTRODUCTION.....	1
1.1 ORIENTATION.....	1
1.1.1 Motivation for the Work.....	2
1.1.2 Direction of the Work.....	4
1.2 OVERVIEW OF THE REPORT.....	5
2. BACKGROUND MATERIAL.....	6
2.1 FUNDAMENTALS OF CHEMICAL KINETICS.....	6
2.1.1 Reaction Rates.....	6
2.1.2 Heterogeneous Catalysis.....	9
2.1.3 Reaction Limits.....	15
2.1.4 Adsorption Strength.....	18
2.2 FROM MICROSCOPIC TO MACROSCOPIC LEVEL.....	19
3. EXPERIMENTAL CONSIDERATIONS.....	22
3.1 METHODOLOGY.....	22
3.1.1 The Development of Micro-Calorimetry.....	23
3.1.2 Basis of Heated-Wire Technique.....	25
3.1.3 Flow Field Around the Catalyst.....	29
3.2 EXPERIMENTAL FACILITIES.....	33
3.2.1 Flow System.....	33
3.2.2 Electronic System.....	37
3.2.3 Data Acquisition System.....	43
3.2.4 Catalyst System.....	45

Pages iv and v are blank

---

3.3	EXPERIMENTAL PROCEDURES.....	49
3.3.1	Parameters.....	50
3.3.2	Procedures.....	53
4.	IGNITION TEMPERATURE.....	54
4.1	DEFINITION.....	54
4.1.1	Theory of Ignition.....	54
4.1.2	Catalytic Surface Ignition.....	55
4.2	FACTORS GOVERNING CATALYTIC IGNITION.....	56
4.2.1	Thermal Ignition Analysis.....	56
4.2.2	Limitations of the Analysis.....	58
4.2.3	Classification by Chemisorption Strength.....	61
4.3	IGNITION OF THE PROPANE GROUP.....	66
4.3.1	Effect of Fuel Concentration.....	67
4.3.2	The Propane/Oxygen/Nitrogen Mixtures.....	73
4.3.3	Effect of Oxygen Concentration.....	79
4.4	IGNITION OF THE PROPYLENE GROUP.....	81
4.4.1	Effect of Fuel Concentration.....	81
4.4.2	Comparison Between Propylene/Air and Ethylene/Air Mixtures.....	88
4.4.3	The Fuel/Oxygen/Nitrogen Mixtures.....	90
4.4.4	Effect of Oxygen Concentrations.....	90
4.5	SECONDARY EFFECTS.....	94
4.5.1	Effect of Velocity.....	94
4.5.2	Effect of Pre-treatment of the Catalyst.....	95
4.6	SUMMARY.....	100
5.	HEAT RELEASE RATE.....	102
5.1	GENERAL OBSERVATIONS.....	102
5.1.1	Theory.....	102
5.1.2	Literature Survey.....	106
5.1.3	Scope of Present Work.....	107
5.2	EFFECT OF FUEL AND OXYGEN CONCENTRATIONS.....	108
5.2.1	Fuel/Air Mixtures.....	108
5.2.2	Fuel/Oxygen/Nitrogen Mixtures.....	114
5.3	EFFECT OF FLOW VELOCITY AND AGING.....	115
5.4	SUMMARY.....	136

6. CONCLUSIONS AND RECOMMENDATIONS.....	138
REFERENCES.....	141
PUBLICATIONS.....	148

## LIST OF ILLUSTRATIONS

Figure		Page
2.1	Potential-energy profile for an exothermic reaction, showing the lower activation energy of the catalyzed reaction.....	10
2.2	Comparison of Arrhenius plot for catalyzed and uncatalyzed reactions.....	11
2.3	Sequence of five elementary steps that are fundamental to all heterogeneous catalytic reactions: (a) Langmuir - Hinshelwood Mechanism; (b) Eley - Rideal Mechanism.....	12
2.4	Potential energy curves for the physical and chemical adsorption.....	14
2.5	Arrhenius plot indicating the transition of the reaction from kinetically controlled to mass transport limited regime.....	17
2.6	Arrhenius plot for the catalytic surface reaction in which the surface coverage by reactants falls below its maximum value.....	17
3.1	Pictorial representation of the heated-wire calorimetric technique: (a) Electrical power requirement for the catalyst in reacting (broken line) and non-reacting (solid line) environment; (b) the heat release rate obtained from (a).....	27
3.2	Summary of the catalyst configuration: (a) calorimetric bead; (b) simple wire coiled in helix; (c) catalytic film deposited on quartz substrate.....	30
3.3	Flow field around the catalysts: (a) evolutionary processes; (b) steady state processes.....	31
3.4	Schematic diagram of the flow system.....	34
3.5	Section diagram of the test chamber.....	35
3.6	Section diagram of the mixing chamber.....	38
3.7	Schematic diagram of the functional elements of the electronic system.....	40
3.8	Generalized input-output configuration of the control system...	41

3.9	Measurement of the resistance of the catalyst at a reference temperature.....	44
3.10	Schematic diagram of the data acquisition system.....	46
3.11	Strip chart output of the changes in the power consumption....	47
3.12	Catalyst support system.....	48
3.13	The range of propane/oxygen/nitrogen mixtures that can be safely investigated.....	52
4.1	Schematic presentation of heat generation due to chemical reaction and heat loss to the surrounding at different catalyst temperatures.....	59
4.2	Correlation of the catalytic activity with the heat of adsorption.....	63
4.3	Effect of fuel concentration on the ignition temperature of propane/air mixtures.....	68
4.4	Effect of fuel concentration on the ignition temperature of butane/air mixtures.....	69
4.5	Effect of fuel concentration on the ignition temperature of propane/air and butane/air mixtures: A comparison based on the equivalence ratio.....	70
4.6	Electrical power input to the catalytic wire for propane/air mixture with 2% propane by volume.....	71
4.7	Electrical power input to the catalytic wire for propane/air mixture with 0.5% propane by volume.....	72
4.8	Concentration map of propane/oxygen/nitrogen mixtures.....	75
4.9	Ignition temperatures of propane/oxygen/nitrogen mixtures at constant oxygen concentrations.....	76
4.10	Ignition temperature of propane/oxygen/nitrogen mixtures at constant equivalence ratios.....	77
4.11	Ignition temperature of propane/oxygen/nitrogen mixtures at constant oxygen concentrations: Plot based on the equivalence ratio.....	78
4.12	Ignition temperature of propane/oxygen/nitrogen mixtures at constant fuel concentration.....	80

4.13	Effect of fuel concentration on the ignition temperature of propylene/air mixtures.....	82
4.14	Effect of fuel concentration on the ignition temperature of ethylene/air mixtures.....	83
4.15	Effect of fuel concentration on the ignition temperature of carbon monoxide/air mixtures.....	84
4.16	Effect of fuel concentration on the ignition temperature of hydrogen/air mixtures.....	85
4.17	Effect of fuel concentration on the ignition temperature of propylene/air and ethylene/air mixtures: A comparison based on the equivalence ratio.....	89
4.18	Concentration map of carbon monoxide/oxygen/nitrogen mixtures.....	91
4.19	Ignition temperature of carbon monoxide/oxygen/nitrogen mixtures at constant oxygen concentrations.....	92
4.20	Ignition temperature of carbon monoxide/oxygen/nitrogen mixtures at constant carbon monoxide concentration.....	93
4.21	Effect of flow velocity on the ignition temperature: (a) propane/air mixtures; (b) hydrogen/air mixtures.....	96
4.22	Effect of aging on the ignition temperature: propane/air.....	98
4.23	Effect of aging on the ignition temperature: hydrogen/air.....	99
5.1	Effect of fuel concentration on the heat release rate of propane/air mixtures.....	109
5.2	Effect of fuel concentration on the heat release rate of butane/air mixtures.....	110
5.3	Effect of fuel concentration on the heat release rate of propylene/air mixtures.....	111
5.4	Effect of fuel concentration on the heat release rate of carbon monoxide/air mixtures.....	112
5.5	Effect of fuel concentration on the heat release rate of hydrogen/air mixtures.....	113
5.6	Heat release rate of propane/oxygen/nitrogen mixtures at constant oxygen concentrations: (a) 10% O <sub>2</sub> ; (b) 7.5% O <sub>2</sub> ; (c) 4% O <sub>2</sub> , C <sub>3</sub> H <sub>8</sub> < 1.15; (d) 4% O <sub>2</sub> , C <sub>3</sub> H <sub>8</sub> > 1.5.....	116

5.7	Heat release rate of carbon monoxide/oxygen/nitrogen mixtures at constant oxygen concentrations: (a) 10% O <sub>2</sub> ; (b) 6% O <sub>2</sub> ; (c) 4% O <sub>2</sub> ; (d) 3% O <sub>2</sub> .....	120
5.8	Heat release rate of propane/oxygen/nitrogen mixtures at constant propane concentrations: (a) 0.5% C <sub>3</sub> H <sub>8</sub> ; (b) 1.0% C <sub>3</sub> H <sub>8</sub> ; (c) 1.5% C <sub>3</sub> H <sub>8</sub> .....	124
5.9	Heat release rate of carbon monoxide/oxygen/nitrogen mixtures at constant carbon monoxide concentrations: (a) 0.5% CO; (b) 1.0% CO; (c) 2.0% CO.....	127
5.10	Effect of velocity on the heat release rates: (a) propane/air mixture with 1.0% C <sub>3</sub> H <sub>8</sub> ; (b) propane/air mixture with 2.0% C <sub>3</sub> H <sub>8</sub> ; (c) hydrogen/air mixture with 2.5% H <sub>2</sub> .....	131
5.11	Effect of aging on the heat release rates: (a) propane/air mixtures; (b) hydrogen/air mixtures.....	134

## CHAPTER I

### INTRODUCTION

#### 1.1 ORIENTATION

A relatively new field, catalytic combustion emerged from the union of catalysis and combustion, each of which is already a very broad discipline by itself. Catalysis alone involves research endeavors from sub-atomic level of solid-state physics to the molecular level in organic and surface chemistry, encompassing seemingly unrelated fields such as chemical kinetics and physical metallurgy. All these manifold approaches are aimed to explaining a single phenomenon that characterizes catalysis - a process in which the rate of chemical reaction is altered by addition of some substance which itself undergoes no permanent chemical change.

Combustion, on the other hand, cannot be defined as one single phenomenon and, as such, embraces diverse research community. Problems in ignition, extinction, flame structure, solid propellants, sprays, pollutant formation, and internal combustion engines are but a few examples to which the combustion research is addressed.

Therefore, catalytic combustion, like a huge elephant in the famed fable by Aesop, is an extensive field of study which no one research effort can claim to understand the whole. Only when numerous contributions from widely different but related disciplines are combined is the understanding of this extremely complicated field possible. This present work is one such contribution towards forming a complete picture by providing the results from new findings, together with insights to

explain the observed behavior at the fundamental level. This chapter is devoted to providing the readers with an orientation so that the material presented in this thesis can be better understood in proper perspective.

### 1.1.1 Motivation for the Work

Much of the world's energy needs for generating power and heat are derived from the burning of fossil fuels. Over the years through compromises in the technical requirements of combustion chamber performances, material compatibility, fuel handling, availability and cost have resulted in somewhat rigid specification for fuels which can burn reliably and efficiently. Apart from some restricted cases involving the surface burning of char, most of these hydrocarbon oxidative reactions take place with both reactants in the gas phase. A unique property which characterizes the gas-phase hydrocarbon oxidative reactions of interest to combustion is the effective large activation energy and, consequently, high temperature needed for reaction to initiate. Hence, ignition is a major concern associated with the design and the operation of heat and power engines.

In addition, the rapid depletion of the global petroleum reserve has made synthetic liquid fuels derived from coal, tar sand, oil shale, biomass and other non-conventional sources more attractive. These alternate fuels, however, cannot easily meet the existing specifications without extensive chemical reprocessing. For example, coal-derived syngases have higher viscosities, boiling point ranges and aromatic

contents. The first two factors directly influence the atomization and vaporization characteristics of liquid fuels, whereas the increased aromatic content will significantly increase the extent of soot formation. These difficulties are further aggravated when the raw power of combustion must be tamed to meet the newly awakened conscience for environment (Dwyer, 1972). Air pollution, which has a decisively negative impact on weather formation and human health, has emerged as one of the major considerations in using combustion system alongside the efficiency and the power output.

In view of the above considerations, it is inevitable that combustors would have to be modified to lessen their dependence on fuel specifications. The ultimate goal is to be able to use non-specification, low-quality fuels with minimum pollutant emissions but without sacrificing efficiency. To this end, incorporating catalysts into the existing combustion system has been recognized as a practical approach. A substantial benefit, either actual or potential, of using catalysts in gas turbines, flame holders and heat exchangers have already been demonstrated (Rosfjord, 1976). However, full scale, wide-spread application of catalytic combustion system is impeded by lack of clear understanding of physico-chemical processes involved in catalytic reactions. It is now quite obvious that systematic investigation into the nature of heterogeneous catalytic oxidation behavior holds a paramount interest, if not urgent importance, to ensure a continued progress in the field of catalytic combustion.

### 1.1.2 Direction of the Work

The research effort on catalytic combustion has been basically three-pronged. The most effort has been expended in characterizing and measuring the effect of incorporating catalyst in actual combustors. Development of stable and rugged catalysts has followed in order to accommodate practical gas as well as liquid fuels in the exacting ambience as found in real gas turbines and aircraft after burners (Bracco and Curtis, 1981). However, much needed research to gain fundamental understanding of physico-chemical phenomena is carried out to a much less extent. In view of the fact that the interest in the use of catalyst to combustion was initiated with a goal of reducing thermal  $\text{NO}_x$  from gas turbines and that the existing knowledge was totally inadequate to describe the phenomena, it is understandable why the time consuming process of building a solid foundation took a back seat to the development and performance characterization of practical catalytic combustors. The urgency to control pollution and to improve combustion efficiency still exists, but there is limit to the advancement through trial-and-error approach.

Therefore, the goal of the work described in this report is to understand the nature of heterogeneous catalytic oxidation of various fuels by identifying the dominant factors that dictate the surface reactivity. Specifically, the fuel tested are propane, butane, hydrogen, carbon monoxide, ethylene and propylene. The catalyst is platinum wire, both straight and coiled in helix. The directly measured quantities are the critical ignition temperature and the chemical heat

release rates, using a modified micro-calorimetric system. Effect of fuel and oxygen concentrations are the major variables. Effects of flow velocity and aging are also studied.

## 1.2 OVERVIEW OF THE REPORT

The main objective of the report is in connecting the macroscopically observable behaviors - specifically, the ignition temperature and chemical heat release - to the vast reserve of knowledge already compiled by researchers in catalysis. Therefore, a concise summary on the phenomena of heterogeneous catalysis is given in Chapter 2. Attention is given only to the material strictly relevant to combustion behavior.

The thrust of the report is in experimental investigations. An original experimental facility is designed and constructed specifically for this study. Therefore, a detailed description of the experimental methodology and the setup is presented in Chapter 3. Experimental procedures and verification processes are also included. Chapter 4 deals with the ignition behavior. Previous interpretations of ignition temperature are discussed in the beginning and a revised interpretation is presented in light of the experimental data obtained from this work. Relevant literature survey is presented where appropriate. Heat release rates are discussed in Chapter 5 closely following the format of the previous chapter on ignition temperature. The final chapter summarizes major points concluded from this work and makes recommendation for future works.

## CHAPTER 2

### BACKGROUND MATERIAL

#### 2.1 FUNDAMENTALS OF CHEMICAL KINETICS

The highly interdisciplinary nature of catalytic combustion has already been pointed out. The research direction can be largely divided into two, either physically or chemically oriented. The physical approach emphasizes the importance of geometric arrangement of the atoms involved and relates the catalytic activities to the electronic properties of the catalyst (Drauglis and Jaffee, 1975; Volkenstein, 1963). The chemical approach, on the other hand, regards the catalyst as an electron donor showing propensity to form a transitory bond with the reactants in the gas phase (Cullis, 1967; Kamball, 1971; Bond, 1974). In-depth discussion in terms of all the related fields would be unnecessarily lengthy. Therefore, only brief introductions to various phenomena are given in the following sections with two purposes in mind. The first object is to provide the reader with the minimum background material necessary to appreciate the essence of heterogeneous catalytic reactions. The second is to emphasize those factors that emerge as the dominant parameters in the special case of combustion reactions.

##### 2.1.1 Reaction Rates

If a reaction proceeds, how far and how fast will it go? These are the two questions that need to be answered to adequately describe a chemically reacting system. The first deals with the nature of the end

product of a process and can be answered from thermodynamic analysis by considering the energy level of initial and final states of the reacting system. The details of the intermediate steps taken to arrive at the final state become immaterial. The sense of time is also lost. Therefore, thermodynamic consideration alone is not sufficient to deal with the second question inquiring into the rate with which the end product is attained. The answer lies in the domain of chemical kinetics.

The rate of homogeneous reaction has been observed to vary with the concentrations of reactants raised to some power with the rate coefficient obeying the Arrhenius expression

$$k = A \exp(- E/RT)$$

where  $R$  is the universal gas constant and  $T$  is the absolute temperature.

Two theories have been developed to provide physical meaning to the above constants  $A$  and  $E$ . The collision theory essentially views the chemical reaction as a collision between reactants having enough energy between them to overcome an energy barrier placed in their path to the product state. Then the activation energy  $E$  means the minimum energy necessary to surmount the barrier and the whole exponential term is no other than the fraction of collisions having kinetic energy greater than  $E$ . The pre-exponential factor  $A$  becomes the number of collisions with proper orientation suitable for the reaction.

The statistical mechanics approach of the collision theory can be made more useful by introducing the concept of transition state. The

energetic intermediate species at the top of the energy barrier is sometimes called the activated complexes and can be considered to exist in equilibrium with the reactants. Then the reaction process can be described from the thermodynamic viewpoint since the inclusion of the transition state theory eventually relates the rate coefficient to Gibb's free energy of activation.

Although the above discussion is very brief, factors determining the reaction rate are immediately evident. The major factors are the concentrations of reactants which have direct bearing in the rate expression and the temperature which plays a critical role through the temperature-sensitive Arrhenius term. It is interesting to note that the two most influential factors are also the external variables that are easiest to manipulate if the only goal is to obtain a specific reaction rate. And, yet, in real life these are the two factors that constitute the uncompromising constraints. For example, in power engines, the problem of  $\text{NO}_x$  arises due to high combustion temperature. But lowering the reaction temperature through fuel-lean combustion has a practical limit and, therefore, is not considered to be a satisfactory solution by itself. Nor is increasing the temperature of the exhaust system desirable to eliminate the minute quantity of the unburned hydrocarbon fuel escaping into the atmosphere together with other combustion products. As in many other chemically reacting systems, the reactant concentrations and the temperature are irrevocably prescribed as the by-products in the process of achieving the main objective of the system, usually the power output.

The only other way to control the rate of reaction is by providing an alternate path for the reactants to proceed. This is precisely the power that defines catalyst and is widely utilized. That is, the catalyst makes its surface sites available to the reacting molecules such that the transition-state of molecule-catalyst complex is a low energy configuration providing an easier route for the reactants to follow in a subsequent reaction to form the final product. The energy hills of catalyzed and uncatalyzed reactions are illustrated in Fig. 2.1 which shows a schematic diagram of the potential energy profile for an exothermic reaction. The path for the catalyzed reaction is more complicated because the catalytic activity involves a sequence of individually identifiable events. However, the overall effect of the catalysis is to lower the energy hill which is a graphical representation of the activation energy. A smaller activation energy means that a given rate of reaction can be achieved at a lower temperature, as illustrated in Fig. 2.2 where the Arrhenius plots for catalyzed and uncatalyzed reactions are compared. Since it is the complicated reaction path that makes a catalyst useful, the details of the process involved in heterogeneous catalytic reactions will be discussed in the following section.

### 2.1.2 Heterogeneous Catalysis

A sequence of elementary steps is fundamental to all heterogeneous catalytic reactions (Thompson and Webb, 1968; Robertson, 1970; Satterfield, 1980) and is shown in Fig. 2.3. The first in the sequence

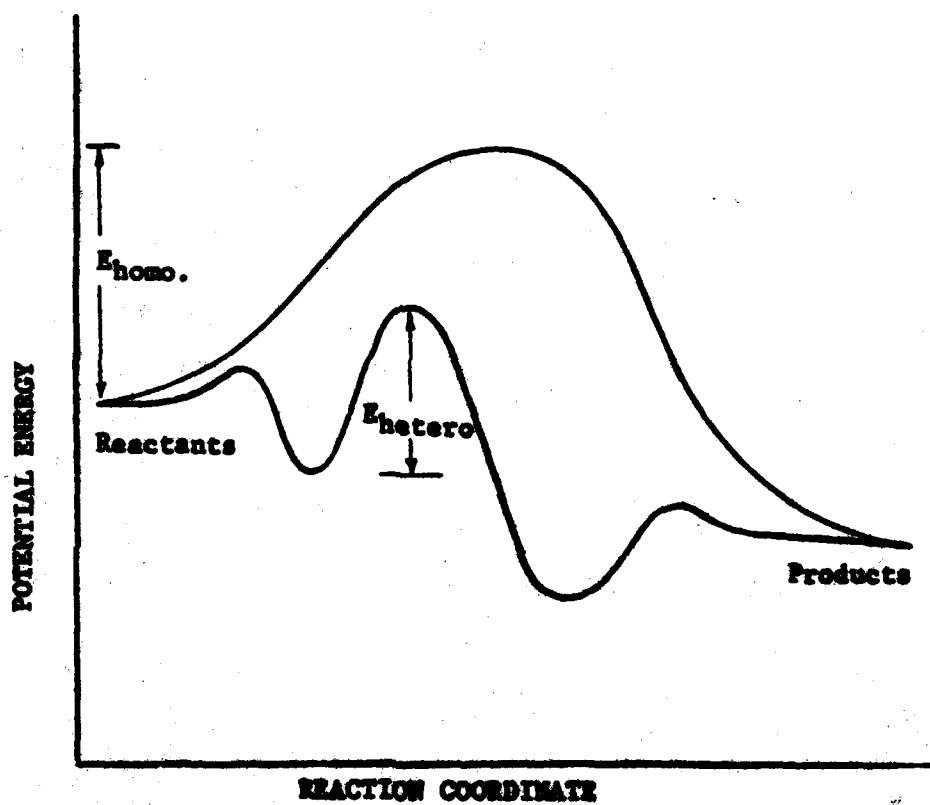

Figure 2.1 Potential-energy profile for an exothermic reaction, showing the lower activation energy of the catalyzed reaction

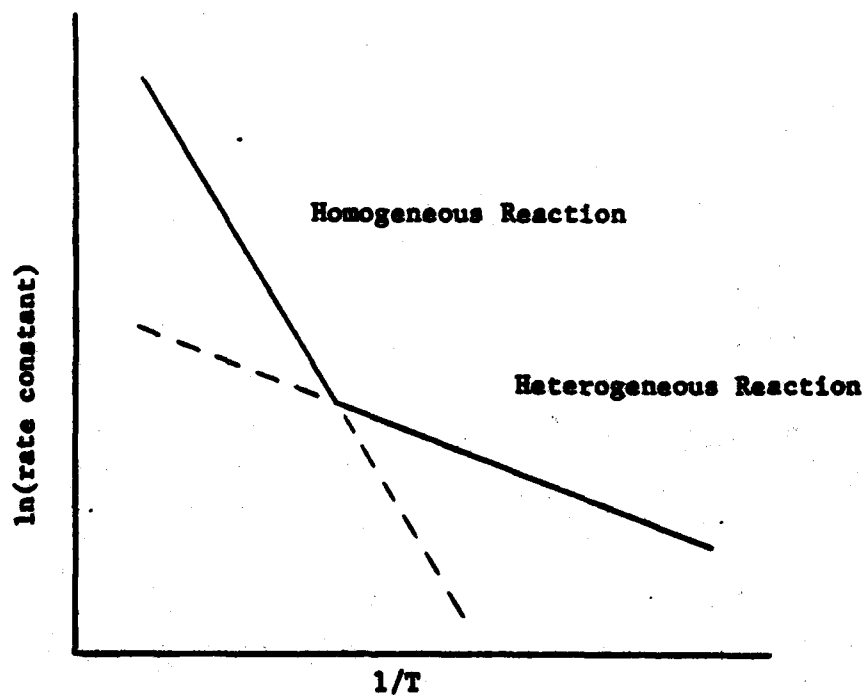

Figure 2.2 Comparison of Arrhenius plot for catalyzed and uncatalyzed reactions

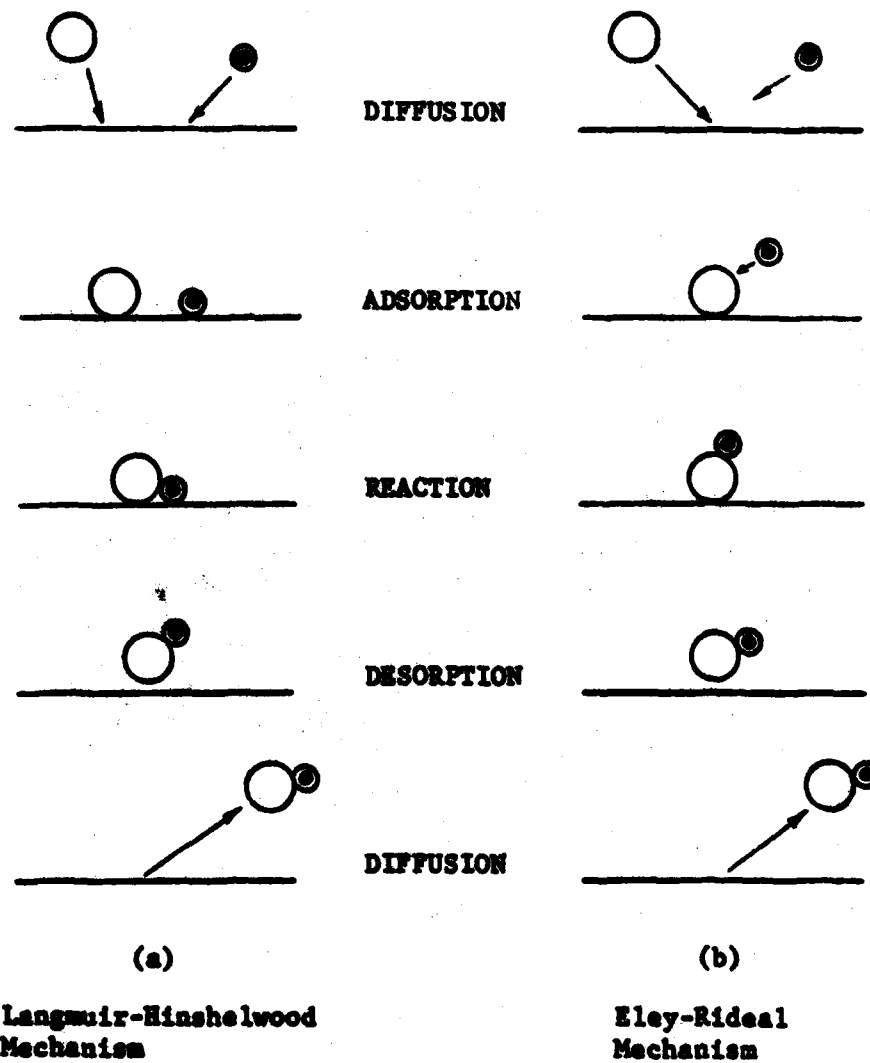

Figure 2.3 Sequence of five elementary steps that are fundamental to all heterogeneous catalytic reactions

is a diffusional process that brings the reactant to the catalytic surface. Subsequently, two types of interactions between the reactant and the surface, namely physical adsorption and chemisorption, are possible. Physical adsorption involves weak attractive forces without chemical alteration of the molecules. They are of the van der Waals type such as electrostatic or induced dipole moments and may be considered as a prelude to chemisorption which is exclusively responsible for catalytic behavior. The transition from physical to chemical adsorption for an arbitrary molecule is shown in Fig. 2.4 together with the potential energy curves illustrating the activated nature of chemisorption. That is, the chemisorption is a chemical process in which new molecular bonds are formed. For many molecules some changes in the old bonds are prerequisite to having a strong interaction with the surface sites. For example, hydrogen molecules are known to dissociate into individual atoms before chemisorption. Therefore, if a chemical reaction can be construed as a progressive transformation of reactants into product, then the chemisorbed molecules can be conceived as an activated intermediate resembling some aspects of both the reactants and the product.

As shown in Fig. 2.3 the ensuing reaction may be between two chemisorbed molecules (Langmuir-Hinshelwood Mechanism) or between a chemisorbed molecule and a molecule in the gas-phase (Eley-Rideal Mechanism). Relative strength of adsorption, availability and nature of bonds, surface temperature, and surface heterogeneity are some of the major factors that dictate the mode of surface reaction favored by a

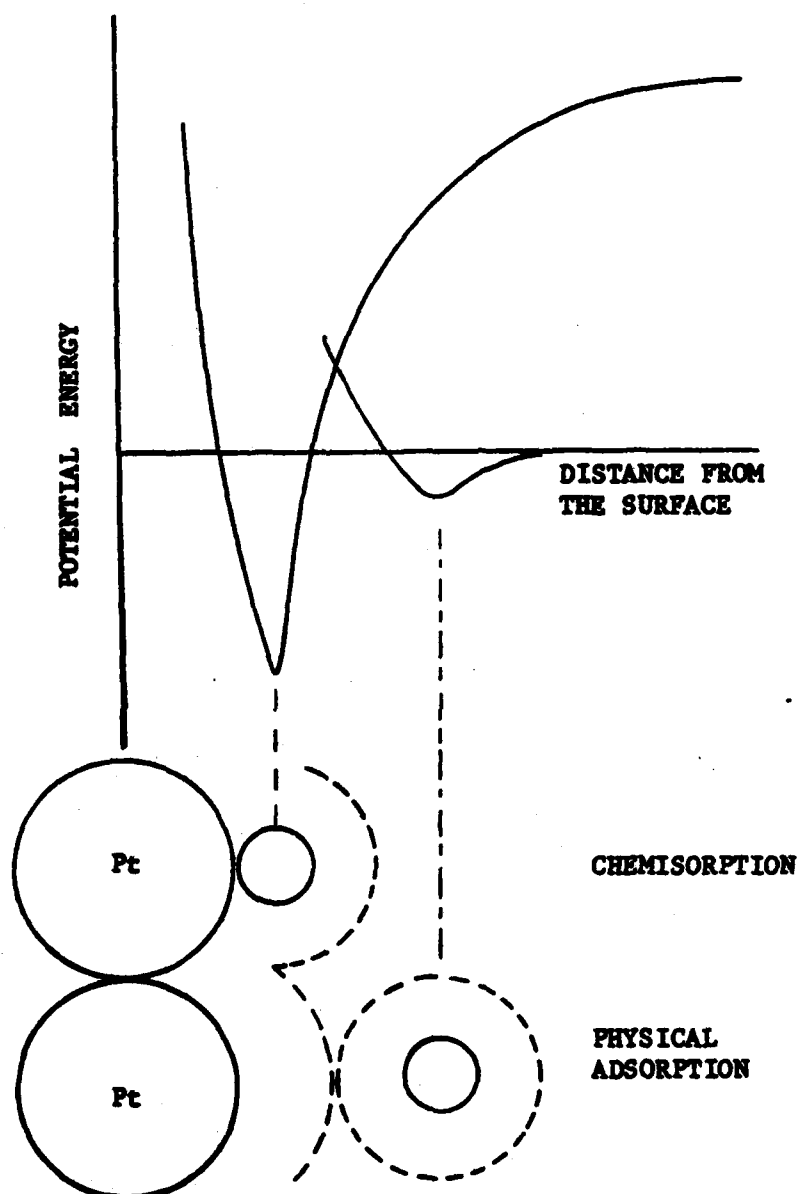

Figure 2.4 Potential energy curves for the physical and chemical adsorption

given combination of reactants and catalyst.

The product formed would then desorb from the surface before diffusing back into the ambience. Again, the desorption is an activated process such that its rate is governed by the same factors discussed for the chemisorption.

### 2.1.3 Reaction Limits

Out of five individual steps the first and the last are mass transport processes of diffusion - a purely physical process whereby the reactants or products are brought to and from catalyst. The adsorption, reaction and desorption are all chemical processes with unique activation energy associated with each step. Any one of the five steps can be the bottleneck which determines the overall rate of reaction. In one extreme the reaction rate may be limited by one of the chemical processes at the surface in spite of ample supply of the reactants from the gas-phase. The kinetic limit is, then, a situation in which the maximum surface coverage of reactant is always maintained (that is, the reaction rate is independent of the gas-phase concentration) and the observed activation energy represents the true kinetics at the surface.

In the other extreme the reaction rate may be so fast that the reactants are consumed as they are brought to the surface. The overall rate is limited by mass transport and the apparent activation energy is usually much lower than the true activation energy. In fact the associated rate, being limited by diffusion, would rather vary with temperature to the half power rather than obey Arrhenius kinetics. In

addition, the rate of mass transport-limited reaction can be increased by increasing the gas-phase reactant concentration (enhancing diffusive transport) and the gross movement of gas (enhancing convective transport). The transition is shown to occur quite abruptly because the reaction rate increases in the Arrhenius fashion while the diffusion rate is a relatively weak function of temperature. Since the observed rate is the slower of the two processes, the mass transport limit is encountered in the high temperature range. The condition conducive to kinetically controlled regime is obtained at the lower temperatures. Figure 2.5 shows an Arrhenius plot indicating the transition of the rate from kinetic limit to mass transport limit.

When catalyzed reactions are studied over a broad range of temperature an Arrhenius plot as shown in Fig. 2.6 can be obtained due to an entirely different cause (Bond, 1974). Even if the supply of reactants from the gas-phase is not limiting, the reaction rate can decrease as the surface temperature is increased when the surface coverage falls below its maximum value. In general the surface coverage increases with the increase in the partial pressure of the adsorbate in the gas-phase at low coverage. The adsorption, being an activated process is also affected by temperature and is usually favored by increasing the temperature in attaining equilibrium. However, adsorption is almost always exothermic because a decrease in free energy accompanies "capturing" of gaseous molecules by the surface. Le Chatelier's Principle, therefore, demands that the rate of desorption be increased with respect to the rate of adsorption so as to nullify the

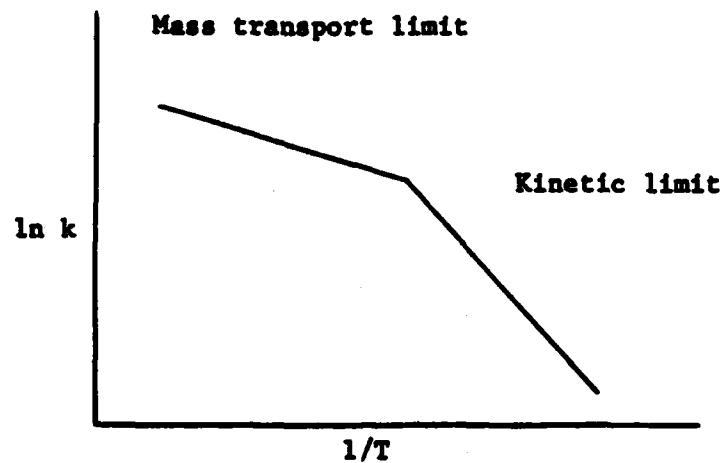

Figure 2.5 Arrhenius plot indicating the transition of the reaction from kinetically controlled to mass transport limited regime

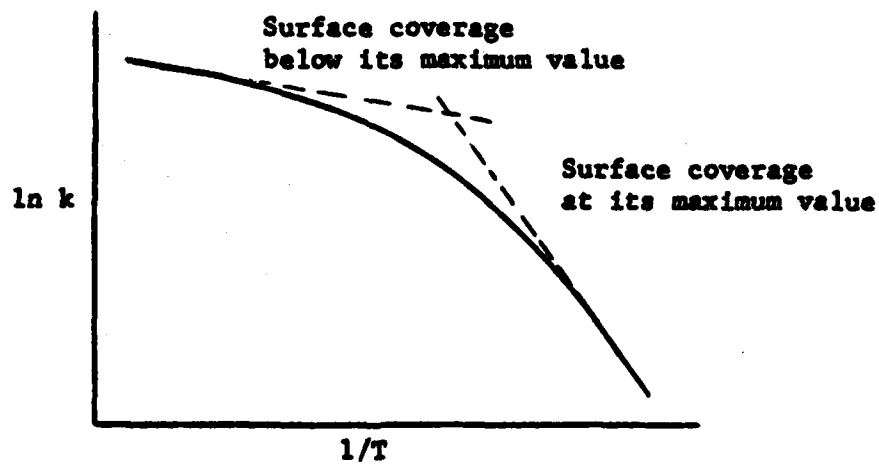

Figure 2.6 Arrhenius plot for the catalytic surface reaction in which the surface coverage by reactants fall below its maximum value

effect of increased temperature. Consequently, an increase in surface temperature can have an adverse effect on the reactant population at the surface.

The possibility of having a negative temperature effect on reaction rates is where the line of thoughts on heterogeneous reaction diverges from that of homogeneous reactions and where the difficulty in determining kinetic parameters of surface catalyzed reactions is best exemplified. Unlike the rate of a homogeneous reaction where the effect of temperature is wholly contained in the rate constant  $k$ , the rate of a heterogeneous reaction feels the effect of temperature through the surface concentration of reactants in addition to  $k$ . Unless the effect of temperature on the surface concentration of reactants is isolated out, the kinetic parameters cannot be extracted from Arrhenius plot.

#### 2.1.4 Adsorption Strength

In addition to surface coverage the structure and stability of the reactant-catalyst complex can also exert profound influence on the reaction rate. For maximum reactivity the adsorption has to be sufficiently strong to maintain a high degree of surface coverage and, at the same time, sufficiently weak to allow brisk reaction with other neighboring adsorbates. Molecules with exceptional adsorption strength can, in the limit, form a complete monolayer over the catalyst surface and thereby shielding it from other reactants, or form a "semi-permanent" bond with the catalyst. In either case the catalyst is disabled and said to be poisoned.

With some exceptions the sequence of the adsorption strength of a number of gases on metallic catalysts are as follows:



Generally the molecules that are unsaturated seem to readily adsorb on the surface in contrast to the saturated hydrocarbon fuels which are not easily adsorbed. Since the hydrocarbons are dissociatively adsorbed on platinum surface by removing a hydrogen atom, the difference in the adsorption strength within the hydrocarbon group is best explained by considering the molecular structure of the reactant. However, studies on the nature of adsorption are usually conducted by using an uncontaminated catalyst under very low pressure conditions and, therefore, may not accurately describe the state of adsorbates under reaction conditions (Kasemo and Keck, 1980; Mummy and Schmidt, 1980; Krebs et al., 1979). What is more relevant is, perhaps, their relative adsorption strength. It is reasonable to expect that the preferential adsorption of oxygen over saturated hydrocarbon (HC) fuels on platinum may well cause the mixture to manifest quite different reaction behavior from mixtures of oxygen and unsaturated HC fuels. Since both oxygen and unsaturated HC fuels have strong affinity for platinum surface, the interaction between these molecules would be competitive rather than preferential, vying for the same catalytic sites.

## 2.2 FROM MICROSCOPIC TO MACROSCOPIC LEVEL

The effect of the differences in the behavior of molecules at the microscopic level are evident at macroscopic level. For example, the

reaction order of a surface catalyzed reaction can be correlated with the heat of adsorption. Generally, an inverse relationship has been found between the heat of adsorption and the reaction order. As will be demonstrated in this thesis, a qualitative correlation can also be made between the ignition temperature of fuel/air mixtures and the adsorption strength. Furthermore, a slight variation in the catalytic reaction mechanism may induce homogeneous as well as heterogeneous reactions. This homogeneous-heterogeneous hybridized reaction can be illustrated by considering a catalytic isothermal surface exposed to a steady flow of combustible mixtures. The reaction can proceed in two different mechanisms. The catalyst may simply facilitate oxidation of the fuel at the surface, producing heat and combustion products. The heat of oxidation generated at the surface reduces the amount of heating required to maintain the surface at a constant temperature, but it does not contribute to facilitating the gas-phase ignition. In fact the depletion of this fraction of chemical energy from the gas stream represented by reductions in the reactant concentrations near the surface, would render the gas-phase ignition more difficult to be achieved when compared with the inert, isothermal case. The gas-phase activation energy, however, would remain the same. The fact that a catalytic, isothermal surface inhibits rather than promotes ignition was first observed by Coward and Guast (1922) and recently analytically demonstrated to be possible by Law (1981).

On the other hand, desorption of activated complexes before surface reaction is also possible. These complexes would diffuse into the gas

medium and initiate the gas-phase reaction. In this case, then, gas phase ignition is likely to be facilitated and the gas-phase activation energy is also expected to be significantly reduced.

The above discussion clearly demonstrates that understanding of catalytically-supported gas-phase combustion requires detailed knowledge of the surface kinetic processes.

## CHAPTER 3

### EXPERIMENTAL CONSIDERATIONS

#### 3.1 METHODOLOGY

A great deal of basic research has been conducted in the area of surface science and organometallic chemistry. Most of the kinetic data for catalytic reactions are obtained through chemical analysis of reactants and products by mass spectrometer or gas chromatography. Another standard method is monitoring the reactant concentration in a reactor over a period of time by measuring changes in partial pressure, refractive index, thermal conductivity and other physical or chemical properties. Meanwhile, progress in vacuum technology and sub-atomic instrumentation had a direct impact on the direction of experimental investigations.

A few examples of the popular techniques used are low energy electron diffraction (LEED) for measuring surface structures, ultra violet photoelectron spectroscopy (UPS) for the electron property of adsorbates, and thermal desorption spectroscopy (TDS) for the energetics of adsorption. Consequently, exhaustive data have been accumulated on adsorption and desorption rates, sticking probabilities, effect of surface coverage, and the nature of interactions of the adsorbed species, under well defined conditions of ultra high vacuum and usually over a single crystal with specific lattice orientation. Based on these data a number of adsorption isotherms have been proposed to relate the surface coverage as function of pressure and temperature of the ambient gas. Different surface reaction mechanisms have also been modeled and

tested.

However, research in combustion cannot take full advantage of the existing knowledge compiled from microscopic analysis because combustion phenomena in the real world occur at atmospheric or super-atmospheric conditions. A simple extrapolation of the existing data to fill the "pressure gap" is not acceptable because catalytic processes involve interactions between the surface sites and the adsorbed species; their behavior is governed not only by physical and chemical properties but also by the arbitrarily imposed conditions of pre-treatment and fluid dynamics.

Recently micro-calorimetric methods have been developed which enable direct measurement of the rates, orders and apparent activation energies of heterogeneous catalytic reactions measured in terms of chemical heat liberated at the catalyst surface. Although the information so obtained is considered to be crude by vacuum technology standards, it is nevertheless a powerful method in an attempt to bridge the gap between engineering and basic sciences.

### 3.1.1 The Development of Micro-Calorimetry

The micro-calorimetric technique has been used extensively in various fields of research as a means of measuring a small amount of heat flow. The first adaptation of this technique to the problem of catalytic reaction is usually credited to Firth (1966) who has studied catalytic oxidation of methane on palladium-gold alloys. Their system consists of a heating coil imbedded in a bead of alumina whose surface

is coated with a thin layer of catalyst. The calorimeter forms one arm of a Wheatstone bridge which is initially balanced in a non-reacting flow. The heat released at the catalytic surface due to the chemical reaction is measured from the extent of imbalance in the bridge network since the surface temperature is translated into an increased resistance value of the calorimeter. A number of investigations using calorimetric bead system (Firth and Holland, 1968, 1969; Cullis et al., 1970, 1972) ensued in the study of oxidative reaction of methane.

In order to overcome the inconvenience of the need to compensate for the variation of reaction rate with changes in the surface temperature, an isothermal method has been proposed by Jones et al. (1974). This improved concept involves measuring the changes in power consumption in the reacting and non-reacting conditions. However, this system is not suitable when the power generated by reaction is small compared to the power necessary to maintain the bead at the reaction temperature. This is because the signal to be measured is a small difference between two large numbers - a situation which is prone to large errors. Also, due to the large mass of the bead, the calorimetric bead system is inherently slow in response.

The catalytic system can be made more sensitive by using a bare platinum wire. In fact, earliest works on the existence of multiple steady states for heterogeneous catalytic reactions were conducted with catalysts in a simple wire form (Buben, 1945). However, it is only from the late 1960's when catalytic wire is used in the capacity of micro-calorimeter.

Two modes of operation have since appeared. In the heated-gas technique (Cardoso and Luss, 1969) the surface temperature of the catalyst is determined by the pre-heated gas mixture. For non-reactive conditions the catalyst surface temperature is the same as that of the gas mixture. But in the presence of catalytic reactions the surface temperature reaches a value higher than the ambience. Ignition is then identified at the transition when the catalyst breaks out of the temperature equilibrium with the surrounding. The heat release rates are obtained after a series of similar runs made with varying gas temperatures in reacting and non-reacting conditions.

In the heated-wire technique it is the catalyst itself that is the active heating element. The gas mixture is heated only locally at the catalyst surface by the wire. As Edwards et al. (1973) point out, the heated-gas technique provides a more uniform wire temperature due to total absence of axial heat conduction loss at the ends of the wire. However, it is the heated-wire technique that has been favored by many researchers and has, consequently, evolved into a viable method of extracting kinetic data out of catalytic reactions. It is also the technique adopted by this research. The underlying concept and the methodology of this technique will be discussed in detail in the following section.

### 3.1.2 Basis of Heated-Wire Technique

The principle of the heated-wire mode of micro-calorimetry is the same as that of the constant-temperature hot-wire anemometry. While the

anemometer is used to measure rapidly varying flow velocities from known heat transfer characteristics, the micro-calorimeter is used to measure the rate of heat transfer in a steady, known flow field.

When a platinum wire immersed in a steady non-reactive gas stream and heated by passing electric current through it, its surface temperature is uniquely determined from the equilibrium of Joulian heat generation and the heat loss due to radiation, conduction and convection to the oncoming gas stream. The power required to maintain the surface temperature at  $T_s$  will be  $P = I^2 R_w$ , where  $I$  is the current through the wire and  $R_w$  is the wire resistance at  $T_s$ . Both quantities can be measured using conventional instruments and the power requirement is shown as a solid line in Fig. 3.1 where a graphical representation of the heated-wire technique is illustrated.

When the gas stream is made reactive with an addition of a small amount of fuel, some chemical heat is generated at the surface such that less electrical heating is needed to maintain the surface at the same temperature  $T_s$ . Furthermore, since the amount of fuel addition is small, a small addition of fuel the thermodynamic and heat transfer properties of the reactive gas flow do not deviate much from those of non-reactive gas flows. The heat loss can then be assumed to remain unchanged and, as the result, the difference in the power requirements is an accurate measurement of the chemical heat release rate. The catalyst now serves an additional function as a reaction sensor.

The first use of this technique in a related work has been reported by Hiam et al. (1968), who suggest that the kinetic parameter of

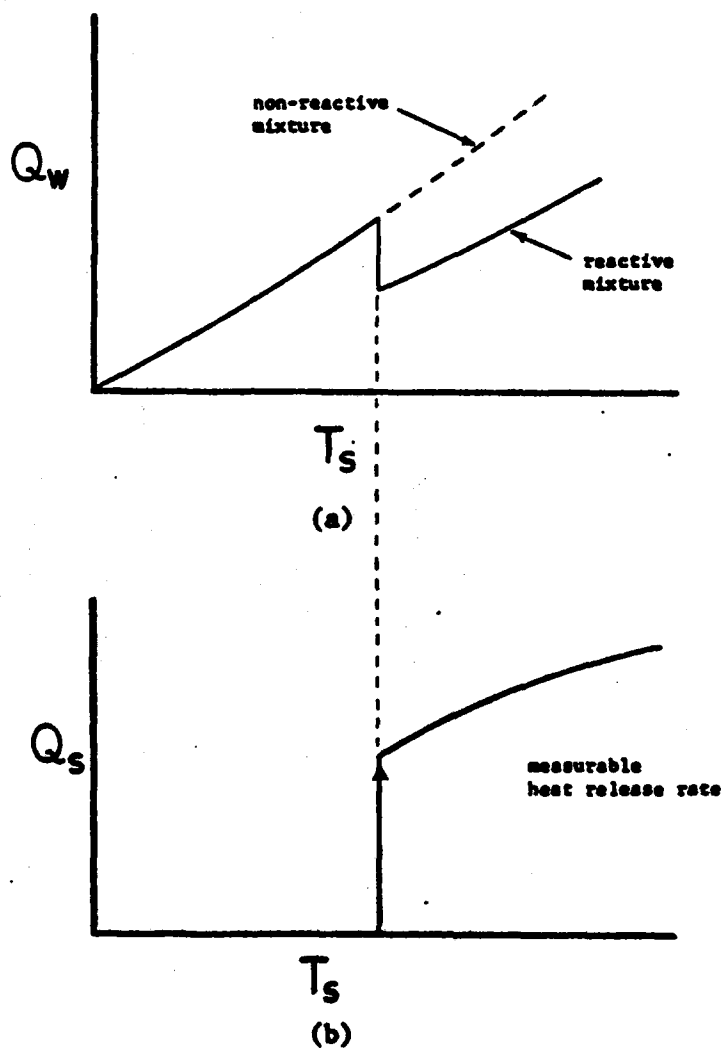

Figure 3.1 Pictorial representation of the heated-wire calorimetric technique: (a) Electrical power requirement for the catalyst in reacting (broken line) and non-reacting (solid line) environment; (b) the heat release rate obtained from (a)

oxidation reaction of several paraffins can be determined from measuring the ignition temperature. Later Grey et al. (1979) took advantage of the high sensitivity and rapid response of the isothermal bare platinum wire coiled in helix to study oscillatory poisoning behavior during carbon monoxide oxidation.

In an effort to command a greater flow control and incorporate precise analysis, a variation of the above technique is to have the catalyst/sensor prepared in a thin film by depositing catalytic material on a ceramic substrate. When compared to the catalyst/sensor in a wire geometry, the film geometry has the following advantages:

- a) It gives greater sensitivity because it has a far greater surface to volume ratio for a given mass.
- b) A higher degree of control over the catalyst surface characteristics can be obtained while preparing the catalyst/sensor by changing the deposition rate of the catalytic material, pressure, and temperature.
- c) The flow field around the catalyst can be correctly accounted for in analysis.

The heated-film micro-calorimetric technique has been used by Robben et al. (1977) to study catalyzed combustion of hydrogen/air mixtures in a flat plate boundary layer. Activation energy and the pre-exponential constants are determined from the heat release rate measurements in conjunction with numerical computation of the boundary layer combustion model. Recently, Ablow et al. (1980) applied it in a stagnation point boundary layer for propane/air mixtures. No kinetic parameter is

deduced from their investigation.

In spite of the aforementioned advantages the wire geometry remains as a practical alternative to more sophisticated film geometry and as the chosen technique of this research for the following reasons:

- a) Wire geometry is easier to construct.
- b) Great ruggedness and higher stability allow the catalyst/sensor to be subjected to harsher testing environments.
- c) It gives more accurate measurement of surface temperature.
- d) It is less susceptible to physical changes with time.
- e) And, most importantly, the flow field around the wire can be equally well characterized and a steady state process may be assumed for the (slow) flow rate considered here.

The last point will be elaborated in the following section.

### 3.1.3 Flow Field Around the Catalyst

Two different approaches can be classified depending on the flow configuration of the combustible mixture with respect to the catalyst geometry (see Figs. 3.2 and 3.3). The first category involves flow along a flat plate or through a honeycomb structure. The process is evolutionary in nature in that the catalytic activity and thereby the temperature and the species concentration profiles continuously change in the streamwise direction. The intimate interaction between upstream and downstream properties necessarily complicates the system behavior and thus data interpretation. Furthermore, if data is collected only at the downstream end of the catalyst (e.g. the honeycomb exit plane), then

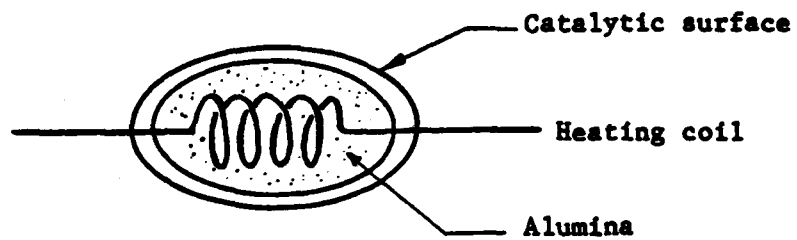

(a)

Calorimetric Bead



(b)

Simple wire coiled in helix

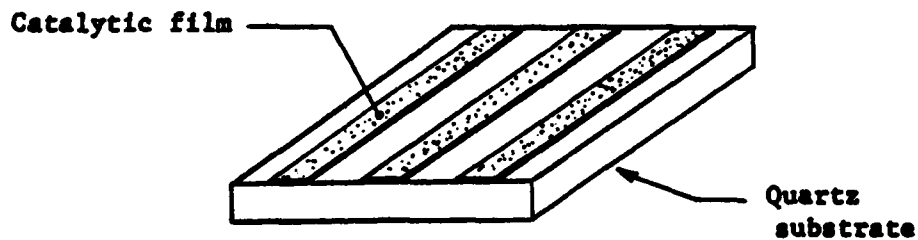

(c)

Catalytic film deposited on  
quartz substrate

Figure 3.2 Summary of the catalyst configuration

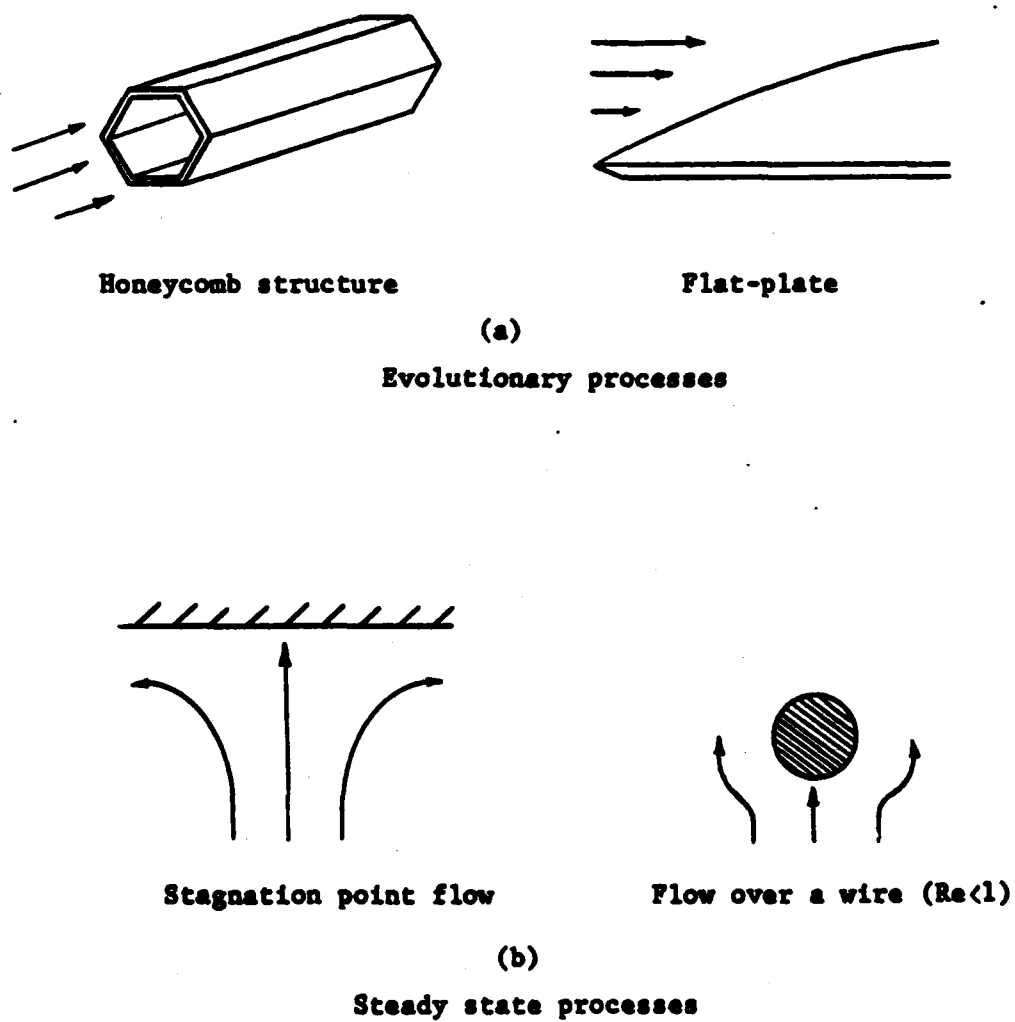

Figure 3.3 Flow field around the catalysts

the integrated nature of the data would render unambiguous data resolution difficult.

The second category involves the stagnation-point flow, in which self-similarity prevails, and the low Reynolds number flow over a thin wire, in which the catalyst can be considered to be immersed in a constant concentration bath. For these systems a single catalytic response exists for a given flow-catalyst combination, thereby enhancing the fidelity of the data and subsequently its interpretation.

Representatives of the former approach are the honeycomb experiments of Prasad and co-workers (Prasad, Kennedy & Ruckenstein, 1980; Prasad, Tsai, Kennedy & Ruckenstein, 1981) and the flat plate experiments of Robben and co-workers (Robben, Schefer, Agrawal & Namer, 1977; Schefer, Robben & Cheng, 1980). For the flat-plate flow much effort was expended to spatially resolve the boundary layer structure with and without chemical reaction along the catalyst surface by using laser diagnostic techniques and gas sampling. A representative of the latter approach is shown in the work by Ablow et al. (1980) where a stagnation-point boundary layer flow of lean propane/air mixture is investigated. The measured quantities are the total heat release rates in the diffusion controlled regime. Relative contributions from gas-phase reactions and surface reactions are examined with the aid of theoretical analysis. However, the relevant kinetic parameters are not identified in this study.

A detailed examination of the existing data also reveals that little study has been conducted to quantify the effect of flow velocity

on catalytic activities. Most studies are carried out with an arbitrarily fixed flow rate or in the flow range where velocity is yet another parameter to control. Marteney and Kesten (1981), have experimentally demonstrated that the ignition temperature approaches a constant value as the flow velocity is decreased. Although their system is a platinum on cordierite monolith the same trend is to be expected for the wire configuration. Thus in order to further quantify the effects due to flow velocity variations, a series of experiments has been conducted in the present study and is discussed in Section 4.5.1 and 5.3.1

### 3.2 EXPERIMENTAL FACILITIES

An elaborate flow system, electronic control system and computer data acquisition system are designed and constructed to accommodate all facets of the experimental investigation. The major strength of the experimental facility is in its capability to monitor the major experimental parameters independently and to do so with minimum system error.

#### 3.2.1 Flow System

The schematic diagram of the flow system is shown in Fig. 3.4. The test chamber, Fig. 3.5, is the active center of the set-up and is basically a multi-purpose space (6" x 6" x 15-1/2") where a catalyst of any shape can be installed in any desired configuration with respect to the oncoming flow. For example a flow over a simple wire, flow over a

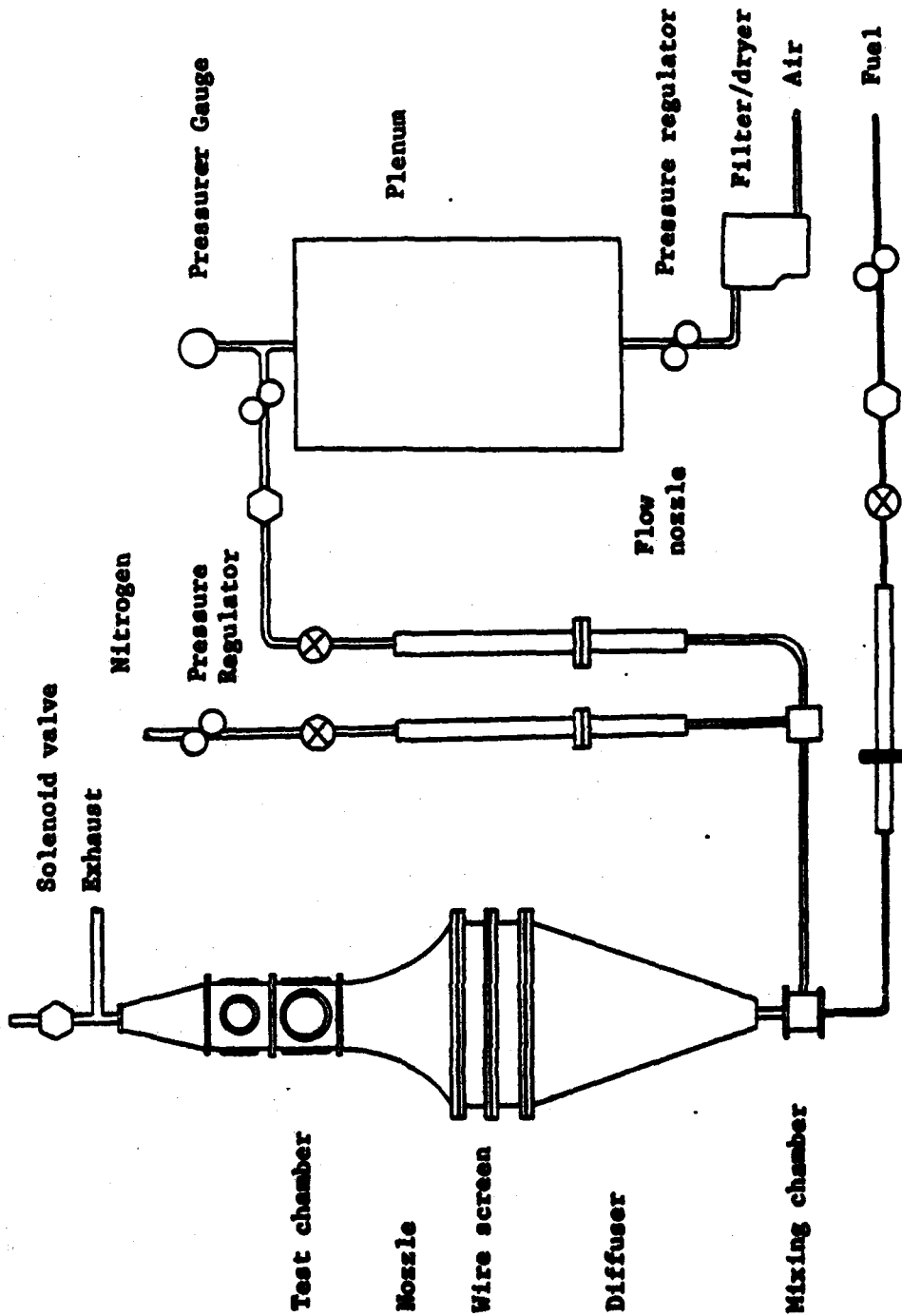

Figure 3.4 Schematic diagram of the flow system

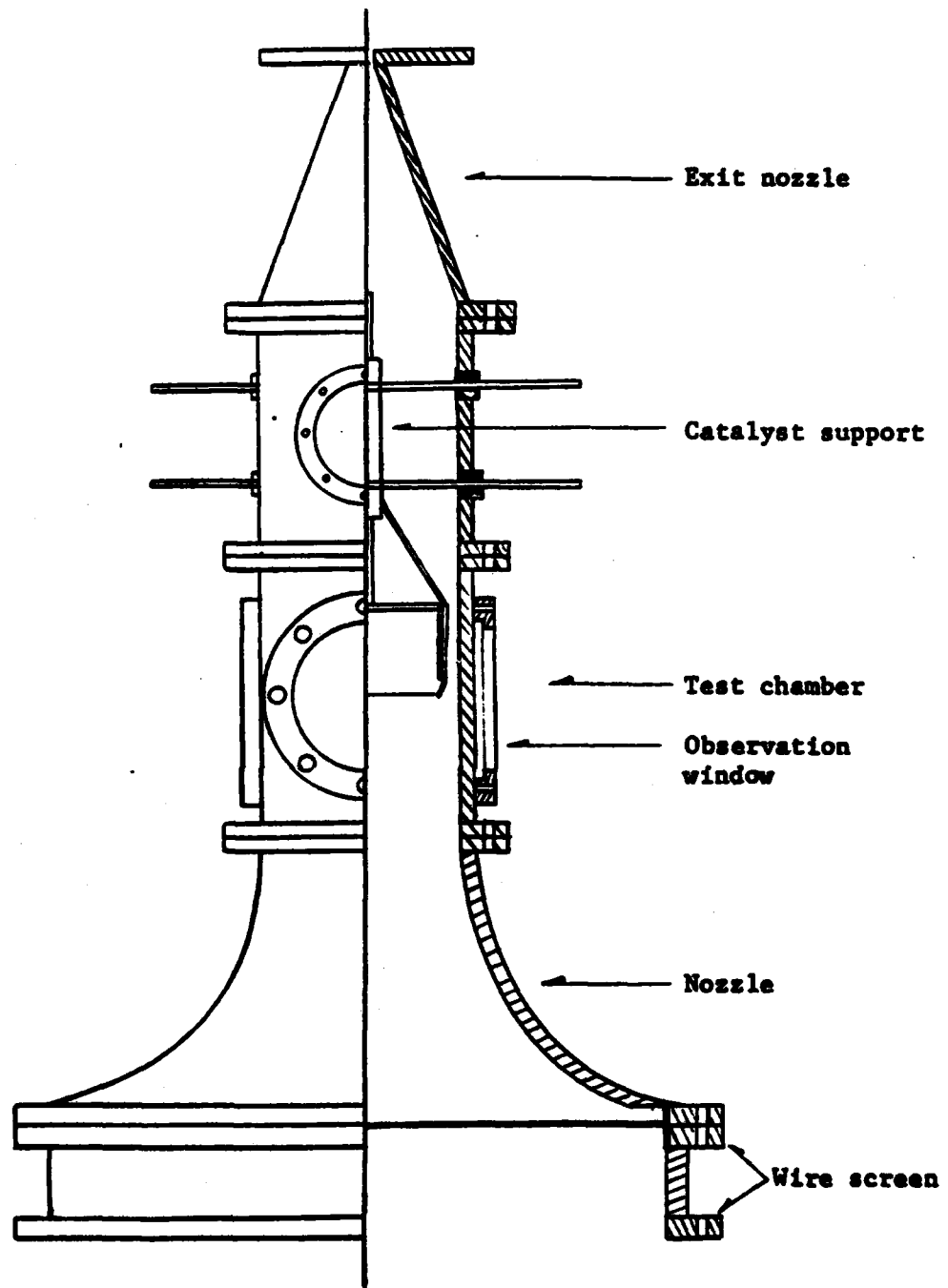

Figure 3.5 Section diagram of the test chamber

flat-plate, or a stagnation point flow can all be maintained with minimum downstream disturbance. The length of the test chamber allows the catalyst support system to be located far downstream. The test chamber is further divided into three compartments such that any section of the test area is easily accessible from all angles. Large viewing windows enable complete visualization of the interior of the test chamber.

House air, supplied at 3 atms, is the source of oxidizer. It passes through an air filter/dryer to eliminate moisture and dust particles. This process is essential to preserve the constancy of the catalyst surface and, therefore, the repeatability of the data. Air then passes through a first stage pressure regulator before entering a plenum tank where any residual pressure fluctuations from the main supply line is completely damped out. A second pressure regulator monitors the air flow rate through the flow nozzle which constitutes the flow metering system.

An exhaustive calibration scheme has been carried out to determine the actual flow rate into the test chamber, using flow nozzles operating in the choked condition such that the flow rate depends only on the upstream conditions. Physical volume displacement method is used to calibrate the flow nozzles for air, nitrogen and fuels except butane which has low saturation pressure. Butane is calibrated against the standard wet test meter.

The design of the mixing chamber is crucial, for it must provide a homogeneous mixture in a short time period. The mixing process follows

two stages. Air and nitrogen are mixed first and enter the mixing chamber through two separate ports (Fig. 3.6). A jet of fuel is injected through the third port oriented at right angles to the air/N<sub>2</sub> streams. The mixing chamber is packed with glass beads to provide initial mixing at the gross scale. Fine mixing is achieved by turbulence as the mixture is suddenly expanded into a long diffuser. The turbulence created in the mixing process is quickly suppressed as it passes through a series of wire screens whose mesh size progressively decreases.

The last stage of flow control is the converging nozzle whose area reduction ratio of 8 ensures a full development of flow with a uniform velocity profile in the test chamber. A smooth exhaust of the flow is provided by a converging section at the downstream of the test chamber.

The whole flow chamber is constructed with 3/4" thick stainless steel and other subsidiaries are of the material equivalent in strength to withstand high pressure (5 atm). Low vacuum construction specifications are also adhered such that the experiment may also be conducted in sub-atmospheric conditions.

### 3.2.2 Electronic System

The heart of the experimental set-up is the electronic circuitry that enables an accurate measurement of the extent of chemical reactivity in the immediate vicinity of the catalyst. As mentioned previously, the basic principle of the feedback operation is that of a constant temperature hot wire anemometer. However, unlike the hot wire

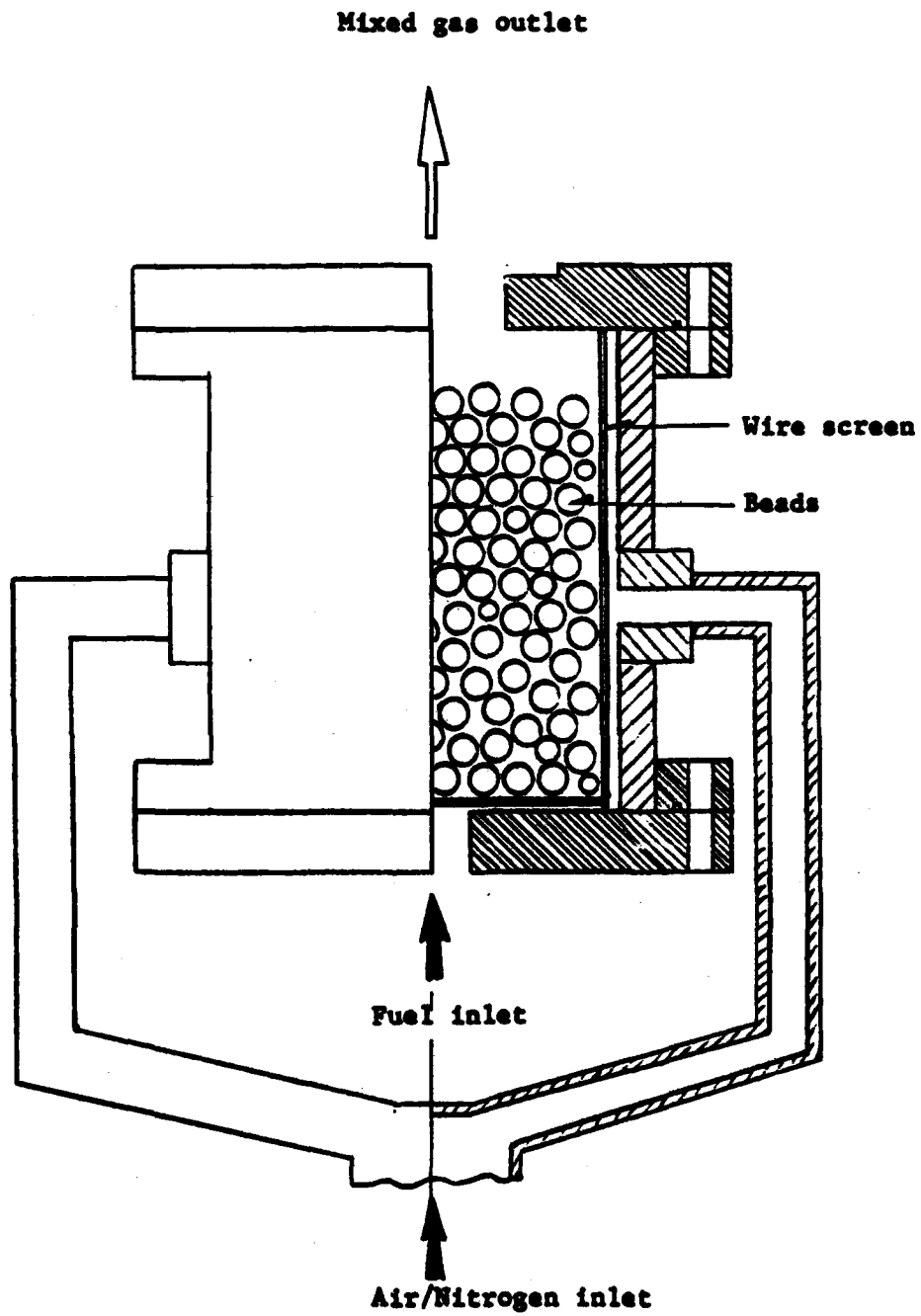

Figure 3.6 Section diagram of the mixing chamber

of the conventional anemometer, our modified version performs four functions simultaneously:

- a) catalyst
- b) constant temperature heater
- c) micro-calorimeter
- d) temperature transducer

Expanding the role of catalyst as a reactor as well as a sensor results in much simplification in the physical configuration of the system. However, as direct consequence of increasing the versatility of the catalyst, the data acquisition system becomes an integral part of the heating power system. That is, the system must have enough capacity (hence, ruggedness) to heat the catalyst to a high temperature favorable for appreciable chemical reaction and, at the same time, must exhibit enough sensitivity to respond to and detect small changes in the power consumption. To satisfy both performance criteria, the following operational procedure has been devised. Simple schematic diagrams of the functional elements and the generalized input-output configuration are shown in Fig. 3.7 and 3.8, respectively.

The logic of the system is as follows:

- a) At thermal equilibrium and when the bridge network is balanced,  $V_p$  solely represents the power required to heat and then maintain the catalyst at a constant temperature.
- b) When a small quantity of fuel is introduced into the air stream, thermal equilibrium is disturbed due to the chemical reactions at the surface of the catalyst.

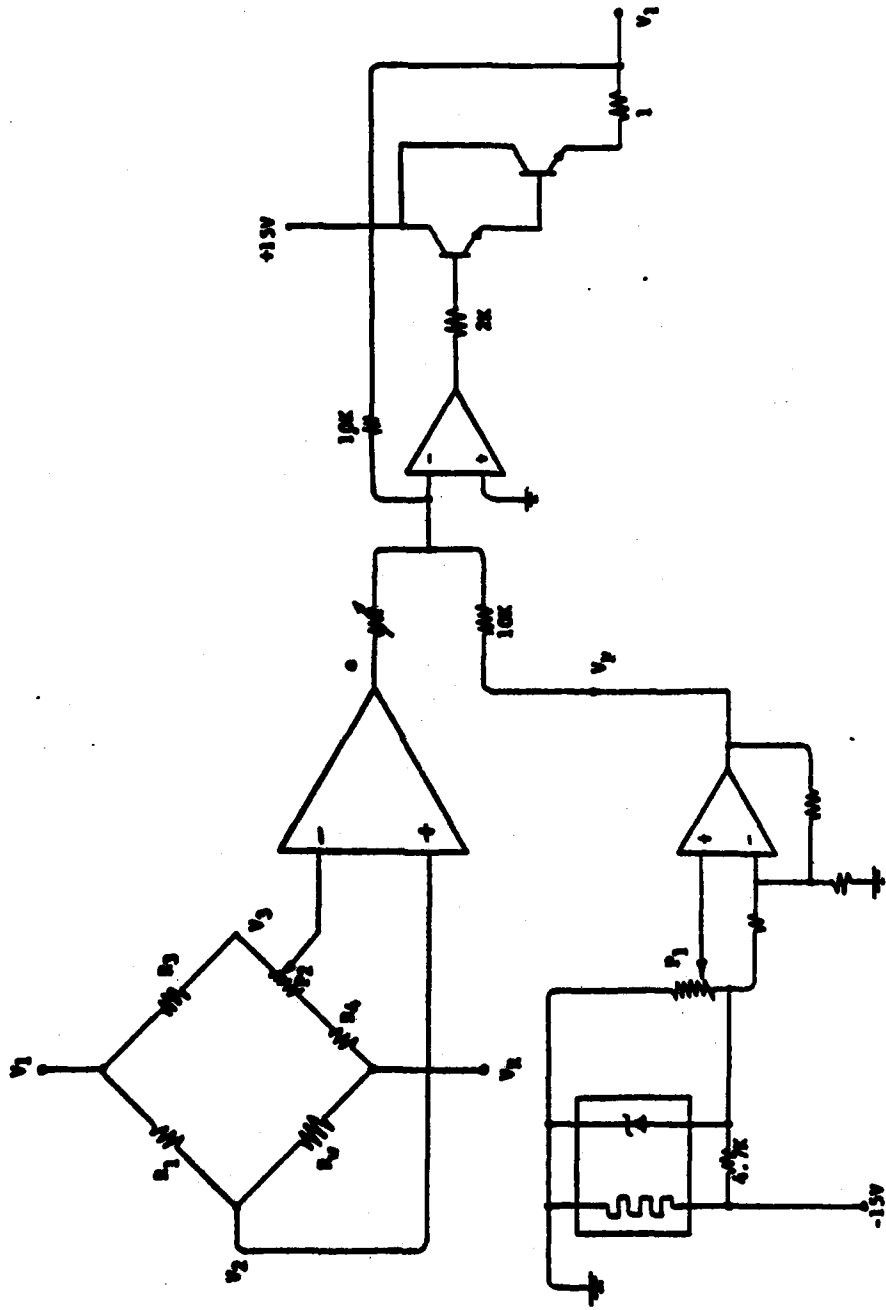

Figure 3.7 Schematic diagram of the functional elements of the electronic system

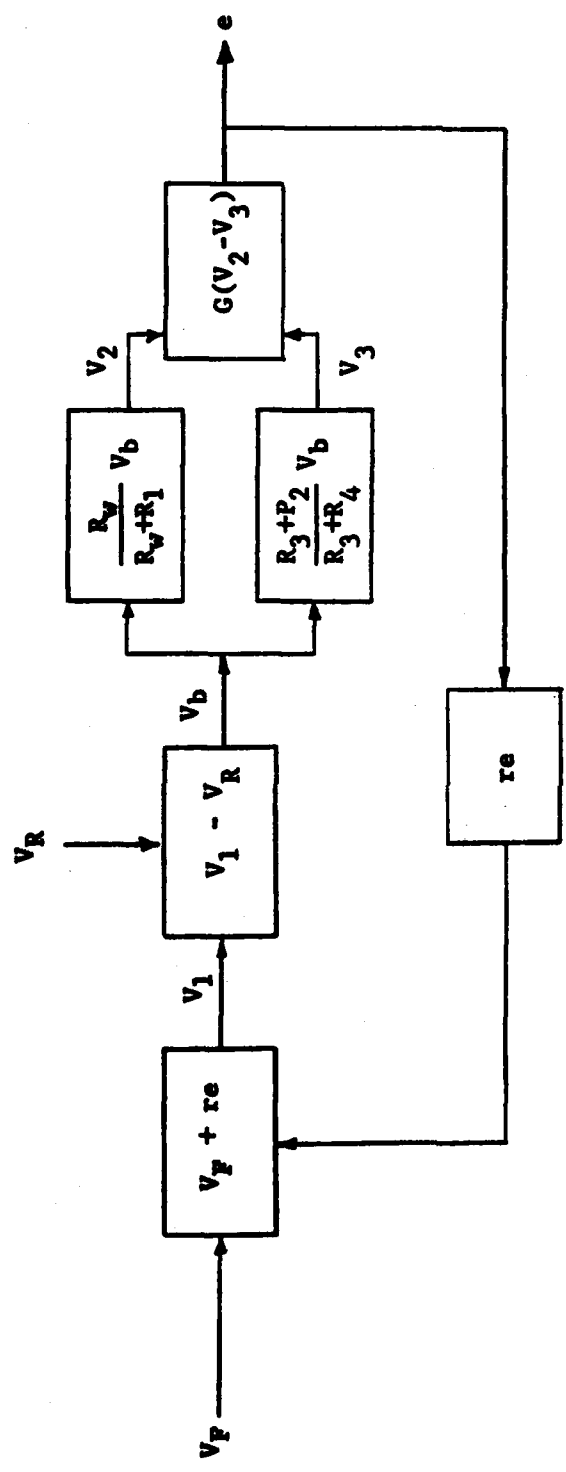

Figure 3.8 Generalized input-output configuration of the control system

- c) The chemical heat release is an extra heat source for the catalyst and, therefore, in the absence of adjustments, the temperature of the catalyst increases.
- d) Since platinum has a relatively large temperature coefficient of resistance, a small increase in temperature is reflected as an increase in its resistance. With the same amount of current flowing through it the voltage  $V_2$  becomes greater than  $V_3$ .
- e) This imbalance in the bridge is detected and amplified by a true instrumentation amplifier.
- f) The output from the amplifier,  $e$ , is a magnified error signal and represents the extent of chemical heat release.
- g) The normalized error signal,  $P_3e$ , modifies the power input into the catalyst and, therefore, reflects the changes in the electrical heating power required to restore the temperature to its original value.
- h) A new thermal equilibrium is achieved while maintaining balance in the bridge network.

Thus, although the voltage output level from the catalyst-the-sensor is a minute portion of the total voltage applied to the catalyst-the-heater, the present system successfully identifies and separates the two signals, facilitating the acquisition and the analysis of data.

Furthermore, only one signal needs to be monitored, unlike other existing measurement system in which at least two signals must be traced simultaneously to quantify the power input into the catalytic wire.

The selection of each electronic element for the feedback circuit

demands detailed attention since it must be able to detect and immediately compensate for small imbalances in the bridge. Ample heat sinks and ventilations are provided to minimize the drift in the electronic system due to heating. The reference resistor in the bridge is a precision, water-cooled, resistor with 3.6 KW heat dissipation capacity. Such resistor ensures a constant reference resistance even when a high current is passing through.

The role of the catalyst as a temperature transducer is possible because the thermal coefficient of the resistance of platinum is large and is well-known. That is, the average surface temperature of the catalyst is calculated from the measurement of its resistance. The thermal coefficients of the platinum used in the equation

$$R_w(t) = R_0(1 + \alpha T + \beta T^2)$$

are

$$\alpha = 3.51 \times 10^{-3}$$

$$\beta = 5.42 \times 10^{-7}$$

The resistance of wire at 20°C,  $R_0$ , is not obtained using ohmmeter as it is not reliable at low resistance values. Instead, the resistance of the wire is measured at various current flows, and then the resistance at room temperature is obtained through extrapolation to zero current flow. Then the above thermal coefficients are once again applied to obtain the value of resistance at 0°C. Figure 3.9 shows the extrapolation.

#### 3.2.4 Data Acquisition System

The electric signals are directly linked to and processed by a

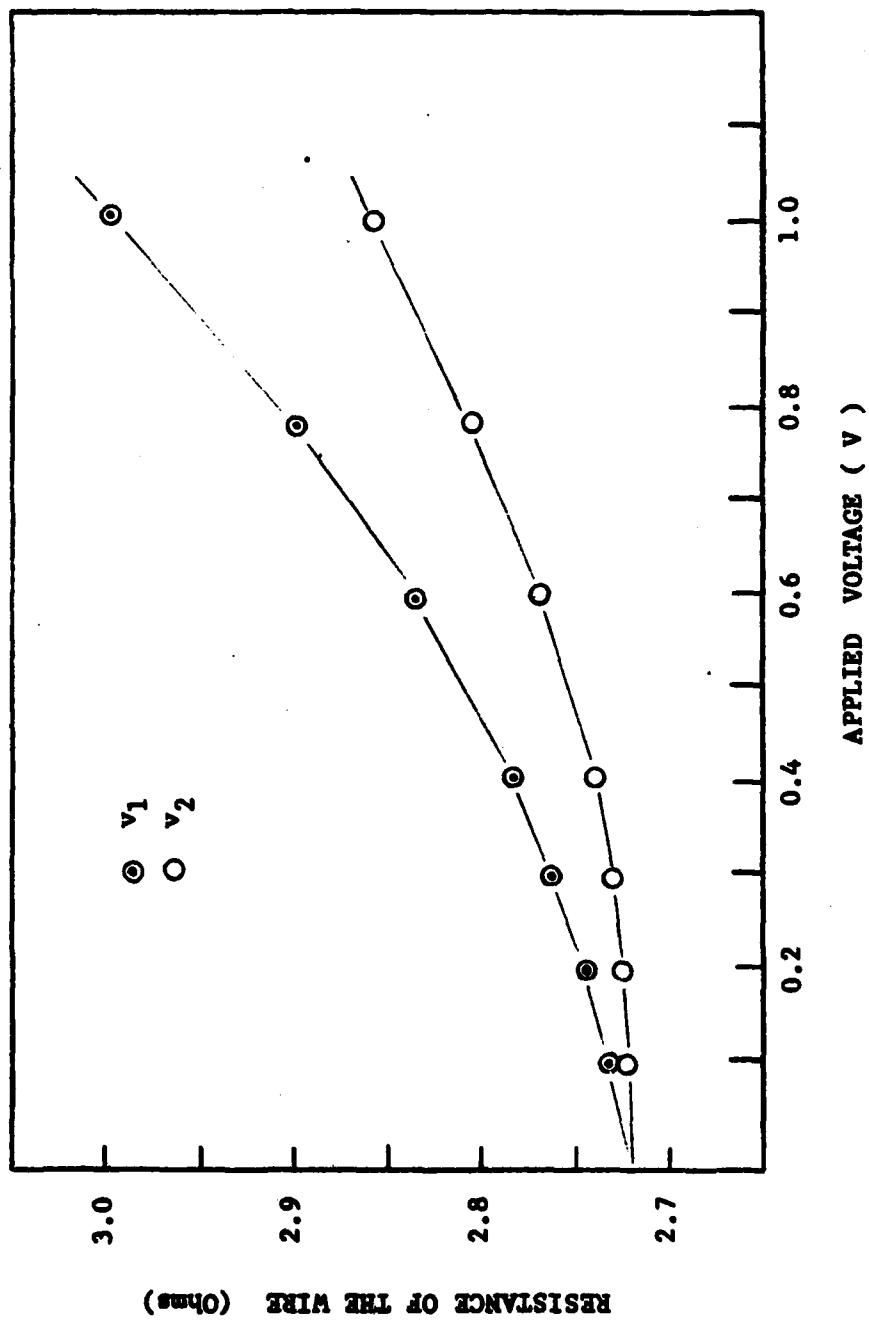

Figure 3.9 Measurement of the resistance of the catalyst at a reference temperature

micro-computer (Fig. 3.10). Figure 3.11 is an example of a typical computer output showing changes in power consumption as fuel is introduced. There are three regions of interest:

- a) The first plateau marks the zero level and the initial thermal equilibrium.
- b) The second plateau, though not always discernible, indicates an increase in power consumption caused by the extra heating required to maintain the wire at the same temperature in the flow that has acquired a slightly higher flow velocity due to fuel addition. Usually this positive change is negligible compared to the heat release rate. Also, the length of this portion is determined by the flow velocity, since it is the time taken for the fuel to flow from the point of induction (mixing chamber) to the initiation of reaction at the reactor.
- c) The third plateau indicates a decrease in power consumption due to catalytic reaction at the wire surface.

The chemical heat release rate is given by the difference in the power consumption represented by the second and the third plateaus.

#### 3.2.4 Catalyst System

The catalyst studied is platinum wire purchased from Material Research Corporation. A minimum purity of 99.99% is guaranteed. Six catalysts are prepared in two geometries. Three are simple straight wires whose axes lie perpendicular to the flow (Fig. 3.12). The other three are coiled in helix of diameter 1.2 mm and pitch of 1.4 mm. In

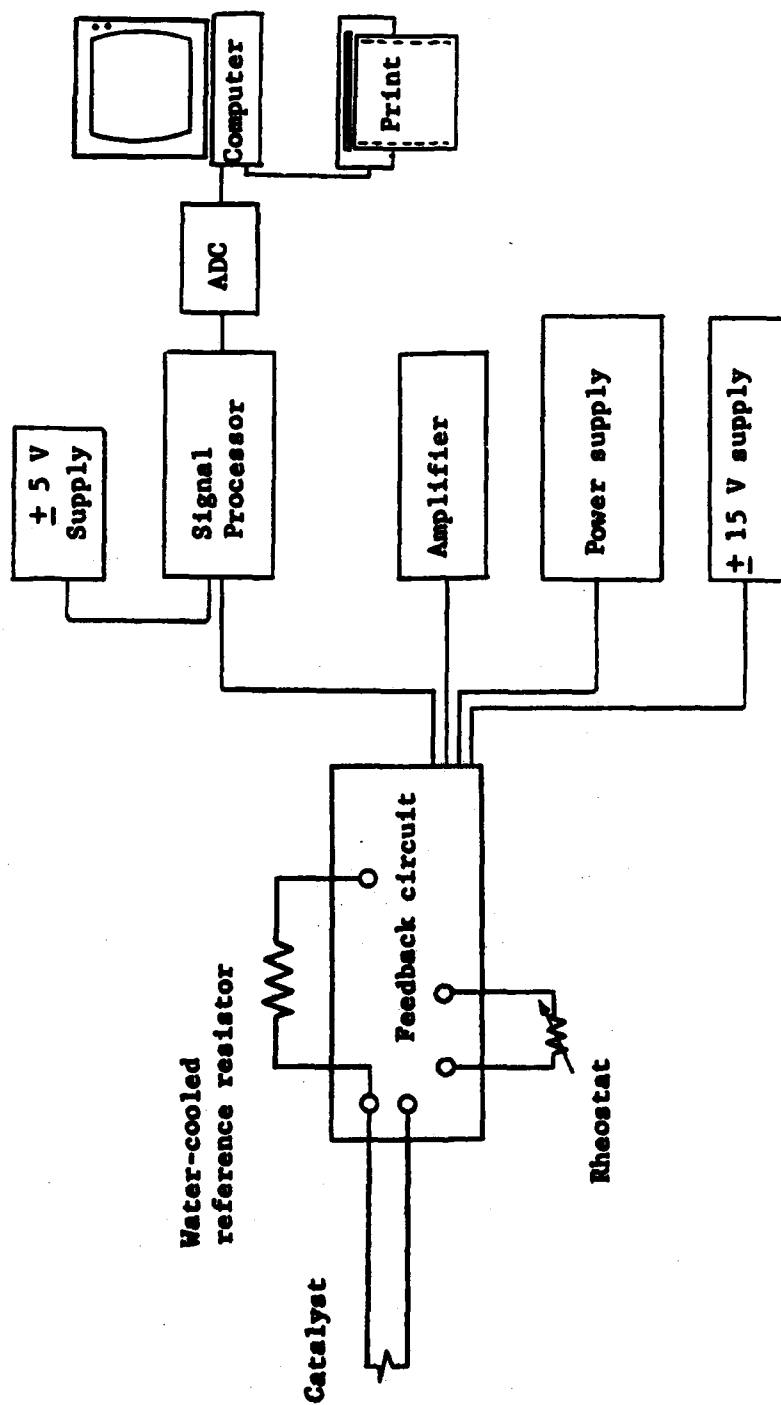

Figure 3.10 Schematic diagram of the data acquisition system

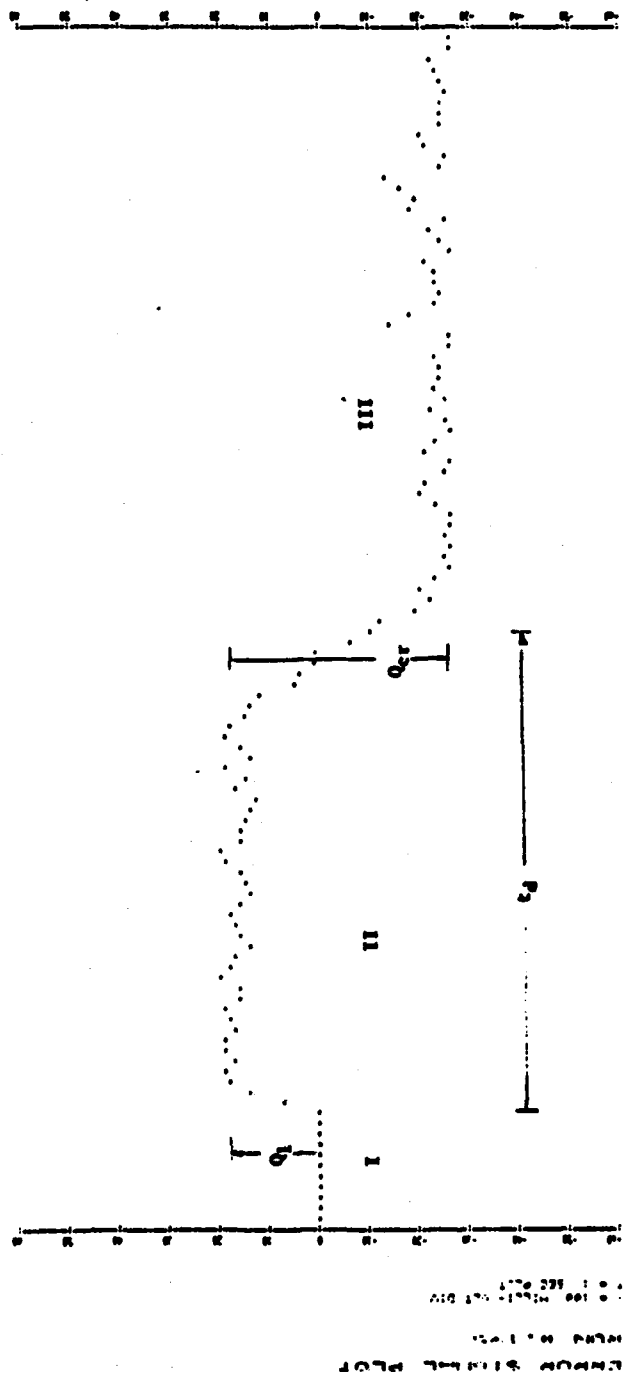

Figure 3.11 Strip chart output of the changes in the power consumption

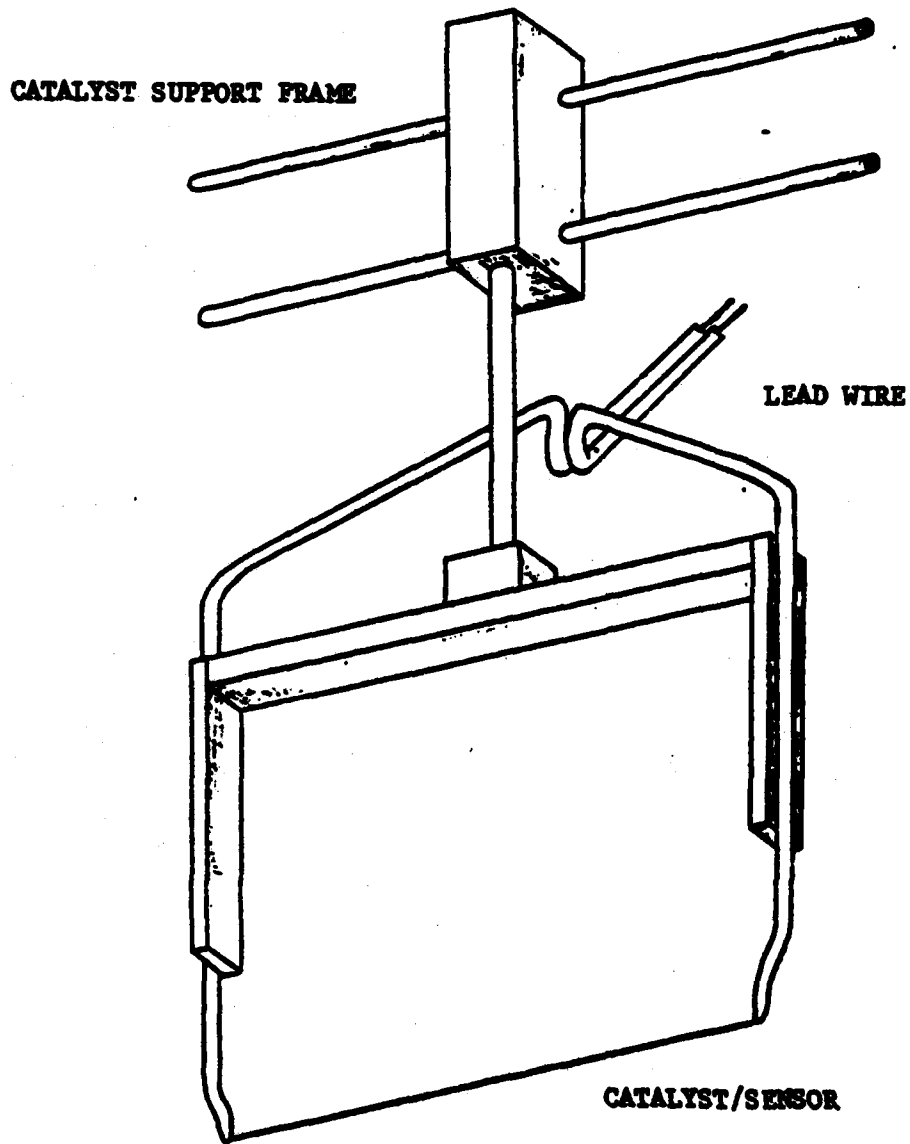

Figure 3.12 Catalyst support system

all cases the diameter of the wire is 0.127 mm.

A brass frame holds the catalyst at two ends. The lead wire is copper soldered to the platinum catalyst.

### 3.3 EXPERIMENTAL PROCEDURES

One of the major difficulties in the study of the kinetics of heterogeneous catalytic combustion is that the experimentally controllable parameters such as the gas-phase fuel concentration and flow velocity do not directly control the surface reaction. That is, since the reaction is confined to a thin layer at and/or next to the surface, the reaction rate is determined by the concentration of the reactants at the surface, which are generally unknown or, at best can only be inferred from their respective gas-phase concentrations. These innate difficulties are compounded by the fact that the catalytic surface cannot be standardized. Catalytic reactivities are based on per unit geometric area which is not an accurate assessment of the actual number of catalytic sites available for the adsorption of reactants; the method of preparation is found to contribute a great deal to producing catalytic surfaces of different roughness. Surface treatments, including sintering and annealing processes at high temperatures, do have effects on the catalytic reactivity. These circumstantial effects on the catalytic reactivity can be minimized or, if inherent, can be well characterized by choosing a suitable set of parameters and conducting the experiment within an outlined procedure.

### 3.3.1 Parameters

The change in the power consumption, which is just the surface chemical heat release, and the ignition temperature are mapped as functions of six variables:

- a) The catalytic surface temperature
- b) The fuel type
- c) The fuel concentration
- d) The oxygen concentration
- e) The flow velocity
- f) The catalyst configuration

The choice of the catalytic surface temperature as a parameter cannot be over-emphasized because of the sensitivity of chemical reactions and surface coverage to temperature variations. It ranges from room temperature to the maximum of 900°C.

The fuel tested are propane, butane, ethylene, propylene, carbon monoxide and hydrogen. There are several reasons for choosing the above six gases. From the practical viewpoint, propane and butane are widely used as heating fuels whereas partial oxidation of ethylene and propylene are important in the petrochemical industry. Furthermore, since their reaction mechanisms are representative of those of the higher order in their respective families, recognizing the basic trends is crucial in understanding the more complex members of the family. In this aspect, the study of hydrogen and carbon monoxide are also important as their oxidation mechanisms form a subset of many hydrocarbon fuel oxidation reactions. The most important reason,

however, is the variety of the chemisorption strength displayed by the above set of gases that makes them interesting to study, as explained earlier.

Both the fuel and oxygen concentrations are varied independent of each other. The total flow rate is maintained by adding nitrogen. The advantages of having fuel/air/nitrogen mixtures with different concentration combinations are quite clear from Fig. 3.13, which shows the possible combination of fuel and oxidizer (oxygen from air) concentrations in the case of hydrogen. Here we note that as long as enough diluent (nitrogen, carbon dioxide or argon) is added any fuel/air mixture is rendered noninflammable, even if the mixture is stoichiometric. The vertical lines represent the constant fuel concentrations while the horizontal lines the constant oxygen concentrations. The slanted lines originating from the lower left corner therefore indicate constant fuel/air ratios. Here, all the points on the same line have the same fuel/air ratio although the absolute concentrations are different. The top boundary is the fuel/air mixture line. As can be easily seen, nitrogen addition has greatly expanded the experimental range, from fuel lean to fuel rich conditions. This flexibility is especially significant when the gas phase fuel/air ratio is not a relevant criterion in heterogeneous reactions.

The dependence of the heat release rate and ignition temperature on the flow velocity and the catalyst shape is traced to substantiate the applicability of the constant concentration concept, as mentioned in

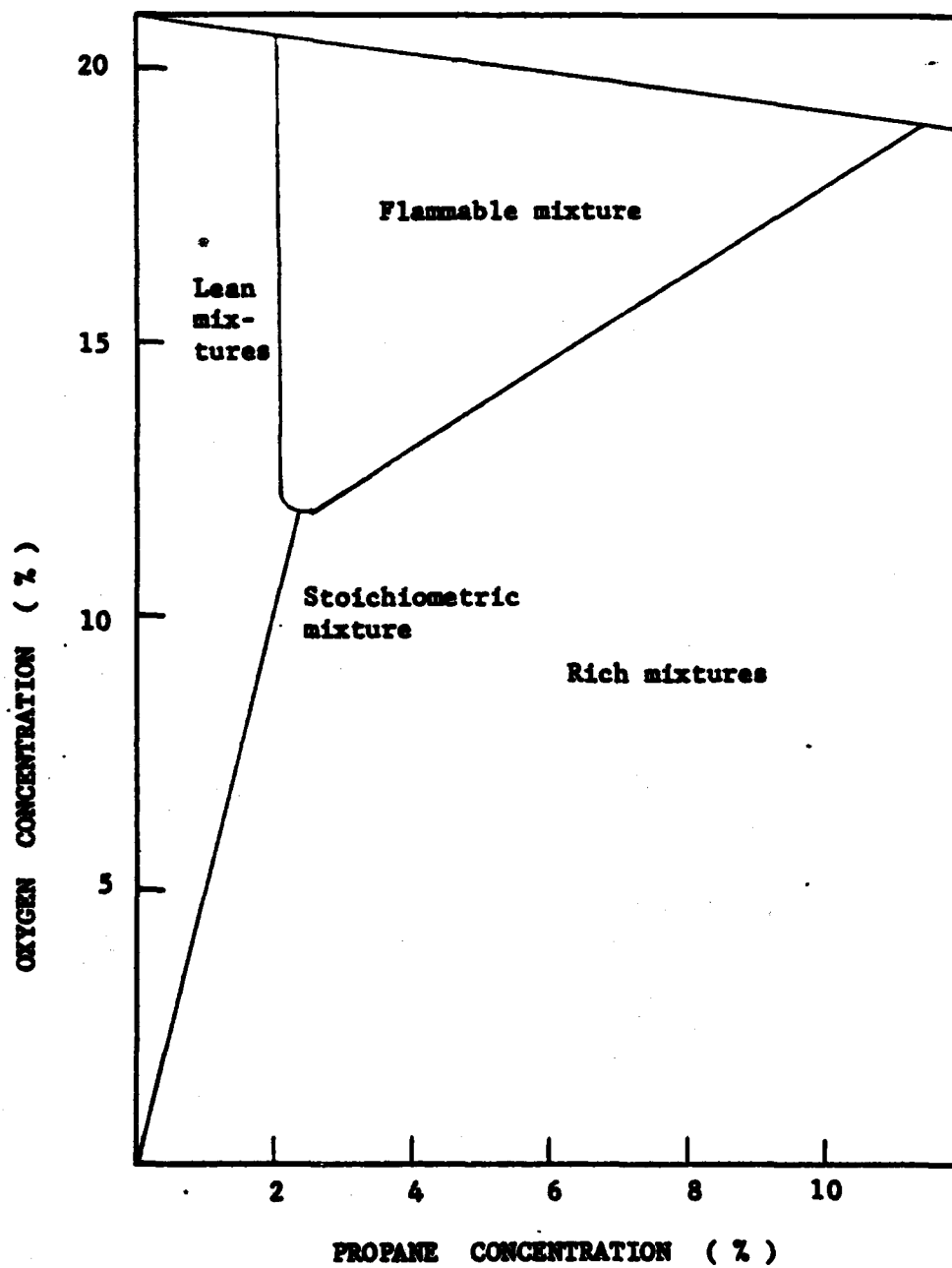

Figure 3.13 The range of propane/oxygen/nitrogen mixtures that can be safely investigated

3.1.3, for low Reynolds number flows.

### 3.3.2 Procedures

"Activation" of fresh platinum wire is the very first step which cannot be by-passed. Depending on the catalyst production method, the "activation" process may be to expose a clean surface by burning away the lubrication oil or to obtain a fixed surface structure through continuous annealing and sintering processes at high temperatures. Rader and Weller (1974) have reported that the "activated" wire shows increased surface roughness when viewed through scanning electron microscope. The activation method they used is heating the wire electrically to 800°C in a 1% butane - 99% oxygen gas mixture for 25 minutes. Edwards et al. (1973) have used similar process to obtain a catalyst whose reactivity does not change for a period up to 8 hours. In both experiments butane is the test fuel. Satterfield and Cortez (1970), in their study of hexane and toluene oxidation, have observed that platinum wire screen loses its reactivity as early as after one hour of operation. They have suggested that the deactivation is caused by oxidation of metal impurities which diffuse to the surface at high temperatures. Reactivity is reported to be fully restored by "prolonged pickling" in concentrated HCl. In this work, fresh platinum wires are electrically heated to 900°C in a reactive mixture of 2% hydrogen/air for 20 minutes. Then, after each run the catalyst is reactivated in air flow. The effect of such process will be reported in Section 4.3.5 dealing with aging effects.

## CHAPTER 4

### IGNITION TEMPERATURE

#### 4.1 DEFINITION

The everyday meaning of the word ignition is "catching on fire". In the field of combustion this highly specialized definition is discarded and, depending on the phenomenon in question, the word ignition can signify different moments in the process of producing an explosion, whether it be a detonation or a deflagration. Catalytic combustion adds yet another meaning to the word ignition. And, in order to clear ambiguities and to examine the possible implications the ignition temperature is unequivocally stated before discussing the data. A brief introduction to ignition theory as applied to homogeneous systems is included for comparison purpose.

##### 4.1.1 Theory of Ignition

Two views have been adopted in the theory of ignition. From the kinetics point of view, ignition is a critical condition in which chain-branching of the radicals proceeds at a high rate such that the production of radicals exceeds the destruction due to chain termination and product formation. Under such volatile circumstances rapid build-up of the radical population is possible even under isothermal conditions; this eventually leads to the formation of products at a catastrophically fast rate. The oxidation mechanisms based on chain-branching are used by Benson (1981), B. F. Gray (1978) and Warnatz (1981) for hydrocarbon oxidation modelling.

The thermal theory of ignition is also based on the idea of imbalance. Instead of focusing on individual groups of molecules, however, the thermal theory deals with the overall result of such interactions, manifested as chemical heat release. Ignition is said to occur when the heat generated by chemical reaction becomes greater than the total heat loss from the system. The excess amount of heat in such a condition is applied towards increasing the temperature of the reactants which in turn leads to higher reactivity. This self accelerative process continues until a heat balance is again achieved at a new, higher temperature. From this point of view, the definition of the ignition temperature becomes more easily quantified as the lowest temperature at which the rate of chemical heat release rate just overcomes the rate of heat loss.

It is obvious that a complete understanding of ignition must necessarily include both the kinetic and thermal effects. Efforts to develop unified chain-thermal theories have just been initiated and are usually numerical in nature.

#### 4.1.2 Catalytic Surface Ignition

Catalytic ignition does not necessarily precede an all-consuming explosion. Nor is it always signaled by a significant temperature rise. Hence ignition temperature is redefined as the lowest temperature at which a measurable amount of heat is released from chemical reaction. Especially in this work, since most of the gas mixtures tested exhibit a rather sudden change in their reactivity over catalyst

surface temperature, the ignition temperature thus identified is an objective and reliable indication of ignition. Unlike the ignited gas-phase reactions, the catalytically ignited reaction may not be self-sustaining. Therefore, catalytic ignition does include neither the concept of thermal runaway nor self-propagation.

#### 4.2 FACTORS GOVERNING CATALYTIC IGNITION

In addition to the obvious importance of knowing when a given gas mixture will ignite, if it occurs at all, the knowledge of ignition temperature may also be applied towards obtaining rate constants of catalytic reactions, as attempted by Hiam et al., (1968). The basis for the possible link between the thermodynamic quantity and kinetic parameters stems from the principle of thermal ignition developed by Frank-Kamenetskii (1955).

Prior to discussing the results of investigations based on such relationships, a careful examination of the key assumptions employed in the initial modelling stage needs to be made. In the following the theory of Frank-Kamenetskii, as extended by Hiam et al., is summarized with an emphasis on discussing the validity of the key assumptions.

##### 4.2.1 Thermal Ignition Analysis

The theory starts with the simplest case in which the reaction rate is first order with respect to the surface concentration of a single reactant

$$(r.r.) = kC_s$$

where  $k$  represents the true kinetics at the surface and  $C_s$  is the surface concentration of the reactant. In the quasi-steady state the rate of reaction is equal to the rate at which the reactant is supplied to the surface by diffusion

$$(r.r.) = \beta(C_o - C_s)$$

where  $\beta$  is the diffusion coefficient and  $C_o$  is the reactant concentration in the bulk gas stream. The reaction rate can be rearranged in terms of  $C_o$

$$(r.r.) = k'C_o$$

where

$$k' = \left( \frac{1}{1/k + 1/\beta} \right)$$

For a system in thermal equilibrium, the heat generated by the reaction is dissipated through heat loss to the surrounding such that

$$k'C_o(\Delta h) = \alpha(T_s - T_o)$$

where  $\alpha$  is the net heat transfer coefficient and  $(T_s - T_o)$  is the temperature difference between the catalyst surface and the oncoming gas. The Arrhenius rate constant,  $k = A \exp(-E/RT_s)$ , is then substituted and an equation as a function of  $T_s$  is obtained.

After some mathematical manipulation an approximate solution for the case of  $E/RT_s \gg 1$  and  $(T_s - T_o) \ll T_o$  is obtained. The critical condition for ignition is assumed to be satisfied when that function attains an extreme value. The final expression can be rearranged as

$$\ln \left[ \frac{(T_{ig} - T_o)^2}{C_o} \right] = \left( -\frac{E}{R} \right) \frac{1}{T_{ig}} + \ln \left( \frac{\Delta h A R T_o^2}{e \alpha} \right)$$

Based on the above relation, an Arrhenius-type plot can be constructed and the associated slope is equal to  $-E/R$ . Thus, the activation energy  $E$  and the pre-exponential factor  $A$  can be determined from such a plot. This theory has since been extended by Schwartz et al. (1970) to reaction of arbitrary order.

The key assumptions applied invoked in the above theories are:

- a) The surface concentration of the reactant is determined uniquely by its gas-phase concentration.
- b) The heat transfer coefficient  $\alpha$ , the reaction order  $n$ , and the pre-exponential factor  $A$  are independent of temperature.
- c) At ignition the energy balance equation for  $k \gg \beta$  is still valid.

The condition for ignition is identified as the point where the heat generation curve meets the heat loss line tangentially, as shown in Fig. 4.1. Accordingly, the derivatives of the two energy terms with respect to  $T$  can be equated at  $T_{ig}$ . The kinetic parameters are obtained by running a series of experiments under different heat transfer conditions and fuel concentrations.

#### 4.2.2 Limitations of the Analysis

The reactions of interest to combustion involve at least two reactants - fuel and oxidizer. In homogeneous reactions, an explicit dependence of the reaction rate on oxidizer can be suppressed by supplying an abundant amount of oxidizer such that its concentration is not changed appreciably during the reaction. The same concept, however,

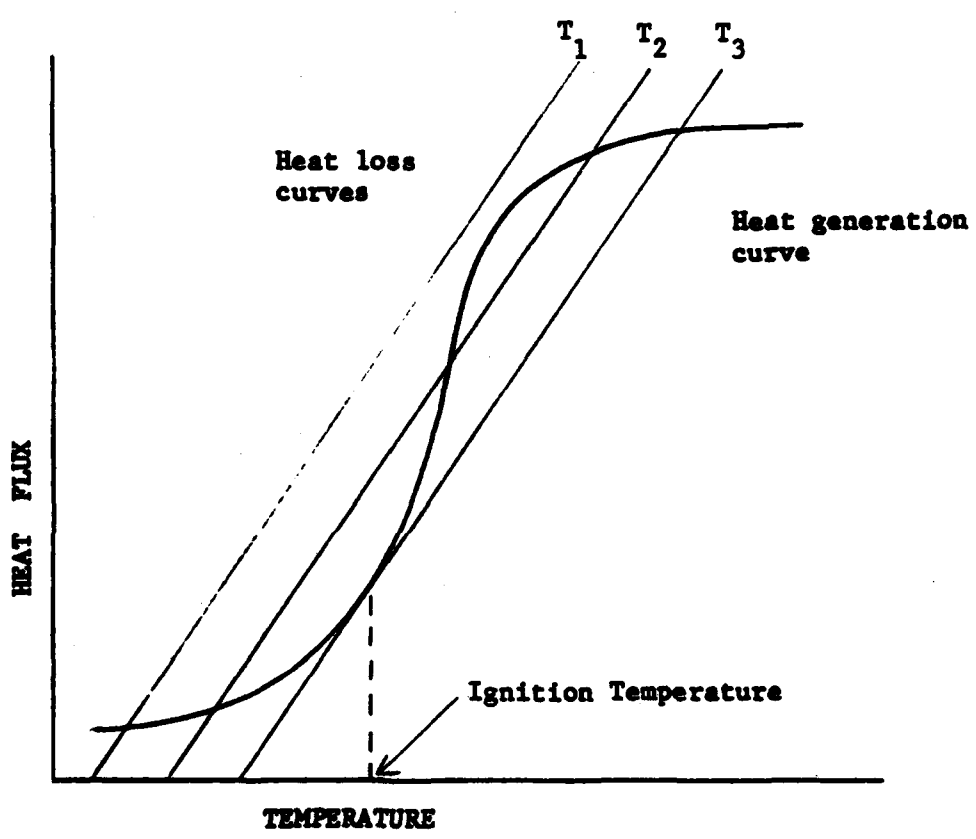

Figure 4.1 Schematic presentation of heat generation due to chemical reaction and heat loss to the surrounding at different catalyst temperatures

cannot be applied to catalytic reactions. Moro-oka and co-workers (1967) have shown that fuel-lean mixtures do not necessarily guarantee a reaction rate that is zero order in oxygen. In fact, the zero-order reaction with respect to oxygen is found to be a rather exceptional case in their study of hydrocarbon oxidation over various catalysts, both metals and metal oxides. For most of the reactions studied, the reaction orders in oxygen and in fuel are comparable. As extreme cases, we note that acetylene oxidation exhibits reaction order in oxygen of 1.37 over platinum, whereas for propane over palladium we have -1.6. The same gas mixtures over  $\text{CaO}_2$  show 0.00 and 0.25 order in oxygen, respectively.

The reason for these variations can be found in the surface phenomena unique to heterogeneous reactions. That is, the interaction with the surface as the third "reactant" cannot be ignored. In the case of hydrogen adsorption on platinum surface, Netzer and Kneringer (1975) found that there is a sharp increase in the hydrogen coverage at about 40°C. The surface coverage at 90°C falls to a mere 10% of the maximum. Engel and Ertl (1979) observed an asymmetric co-adsorption in the case of carbon monoxide oxidation on platinum; pre-adsorbed CO is found to inhibit the adsorption of oxygen, whereas the reverse is not the case. Gentry et al. (1973) have found that hydrogen oxidation over platinum can take place by two different mechanisms depending on the initial treatment of the catalyst. Specifically, they found that the reaction rate is higher for an oxidizing surface than a reducing one. Moreover, a significant dependence of the reaction order on the partial

pressure of the reactant is reported by Kemball and Patterson (1962). For example, in palladium film catalyzed oxidation of ethylene, the reaction rate is found to vary to the first order in fuel at low pressures but zero order at high pressures.

The consensus is that the key assumptions made in the derivation of the thermal theory are generally not valid. Its usefulness is limited to a few exceptional cases and, even when it is applicable, the accuracy of the kinetic parameters obtained from a narrow temperature range are questionable. Furthermore, since the surface concentrations of reactants and the reaction order may depend strongly on temperature, the energy terms cannot be differentiated with respect to  $T$  without a priori knowledge on their functional form. Consequently, numerous investigations have stressed the importance of understanding adsorption in modeling catalytic oxidation reactions (Margolis, 1963, 1973; Sachtler, 1970; Vogue and Adams, 1967) and attempts have been made to correlate the catalytic activity to physical properties of the catalyst.

#### 4.2.3 Classification by Chemisorption Strength

A correlation between heat of adsorption and catalytic activities was found by Beeck (1950). Later, Ponc et al. (1966) suggested the possibility of relating the absolute value of heat of adsorption to the activation energy for transition metals. In particular, Moro-oka and co-workers (1967) have found that for isobutene and acetylene oxidations, the reaction order in hydrocarbon increases with increasing  $\Delta H_o$ , which is the heat of formation of the catalyst oxides divided by

the number of oxygen atoms in the oxide molecule. Since the term  $\Delta H_o$  is a measure of the bond strength between the metal atom and adsorbed oxygen, the correlation is basically between the surface coverage and the nature of the metal-oxygen bond. In particular, they could plot the catalytic reactivities of different metals for a given fuel mixture with  $\Delta H_o$  in the abscissa (Fig. 4.2). This kind of graph would provide important information for the design of catalyst under a given reaction condition.

However, an equally important information can be obtained from a correlation between the catalytic reactivities of a given catalyst under the reacting conditions and the participating reactants. But the phenomena found under the reaction conditions are very complicated because the interaction between the reactants must be considered as well as the interaction between the surface and the individual reactants. A measure of the intensity of interaction between the surface and the individual reactants is the strength of chemisorption and, therefore, its knowledge is essential to the understanding of the whole phenomena.

It is well established that the chemisorption strength generally decreases in the following order:



The variations in the strength of chemisorption is interpreted in terms of molecular orbital theory. For example, the difficulty in chemisorbing saturated hydrocarbons is attributed to the need of rupturing a hydrogen-to-carbon bond before interaction with the surface can take place.

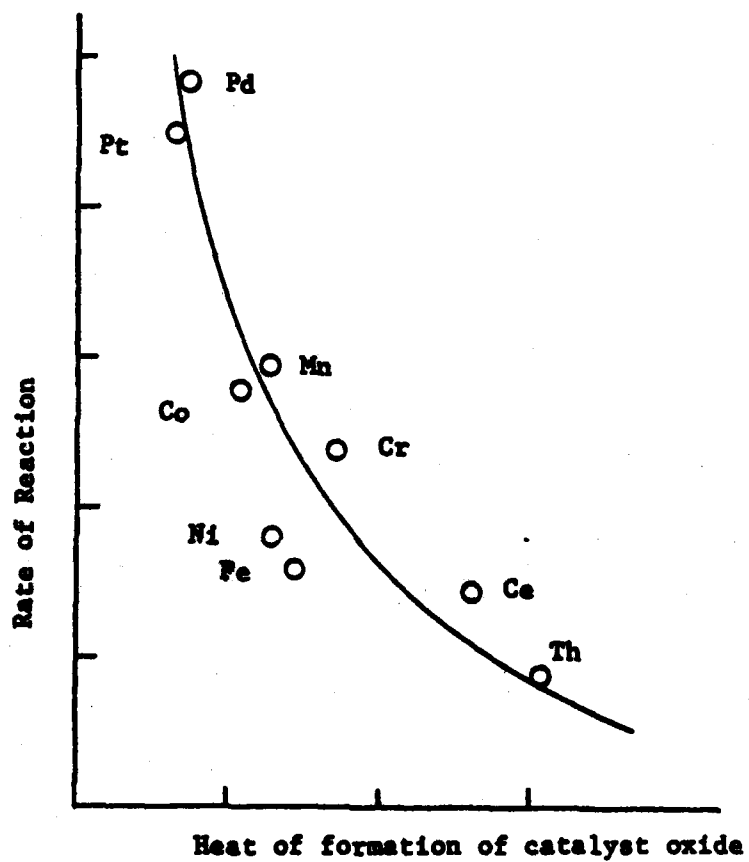
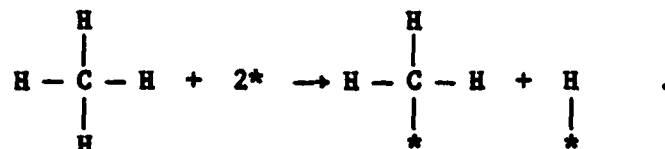

Figure 4.2 Correlation of the catalytic activity with the heat of adsorption

The chemisorption strength varies within the members of a hydrocarbon family because different H-C bonds are broken for different molecules. In the case of methane, chemisorption is preceded by the removal of a hydrogen atom from the primary carbon atom.



But, since the dissociation energy of the primary hydrogen is prohibitively high, methane molecules resist dissociative chemisorption. The difficulty of adsorbing methane on platinum is reflected in the extremely low rate of reaction reported by Frennet (1974).

For propane, the hydrogen atom is abstracted from the secondary carbon atom. The chemisorption process is then

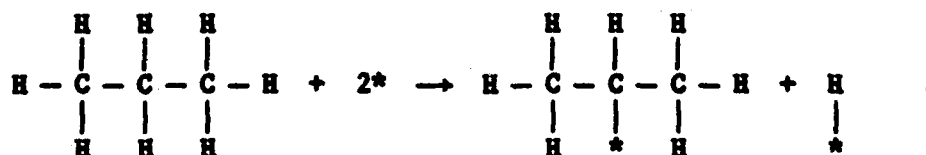

Chemisorption is easier for propane than methane because the dissociation energy of H-C bond for the secondary carbon atom is much less than that for the primary carbon atom.

On the other hand, propylene and ethylene atoms are relatively

easily chemisorbed due to the presence of weak  $\pi$ -bond which, together with a  $\sigma$ -bond, forms the double bond between two carbon atoms. Two different molecule-catalyst complex have been proposed. The first involves rupture of the carbon-carbon  $\pi$ -bond and the subsequent formation of two separate carbon-metal  $\sigma$ -bonds. The resulting structure is

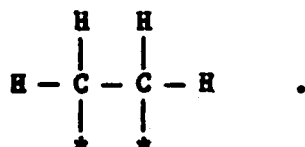

The second, and the more widely accepted, configuration involves no bond breaking

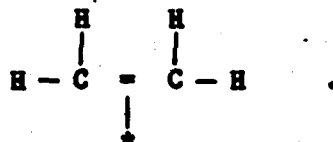

For the higher alkenes, oxidation occurs by removal of a hydrogen atom at the allylic portion. The ease of chemisorption is apparent since the allylic H-C bond is much weaker than any other H-C bond in hydrocarbon molecules

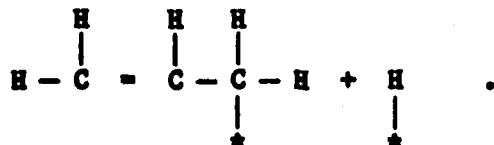

At present the information on chemisorption is only qualitative.

However, much can be learned from the sequence of chemisorption strength in the case of oxidative reactions, especially when the chemisorption strength of oxygen and various fuels are compared. Specifically, two types of chemisorption processes can be identified. The first type is competitive chemisorption that would occur in the oxidative reaction of propylene. Since both oxygen and propylene molecules can be strongly chemisorbed on platinum, they would compete for the same catalytic sites. The competition would be less intense as the difference in the chemisorption strength between oxygen and fuel becomes more appreciable, as in the case of carbon monoxide and hydrogen oxidations. The second type can be found in the oxidative reactions of propane and of butane in which oxygen molecules are preferentially chemisorbed.

The nature of interaction between the reactants during chemisorption can exert a great influence on catalytic ignition of various fuel mixtures because chemisorption is a crucial step that initiates chemical reaction at a solid surface. The results of the present investigation into the ignition temperatures substantiate the validity of classifying the fuel oxidation processes according to the chemisorption strength of fuel relative to that of oxygen.

#### 4.3 IGNITION OF THE PROPANE GROUP

Fuels classified under the propane group are propane and butane which are weakly chemisorbed on platinum surface. Given the fact that the oxygen molecules are readily and strongly adsorbed on the platinum surface, the ignition of propane/air or butane/air is expected to be

critically controlled by the amount of fuel adsorbed on the surface. Since the surface coverage of fuel molecules is related to its partial pressure, ignition is expected to be facilitated by enriching the gas mixture with more fuel.

These concepts are tested by studying ignition trends for propane/air and butane/air mixtures; their results will be discussed first. More detailed result on the effects of fuel and oxygen concentrations will be presented in the subsequent sections.

#### 4.3.1 Effect of Fuel Concentration

Figure 4.3 shows the effect of fuel concentration on the ignition temperatures of propane/air mixtures. It shows that the ignition temperature decreases monotonically with increase in the fuel concentration.

Similar trend is observed for butane/air mixtures (Fig. 4.4). The reduction in the ignition temperature for butane/air is  $75^{\circ}\text{C}$  over the fuel concentration range of 0.5 to 1.5%. This is almost  $15^{\circ}\text{C}$  more than that obtained for propane/air mixtures over a comparable range of fuel concentration. However, the sharper decrease observed for butane/air is annulled when relative fuel concentrations instead of the actual amounts are considered, as demonstrated next.

Figure 4.5 shows the same data points plotted as a function of equivalence ratio which is a measure of the amount of fuel in the mixture relative to the stoichiometrically correct amount. The result indicates that the ignition temperature for both propane/air and

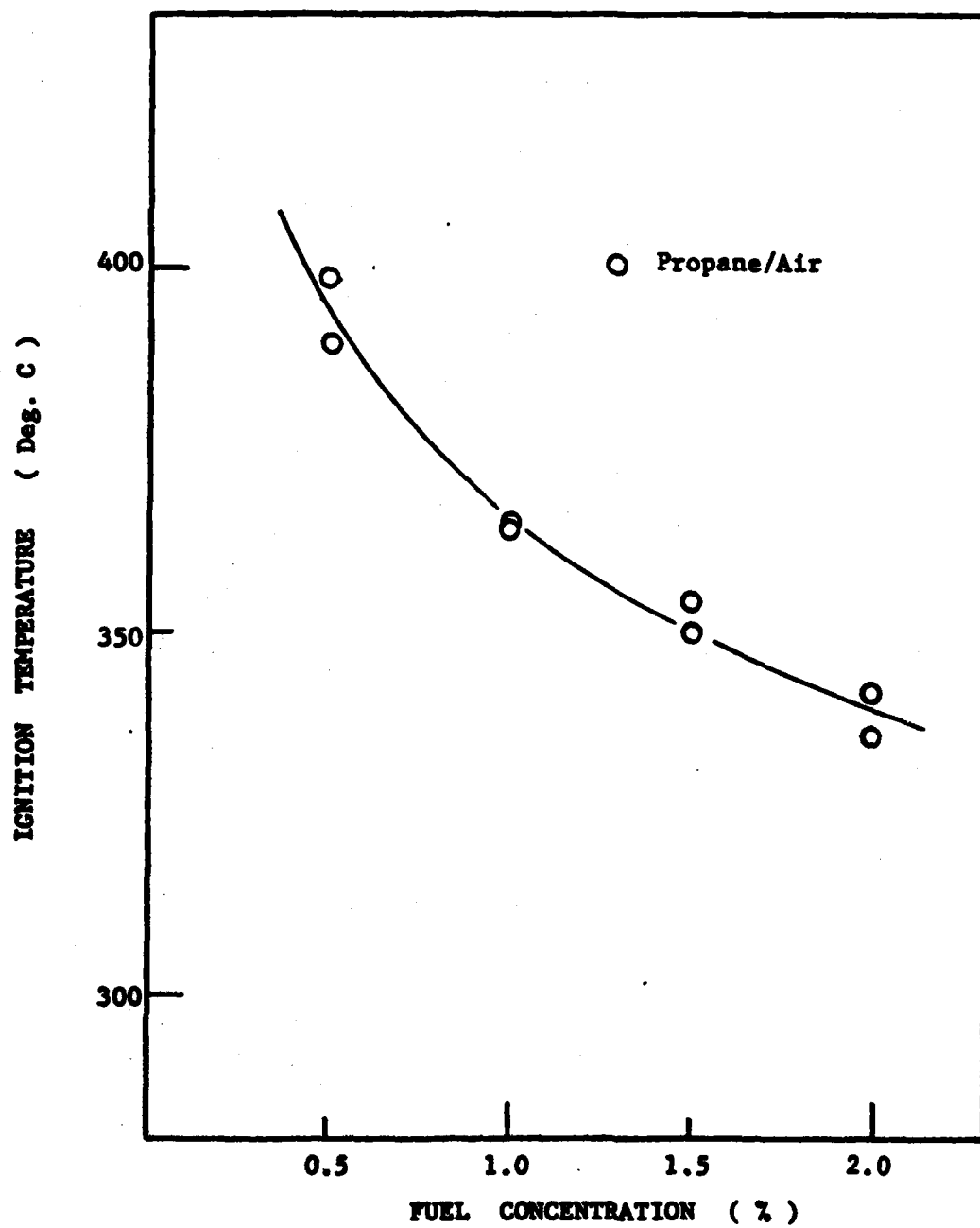

Figure 4.3 Effect of fuel concentration on the ignition temperature of propane/air mixtures

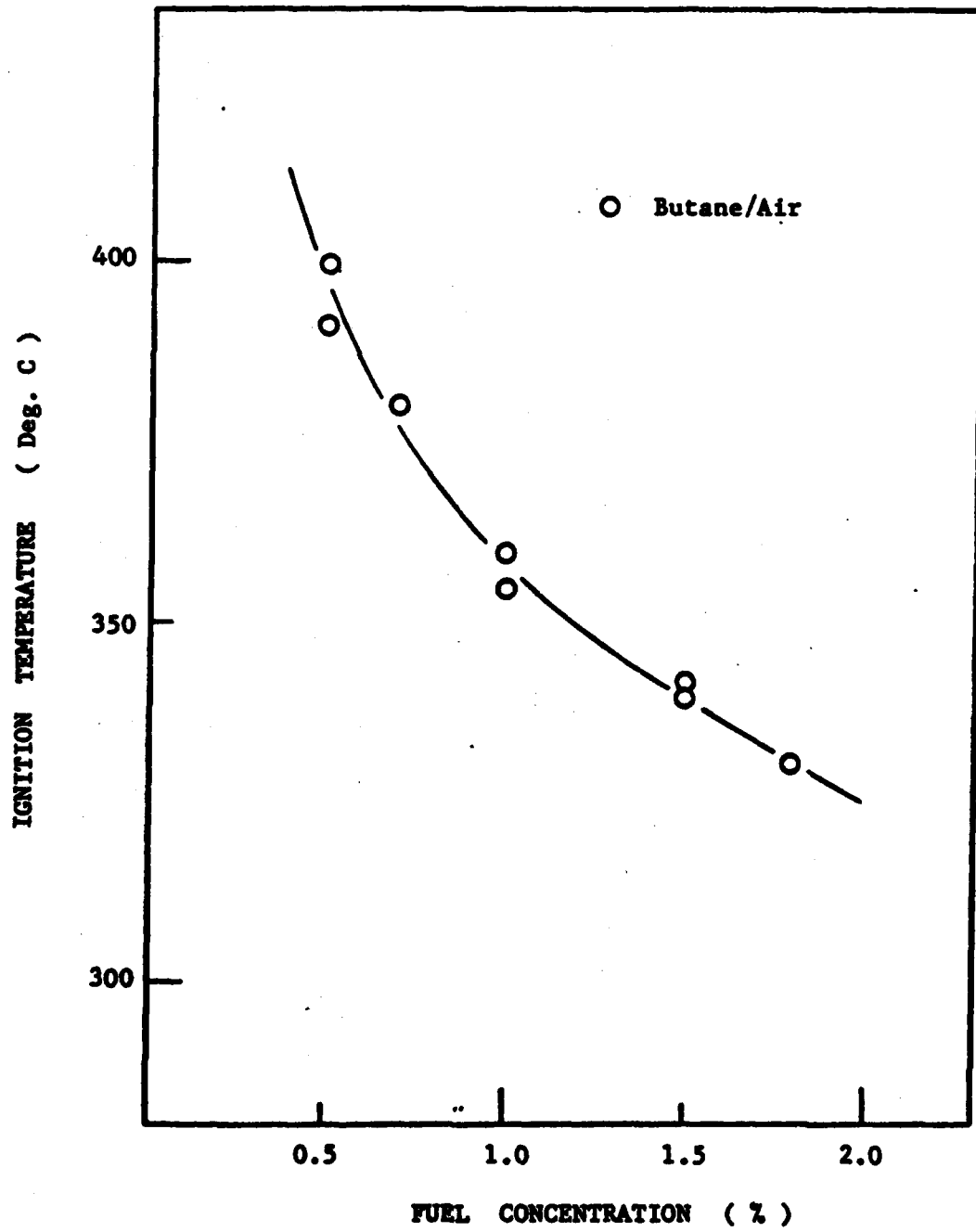
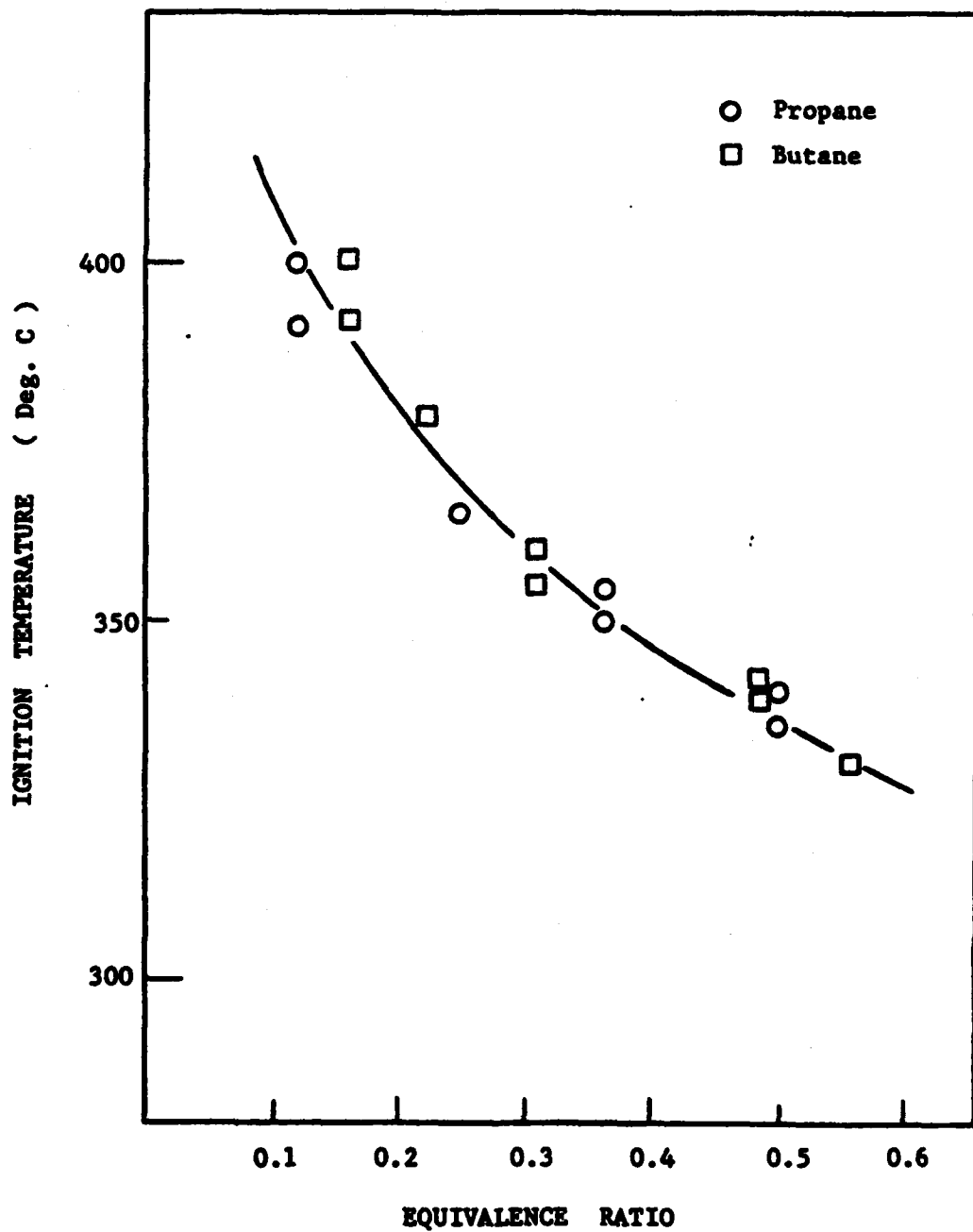

Figure 4.4 Effect of fuel concentration on the ignition temperature of butane/air mixtures



**Figure 4.5** Effect of fuel concentration on the ignition temperature of propane/air and butane/air mixtures: A comparison based on the equivalence ratio

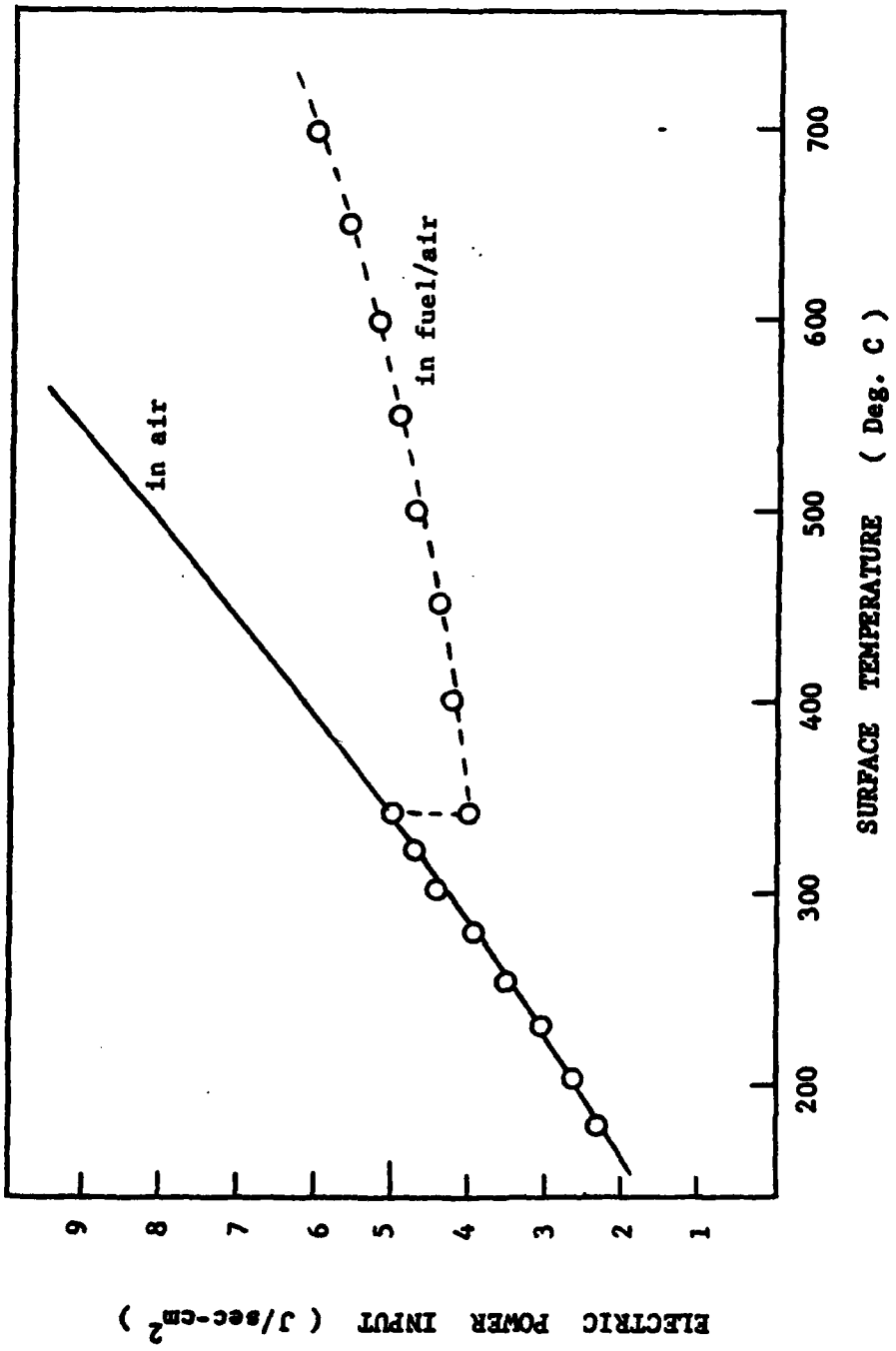

Figure 4.6 Electrical power input to the catalytic wire for propane/air mixture with 2% propane by volume

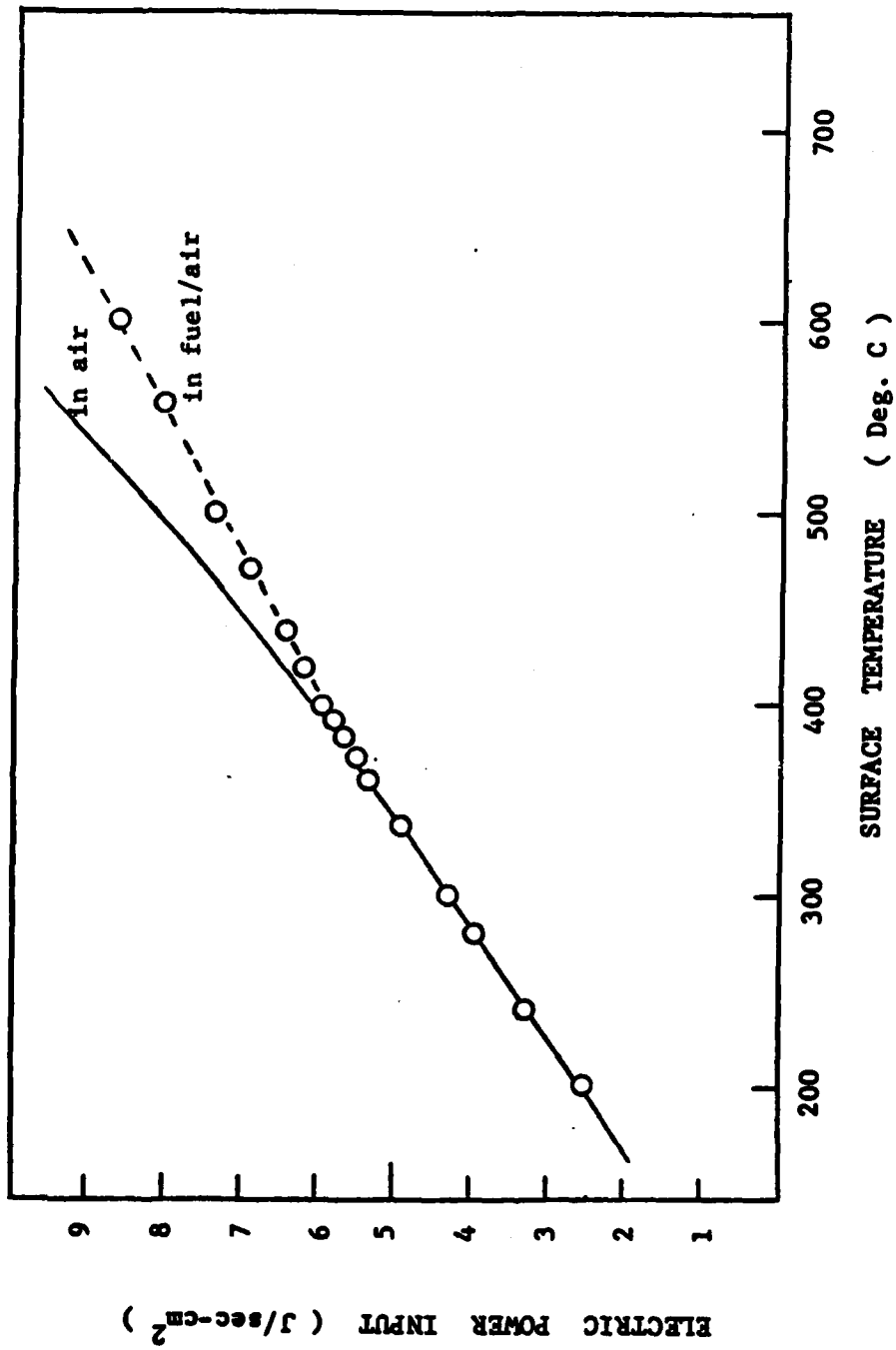

Figure 4.7 Electrical power input to the catalytic wire for propane/air mixture with 0.5% propane by volume

butane/air can be plotted on a single curve. This result is quite reasonable because the energetics of propane and butane oxidations over platinum surface are quite similar. For example, during the chemisorption process of both propane and butane it is the secondary hydrogen that is dissociated. Therefore, the same amount of thermal energy is required to initiate the chemisorption process which is the prerequisite step for surface reactions.

The small scatter at low equivalence ratios is due to the difficulty in pinpointing the ignition for the mixtures with low fuel concentrations. Figures 6 and 7 show some new data illustrating the difference in the ignition behavior of propane/air mixtures. For a propane concentration of 2.0%, an abrupt change in the power consumption clearly marks the point of ignition. In contrast, a steady change in power consumption for the mixture with 0.5% propane makes the point of transition less obvious.

#### 4.3.2 The Propane/Oxygen/Nitrogen Mixtures

The decreasing trend of the ignition temperature can be misleading when it is observed over a narrow range of fuel concentrations. Since the ignition temperature decreases at decreasing rate, it is reasonable to expect that there may exist a minimum ignition temperature below which no ignition is possible. However, the experimental investigation cannot be extended out beyond 2% fuel concentration to verify the leveling of the ignition temperature because the fuel/air mixture is then capable of gas-phase ignition. The lower limit of flammability for

propane in air is only slightly higher than 2% and this imposes a practical ceiling to the fuel/air mixture that can be safely tested.

The need to extend the range of study from lean to rich cases and, at the same time, to suppress gas-phase ignition can be accomplished by diluting the fuel/air mixture with nitrogen. Figure 4.8 shows the concentration map of propane/oxygen/nitrogen mixtures tested. The fuel and oxygen (from air) concentrations are given. The concentration of nitrogen is the balance needed to maintain the total flow rate constant. Twenty-four gas mixtures selected for testing represents a network of constant oxygen concentrations, constant fuel concentrations, and constant equivalence ratios.

Figures 9 and 10 show the ignition temperature of all mixtures tested, plotted for constant oxygen concentrations and equivalent ratios respectively. It demonstrates that the ignition temperature of propane/oxygen/nitrogen mixtures are strongly dependent on fuel but not oxygen concentrations. It also shows that the ignition temperature indeed reaches a minimum value and that the leveling off occurs at a high fuel concentration. Figure 4.11 shows that the ignition temperature continues to decrease as the concentration of fuel is increased, although the mixture becomes richer than stoichiometric in the process.

When the two graphs are compared it is apparent that the ignition of propane is controlled by the absolute amount of fuel and not by the amount of fuel relative to the amount of oxygen. This point can be elucidated by considering two mixtures:  $2.5\%C_3H_8/10\%O_2/87.5\%N_2$  and

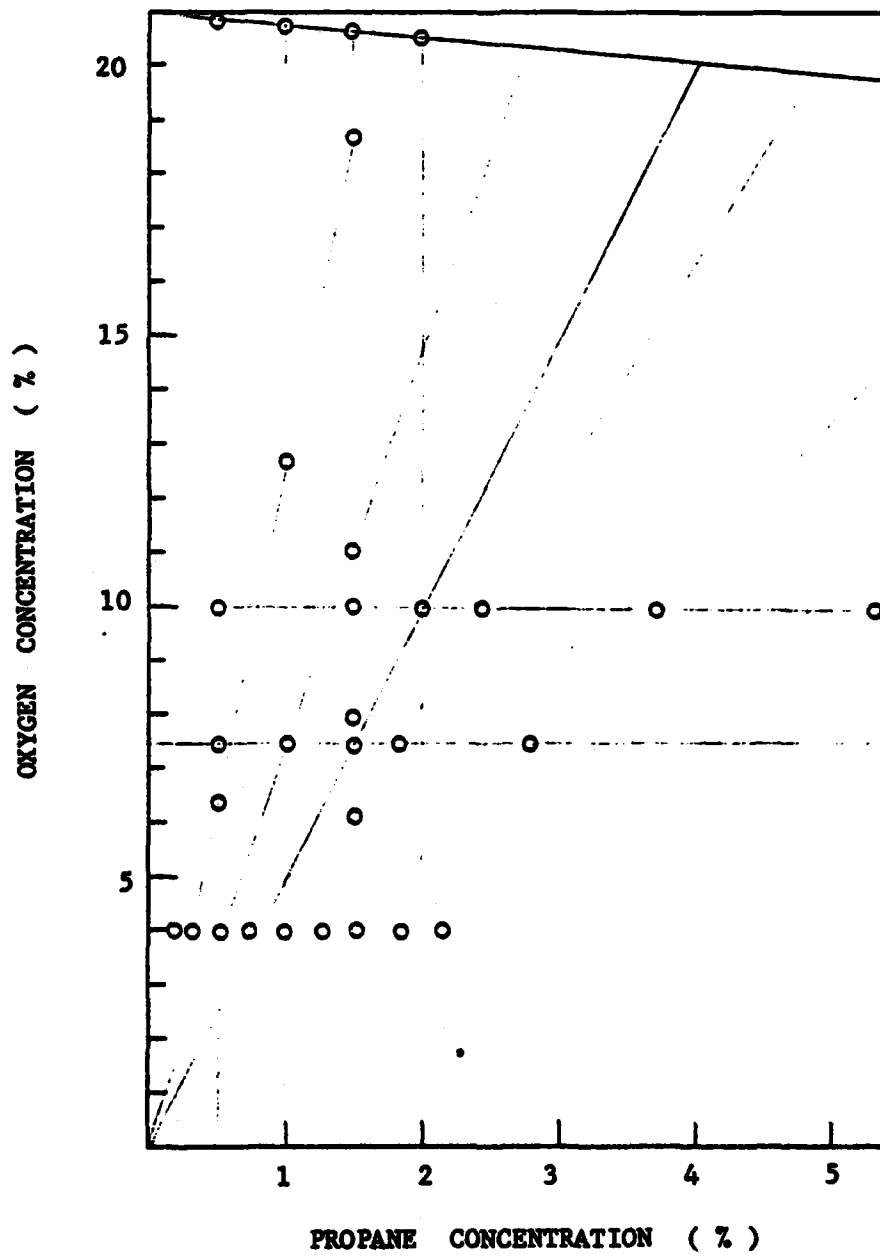

Figure 4.8 Concentration map of propane/oxygen/nitrogen mixtures

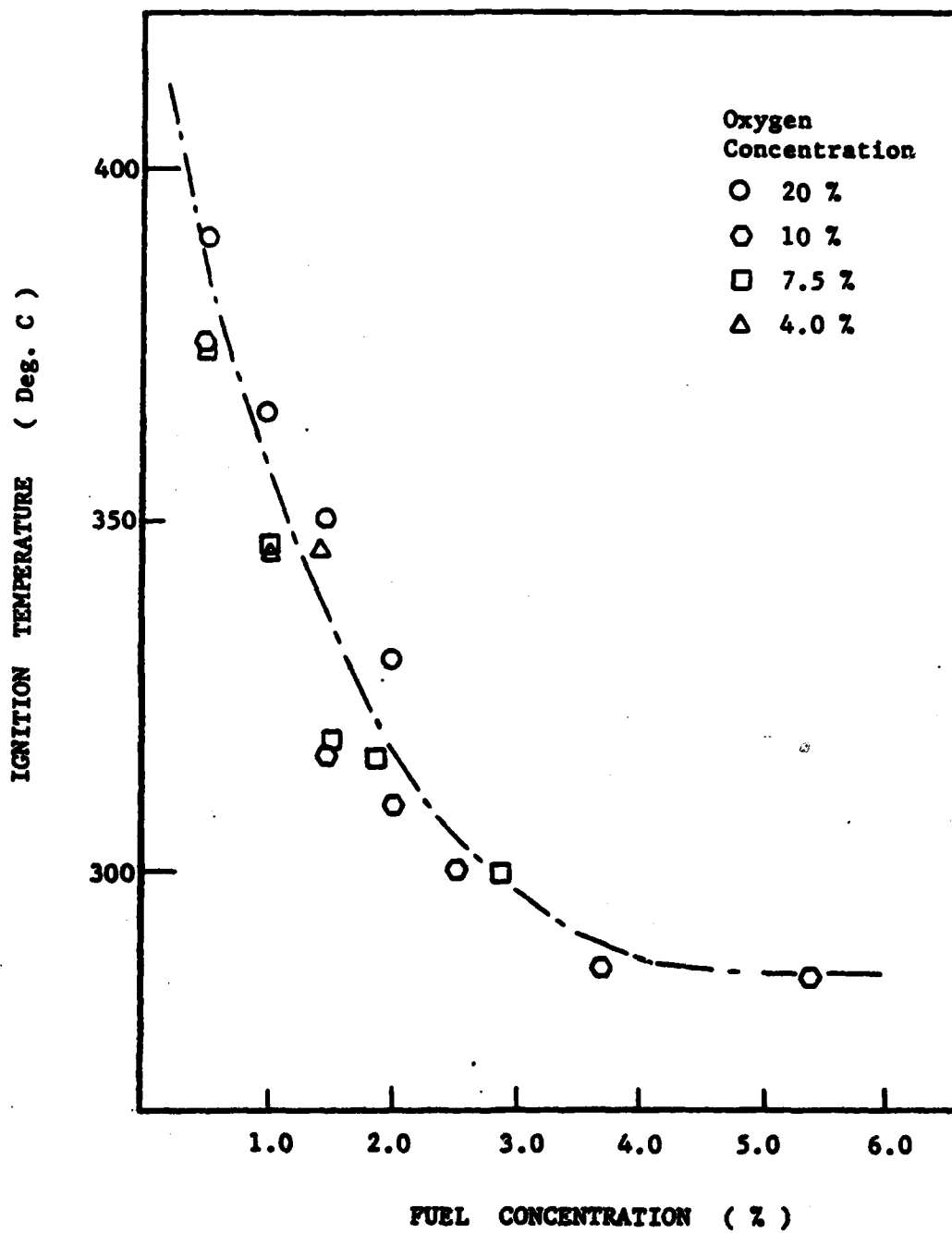

Figure 4.9 Ignition temperatures of propane/oxygen/nitrogen mixtures at constant oxygen concentrations

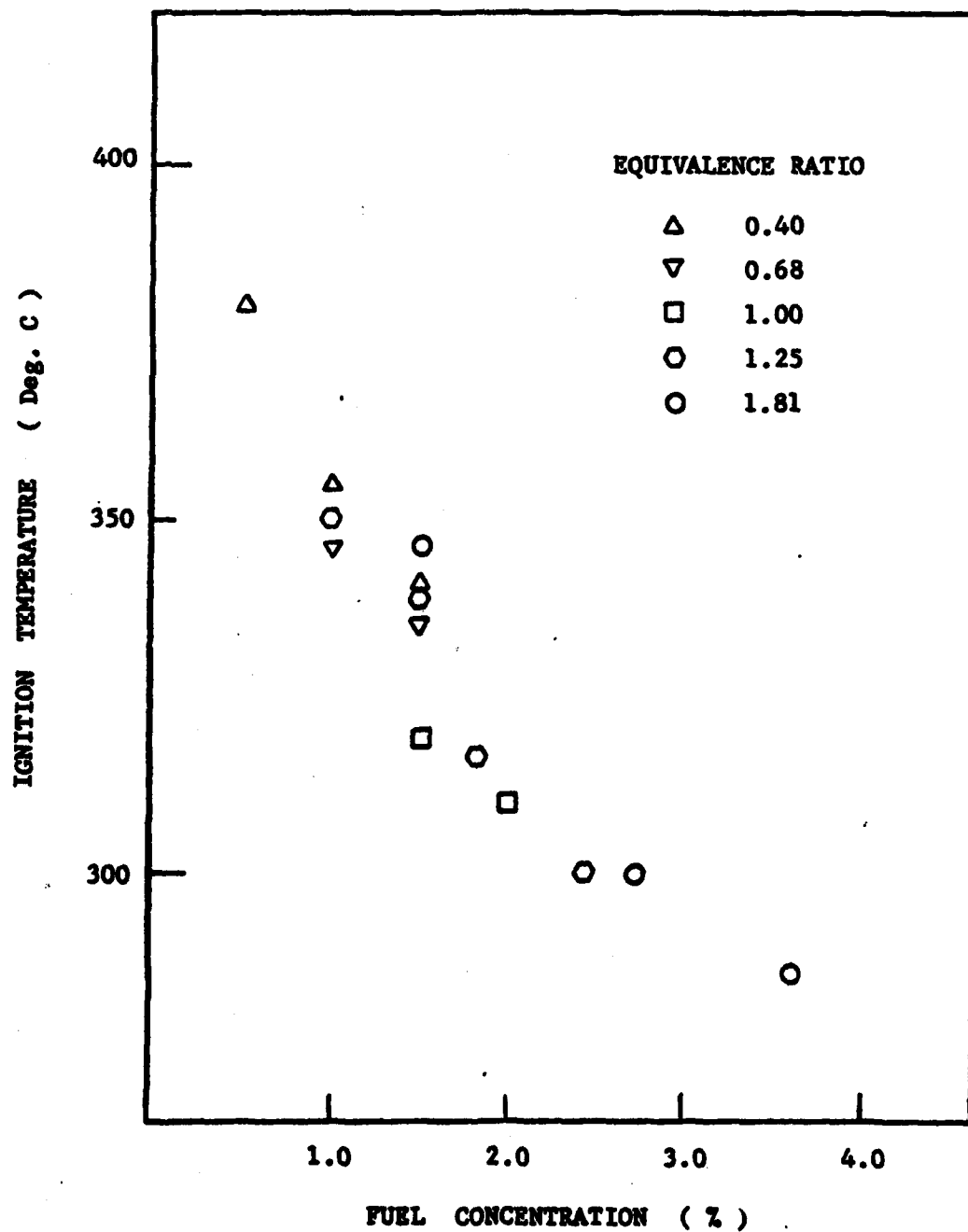

Figure 4.10 Ignition temperature of propane/oxygen/nitrogen mixtures at constant equivalence ratio

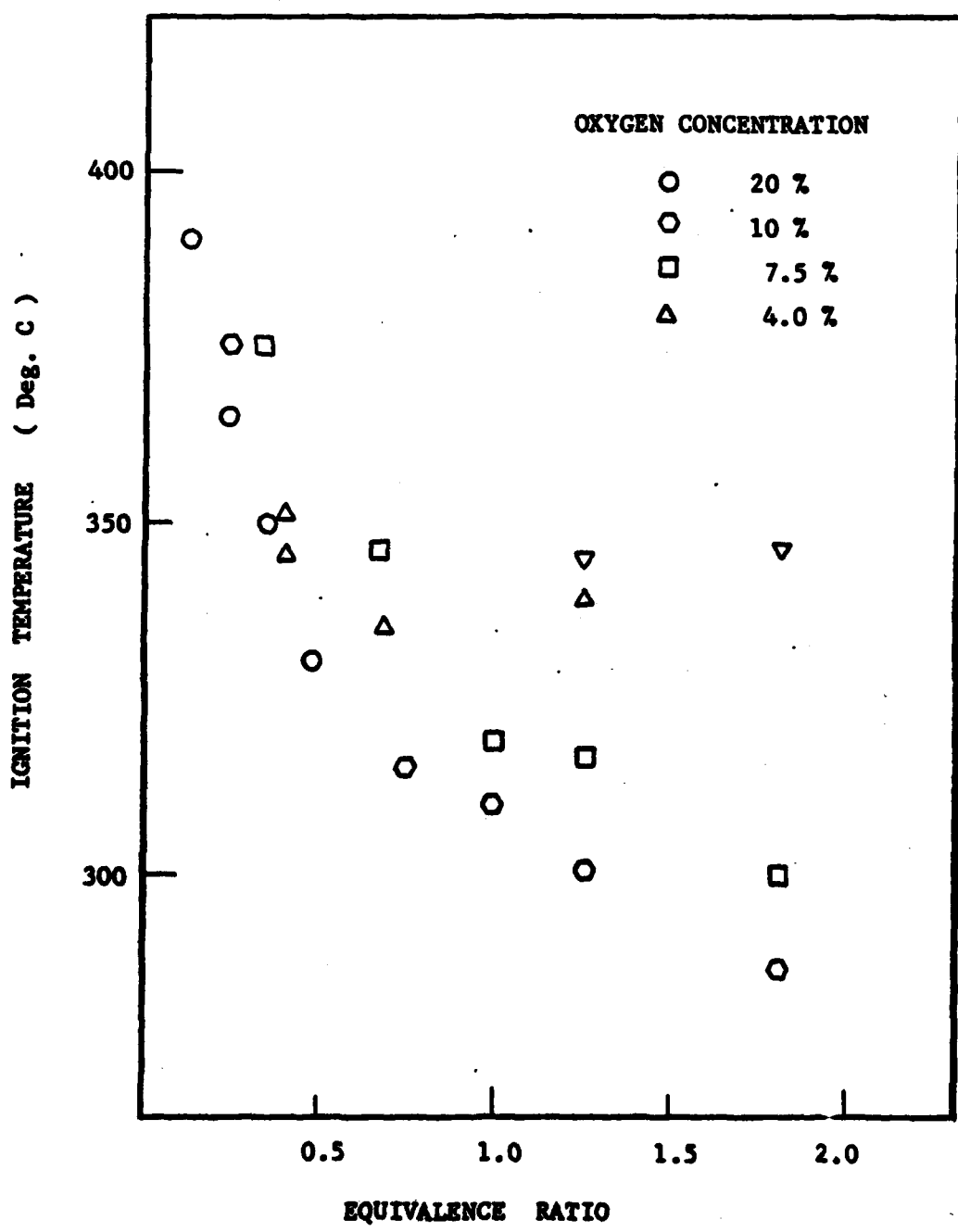

Figure 4.11 Ignition temperature of propane/oxygen/nitrogen mixtures at constant oxygen concentrations: Plot based on the equivalence ratio

1.0% $C_3H_8$ /4% $O_2$ /95% $N_2$ . Both mixtures contain the same amount of propane relative to oxygen, but their ignition temperatures differ by 45°C. This is a large difference considering the fact the full range of ignition temperature of the mixtures tested are only about 100°C.

#### 4.3.3 Effect of Oxygen Concentration

We have demonstrated the the role of fuel concentration as a major factor influencing the ignition temperature. It is also shown that the equivalence ratio is not an important parameter. This result, however, does not imply that the effect of oxygen concentration is negligible and, therefore, insignificant. On the contrary, the ignition temperature can be quite critical of the oxygen concentration and its full effect can be properly gauged only if the effect of fuel concentration is suppressed or properly accounted for.

Figure 4.12 shows the effect of oxygen concentration on the ignition of propane/oxygen/nitrogen mixtures: All mixtures have a constant propane concentration of 1.5%. The plot displays a rather sharp dip in the ignition temperature for a mixture that is slightly rich in oxygen. The reason for the ignition temperature not changing appreciably over much of the oxygen concentration can be explained on the basis of preferential chemisorption. However, why there should be a decrease of the ignition temperature for near-stoichiometric mixtures is not clear.

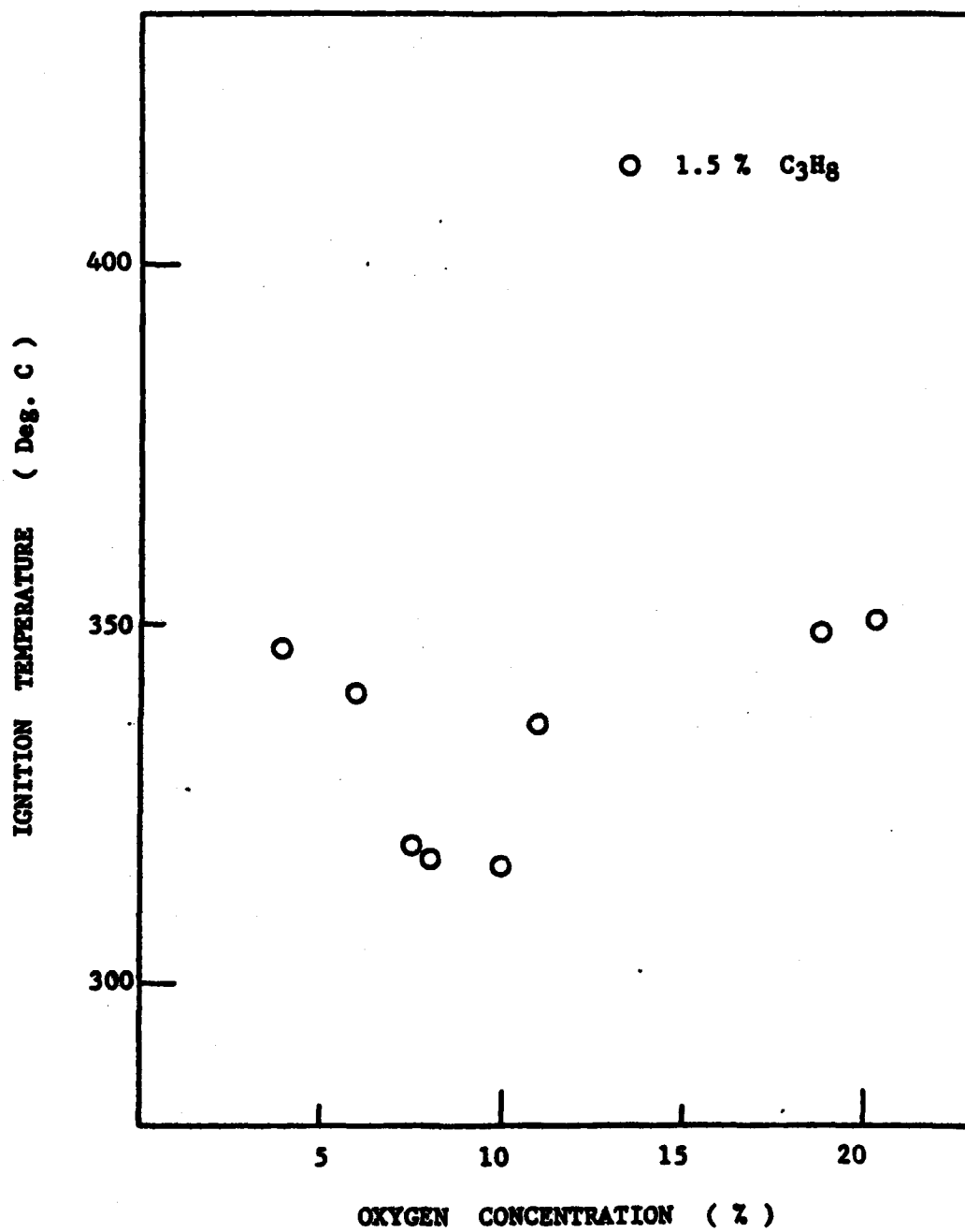

Figure 4.12 Ignition temperature of propane/oxygen/nitrogen mixtures at constant fuel concentration

#### 4.4 IGNITION OF THE PROPYLENE GROUP

Fuels classified under the propylene group are the gases that show substantial chemisorption strength. They are propylene, ethylene, carbon monoxide and hydrogen, in the order of decreasing chemisorption strength. Since propylene and ethylene are comparable to oxygen in their chemisorption strengths, the effect of fuel concentration on ignition will be most pronounced in propylene/air and ethylene/air mixtures. Progressively diminishing influence of fuel concentration on ignition is expected for carbon monoxide/air and hydrogen/air mixtures.

The results will be presented in four parts. In the first part, the general behavior common to all fuel/air mixtures in the propylene group will be discussed; the reason for the characteristic behavior will be explained with hydrogen oxidation as an example. Then, comparison between the ignition behavior of propylene/air and ethylene/air mixtures will be made. Comparison among all fuel/air mixtures are not possible since they belong to different functional groups. A more detailed study with carbon monoxide/oxygen/nitrogen mixtures will be presented in the third part. Finally, the effect of oxygen concentration will be presented.

##### 4.4.1 Effect of Fuel Concentration

Figures 4.13-4.16 show the effect of fuel concentration on the catalytic ignition of fuel/air mixtures. The most striking feature is that in all four cases the ignition temperature increases with increasing fuel concentration. That is, ignition becomes more difficult

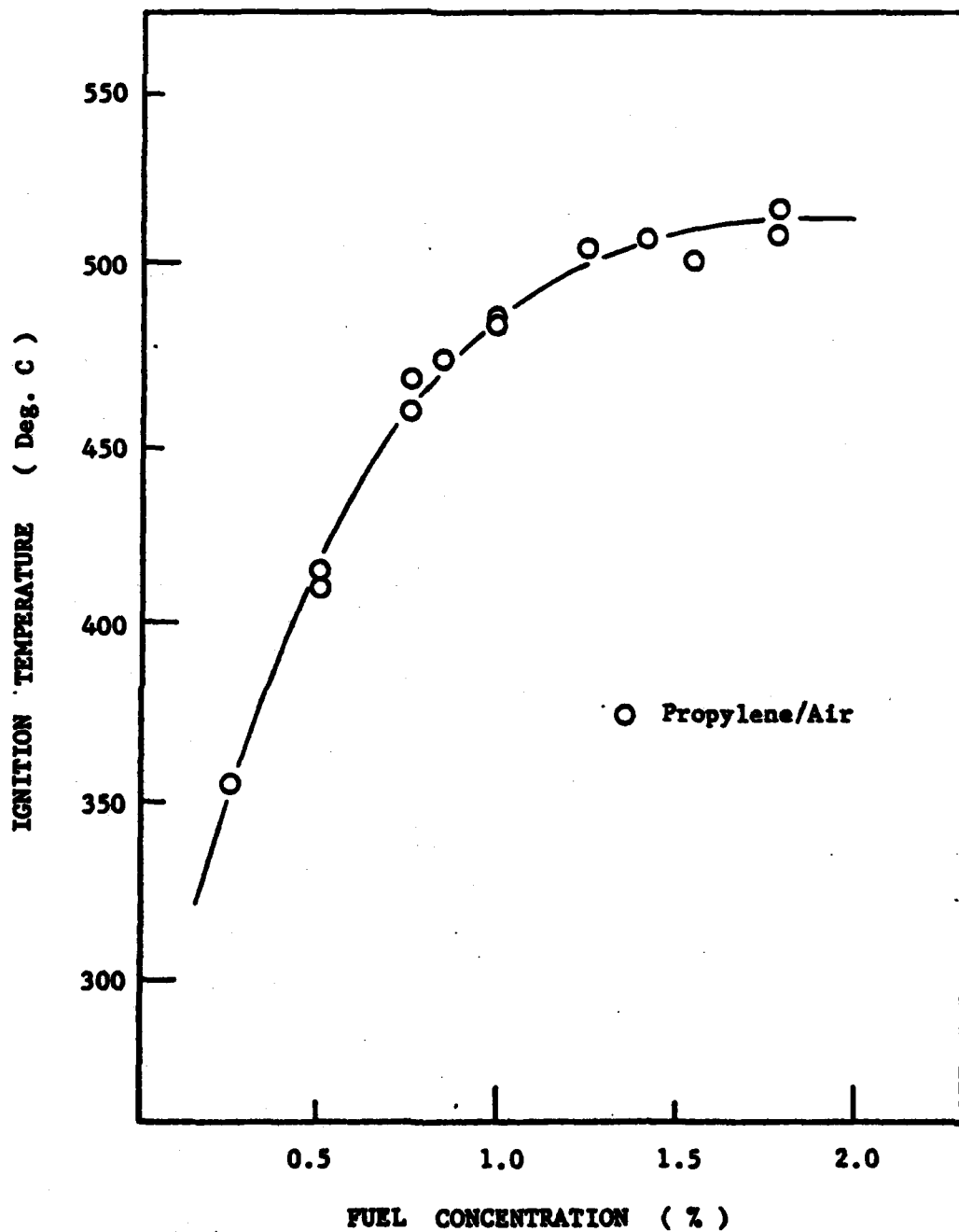

Figure 4.13 Effect of fuel concentration on the ignition temperature of propylene/air mixtures

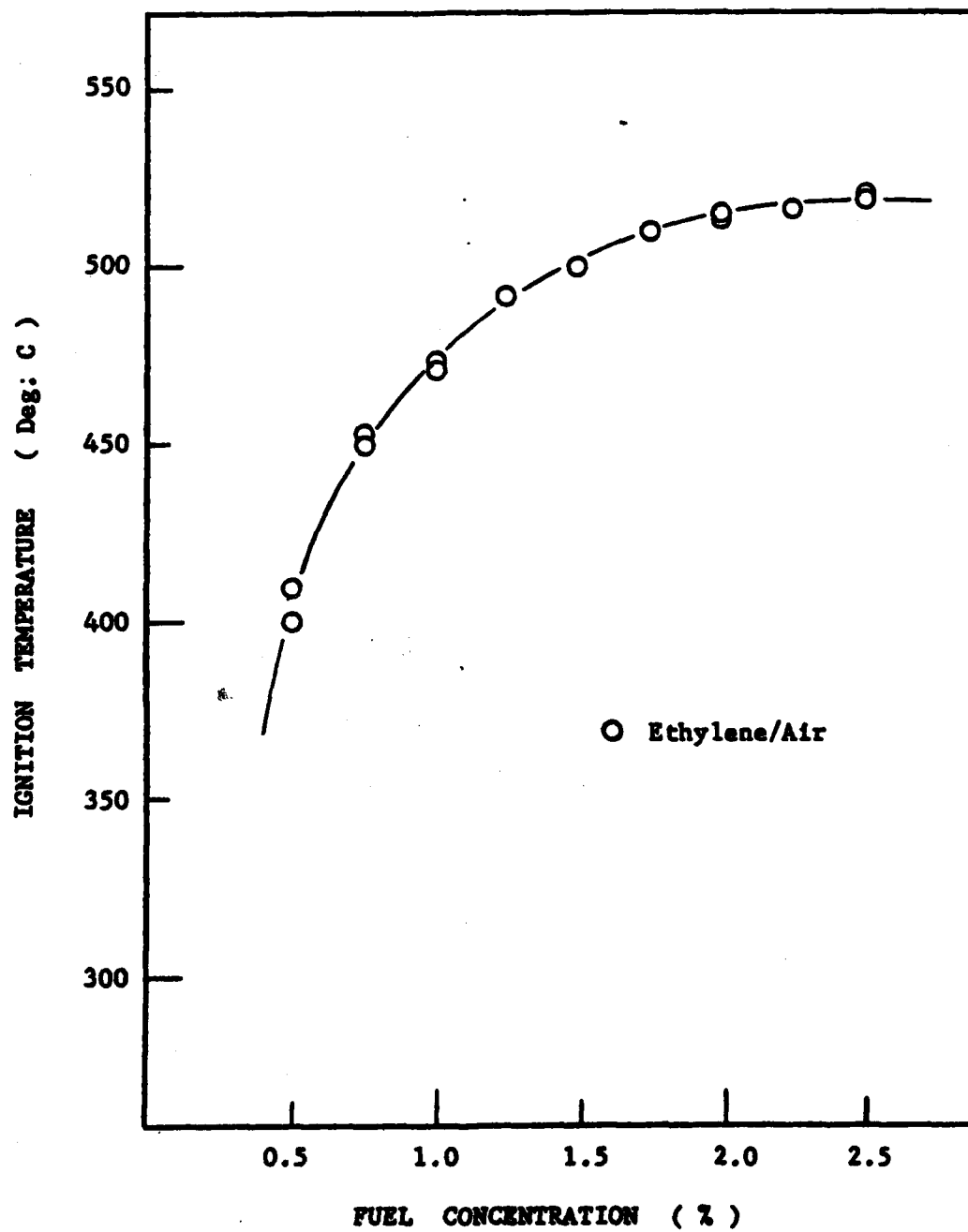

Figure 4.14 Effect of fuel concentration on the ignition temperature of ethylene/air mixtures

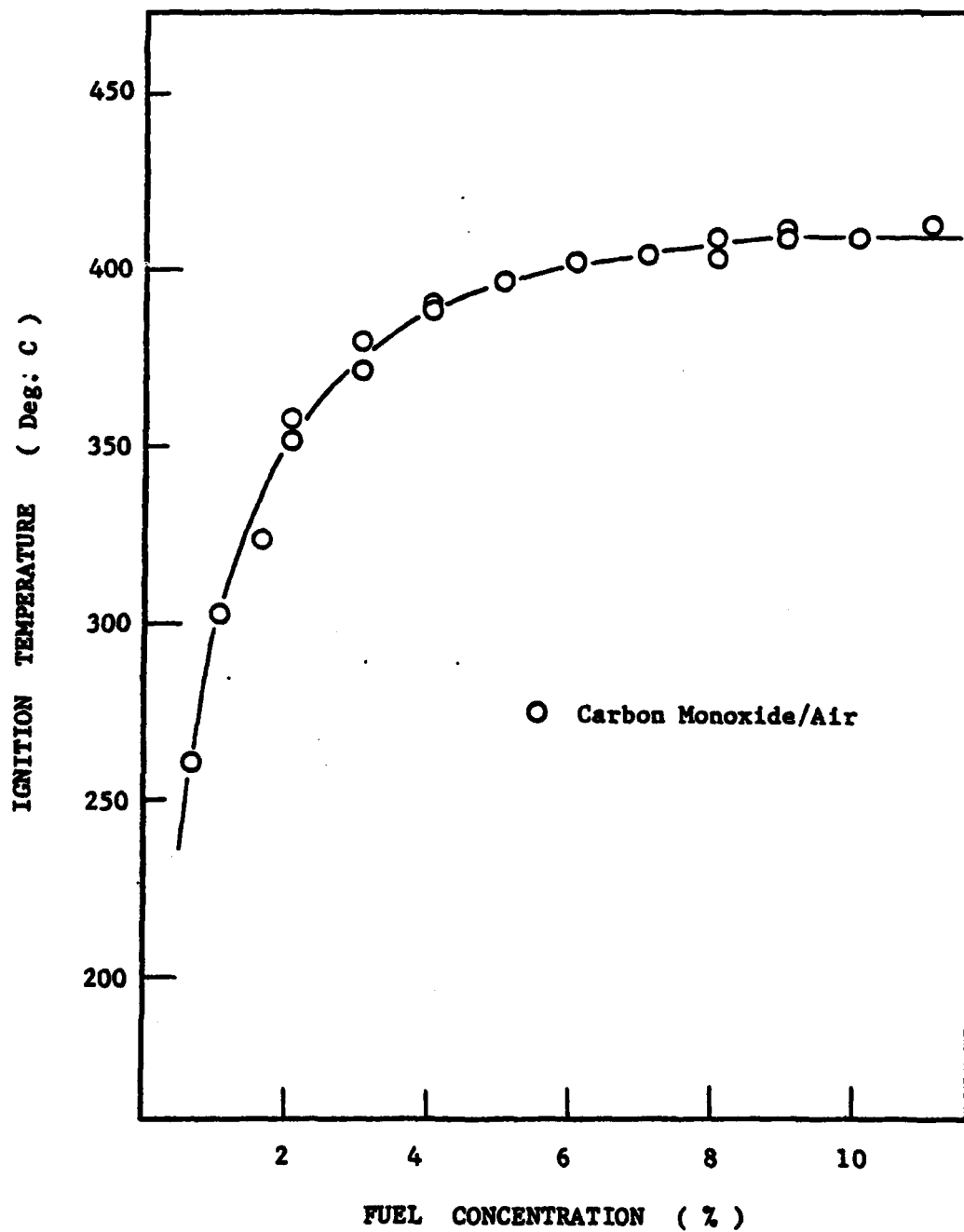

Figure 4.15 Effect of fuel concentration on the ignition temperature of carbon monoxide/air mixtures

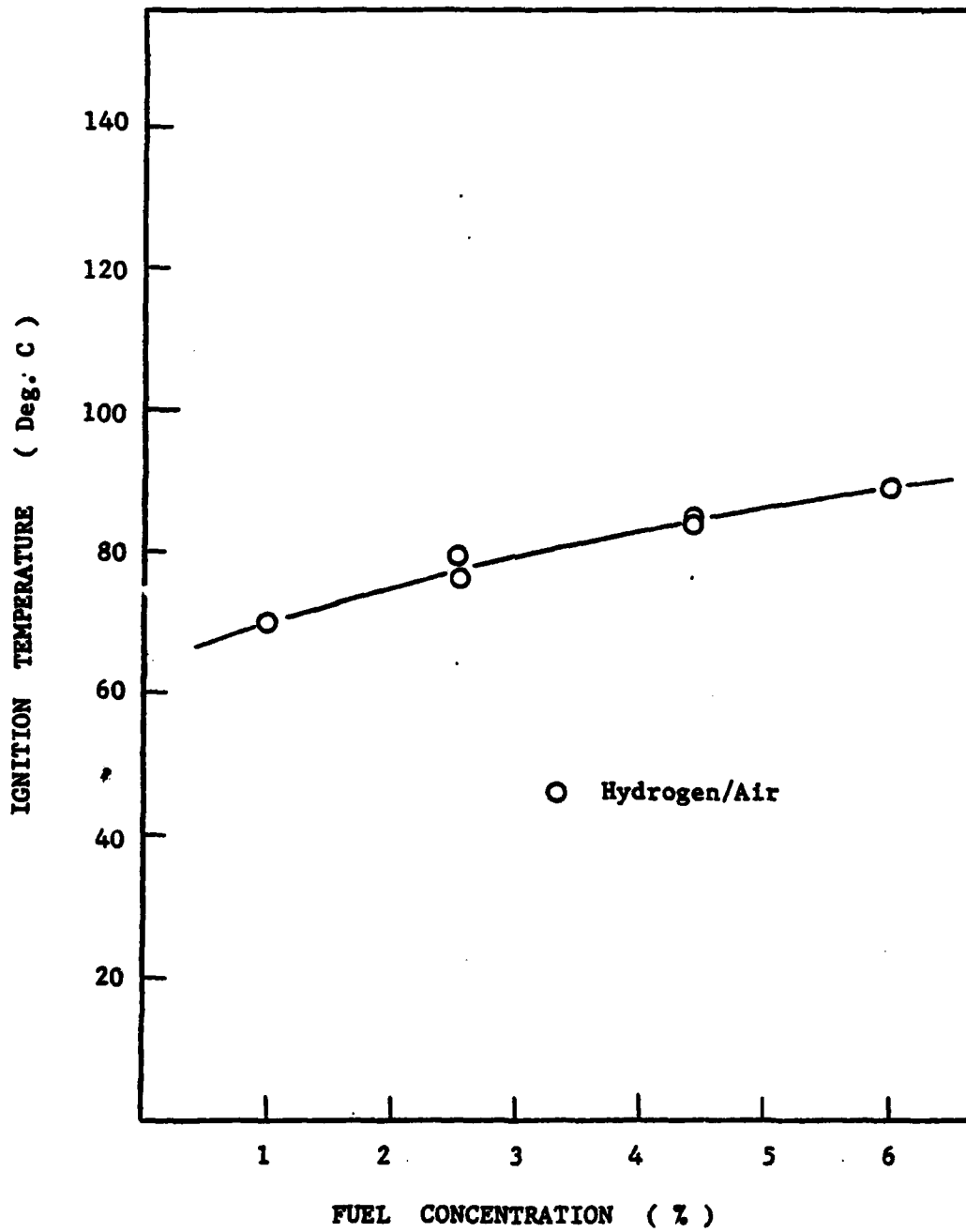
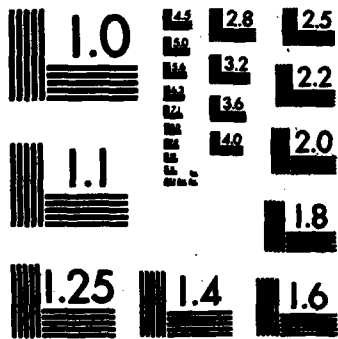

Figure 4.16 Effect of fuel concentration on the ignition temperature of hydrogen/air mixtures





MICROCOPY RESOLUTION TEST CHART  
NATIONAL BUREAU OF STANDARDS-1963-A

by making the mixture richer in fuel. This trend is directly opposite to the catalytic ignition behavior of propane/air mixtures and to the intuition based on the experience with homogeneous systems.

That is, in gas-phase reactions one would normally expect ignition to become progressively easier as a lean mixture is made richer in its fuel concentration. The opposite behavior observed here, in fact, can be compared to a gas-phase ignition of a rich mixture whose ignitability is facilitated by decreasing the amount of fuel in the mixture.

If the importance of having an optimum amount of fuel and oxidizer in the gas-phase reaction can be applied equally to the surface reactions, then the trend of increased temperature with an increase in fuel amount implies that the surface concentration of fuel at the temperature below ignition is always higher than the optimum level for ignition, irrespective of its gas-phase concentration.\* The reasoning is as follows.

Assume that the catalytic surface is initially at a temperature which would provide the optimum level of reactant populations at the surface for given gas-phase concentrations. Let the optimum level be disturbed by increasing the gas-phase fuel concentration. Since the surface coverage of a reactant is related to its gas-phase concentration, the fuel population at the surface would accordingly

---

\*This statement needs to be qualified because the observation on ignition temperature is at present limited to lean fuel/air mixtures only. The rich mixtures at very low oxygen concentration show some deviation from the general trend and, as such, will be separately discussed in a later section.

increase. Then, in order to maintain the optimum level the surface must provide a condition favorable for desorption of fuel molecules. This can be achieved by increasing the surface temperature if selective desorption of fuel molecule takes place such that the oxygen population is not disturbed in the process.

The concept of achieving an optimum level of fuel and oxygen concentration at the catalytic surface for ignition can be best illustrated from the example of hydrogen or carbon monoxide oxidation because they are the two most studied molecules in the field of catalysis. Much information can be gleaned from the well-characterized data on the chemisorption processes of these gases. Netzer and Kneringer (1975), for example, have used the flash desorption mass spectrometry to study the adsorption and reaction of hydrogen with oxygen on platinum surface. In their study they have identified three temperature ranges according to whether one, or both, or none of the reactants are adsorbed on the surface. The region of relevance to ignition is the first one at the lowest temperature range where both reactants are adsorbed but where the variations in the extent of surface coverage by the reactants are significant. Within this range the hydrogen population is observed to decrease very sharply while, over the same temperature range of 40 to 100°C, the oxygen population remains virtually constant.

This kind of sharp depopulation is also observed for carbon monoxide (Engel and Ertl, 1979). Hence, the increase in the surface temperature can be seen as a compensatory effort in an attempt to annul

the effect of increased fuel concentration and thereby maintain the optimum level of adsorption for catalytic ignition.

Another explanation for the difference in the ignition trends between the propane and propylene groups is possible when the concept of preferential versus competitive adsorption is extended one step further. That is, for the oxidation of fuels in the propane group, oxygen can be preferentially adsorbed to the exclusion of fuel molecules. The ensuing reaction would then be between the adsorbed oxygen and the gas-phase fuel molecules (Eley-Rideal mechanism) or between the platinum oxide-like complex and the gas-phase fuel molecules.

#### 4.4.2 Comparison Between Propylene/Air and Ethylene/Air Mixtures

The role of relative chemisorption strength as a dominant factor in the ignition process can be gauged when changes in the ignition temperatures of one fuel/air mixture is compared to another. Generally, sharper temperature changes are obtained for the gases that are strongly chemisorbed, such as propylene and ethylene. Temperature change of as much as 105°C is observed as the ethylene concentration is varied from 0.5 to 2.5%, while only 20°C change is obtained for the entire range of hydrogen concentration (5%).

As mentioned before, the actual amount of fuel is not a fair criterion when the influence of fuel concentration of one gas is compared to that of another. A comparison based on equivalence ratios would be more meaningful. However, the comparison should be between the

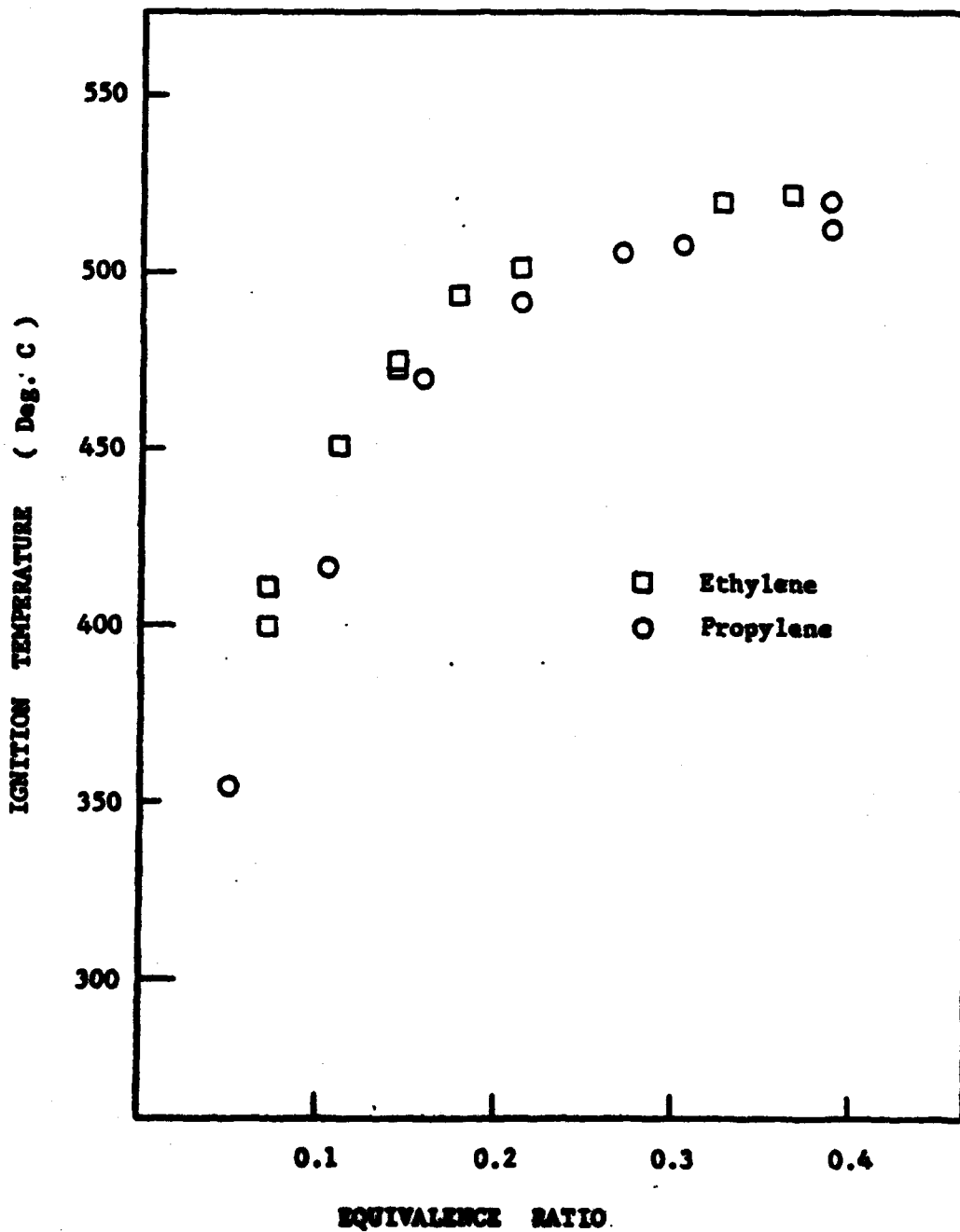

Figure 4.17 Effect of fuel concentration on the ignition temperature of propylene/air and ethylene/air mixtures: A comparison based on the equivalence ratio

gases belonging to the same functional group.

Figure 4.17 shows that propylene/air and ethylene/air mixtures are subjected to a parallel change in the ignition temperature. No exact overlap is obtained as is the comparison between propane and butane. Ethylene/air mixtures consistently ignite at slightly higher temperatures than propylene/air mixtures. The difference may be due to the fact that propylene, having a hydrogen atom in the allyl position, can be dissociatively chemisorbed relatively easier than ethylene.

#### 4.4.3 The Fuel/Oxygen/Nitrogen Mixtures

The second feature that is common to the gas mixtures in the propylene group is the leveling of the ignition temperature to a constant value as the fuel concentration is increased. However, the ignition behavior studied over a wide range of carbon monoxide concentrations, covering the fuel rich as well as the fuel lean mixtures, shows that the relationship is not quite monotonic. Figure 4.19 shows the dependence of ignition temperature on fuel concentration for different oxygen concentrations.

Generally, the variation in the ignition temperature is most rapid within the first 2% fuel concentration. After this the ignition temperature of the mixtures are not influenced by the amount of fuel in the flow.

#### 4.4.4 Effect of Oxygen Concentration

Figure 4.20 shows the effect of oxygen concentration on the

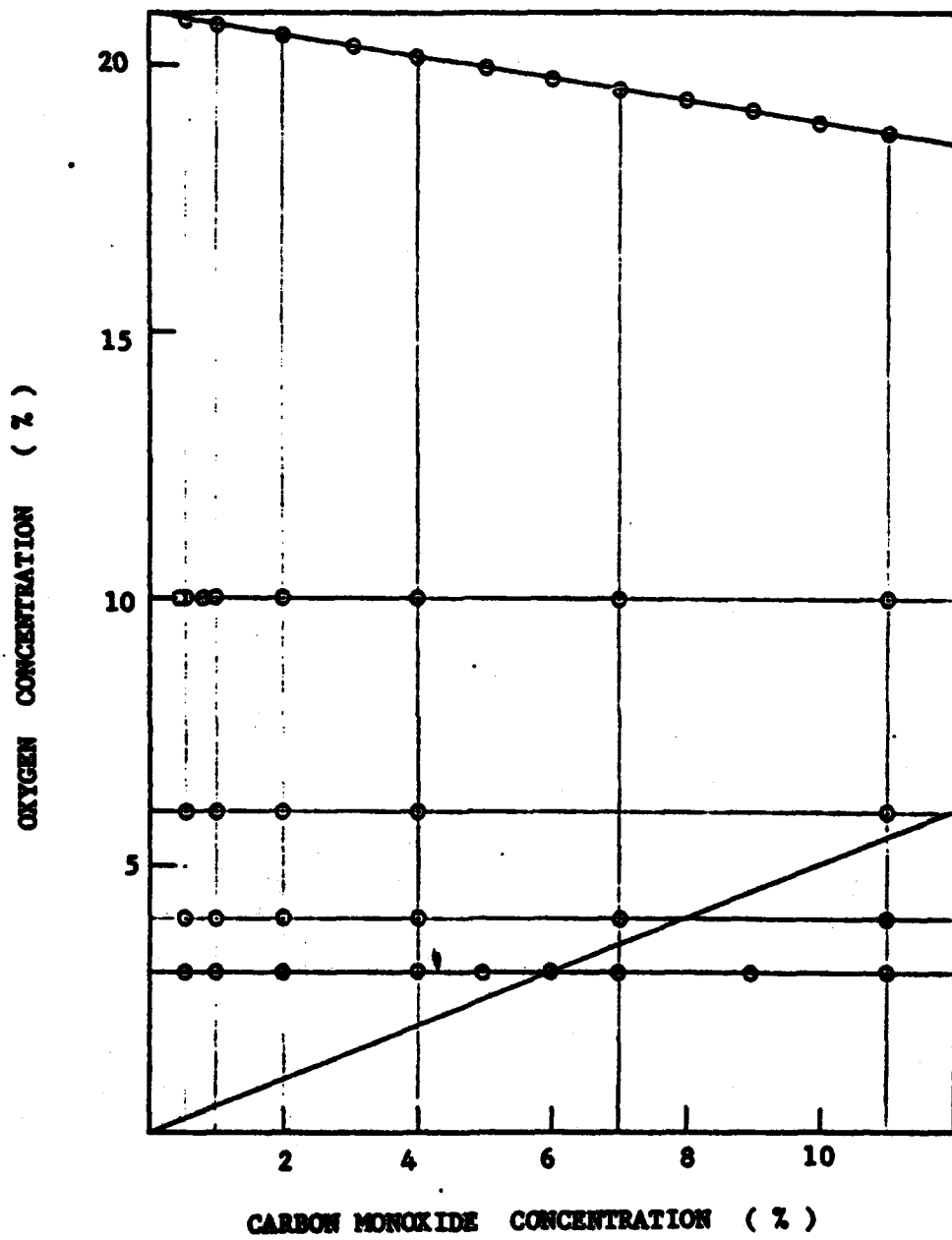

Figure 4.18 Concentration map of carbon monoxide/oxygen/nitrogen mixtures

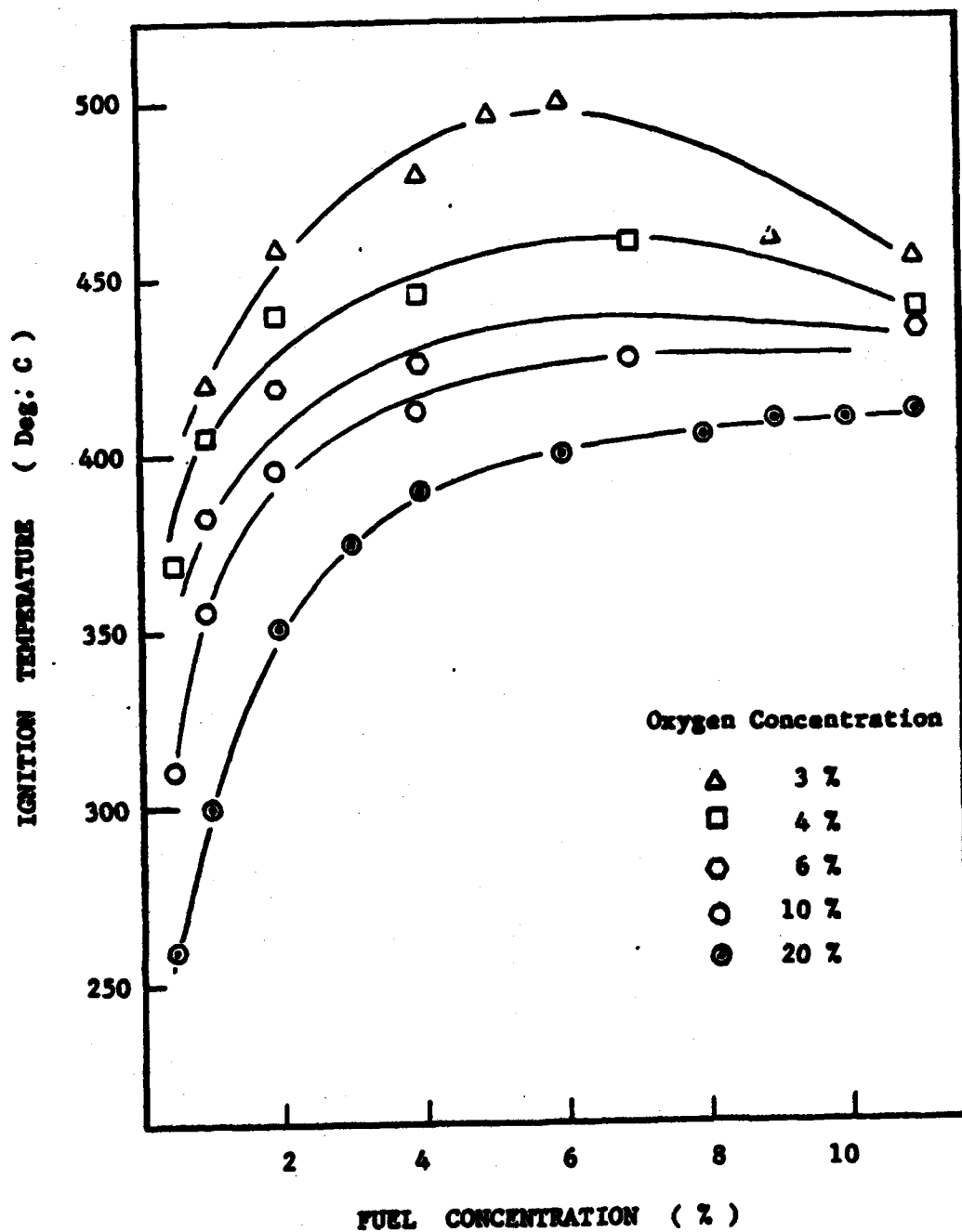
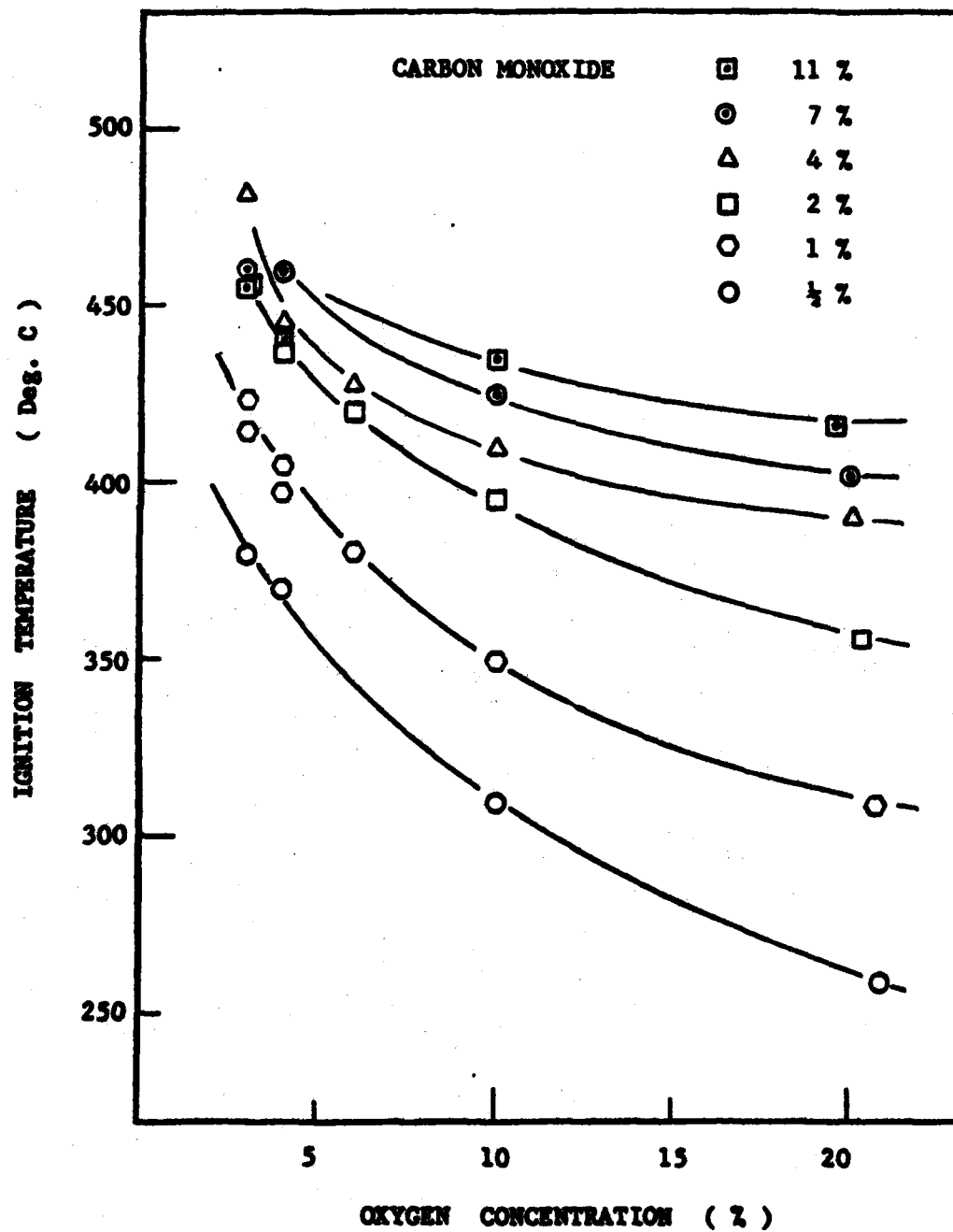

Figure 4.19 Ignition temperature of carbon monoxide/oxygen/nitrogen mixtures at constant oxygen concentrations



**Figure 4.20 Ignition temperature of carbon monoxide/oxygen/nitrogen mixtures at constant carbon monoxide concentration**

ignition temperature of carbon monoxide/oxygen/nitrogen mixtures. It shows that, at all fuel concentrations, the ignition temperature decreases with an increase in the oxygen concentration. However, the most distinct change is observed for the lean mixtures. For example, a reduction of over 120°C is obtained for mixtures containing 0.5% fuel as compared to mere 65°C for mixtures with 11% fuel. Such a large change in the ignition temperature is comparable in magnitude to the changes brought about by variations in the fuel concentrations. This is a strong indication of the competitive nature of the interaction between reactants at the catalytic surface. Note that the trend observed here for carbon monoxide contrasts well with that of propane (see Fig. 4.12).

#### 4.5 SECONDARY EFFECTS

In addition to the fuel and oxygen concentrations there are two more factors that can affect the catalytic ignition. One is the effect of convective mass transport rate, and the other is the history of the catalyst. They do not, however, influence the ignition temperature to an equal extent. Their influence is also felt for different fuels to varying degrees.

Two fuels tested are hydrogen and propane. The effect of mass transport rate is presented first and the effect of pre-treatment of the catalyst follows.

##### 4.5.1 Effect of Velocity

The convective mass transport rate can be enhanced by increasing

the flow velocity of the fuel/air mixture. The previous discussion on the limits of catalytic reactions (Section 2.1.3) has shown that an increase in the flow velocity helps the reaction to stay in the kinetically controlled regime; the catalyst can then be utilized to its full reactivity. However, there is another effect of increased velocity. When the flow velocity is increased the time a given gas molecule will spend near the surface decreases. That is, the residence time of the reactants within the reacting environment is shortened. Since the molecules have less time to react, ignition would consequently be more difficult to achieve. A higher surface temperature can, however, provide a more intense reacting environment for the molecules such that the molecules can be equally excited in a shorter time period. Therefore, a mixture flowing at a higher velocity would require a correspondingly higher temperature for ignition.

Figure 4.21 shows the effect of velocity on propane/air and hydrogen/air mixture. The velocity increase by a factor of four does not change the ignition temperatures appreciably for both mixtures. Nevertheless, the general trend is, as expected, an increase in ignition temperature with an increase in the flow velocity.

#### 4.5.2 Effect of Pre-treatment of the Catalyst

Figures 4.22 and 4.23 show that the ignition temperature is affected by the history of the catalytic surface. In the case of propane/air mixtures, the newly activated catalyst is more active than the aged catalysts, as implied by easier ignitions. In contrast, the

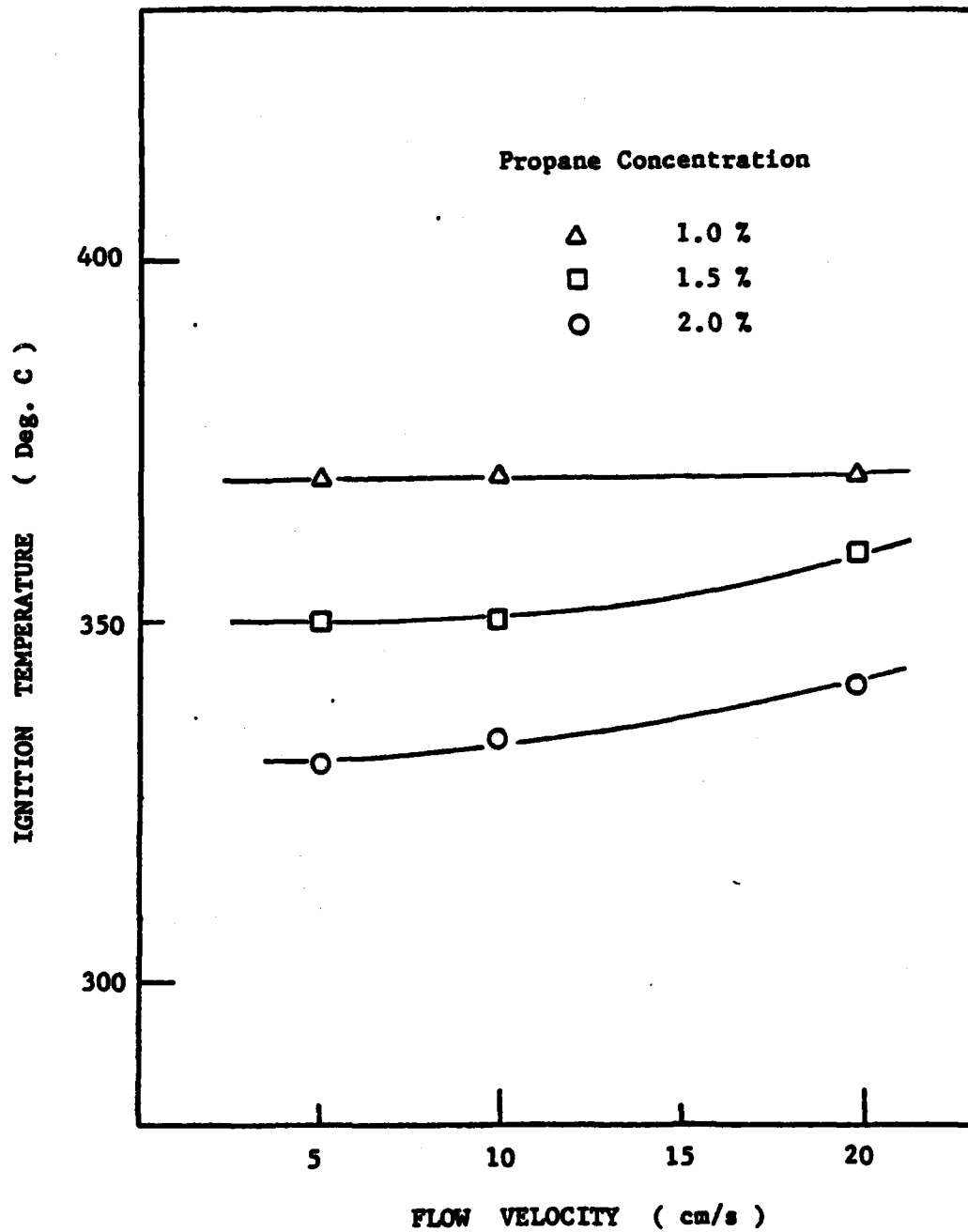

Figure 4.21(a) Effect of flow velocity on the ignition temperature: propane/air mixtures

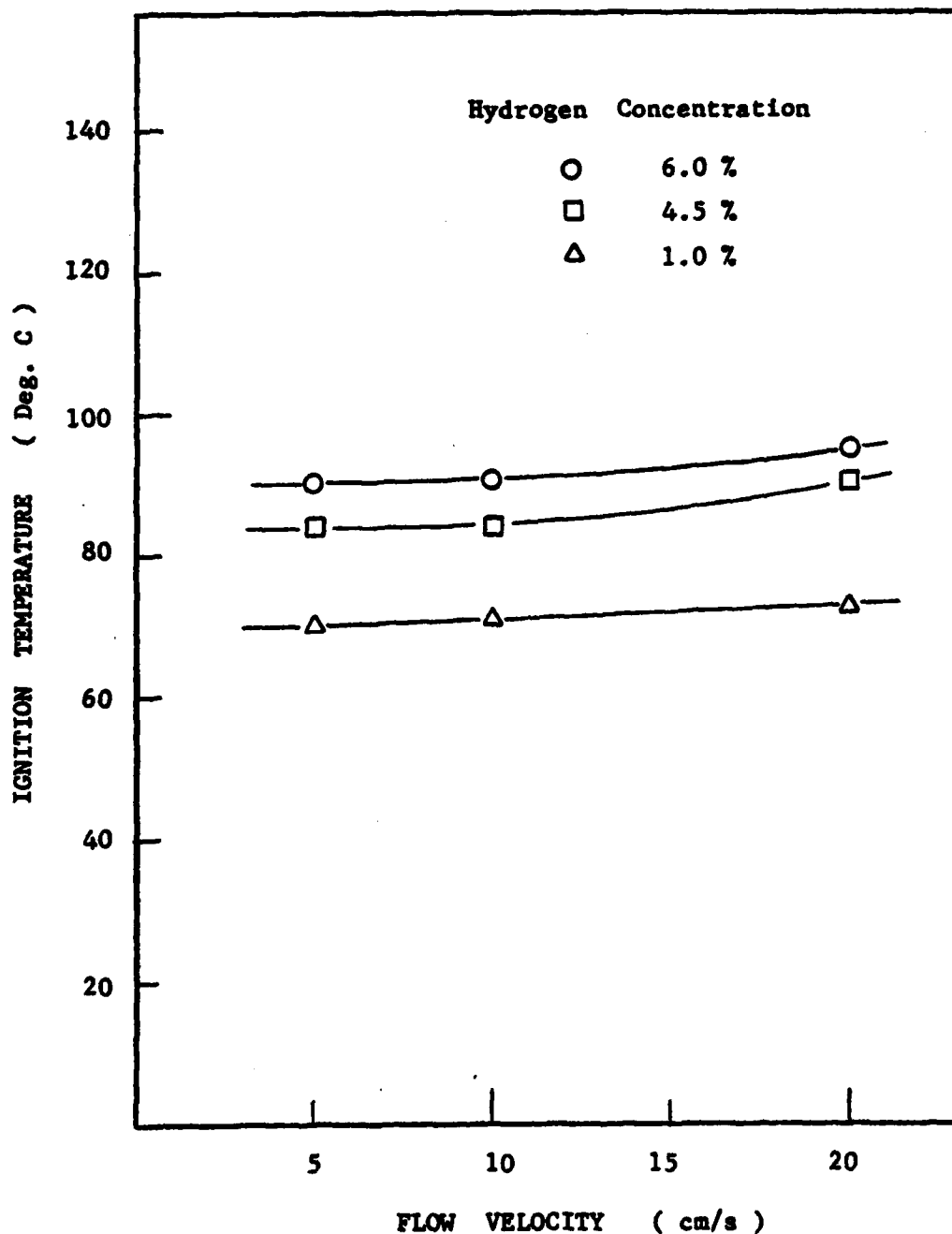

Figure 4.21(b) Effect of flow velocity on the ignition temperature: hydrogen/air mixtures

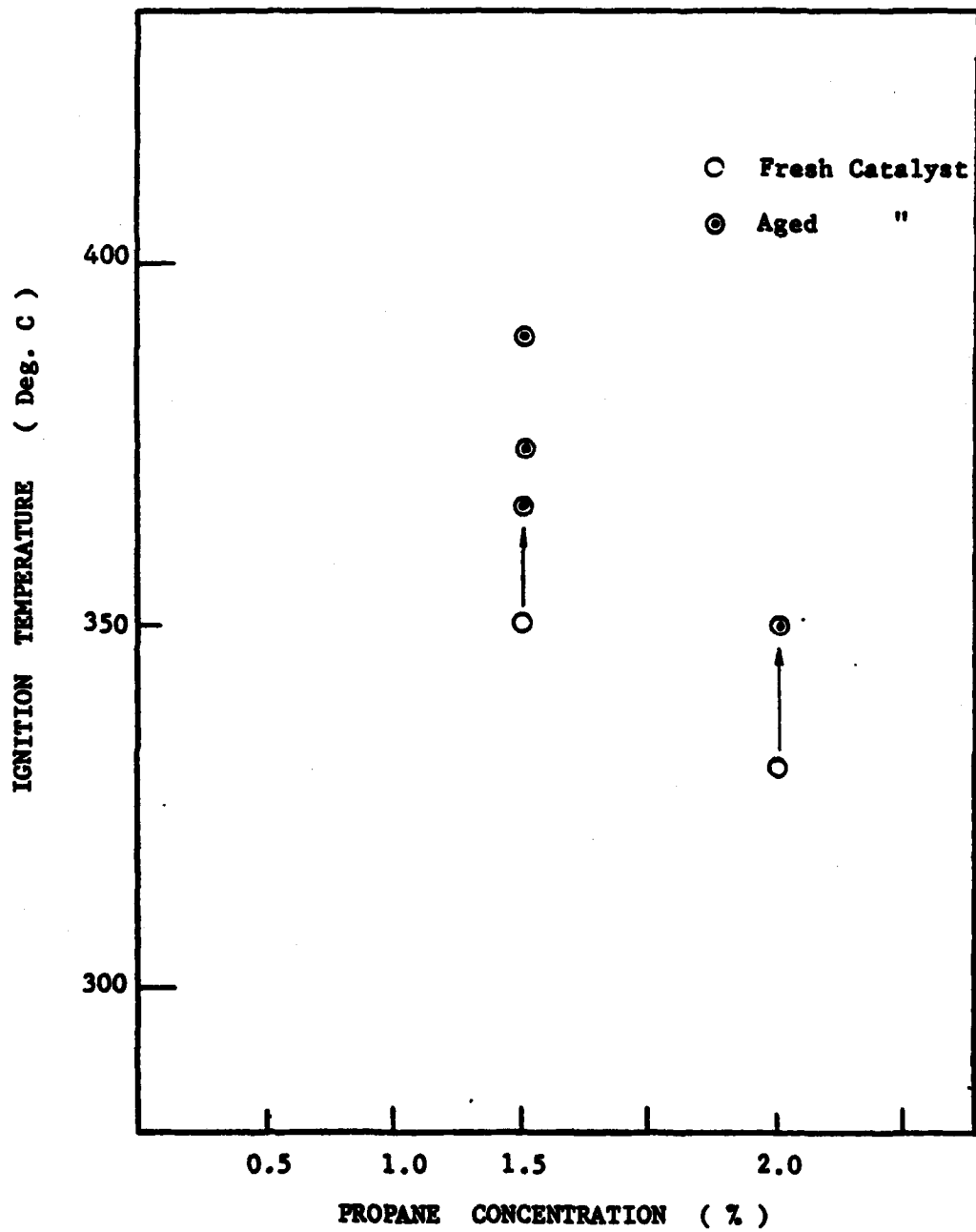

Figure 4.22 Effect of aging on the ignition temperature: propane/air

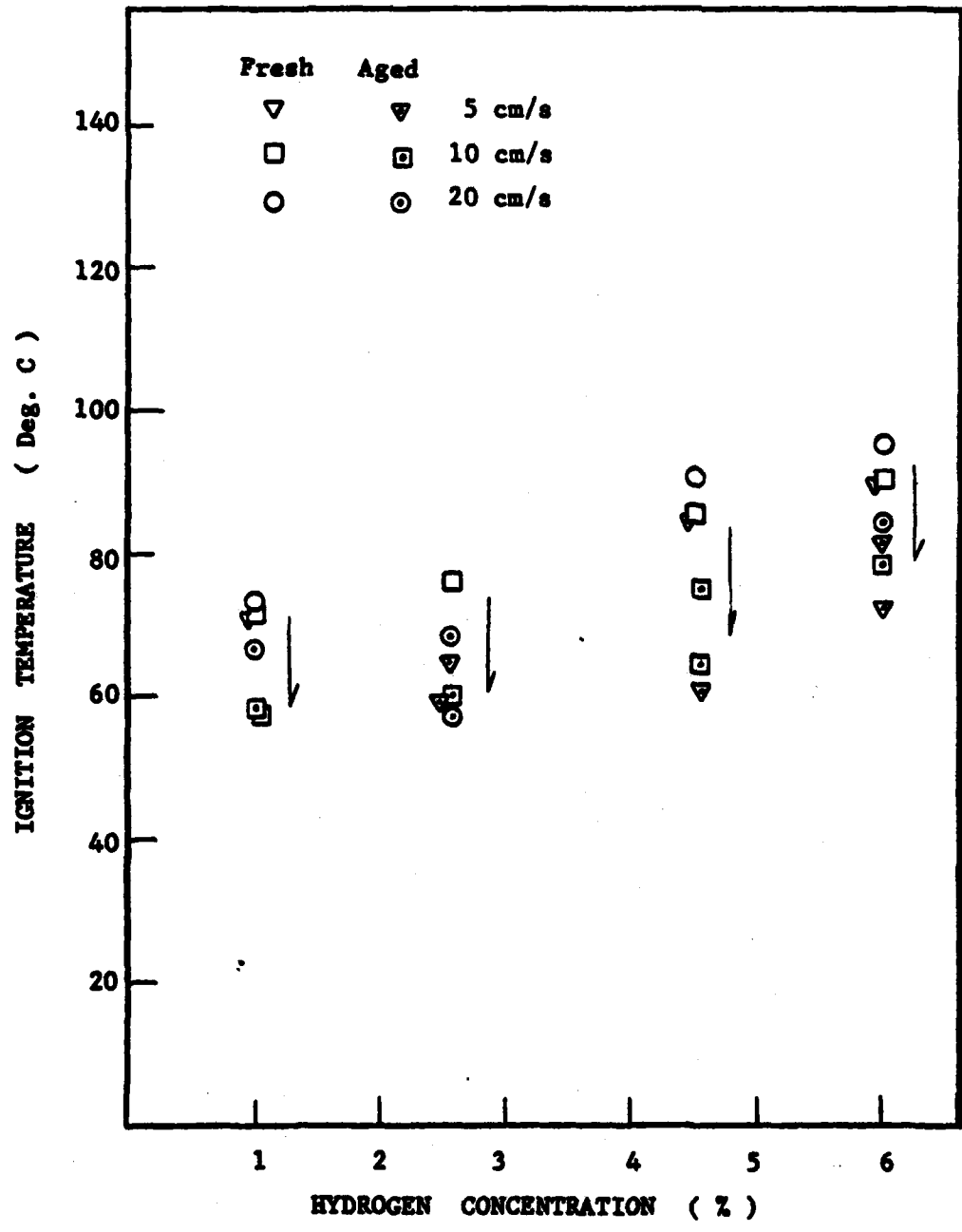

Figure 4.23 Effect of aging on the ignition temperature: Hydrogen/air mixtures

newly activated catalyst is least effective in igniting hydrogen/air mixtures. The reason for the difference can be explained by the surface conditions of the aged catalyst. The word "aged" is used here to describe a catalyst that is not reactivated in between experiments. Thus, the aged catalyst carries the history of the previous reactions.

When the catalyst surface is examined through a powerful microscope one can observe dark spots left behind after an ignition of propane/air mixture. The residue is most likely either the non-volatile impurities introduced with the mixture or carbon particles formed during reactions. In either case the aftereffect of an experiment is to make the surface ignition more difficult.

#### 4.6 SUMMARY

The study on the ignition temperature of propane, butane, propylene, ethylene, carbon monoxide and hydrogen has revealed two distinctively opposing trends. The ignition temperature of lean propane/air and butane/air mixtures decreases as their concentration is increased. However, the ignition of propylene, ethylene, carbon monoxide and hydrogen is made more difficult as the amount of fuel in the mixtures is increased.

For both groups of fuel the sharpest change in the ignition temperature is obtained at low fuel concentrations. At higher concentrations the change gradually tapers off indicating a minimum ignition temperature for the fuels in the propane group and a maximum for the fuels in the propylene group. The limiting ignition temperature

is found for propane and carbon monoxide by using fuel/oxygen/nitrogen mixtures in which a large amount of nitrogen is added as a diluent to suppress gas-phase ignition. The minimum temperature of propane is about 285°C and occurs at the fuel concentration of approximately 5%. The maximum ignition temperature of carbon monoxide is dependent on the oxygen concentration. Therefore, the effect of oxygen concentration on the ignition is also studied. The result shows that propane displays a minimum on the lean side of stoichiometry. The total change in the ignition temperature is 35°C as the oxygen concentration is decreased from 20% to 4% as compared to a change of 70°C observed when the fuel concentration is changed from 0.5 to 2%.

For carbon monoxide, the changes in oxygen concentration do not display any abrupt change in the ignition temperature.

The different ignition behavior of fuels is explained from the viewpoint of the difference in the adsorption strength of the fuel molecules relative to that of oxygen molecules. The preferential chemisorption of oxygen in the oxidation reactions of propane and butane is compared to the competitive chemisorption of oxygen and the fuel molecules of the propylene group.

Finally, the effect of velocity and aging is studied. The changes in the flow velocity is shown to exert no influence on the ignition temperature as long as the Reynolds number is very small. The aging effect can be substantial. This shows that the reactivation procedure after each ignition is essential to preserve the constancy of catalytic reactivity.

## CHAPTER 5

### HEAT RELEASE RATE

#### 5.1 GENERAL OBSERVATIONS

Chemical heat release rates of catalytic reactions have been measured by several researchers (Ablow et al., 1980; Robben et al., 1977; Schefer et al., 1980) is an effort to extract the important kinetic parameters from the data. The basis for the analysis has already been briefly discussed in the earlier section on experimental methodology (Section 3.1.2). In this chapter, we shall examine in more detail the principle behind the energy balance.

##### 5.1.1 Theory

The measurement of chemical heat release rate by micro-calorimetry is basically a thermal energy method. Hence, the starting point of the theory is the overall energy balance.

Consider a wire heated electrically in a heat conducting medium. If the system is in thermal equilibrium, then the heat generated must be equal to the heat loss. In a non-combustible mixture the heat is generated solely from the electrical resistive heating of the wire. This is balanced by the heat losses from the wire by convection, conduction and radiation to the on-coming flow and by axial conduction in the wire. That is,

$$P = Q_h + Q_k + Q_r + Q_e$$

where  $P$  is the resistive heating in the wire while the heat loss terms are identified by the subscript  $h$  for convection,  $k$  for conduction,  $r$

for radiation, and  $e$  for axial loss through wire ends.

In a combustible environment an additional term due to chemical heat generation must be considered. The new thermal balance for an isothermal system is

$$P' + \Delta Q_R = Q'_h + Q'_k + Q'_r + Q'_e$$

where the primed quantities may be different from their unprimed counterparts in the previous energy balance equation.

When the two equations are combined and rearranged to explicitly express the chemical heat release rate the resulting equation is

$$\Delta Q_R = \Delta P + (Q'_h - Q_h) + (Q'_k - Q_k) + (Q'_r - Q_r) + (Q'_e - Q_e)$$

where  $\Delta P = P - P'$ , the difference in the electrical power consumed.

The four energy loss terms need to be examined closely. The radiative heat transfer terms in a reacting and a non-reacting flow are identically equal to each other since the surface and the ambient temperatures remain constant and the highly luminous carbon particles are absent during surface reactions. The heat loss through the wire ends is also constant. Therefore, the last two terms in the expression for  $\Delta Q_R$  do not contribute anything to the equation.

The same conclusion, however, cannot be made for the heat losses due to convection and conduction. Generally, these two terms can be expressed in a combined form as

$$Q_h + Q_k = \alpha(T_s - T_o)$$

where  $\alpha$  is the net heat transfer coefficient. Even though the temperature difference ( $T_s - T_o$ ) does not change, the heat losses in a reacting and non-reacting condition can be quite large through changes in the coefficient  $\alpha$ . The difference in  $\alpha$  is caused by introducing fuel to the air stream to render it reactive and, theoretically, the heat transfer characteristic of the fuel/air mixture should be different from that of the air. The difference cannot be ignored if a large quantity of fuel such as methane or hydrogen is mixed with air because both gases have thermal properties that are radically different from air which is basically all nitrogen. However, in the present experimental investigation usually only small amounts of fuel are added; an exceptional case is carbon monoxide/air mixtures in which as much as 10% fuel is introduced. However, the thermal properties of carbon monoxide do not deviate much from that of air. Consequently, for all practical purposes the changes in the heat loss terms due to conduction and convection can be safely assumed to be zero.

The only remaining term in the expression for  $\Delta Q_R$  is  $\Delta P$ , i.e.,  
 $\Delta Q_R = \Delta P$ .

In conclusion, the chemical heat release can be measured as the difference in the external heat input needed to maintain a catalytic surface at a constant temperature in reacting and non-reacting conditions.

The next step in the analysis involves a number of crude assumptions which are necessary because of ignorance in the field of

kinetic modeling. The first assumption is that all the intricate interactions among the reactants and the catalytic surface, as discussed in Section 2.1, can be represented by an overall reaction rate such that

$$(r.r.) = kC_s$$

where  $k$  is the rate constant and the reaction rate is assumed to be first order in the surface concentration of fuel. This particular assumption on the dependence of the reaction rate on the reactant concentration is quite inadequate, if not sometimes outright erroneous, in describing even the bare essentials of heterogeneous catalytic reactions. But, as discussed in Section 4.2.3, information is not available to properly describe even a relatively simple reaction in reacting conditions.

The heat release rate is then obtained by multiplying the heat of reaction ( $\Delta H_R$ ) and the reaction rate such that

$$\Delta Q_R = (r.r.)(\Delta H_R)$$

Therefore,  $\Delta P = kC_s(\Delta H_R)$ .

Further assuming that the rate constant obeys the Arrhenius expression, i.e.  $k = A \exp(-E/RT)$ , the equation can be arranged to give

$$\ln \left[ \frac{\Delta P}{C_s} \right] = -\frac{E}{R} \left( \frac{1}{T} \right) + \ln A(\Delta H_R)$$

showing that the measurement of  $\Delta P$  leads to the kinetic parameters  $E$  and  $A$ .

Even if the above ratio expression is valid for a special case, there is yet another shortcoming that makes the analysis difficult. The

heat release rate analysis is limited by its inability to specify the surface concentration  $C_s$  without resorting to a trial and error type of matching with computational analysis by using a mathematical model.

### 5.1.2 Literature Survey

The difficulty in the analysis based on measuring the chemical heat release rate is reflected in the small number of publications on the subject. The first measurement of the heat release rate in combustion studies is by Cardoso and Luss (1969) who have used the heated-gas technique for carbon monoxide and butane oxidation in air. In their work the effect of changing the flow velocity and the fuel concentration have been reported, but no kinetic information is given. The heat release rate in a stagnation point boundary layer reaction of propane/air has been studied by Ablow et al. (1980) but, again, no kinetic parameters have been determined.

The only work in which the kinetic constants A and E are obtained from Arrhenius plots is by Schafer et al. (1983). Their investigation, based on flat plate boundary layer reaction of lean hydrogen/air mixtures, incorporates a mathematical model to determine the surface fuel concentration that would match the experimentally measured heat release rates. There are a number of intrinsic difficulties associated with the measurement of heat release rate using catalytic film deposited on a quartz substrate. Nonetheless, their work represents an important step towards a better kinetic modelling of catalytic combustion systems.

### 5.1.3 The Scope of Present Work

No attempt is made in this thesis to extract the kinetic parameters from the measured heat release rates because of two overwhelming shortcomings of the analysis based on thermal energy balance. The difficulty associated with the determination of surface concentration has been mentioned. The second difficulty is that the analysis is also limited by the complexities of chemical reactions at high temperature where the reactions are either diffusion limited or homogeneous-heterogeneous reaction hybridized.

The heat release rates measured from the diffusion limited reactions do not reflect the true kinetics at the catalyst surface because the reaction rate is controlled by the rate of mass transport. On the other hand, in a situation where gas-phase reaction is supported by surface reaction the measured heat release rate is the net result from both reactions. Again, the true surface kinetics can be falsified by the overall effect (Rajadhyaksha and Doraiswanay, 1976).

A number of attempts have been made to assess the relative contributions of homogeneous and heterogeneous reactions to the total heat release rate in a catalytic reaction (Bensalem and Ernst, 1982; Harrison and Ernst, 1978; Margolis, 1973). However, the development of homogeneous-heterogeneous reaction model is still in the infant stage.

In spite of the limitations in the analysis the results of various effects on the heat release rates are presented because the observed trends can provide important insights into the mechanisms of catalytic combustion systems. Specifically, the effect of fuel and oxygen

concentrations, flow velocity, and aging have been mapped for many practical fuels.

## 5.2 EFFECT OF FUEL AND OXYGEN CONCENTRATION

The effect of fuel and oxygen concentration on chemical heat release rates are reported in two parts: The first part concerns with fuel/air mixtures; the second, with a more detailed study on fuel/oxygen/nitrogen mixtures. The detailed study is limited to carbon monoxide and propane.

### 5.2.1 Fuel/Air Mixtures

The effects of fuel concentration on the heat release rates of propane, butane, propylene, carbon monoxide and hydrogen oxidation in air are presented in Figures 5.1 to 5.5 respectively. Generally, the heat release rate increases with the surface temperature but soon reaches a steady value, indicating the transition from kinetic controlled regime to the diffusion limited regime. The transition occurs at different moments for different fuels. For example, the heat release rate,  $\Delta Q_R$ , for propane/air mixtures seems to increase steadily without showing much tendency to level off to a constant value whereas  $\Delta Q_R$  for butane/air and propylene/air mixtures become limited by diffusion after a sharp increase over the low temperature range. The  $\Delta Q_R$  profile becomes flatter for carbon monoxide oxidation and in the limit, a completely diffusion limited  $\Delta Q_R$  is obtained for hydrogen/air oxidation.

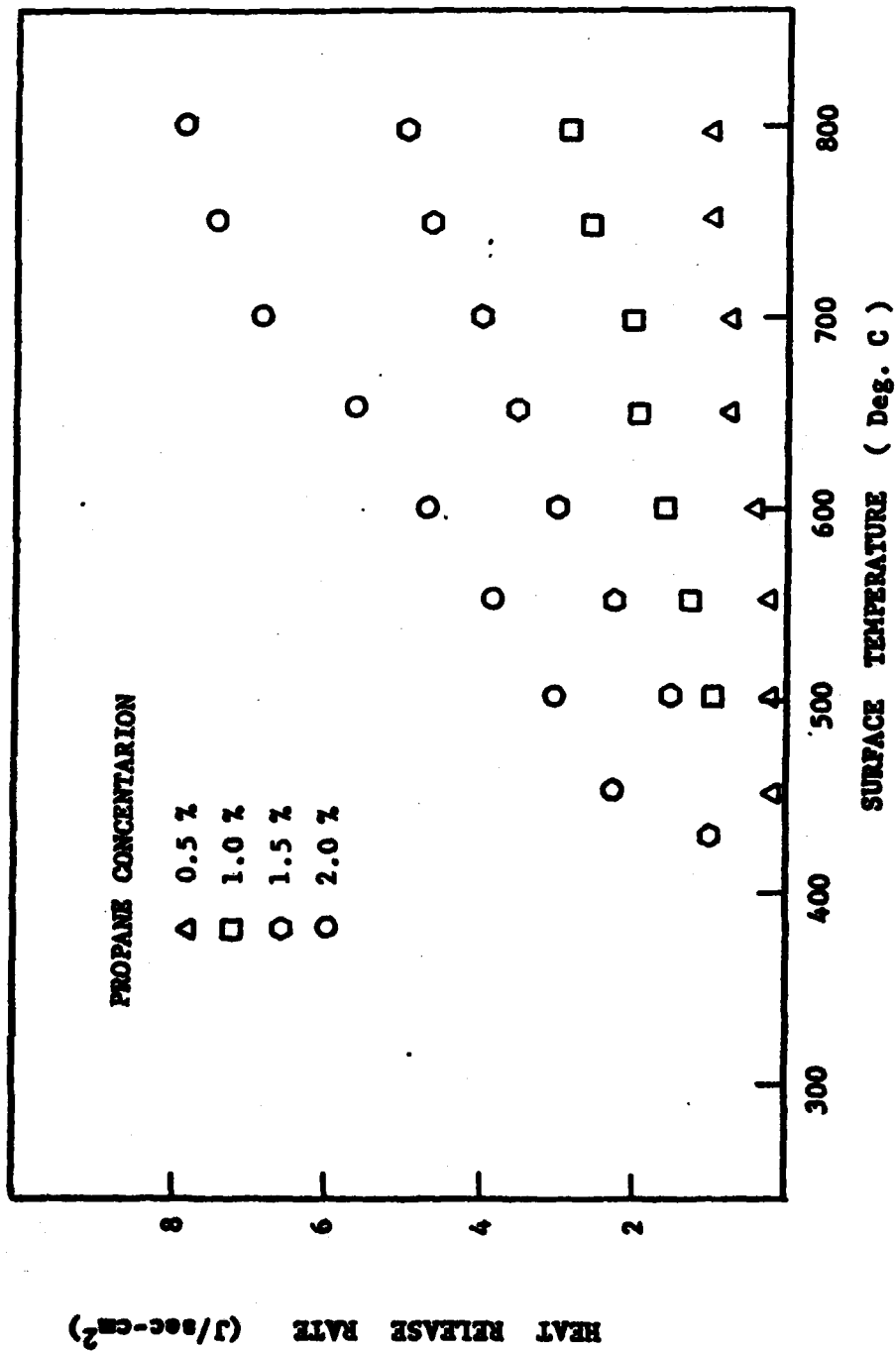

Figure 5.1 Effect of fuel concentration on the heat release rate of propane/air mixtures

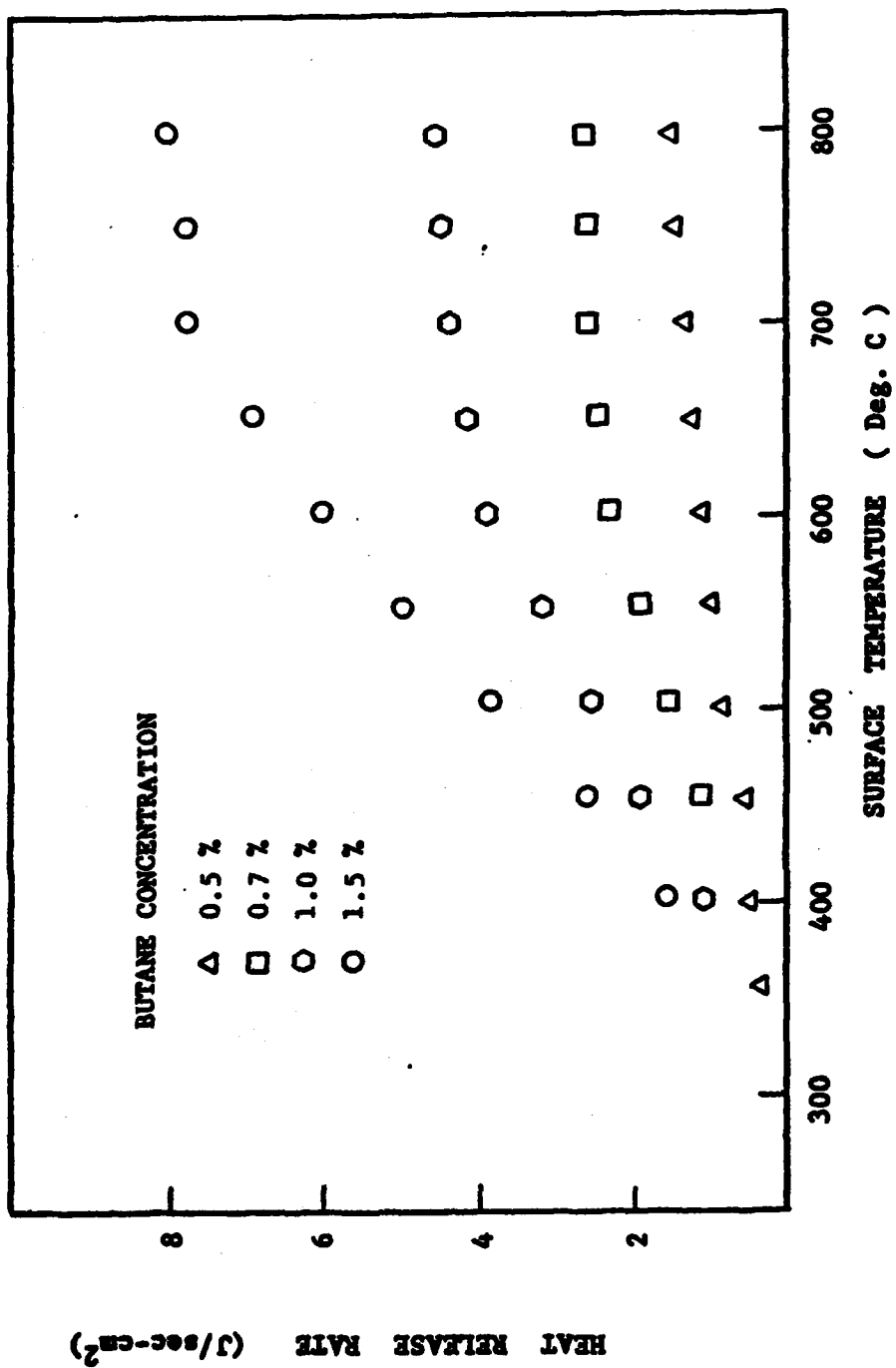

Figure 5.2 Effect of fuel concentration on the heat release rate of butane/air mixtures

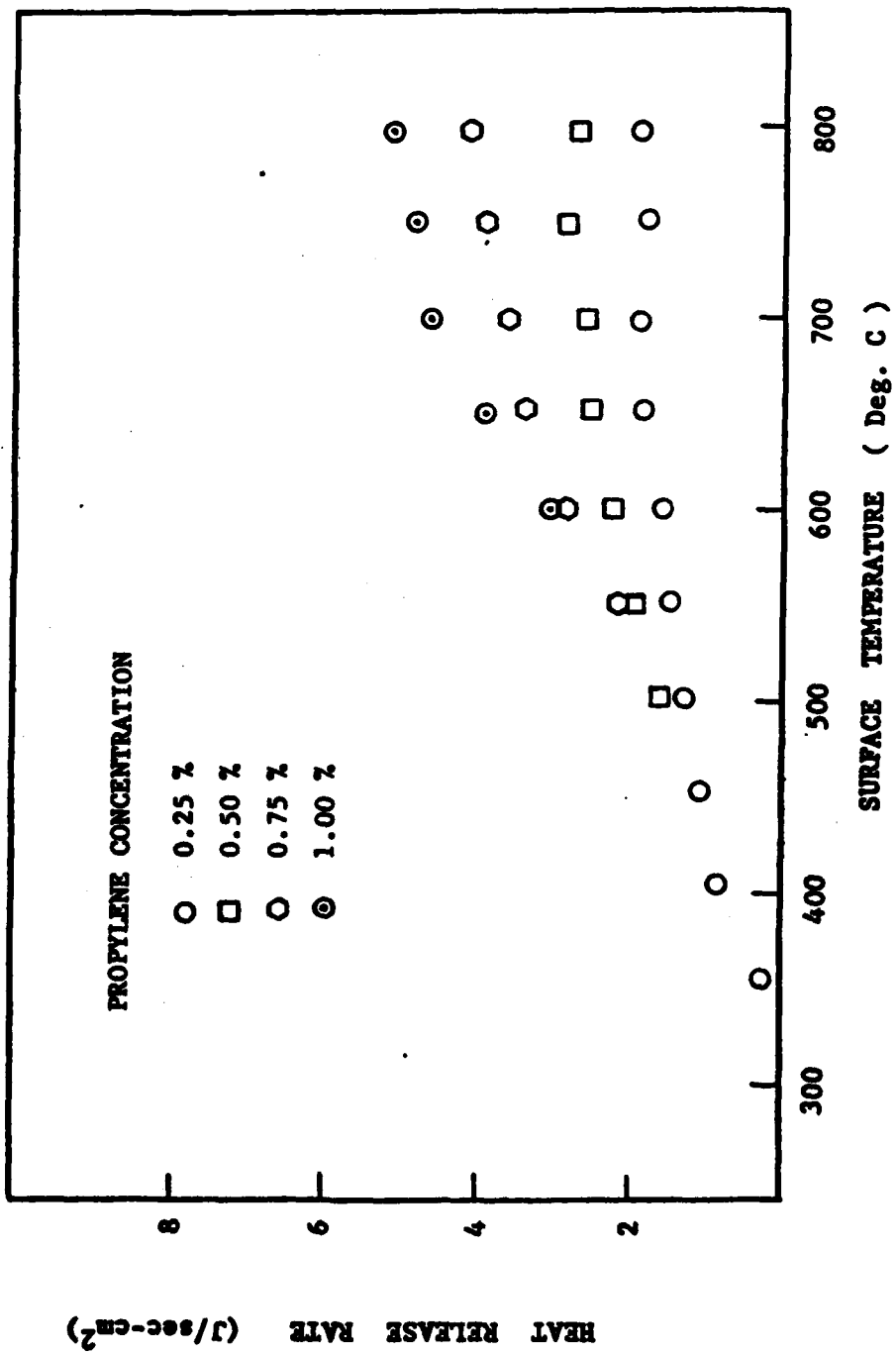

Figure 5.3 Effect of fuel concentration on the heat release rate of propylene/air mixtures

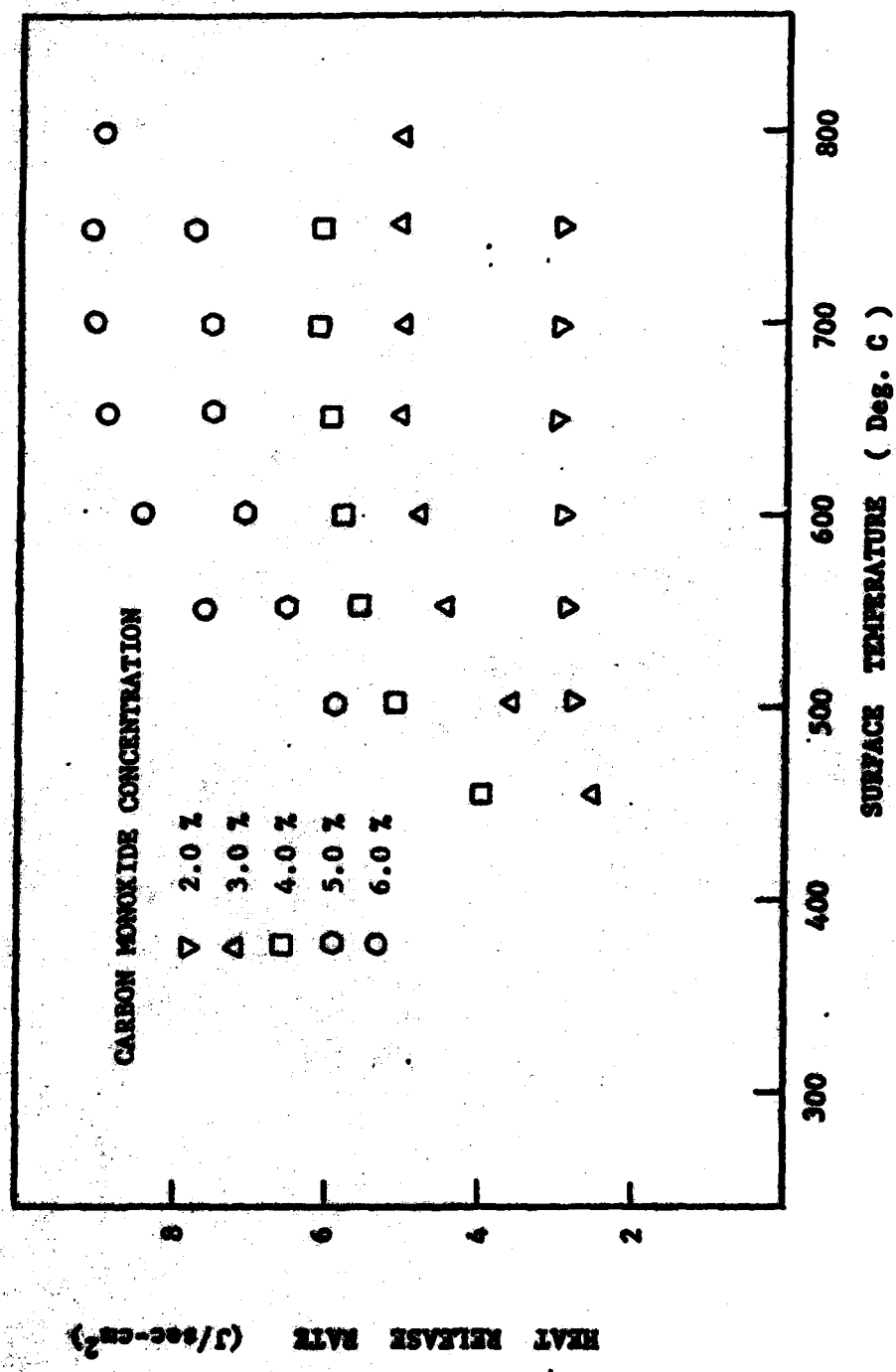

Figure 5.4 Effect of fuel concentration on the heat release rate of carbon monoxide/air mixtures

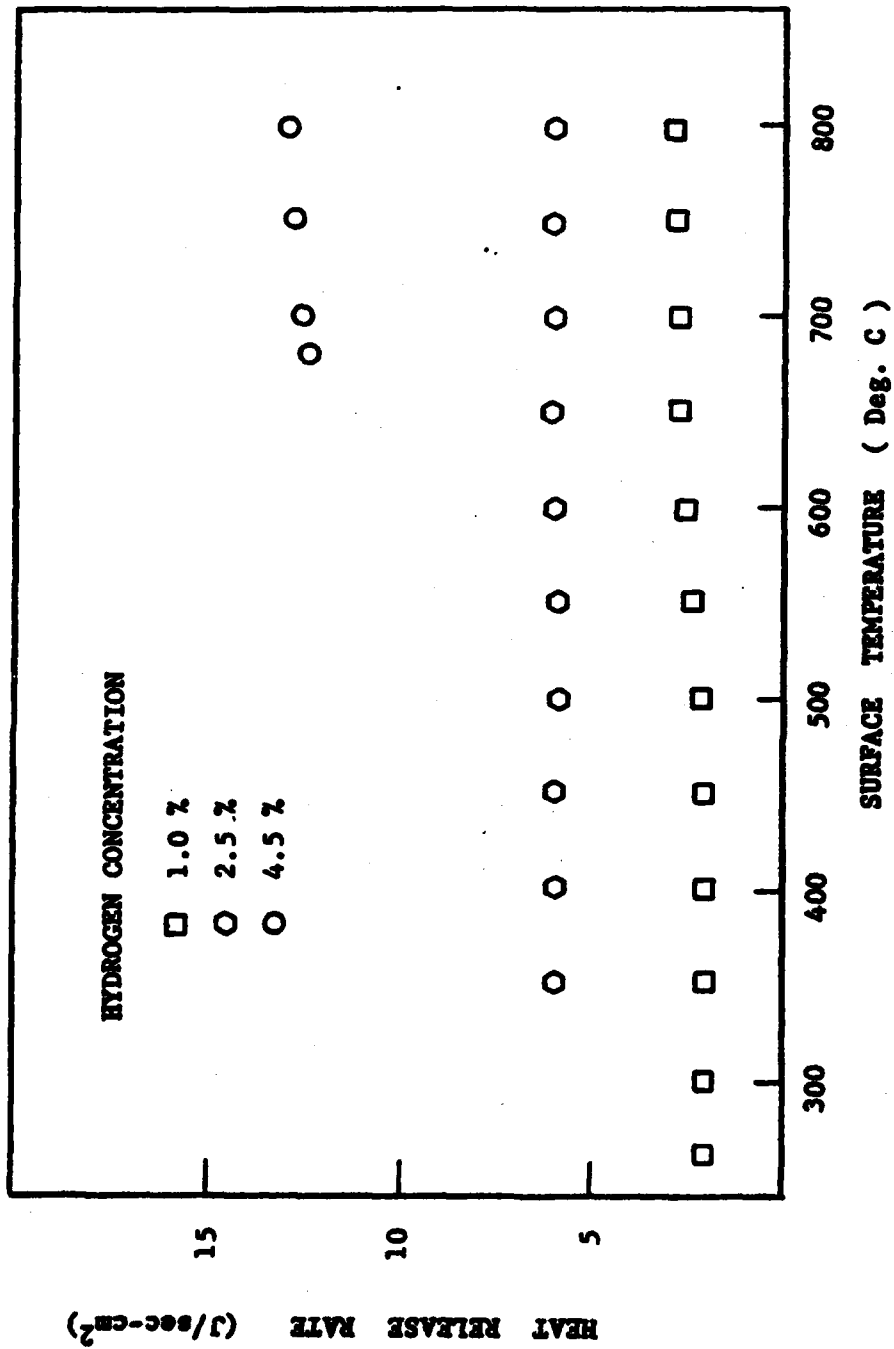

Figure 5.5 Effect of fuel concentration on the heat release rate of hydrogen/air mixtures

For hydrogen/air mixtures the heat release rates cannot be studied over the lower surface temperature range because with the large amount of chemical heat liberated the surface cannot be maintained at a constant temperature even when no electrical heating is applied. That is, the hydrogen/air reaction is so intense that thermal equilibrium with the surrounding can only be achieved at a higher temperature. Therefore, unlike other fuel/air reactions which can be extinguished by the removal of external heat source (electrical resistive heating), hydrogen/air reactions are self-sustained once they are ignited.

#### 5.2.2 Fuel/Oxygen/Nitrogen Mixtures

The effect of fuel concentration on  $\Delta Q_R$  is examined by keeping the oxygen concentration constant. Not all mixtures could be studied because the heat release rates from some of the richer mixtures are very high. Then, as in the case of hydrogen/air mixtures, once the mixture is ignited it will provide enough energy not only to self-sustain the reaction even in the absence of external heating, but also to drive up the surface temperature beyond the experimental range.

One way to limit the temperature rise is to dilute the mixture with large amount of nitrogen or some other inert gas. Then, much of the heat released during chemical reaction is used up by the nitrogen molecules which are present in the mixture in a disproportionately large amount. Also, in a mixture with a small amount of oxygen the sensitivity of the mixture to fuel concentration variation is greatly enhanced. For example, when propane concentration is increased from 0.5

to 1.5% in a mixture with 10%  $O_2$  the mixture is still lean. But for the same change in the mixture with 4%  $O_2$  the mixture strength changes from very lean to very rich case.

The results are shown in Figures 5.6(a) - 5.6(d) for oxygen concentrations of 10, 7.5 and 4%. It is seen that in the case of 10%  $O_2$  the  $\Delta Q_R$  measurement could be made with only the two leaner mixtures containing 0.5% and 1.5%  $C_3H_8$ . For mixtures with 7.5%  $O_2$  the fuel concentration is again limited to 1.5% which represents a stoichiometrically correct mixture. In both figures the heat release rates are shown to increase with increase in fuel concentration. However, the result for the mixture with 4%  $O_2$  shows that the  $\Delta Q_R$  keeps on increasing even if the mixture is well above the stoichiometric strength. Only when the mixture becomes very rich ( $\phi = 2$ ) the  $\Delta Q_R$  begins to decrease.

The results for carbon monoxide oxidation are shown in Figures 5.7(a) - 5.7(d). The general trends are the same as for propane. Here, the decrease in  $\Delta Q_R$  with increase in  $T_g$  is not observed because even at 11% CO and 3%  $O_2$  the mixture is not rich to show the full trend. The equivalence ratio of this mixture is only 1.8 as the stoichiometric fuel concentration for carbon monoxide oxidation in air is 29.5%.

### 5.3 EFFECT OF FLOW VELOCITY AND AGING

When a catalyst wire is in a stagnant chamber filled with reactants the reactant concentration profile is exactly axisymmetric around the wire. The reactants are supplied from all azimuthal angle and, since

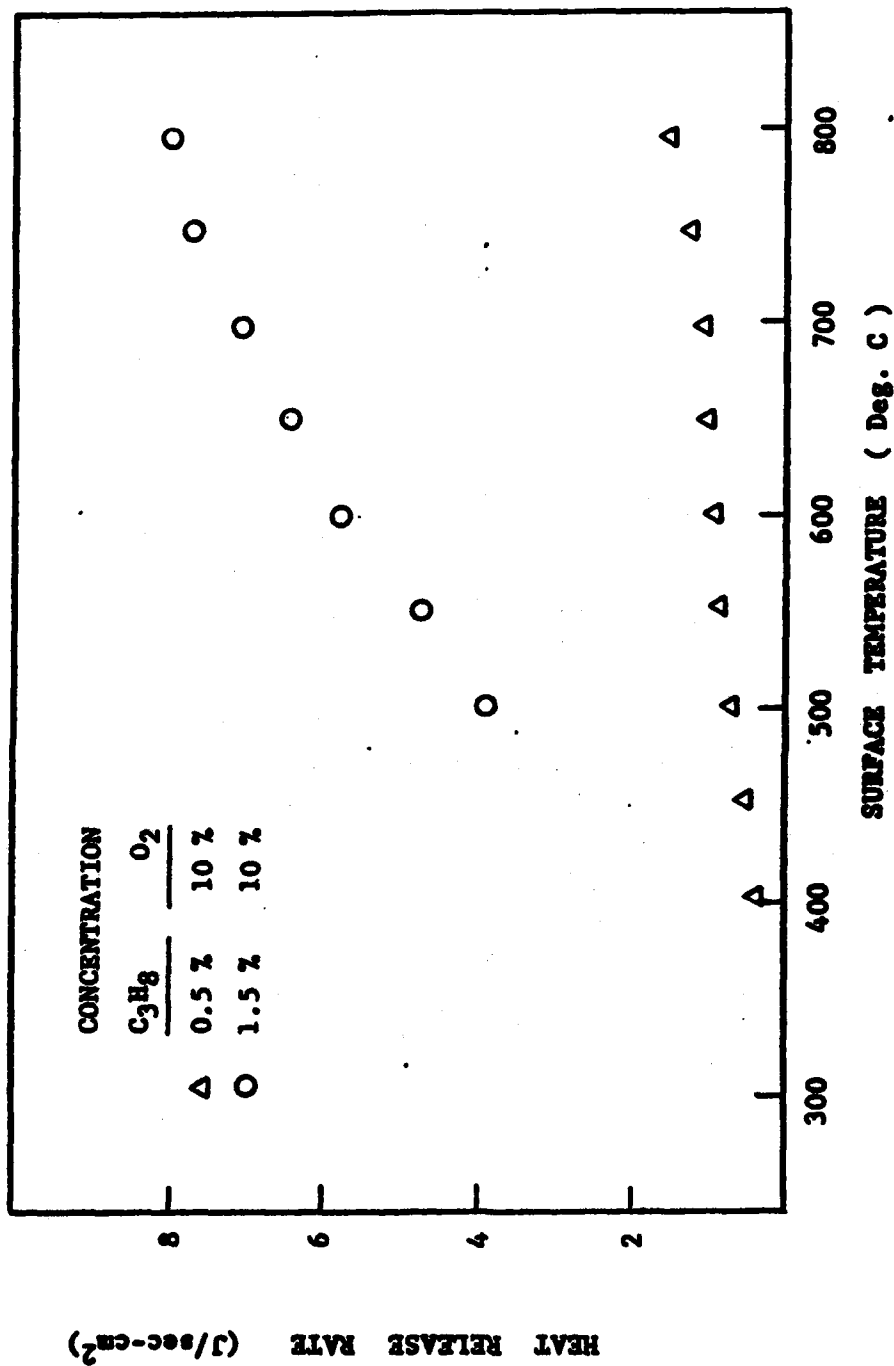

Figure 5.6(a) Heat release rate of propane/oxygen/nitrogen mixtures at constant oxygen concentrations: 10%  $O_2$

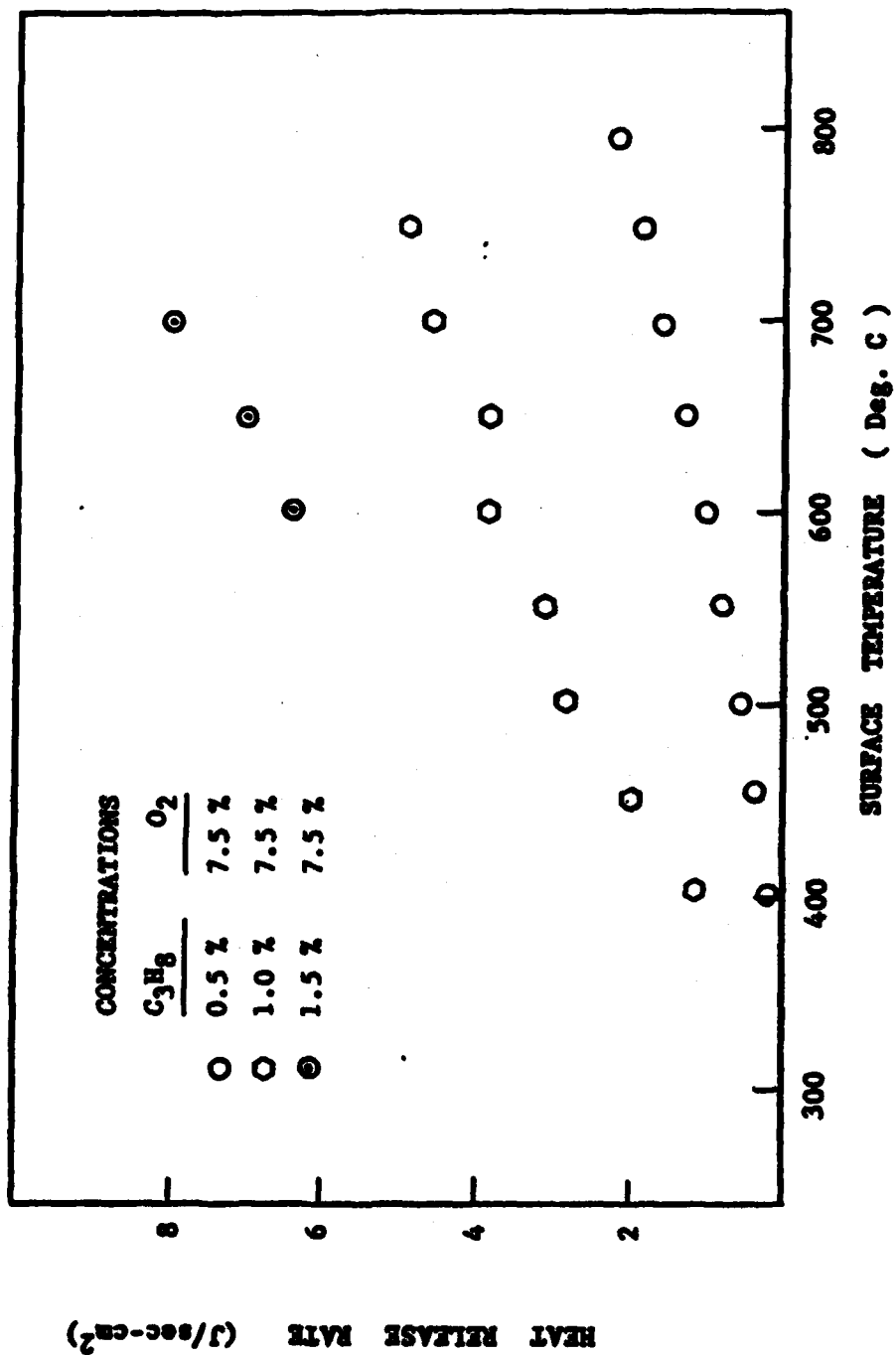

Figure 5.6(b) Heat release rate of propane/oxygen/nitrogen mixtures at constant oxygen concentrations: 7.5%  $O_2$

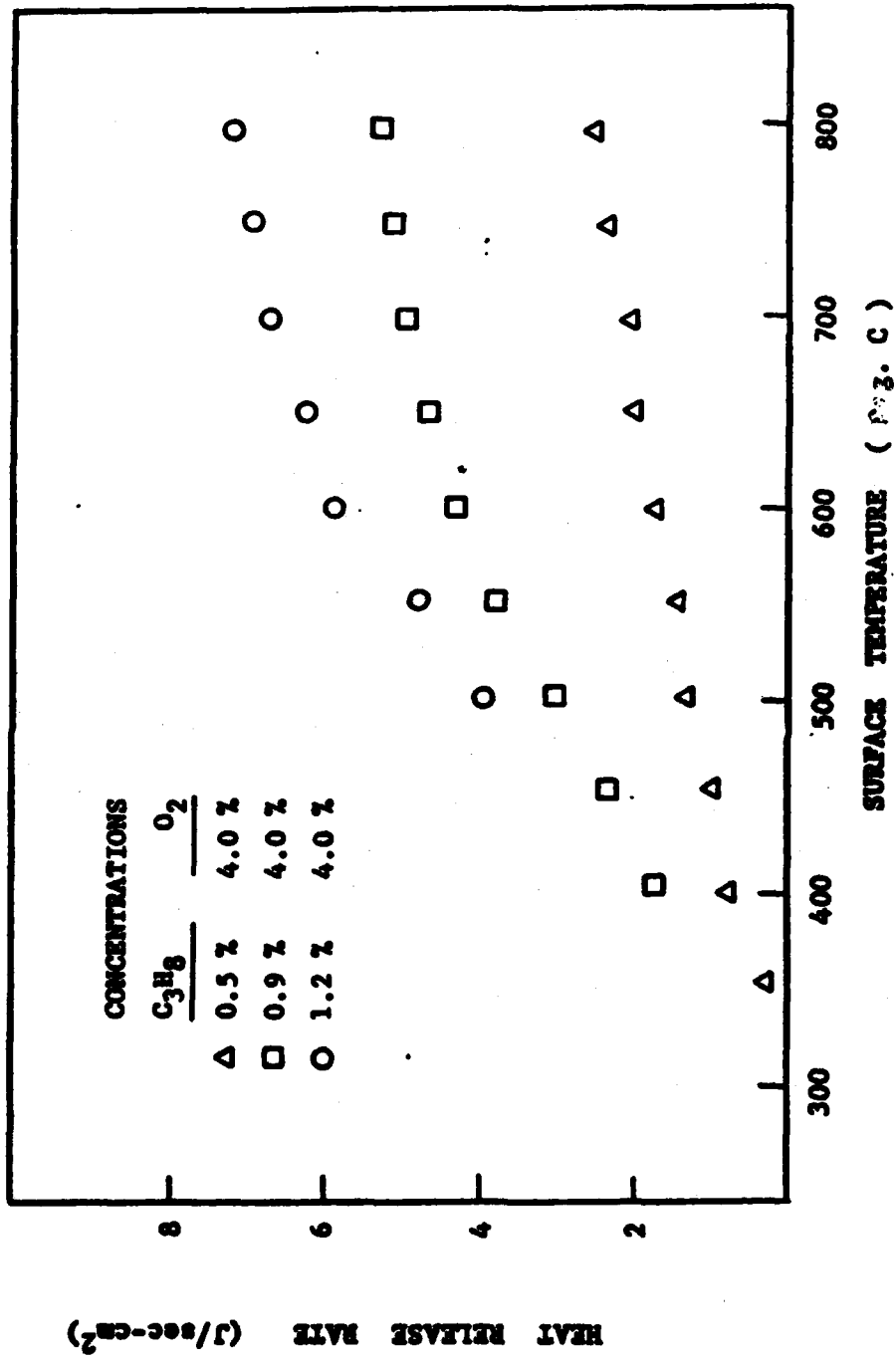

Figure 5.6(c) Heat release rate of propane/oxygen/nitrogen mixtures at constant oxygen concentrations: 4%  $O_2$ ,  $C_3H_8 \leq 1.15$

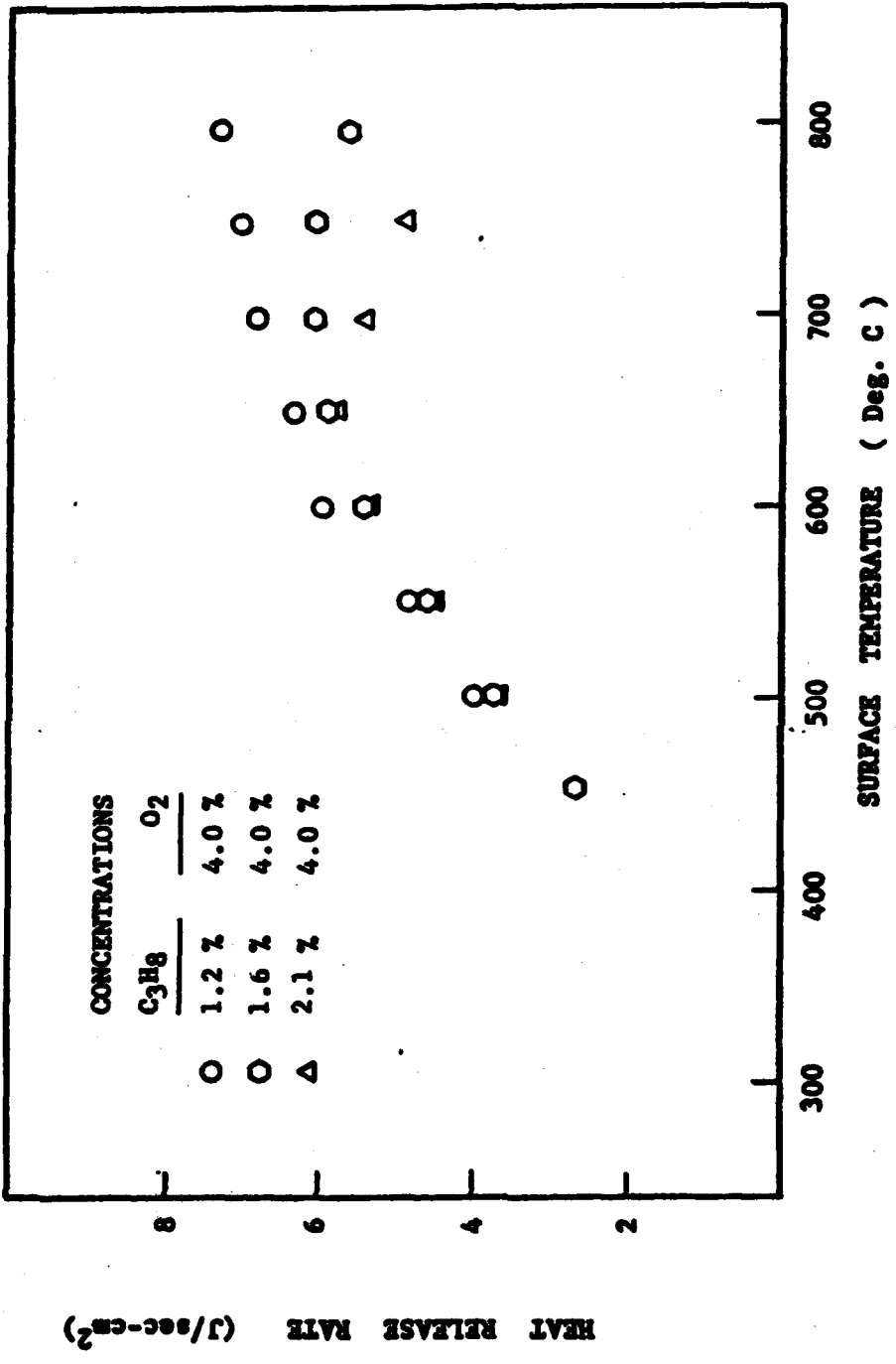

Figure 5.6(d) Heat release rate of propane/oxygen/nitrogen mixtures at constant oxygen concentrations: 4% O<sub>2</sub>, C<sub>3</sub>H<sub>8</sub> > 1.5

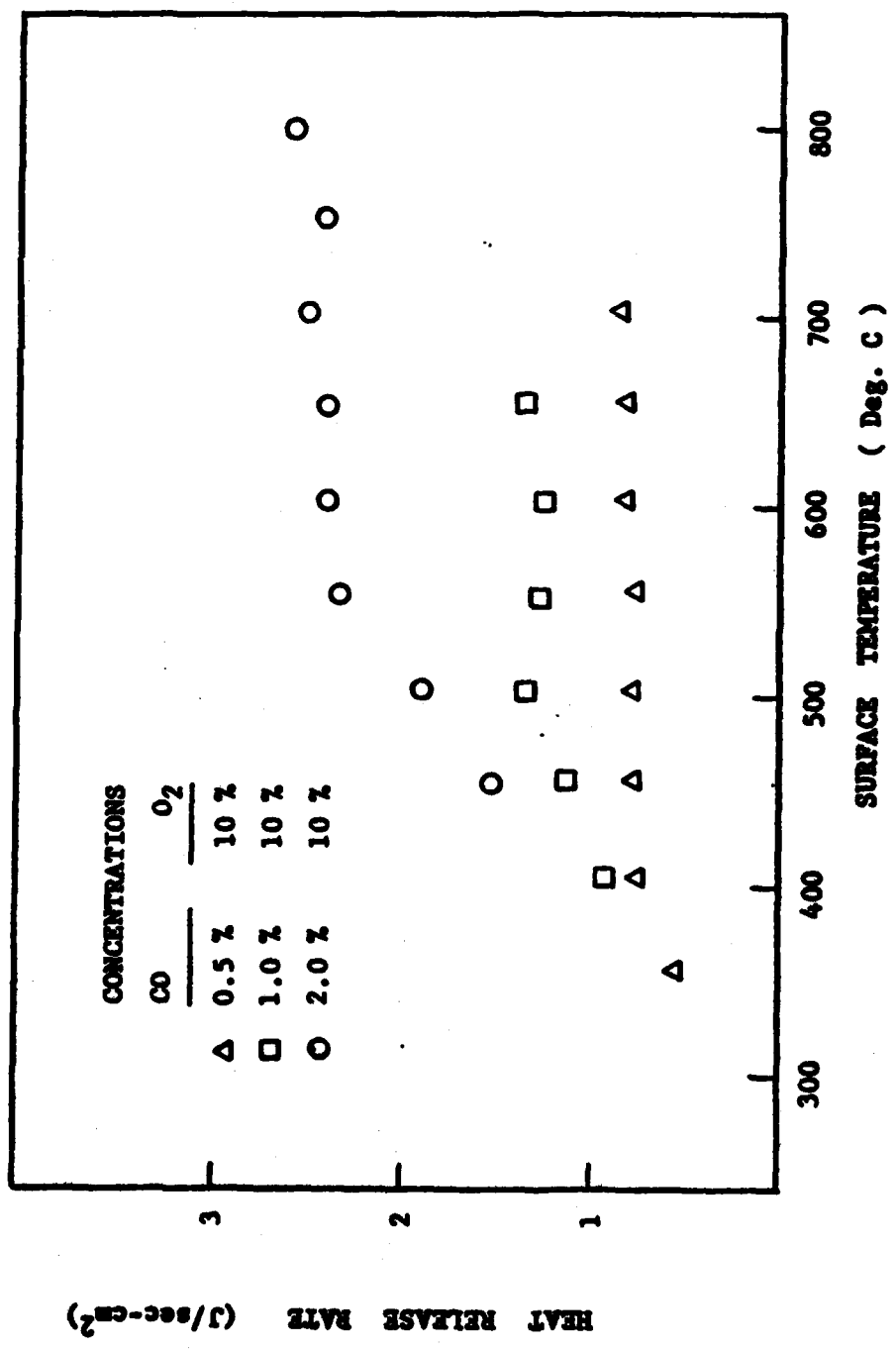

Figure 5.7(a) Heat release rate of carbon monoxide/oxygen/nitrogen mixtures at constant oxygen concentrations: 10% O<sub>2</sub>

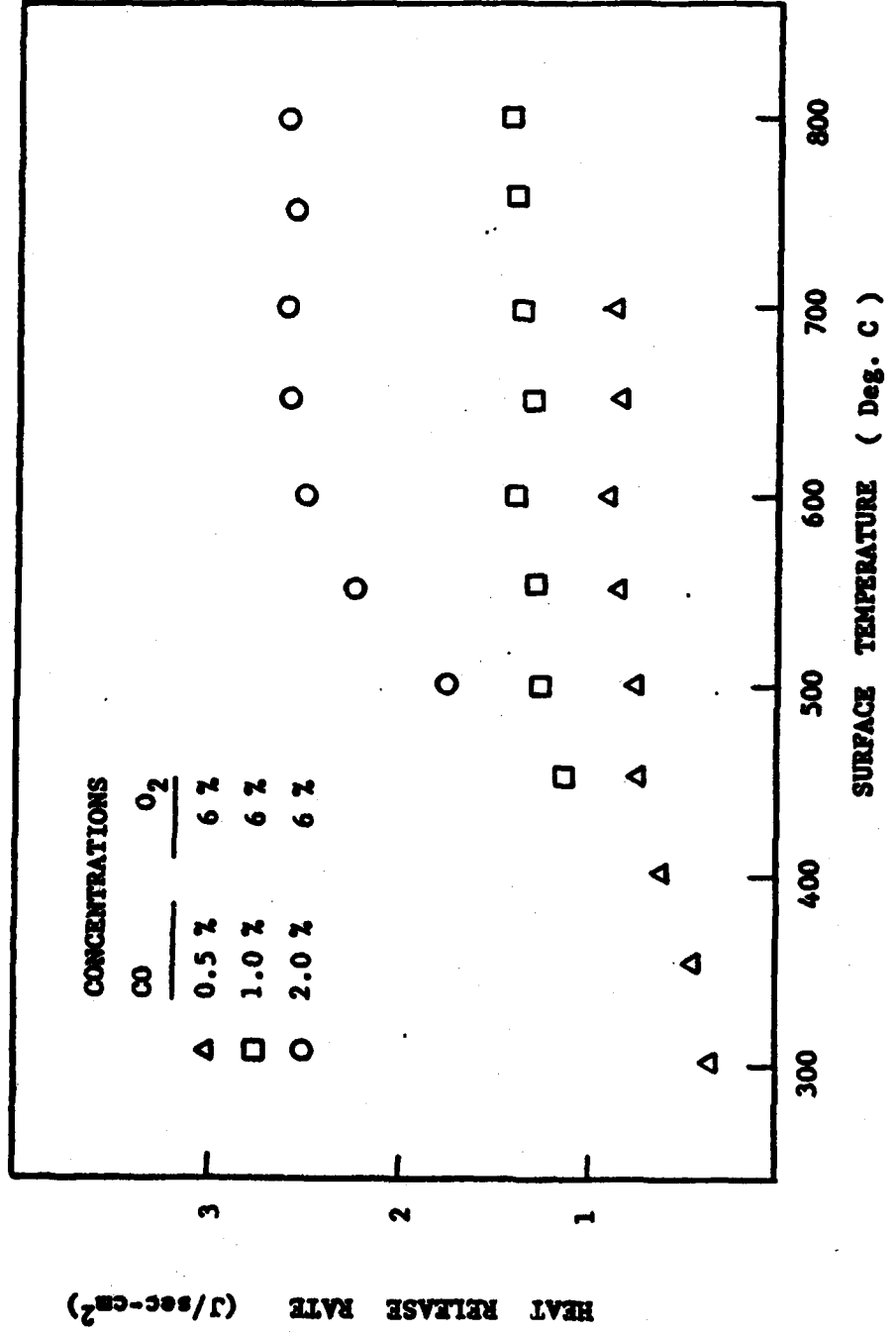

Figure 5.7(b) Heat release rate of carbon monoxide/oxygen/nitrogen mixtures at constant oxygen concentrations: 6% O<sub>2</sub>

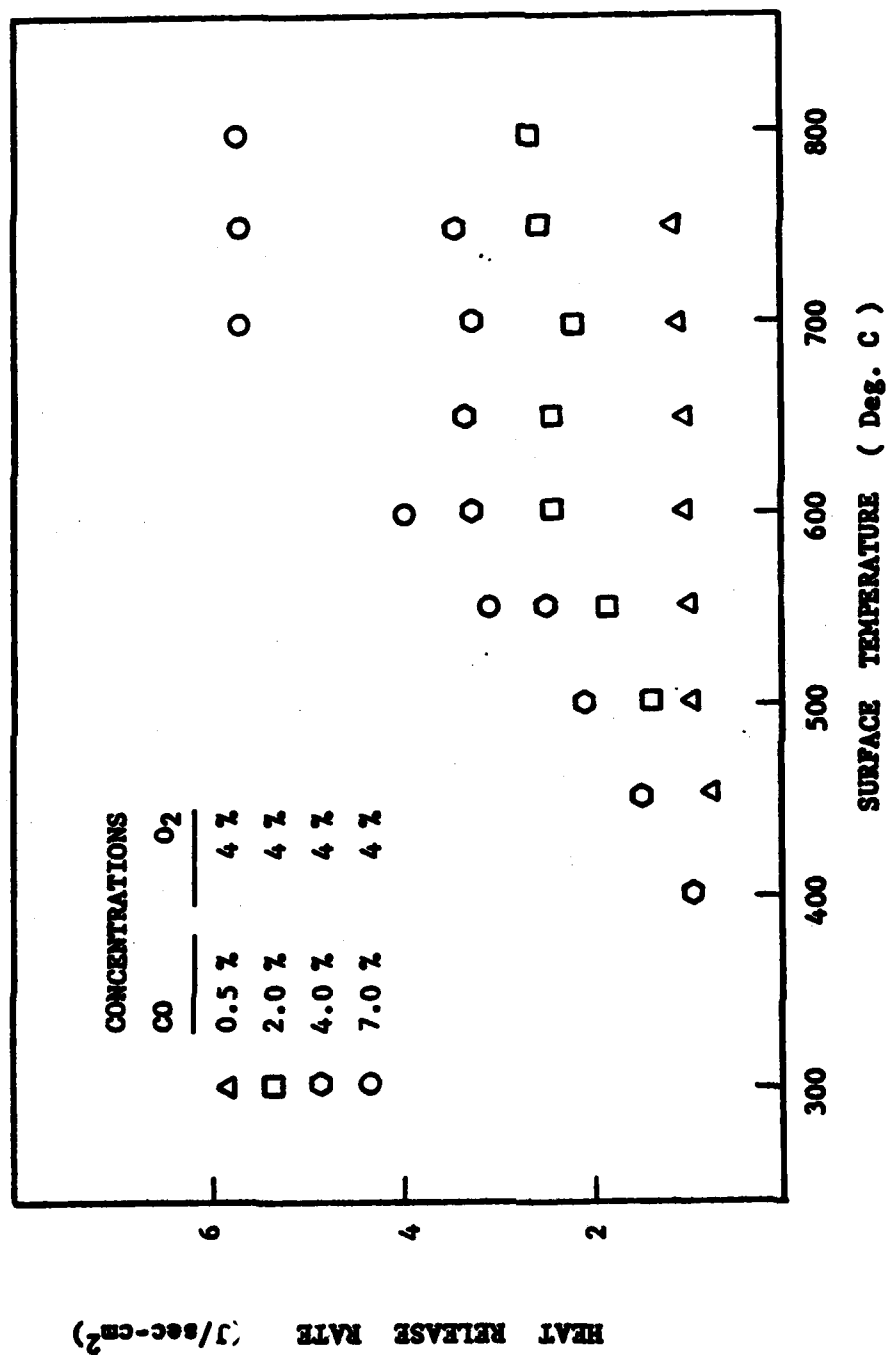

Figure 5.7(c) Heat release rate of carbon monoxide/oxygen/nitrogen mixtures at constant oxygen concentrations: 4% O<sub>2</sub>

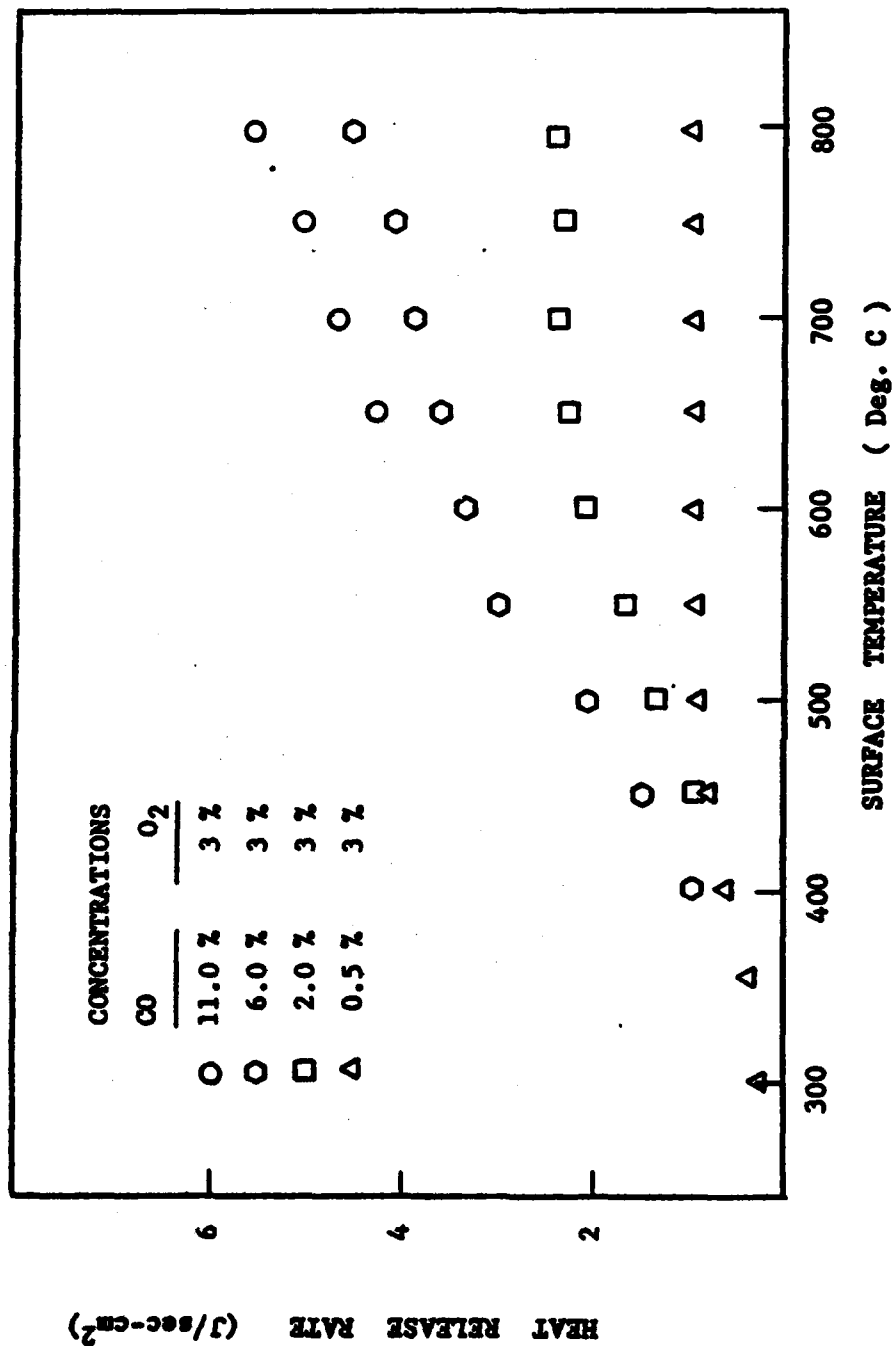

Figure 5.7(d) Heat release rate of carbon monoxide/oxygen/nitrogen mixtures at constant oxygen concentrations: 3% O<sub>2</sub>

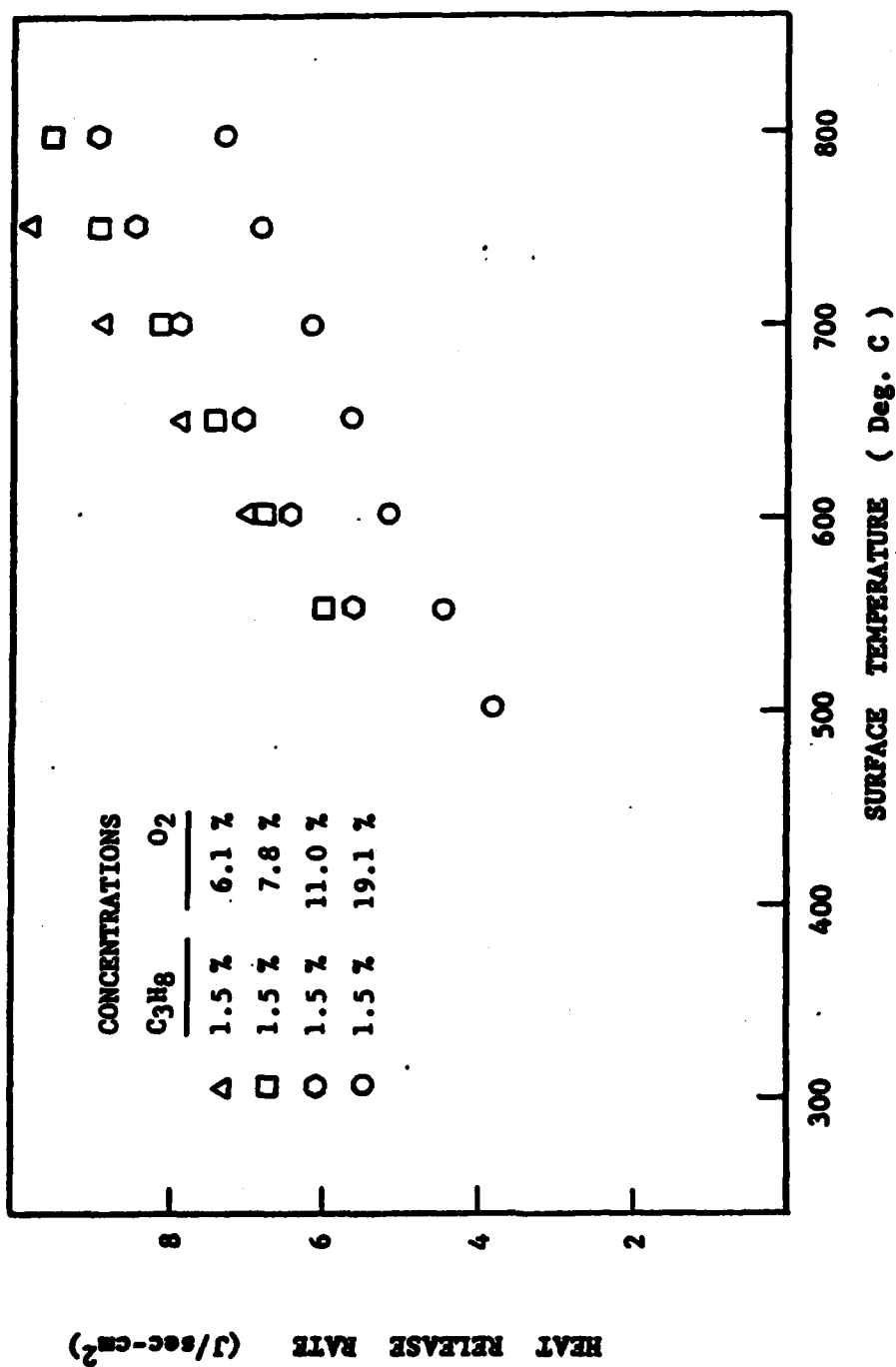

Figure 5.8(a) Heat release rate of propane/oxygen/nitrogen mixtures at constant propane concentrations: 0.5% C<sub>3</sub>H<sub>8</sub>

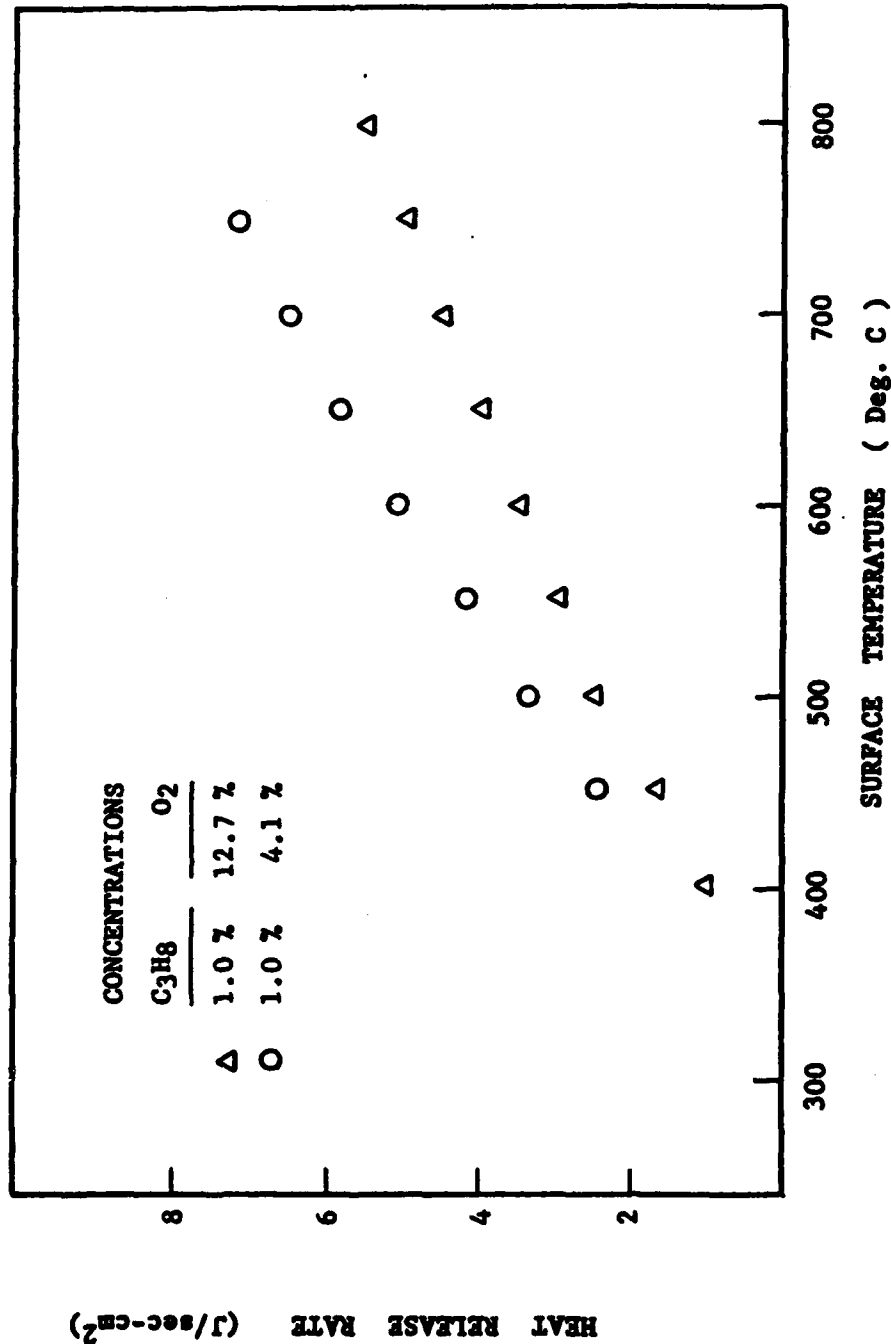

Figure 5.8(b) Heat release rate of propane/oxygen/nitrogen mixtures at constant propane concentrations: 1.0% C<sub>3</sub>H<sub>8</sub>

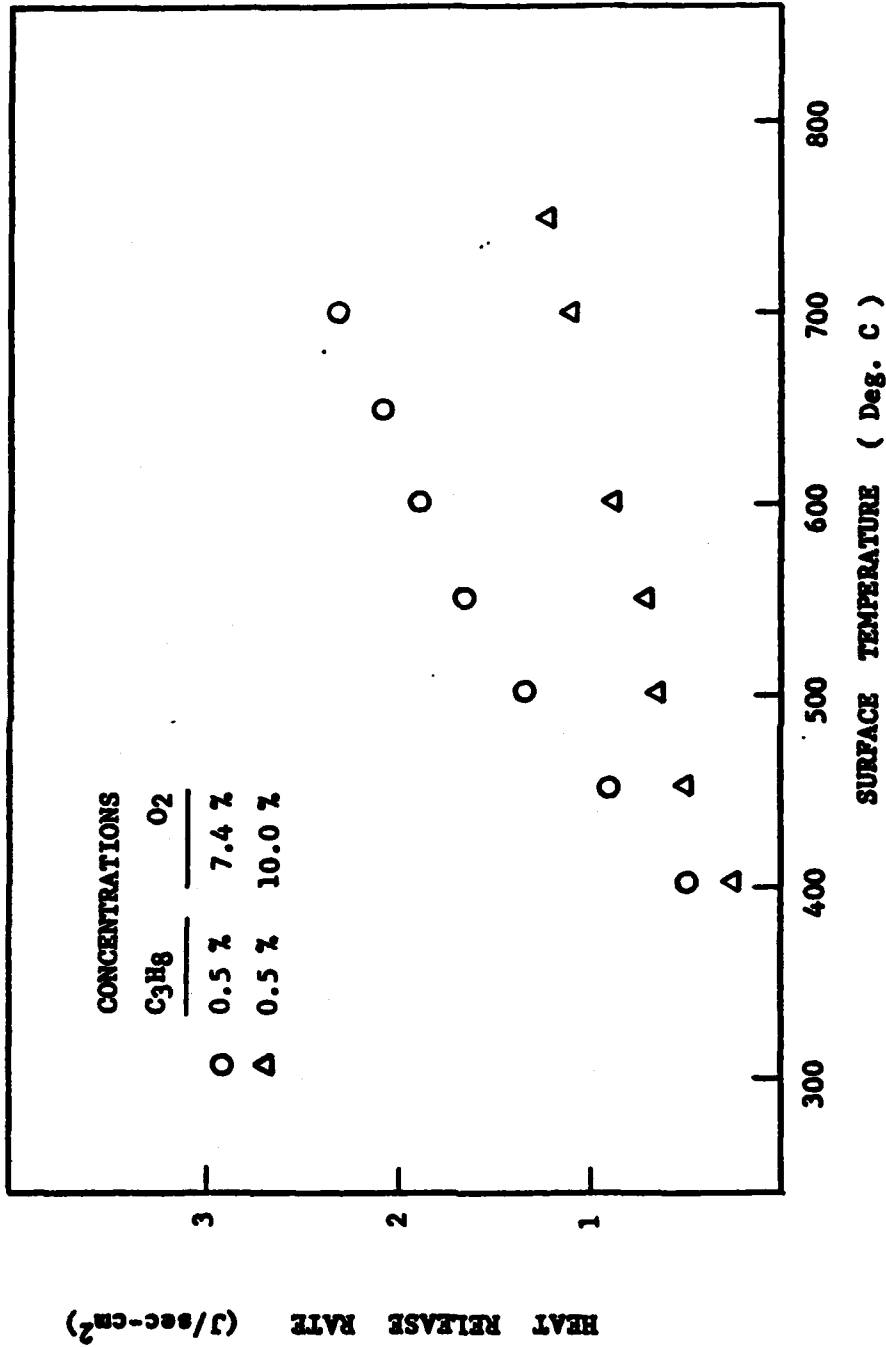

Figure 5.8(c) Heat release rate of propane/oxygen/nitrogen mixtures at constant propane concentrations: 1.5% C<sub>3</sub>H<sub>8</sub>

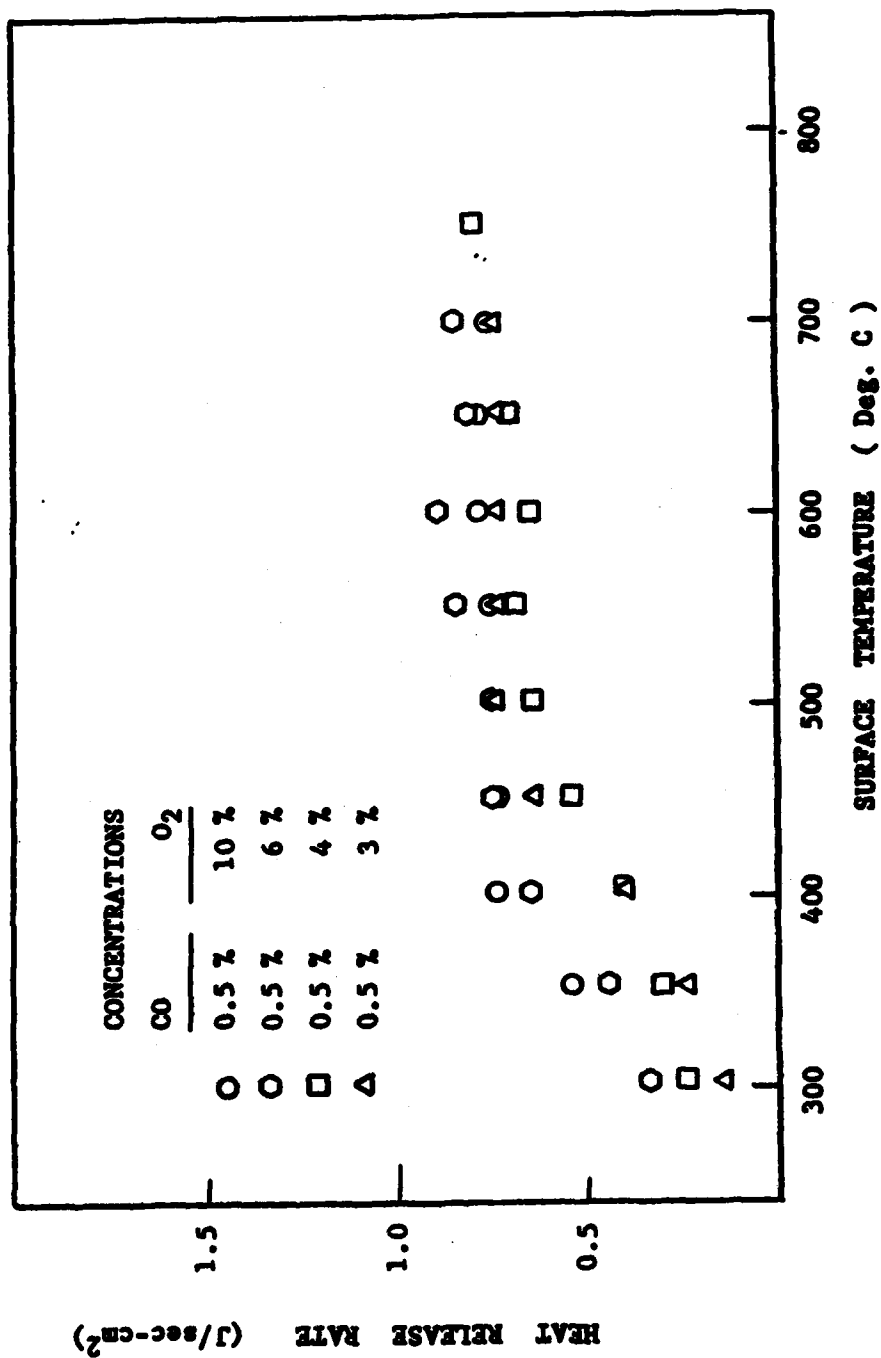

Figure 5.9(a) Heat release rate of carbon monoxide/oxygen/nitrogen mixtures at constant carbon monoxide concentrations: 0.5% CO

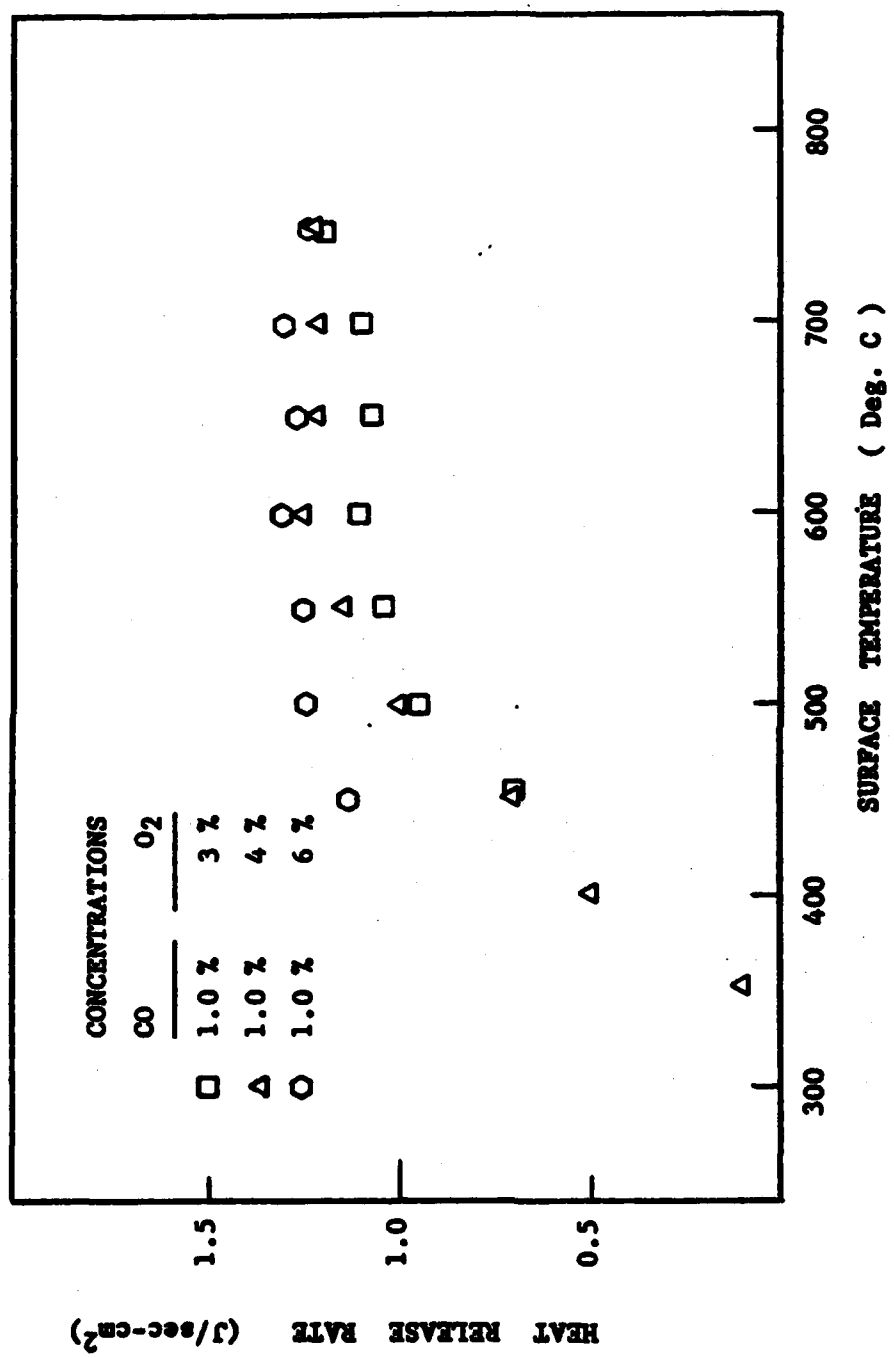

Figure 5.9(b) Heat release rate of carbon monoxide/oxygen/nitrogen mixtures at constant carbon monoxide concentrations: 1.0% CO

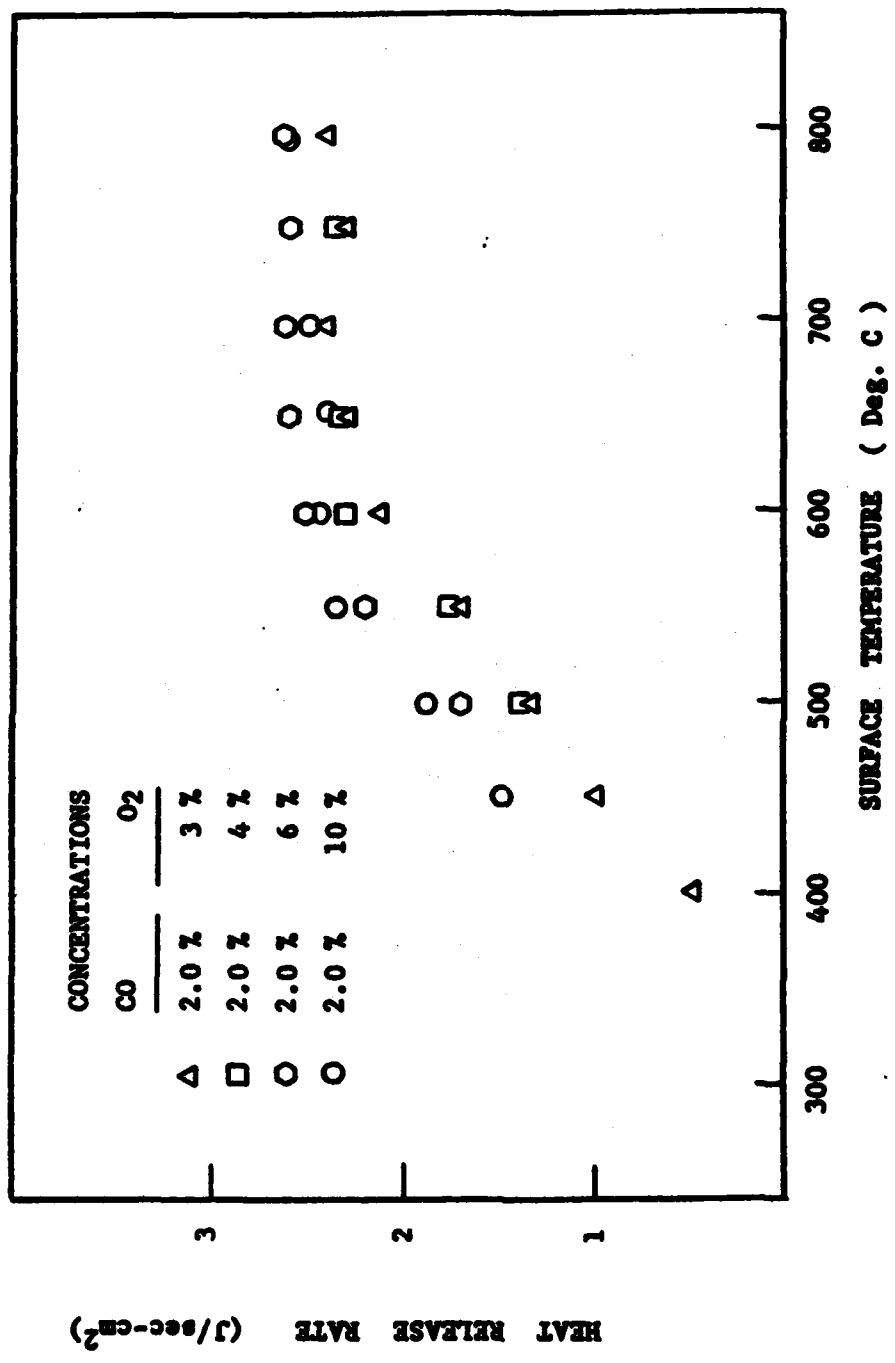

Figure 5.9(c) Heat release rate of carbon monoxide/oxygen/nitrogen mixtures at constant carbon monoxide concentrations: 2.0% CO

the mass transport is exclusively by diffusion, the reactants are equally distributed over the wire surface. However the overall reactant concentration do not remain constant as the reactants are used up at the surface. The net result is a reaction rate that is time-dependent.

On the other side, when there is a continuous supply of fresh mixture directed to the catalyst the concentration profile in the vicinity of wire remains steady with time. However, the reactant arriving at the surface moves along the wire surface as it undergoes chemical reaction. Then each reactant experiences a different reaction history depending on the nature of boundary layer formed over the surface. The axisymmetry of the reactant concentration profile is lost and the reaction rate is essentially that of evolutionary type in the same category as the flat-plate flow.

In the previous discussion concerning the flow field around the catalyst (Section 3.1.3) the flow over a thin wire is considered as an example of steady state processes in the limit of low Reynolds number. This assumption can be made if the flow velocity is not an important factor that influences the ignition behavior and the chemical reactivity of the system. Its influence on the ignition temperature is found to be negligible in both propane/air and hydrogen/air mixtures for the flow velocity considered here. That is, the velocity ranging from 5 to 20 cm/sec do not alter the ignition temperatures. The details are reported in Section 4.5.1.

The velocity does affect the heat release rates but to a different extent for different gas mixtures. For example, Fig. 5.10 shows that

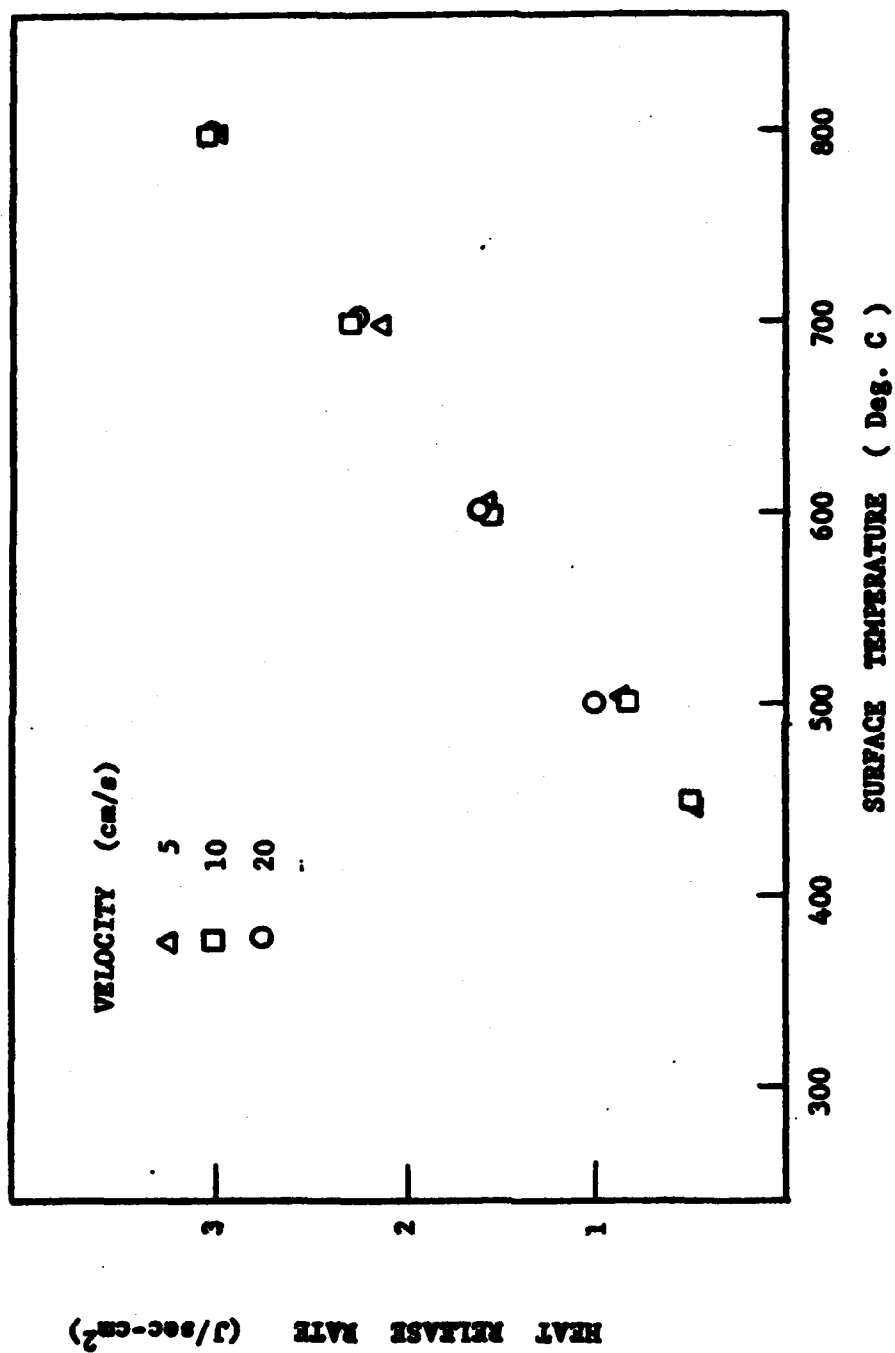

Figure 5.10(a) Effect of velocity on the heat release rates: Propane/air mixture with 1.0% C<sub>3</sub>H<sub>8</sub>

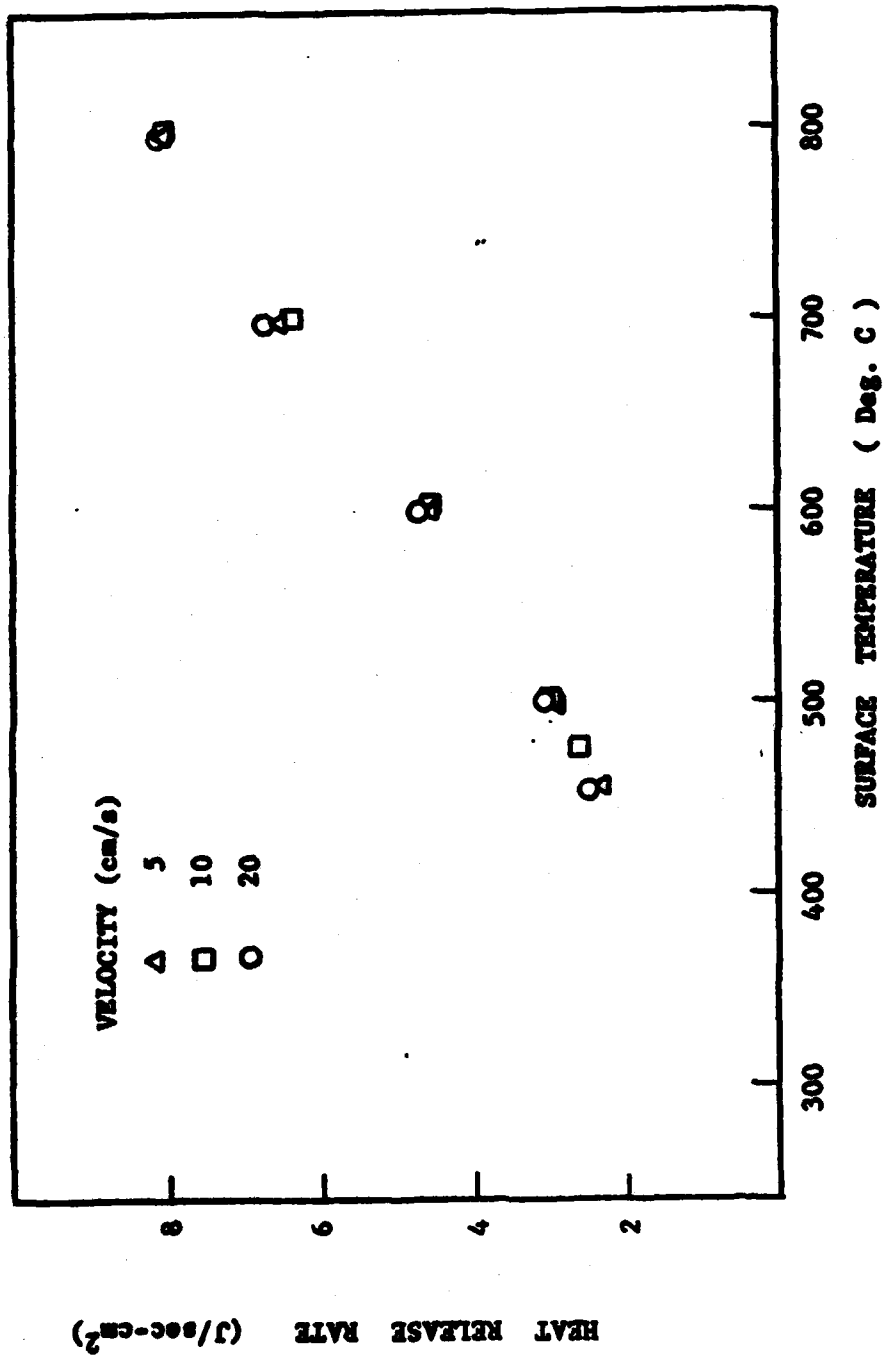

Figure 5.10(b) Effect of velocity on the heat release rates: Propane/air mixture with 2.0% C<sub>3</sub>H<sub>8</sub>

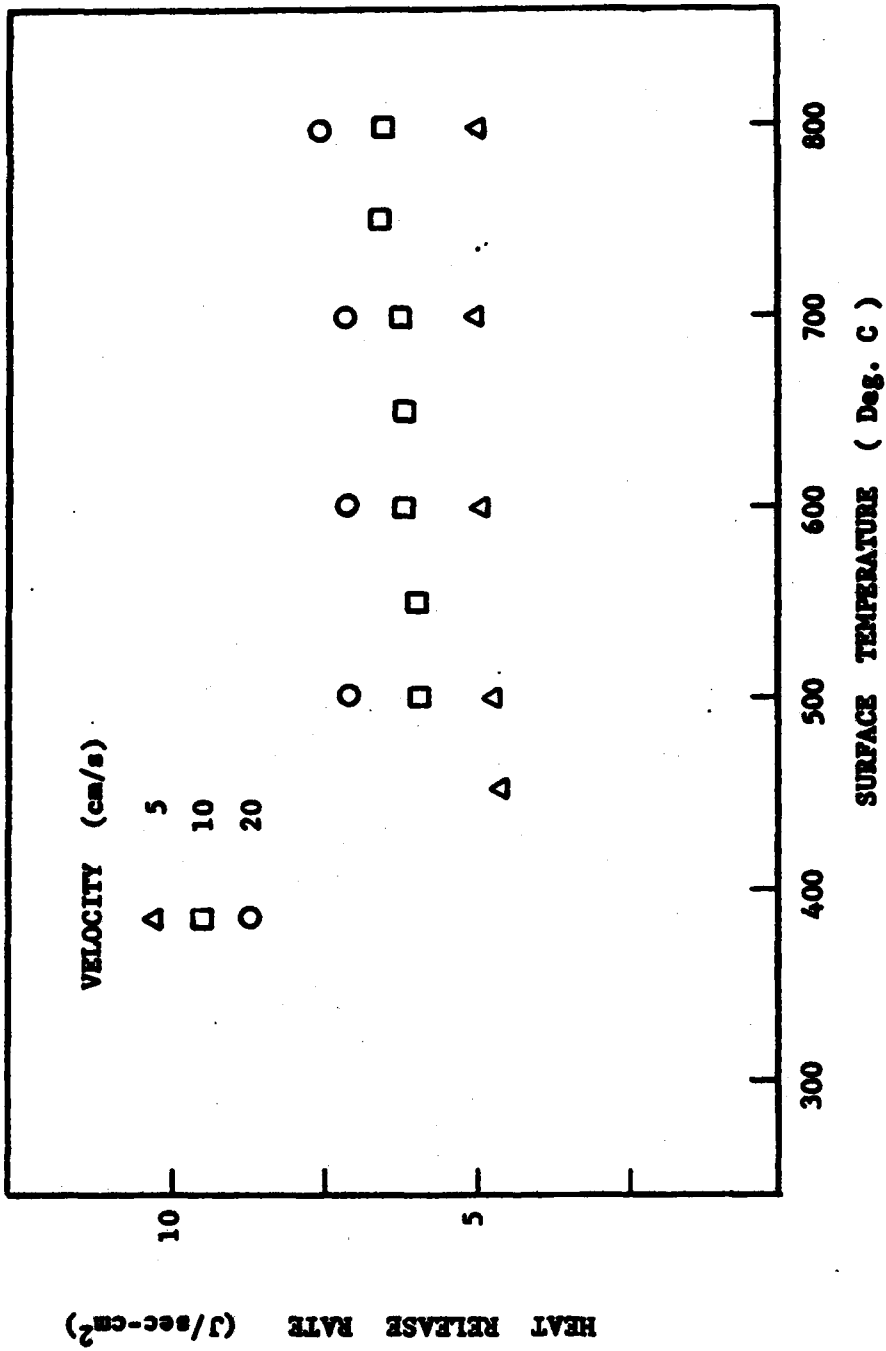

Figure 5.10(c) Effect of velocity on the heat release rates: Hydrogen/air mixture with 2.5% H<sub>2</sub>

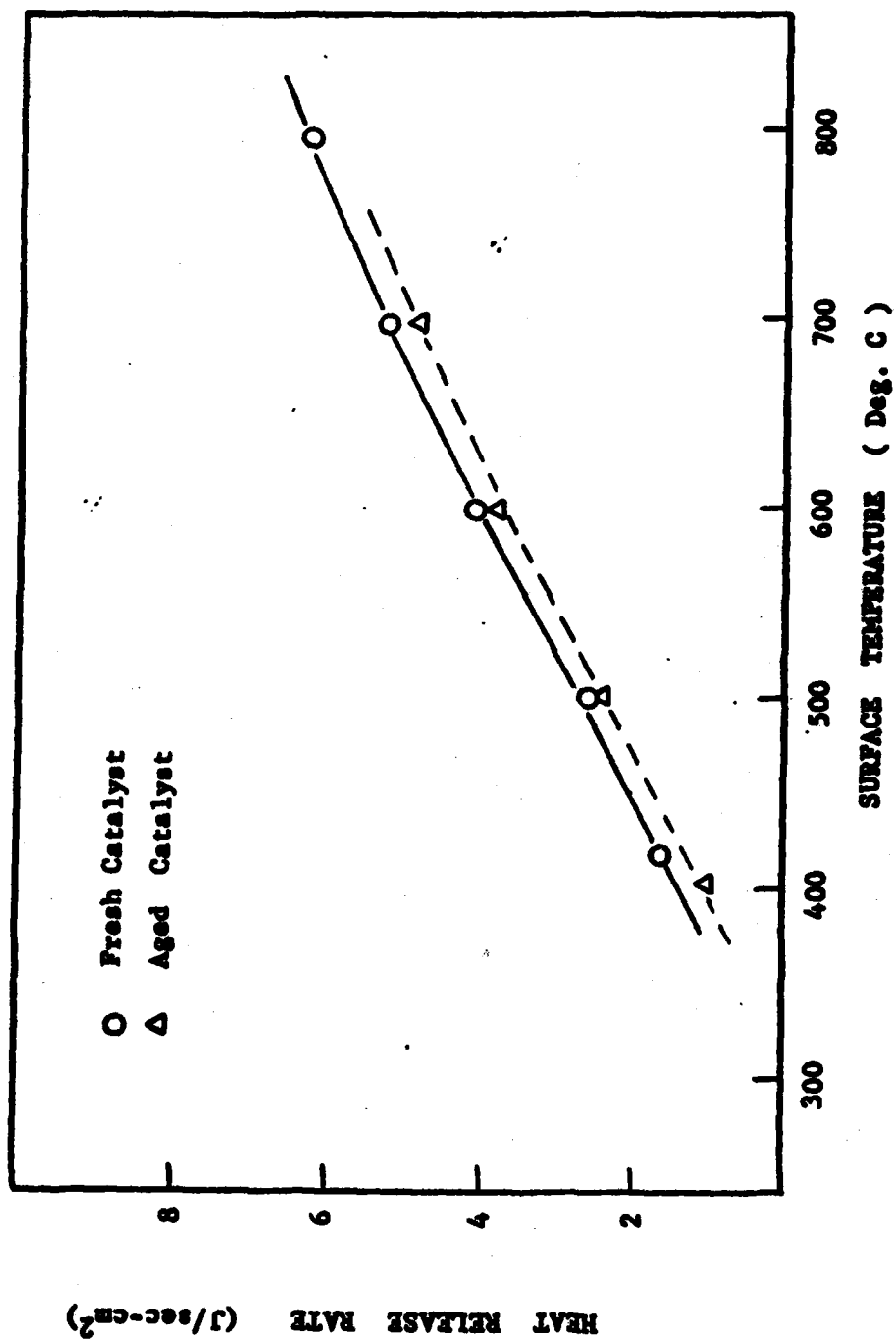

Figure 5.11(a) Effect of aging on the heat release rates: Propane/air mixtures

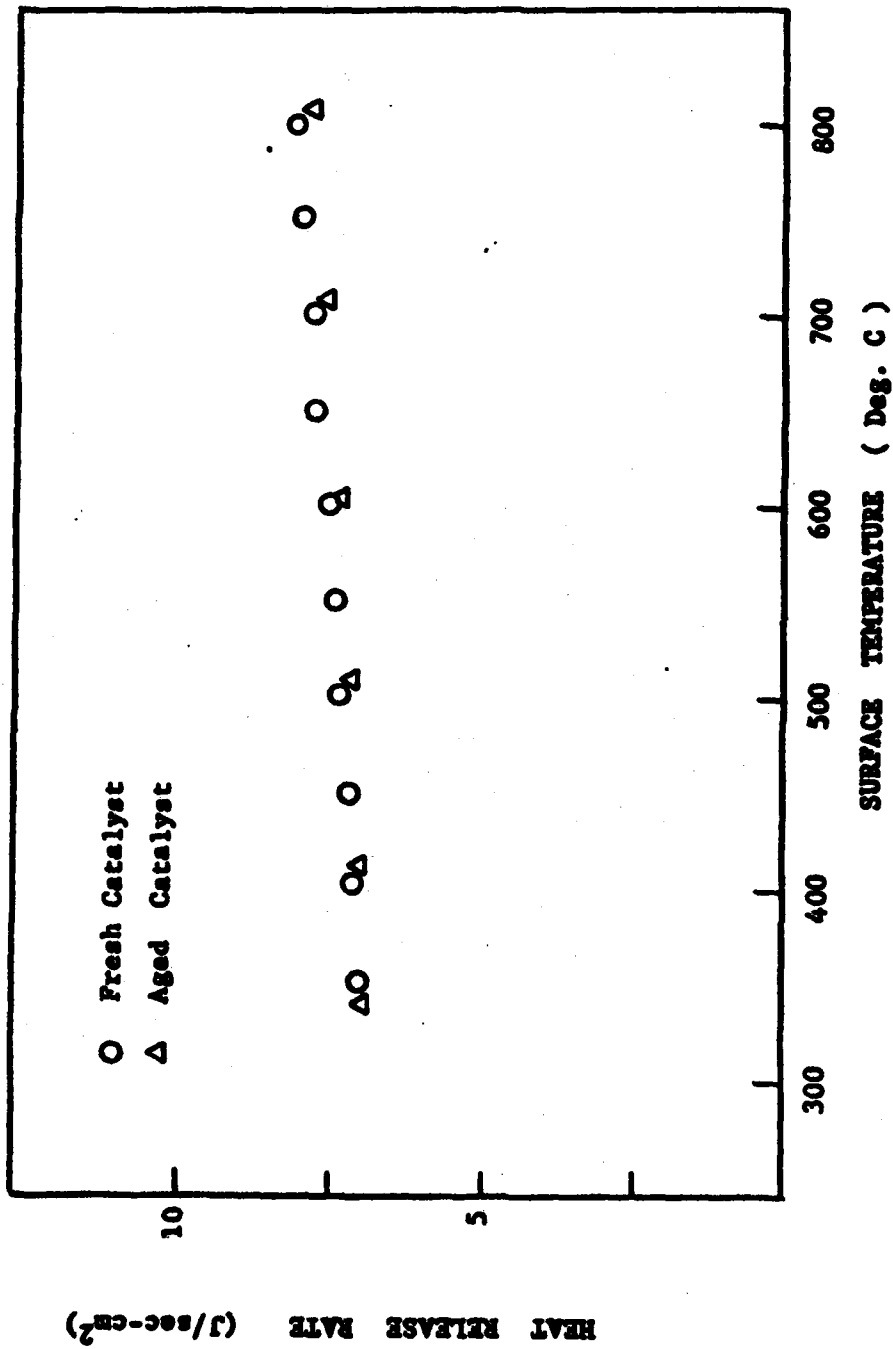

Figure 5.11(b) Effect of aging on the heat release rates: Hydrogen/air mixtures

hydrogen/air mixture released more heat as the flow velocity is increased whereas no change is observed for propane/air mixtures. The difference in their behavior is another proof that the reaction of hydrogen/air is diffusion limited such that improving the mass transport process would enhance its reaction rate and that the reaction of propane/air is kinetically controlled.

The above result supports that the catalytic wire can be considered to be immersed in a constant concentration bath up to the point of ignition for all fuel/air mixtures tested. After ignition the steady state assumption holds only for the reaction that is kinetically controlled.

The effect of aging is not a problem to the heat release rate. In contrast to the ignition temperature which is very sensitive to the history of catalyst, the heat release rates for both propane/air and hydrogen/air mixture is not too adversely affected due to repeated usage. Figure 5.11 shows some decrease in the reactivity for propane/air mixtures but almost no decline in its reactivity for hydrogen/air mixtures.

#### 5.4 SUMMARY

The heat release rates are measured for the fuel/air mixtures of propane, butane, propylene, carbon monoxide and hydrogen. A more detailed study is conducted with fuel/oxygen/nitrogen mixtures of propane and carbon monoxide. Specifically, the effect of fuel and oxygen concentration, flow velocity and aging are studied.

A wide variety of trends are observed. In one end, the propane/air mixtures show the kinetically controlled reaction rates while, in the other extreme, hydrogen/air reactions are completely diffusion limited. The other gases show the reaction that is diffusion controlled only at high temperature.

The effect of velocity on the heat release rates shows that the steady state assumption can be applied for the reactions in the kinetically controlled regime but not in the diffusion limited regime.

## CHAPTER 6

### CONCLUSIONS AND RECOMMENDATIONS

The following summarizes the work done in the present investigation of catalytic ignition and heat release of fuel/oxygen/nitrogen mixtures:

- 1) An original experimental set-up is designed and constructed. The experimental set-up includes an elaborate flow system to provide a steady flow of a completely heterogeneous mixture, an electronic system for the catalyst heater/sensor unit, and a computer system for data acquisition and processing.
- 2) The experimental methodology adopted here is based on isothermal microcalorimetry but is greatly improved by incorporating automatic feedback control unit such that both the sensitivity and the time response of the microcalorimeter is enhanced.
- 3) The modified microcalorimeter is examined extensively in order to characterize the performance accurately.
- 4) The effect of flow velocity on ignition temperature and heat release rates are studied to examine the applicability of steady state assumption for the catalyst in a wire geometry. The result indicates that the behaviors associated with kinetically controlled regime are independent of flow velocity. Specifically, the ignition temperature of fuel/air mixtures are not affected by the flow velocity if the Reynolds number is very small ( $Re < 1$ ). However, the heat release rate of a reaction in the diffusion limited regime is increased by increasing flow velocity.
- 5) Ignition temperatures of propane, butane, propylene, ethylene,

carbon monoxide and hydrogen are mapped as a function of fuel concentrations. Two opposing trends are observed. The ignition temperature of propane and butane decreases as their concentration is increased. However, the reverse trend is observed for propylene, ethylene, carbon monoxide and hydrogen. The difference in the trend is explained from their chemisorption strength relative to oxygen. The preferential adsorption of oxygen in the case of propane and butane oxidation is compared to the competitive chemisorption of the reactants for the other gases.

- 6) The study to show the dependence of ignition and the heat release rate on fuel concentration is extended from fuel lean to rich cases by diluting the mixture with nitrogen to suppress gas-phase ignition. The result shows that the trend observed for fuel/air mixtures is continued even for the mixtures that are very rich in fuel.
- 7) The effect of oxygen concentration on the ignition temperature and heat release rates is also studied for propane and carbon monoxide. The ignition temperature shows a minimum on the lean side of stoichiometry for propane but, for carbon monoxide, it decreases monotonically with increase in oxygen concentration.

While the present investigation has provided many useful insights into the catalytic ignition and heat release rates of simple fuels it has identified several important problems which require further investigation. The major ones are listed in the following.

- 1) A study of the pressure effect is important from practical point of

view because most combustors frequently operate with pressures in excess of atmospheric. From the fundamental viewpoint it is reasonable to expect that kinetic rates and mechanisms will change with increasing pressure because of the increased molecular collision frequency as well as the different extents to which catalytic surface is populated with different species. Thus existing kinetic data may not be readily applicable to high pressure situations.

- 2) Low pressure study is also needed since the most of the data on the catalytic behavior at the molecular level is conducted at low vacuum conditions.
- 3) The second factor is the multicomponent nature of practical fuels, especially alternate or non-specification fuels. Obviously one would not expect their kinetic behavior to scale in any simple manner with the species composition. Certain active species may dominate the combustion and heat transfer characteristics even if their concentrations are reduced to very low levels.

## REFERENCES

- Ablow, C. M., and Wise, H., "Theoretical Analysis of Catalytic Combustion in a Monolithic Reaction," *Combust. Sci. Tech.*, 21, pp. 35-42, (1979).
- Ablow, C. M., Schechter, S., and Wise, H., "Catalytic Combustion in a Stagnation Point Boundary Layer," *Combust. Sci. Tech.*, 22, pp. 107-117, (1980).
- Beck, O., "Hydrogenation Catalysts," *Disc. Faraday Soc.*, 8, pp. 118-128, (1950).
- Bensalem, O., and Ernst, W. R., "Mathematical Modeling of Homogeneous-Heterogeneous Reactions in Monolithic Catalysts," *Combust. Sci. Tech.*, 29, pp. 1-13, (1982).
- Bond, G. C., "Adsorption and Co-ordination of Unsaturated Hydrocarbons with Metal Surfaces and Metal Atoms," *Disc. Farad. Soc.*, 41, p. 200, (1966).
- Bond, G. C., Heterogeneous Catalysis: Principles and Applications, Clarendon Press: Oxford, 1974.
- Boraskov, G. K., "Forms of Oxygen Bonds on the Surface of Oxidation Catalysts," *Disc. Farad. Soc.*, 41, pp. 263-276, (1966).
- Buben, N., "A Method of Determination of the Kinetic Characteristics of a Heterogeneous Exothermic Reaction," *Zhur, Fiz. Khim.*, 19, p. 250, (1945).
- Cairnie, L. R., Harrison, A. J., and Morgan, P.A., "Autoignition in a Free Convection Boundary Layer," Eighteenth Symposium (International) on Combustion, The Combustion Institute, pp. 1799-1806, (1981).
- Cardoso, M. A. A., and Luss, D., "Stability of Catalytic Wires," *Chem. Eng. Sci.*, pp. 1699-1710, (1969).
- Coward, H. F., and Guest, P. G., "Ignition of Natural-Gas-Air Mixtures by Heated Metal Bars," *J. Am. Chem. Soc.*, 49, pp. 2479-2486, (1927).
- Cullis, C. F., "Heterogeneous Catalytic Oxidation of Hydrocarbons," *ICEC*, pp. 18-27, (Dec. 1967).
- Cullis, C. F., Neveill, T. G. and Trimm, D. L., "Measurement of the Rates of Heterogeneous Catalytic Reaction Using a Calorimetric Bead System," *J. Phys. E.: Scientific Instrum.*, 6, pp. 384-388 (1973).

- Drauglis, E., and Jaffee, R. I., (eds.), The Physical Basis for Heterogeneous Catalysis, Plenum Press: N.Y., 1975.
- Edwards, W. M., Worley, Jr., F. L., and Luss, D., "Temperature Fluctuations (Flickering) of Catalytic Wires and Gauzes — II. Experimental Study of Butane Oxidation on Platinum Wires," *Chem. Eng. Sci.*, 28, pp. 1479-1491, (1973).
- Engel, T., and Ertl, G., "Elementary Steps in the Catalytic Oxidation of Carbon Monoxide on Platinum Metals," *Advan. Catalysis*, 28, pp. 1-77, (1979).
- Firth, J. G., "Catalytic Oxidation of Methane on Palladium - Gold Alloys," *Trans. Farad. Soc.*, 52, pp. 2566-2576, (1966).
- Frank-Kamenetskii, D. A., Diffusion and Heat Exchange in Chemical Kinetics, Princeton Univ. Press: Princeton, N. J., (1955).
- Frennet, A., "Chemisorption and Exchange with Deuterium of Methane on Metals," *Cat. Rev. — Sci. Eng.*, 10(1), pp. 37-68, (1974).
- Freyruth, P., "Feedback Control Theory for Constant-Temperature Hot-Wire Anemometer," *The Rev. Sci. Instrum.*, pp. 677-681, (May 1967).
- Galway, A. K., "Compensation Effect in Heterogeneous Catalysis," *Advan. Catalysis*, 26, pp. 247-322, (1977).
- Gentry, S. J., Firth, J. G., and Jones, A., "Catalytic Oxidation of Hydrogen over Platinum," *J. Chem. Soc. Faraday I*, 70, pp. 600-604, (1974).
- Glassman, I., Combustion, Academic Press: N. Y., 1977.
- Gravelle, P. C., "Heat-Flow Microcalorimetry and Its Applications to Heterogeneous Catalysis," *Advanc. Catalysis*, 22, (1972).
- Gray, B. F., "The Unified theory of Explosions with Fuel Consumption," *Seventeenth Symposium (International) on Combustion*, p. 927, (1979).
- Gray, R., Griffiths, J. F., and Rogerson, J. S., "Instabilities in the Exothermic Oxidation of Carbon Monoxide on a Platinum Surface," *ASME 79-HT-56*, presented at the Joint ASME/AICHE 18th Nat. Heat Transfer Conf. San Diego, Aug. 6-8, (1979).
- Guczi, L., and Karpinski, Z., "Catalytic Reactions of Hydrocarbons over Pt - Pd Alloys II. Deuterium Exchange of Methane and Ethane over Pt - Pd Alloys Films. Surface Composition of Pt - Pd Alloy System," *J. Catalysis*, 56, pp. 438-444, (1979).

- Halstead, M. P., Kirsch, L. J., Protharo, A., and Quinn, C. P., "A Mathematical Model for Hydrocarbon Autoignition at High Pressures," *Proc. Roy Soc. Lond. A.*, 346, pp. 515-538, (1975).
- Hanson, F. V., and Boudart, M., "The Reaction Between  $H_2$  and  $O_2$  Over Supported Platinum Catalysts," *J. Catalysis*, 53, pp. 56-67, (1978).
- Hautmann, D. J., Dryer, F. L., Schug, K. P., and Glassman, I., "A Multiple-step Overall Kinetic Mechanism for the Oxidation of Hydrocarbons," *Combust. Sci. Tech.*, 25, pp. 219-235, (1981).
- Hayne, H., and Tompkins, F. C., "Application of Infrared Spectroscopy and Surface Potential Measurements in a Study of the Oxidation of Carbon Monoxide on Platinum," *Proc. Roy Soc.*, 292, pp. 460-478, (1966).
- Hiam, L., Wise, H., and Chaikin, S., "Catalytic Oxidation of Hydrocarbons on Platinum," *J. Catalysis*, 10, pp. 272-276, (1968).
- Hlavacek, V., and Votruba, J., "Hysteresis and Periodic Activity Behavior in Catalytic Chemical Reaction Systems," *Advan. Catalysis*, 27, pp. 59-96, (1978).
- Jones, A., Firth, J. G., and Jones, T. A., "Calorimetric Bead Techniques for the Measurement of Kinetic Data for Gas-Solid Heterogeneous Reactions," *J. Phys. E: Sci. Instrum.*, 8, pp. 37-40, (1975).
- Kanury, A. M., Introduction to Combustion Phenomena, Gordon and Breach Science Publishers: N.Y., 1975.
- Kasemo, B., and Kock, K-E., "A Fast Response, Local Gas-Sampling System for Studies of Catalytic Reactions at  $1-10^3$  Torr; Application to the  $H_2D_2$  Exchange and  $H_2$  Oxidation Reactions on Pt.," *J. Catalysis*, 66, pp. 441-450, (1980).
- Kaufman, F., "Chemical Kinetics and Combustion: Intricate Paths and Simple Steps," Nineteenth Symposium (International) on Combustion, The Combustion Institute, pp. 1-10, (1982).
- Kemball, C., "The Structure and Stability of Hydrocarbon Intermediates on the Surface of Catalysts," *Catalysis Rev.*, 5(1), pp. 33-54, (1971).
- Kemball, C., and Patterson, W. R., "The Catalytic Oxidation of Ethylene on Palladium Films," *Proc. Roy Soc. A* 270, p. 219, (1962).
- Kirchhoff, R. H., and Strusiak, R. M., "Direct Measurement of the Mean Flow Velocity Vector," *Trans. ASME*, pp. 736-739, (Dec. 1976).

- Krebs, H. J., Bonzel, H. P., and Garner, G., "A Model Study of the Hydrogenation of CO Over Polycrystalline Iron," *Surface Sci.*, 88, p. 269, (1979).
- Krill, W. V., Kesselring, J. P., Chu, E. K., and Kendall, R. M., "Catalytic Combustion for System Application," ASME paper No. 79-HT-54, (1979).
- Law, C. K., "Catalytic Combustion in a Shear Flow," Fifth Workshop on Catalytic Combustion, San Antonio, Texas, Sept. 15-16, (1981).
- Law, C. K. and Chung, S. H., "Thermal and Catalytic Inhibition of Ignition Through Reactant Depletion," *Combust. Sci. Tech.*, 32, pp. 307-312, (1983).
- Lewis, B., and von Elbe, G., Combustion, Flame and Explosions of Gases, Academic Press: N.Y., 1961.
- Linan, A. and Williams, F. A., "Note on Ignition by a Hot Catalytic Surface," *SIAM J. Appl. Math.* 40(2), (1981).
- Lovachev, L. A., "Chemical Kinetics in Flames - A Review," *Combust. Sci. Tech.*, 25, pp. 49-69, (1981).
- Margolis, L. YA., "Catalytic Oxidation of Hydrocarbons," *Advan. Catalysis*, 17, pp. 429-501, (1963).
- Margolis, L. YA., "Present State of Ideas on the Mechanism of Catalytic Hydrocarbon Oxidation," *Catalysis Rev.*, 8(2), pp. 241-267, (1973).
- Martenev, P. J., and Kesten, A. S., "Kinetics of Surface Reactions in Catalytic Combustion," Eighteenth Symposium (International) on Combustion, The Combustion Institute, pp. 1899-1907, (1981).
- Miller, J. A., "A Simple Linearized Hot-Wire Anemometer," *J. Fluids Eng.*, pp. 749-750, (Dec. 1976).
- Monroe, D. R., and Merrill, R. P., "Adsorption of Oxygen on Pt. (111) and Its Reactivity to Hydrogen and Carbon Monoxide," *J. Catalysis*, 65, pp. 461-469, (1980).
- Moro-oka, Y., and Ozaki, A., "Regularities in Catalytic Properties of Metal Oxides in Propylene Oxidation," *J. Catalysis*, 5, pp. 116-124, (1966).
- Moro-oka, Y., Morikawa, Y., and Ozaki, A., "Regularity in the Catalytic Properties of Metal Oxides in Hydrocarbon Oxidation," *J. Catalysis*, 7, p. 23, (1967).

- Mummy, M. J., and Schmidt, L. D., "Surface Combustion Following High Exposure to Gases:  $C_0$ ,  $O_2$  and  $NH_3$  on Pt.," *Surface Sci.*, 91, p. 301, (1980).
- Metzer, F. P., and Kneringer, G., "The Adsorption of Hydrogen and the Reaction of Hydrogen with Oxygen on Pt. (100)," *Surface Sci.*, 51, p. 526, (1975).
- Patterson, W. R., and Kamball, C., "The Catalytic Oxidation of Olefin on Metal Films," *J. Catalysis*, 2, p. 465, (1963).
- Ponac, V., Knor, Z., and Cerny, S., "Role of Chemisorption in Simple Catalytic Reactions," *Disc. Farad. Soc.*, 41, p. 149, (1966).
- Prasad, R., Kennedy, L. A., and Ruckenstein, E., "Catalytic Combustion — A Review," To be published.
- Rader, C. G., and Weller, S. W., "Ignition on Catalytic Wires: Kinetic Parameter Determination by the Heated-Wire Technique," *AIChE J.* 20 (3), pp. 515-522, (May 1974).
- Rajadhyaksha, R. A., and Doraiswamy, L. K., "Falsification of Kinetic Parameters by Transport Limitations and Its Role in Discerning the Controlling Regime," *Catalysis Rev. — Sci. Eng.*, 13 (2), pp. 209-258, (1976).
- Robben, R., Schafer, R., Agrawal, V., and Namer, I., "Catalyzed Combustion in a Flat Plate Boundary Layer I. Experimental Measurements and Comparison with Numerical Calculations," Presented at the Fall Meeting, Western States Section of The Combustion Institute, Oct. 17-8, Stanford, California, (1977).
- Robertson, A. J. B., Catalysis of Gas Reactions by Metals, Springer-Verlag, New York Inc.: N.Y., 1970.
- Rosfjord, T. J., "Catalytic Combustors for Gas Turbine Engines," AIAA paper No. 76-46, (14th Science Meeting), (1976).
- Sachtler, W. M. H., "The Mechanism of the Catalytic Oxidation of Some Organic Molecules," *Catalysis Rev.*, 4(1), pp. 27-52, (1970).
- Satterfield, C. N. and Cortez, D. H., "Mass Transfer Characteristics of Woven-Wire Screen Catalysts," *Ind. Eng. Chem. Fundam.*, 9(4), pp. 613-620, (1970).
- Satterfield, C. N., Heterogeneous Catalysis in Practice, McGraw-Hill Book Co., 1980.

- Schefer, R., and Robben, F., "Catalyzed Combustion in a Flat Plate Boundary Layer II. Numerical Calculation," Fall Meeting of the Western States Section of The Combustion Institute, Stanford, California, (Oct. 1977).
- Schefer, R. W., Cheng, R. K., Robben, F. A., and Brown, N. J., "Catalyzed Combustion of H<sub>2</sub>/Air Mixtures on a Heated Platinum Plate," Spring Meeting of the Western States Section of The Combustion Institute, No. 78-33, (April 1978).
- Schefer, R. W., Robben, F., and Cheng, R. K., "Catalyzed Combustion of H<sub>2</sub>/Air Mixtures in a Flat-Plate Boundary Layer: I. Experimental Results," *Combustion and Flame*, 38, pp. 51-63, (1980a).
- Schefer, R. W., and Robben, F., "Catalyzed Combustion of Lean Fuel/Air Mixtures," Fourth Workshop on Catalytic Combustion, Cincinnati, Ohio, May 14-15, (1980b).
- Schefer, R. W., Brown, N. J., and Robben, F., "High Temperature Oxidation of H<sub>2</sub> on a Platinum Catalyst," to be published, (1983).
- Scheintuch, M., and Schmitz, R. A., "Oscillations in Catalytic Reactions," *Catalysis Rev. — Sci. Eng.*, 15(1), pp. 107-172, (1977).
- Schwartz, A., Holbrook, L. L., and Wise, H., "Catalytic Oxidation Studies with Platinum and Palladium," *J. Catalysis*, 21, pp. 199-207, (1971).
- Slin'ko, M. G., and Slin'ko, M. M., "Self-Oscillations of Heterogeneous Catalytic Reaction Rates," *Catalysis Rev. — Sci. Eng.*, 117(1), pp. 119-153, (1978).
- Stone, F. S., "Chemisorption and Catalysis on Metallic Oxidizer," *Advan. Catalysis*, 13(1), (1962).
- Tanaka, K., and Tamaru, K., "A General Rule in Chemisorption of Gases on Metals," *J. Catalysis*, 2, pp. 366-370, (1963).
- Thomson, S. J., and Webb, G., Heterogeneous Catalysis, John Wiley and Sons Inc.: N.Y., 1968.
- Trevino, C., and Fernandez-Pello, A. C., "Catalytic Flat Plate Boundary Layer Ignition," *Combust. Sci. Tech.*, 26, pp. 245-251, (1981).
- Trimm, D. L., "Catalysis Combustion - Review," *Applied Catalysis*, 7, pp. 249-282, (1983).
- Ugo, R., "The Contribution of Organometallic Chemistry and Homogeneous Catalysis to the Understanding of Surface Reactions," *Catalysis Rev. — Sci. Eng.*, 11(2), pp. 225-297, (1975).

Vogue, H. H., and Adams, C. R., "Catalytic Oxidation of Olefins," *Advan. Catalysis*, 17, p. 151, (1967).

Volkenstein, F. F., The Electronic Theory of Catalysis on Semi-Conductors, Pergamon; New York, (1963).

Warnatz, J., "The Structure of Laminar Alkane -, Alkene -, and Acetylene Flames," Eighteenth Symposium (International) on Combustion, The Combustion Institute, pp. 369-383, (1981).

Westbrook, C. K., and Dryer, F. L., "Simplified Reaction Mechanisms for the Oxidation of Hydrocarbon Fuels in Flame," *Combust. Sci. Tech.*, 27, pp. 31-43, (1981).

## PUBLICATIONS

### I. JOURNAL PAPERS

1. "Explosions with Chain Branching: Induction Period Analysis," by A. K. Sen and C. K. Law, Combustion Science and Technology, Vol. 28, pp. 75-80, (1982).
2. "Effects of Heat Loss, Preferential Diffusion, and Flame Stretch on Flame-Front Instability and Extinction of Propane/Air Mixtures," by S. Ishizuka, K. Miyasaka, and C. K. Law, Combustion and Flame, Vol. 45, pp. 293-308, (1982).
3. "On the Opening of Premixed Bunsen Flame Tips," by C. K. Law, S. Ishizuka, and P. Cho, Combustion Science and Technology, Vol. 28, pp. 89-96, (1982).
4. "On Stability of Premixed Flames in Stagnation-Point Flow," by G. I. Sivashinsky, C. K. Law, and G. Joulin, Combustion Science and Technology, Vol. 28, pp. 155-159, (1982).
5. "Catalytic Extension of Extinction Limits of Stretched Premixed Flames," by C. K. Law and G. I. Sivashinsky, Combustion Science and Technology, Vol. 29, pp. 277-286, (1982).
6. "An Experimental Study of Extinction and Stability of Stretched Premixed Flames," by S. Ishizuka and C. K. Law, Nineteenth Symposium on Combustion, The Combustion Institute, Pittsburgh, Pa., pp. 327-335, (1983).
7. "Thermal and Catalytic Inhibition of Ignition through Reactant Depletion," by C. K. Law and S. H. Chung, Combustion Science and Technology, Vol. 32, pp. 307-312, (1983).
8. "Heat and Mass Transfer in Combustion: Fundamental Concepts and Analytical Techniques," Proc. of ASME-JSME Joint Thermal Engineering Conference, (Y. Mori and W. J. Yang, Ed.), Vol. 2 pp. 535-559, (1983). \*\* Plenary Paper; \*\* also to appear in Progress in Energy and Combustion Science, 1984.

### II. MEETING PAPERS\*

1. "Catalytic Combustion in a Shear Flow," by C. K. Law, Fifth Workshop on Catalytic Combustion, San Antonio, Texas, Sept. 15-16, 1981.

---

\* Meeting papers which were subsequently published as journal papers are not included in the list.

2. "Catalytic Ignition and Extinction of Lean Mixtures in a Shear Flow," by C. K. Law and S. H. Chung, Paper No. 82-21, Tech. Meeting of the Central States Section of the Combustion Institute, Columbus, Ohio, March 22-23, 1982.
3. "Catalytic Ignition and Heat Release of Fuel-Air Mixtures," by P. Cho and C. K. Law, Spring Tech. Meeting, Western States Section/ Combustion Institute, Boulder, Colorado, April 2-3, 1984.

**END  
FILMED**

**DATE:** 7-90

**DTIC**