

AD-A148 858

LABORATORY INVESTIGATION OF MARINA ENTRANCES ON THE
MISSOURI RIVER(U) CORPS OF ENGINEERS OMAHA NE MISSOURI
RIVER DIV SEP 84 MRDL-13

1/1

UNCLASSIFIED

F/G 13/2

NL

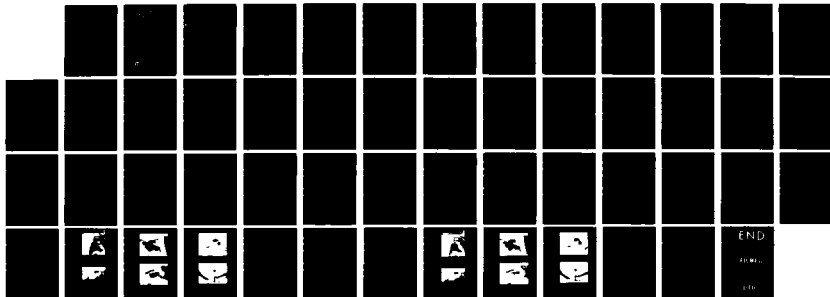

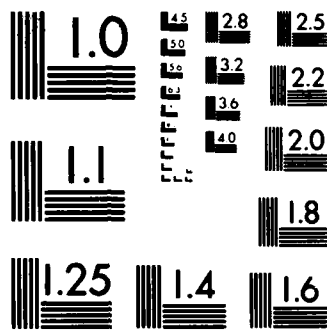

MICROCOPY RESOLUTION TEST CHART
NATIONAL BUREAU OF STANDARDS-1963-A

①

Laboratory Investigation of Marina Entrances on the Missouri River

MRD Hydraulic Laboratory Series Report No.13

AD-A148 858

Mead Hydraulic Laboratory
Mead, Nebraska

DTIC FILE COPY

September 1984

This document has been approved
for publication and sale; its
distribution is unlimited.

DTIC
ELECTE
DEC 21 1984
S
E



US Army Corps
of Engineers
Missouri River Division

84 12 11 032

**LABORATORY INVESTIGATION OF
MARINA ENTRANCES ON THE MISSOURI RIVER**

TABLE OF CONTENTS

	<u>Page No.</u>
List of Tables	TC-2
List of Plates	TC-2
List of Photographs	TC-3
List of Publications	TC-4

CHAPTER

I	Introduction	1
II	Objective	2
III	The Model	2
IV	Operating Procedures	4
V	Discussion	4
VI	Summary and Conclusion	8

Appendix A - Plates

Appendix B - Photographs

Appendix C - References

Accession For	
NTIS GRA&I	X
DTIC TAB	
Unannounced	
Justification	<i>per</i>
By	
Distribution/	
Availability Codes	
Avail and/or	
Dist	Special
A-1	

TC-1



DISK 326-C
PROJECT C6995

DEPARTMENT OF THE ARMY
CORPS OF ENGINEERS

LABORATORY INVESTIGATION OF
MARINA ENTRANCES ON THE MISSOURI RIVER

CONDUCTED AT
MEAD HYDRAULIC LABORATORY
MEAD, NEBRASKA

US ARMY ENGINEER DISTRICT, OMAHA, NEBRASKA
US ARMY ENGINEER DISTRICT, KANSAS CITY, KANSAS
MISSOURI RIVER DIVISION, OMAHA, NEBRASKA

LIST OF TABLES

<u>TABLE</u>	<u>TITLE</u>	<u>PAGE</u>
1	Prototype to Model Scale Ratios	3

LIST OF PLATES

<u>PLATE NO.</u>	<u>TITLE</u>
1.	Suspended Sediment Load vs. Discharge
2.	Model Layout
3.	Sediment Time Relationship
4.	Trial Geometries
5.	Bed Maps for Typical Perpendicular Entrance
6.	Angled Entrance Geometries Tested
7.	Bed Maps For Combination Entrance
8.	Bed Maps For Egg-Shaped Marina
9.	Double Entrance
10.	Bed Contours for Sioux City Marina
11.	Sioux City Design with No Upstream Contraction
12.	Bed Maps of Sioux City Type Marina with Projecting Spur Dike
13.	Bed Map For Sioux City Design with Sloping Dike
14.	Sloping Dike Entrance Structure
15.	Sloping Dike Entrance Structure

LIST OF PHOTOGRAPHS

PHOTO NO.

CAPTION

1. View looking upstream in model showing various entrance locations in model reach.
2. Perpendicular entrance showing sediment deposition within entrance.
3. Run 29 with combination entrance showing sediment deposition at normal discharge following flood discharge.
4. Photo showing egg shaped entrance of run 29.
5. View of Sioux City type entrance with protruding spur dike upstream following run at flood stage.
6. View of sloping spur dike following run 34.

LIST OF PUBLICATIONS

- MRD Hydraulic Laboratory Series Report No. 1, Operation and Function of the Mead Hydraulic Laboratory
- MRD Hydraulic Laboratory Series Report No. 2, Laboratory Investigation of Underwater Sills on the Convex Bank of Pomeroy Bend
- MRD Hydraulic Laboratory Series Report No. 3, Laboratory Investigation of Sioux City Boat Marina Entrance
- MRD Hydraulic Laboratory Series Report No. 4, Laboratory Investigation of Manawa and Bellevue Bends
- MRD Hydraulic Laboratory Series Report No. 5, Laboratory Investigation of Kansas River Bend and Kansas River Reach
- MRD Hydraulic Laboratory Series Report No. 6, Laboratory Investigation of Junction Losses at the Kansas and Missouri River Confluence
- MRD Hydraulic Laboratory Series Report No. 7, Laboratory Tests to Design Windrow Revetment for Bank Protection
- MRD Hydraulic Laboratory Series Report No. 8, Preliminary Laboratory Investigation of Section 32 Hard Points
- MRD Hydraulic Laboratory Series Report No. 9, Laboratory Investigation of Erosion Control using Hard Points
- MRD Hydraulic Laboratory Series Report No. 10, Laboratory Investigation of Reinforced Revetment, Type I
- MRD Hydraulic Laboratory Series Report No. 11, Laboratory Investigation of Vane Dike River Control Structures
- MRD Hydraulic Laboratory Series Report No. 13, Laboratory Investigation of Marina Entrances on the Missouri River
- MRD Hydraulic Laboratory Series Report No. 14, Laboratory Investigation of Scour Around Bridge Piers
- MRD Hydraulic Laboratory Series Report No. 15, Laboratory Investigation of Scour Downstream of Grade Control Sills on West Fork Ditch
- MRD Hydraulic Laboratory Series Report No. 16, Laboratory Investigation of Missouri River Crossing Upstream of Bushwacker Bend
- MRD Hydraulic Laboratory Series Report No. 17, Laboratory Investigation of Methods to Reduce Channel Degradation

LIST OF PUBLICATIONS CONT'D

Also available for loan:

Condensed time lapse movies summarizing laboratory investigations with narratives for:

Report No. 1
Report No. 7
Report No. 8
Report No. 9
Report No. 11

Time lapse movies of model tests without narratives for:

Report No. 7
Report No. 8
Report No. 9
Report No. 10
Report No. 11
Report No. 15
Report No. 16

MARINA STUDY

I. INTRODUCTION

1. Presented in this report are the results of model studies on Missouri River boat marina entrance configurations. This model study was conducted at Mead Hydraulic Laboratory by personnel of the Hydraulics Section of the Omaha District Corps of Engineers. The engineer in charge of the facility was R. A. Singleton. He was assisted by technicians E. E. Matson and W. J. Howard. The model study was reviewed and guidance provided by the Technical Engineering Branch of the Missouri River Division, Messrs. Alfred Harrison, Warren Mellema, and Albert Swoboda; the Kansas City District, Messrs. Walter Linder and Thomas Burke; and the Omaha District, Messrs. Howard Christian, Kenneth Murnan, and Frank Vovk. This report was prepared by Hydraulic Engineer, R. J. Buchholz.

2. Small boat marinas along alluvial rivers are constantly plagued by the deposition of sediment at marina entrances and, subsequently, within the marina themselves. Dredging of this accumulated sediment is usually required at regular intervals. The cost of this dredging and the inconvenience caused by the dredging underscore the importance of limiting sediment deposition within marinas.

3. Staffs of several facilities have conducted studies in the search for a marina entrance configuration that would reduce the amount of sediment deposited in an entrance and, subsequently, in the basin. Model studies are known to have been conducted by the following:

- a. Hydrotechnical Research Institute in Bucharest, Romania.
- b. Waterways Experiment Station (WES).
- c. University of Nebraska at Lincoln (UNL).
- d. Mead Hydraulic Laboratory.

4. The Hydrotechnical Research Institute in Bucharest studied problems relating to sediment deposition in river ports located along the Danube River, in Romania [1]. The Waterways Experiment Station (WES) model study [2] was a general investigation to determine and demonstrate some of the principles involved in shoaling in harbor entrances along navigable streams. Entrance configurations and locations for a small boat marina on the Missouri River at Sioux City, Iowa, were investigated at the Mead Hydraulic Laboratory [3]. The University of Nebraska at Lincoln (UNL) study looked at an "egg" shaped entrance for an industrial barge complex on the Missouri River near Omaha, Nebraska.*

5. All of the above studies showed that deposition occurs as a result of sediment being transferred from a high velocity region to a low velocity region. Vortices, created by the expansion of flow as it passes an opening,

[1] Numbers refer to references listed in Appendix C.

*Unpublished

cause some of the suspended sediment to be thrust into the less turbulent zone within the opening, resulting in sediment deposition. To limit deposition of sediment in the entrance, circulation is needed within the entrance to keep the sediment in suspension and to transport it back into the channel. The deposition of sediment in marina entrances is due principally to:

- a. The suspended sediment load in the stream.
- b. Alignment of the marina entrance with the channel.
- c. Variations in river stage (discharge).
- d. Marina entrance geometry.

The large suspended sediment load of the Missouri River is believed to be the major factor involved in marina entrance siltation on this river. Because of the many interrelated factors, a generalized model study was undertaken to determine which entrance configuration would minimize sediment deposition. It should be noted that only the deposition of sediment in the marina entrance was considered since minimizing sediment deposition in the entrance would also minimize sediment deposition in the marina.

II. OBJECTIVE

6. The goals of this model study were to investigate various marina entrance designs which have been used on the Missouri River, determine the good and bad qualities of each type of entrance configuration, and identify critical design features. Originally this model study also was to investigate entrance geometries for a marina at Jefferson City, Missouri. However, plans for a marina at Jefferson City were never finalized; and consequently, this report presents only general results on the marina entrances on the Missouri River.

7. Recognizing that no system of entrance structures or alignment will totally prevent the deposition of sediment, the objective of this investigation was to determine how to minimize the deposition of sediment in a marina entrance. This investigation evaluated the Sioux City type marina entrance which incorporated recommendations from the Bucharest Report. Also studied were the UNL egg-shaped basin and other successful marina entrances on the Missouri River.

III. THE MODEL

8. The model was constructed in such a way as to provide for multiple openings along the model channel to enable testing of several entrance geometries at the same time, thereby speeding up the test schedule. Plate 2 and photo 1 show the model reach with four of the openings that were tested simultaneously. The entrance for each marina opening was constructed so that at normal stage (model depth of 0.42 feet) the entrance width would be 1 foot

in the model. This served as a control since the opening width would vary with the stage due to the sloping sides of most of the entrance structures tested. Consequently, the opening width at high stage was greater than that at normal stage.

9. Due to the importance of the suspended sediment load parameter, a high concentration of suspended sediment was maintained in the model flows. The bed material consisted of ground walnut shells with a uniform gradation, a specific gravity of 1.30, and a median size of 0.30 mm. Table 1 presents some of the prototype to model scale ratios for two locations on the Missouri River.

TABLE 1
PROTOTYPE TO MODEL SCALE RATIOS

	Hermann, MO	Sioux City, IA
Horizontal scale, L_r	60:1	60:1
Vertical scale, H_r	30:1	30:1
Unit sediment discharge Ratio, $(q_s)_r$	425:1	157:1
Unit water discharge Ratio, $(q)_r$	187:1	168:1
Sediment Time Ratio, T_r	4.4:1	11.5:1

10. The quantity of sediment in the lower Missouri River is much greater than in the upper Missouri River. For this reason, two locations were selected to compute the sediment time ratios, one in the upper and one in the lower Missouri River. Suspended sediment data obtained near Hermann, Missouri, (about 100 miles upstream of the mouth of the Missouri River) and at Sioux City, Iowa, (at the upstream end of the navigable portion of the Missouri River) were used in calculating the unit sediment discharges and the sediment time ratios. The suspended sediment information was obtained from "Suspended Sediment in the Missouri River," for water years 1955-1974 [5], [6], [7]. Reference 5 also summarizes the suspended sediment concentration in the Missouri River from 1955-1959. The suspended sediment load vs discharge curves for Sioux City, Iowa, and Hermann, Missouri, are shown on plate 1. While sediment data for the prototype does not include the bed load, the model sediment data includes both bed load and the suspended load. When calculating the sediment time ratio, it was assumed that the bed load was negligible compared to the suspended sediment load. If the bed load had been taken into account in the prototype, the time ratios would have decreased slightly.

11. The Mead model basin construction techniques, similitude criteria, and measurement procedures are detailed in the MRD Hydraulic Laboratory Series Report No. 1, "Operation and Function of the Mead Hydraulic Laboratory," [4]. Also described in this report are the test and model verification procedures used in the model studies conducted at the Mead Laboratory Facilities.

IV. OPERATING PROCEDURES

12. Fluctuating water surface elevations may cause problems at marina entrances. Deposits formed during these high stages may accumulate above the normal water surface elevation and then impede circulation in the marina entrance at normal stage. For this reason, all model entrance geometries were tested with combinations of high and normal stages. Normal stage represented the 1973 Construction Reference Plane (CRP) elevation at Sioux City, Iowa, and Hermann, Missouri. These elevations correspond to discharges of 30,000 and 54,000 cfs, respectively. The usual test sequence was to start with a normal stage, run for about 24 hours, change to a high stage, run for about 24 hours, and then run a normal stage again for another 24 hours. Runs were usually 24 hours in duration, allowing sufficient time to enable the bed configuration and sediment transport to reach equilibrium. In this study, twenty-four hours represented about 4.5 days in the lower Missouri River and about 11.5 days in the upper Missouri River (See plate 3). After each test and prior to the next test, the bed elevation of the entrance was leveled to that of the main channel bed to ensure similar starting conditions. At the start of a run, the model was slowly filled with water to eliminate any possible surging effect which could alter the bed. For runs 1-21, Polaroid snapshots and some hand sketched bed contour maps were drawn but no detailed measurements or analyses were made. For runs 22-39, cross sections of the marina entrances and several control sections in the model were taken using a sonic sounder and X-Y plotter. The data from the channel cross sections were used to develop contour maps of the different marina entrances. Black and white photographs were taken of runs 22-39. Time lapse movies were taken of the Sioux City type entrance during runs 26 and 27.

V. DISCUSSION

13. The following tests were performed:

- a. Preliminary tests (runs 1-21).
- b. Other entrance tests (runs 29-33), during which various entrance geometries were studied simultaneously.
- c. Sioux City type entrance tests (runs 22-28).
- d. Sloping dike tests (runs 34-39).

Preliminary Tests.

14. The first test series (runs 1 to 21) consisted of runs in which the geometries of the marina entrances were varied to determine the configuration which would best minimize sediment deposition in the openings. These preliminary runs were basically trial and error attempts to obtain a better understanding of the sediment deposition/scour processes which occur within the various entrance geometries at fluctuating stages. Sketches of some of the entrance geometries tested and a brief description of the observed results are shown on plate 4.

Other Entrance Tests.

15. Perpendicular Entrance. Because of its simplicity in design and construction, a perpendicular type entrance, see plate 5, is the most common type of entrance used on the Missouri River. Two types of perpendicular entrances were tested, one with sharp right angle corners to represent an entrance constructed with sheet piling, and the other with smooth rounded corners to represent a dredged entrance condition. Both types of perpendicular entrances filled with sediment during the tests because of a lack of circulation within the entrances, see photo 2. Plate 5 presents the bed contour maps resulting from a combination of flood and normal flows.

16. Angled Entrance. The angled entrance, see plate 6, is also a fairly common marina entrance used on the Missouri River. Several types of angled entrance geometries were tested, which included the placement of baffles at various locations within the entrance area. In all of these tests, the entrance filled with sediment due to the absence of circulation within the entrance. Baffles were placed around the entrance in an attempt to create circulation within the marina entrance. Upstream baffles tended to deflect sediment into the entrance where it deposited and blocked the entrance. Downstream baffles caused sediment deposition upstream of the baffles, eventually blocking the entrance. Combinations of upstream and downstream baffles did not induce circulation within the entrance. An underwater sill upstream and baffle downstream also induced sediment deposition in the marina entrance.

17. Combination Entrance. Several tests were made with an entrance which combined the angled and the perpendicular entrances. The upstream portion of the entrance was perpendicular to the main channel while the downstream portion was angled, see plate 7. During the initial normal stage period, little sediment was deposited in the entrance as shown on plate 7, figure 1. A period of high stage was then simulated which resulted in a large area of deposition along the downstream angled wall with the main entrance remaining open. (See plate 7, figure 2.) Following high stage simulation, a period of normal stages were simulated. The bar located along the downstream wall grew larger and a finger extended across the entrance that would have eventually blocked the entire entrance (see plate 7, figure 3, and photo 3).

18. Egg-Shaped. The egg-shaped entrance consisted of a rounded upstream opening and dished out downstream opening (see plate 8). This entrance was tested during run 29. At normal stage, the entrance remained open with some bar accretion along the dished out downstream zone (see plate 8, figure 1). The downstream bar expanded and began encroaching on the entrance during the high stage period (plate 8, figure 2, and photo 4). The entrance, however, remained open until the normal stage period, at which time the bar extended itself across the downstream half of the entrance and reduced the depth across the remainder of the entrance as seen on plate 8, figure 3. The egg-shaped entrance had a much greater volume than that of the other entrance configurations studied and, therefore, the entrance required a longer period to fill with sediment. Caution is therefore needed when analyzing the first normal stage period since the basin would probably accrete to the water surface, but would require a longer time period because of the greater volume.

19. Double Entrance. A double entrance type of marina has been used at a few locations along the Lower Missouri River, with apparent good results. All model tests on the double entrance configuration (see plate 9) produced negative results in that the entire basin filled with sediment. The actual locations and entrance geometry of existing double entrance marinas, on the Missouri River, would have to be studied in detail to better evaluate their performance.

Sioux City Type Entrance Tests.

20. The entrance of the existing marina at Sioux City, Iowa, has performed extremely well since it was constructed in August 1969. A series of model tests utilized the entrance orientation of the prototype and several variations of the prototype geometry to determine the critical components of the design. A general layout sketch of the prototype configuration with contours from a 1971 survey of the entrance is shown on plate 10. Several different configurations of the Sioux City entrance were tested to observe how changes in the geometry of the entrance affected sediment deposition within the entrance.

21. The Sioux City marina entrance consists of a crossing structure on the upstream side of the entrance and an "L" shaped structure on the downstream side of the entrance. The crossing structure was found to contract the flow and increase the local velocity. This produced a drawdown (local depression) in the water surface at the downstream end of the crossing structure, which induced a reverse flow or circulation downstream from the crossing structure. The "L" shaped structure downstream of the entrance was found to reinforce the circulation. As a result of the circulation in this downstream area, most of the sediment entering this area was directed toward the upstream crossing control structure where it was re-entrained in the channel flow. Plate 10 illustrates the circulation pattern in the "L" downstream of the crossing structure. In both the model and the prototype, some of the sediment formed a deposit riverward of the "L" structure which ultimately approached the normal water surface. This deposit poses no major problems if the river stages are relatively constant, but problems could develop if there are large fluctuations in stage. Prolonged high stages could leave a sediment deposit which is exposed when the flow returns to normal stage, thus destroying the circulation within the entrance and causing the remainder of the open entrance area to fill with sediment.

22. The Sioux City site is unique because it is situated at a river crossing. At other locations it may not be possible to contract the flow because the constricting structure might encroach on the navigation channel. As a result of this, variations of the Sioux City type entrance were studied.

23. Sioux City Entrance with No Constriction. One variation of the Sioux City design was tested using an approach that did not contract the flow. This design produced a large deposit along the downstream "L" structure, which eventually affected the circulation pattern and caused sediment deposition in the entrance channel, restricting access to the marina (see plate 11). The entrance accreted primarily because there was no flow contraction upstream of the entrance to induce circulation in the entrance, as previously described.

24. Sioux City Entrance with Spur Dike. A small spur dike projecting into the flow from the upstream face of the entrance was then tested to see if the results would be similar to those of the Sioux City type entrance. Because of navigation requirements, the upstream and downstream structural revetments were set back from the original channel line to permit the spur dike to project into the flow. This spur dike caused a more abrupt contraction of the flow, which resulted in a strong circulation pattern. This type of entrance performed well, with good circulation, except that the bars in the "L" structure accreted to the water surface during high stages (see photo 5). Upon returning to normal stage, the bar in the "L" structure was above the water surface and cut off circulation in the entrance. When this happened, the entrance behaved similar to the perpendicular type of entrance and filled with sediment. The bed contour maps for a combination of high and normal stages are shown on plate 12.

Sloping Dike Tests.

25. Sioux City Entrance with Sloping Spur Dike. It was reasoned that with a sloping sill the circulation pattern would still exist at normal stage; but at high stages, water going over the sloping sill would scour downstream deposits. This latter action would be accomplished by the water overtopping the spur dike and developing a rolling action in the area immediately downstream of the spur dike, thus preventing deposition at high stages. As a second benefit, sediment deposits formed during the normal flow period would be removed.

26. The projecting spur dike was then replaced with a sloping spur dike. The sloping spur dike had a crown which sloped down towards the channel and was submerged at flood stages (see plate 13). However, during these runs, sediment accumulated inside the "L" structure in a way similar to runs with the spur dike. As a result, the circulation pattern was destroyed and the "L" structure filled with sediment.

27. Sloping Spur Dike with Angled Downstream Opening. Since the sediment that accumulated within the "L" structure effectively negated the purpose of the "L", the "L" structure was removed and replaced with an angled downstream opening. Sediment deposition did occur downstream from the spur dike during high stages, but the deposition was not as extensive as that which occurred with the "L" structure (plate 14, figure 1). During the period of normal stages following the high stages, more sediment deposited around the entrance; however, the entrance remained open (plate 14, figure 2). A run at an intermediate stage did increase the deposit (photo 6) but the entrance remained open (plate 15, figure 1). A high stage was run to see if it would scour out the deposit downstream of the sloping spur dike. The scouring action did not take place and the deposit increased to the extent that it nearly blocked the entrance (plate 15, figure 2). The sloping dike configuration never caused a deposit that totally blocked the entrance, as was the case with other designs; however, deposits still encroached on the entrance.

VI. SUMMARY AND CONCLUSION

28. Only a qualitative comparison of the results and relative effectiveness of the various entrance geometries was made. The study was general in scope and did not address any specific river alignment.

29. The best entrance for a steady flow condition was the Sioux City type (see plate 10). The best entrance configuration with fluctuating stages was the modified Sioux City type entrance with a sloping spur dike (see plate 13). An additional modification was one where the "L" structure was replaced with an angled revetment downstream (see plate 14). Each had deposition in the entrance, but the sloping dike gave the best results. It must be remembered that no system of entrance structures will prevent the sediment deposition process entirely.

30. High suspended sediment concentrations play a major role in sediment deposition within marina entrances on the Missouri River. If a long duration flood with high sediment concentrations occurred, the Sioux City type marina could become inoperable after a return to normal stage. A short duration flood would probably not affect this type of entrance, nor would floods with low suspended sediment concentrations.

31. The suspended sediment concentrations in the downstream reaches of the Missouri River are much greater than those in the upper reaches near Sioux City, as a result, marina entrances near the mouth of the Missouri would tend to fill with sediment faster than those farther upstream. Because of the high suspended sediment concentrations, circulation in the entrance must be maintained to minimize the suspended sediment deposition. The Sioux City type of marina entrance is the best under relatively steady stages, as attested to by the many successful years of operation on the Missouri River.

32. The sloping spur dike marina entrance (see plate 14) seemed to perform adequately, but still had sediment deposition problems. A sloping spur dike type of marina entrance has never been built on the Missouri River, so no verification of model results are available. Also, the downstream roller produced by the sloping dike structure during high stages may create a safety hazard.

33. The other types of entrance configurations tested do not appear to have any merit since they all tended to fill with sediment in relatively short periods of time, even at normal stages. In an alluvial river with high concentrations of suspended sediment, an entrance configuration which promotes a strong circulation pattern at the entrance is the most desirable.

34. It has been reported that there are locations in the lower Missouri River, for flows up to bank full, where the sediment distribution approaches zero. These locations are reportedly about one-fourth mile downstream of bends along the concave bankline. The sediment distribution is said to approach zero at these points because the secondary or helical flows cease or separate from the bank line. Therefore, constructing a marina at one of these locations would alleviate dredging and maintenance problems in a marina. Further investigation into this concept may be warranted.

APPENDIX A

PLATES

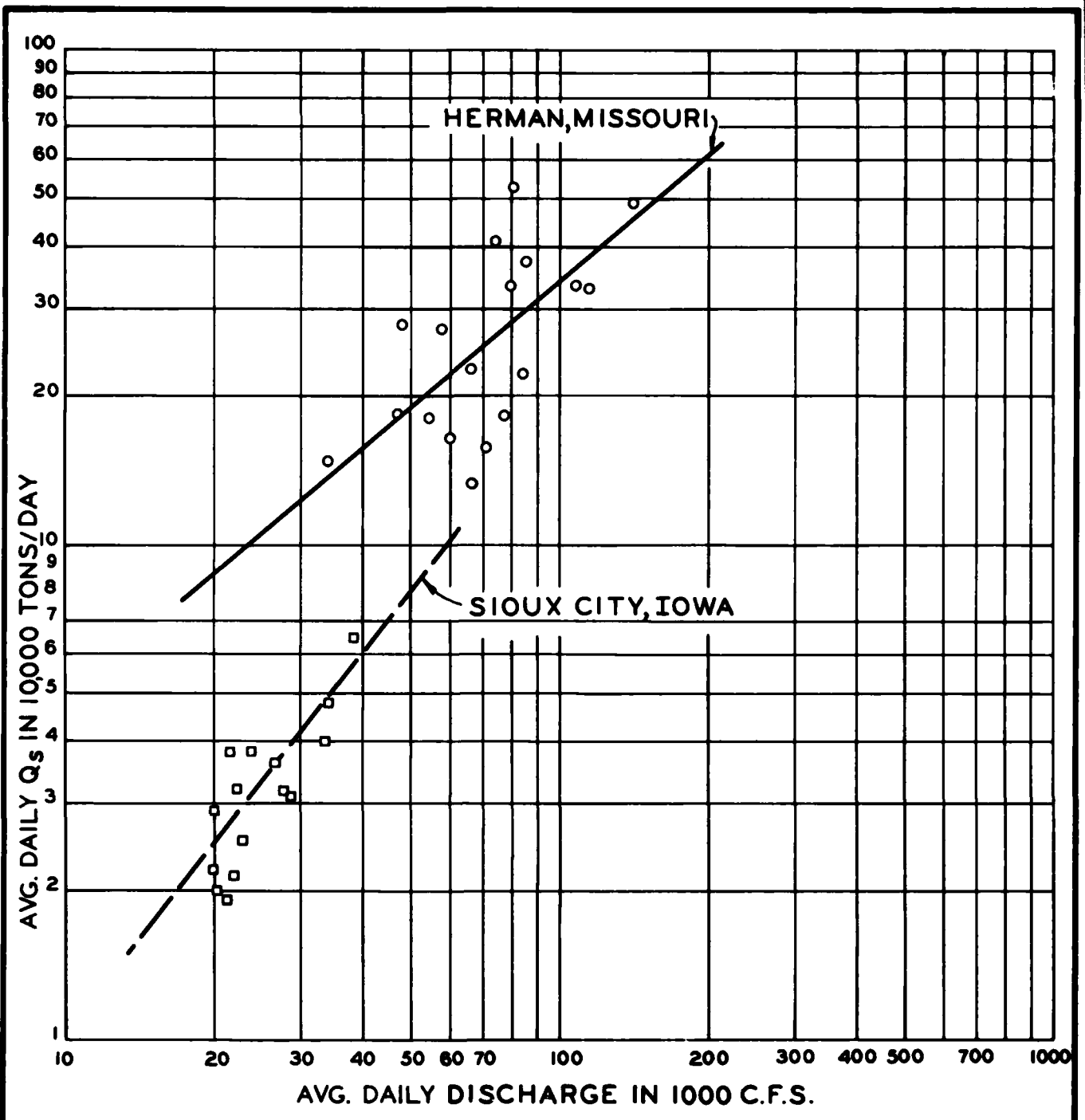

MEAD HYDRAULIC LABORATORY
MARINA STUDY
 SUSPENDED SEDIMENT LOAD
 VS DISCHARGE

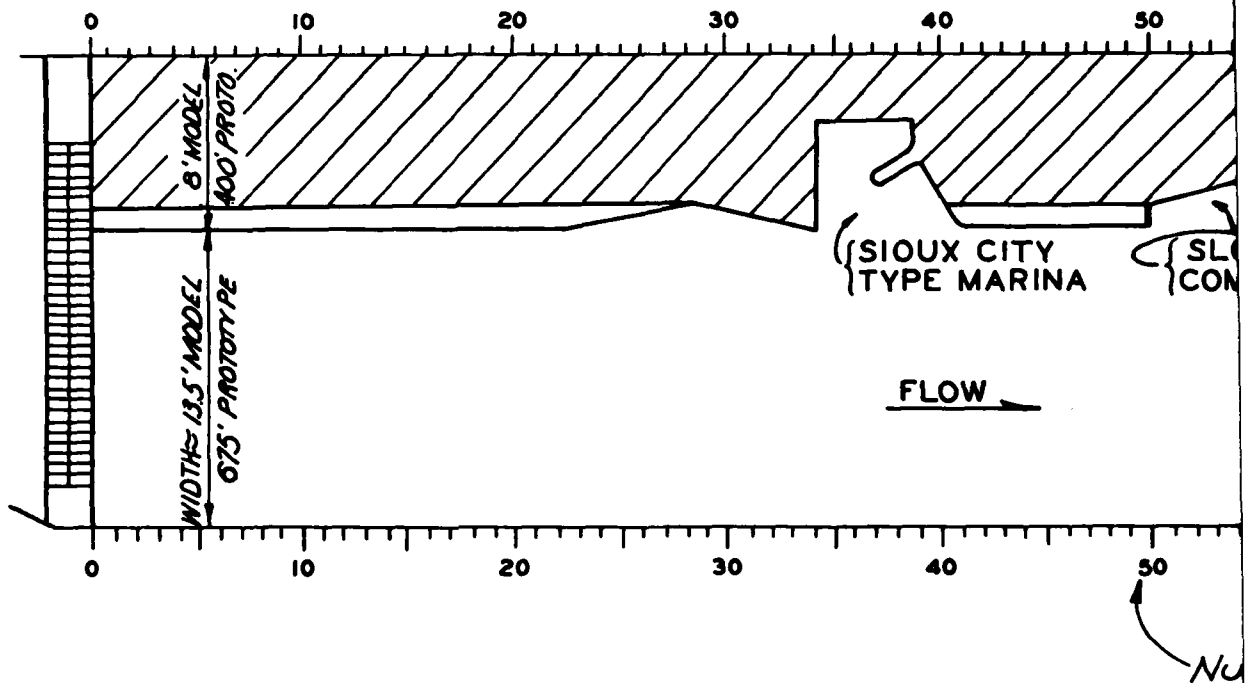
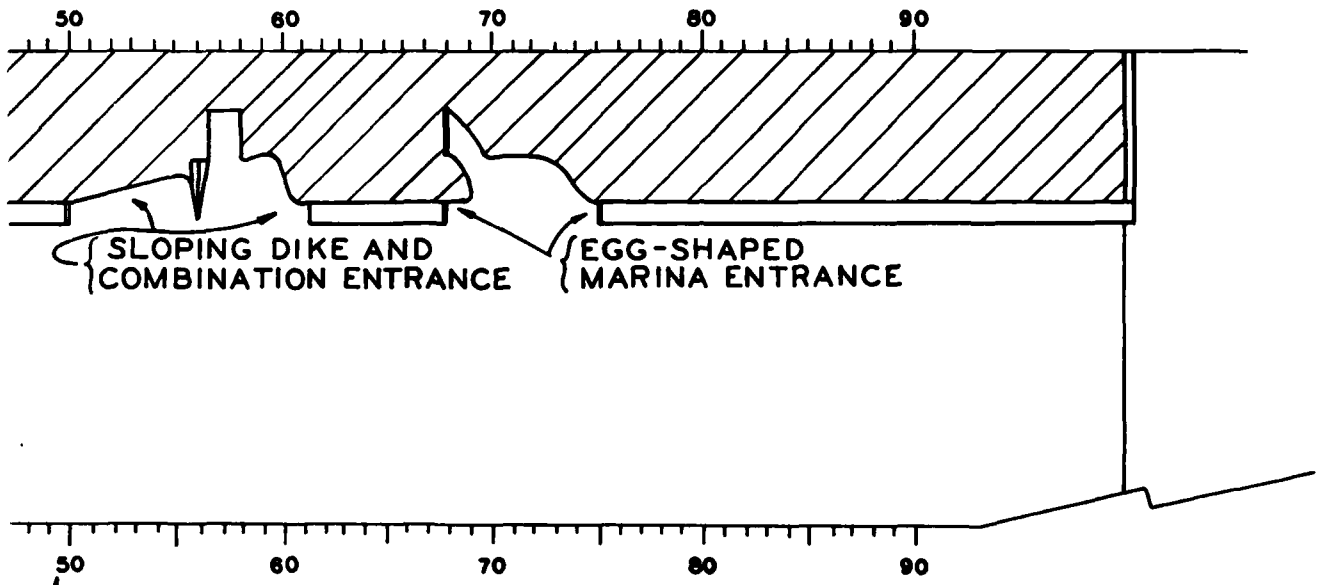

PLATE 2



Numbers indicate stationing in feet

MEAD HYDRAULIC LABORATORY
MARINA STUDY
MODEL LAYOUT

2 of 2

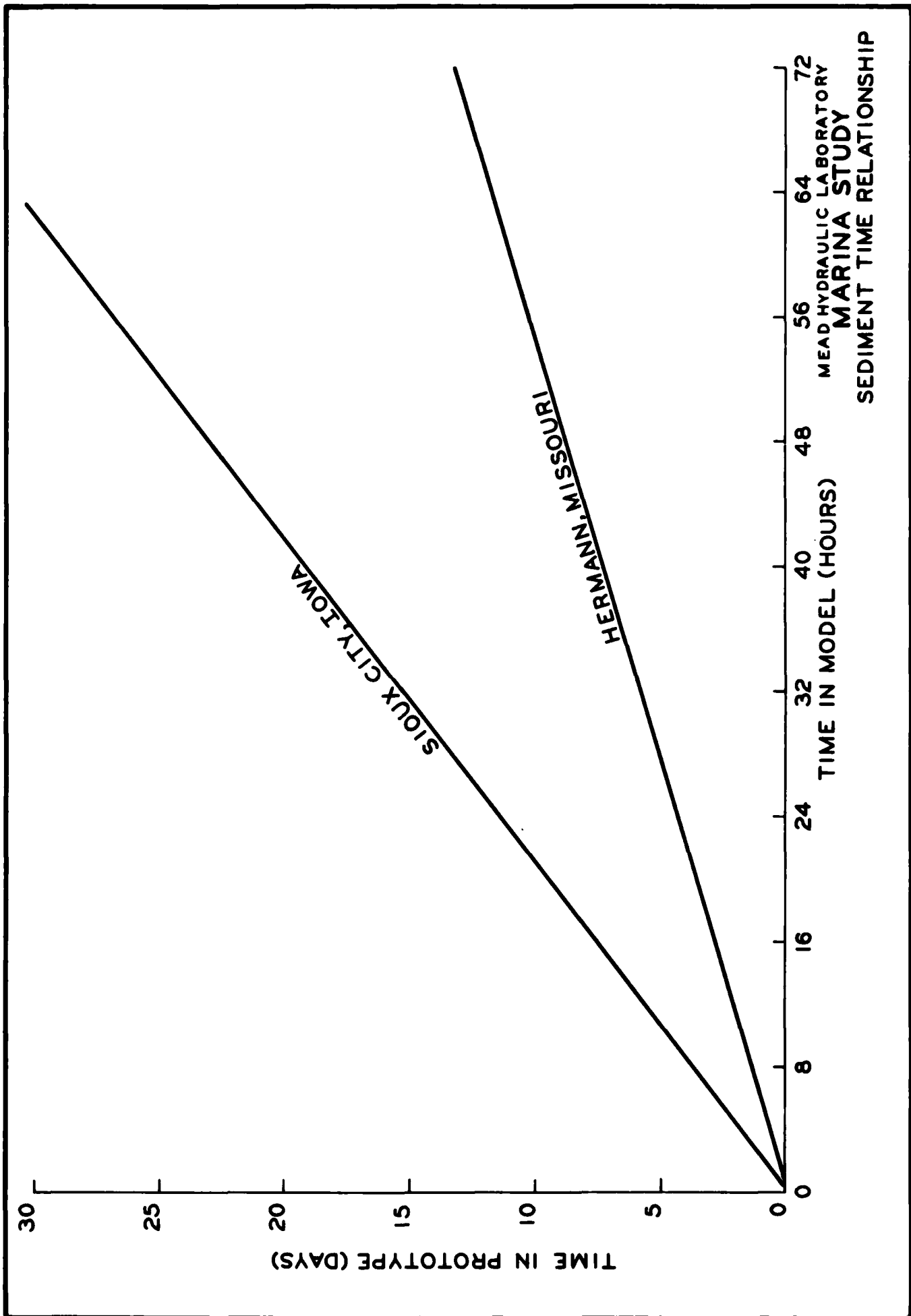

MEAD HYDRAULIC LABORATORY
 MARINA STUDY
 SEDIMENT TIME RELATIONSHIP

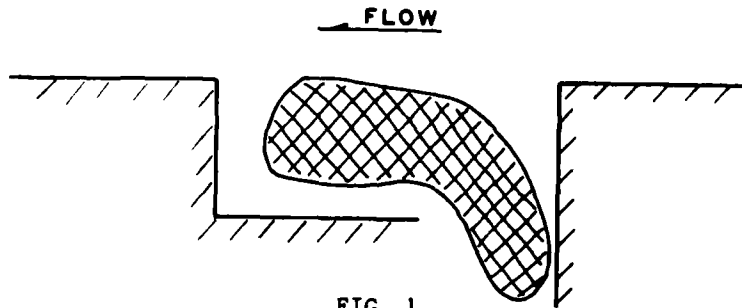

FIG 1
*RUN 11A, DIMENSIONS 1.0-1.5-1.0; LARGE BAR DEVELOPED IN ENTRANCE

*NOTE: See legend for explanation of "L" Structure

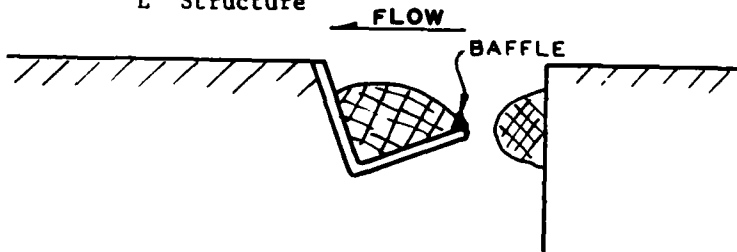

FIG. 2
RUN 13D, DIMENSIONS 1.2-1.2-1.0, FLOOD STAGE, LARGE DEPOSIT INSIDE "L" STRUCTURE CAUSED BY BAFFLE, DEPOSIT EXTENDING ACROSS ENTRANCE FROM UPSTREAM WALL

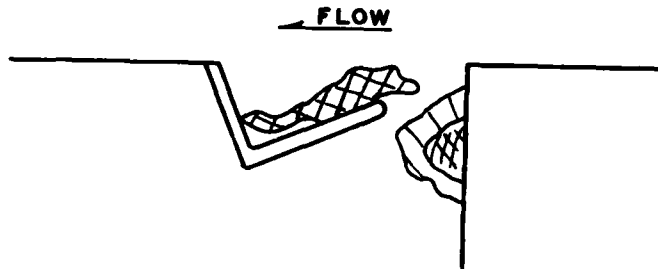

FIG. 3
RUN 14E, DIMENSIONS 1.0-1.5-1.0; FLOOD STAGE, BAR FORMED INSIDE OF "L" STRUCTURE: LARGE DEPOSIT FORMED ACROSS ENTRANCE FROM UPSTREAM ENTRANCE WALL

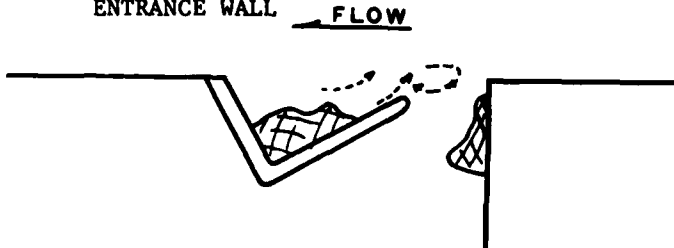

FIG 4
RUN 14F; DIMENSIONS 1.0-1.5-1.0; FLOOD STAGE, BAR FORMED ALONG UPSTREAM WALL AND EXTENDED INTO ENTRANCE: BAR IN CENTER OF "L" STRUCTURE

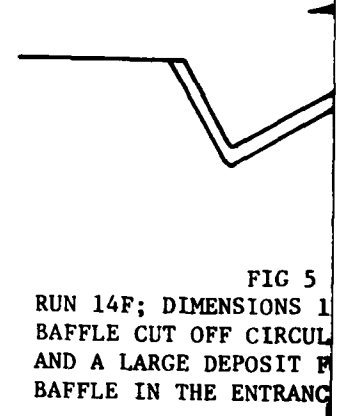

FIG 5
RUN 14F; DIMENSIONS 1.0-1.5-1.0; BAFFLE CUT OFF CIRCULATED FLOW AND A LARGE DEPOSIT FORMED IN THE ENTRANCE



FIG 6
RUN 14D; DIMENSIONS 1.0-1.5-1.0; FLATTENED "L" ANGLE, FLOW DEFLECTS SEDIMENT TO TURN FLOW BUT LARGE DEPOSIT FORMS BEHIND BAFFLE

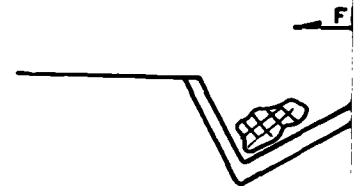

FIG 7
RUN 14F, DIMENSIONS 1.0-1.5-1.0; UNDERWATER SILL OFF LEG DEFLECTS SEDIMENT INTO ENTRANCE AND DEPOSITED AND BLOCKED THE ENTRANCE

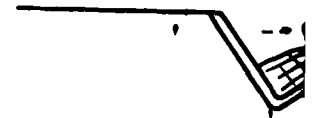

FIG 8
RUN 15E, DIMENSIONS 2.0-1.5-1.0; LEG OF "L" STRUCTURE THICK WHICH FORCED SEDIMENT INTO ENTRANCE AND DEPOSITED AND BLOCKED THE ENTRANCE

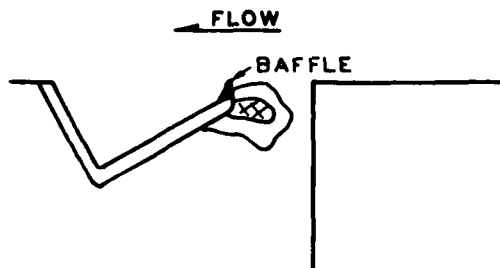

FIG 5
DIMENSIONS 1.0-1.5-1.0, FLOOD STAGE,
SILL OFF CIRCULATION AROUND "L" STRUCTURE
LARGE DEPOSIT FORMED UPSTREAM OF THE
ENTRANCE.

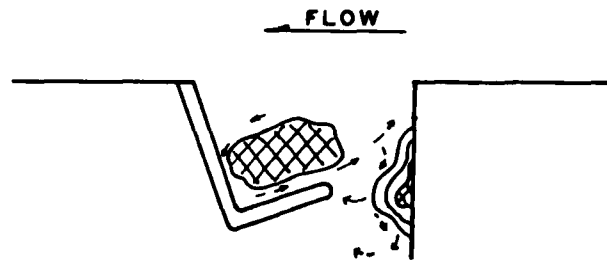

FIG 9
RUN 16C, DIMENSIONS 1.5-1.0-1.0, FLOOD STAGE,
LEG OF "L" STRUCTURE TOO SHORT, CURRENT DEFLECTED
INTO ENTRANCE WHERE SEDIMENT DEPOSITED AND
BLOCKED ENTRANCE

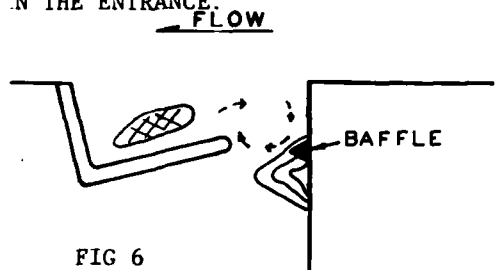

FIG 6
DIMENSIONS 1.0-1.5-1.0, FLOOD STAGE,
'L' ANGLE, FLOW STRIKES UPSTREAM WALL
SEDIMENT TOWARD MARINA BASIN: BAFFLE
BUT LARGE DEPOSIT THAT BLOCKS THE
ARMS BEHIND BAFFLE

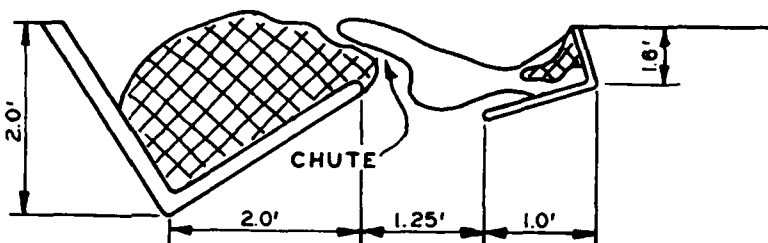

FIG 10
RUN 18, FLOOD STAGE, SEDIMENT DEPOSITED ALL THE WAY
ACROSS ENTRANCE EXCEPT FOR A SMALL CHUTE THROUGH
THE CENTER

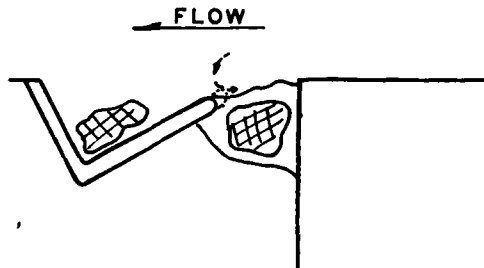

FIG 7
DIMENSIONS 1.0-1.5-1.0; FLOOD STAGE,
SILL OFF LEG OF "L" STRUCTURE; DE-
POSITED INTO ENTRANCE WHERE IT
BLOCKED THE ENTRANCE

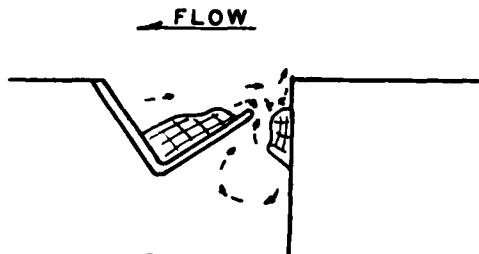
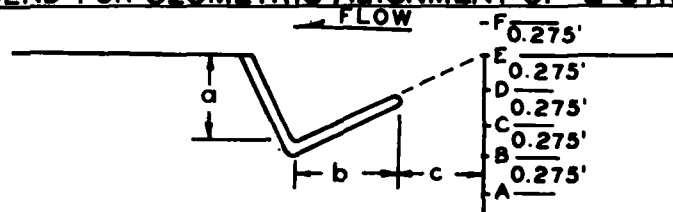

FIG 8
DIMENSIONS 2.0-2.0-1.0, FLOOD STAGE,
'L' STRUCTURE TOO CLOSE TO UPSTREAM WALL
SEDIMENT DEPOSITED INTO BASIN WHERE IT DE-
POSITED BLOCKED THE ENTRANCE

LEGEND FOR GEOMETRIC ALIGNMENT OF "L" STRUCTURE



EXAMPLE: RUN 14 E DIMENSIONS a-b-c
ALIGNMENT(A-F)

- a - DOWNSTREAM DIMENSION PERPENDICULAR TO FLOW
- b - HORIZONTAL DIMENSION PARALLEL TO FLOW
- c - OPENING DIMENSION PARALLEL TO FLOW

MEAD HYDRAULIC LABORATORY
MARINA STUDY
TRIAL GEOMETRIES

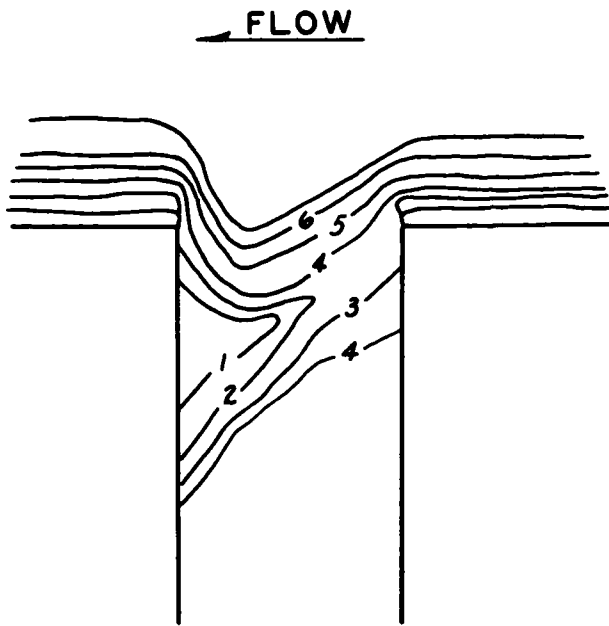

FIG 1
RUN 29 AT NORMAL STAGE, RUN TIME=28.4 HRS

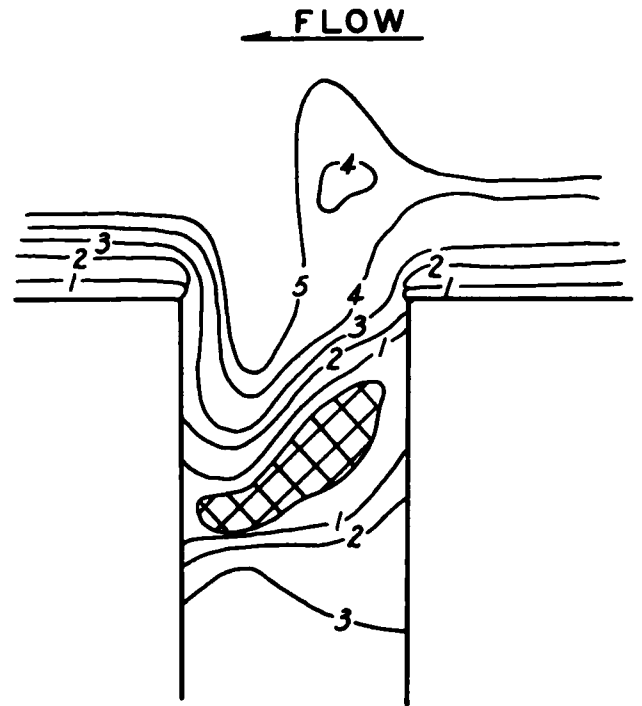

FIG 2
RUN 29 AT FLOOD STAGE, RUN TIME = 45.2 HRS

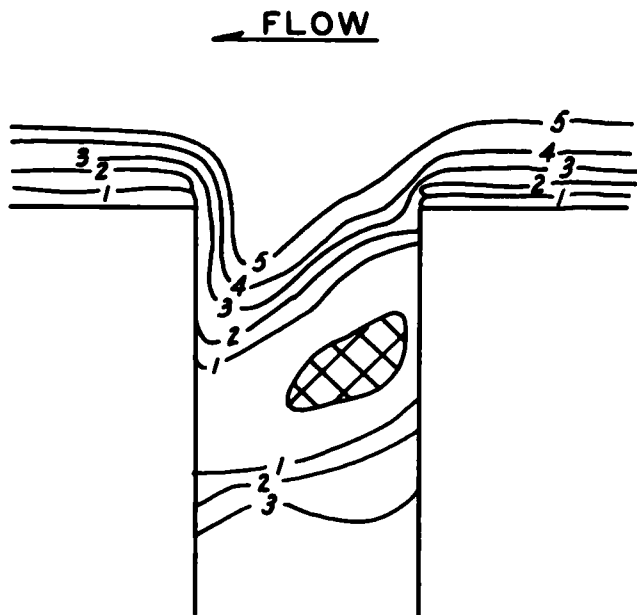
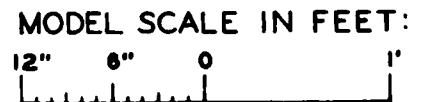

FIG 3
RUN 29 AT NORMAL STAGE, RUN TIME = 95.2 HRS

LEGEND

CONTOUR NO.	DEPTH BELOW NWS, FT.
1	= 0.1
2	= 0.2
3	= 0.3
4	= 0.4
5	= 0.5
6	= 0.6
⊗	= BAR AT OR ABOVE WATER SURFACE



MEAD HYDRAULIC LABORATORY
MARINA STUDY
BED MAPS FOR TYPICAL
PERPENDICULAR ENTRANCE

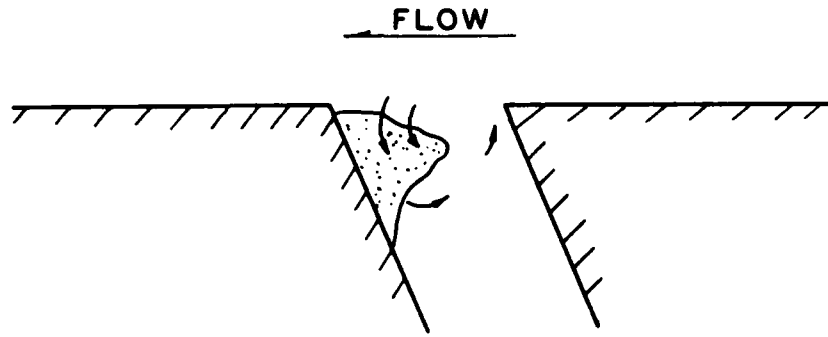

FIG. 1
SERIES 19, ANGLED ENTRANCE WITHOUT BAFFLE, FLOOD STAGE,
APPROXIMATELY 1/2 OF ENTRANCE FILLED WITH SEDIMENT

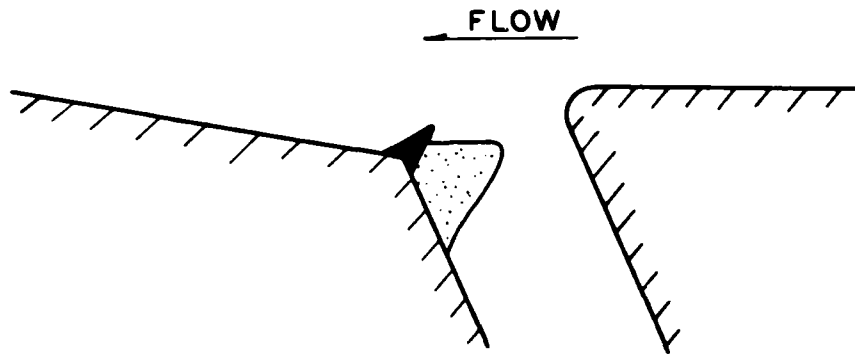

FIG. 2
SERIES 19, ANGLED ENTRANCE WITH BAFFLE SILL D/S, FLOOD
STAGE, SEDIMENT DEPOSITED BEHIND BAFFLE ACROSS 1/2
ENTRANCE

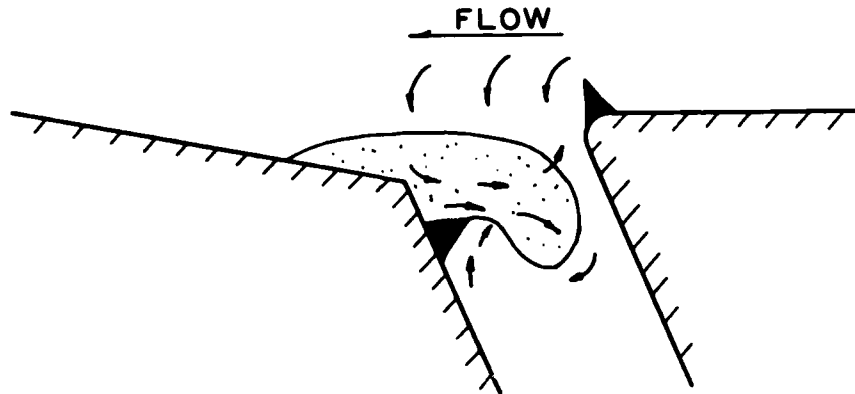

FIG. 3
SERIES 19, ANGLED ENTRANCE WITH BAFFLE U/S AND D/S, FLOOD
STAGE, U/S BAFFLE DEFLECTED SEDIMENT INTO ENTRANCE
BLOCKING ENTIRE CHANNEL, D/S BAFFLE USELESS

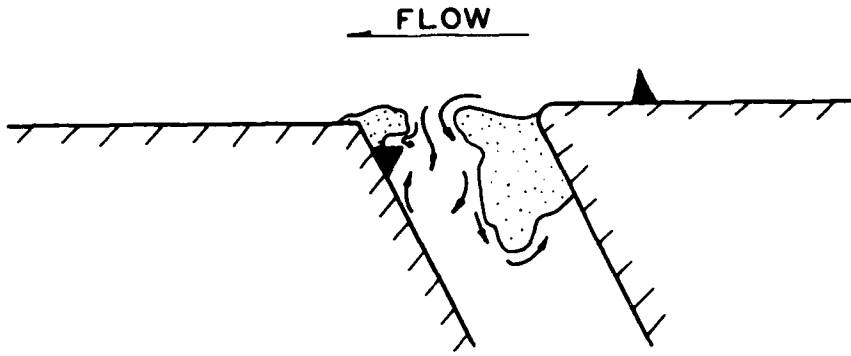

FIG. 4
 SERIES 19, ANGLED ENTRANCE WITH BAFFLE U/S AND D/S,
 FLOOD STAGE, SEDIMENT ACCUMULATED IN ENTRANCE, LITTLE
 CIRCULATION

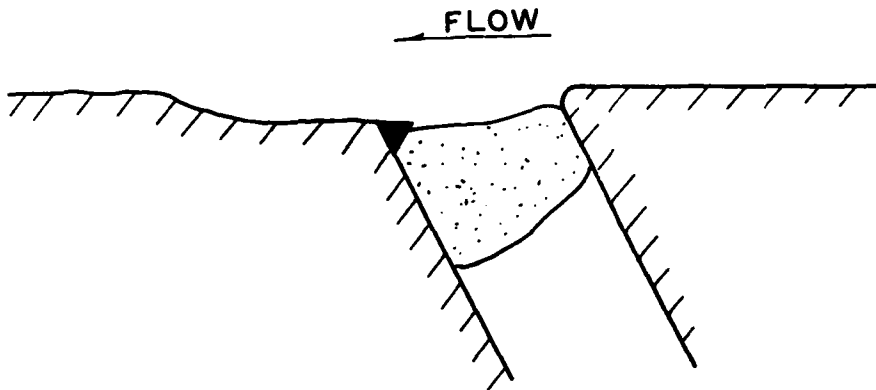
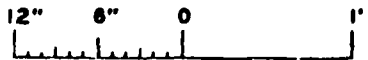

FIG. 5
 SERIES 19, ANGLED ENTRANCE WITH BAFFLE DOWNSTREAM, FLOOD
 STAGE. FAIRLY UNIFORM DEPOSIT APPROXIMATELY 0.5 FOOT
 DEEP ACROSS ENTRANCE, PERFORMED BETTER THAN OTHER TRIALS

MODEL SCALE IN FEET:



LEGEND

▲ = BAFFLE

◻ = DEPOSIT

MEAD HYDRAULIC LABORATORY
 MARINA STUDY
 ANGLED ENTRANCE
 GEOMETRIES TESTED

2 of 2

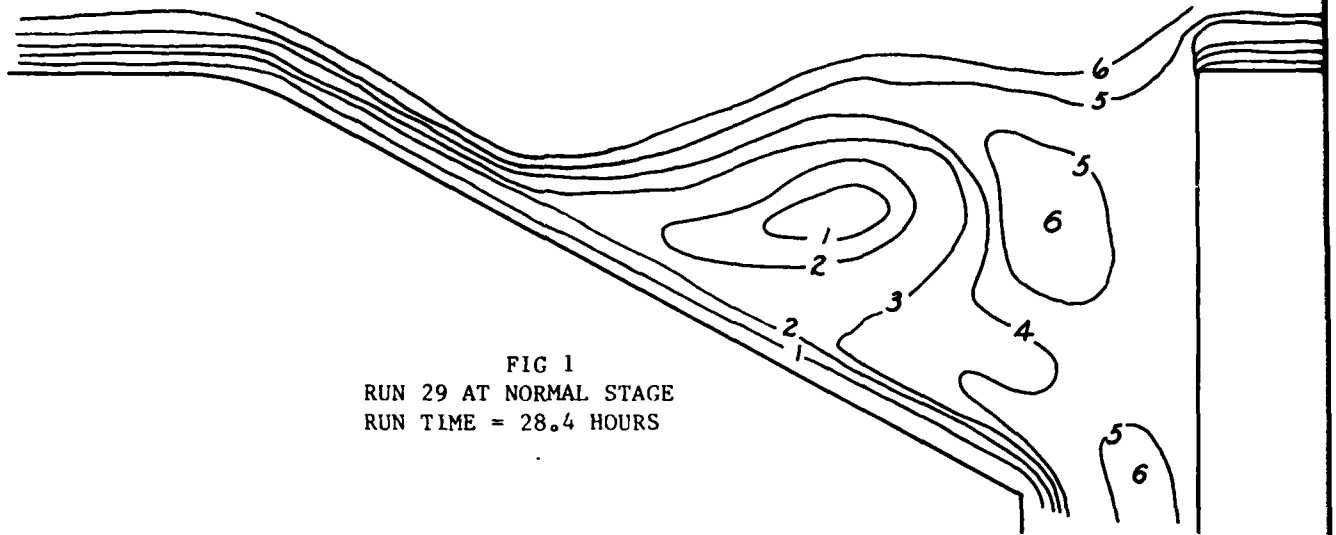

FIG 1
RUN 29 AT NORMAL STAGE
RUN TIME = 28.4 HOURS

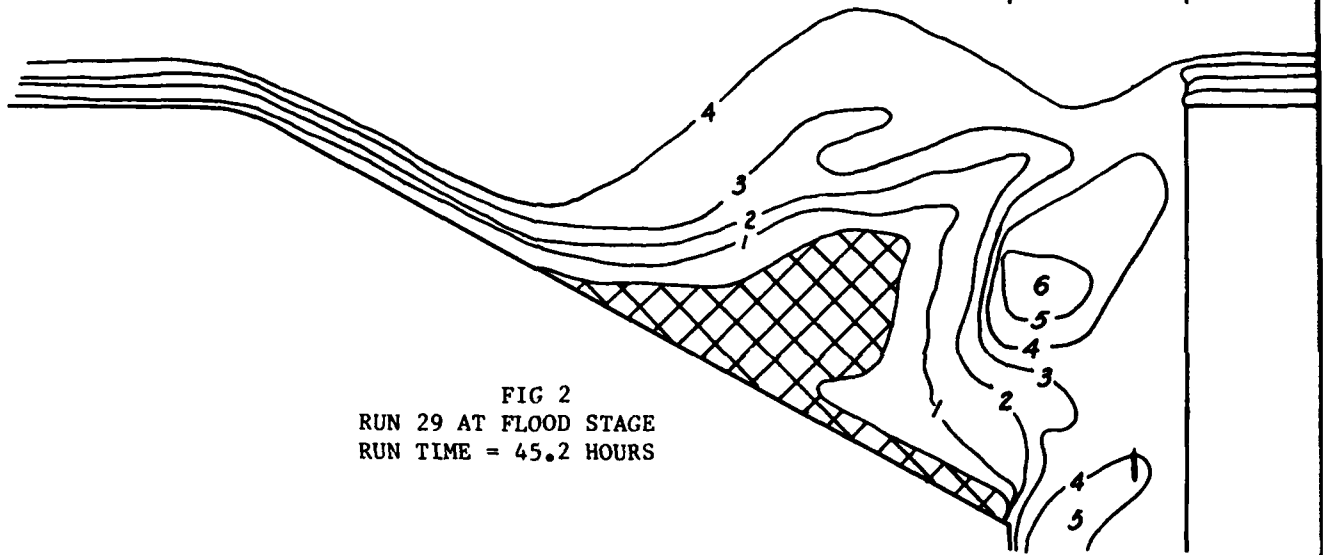

FIG 2
RUN 29 AT FLOOD STAGE
RUN TIME = 45.2 HOURS

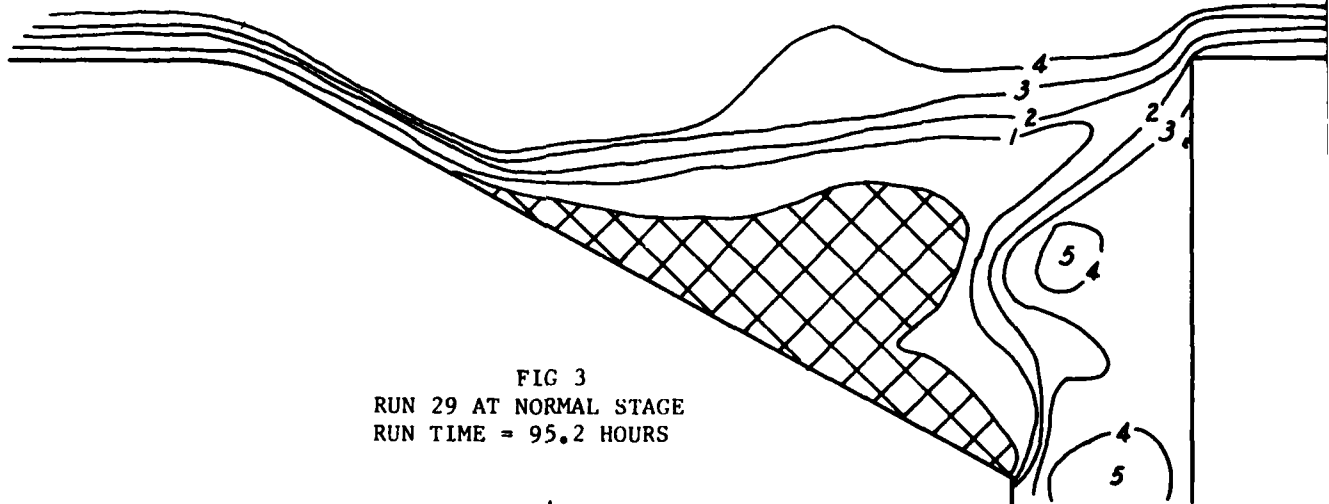
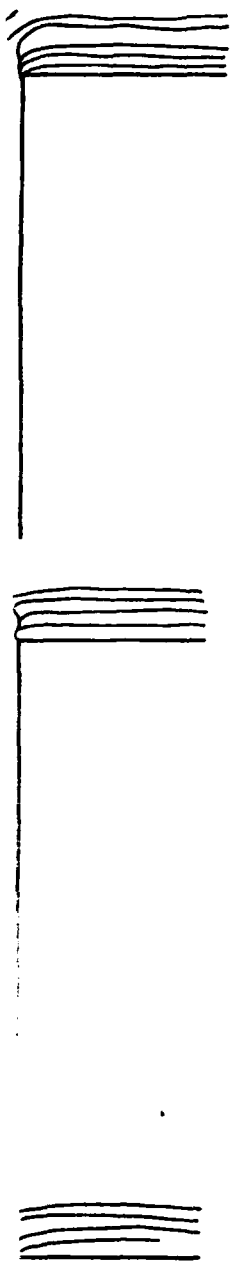

FIG 3
RUN 29 AT NORMAL STAGE
RUN TIME = 95.2 HOURS



LEGEND

<u>CONTOUR</u> <u>NO.</u>	<u>DEPTH BELOW</u> <u>NWS, FT.</u>
1	= 0.1
2	= 0.2
3	= 0.3
4	= 0.4
5	= 0.5
6	= 0.6
⊗	= BAR AT OR ABOVE WATER SURFACE

MODEL SCALE IN FEET:

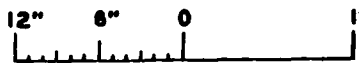

MEAD HYDRAULIC LABORATORY
MARINA STUDY
BED MAPS FOR COMBINATION ENTRANCE

202

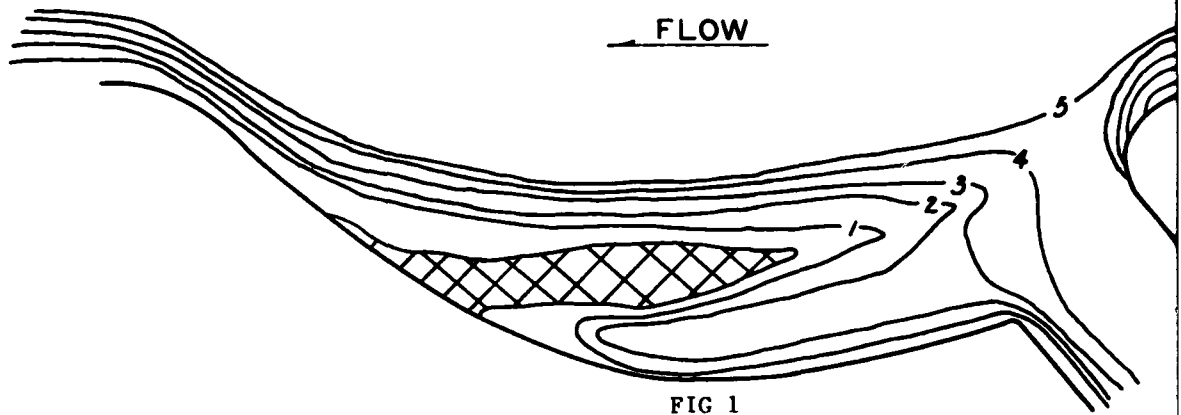

FIG 1
RUN 29 AT NORMAL STAGE
RUN TIME = 28.4 HOURS
FLOW

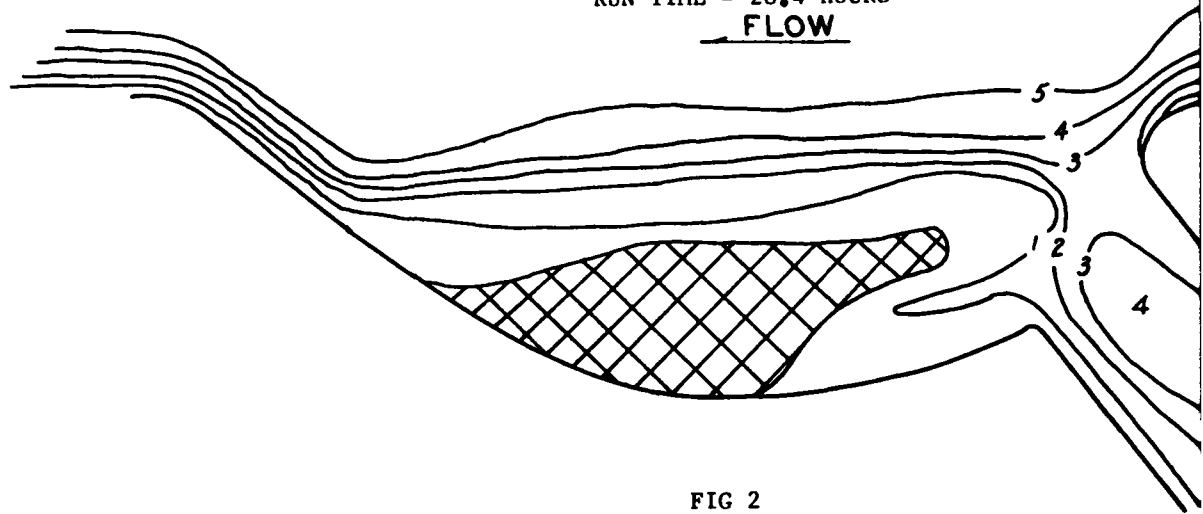

FIG 2
RUN 29 AT FLOOD STAGE
RUN TIME = 45.2 HOURS

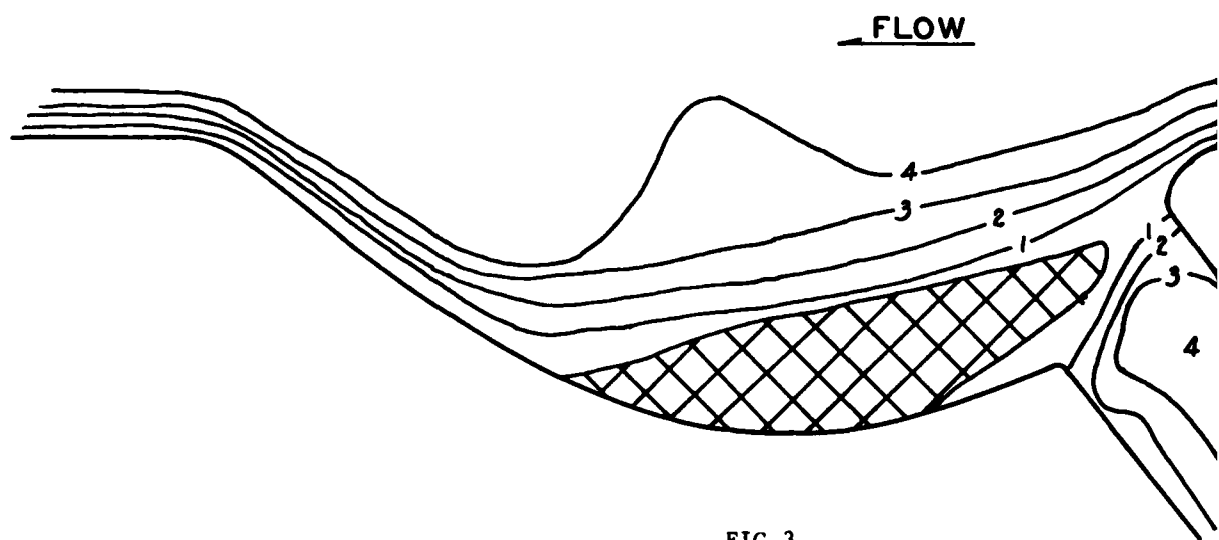
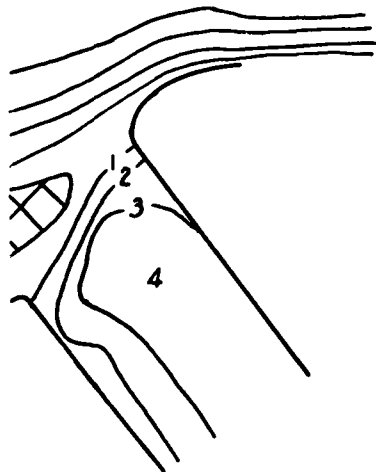
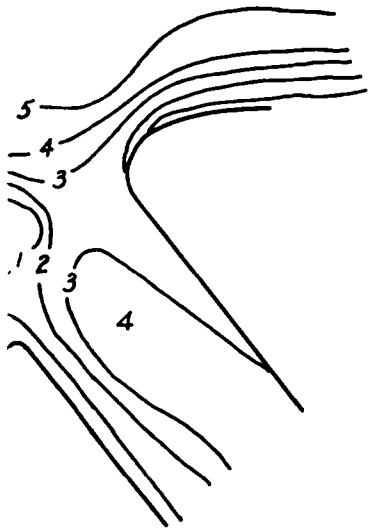
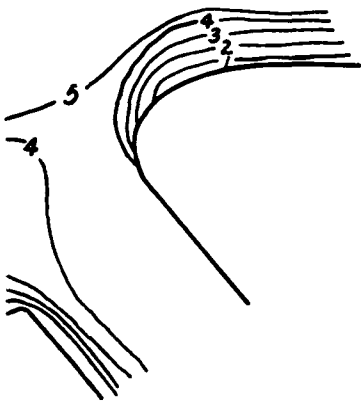

FIG 3
RUN 29 AT LOW STAGE
RUN TIME = 95.2 HOURS



LEGEND

CONTOUR NO.	DEPTH BELOW NWS, FT.
1	= 0.1
2	= 0.2
3	= 0.3
4	= 0.4
5	= 0.5

⊗ = BAR AT OR ABOVE WATER SURFACE

MODEL SCALE IN FEET:

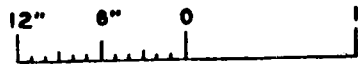

MEAD HYDRAULIC LABORATORY
MARINA STUDY
 BED MAPS FOR EGG-SHAPED MARINA

30/2

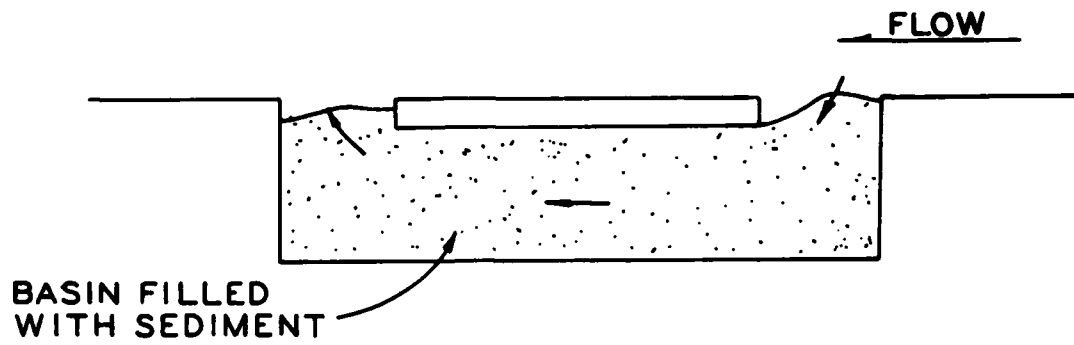

RUN 20
NO SCALE

MEAD HYDRAULIC LABORATORY
MARINA STUDY
DOUBLE ENTRANCE

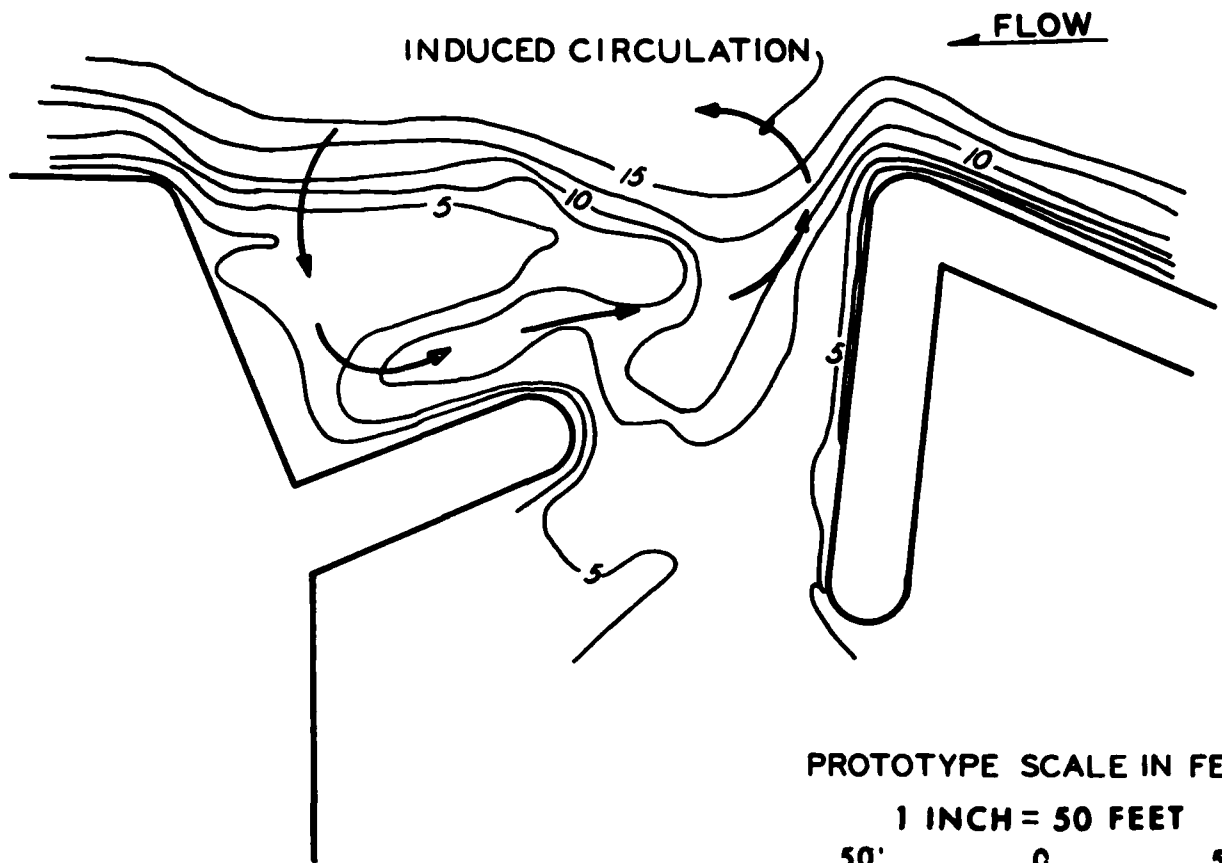

PROTOTYPE SCALE IN FEET:
 1 INCH = 50 FEET
 50' 0 50'

SOUNDING OF 6 OCT. 71

NOTE:
 CONTOUR INTERVAL = 2.5'
 CONTOURS INDICATE FEET
 BELOW NORMAL WATER
 SURFACE, NWS

MEAD HYDRAULIC LABORATORY
MARINA STUDY
 BED CONTOURS FOR
 SIOUX CITY MARINA

← FLOW

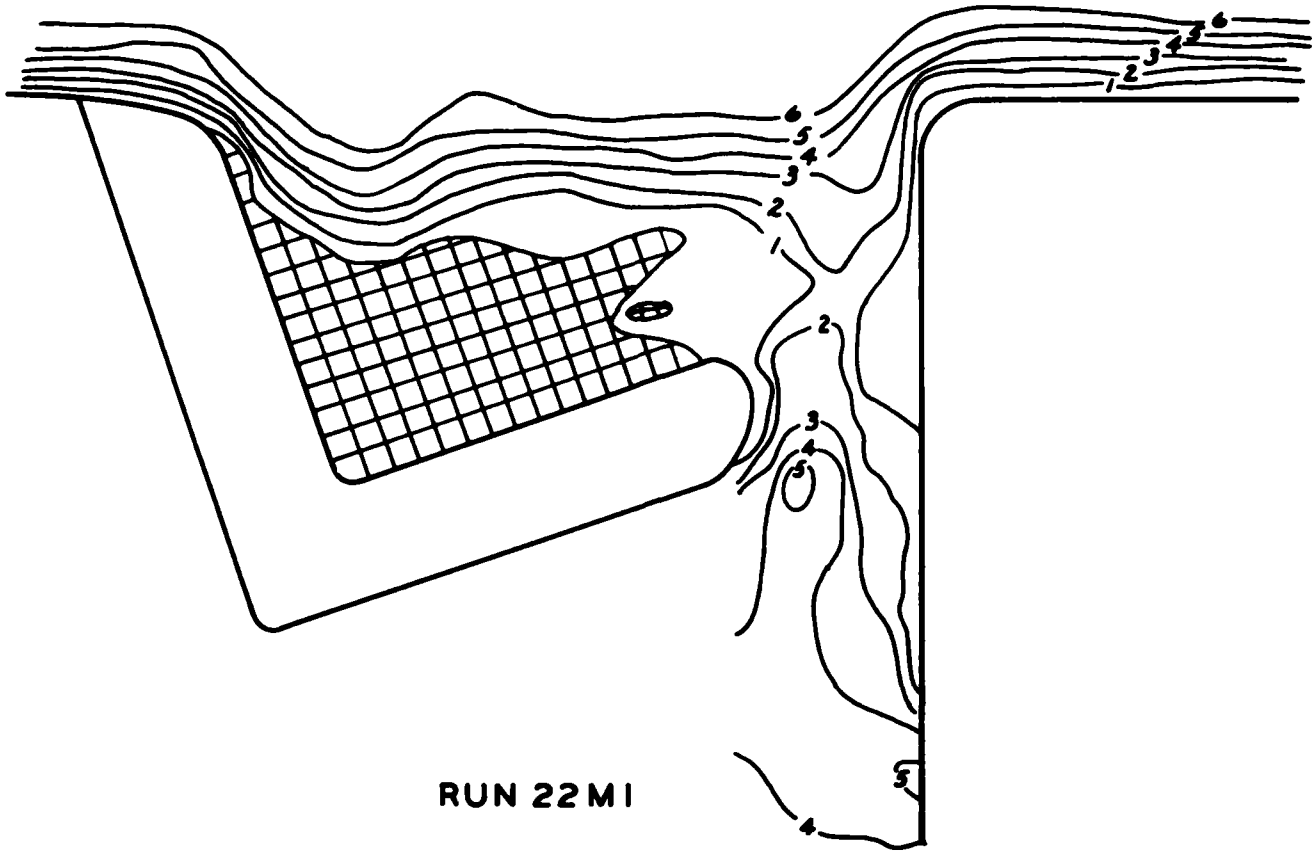

RUN 22 MI

LEGEND

<u>CONTOUR NO.</u>	<u>DEPTH BELOW NWS, FT.</u>
1	= 0.1
2	= 0.2
3	= 0.3
4	= 0.4
5	= 0.5
XX	= BAR AT OR ABOVE WATER SURFACE

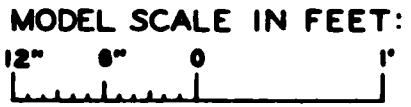

MEAD HYDRAULIC LABORATORY
MARINA STUDY
SIOUX CITY DESIGN
WITH NO UPSTREAM CONTRACTION

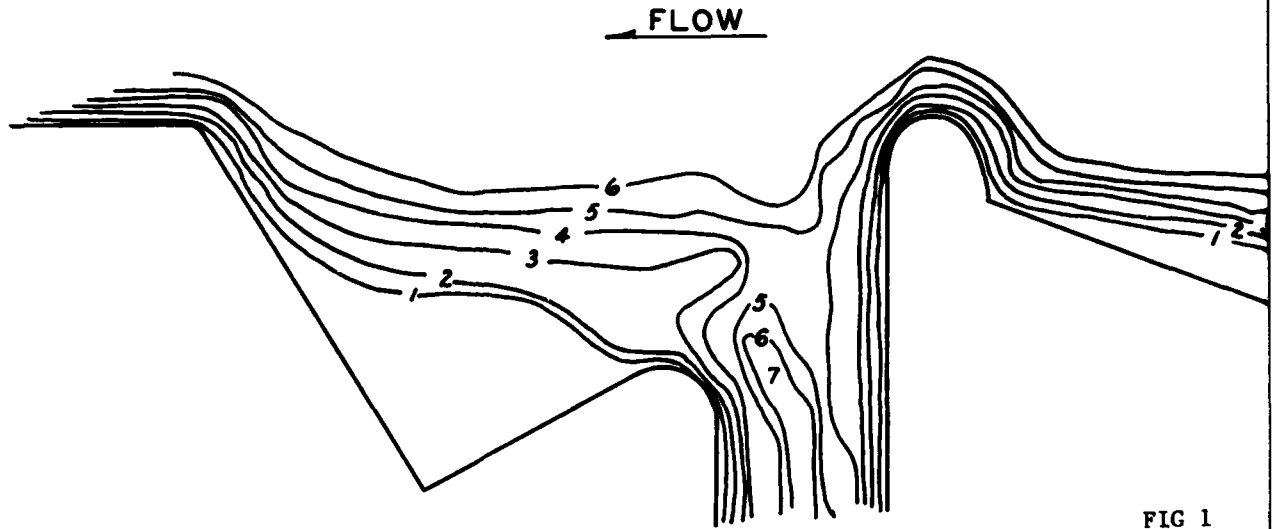

FIG 1
RUN 32, NORMAL ST
RUN TIME = 23.3 H

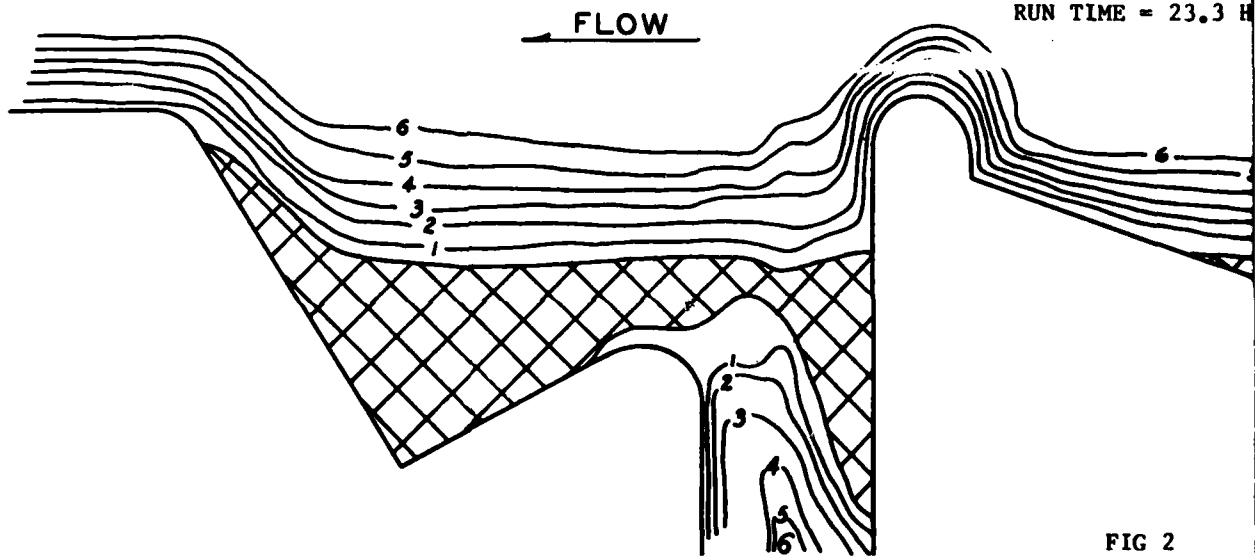

FIG 2
RUN 32, FLOOD STAG
RUN TIME = 40.5 H

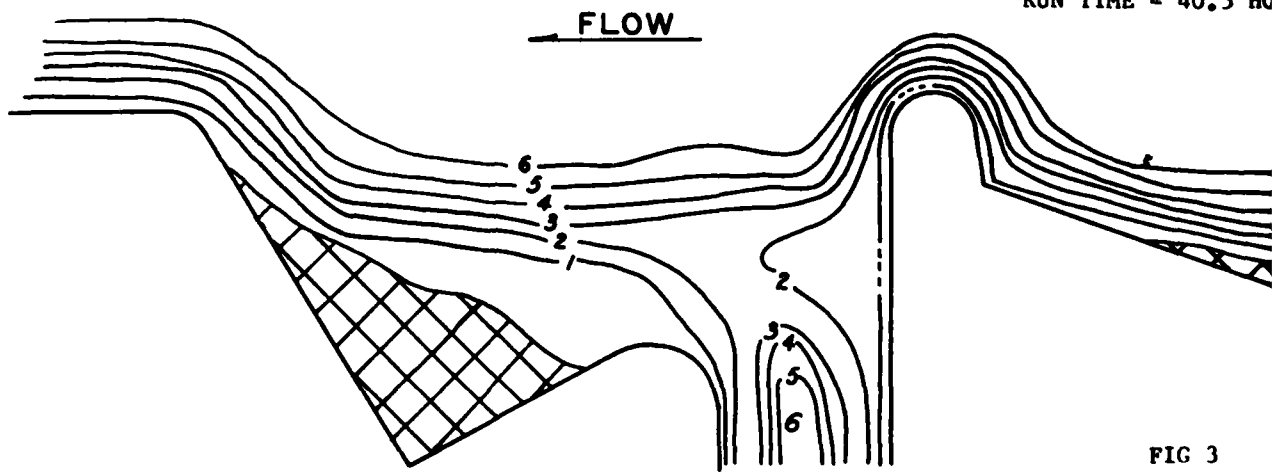

FIG 3
RUN 32, NORMAL ST
RUN TIME = 65.8 H

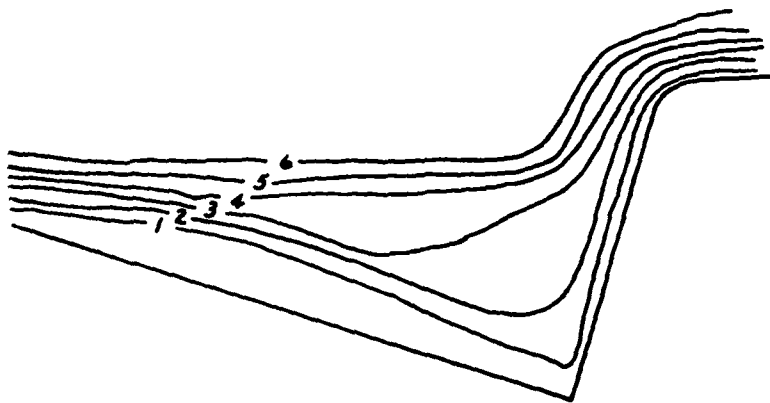

FIG 1
32, NORMAL STAGE
TIME = 23.3 HOURS

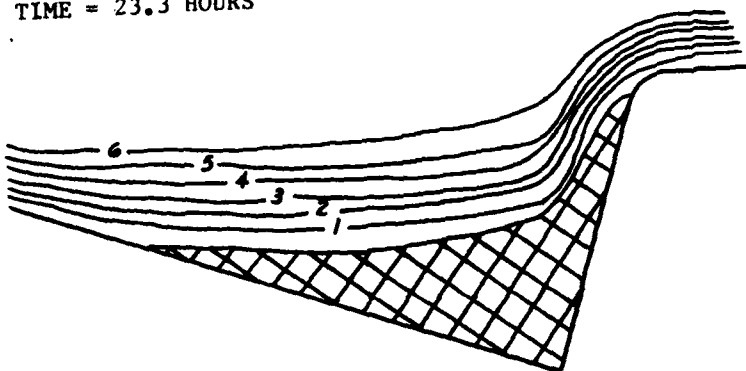

FIG 2
32, FLOOD STAGE
TIME = 40.5 HOURS

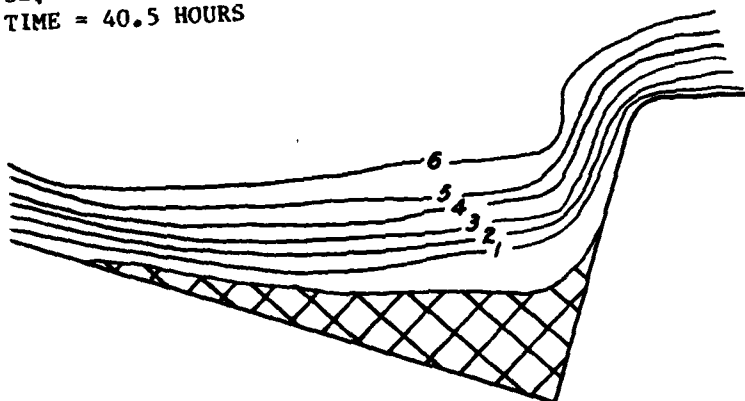
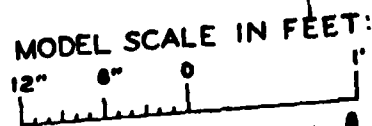

FIG 3
32, NORMAL STAGE
TIME = 65.8 HOURS

LEGEND

CONTOUR NO.	DEPTH BELOW NWS, FT.
1	= 0.1
2	= 0.2
3	= 0.3
4	= 0.4
5	= 0.5
6	= 0.6
7	> 0.7
⊗	= BAR AT OR ABOVE WATER SURFACE



MEAD HYDRAULIC LABORATORY
MARINA STUDY
 BED MAPS OF SIOUX CITY TYPE
 MARINA WITH PROJECTING SPUR DIKE

2 of 2

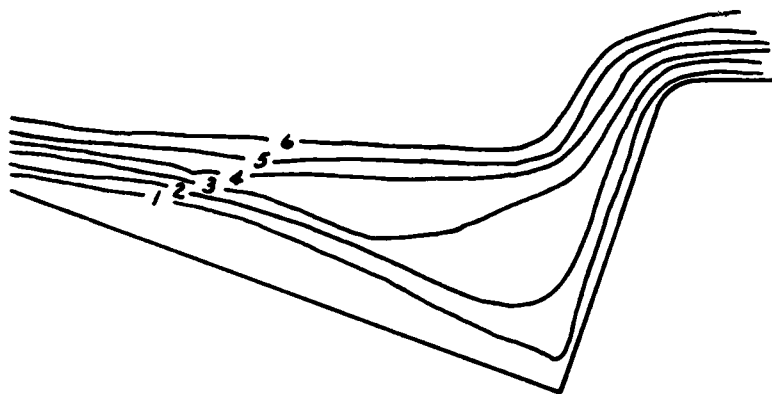

FIG 1
32, NORMAL STAGE
TIME = 23.3 HOURS

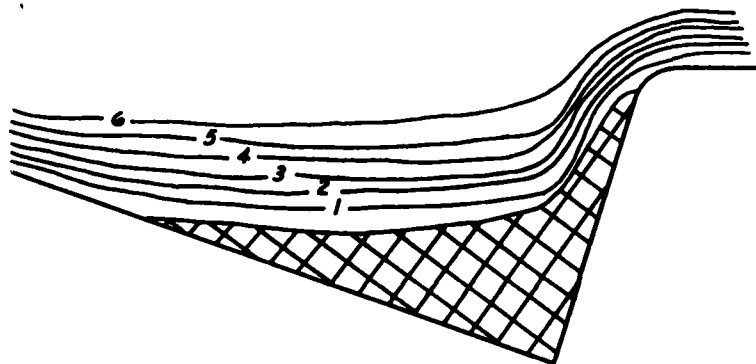

FIG 2
32, FLOOD STAGE
TIME = 40.5 HOURS

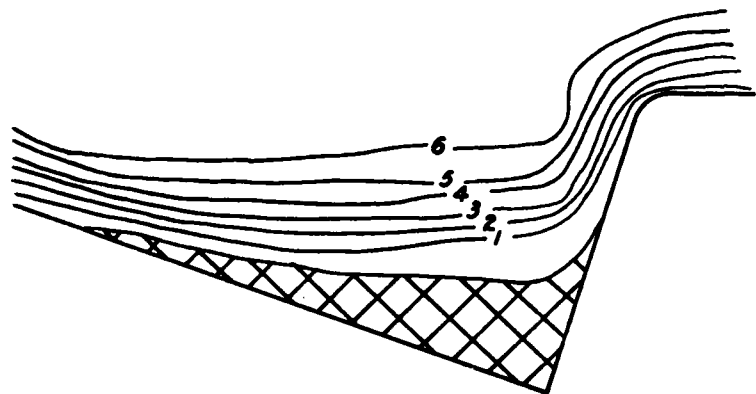
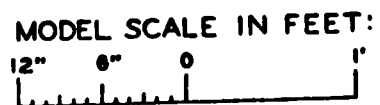

FIG 3
32, NORMAL STAGE
TIME = 65.8 HOURS

LEGEND

CONTOUR NO.	DEPTH BELOW NWS, FT.
1	= 0.1
2	= 0.2
3	= 0.3
4	= 0.4
5	= 0.5
6	= 0.6
7	> 0.7
⊗	= BAR AT OR ABOVE WATER SURFACE



MEAD HYDRAULIC LABORATORY
MARINA STUDY
BED MAPS OF SIOUX CITY TYPE
MARINA WITH PROJECTING SPUR DIKE

2 of 2

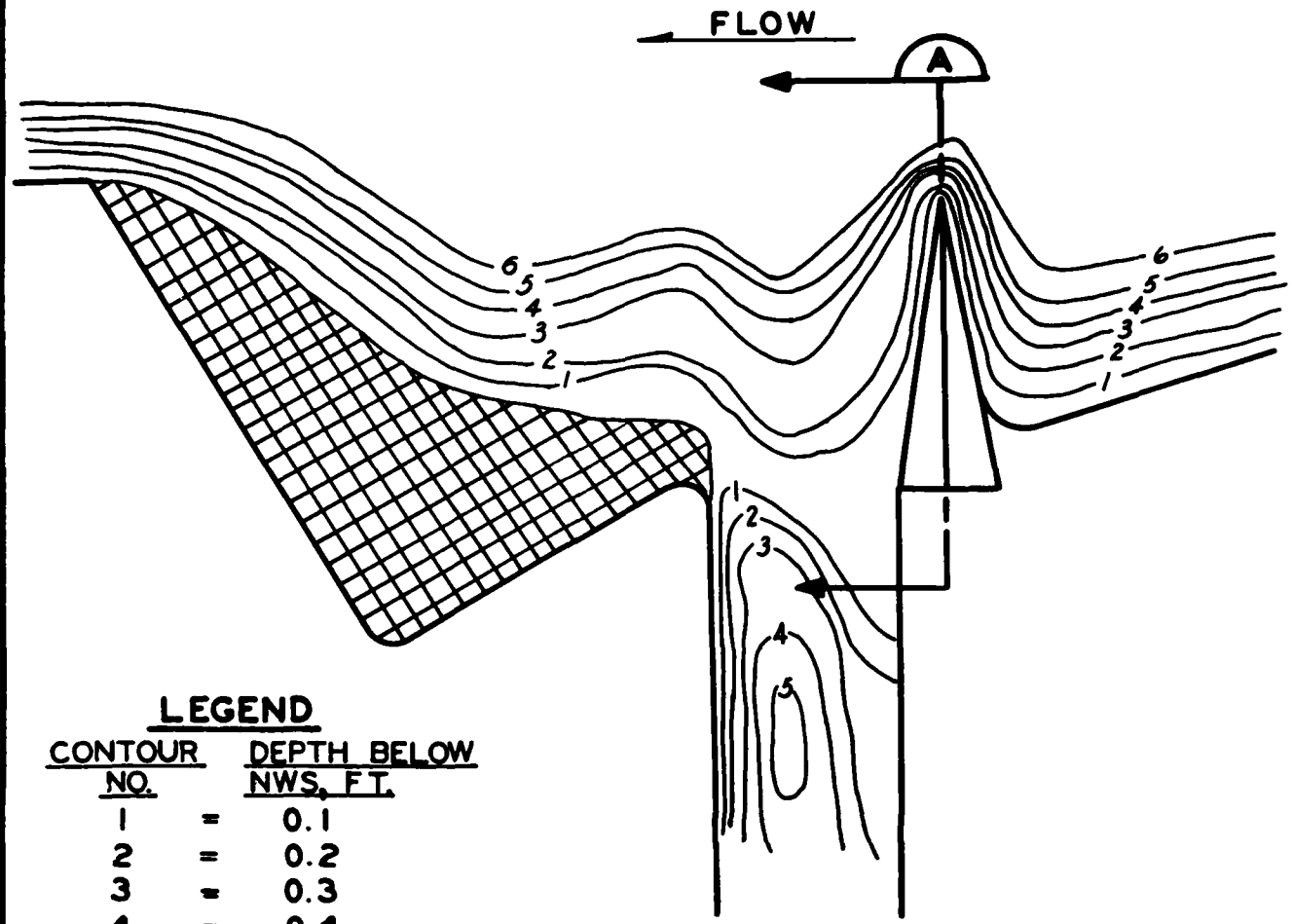

LEGEND

CONTOUR NO.	DEPTH BELOW NWS, FT.
1	= 0.1
2	= 0.2
3	= 0.3
4	= 0.4
5	= 0.5
6	= 0.6
⊗	= BAR AT OR ABOVE WATER SURFACE

MODEL SCALE IN FEET:

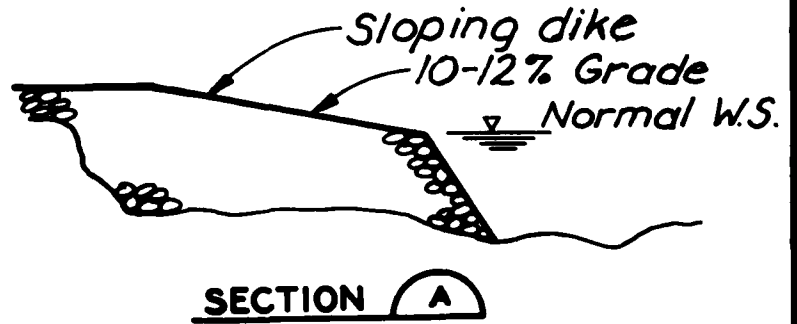

MEAD HYDRAULIC LABORATORY
MARINA STUDY
 BED MAP FOR SIOUX CITY DESIGN
 WITH SLOPING DIKE

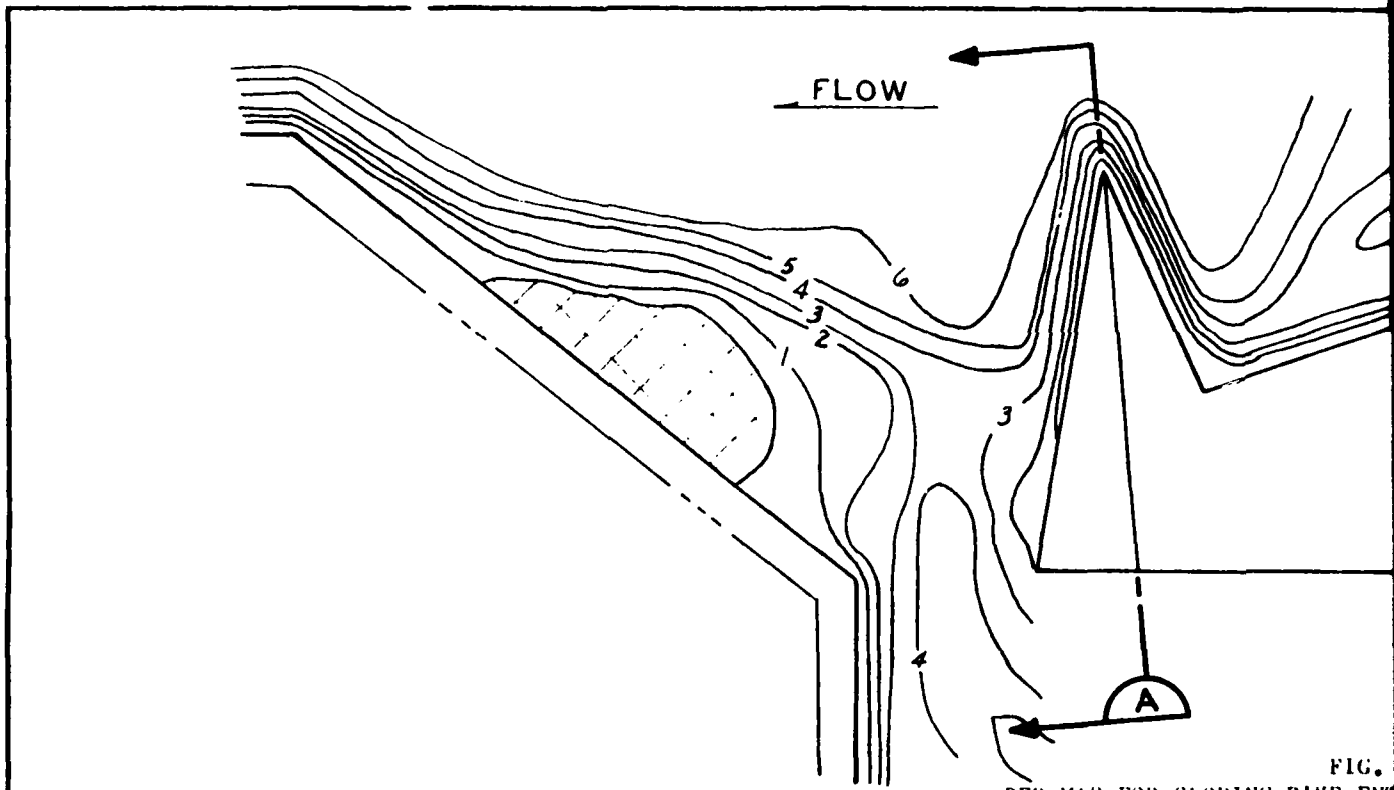

FIG. 1
BED MAP FOR SLOPING DIKE ENTRANCE
FLOOD STAGE. RUN TIME = 25.

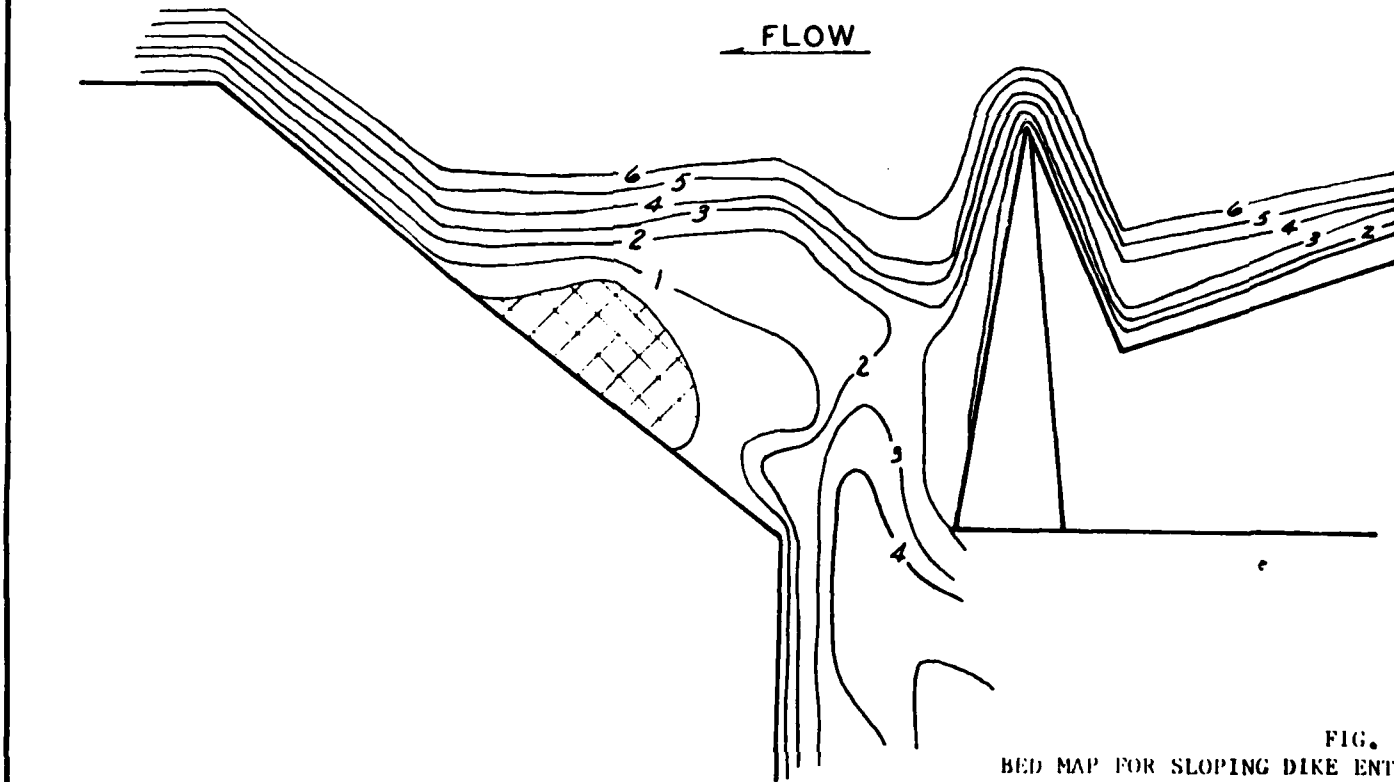
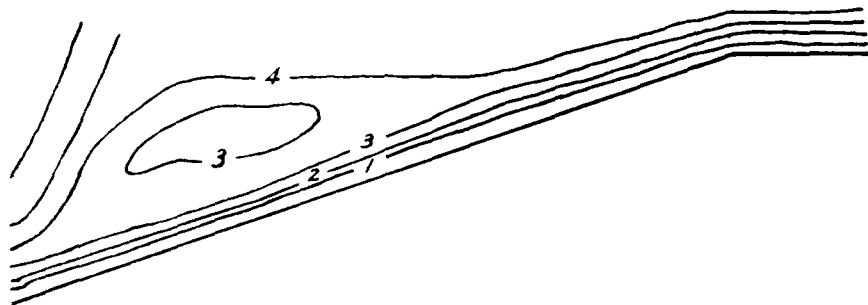

FIG. 2
BED MAP FOR SLOPING DIKE ENTRANCE
NORMAL STAGE. RUN TIME = 52.



LEGEND

CONTOUR NO.	DEPTH BELOW NWS, FT.
1	= 0.1
2	= 0.2
3	= 0.3
4	= 0.4
5	= 0.5
6	= 0.6
⊗	= BAR AT OR ABOVE WATER SURFACE

FIG. 1
SLOPING DIKE ENTRANCE FOLLOWING RUN 34
TIME = 25.3 HOURS

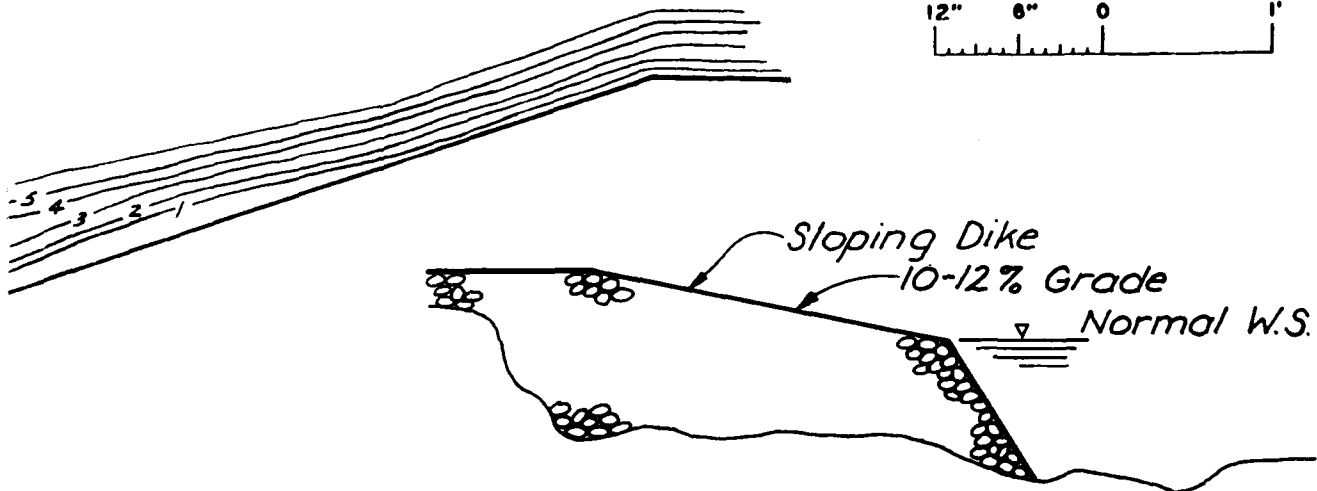
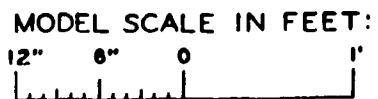

SECTION A
NO SCALE

FIG. 2
SLOPING DIKE ENTRANCE FOLLOWING RUN 34
TIME = 52.3 HOURS

MEAD HYDRAULIC LABORATORY
MARINA STUDY
SLOPING DIKE ENTRANCE STRUCTURE

W. J. O.

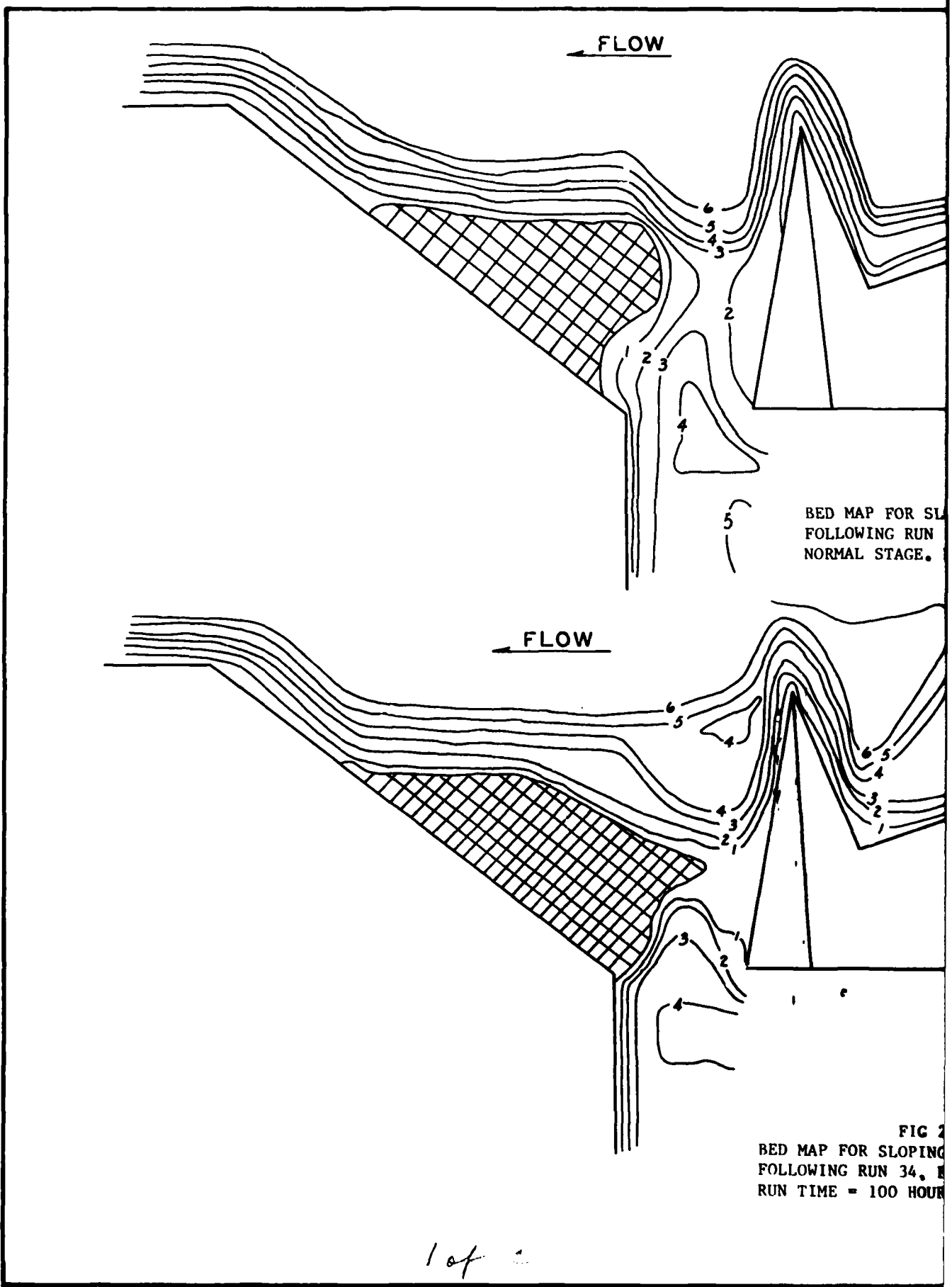

1 of 2

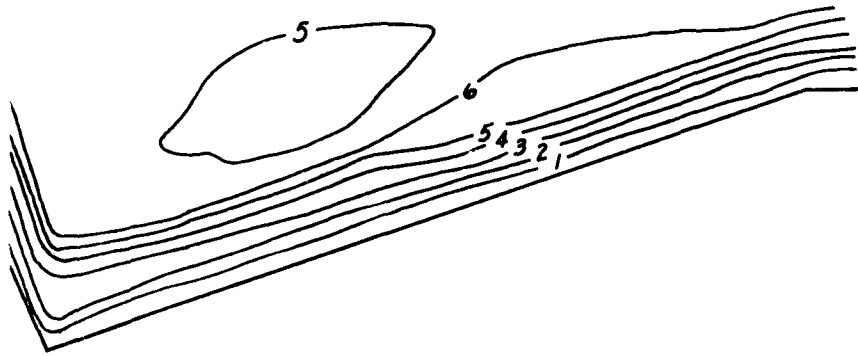

FIG 1
MAP FOR SLOPING DIKE ENTRANCE
FLOWING RUN 34 BETWEEN FLOOD AND
NORMAL STAGE. RUN TIME = 77.7 HOURS

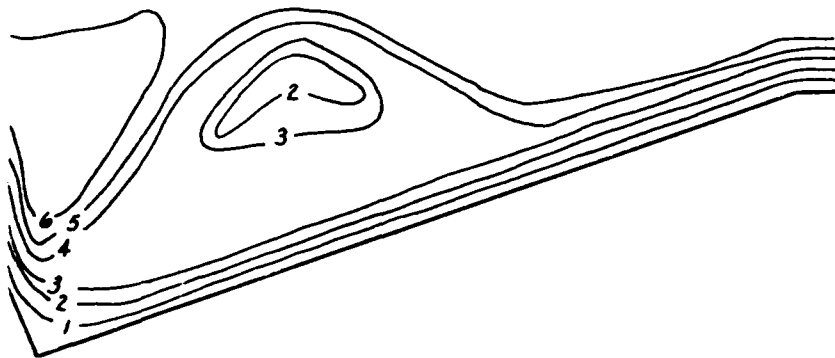

FIG 2
FOR SLOPING DIKE ENTRANCE
FLOWING RUN 34, FLOOD STAGE
RUN TIME = 100 HOURS

LEGEND

CONTOUR NO.	DEPTH BELOW NWS, FT.
1	= 0.1
2	= 0.2
3	= 0.3
4	= 0.4
5	= 0.5

⊗ = BAR AT OR ABOVE WATER SURFACE

MODEL SCALE IN FEET:



MEAD HYDRAULIC LABORATORY
MARINA STUDY
SLOPING DIKE ENTRANCE STRUCTURE

2 of 2

APPENDIX B

PHOTOGRAPHS



Photo 1. View looking upstream in model showing various entrance locations along model reach. Note arrows identifying marina types and their locations.

FLOW



Photo 2. Perpendicular entrance showing sediment deposition within entrance. Note bar across center of entrance.

FLOW



Photo 3. Run 29 combination entrance showing sediment deposition at normal stage following flood stage. Same run as Figure 3, plate 7. Note finger deposit extending across entrance in upper center of photograph.



Photo 4. Photo showing egg-shaped entrance during Run 29. Bed map for this photograph is on plate 8, figure 3, normal stage.



Photo 5. View of Sioux City type entrance with protruding spur dike upstream following flood discharge. Sediment deposition within "L" structure is typical for this configuration after flood discharges. Note gut that formed along leg of "L" structure.

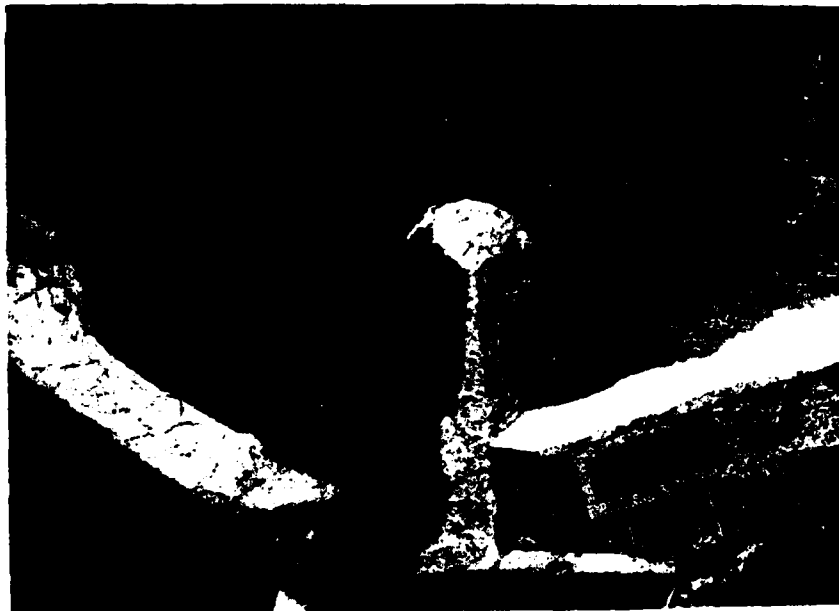

Photo 6. View of sloping spur dike following Run 34. Note sediment deposition downstream of sloping spur dike and small channel still remaining open. See plate 15, figure 1, bed map for contours.

APPENDIX C

REFERENCES

APPENDIX C

REFERENCES

1. SPATARU, A., "Silting Up of River Ports," Hydrotechnical Research Institute, Bucharest, Romania.
2. U.S. Army Corps of Engineers, "Shoaling in Harbor Entrances," Technical Report HL-79-5, March 1979.
3. U.S. Army Corps of Engineers, "Laboratory Investigation of Sioux City Boat Marina Entrance," MRD Hydraulic Laboratory Series Report No. 3, February 1967.
4. U.S. Army Corps of Engineers, "Operation and Function of the Mead Hydraulic Laboratory," MRD Hydraulic Laboratory Series Report No. 1, March 1969.
5. U.S. Army Engineer Division, Missouri River, "Suspended Sediment in the Missouri River," Daily Record for Water Years 1960-1964, October 1970.
6. U.S. Army Engineer District, Omaha, "Suspended Sediment in the Missouri River," Daily Record for Water Years 1965-1969, May 1972.
7. U.S. Army Engineer District, Kansas City, "Suspended Sediment in the Missouri River," Daily Record for Water Years 1970-1974, April 1976.

APPENDIX B
PHOTOGRAPHS



Photo 1. View looking upstream in model showing various entrance locations along model reach. Note arrows identifying marina types and their locations.

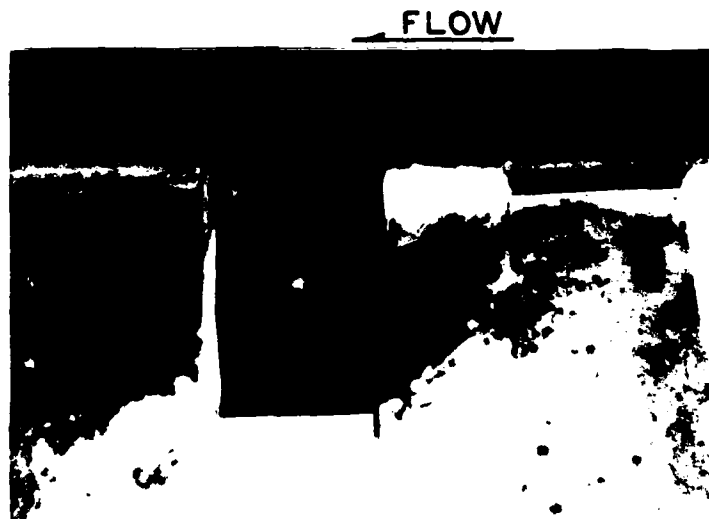

Photo 2. Perpendicular entrance showing sediment deposition within entrance. Note bar across center of entrance.

← FLOW



Photo 3. Run 29 combination entrance showing sediment deposition at normal stage following flood stage. Same run as Figure 3, plate 7. Note finger deposit extending across entrance in upper center of photograph.



Photo 4. Photo showing egg-shaped entrance during Run 29. Bed map for this photograph is on plate 8, figure 3, normal stage.



Photo 5. View of Sioux City type entrance with protruding spur dike upstream following flood discharge. Sediment deposition within "L" structure is typical for this configuration after flood discharges. Note gut that formed along leg of "L" structure.



Photo 6. View of sloping spur dike following Run 34. Note sediment deposition downstream of sloping spur dike and small channel still remaining open. See plate 15, figure 1, bed map for contours.

APPENDIX C

REFERENCES

APPENDIX C

REFERENCES

1. SPATARU, A., "Silting Up of River Ports," Hydrotechnical Research Institute, Bucharest, Romania.
2. U.S. Army Corps of Engineers, "Shoaling in Harbor Entrances," Technical Report HL-79-5, March 1979.
3. U.S. Army Corps of Engineers, "Laboratory Investigation of Sioux City Boat Marina Entrance," MRD Hydraulic Laboratory Series Report No. 3, February 1967.
4. U.S. Army Corps of Engineers, "Operation and Function of the Mead Hydraulic Laboratory," MRD Hydraulic Laboratory Series Report No. 1, March 1969.
5. U.S. Army Engineer Division, Missouri River, "Suspended Sediment in the Missouri River," Daily Record for Water Years 1960-1964, October 1970.
6. U.S. Army Engineer District, Omaha, "Suspended Sediment in the Missouri River," Daily Record for Water Years 1965-1969, May 1972.
7. U.S. Army Engineer District, Kansas City, "Suspended Sediment in the Missouri River," Daily Record for Water Years 1970-1974, April 1976.

END

FILMED

2-85

DTIC