

AD-A148 885

AN ALIGNMENT FIXTURE FOR A TWO-DEGREE-OF-FREEDOM (TDF)
GYROSCOPE(U) DEFENCE RESEARCH ESTABLISHMENT OTTAWA
(ONTARIO) R G APPS JUN 84 DREO-TN-84-5

1/1

UNCLASSIFIED

F/G 17/7

NL

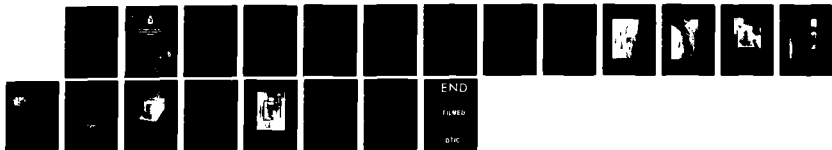

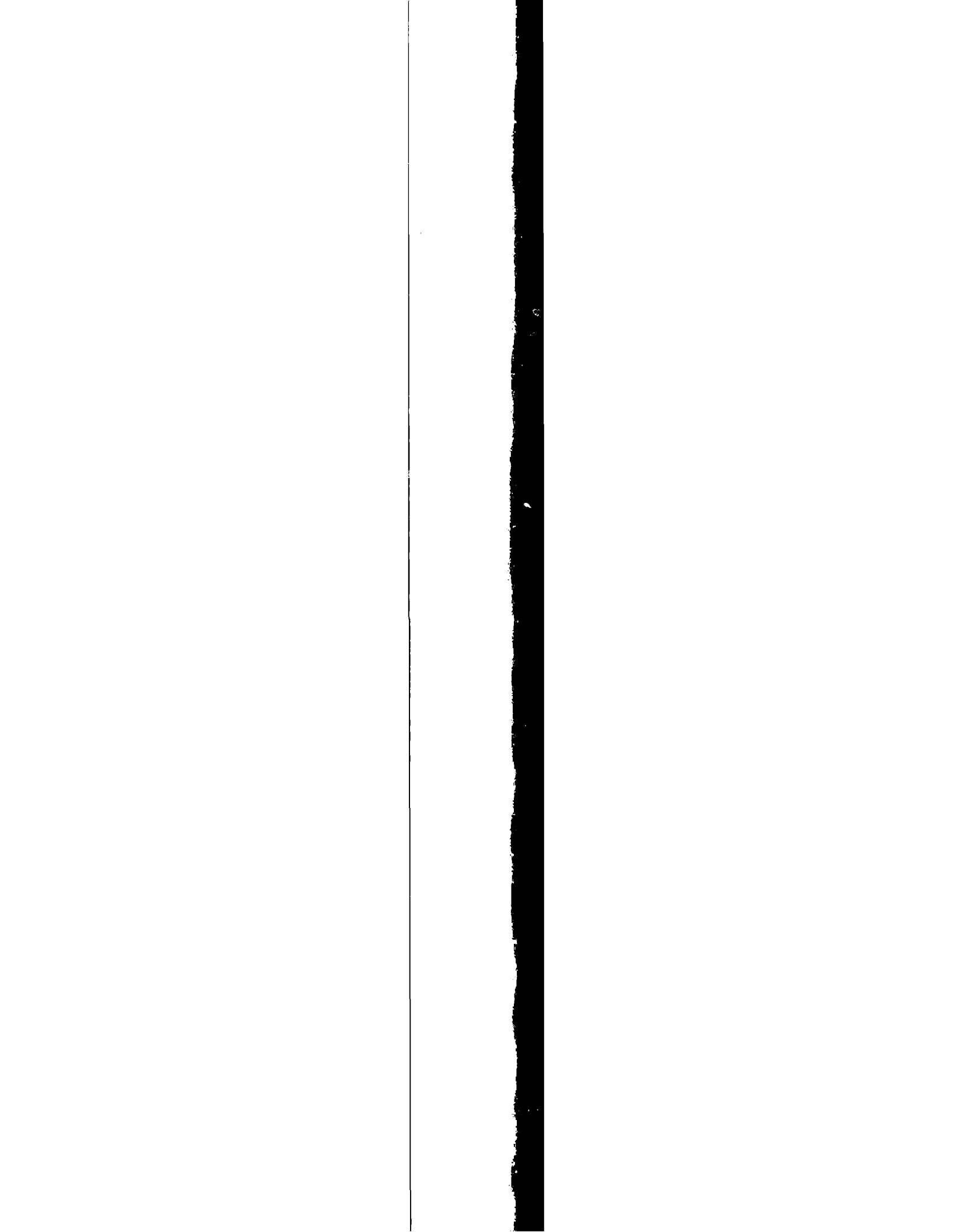

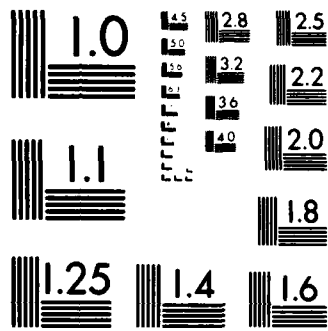

MICROCOPY RESOLUTION TEST CHART
NATIONAL BUREAU OF STANDARDS-1963 A

AD-A148 885

AN ALIGNMENT FIXTURE FOR A
TWO-DEGREE OF FREEDOM (DOF)
STRONG

E.O. 12958

DTIC
ELECTIC
JAN 03 1985
S
E

DTIC FILE COPY

DEFENCE RESEARCH ESTABLISHMENT OTTAWA
TECHNICAL NOTE 243

Canada

THE INFORMATION CONTAINED
HEREIN IS UNCLASSIFIED
DATE 11/19/01 BY 60322 UCBAW/STP

84 12 27 070



National Defence
Défense nationale

AN ALIGNMENT FIXTURE FOR A TWO-DEGREE-OF-FREEDOM (TDF) GYROSCOPE

by

R.G. Apps
*Electromagnetics Section
Electronics Division*

Accession For	
NTIS GRA&I	<input checked="" type="checkbox"/>
DTIC TAB	<input type="checkbox"/>
Unannounced	<input type="checkbox"/>
Justification	
By	
Distribution/	
Availability Codes	
Dist	Avail and/or Special
A-1	



DEFENCE RESEARCH ESTABLISHMENT OTTAWA
TECHNICAL NOTE 84-5

PCN
32G00

June 1984
Ottawa

This document has been approved
for public release and sale; its
distribution is unlimited.

ABSTRACT

A description of the Honeywell GG1111 Single-Degree-Of Freedom (SDF) strapdown gyroscope alignment fixture and its shortcomings are presented. The requirements for a new all aluminum alignment fixture for the Litton CSG-2 Two-Degree-Of-Freedom (TDF) strapdown gyroscope are discussed. A description of the new alignment fixture package is presented.

RESUME

Le système d'alignement du gyroscope à composants liés à un degré de liberté Honeywell GG1111 et ses inconvénients sont décrits. On discute de la nécessité d'un nouveau système d'alignement tout aluminium pour le gyroscope à composants liés à deux degrés de liberté Litton CSG-2. On décrit le nouveau système d'alignement.

TABLE OF CONTENTS

	<u>Page</u>
Abstract/Résumé.....	iii
1.0 HONEYWELL GG1111 SINGLE-DEGREE-OF-FREEDOM GYROSCOPE ALIGNMENT FIXTURE.....	1
1.1 Coarse Rotation Adjustment.....	1
1.2 Non Uniform Temperature Of Gyroscope And Poor Temperature Control.....	1
1.3 Coarse Tip And Tilt Adjustment.....	2
2.0 LITTON CSG-2 TWO-DEGREE-OF-FREEDOM STRAPDOWN GYROSCOPE ALIGNMENT FIXTURE.....	2
3.0 ALUMINUM TEMPERATURE CONTROLLED GYROSCOPE FIXTURE PACKAGE.....	2
3.1 Rotation Stage.....	2
3.2 Two Axis Tip And Tilt Positioner.....	3
4.0 ASSEMBLY OF THE GYROSCOPE ALIGNMENT FIXTURE FIXTURE	3
5.0 TEMPERATURE GRADIENT TEST.....	3
6.0 CONCLUSIONS.....	3
7.0 REFERENCE.....	4

1.0 HONEYWELL GG1111 SINGLE-DEGREE-OF-FREEDOM STRAPDOWN GYROSCOPE ALIGNMENT FIXTURE

1.0 For laboratory testing the Honeywell GG1111 strapdown gyroscope was mounted in a temperature controlled two element aluminum fixture which permitted alignment of the gyroscope with the test table. The upper element (gyroscope housing) allows rotation of the gyroscope, while the lower element provides the temperature control and tip and tilt adjustment (Fig. 1).

Three problems were encountered during alignment and testing of the gyroscope. First, too coarse a rotation adjustment in the upper element, second non-uniform temperature of gyroscope and poor temperature control and last, coarse tip and tilt adjustment in the lower element.

1.1 COARSE ROTATION ADJUSTMENT

Rotation of the gyroscope is achieved by loosening four Allen socket head screws on the front flange and manually rotating the gyroscope (Fig. 2). Because of various factors, an optimum accuracy of 0.005" of arc or 34 arc minutes is possible in a manual adjustment in rotation. An accuracy of 20 to 30 arc seconds is desirable.

1.2 NON UNIFORM TEMPERATURE OF GYROSCOPE AND POOR TEMPERATURE CONTROL

The operating temperature of the Honeywell GG1111 gyroscope is 185°F (85°C). This temperature is maintained by two heaters in the lower element of the fixture. (Fig. 1). Only one half of the gyroscope is encased in the upper element, leaving the other half exposed to the environment. A large temperature gradient was suspected between the encased and exposed ends of the gyroscope. Two thermistor sensors were strategically positioned, one was glued to the exposed body of the gyroscope near the leads, the other was glued to the fixture near the temperature control sensor. A temperature gradient test was performed with the fixture oriented in various positions. For each of the positions the temperature was allowed to stabilize for one hour before a reading was taken. An average 9 °C temperature gradient between the encased and exposed ends of the gyroscope was observed. Poor temperature control was achieved for two reasons; the control sensor was positioned too far from the heaters causing an overshoot. And second, one half of the gyroscope was exposed to the environment and should have been totally encased in a foam covered aluminum block.

1.3 COARSE TIP AND TILT ADJUSTMENT

The tip and tilt adjustment permits alignment of the gyroscope spin reference axis with the spin axis of the test table. This adjustment is provided by three spring loaded 1/4-20 Allen socket head bolts (Fig. 2). A 1/4-20 bolt has 20 threads per inch of length providing a displacement of 0.050" for each full revolution. This coarse adjustment makes the alignment of the gyroscope with the test table difficult.

2.0 LITTON CSG-2 TWO-DEGREE-OF-FREEDOM STRAPDOWN GYROSCOPE ALIGNMENT FIXTURE

For the laboratory testing of the Litton CSG-2 two-degree-of-freedom strapdown gyroscope a precise alignment fixture with good temperature control, stability and even heat distribution was required. A new three element mechanical fixture was designed. The package consists of an all aluminum temperature controlled gyroscope fixture, a rotation stage and a two axis tip and tilt positioner (Fig. 3).

3.0 ALUMINUM TEMPERATURE CONTROLLED GYROSCOPE FIXTURE

It was felt that the thermal gradients and temperature instability in the gyroscope could be dramatically reduced by encasing the gyroscope in a polyethylene foam covered aluminum block (DREO drawings no. 3530, 3531, 3532, 3533). In order to provide a uniform temperature distribution through the gyroscope, four evenly spaced 225 watt, 240 volt superwatt heaters were positioned around it's circumference (Fig. 4). The four heaters were wired in parallel and controlled with a 60 volt temperature controller providing 225 watts total heating power. Good temperature control and stability was achieved by positioning the temperature control sensor near a heater (Fig. 3), isolating the gyroscope fixture from the remainder of the package with quartz washers and 1/4" thick polyethylene foam padding, and covering the fixture with a 1/2" of polyethylene foam.

3.1 ROTATION STAGE

For the rotation of the gyroscope (alignment of the Y input axis west) an Opticon type TR-80 rotation stage 75 MM. Dia. X 35 MM. high complete with locking fine adjustment with an accuracy of 1 arc second and a sensitivity of 3 arc seconds was purchased (Fig. 5).

3.2 TWO AXIS TIP AND TILT POSITIONER

For the levelling of the gyroscope (alignment with the test table) a PI model P-044 two axis tip and tilt positioner with a working surface of 100 MM. X 100 MM. and a tilt range of $\pm 10^\circ$ was purchased (Fig. 6). The tip and tilt action of the gyroscope controlled by two micrometers each linked to the moveable tip and tilt positioning elements using spring coupling (Fig. 4). Because the combined weight of the rotation stage, the gyroscope and it's fixture compressed the original springs, a new more rigid set was installed.

4.0 ASSEMBLY OF THE GYROSCOPE ALIGNMENT FIXTURE PACKAGE

The PI two axis tip and tilt positioner was fastened to the three sided fixture with two 10-32 fillister socket head screws (Fig. 7). The rotation stage was positioned on the two axis tip and tilt positioner and held in place with four hold down clamps (Fig. 7). In order to mate the gyroscope fixture to the rotation stage, a stainless steel spacer adapter plate was machined (Fig. 8). The plate was fastened to the rotation stage with four 10-32 stainless steel flat head screws. The gyroscope fixture was then fastened to the spacer adapter plate with three stainless steel binding head screws with quartz spacer washers and 1/4" thick polyethylene foam padding. The quartz washers and the 1/4" foam padding reduce the heat transfer from the gyroscope fixture to the remainder of the package. The gyroscope fixture was covered with 1/2" polyethylene foam. The assembled alignment fixture package on the test table is shown in (Fig. 9).

5.0 TEMPERATURE GRADIENT TEST

A temperature gradient test was performed, the temperature of the CSG-2 gyroscope was monitored at the top center, belly band and bottom center. The temperatures were monitored during warm-up and until an operating temperature of 70.3°C was obtained. Temperatures observed after stabilization were top center 70.6°C , belly band 70.3°C and bottom center 70.0°C . The temperature gradient from the bottom center to the top center of the gyroscope is 0.6°C . Temperature stability at the belly band $70.3 \pm 0.05^\circ\text{C}$.

6.0 CONCLUSIONS

The requirements of a precise alignment fixture with good temperature control, stability and even heat distribution were met with the new fixture design. The temperature gradient through the gyroscope was reduced to 0.6°C from 9°C with the old fixture design. A temperature stability of $\pm 0.05^\circ\text{C}$ of set temperature was achieved.

REFERENCE

- A) R. Apps and M. Vinnins. Procedures For Static And Constant-Rate Tests On A Single-Degree-of-Freedom (SDF) Strapdown Gyroscope.

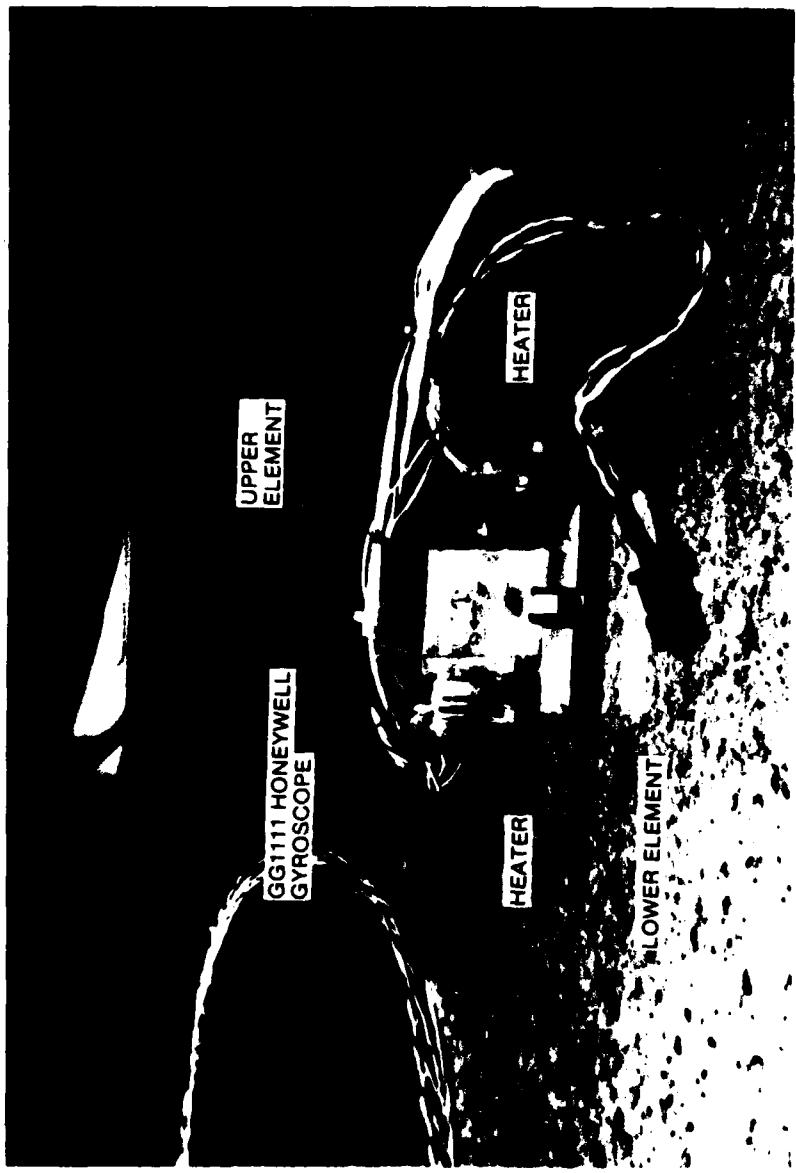

Fig. No. 1. GG1111 Mounted In Alignment Fixture



Fig. No. 2. GG1111 Gyro And Alignment Fixture

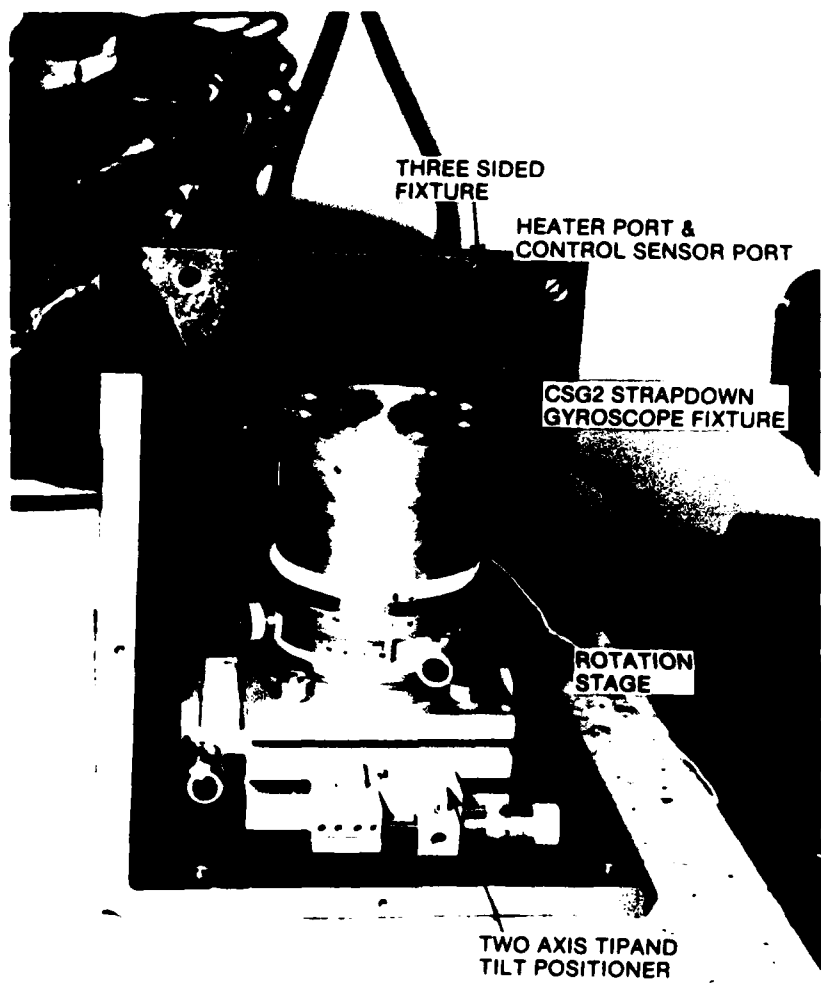

Fig. No. 3. Two-Degree-Of-Freedom Strapdown Gyroscope Alignment Fixture Package Mounted On A Three Side Fixture

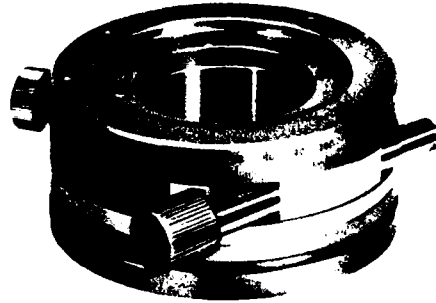

Fig. No. 4 Opened Gyroscope Fixture Showing Heater Ports

rotation stages type TR

O - origin of the vernier
(reading 1/60)

50



VIEW FROM
BOTTOM FACE

4 tapped holes
 $\varnothing V$, (ISO) $\varnothing P$

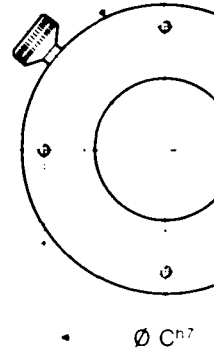

$\varnothing C^{H7}$

B
S
J
K

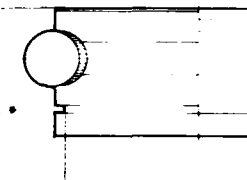

Neck for mounting
BR bridle

$\varnothing N$
 $\varnothing I$
 $\varnothing G$
 $\varnothing A$

	A	B	C	D	E	G	I	J	K	N	P	Q	S	T	W
TR 46	46	28	30	2	21.3	21	18	2	5	43	38	4	17.5	30	
TR 80	80	35	58	3	26.2	45	40	2	6	75	68	4.5	21.5	50	
TR 80S	80	18	58	2	13.5	55	50	2.5	3	75	68	—	16.8	38	
TR 120	120	42	84	3	32.5	70	64	3	8	114	105	5	26.5	62	
TR 160	160	60	120	4	46.3	100	90	3	10	150	140	6.7	40.5	84	

Fig. No. 5. Rotation Stages Type TR

Tip and tilt positioners

These positioners allow the mounted components to be inclined by an adjusted amount within the range $\pm 10^\circ$. **PI** tip and tilt positioners are available in the standard sizes 60×60 mm and 100×100 mm and any other sizes and allow tip/tilt. The tip and tilt motions are adjusted, the amount of angles measured by micrometers. The micrometers are each linked to the moveable tip and tilt positioning elements by using spring coupling. The axes of the tip and tilt positioners rest on ball bearings.

P-041 (Fig. 84 B) – **Tilt positioner** on one axis, base area and working surface 60×60 mm, tilt range $\pm 10^\circ$

P-042 (Fig. 84 C) – **Tip and tilt positioner** on two axes, size and tip and tilt range as in P-041

P-043 (Figs. 84 D, E) – **Tilt positioner** on one axis, base area and working surface 100×100 mm, tilt range $\pm 10^\circ$

P-044 (Figs. 84 F, G) – **Tip and tilt positioner** on two axes, size and tip and tilt range as in P-043

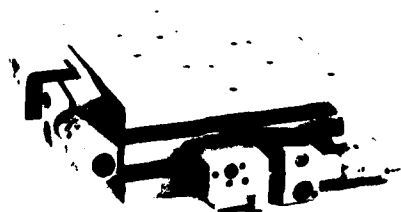

P-044

c

Fig. No. 6. Tip and Tilt Positioners

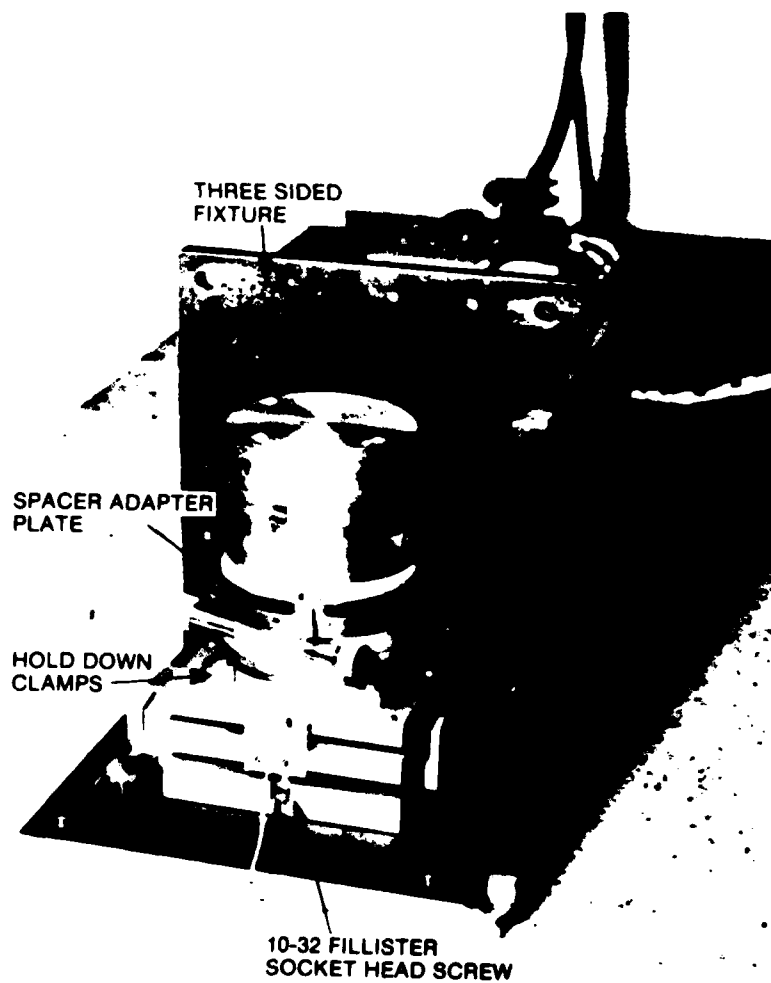
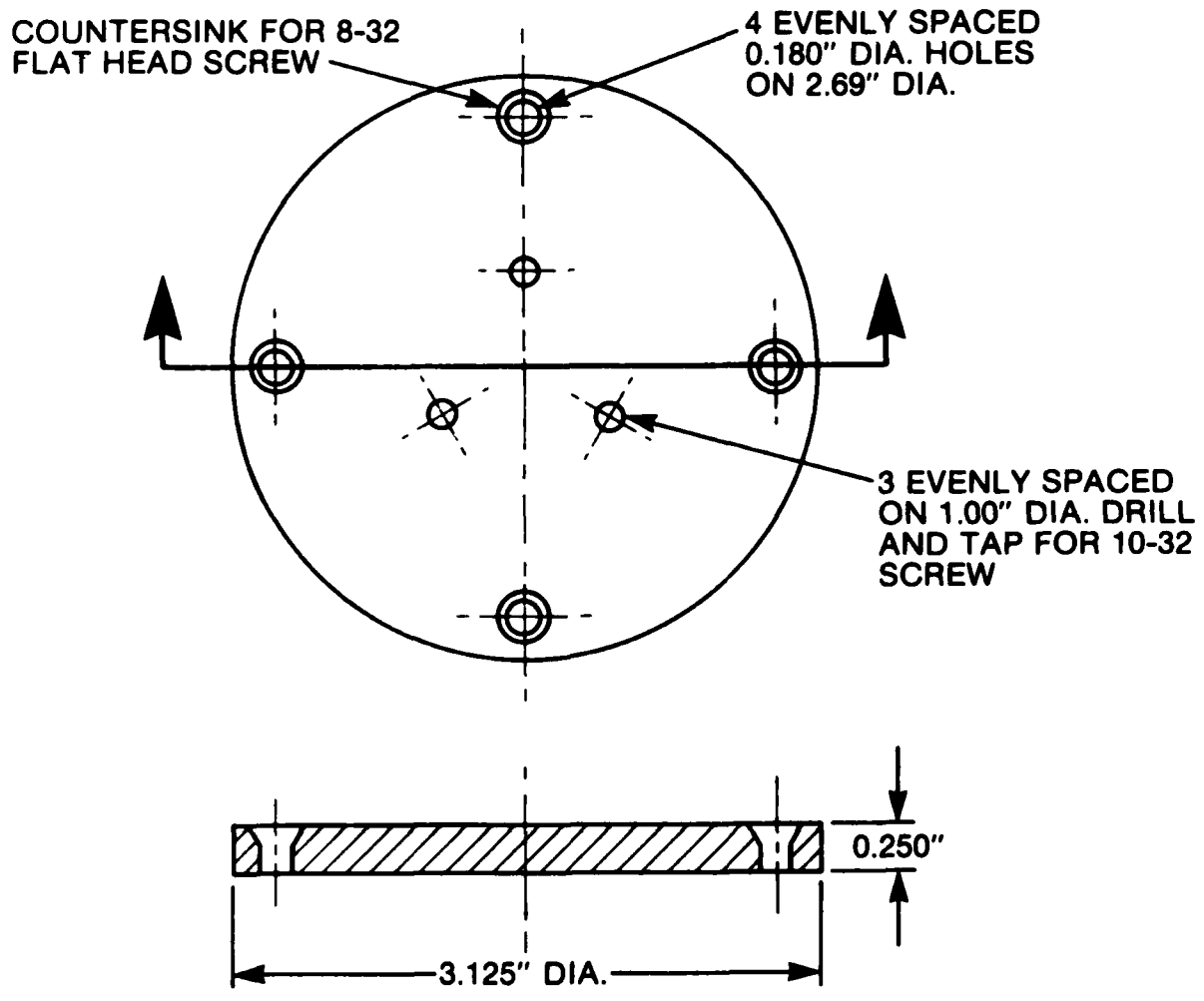

Fig. No. 7 Two-Degree-Of-Freedom Strapdown
Gyroscope Alignment Fixture Package
Mounted On A Three Sided Fixture



QUANTITY: 1
MATERIAL: STAINLESS STEEL

Fig. No. 8 Spacer Adapter Plate

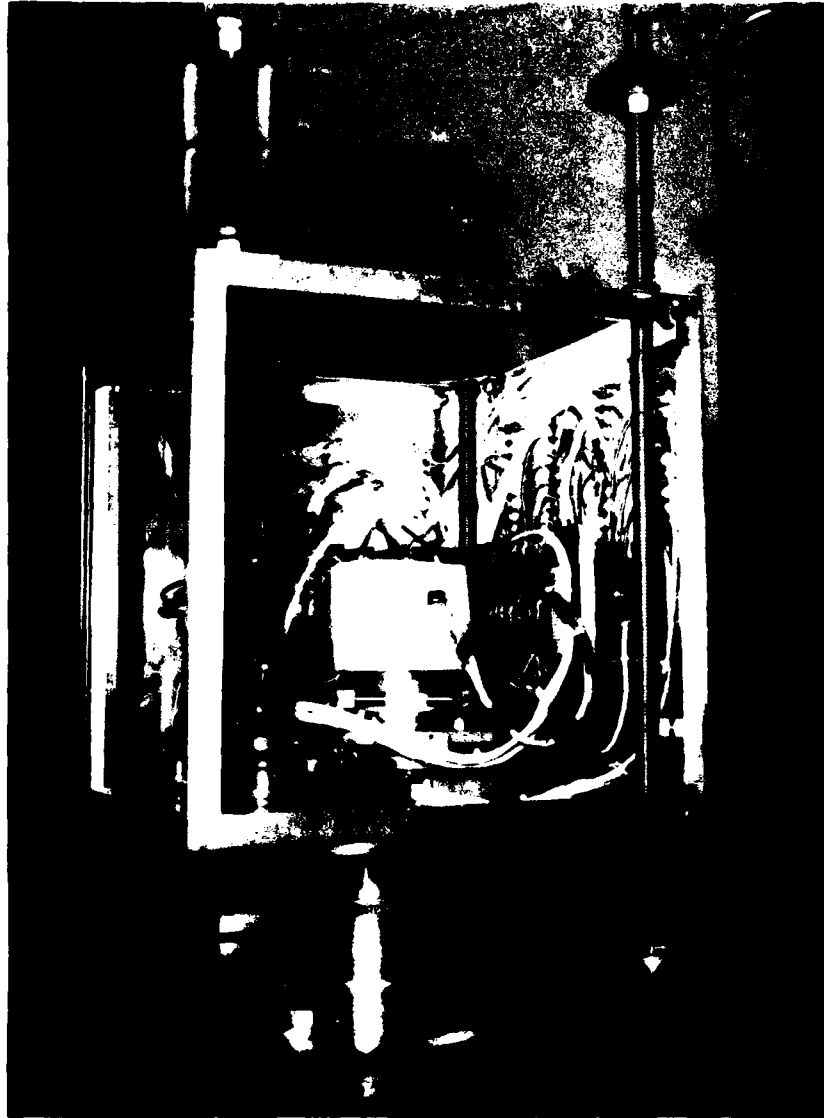

Fig. No. 9 Two-Degree-Of-Freedom Gyroscope
Alignment Fixture Package Mounted
On Test Table

UNCLASSIFIED

Security Classification

DOCUMENT CONTROL DATA - R & D		
Security classification of title, body of abstract and indexing annotation must be entered when the overall document is classified		
1. ORIGINATING AGENCY DEFENCE RESEARCH ESTABLISHMENT OTTAWA Department of National Defence Ottawa, Ontario K1A 0Z4, Canada		2a. DOCUMENT SECURITY CLASSIFICATION Unclassified
		2b. GROUP
3. DOCUMENT TITLE AN ALIGNMENT FIXTURE FOR A TWO-DEGREE-OF-FREEDOM (TDF) GYROSCOPE		
4. DESCRIPTIVE NOTES (Type of report and inclusive dates) Technical Note		
5. AUTHOR(S) (Last name, first name, middle initial) APPS, RENE, G.		
6. DOCUMENT DATE June 1984	7a. TOTAL NO OF PAGES 14	7b. NO. OF REFS
8a. PROJECT OR GRANT NO 32G	9a. ORIGINATOR'S DOCUMENT NUMBER(S) DREO TN 84-5	
8b. CONTRACT NO	9b. OTHER DOCUMENT NO.(S) (Any other numbers that may be assigned this document)	
10. DISTRIBUTION STATEMENT Unlimited		
11. SUPPLEMENTARY NOTES	12. SPONSORING ACTIVITY DREO	
13. ABSTRACT <p>(U) A description of the Honeywell GG1111 Single-Degree-Of Freedom (SDF) strapdown gyroscope alignment fixture and it's shortcomings are presented. The requirements for a new all aluminum alignment fixture for the Litton CSG-2 Two-Degree-Of-Freedom (TDF) strapdown gyroscope are discussed. A description of the new alignment fixture package is presented.</p>		

UNCLASSIFIED

Security Classification

KEY WORDS

Alignment Fixture

Two-Degree-of-Freedom (TDF) Gyroscope

INSTRUCTIONS

1. **ORIGINATING ACTIVITY** Enter the name and address of the organization issuing the document.
- 2a. **DOCUMENT SECURITY CLASSIFICATION** Enter the overall security classification of the document including special warning terms whenever applicable.
- 2b. **GROUP** Enter security reclassification group number. The three groups are defined in Appendix "M" of the DRB Security Regulations.
3. **DOCUMENT TITLE** Enter the complete document title in all capital letters. Titles in all cases should be unclassified. If a sufficiently descriptive title cannot be selected without classification, show title classification with the usual one-capital-letter abbreviation in parentheses immediately following the title.
4. **DESCRIPTIVE NOTES** Enter the category of document, e.g. technical report, technical note or technical letter. If appropriate, enter the type of document, e.g. interim, progress, summary, annual or final. Give the inclusive dates when a specific reporting period is covered.
5. **AUTHOR(S)** Enter the name(s) of author(s) as shown on or in the document. Enter last name, first name, middle initial. If military, show rank. The name of the principal author is an absolute minimum requirement.
6. **DOCUMENT DATE** Enter the date (month, year) of Establishment approval for publication of the document.
- 7a. **TOTAL NUMBER OF PAGES** The total page count should follow normal pagination procedures, i.e., enter the number of pages containing information.
- 7b. **NUMBER OF REFERENCES** Enter the total number of references cited in the document.
- 8a. **PROJECT OR GRANT NUMBER** If appropriate, enter the applicable research and development project or grant number under which the document was written.
- 8b. **CONTRACT NUMBER** If appropriate, enter the applicable number under which the document was written.
- 9a. **ORIGINATOR'S DOCUMENT NUMBER(S)** Enter the official document number by which the document will be identified and controlled by the originating activity. This number must be unique to this document.
- 9b. **OTHER DOCUMENT NUMBER(S)** If the document has been assigned any other document numbers (either by the originator or by the sponsor), also enter this number(s).
10. **DISTRIBUTION STATEMENT** Enter any limitations on further dissemination of the document, other than those imposed by security classification, using standard statements such as
 - (1) "Qualified requesters may obtain copies of this document from their defence documentation center."
 - (2) "Announcement and dissemination of this document is not authorized without prior approval from originating activity."
11. **SUPPLEMENTARY NOTES** Use for additional explanatory notes.
12. **SPONSORING ACTIVITY** Enter the name of the departmental project office or laboratory sponsoring the research and development. Include address.
13. **ABSTRACT** Enter an abstract giving a brief and factual summary of the document, even though it may also appear elsewhere in the body of the document itself. It is highly desirable that the abstract of classified documents be unclassified. Each paragraph of the abstract shall end with an indication of the security classification of the information in the paragraph (unless the document itself is unclassified) represented as (TS), (S), (C), (R), or (U).

The length of the abstract should be limited to 20 single spaced standard typewritten lines 7 1/2 inches long.
14. **KEY WORDS** Key words are technically meaningful terms or short phrases that characterize a document and could be helpful in cataloging the document. Key words should be selected so that no security classification is required. Identifiers, such as equipment model designation, trade name, military project code name, geographic location, may be used as key words but will be followed by an indication of technical context.

END

FILMED

2-85

DTIC

