

AD-A149 388

TOWED INSTRUMENT CABLE(U) OREGON STATE UNIV CORVALLIS  
TECHNICAL PLANNING AND DEVELOPMENT GROUP  
R MESECAR ET AL. OCT 81 TP/D-81-10 N00014-80-C-0881

1/1

UNCLASSIFIED

F/G 8/10

NL

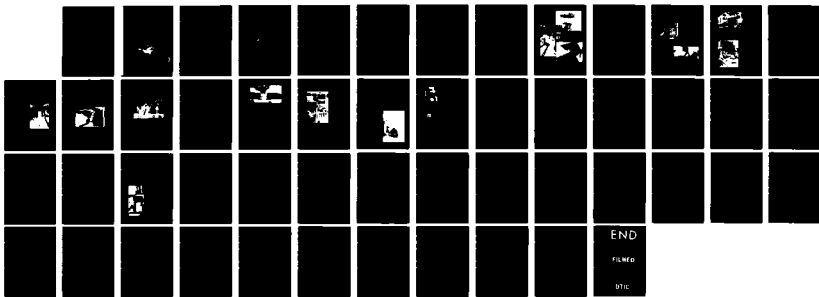

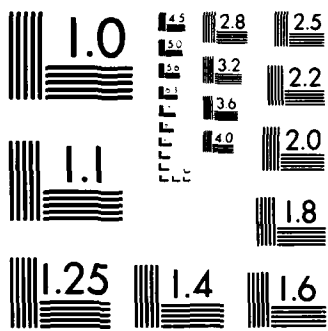

MICROCOPY RESOLUTION TEST CHART  
NATIONAL BUREAU OF STANDARDS-1963-A

1

AD-A149 388

# TOWED INSTRUMENT CABLE

by

Roderick Mesecar  
James Wagner

TECHNICAL PLANNING AND DEVELOPMENT GROUP  
School of Oceanography  
Oregon State University  
Corvallis, Oregon 97331



DTIC  
SELECTE  
DEC 18 1984  
B

October 1981

DTIC

**DISTRIBUTION STATEMENT A**  
Approved for public release  
Distribution Unlimited

Unclassified

SECURITY CLASSIFICATION OF THIS PAGE (When Data Entered)

| REPORT DOCUMENTATION PAGE  |   | READ INSTRUCTIONS<br>BEFORE COMPLETING FORM                    |
|--|---|--|
| 1. REPORT NUMBER<br>TP&D - 81 - 10   | 2. GOVT ACCESSION NO.<br>AD-A149388   | 3. RECIPIENT'S CATALOG NUMBER                                  |
| 4. TITLE (and Subtitle)<br>Towed Instrument Cable  | 5. TYPE OF REPORT & PERIOD COVERED<br>Engineering   | 6. PERFORMING ORG. REPORT NUMBER                               |
| 7. AUTHOR(s)<br>Roderick S. Mesecar<br>James Wagner  | 8. CONTRACT OR GRANT NUMBER(s)<br>N00014-80-C-0881  | 10. PROGRAM ELEMENT, PROJECT, TASK<br>AREA & WORK UNIT NUMBERS |
| 9. PERFORMING ORGANIZATION NAME AND ADDRESS<br>School of Oceanography<br>Oregon State University<br>Corvallis, Oregon 97331  | 11. CONTROLLING OFFICE NAME AND ADDRESS<br>Office of Naval Research<br>Department of the Navy<br>800 N. Quincy St.<br>Arlington, VA 22217 | 12. REPORT DATE<br>October 1981                                |
| 14. MONITORING AGENCY NAME & ADDRESS (if different from Controlling Office)<br>Ocean Programs Office, NORDA<br>Code 500, NSTL Station, MS 39529  | 13. NUMBER OF PAGES<br>46   | 15. SECURITY CLASS. (of this report)<br>unclassified           |
| 16. DISTRIBUTION STATEMENT (of this Report)<br>Approved for public release, distribution unlimited   |   |  |
| 17. DISTRIBUTION STATEMENT (of the abstract entered in Block 20, if different from Report)   |   |  |
| 18. SUPPLEMENTARY NOTES  |   |  |
| 19. KEY WORDS (Continue on reverse side if necessary and identify by block number)<br>Towed Instrument Cable<br>Towed thermistor chain<br>Seawater sensors<br>Faired Cable   |   |  |
| 20. ABSTRACT (Continue on reverse side if necessary and identify by block number)<br>Towed instrumentation has been developed for use in the marine research community to obtain profile measurements of some physical oceanographic parameters down to 165 m and over a lateral range. The Technical Planning and Development Group at Oregon State University, has been progressively expanding and improving the capability of a faired instrumented cable system that can be conveniently deployed and maintained by a small research team on a research vessel.<br>(continued over) |   |  |



# TOWED INSTRUMENT CABLE

(Distributed Instrumentation Profiling System, DIPS)

| <u>CONTENTS</u>  | <u>PAGES</u> |
|--|--------------|
| Introduction   | 1            |
| Background   | 2            |
| Winch System   | 5            |
| Instrumentation  | 11           |
| Sensors  | 14           |
| Conductivity Cell  | 17           |
| Future DIPS Design Considerations                                | 26           |
| Digital Sensor Module  | 31           |
| Winch Capacity   | 38           |
| <u>In situ</u> Signal Cable and Electronic<br>Module Connections | 40           |
| Conclusion   | 44           |
| References   | 46           |

# TOWED INSTRUMENT CABLE

Roderick Mesecar  
James Wagner

Oregon State University  
School of Oceanography  
Corvallis, OR 97331

## Introduction

Some current air-sea research programs are centered around the use of towed distributed instrumentation profiling cable (DIPS) (thermistor chain) to obtain observations of the thermal structure in the upper ocean as a function of depth and over a lateral range. The main objective of these programs is to obtain a better understanding of the dynamics of the mixed layers, internal waves, and oceanic fronts. DIPS has been developed to obtain profile measurements of some physical oceanographic parameters down to 165 m. As shown schematically in Figure 1, DIPS is instrumented to measure 30 vertical temperature stations, 4 pressure (depth) stations, and 6 seawater conductivity stations during a tow. The sensor stations can be repositioned along the cable at sea.

Since its adaptation/development in 1979, DIPS has been successfully deployed from a variety of research vessels by Oregon State University research personnel in five field programs: MILE, JASIN, FRONTS-80, Hawaii/Newport, and LOTUS-81. DIPS is of a modular design which provides for a degree of adaptable flexibility for use in other research applications.

The thrust of this report is to review the present technology used in the DIPS cable assembly and instrumentation system, and then make projections on the instrumentation technology for a towed cable with expanded capabilities.

## Background

Early in 1976, the Johns Hopkins Applied Physics Laboratory (APL) tested a thermistor chain that had been developed in collaboration with Fathom Oceanology, Ltd. and Sippican Corporation.<sup>1,2</sup> Their tests had confirmed a smaller and more manageable cable system was practical. The

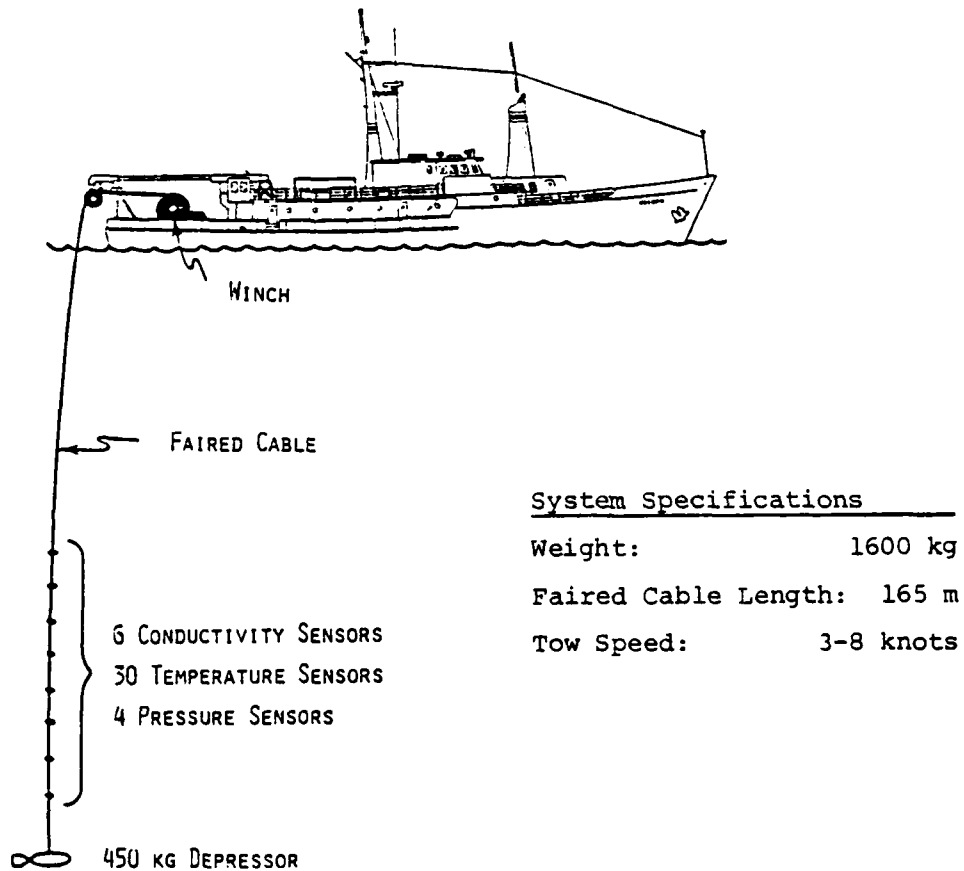

Figure 1. Schematic view of the deployed Distributed Instrumentation Profiling System (DIPS) with specifications.

cable system consisted of three major components: a winch drum design that could store the cable in a single layer, an instrumentation cable for coupling the in situ sensors to deck monitoring equipment, and a faired cable assembly to house the instrumentation cable during deployment. After their

cable system was reviewed, it was apparent that incorporated into the cable assembly was a components modularity that made it feasible for a small group to attain the same instrumented cable capability. The key technical feature of the APL cable which provided the modularity necessary for independent cable system development is incorporated in the cable fairing manufactured by Fathom Oceanology, Ltd. The fairing module uniquely functions as a retainer and protective sheath for the individual sensor signal wires to the surface. It also serves as a mounting for the sensors and a distributed coupling to the load-bearing tow cable. The model 770T fairing is supplied in three parts: a flexible polyurethane nosepiece that is free to swivel about the support cable and two rigid ABS plastic tailsections that can be screw-mounted to each other and socketed to the nosepieces. This modularity made it possible to isolate individual problems inherent in merging electro-mechanical design features when developing an instrumented cable system. Some obvious system design advantages provided by the fairing modules are:

- All subsystems (fairings, cable wire bundles, tension members, etc.) can be specified independently of each other, purchased, and assembled at a facility under the assembler's quality control.
- The fairing modularity permits a mechanical separation of the tension cable and signal wires.
- There is ready access to the signal wire bundles by simply unscrewing the fairing parts.
- Sensors can be integrated into the fairings.
- Sensors can be readily moved to new locations.
- The fairings provide reduced cable drag.

Figure 2 is an illustration of how the electrical instrumentation cable is merged with the steel support cable into the fairing module during assembly with later storage on the winch drum. Each fairing is approximately 10 cm high, 2 cm thick, and 15 cm long. The present electrical cable is

Figure 2a. The three pre-bundled electrical cable reels are shown on the left and the 1/2 in. steel support cable reel on the right. The cable clamp assembly jig is in the foreground.

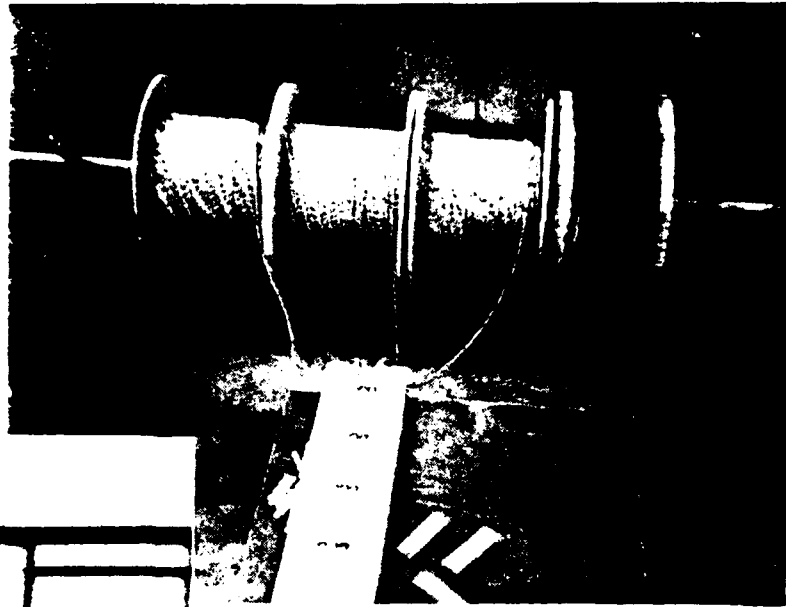

Figure 2c. Once the fairing shrouds are in place around the electrical and mechanical cables, the completed assembly is wound directly on the drum. Sensors are put on later.

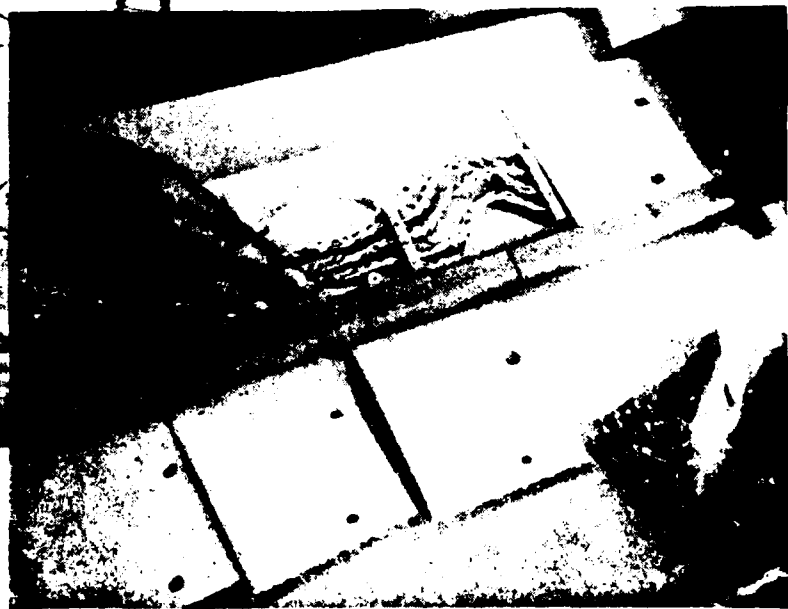

Figure 2b. Once the electric cables are clamped they are placed into the fairing halves and secured. Notice the nose sections are used to form the flexible coupling between the adjoining fairings.

composed of three bundles of 19-pair twisted signal wires. It is through these color coded, number 30 wire gauge signal wires that power to, and signals from, the sensors are transmitted. As shown in Figure 2b, the bundles are clamped once in each fairing and at spacings to incorporate a relief loop which allows the fairing tails to part when passing over the drum or the sheave. The nose sections form the vertical support mechanism from fairing to fairing with the steel cable being the support cable for the dead weight and electrical cable about which the nose sections pivot. On lengths of faired cable less than 100 m, the nose section appears to be an adequate support member. However, for longer lengths of faired cable the nose sections will stretch under load and contribute to the failure of the fairing mounting tips to the nose sections. To eliminate this stretching of the nose sections, mechanical stops are placed on the steel cable at intervals of every 30 fairings. The stops consist of 3-cm-long sections of copper tubing crimped to a final diameter of 2 cm. Other sizes of fairings are manufactured. However basic the fairing concept is to the modularity of the towed system, its size is dictated by the size of the instrumentation cable, the support cable, and possibly by the instrumentation sensor modules.

The electrical and mechanical cables were enclosed in the fairing assemblies in 3-m sections and then rolled onto the winch for storage as shown in Figure 2.

#### Winch System

Winches are generally custom designed to reflect the character of their application and the DIPS winch is no exception. The DIPS winch is 1.3 m in diameter with the capacity to store 165 m of the assembled cable system. The photographs in Figure 3 show a winch assembly scheme that can hoist

700 kg at fixed speeds of 15 or 30 cm/s. Once the deadweight cable depressor and faired cable deployment has been initiated, only one winch operator is necessary. A 10-m cord on the motor control wand allows the operator freedom to completely circle the winch. The payout rate of the cable is done under control of the motor drive train.

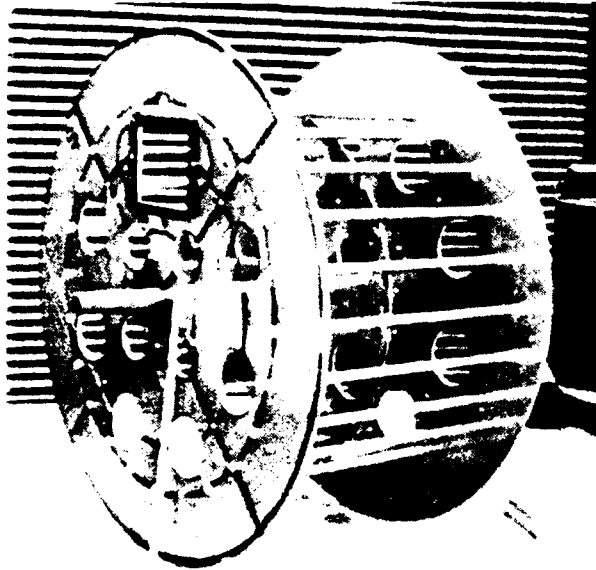
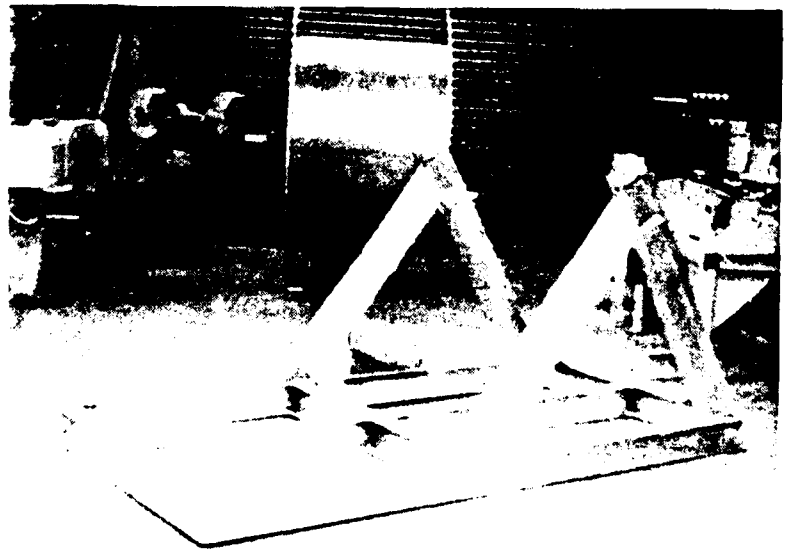

Figure 3a. The cable drum support discs were cut round with a metal band saw. Next, the discs were gang drilled for all the hole patterns. Twenty-four holes in the discs serve as sockets for the spacer rods that form the drum support structure. A metal inert gas (MIG) welder is used to weld the rods to the discs. A 70-mm thick skin is clamped over the support rods and welded as seen in Figure 3b.

Figure 3b. The winch base is made from 12.5 cm structural "I" beam stock that has been cut on the band saw and welded into a box frame. The drum rotates on a 7.6 cm OD by 1.27-cm-thick wall steel shaft which is supported by pillow blocks that bolt to the base frame. The shaft is keyed to the drum, but it is not the drive attachment for the power train. The power train drives a sprocket attached to one of the discs.



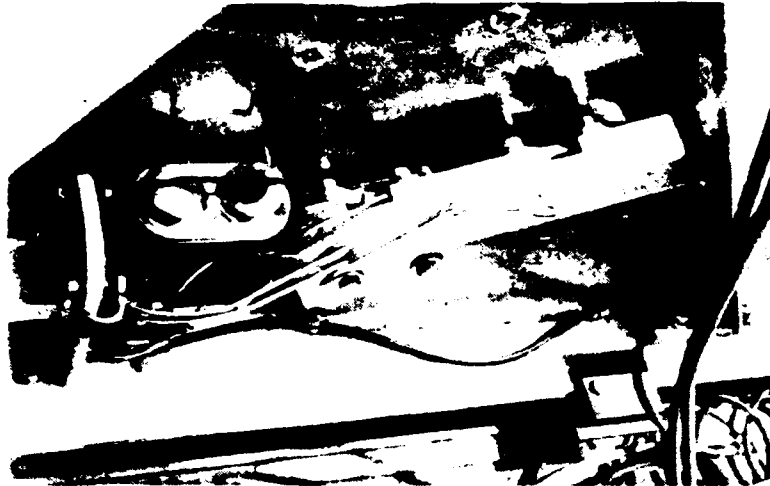

Figure 3c. Hydraulic automobile disc brakes, operating at the outer periphery on one of the drum discs, provide the drum breaking function. Two disc brake assemblies and a master cylinder are securely attached to the base frame. The brake control, which includes an electric cutout to the motor, can be manually operated from either side of the winch.

A manually operated disc brake system, as shown in Figure 3c, can be used to control cable payout when the motor control is off or the drum is to be locked up. This brake can be reached from either side of the winch. In the event that the drum drive chain parted, a mechanical deadfall would lock up the drum.



Figure 4. The completed winch has a capacity for 165 m of faired cable on the drum. The operator's pedestal is mounted over the power train. From this position the operator can inspect the fairing as it is being spooled. This fairing does not require a fair lead system. The lay of the cable is determined by a preformed plastic groove cemented to the drum surface. With the exception of the power train the majority of the winch is made of aluminum.

Bonded to the winch drum surface is a plastic extrusion contoured to mate with the radius of the fairing nosepieces. This extrusion circles around the drum, similar to a LEBUS groove, and functions to protect the shape of the nosepiece and guide the lay of the fairings.

The upper ends of the signal wire bundles are fed through a water blocked feed-through into a function box located within the winch drum. From barrier strips in the junction box, signal wires are branched. One branch is a connector mounted into the side of the drum. This connector port can be used to connect a cable to the surface electronic data systems; however, it has to be disconnected each time the winch is powered to move the faired cable.

A capability was added later that makes it possible to keep the signal wires electrically coupled to the surface data system while the winch is being powered. The mechanism that accomplishes this function is called a "sidewinder" and is similar to a design for an equivalent function manufactured by Fathom Oceanology, Ltd. The second branch from the junction box is connected to the sidewinder (shown in Figure 5) with a jacketed 50-pair cable.

The sidewinder consists of two coaxial drums, a slipclutch/racket drive assembly, and a transfer sheave. One drum is attached to, and rotates with, the winch drum. The second drum does not rotate and is attached to the winch frame with a torque arm. In Figure 4, the sidewinder is in a shipping cradle position with the torque arm resting on the winch shaft. In use, the sidewinder mounts on the drum shaft and appears as shown in Figure 5. As the winch rotates, the 50-pair cable is transferred from the rotating drum to the stationary one by the slipclutch assembly and transfer

sheave. This mechanism permits the winch to rotate and still keep solid signal wire connections from the sensors to the surface electronics.

In three years of operation, the sidewinder has proven reliable and quite functional. The only degradation of system performance which might be attributed to its use is a slight increase in susceptibility to ship radio operations, which is probably due to the increased length of cabling involved on deck.

Figure 5. The sidewinder mechanism couples to the winch shaft and functionally serves as a set of electrical sliprings for the 80 pairs of signal wires in the faired cable that pass through the rotating drum to the surface electronics located in the research vessel laboratory.

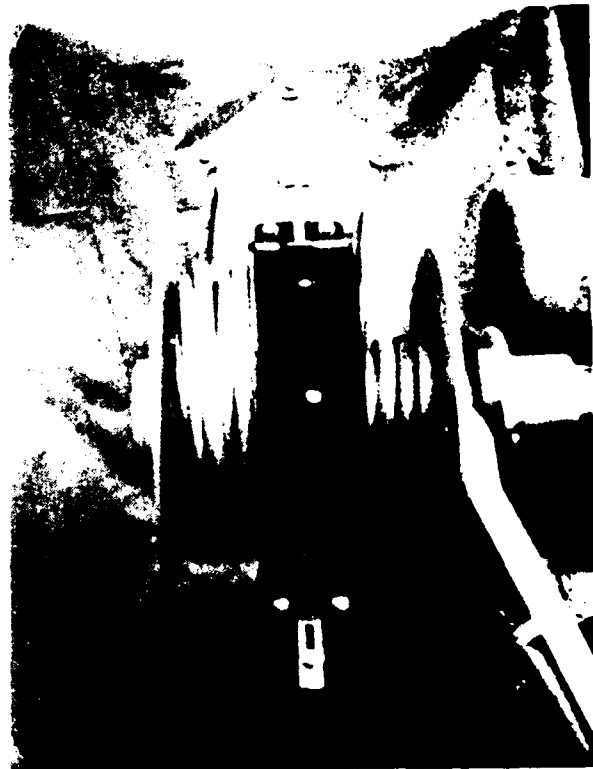

Pictured in Figure 6 is the sheave used with the cable system. The design and assembly concepts used for the winch drum are also used in the sheave. A sheave diameter of 120 cm has been found to function satisfactorily

with the fairing modules. The polyurethane nosepieces which couple one fairing to another are flexible. If the distance between the drum and sheave is over 2.5 m, the fairings deployed from the top of the drum spiral in orientation, as partially illustrated in Figure 6. This can pose a problem for the sensors mounted in the nosepieces of the fairings. To keep the approaching fairings oriented in plane with the sheave, a fairing-flipper mechanism (shown in Figure 6) was added to the sheave. Depending upon the direction of rotation, a drag-clutch will move the fairing-orientation wheel against the incoming cable and gently transform the fairings in plane with the sheave.

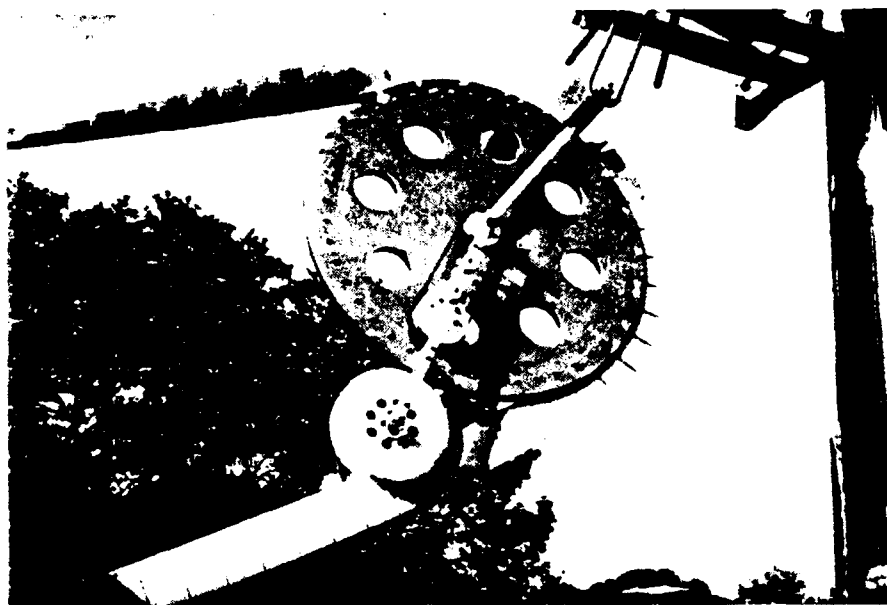

Figure 6. Shown is the sheave and fairing orientation wheel used. It is designed for use with the faired cable.

It has been unnecessary to use a fair-lead mechanism to have the faired cable properly reel and unreel from the drum. This capability has been made possible by the spacing of the plastic groove extrusion on the drum surface, the flexible nose sections, and the spacing of the winch approximately 10 m back and in line with the sheave. As seen in Figure 7, the fairing during

deployment will flex roughly 180 degrees between the winch and the sheave. During payout, if the fairing is allowed to flip to the left, it will smoothly unstack from the drum. For reeling in the cable, the fairing would be flipped to the right. In this position the fairing will smoothly track the plastic groove and stack on the drum.

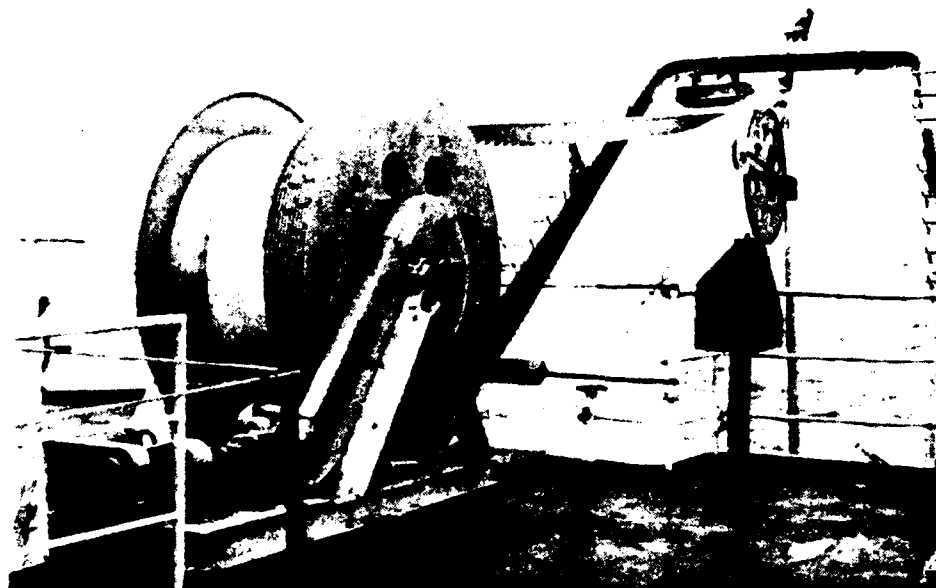

Figure 7. The DIPS winch as it was used on the NOAA vessel OCEANOGRAPHER. In this case, steel "I" beams clamped to the winch base were welded to the deck. The winch, sheave, and dead-weight have a combined weight of 2000 kg.

### Instrumentation

The three electrical conductor bundles housed in the fairings are the analog signal and power conductors between the in situ sensors and the shipboard digital encoding and recording equipment.

Part of the flexibility desired for the cable system was the ability to move sensors along the cable at sea without affecting their measure-

ment credibility and security. This feature mandates that the design incorporates a method of making secure and uncompromising connections to the conductor wires and that where along the cable the sensor was moved to, it would not affect the measurement.

The design criteria for sensor interchangeability and signal security established the need for distributing some of the sensor signal conditioning electronics in situ.

The signal conditioning amplifiers are molded into a water-tight package which is designed to fit into the tail section of modified fairing. Figure 8 shows one of the molded amplifiers with the temperature sensor being placed into the faired cable.

Signals from the in situ amplifiers are outputted to the signal wires through low impedance driver circuits. These signals can then be received by the high input impedance instrumentation amplifiers with high common mode rejection ratios (>100dB), which minimizes pickup and eliminates the effects of the signal wire resistance.

For instance, analog signals from the temperature sensor through the output of the surface instrumentation amplifiers have been measured with resolutions better than .0005°C with a bandwidth of 5 Hz. From the in situ sensor to the surface amplifier manifold, the instrumentation function is analog. The simple block diagram shown in Figure 9 shows that in the present DIPS instrumentation design there is need of a surface amplifier for every in situ amplifier. This measurement method has functioned very well but it obviously poses a limit to the number of sensors manageable on the cable. From the amplifier manifold, signals are digitally encoded with the equivalent of a 15-bit digitizer under the control of a Digital Equipment Corporation PDP-11/10 and stored on magnetic tape.



Shown in Figure 10 is the suite of surface electronics equipment that accompanies the DIPS system.

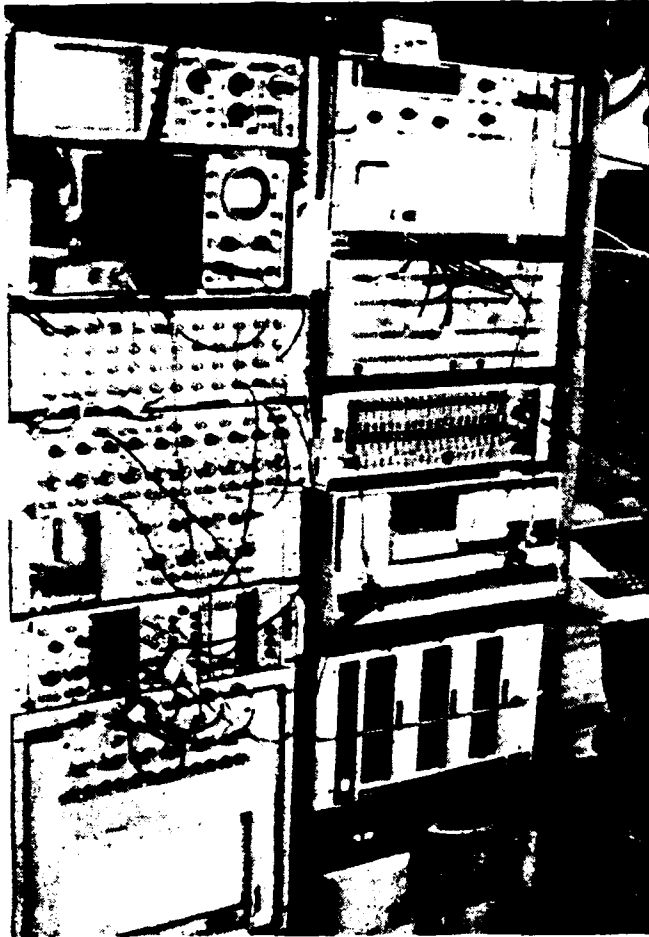

Figure 10. The bulk of the equipment shown in this Figure is for processing and recording data from DIPS. The surface amplifier manifold is seen just above the PDP-11/10 computer in the rack on the right.

### Sensors

Temperature, pressure (depth) and seawater conductivity, oxygen, and a scatterometer have been the sensors under consideration for DIPS. To date, only the first three sensors have been used in field programs.

Thermistors have been used for the temperature sensor. The series P85B10 thermoprobe manufactured by Thermometrics Inc. consists of a small

bead thermistor hermetically sealed into the tip of a shock resistant glass rod. The tip of the probe contains a 0.010 in. diameter glass coated bead, most of which is exposed to provide an extremely fast response time. The glass coating on the bead is kept very thin to provide a flat frequency response for flow applications. The unit's thermal time constant (in water) is 7 ms.

Each thermistor is molded into a polyurethane replica of the fairing nose section which can be seen in Figure 12. An enlargement of the thermistor (black bead) in the nose section is shown in Figure 11. Mounting the thermistor in the nose section provides an unobstructed exposure to the water being monitored. The thermistors are recessed in the nose sections so that they can pass over the sheave without damage.

Figure 11. An enlargement of the thermistor used for the temperature sensor. The thermistor is seen as the small black bead on the end of the glass stem.



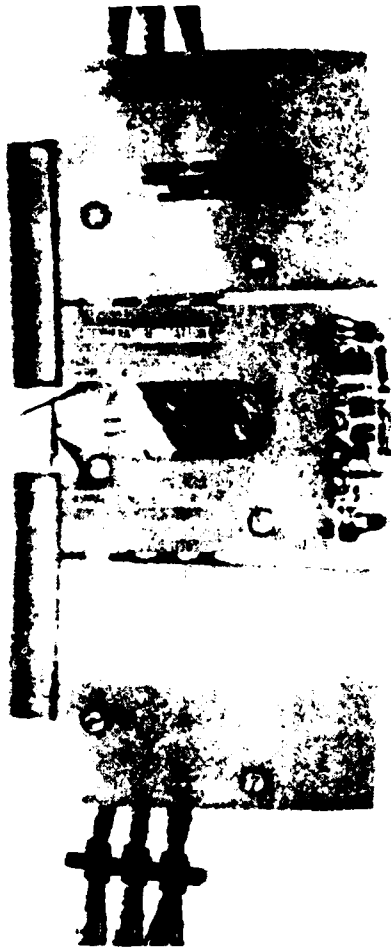

Figure 12. The thermistor for temperature sensing with its normalizing resistors is molded to fit within a segment of the fairing nosepiece. The thermistor/amplifier is calibrated as an assembly and then inserted into the faired cable as shown in the Figure.

Miniature semiconductor strain gauges (model PTQH-360-250 Kulite Semiconductor Inc), are used for measuring pressure (depth). These transducers have the equivalent size of a TO-5 transistor can and can be mounted and potted directly on the signal conditioning amplifier circuit board. A small tube is brought through the potting to an oil-filled bladder for the pressure sensing. When the amplifier/transducer is mounted on the fairing, the bladder is inside the two fairing halves. The sensitivity of this model transducer is 0.5 mV/psi. Before being put into the field, the pressure transducer modules are calibrated against a pressure gauge standard. A typical temperature structure towed profile from data acquired with DIPS cable system is shown in Figure 13.<sup>3,4,5,6,</sup>

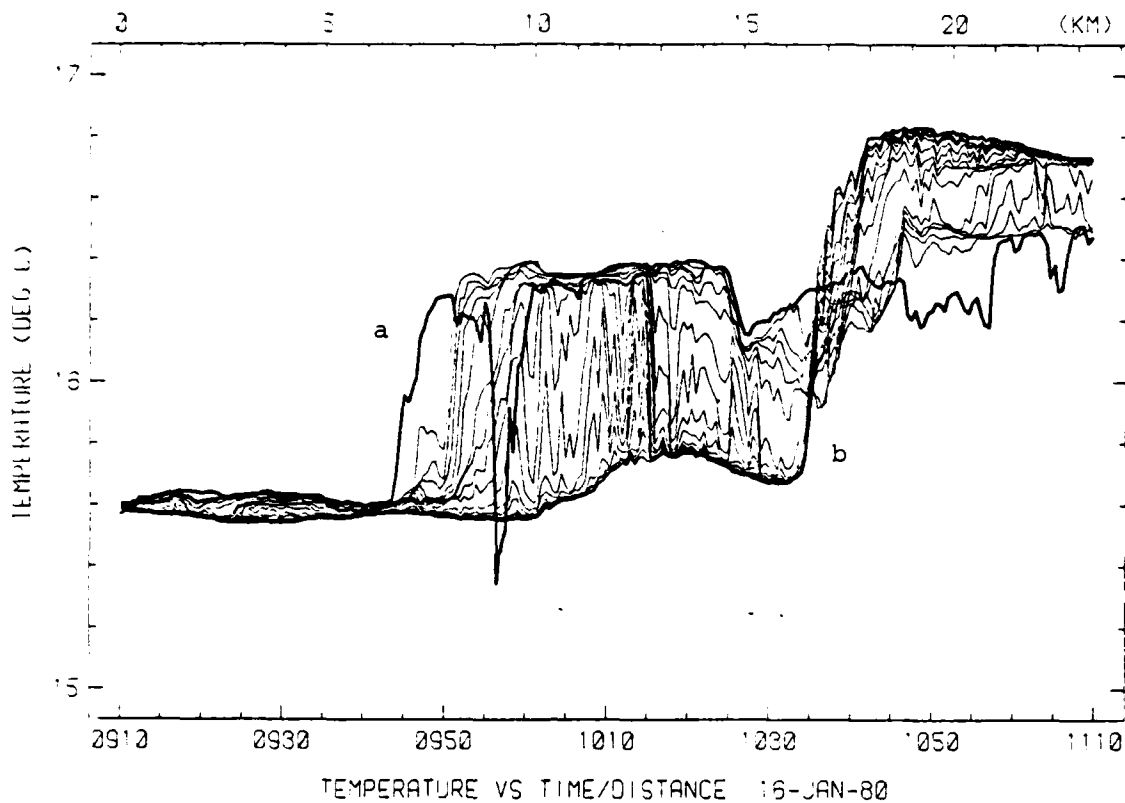

Figure 13. An example of frontal structure observed near 33.3N, 150.0W during FRONTS-80. Temperature sensors are distributed between 14 and 94 meters. Trace (a) is from the uppermost temperature sensor and trace (b) the lower most sensor.

The realization of an in situ seawater conductivity sensor has been more difficult to achieve than the temperature and pressure sensors. This is partially true because the sensor is larger, more sensitive to external influences, and requires more complex sequel conditioning circuits. In addition, the sensor and amplifier package needs to be integrated into the fairing.

#### Conductivity Cell

A four-electrode cell can be used to measure the conductivity of sea water. One of the circuit techniques for carrying out such measurements is

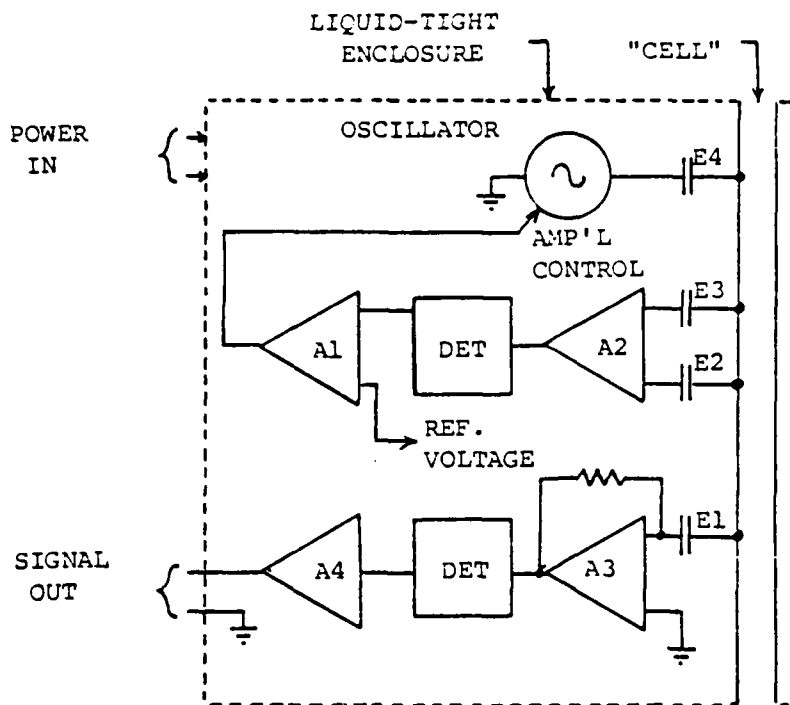

Figure 14. A block diagram of the conductivity cell and measuring circuit.

shown in Figure 14. In that circuit, operational amplifier A3 is used to convert the current received by electrode E1 into a voltage. The nature of such amplifiers is that, due to the feedback, the impedance at the amplifier's input terminal is very low so that electrode E1 is approximately at alternating current ground.

Electrode E4 is the driver electrode and voltage divider action occurs between E4 and E1 within the conducting liquid in the cell. Electrodes E3 and E2 sense voltages along the current path between E4 and E1 but do not significantly interfere with the current flow. This lack of interference is due in large measure to the very high input impedance of amplifier A2. Amplifier A2 is a differential amplifier which has an output voltage proportional to the difference between the signals from E3 and E2, respectively. This signal is detected (converted to dc) and the result is compared to a reference voltage. If the detected voltage is greater than the reference, then the amplitude of the oscillator is reduced and vice versa. This

action controls the signal applied to E4 in such a way that the signal sensed between E3 and E2 is proportional to the reference voltage. Under these conditions, the cell current between E4 and E1 is proportional to the conductance of the water sample in the space between E3 and E2.

The implementation of a conductivity measuring technique just described suffers from several limitations for in situ applications. These limitations arise, primarily, from the basic geometry of the cell itself. One source of these limitations is the existence of an exterior signal current path. Not only does current travel directly through the cell from E4 and E1, but also from E4 and E1 around the exterior of the cell. This exterior current flow causes the cell to be sensitive to the external environment, such as the steel support cable. The result of this sensitivity is that the calibration depends on the presence of external hardware and the space around the cell when it is in the calibration tank.

One way which was tried to reduce the exterior current path was to place a guard electrode between E4 and the end of the cell. If such an electrode is at ground, most of the current flowing toward that end of the cell should flow to the guard electrode rather than outside. The best guard electrode configuration which performed this task adequately was a screen completely covering the end of the cell. This was deemed physically unacceptable because the screen presented a restriction to fluid flow and a potential clogging point for debris. Furthermore, due to the small spacing between E4 and the guard, the impedance of the path was quite low, bringing about a large alternating current flow in that path. This caused the cell's sensitivity to drop by about 50 percent because about half of the signal current in E1 was no longer present.

A second limitation is the susceptibility of E1 to extraneous signal currents. This electrode can pick up not only currents from E4 but from any other source. Attempts to guard this electrode had somewhat similar results to the previously described efforts. While the guarding was fairly effective with less than a full screen over the end of the cell, again about half of the signal current was lost. The driven electrode was not as heavily loaded, but there still existed significant external signals from E1.

A third limitation arises because of the combined presence of the two previously described conditions. One cell can interfere with another. This occurs when the external signal of one cell is picked up by the current-sensing electrode of a second cell. Furthermore, if the external signal of one cell penetrates into the interior of a second cell such that it is picked up by the feedback electrodes E2 or E3, the amplitude of the oscillator for that cell will also be altered. Both of these situations have been observed and have contributed measurement errors.

A significant improvement in the cell could be obtained if: 1) there were no external current path, and 2) all of the signal current from the driven electrode could be captured by the current sense electrode. One way these conditions can be approached is through some geometrical transformations on the basic cell, as shown in Figure 15. In the configuration shown in Figure 15 (e), the driven electrode is in the center. Current flows both ways from the driven electrode toward E1 and E1'. Now, the external signal path is at least greatly reduced (though not absolutely eliminated). A very large fraction of the current travels to, and is intercepted by, E1 and E1'. Thus, almost all of the signal current contributes to the sensed currents in E1 and E1'.

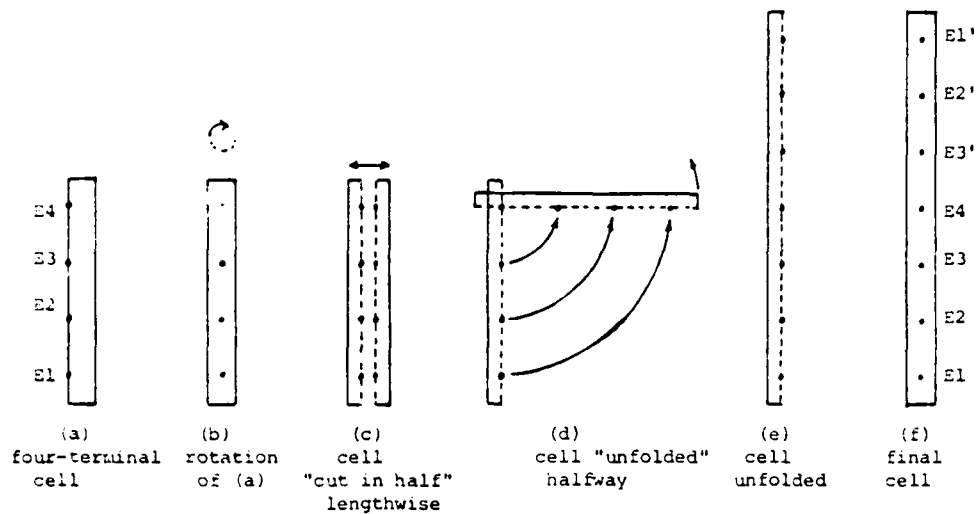

Figure 15. Conductivity cell transformation diagram

Since E1 and E1' are both current-sensing electrodes and are both at ground, they can be connected together. Either or both E2' and E3' may be redundant. This cell has been operated in two configurations: one with E2' and E3' not present, allowing one leg of the cell to provide the feedback signal to the amplitude control of the oscillator; and, in the second configuration, E2' and E3 have been eliminated, using signal differences between the two legs to control the excitation amplitudes. It would not be a good idea to connect E2 to E2' and E3 to E3' because, if slight differences in the two halves of the cell were to occur, the resulting voltage differences would cause currents to flow from E3 to or from E3' or E2 to or from E2'. In this case, these sense electrodes would then affect the current pattern in the cell and the result may not be desirable. With E2' and E3' eliminated in Figure 15 (e), the final cell configuration is left with five electrodes.

An analysis of the feedback control with respect to electrode impedances shows that feedback from E2 and E3, or E2' and E3', has reduced sensitivity

with respect to electrode impedances at E1 and E4. Cross-coupled feedback E2 to E3' or E2' to E3, does not provide as much isolation from E1 and E4 impedances.

Figure 16. Region near current-sense electrode.

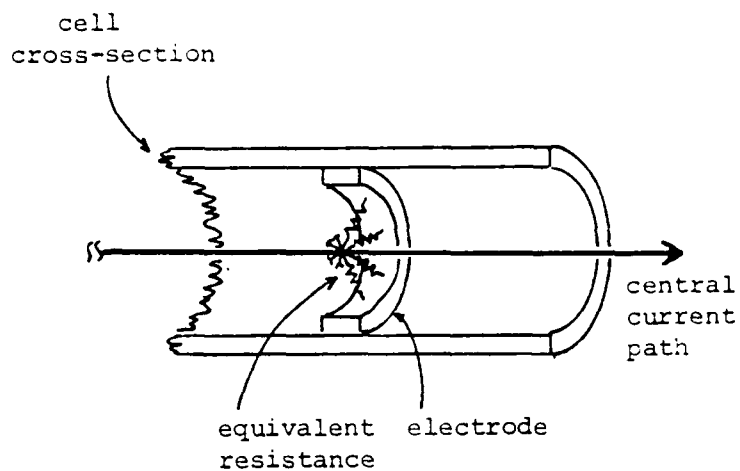

The modification described here does not reduce the sensitivity of E1 or E1' to external currents; neither is the external signal completely eliminated. The sensitivity of E1 to external signals arises from exactly the same sources as previously described for the four-electrode cell. There has been no alternation of the geometry, which improves that problem. The incomplete elimination of external currents arises from the finite impedance between the electrode E1 or E1' and the core of the cell tubing. This can, perhaps, be visualized as shown in Figure 16. There, the finite resistance between the electrode and one of the possible current flow paths is shown. The presence of a signal within an annular electrode has been shown by actual measurement.

The effects caused by the situation shown in Figure 16 can be reduced several ways. One is to make the electrode with a larger surface area. There is a practical limit, however, dictated by available space. Due to

other factors, the signal would not be eliminated if the electrode resistance were zero. This is because of the coupling capacitor between the electrode and the electronics (see Figure 14), which adds a finite impedance in series with the electrode, and because the input to the op-amp (A3 of Figure 14) is not exactly at ground. The latter two factors can be reduced, but not eliminated: by choosing the largest possible coupling capacitor, by choosing op-amp with very high open-loop gain, and by reducing the required voltage gain from the amplifier. None of these measures, however, will eliminate the external signal nor alter the sensitivity to external signals.

An analysis of the input of amplifier A3, including the effect of finite gain and bandwidth of the operational amplifier, shows the equivalent circuit of Figure 17.

Figure 17. Amplifier input equivalents.

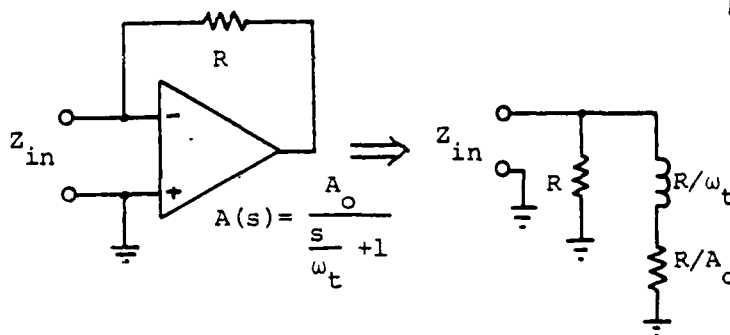

For frequencies above  $\omega_t A_o$ , which is the -3dB frequency of the amplifier, the input impedance is substantially inductive. For many operational amplifiers, this range is about 100 Hz to 1 MHz and covers the normal conductivity cell operating frequency range. As an example, at 10 kHz with an op-amp having 80 dB gain and 1 MHz unity gain frequency and using  $R = 1k\Omega$ , the apparent input circuit is  $1000\Omega$  shunting the series combination of .16 mH and  $1.1\Omega$ . This is approximately  $10\Omega$  reactive in series with  $0.1\Omega$

resistive. Attempts to lower the electrode load impedance by making the coupling capacitor as large as possible does not improve the situation.

The electrode load impedance can be reduced, however, by choosing the coupling capacitor to resonate at the operating frequency. If the coupling capacitor has adequate  $Q$ , then the input impedance will be  $R/A_0$ . However, capacitors of reasonable size will have enough effective series resistance to dominate. The minimum impedance, as seen by the electrode, will be determined by:  $R/A_0$ , by the series resistance of the coupling capacitor, and by the  $Q$  of any additional inductors used to get a more appropriate coupling capacitor size. Harmonics present in the alternating current signal will cause additional voltage since the circuit is not resonant at those frequencies.

It is not desirable to have the resonant circuit  $Q$  too high. If the  $Q$  is high, the stability of the signal frequency, input capacitance and inductance, and amplifier  $\omega t$  becomes more critical. There is also little practical gain from increasing the  $Q$  beyond the point where the electrode load impedance is less than one fifth of the electrode impedance.

Experiments have shown that guard electrodes at the end of the cell can reduce the external field, but not eliminate it. This comes about because these electrodes have the same limitation as electrodes  $E_1$  and  $E_1'$ . In balance, however, sensitivity or equivalent cell constant is reduced and the percentage change in sensitivity, when an external grounded member is introduced, is nearly the same. That is, external signal is fractionally reduced, sensitivity is also reduced, and no improvement occurs with respect to the presence of external objects.

The addition of a pair of guard electrodes outside  $E_1$  and  $E_1'$  will improve both external signal rejection and reduction of external cell signal. The guard electrode intercepts much, but not all, of the external signal

traveling toward E1 and E1'. It also intercepts some, but not all, of the signal escaping past E1 and E1'. The guard electrodes must also be capacitor-coupled so that both coupling impedance and electronic impedance prevent the guard electrode from being perfect. The capacitor can be connected to ground rather than to op-amp input which eliminates that contribution to the electrode signal. Guard screens at each end of the cell would probably be nearly 100 percent effective but are not operationally acceptable. The cell, as shown mounted in the fairing in Figure 18, is made by a local glass blower of pyrexglass. Cells made in this manner have proven to be consistent for sensor interchangeability purposes. The electrodes are composed of 90 percent platinum and 10 percent iridium wire.



Figure 18. The conductivity cell and conditioning electronics are in separate fairings. They are also calibrated together and function as a unit. Water enters the cell through scoops visible just above the top electrode and exists at the bottom.

Conductivity performance has been measured using a circuit of the type diagrammed in Figure 14, together with the electrode impedance reduction scheme described above. This circuit was used with a cell of the type previously described. Tests were made in a temperature-controlled tank with periodic samples measured on a laboratory salinometer. The tests show a useful span from 20 mmho/cm to 60 mmho/cm with good linearity. Stability and noise performance measurements will be concluded in late 1981.

Tow tank tests on a cell of the type described above (cell length approximately 0.1 m) showed a flushing time of approximately 0.5 s at a tow speed of 0.9 m/s. Flushing time was approximately the same at 0.4 m/s. These values were determined using a dye tracer.

#### Future DIPS Design Considerations

In a system design of this type there are a number of intermingling factors which have a tendency to amplify numbers and sizes of things. For instance, if more sensors are necessary, then you need more conductors, perhaps a bigger fairing, a bigger winch, more surface amplifiers and so forth. The purpose of this section of the report is to capitalize on the experience background of DIPS and to highlight some system design projections that would allow the system to be more flexibly applied in other oceanic measurement programs without incurring major system changes.

Some of the capability goals for a future DIPS measurement system are:

- In situ electronics should be adaptable to a variety of sensors without the need for measurement system modification
- Sensor location on the deployed cable should not be restricted because of the type of sensor
- Sensor relocation should be easily done
- Graceful measurement system degradation (failure of any one part of the system should allow the rest of the system to function normally)

- Sensor calibration should be able to be performed independently of the conductor cable and shipboard electronics
- Easily understood and maintainable by shipboard electronics personnel

For the shipboard data handler, the DIPS measurement system goals are:

- Accessibility of the data to computers or to display hardware.
- Should operate as a peripheral to a dedicated scientific data processing and data gathering system
- Source (sensor) and meaning of data should not be ambiguous
- System should not limit the user to a specific computer or program language
- Hardware required should be universally available to computers of different makes by purchase and not be custom design
- Software required should be easily incorporated by high-level languages
- The data system should be able to respond directly to simple requests from a keyboard entry

A measurement system that meets these goals can be a very functional and cost-effective towed vertical profiling system.

The present DIPS instrumentation system is done with the analog mode from the sensor to the surface amplifier manifold. Beyond the manifold analog, signals are digitally processed and stored. In this system the design specifications were very simple: design into the system the necessary impedance and noise isolation between the sensors, conductor cable, and surface electronic operations to make it reliable. As these design specifications were implemented for the research program that DIPS was developed for, the measurement concept has functioned very well. DIPS is, however, limited in the number of sensors (2 wires each) that the system can have without increasing the number of conductor wires, thereby amplifying the system's physical size. Roughly estimated, the maximum conductor bundle size that will

fit into the fairing clamp (770T) is three bundles of 30 twisted pairs. This number of wires (90 pairs) will accommodate close to, but be limited to, 80 sensors. To change the 90 pairs of signal wires into an apparently larger number, a form of signal multiplexing will be necessary. The choice would be to multiplex the sensor signals onto the signal wires in the analog or the digital mode. Either method would work. At this phase of design consideration, however, the one clear reason to vote against multiplexing analog signals up the cable is that if there is even the slightest shunting of the cable by water leaks, the quality of the data would be compromised. This is not true for digital signal transmissions on the cable. If a water leak occurs on the cable during the transmission of digital data, it can compromise the quality of the signal level but not the digitized value. It is better design to separate data quality from the cable parameters in situations where the cable is under constant assault from the dynamic ocean environment.

The amount of electronic hardware to address, condition, and multiplex the signals in either the analog or digital mode is about the same. Due to the applications and technology advancements in the large scale integration of digital electronics, the size and diversity of electronic functions on a single semiconductor chip makes using digital techniques more attractive.

The choice has been made to maintain the conductor bundles at the present size and use digital data encoding in situ and serial data transmissions up the cable (RS-232 with the 20-mA option). The following is an estimate of how many sensor stations can be used with the present number of conductors. Assuming a half-duplex 9600 baud rate (few computers support baud rates greater than 9600) and four 10-bit characters per data word (one sensor station), then a set of signal lines could handle 240 data words per second; with each data station set at 10 samples per second, then an optimum set of

TABLE 1

| Sample<br>—<br>Sec. | Baud Rate |         |         |
|---------------------|-----------|---------|---------|
|                     | 2400      | 4800    | 9600    |
| 5                   | 835/12    | 1680/24 | 3340/48 |
| 10                  | 420/6     | 840/12  | 1680/24 |
| 15                  | 280/3     | 560/6   | 1120/12 |
| 20                  | 210/1.5   | 420/3   | 480/6   |

Total  
Sensors  
/  
Max.  
Per  
Pair

Half-duplex

24 data stations could be supported per pair of signal wires. Ninety pairs of signal wires (reserving 20 pairs for power), and with each pair able to handle 32 sensor stations at 10 samples per second, the maximum number of sensor stations the array could have is 1680.

Table 1 is to illustrate the number of sensor stations possible, using 70 pairs of signal wires in the cable bundles at four different sample rates and three different baud rates. The table illustrates that the present cable capacity is adequate, if not excessive, when the design option for multiplexing is used. The number below the slash line in each box is the maximum number of sensor stations allowed per pair of cable wires at the stated baud rates.

It is recommended that power to the individual sensor stations on the DIPS unit be grouped eight to twenty per pair of power supply wires. This distribution of sensors over a group of power supply wires prevents the act of a catastrophic power failure from terminating the use of the cable. If a power line connection or water leak occurs on a power pair, the power loss

on the cable will affect only the six to eight units attached to it, and if the units are intermingled along the sensor array, a portion of the array will remain functional. This design feature is part of the graceful system degradation goal stated earlier.

For full-duplex data transmission, three wires are necessary: one for receiving, one for transmission, and a common. Using three wires instead of two for the half-duplex exercise just reported in Table 1 requires a recomputation of the number of data stations that can be accommodated. The number of allowable stations shown in Table 2 were computed using bit allocations for full-duplex transmission while keeping the number of signal wires available in the fairing bundle constant.

TABLE 2

| Samples<br>—<br>Sec. | Baud Rate |         |         |
|----------------------|-----------|---------|---------|
|                      | 2400      | 4800    | 9600    |
| 5                    | 960/21    | 1920/42 | 3840/80 |
| 10                   | 480/11    | 960/21  | 1920/42 |
| 15                   | 240/5     | 480/11  | 960/21  |
| 20                   | 120/2     | 240/5   | 480/11  |

Total  
Sensors  
/ Max  
Per  
3-wires

Full-duplex

Normally, full-duplex data transmission provides for a doubling of data volume over the half-duplex option. However, the restriction on the number of signal wires to 70 pairs is reflected in a muted increase in the number of data stations. As seen in Table 2, the increase in the number of data

stations is approximately 15 percent. Two considerations can be made at this point: one is to reduce the number of wire pairs (keeping the same size fairing), and the second is to review the possibility of using a smaller size fairing that is adequate to house the small number of wire pairs. The winch capacity and fairing size issue will be discussed later in the text.

#### Digital Sensor Module

An adequate signal wire capacity can be contained in the fairing size used in the DIPS system to accommodate (depending upon the sampling rate) up to several thousand digital sensor modules. The next subelement of a digital towed cable system that needs to be specified is the in situ digital sensor module. To have a totally flexible measurement system and to have some of the system goals stated earlier, it would be highly desirable to have the sensor module: digitally addressable, encode signals digitally, independently calibrated, and have adequate transmission rates.

One LSI semiconductor chip that is a most attractive candidate for use in the digital sensor module is the MCL4469 (CMOS) Addressable Asynchronous Receiver Transmitter (addressable UART) manufactured by Motorola. This chip will receive one or two 11-bit words in a serial stream. The first incoming word contains the address and when the address decode matches the MCL4469 address, it is enabled to transmit two 8-bit data words in full duplex at 4800 baud. Control and data lines from this chip are then coupled to an analog-to-digital (A/D) converter which samples outputs from an analog sensor.

A basic consideration in the design of a digital sensor module depends strongly on the availability of suitable digitizers or analog-to-digital converters (A/Ds). Using a 30°C temperature span measurement as the benchmark, a 10-bit digitizer will provide a resolution of approximately 30 m°C; increasing the digitizer to 12-bits gives about 7.5 m°C while 14 gives about

2 m°C; going to 16 bits would give a comfortable 1 m°C.

The resolve of this requirement is balanced by the circuit power limitations and the digitizer conversion speed requirements. Power demand needs to be minimized to prevent excessive voltage drops in the power pairs in the cable bundle. Conversion speed affects the maximum sample rate for any group of sensors on a single data line. For instance, at a 4800 baud data rate, a 4 ms conversion time will add approximately 50 percent to the time required to sample any sensor. The conversion design requirement eliminates the integrating type of digitizers for which 30 ms is a fast conversion. Power minimization strongly points toward complementary metal oxide silicon (CMOS) circuits. Either of these decisions may change as technology changes, but they appear to be good choices for the near term. A strong candidate for the digitizer function is the National Semiconductor ADC1210. This device is a 12-bit digitizer using the successive approximation technique which allows conversions in 100  $\mu$ s. It is packaged in a 24-pin, dual-in-line package and requires a 4 mA at  $\pm 5$  to  $\pm 15$  volts. It needs an external clock (which can be obtained from the UART) and an external reference (which would be needed by the sensor circuit anyway). Except for the fewer than desirable number of bits, this device will fit the system requirements quite well.

The lack of adequate numbers of digitizer bits can be compensated for by using an offset voltage which keeps the signal within the digitizer span even though the signal may have a range appreciably larger than the digitizer span. Such an offset voltage can be generated by a digital-to-analog converter (DAC); Figure 19 indicates the basic concept. Using this scheme, a signal with a 5 V range could be accommodated by a 2 V span digitizer. If the DAC has 3 output steps spaced about 2 V apart, a 6 V range could actually be accommodated.

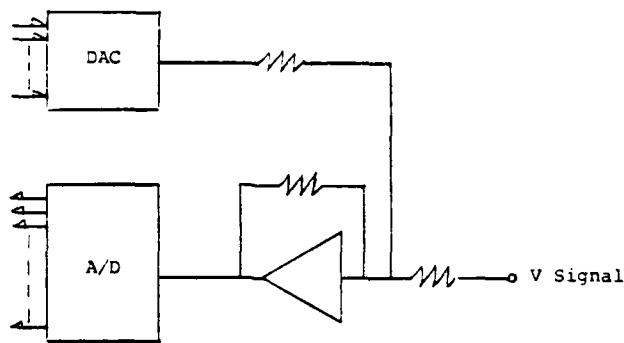

Figure 19. DAC Controlled digitizer range expansion

Note that this process is the same as increasing the number of digitizer bits. However, the DAC voltage step span may be chosen to be less than the A/D span. The major difficulty with this scheme is finding a DAC which has the required stability, linearity, etc. To add an equivalent 2 bits, a 2-bit DAC would be needed, but its specifications would have to be comparable to a 14-bit DAC. There are DACs made by several manufacturers which meet the accuracy requirements.

If a DAC-driven offset is used for resolution expansion, a method for determining the amount of offset is needed. The need for offset could be determined by the system controller and sent as part of a command word to the UART in each module. This choice simplifies the sensor module but places additional burdens on the system controller. Such a burden may prove unreasonable, however, when system speed requirements are taken into account. If the offset requirement is determined within the sensor module, then additional hardware is needed. This function could be easily carried out by testing the A/D output for near maximum or near minimum values and incrementing or decrementing the DAC control number. This scheme would result in an overlap of ranges but the decoding of the resulting data should present no difficulty.

This choice could also allow elimination of the command word transmission to the sensor module UART, saving 25 percent in data transmission time and allowing more modules on each transmission circuit. Figure 20 shows the basic block diagram embodying the concepts described in this section.

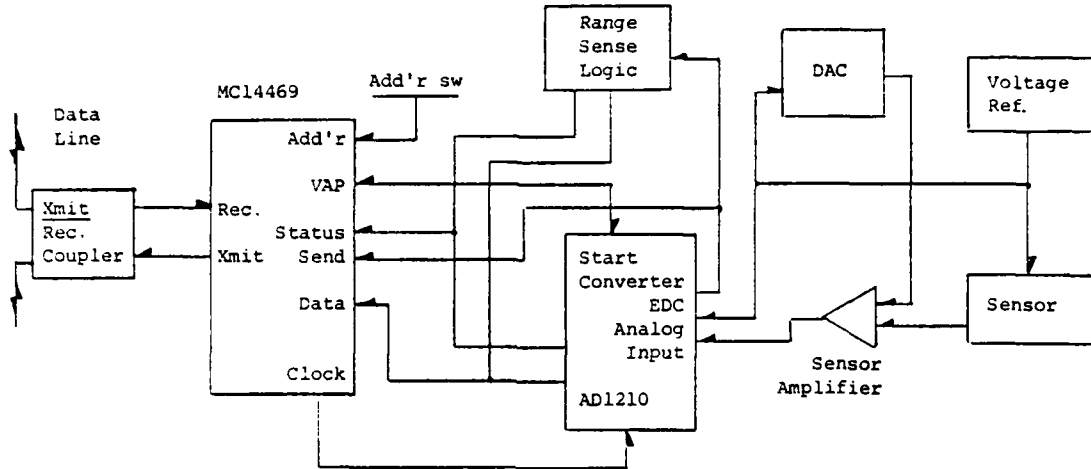

Figure 20. Sensor module block diagram.

Probable performance of a module utilizing the preceding concepts can be estimated. At 4800 baud, the UART will require 2.3 ms to receive its address. Approximately .1 ms is required to digitize the analog value. The transmission of two 8-bit-data words requires 4.6 ms, for a total of 7.0 ms. This time period will allow up to 14 stations to respond on a single communications link.

The range sense logic can consist of a pair of 4-bit magnitude comparators which are connected to the high 4 bits of the A/D output and the "end-of-conversion" signal from the A/D. These comparators would increment the DAC input when the high 4 bits are all zeros and decrement the DAC input when the high 4 bits are all ones after the conversion is complete. This would step

the offset for the next measurement whenever the current measurement is beyond a 12.5 to 87.5 percent of full scale window of the A/D. Thus, one DAC bit would represent less than A/D full scale. If one DAC bit represents 75 percent of the A/D full scale (maximum using the chosen window limits), then 4 DAC bits will represent an equivalent 12 times range expansion and the system will be slightly better than 15 bits equivalent for a resolution between 1 m°C and 2 m°C. The chosen window limits seem reasonable since the 12.5 percent at the top and bottom of the A/D range represent about 320 m°C. If being towed at 15 knots, a horizontal gradient exceeding 40 m°C/m would be required to over-range or under-range the A/D from within the window at 10 samples per second. Such a gradient approaches an order of magnitude larger than observed temperature gradients.

Considering the sample rate, (1 sample in 7.0 ms), range (30°C), and resolution (1 m°C to 2 m°C), it would appear that the proposed module design could meet the major requirements and be suitably integrated into the entire system.

This combination of chips to realize a digital function-module is the most efficient use of multifunction devices. However, there is an adequate inventory of LSI semiconductor devices with which most any function can be implemented. When the MCl4469 chip and associated components are potted for underwater use, they form a small enough package that it could be mated with a fairing smaller than the one used on DIPS.

Signal outputs from each in situ digital module would be inputted at the surface into a serial-to-parallel UART. This array of topside electronics would form the cable electronics interface to the user's computer system.

Sixteen bit parallel outputs from each digital module would be available, as they are addressed, to a computer for processing and storage.

The full-duplex operation of the in situ data station requires three signal wires. However, on these three wires there can be a total of 20 data stations which function at 4800 baud and 10 samples per second. This grouping of data stations with the signal wires constitutes a loop. In the DIPS fairing there is room for signal wires for 46 such loops, each of which terminates at an interface box at the winch. It is advantageous to provide in this interface the ability to address and buffer data from each of the data stations to eliminate this task from the duty of the main process computer. At the surface end of each loop there is a UART which functions with an address generator or cable controller. Once the addresses of the data stations that are to be monitored are selected through the main computer and shifted to the interface box, there is no need for addressing interaction with the data stations. This feature would allow the computer, after initializing the address generator, to dedicate itself to data recording. Some additional considerations of the cable controller are:

- . Since the full-duplex service interval on any one loop is 5 ms and 5 loops (assume 100 sensors and 20 sensors per loop) must be serviced, 1 ms can be allocated for the service of each station by the controller (service is selection of station address and control information, if any, and later, recovering data).
- . A microprocessor can be used for the controller function. If 25 instructions are used to service any module, then  $1 \text{ ms}/25 = 40 \text{ } \mu\text{s}$  per instruction could be allowed. This would appear to be within the capability of many microprocessors.
- . Data output from controller needs contain only half the number of bits as loop servicing since addresses need not be included with the data. Since there will be 100 data blocks to output, the minimum data rate would be  $4800 (1/2) \times 20 = 48,000$  baud.
- . Since most microprocessors probably could not handle conventional data output while controlling the 5 data loops, data output not requiring the controller's attention will be needed. A possible scheme is shown in Figure 21. A possible operations protocol:

1. Load desired module addresses into controller
  - (a) May include loop number with each address
  - (b) May require controller to search its loops to find which loop contains desired module. This would also verify loop operation
2. Controller makes a table of addresses for each loop
3. Order of output data will be returned by controller
4. Load sample rate into controller
5. Give "start" command
6. Controller loads first address in each loop
7. Controller gets data from each loop while doing so, it also loads next address.
8. Controller places data, in order, in output FIFO (see Fig. 21)
9. If not last address, goes back to 7. If last address, goes back to 6.
10. Continues until "stop" command

Figure 21. A proposed system configuration for the deckside controller for use with the in situ digital sensor modules.

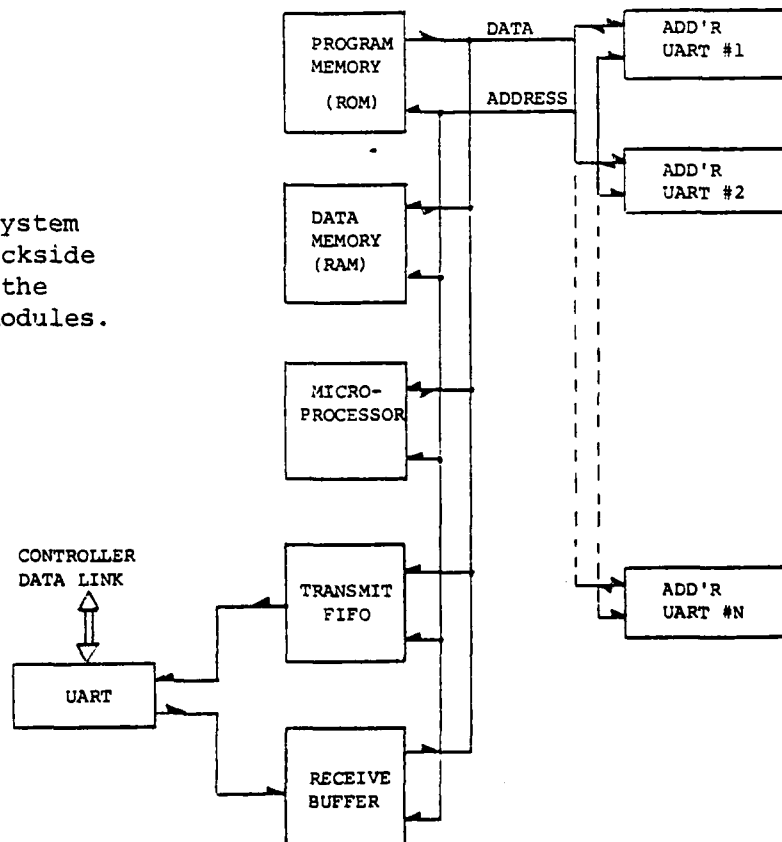

The controller may be made an integral component of the winch. It needs only be supplied with power (the same power as used for cable-mounted modules which has to go to the winch, anyway) and a command cable linking to the user's computer. Data transfer between the cable interface controller and the processing computer is more sensibly done in parallel. Allowing for cable data rates at 4800 baud, 1000 sensor data stations, and 10 per second sampling, the 16-bit data READ events from the controller would be about 10 thousand per second. This transfer rate is well within the capacity of a number of the larger capability microprocessors and minicomputers. It is difficult to specify further the processor requirements without a more complete forecast on the number of sensor stations and the extent of the required data processing and recording.

#### Winch Capacity

The Fathom Oceanology Ltd. fairing system (model 770T) has been the element around which the mechanical assembly of the towed electrical cable is built. In the limited range of application of the fairing, the use experience has all been good. However, there is no evidence that a linear projection can be made, based upon this experience, that a lengthened cable with different electrical bundles would work as well. The same can be said of reducing the fairing dimensions. The preliminary results of this report indicate that by using multiplexing on the cable, moderate data transmission rates, and several hundred sensors that the number of signal wires could be significantly reduced which exposes the consideration of using a smaller fairing. There are immediate advantages to the smaller fairing: more cable length for a particular winch drum size, lower drag, ease of handling, and it is less expensive. The net sum of these advantages would make it worth getting an evaluation on the hydrodynamic features for the smaller candidate fairings.

A fairing with a 10-cm length is best used with a drum diameter minimum of 110 cm, to prevent stress on the junction between the nose section and the sides of joined fairings. With the drum diameter fixed, winch drum width can be easily projected for different fairing widths, as shown in Figure 22. If the DIPS winch construction scheme is used, then the overall dimensions of a winch for a longer cable can be estimated. The winch length and height can remain fixed at 3 m and 2.3 m, respectively. The width dimension would be a function of the maximum cable length and fairing width. To find the overall width of the winch, add 0.5 m to the drum width taken from the graph in Figure 22 for the particular size of fairing to be used.

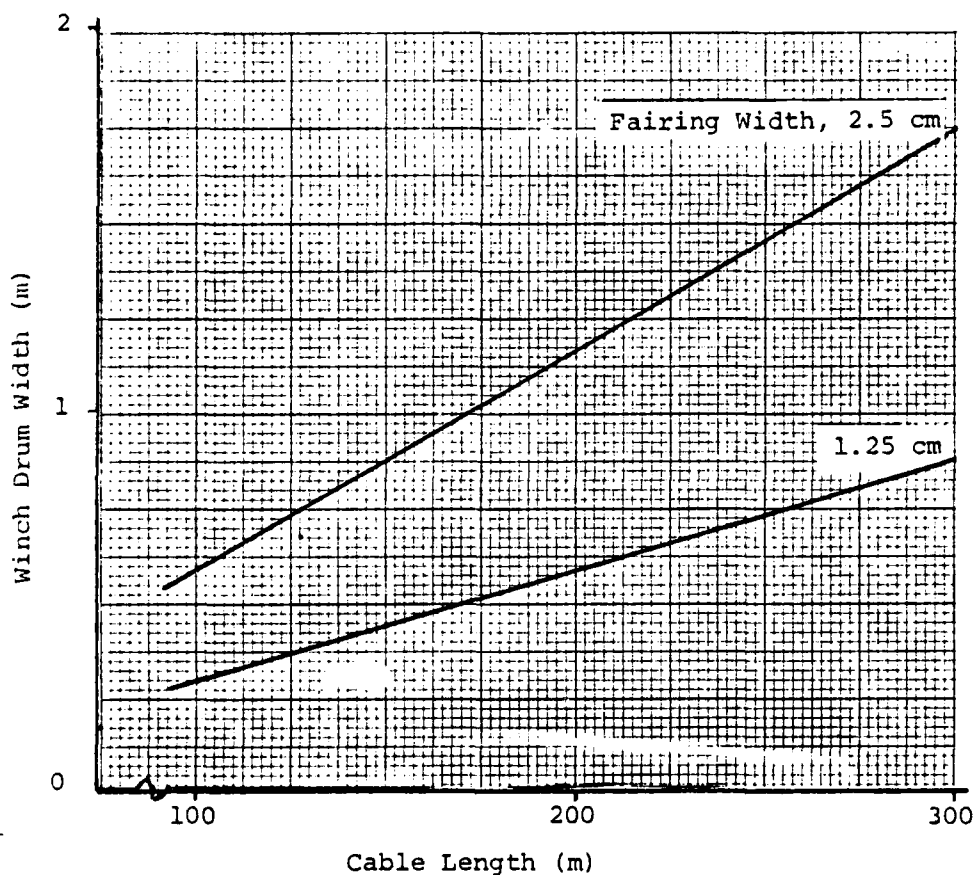

Figure 22. With this graph estimates can be made of the drum size and capacity for specific fairings. The drum diameter is 110 cm.

Another design option that should be considered has the conductor cable manufactured in a different way. There would be two distinct segments to the cable. The lower segment would appear and be assembled in the same fashion as the DIPS cable and all of the sensors would have to be mounted on it. This segment would be detachable from the second segment of steel-armored multiconductor (<10) which couples to the winch drum. There are two main advantages to this concept: the instrumented section can be more easily replaced by a spare unit or another section instrumented in a different way, and the wire segment on the drum can be longer to place the instrumented section to deeper depths. This design would require the equivalent of the surface loop termination electronics to be placed in situ at the junction of the two cables. The electronic terminal would be necessary to provide the data transmission transition from the multiloops on the faired cable to a cable type (perhaps fiber optic) that can handle a higher speed data stream.

Shown in Figure 23 is a profile drawing of an electric swivel that can be adapted to care for the mechanical torque adjustments necessary between the faired and armored cable. The profile drawing illustrates how two commercial armor cable quips can be incorporated into a swivel to perform the strain transfer function. In the case of conventional or fiber optics cable, the bell housing on the swivel can be used to house the necessary in situ electronics.

#### In Situ Signal Cable and Electronic Module Connections

Casting the underwater electronics and providing isolated electrical feed-throughs, that are compatible with the small spaces and signal wires, are an integral part of the instrumentation cable electrical security. For instance, if the cable uses 1000 sensors and there are three signal, two power, and two transducer wires per digital module, then there is a potential of 7000

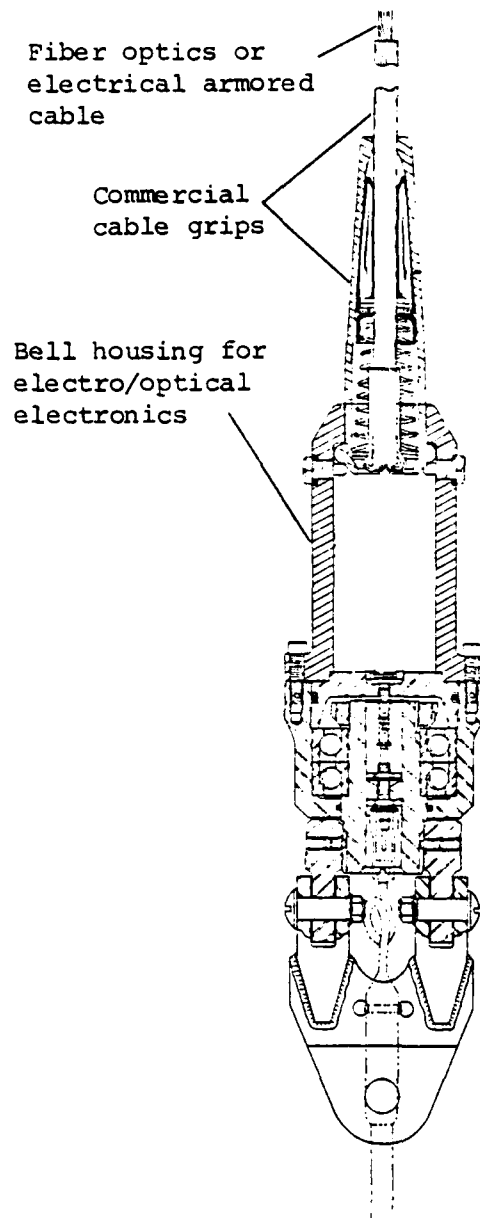

Figure 23.

electrical shorts. In the DIPS program two water seal connections have evolved. One is signal wire to signal wire and the second is signal wire to casted electronic circuit boards. The signal wires have a Tefzel<sup>®</sup> coating which offers a very abrasion-resistant surface, but one that is difficult to find a bonding agent for. In addition, the fairing compartment, where connections to the signal wires can be made, is space limited. These two conditions, plus

the need for making expedient connections between sensors and the signal wires at sea, required the development of a reliable splice technique.

Figure 24 shows the miniature splice developed for DIPS. The splice incorporates a meltable tubing of two diameters and two very small O-rings within a single clear shrink tube. The O-ring is a standard part (Minnesota Rubber 8001) and the shrink tubing and clear melt tubing are AMP Special Industry Products. The splice relies on the O-ring for seal to the Tefzel<sup>®</sup> while utilizing the melt material for void-fill and self-forming O-ring position seats. These splices have been very reliable in the field.

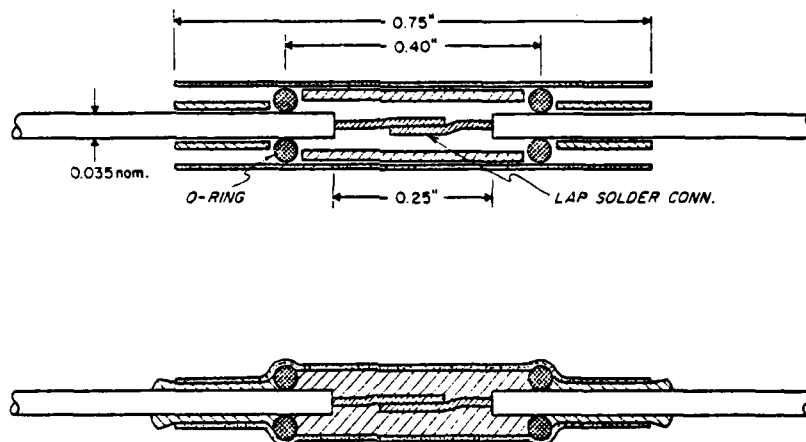

Figure 24. This illustration shows the before and after phase of a thermo shrink splice developed for the small diameter signal-wire connections in DIPS.

Of the hundreds of splices in the cable bundles used for the past 3 years, there have been few failures. These splices have also been exposed to 1000 psi of pressure in the laboratory for sustained periods and they have maintained isolation resistance above 100 megohms.

The second type of connection is from the electronic circuits cast in an epoxy resin to a signal wire. Again, miniature O-rings provide the water-tight seal between the rigid casting and the pliable wire covering.

A socket connector (Samtec SS-120-G-1A) is soldered to the printed circuit board. This connector was selected because it is made to accept a pin equivalent to a number 24 tinned solid copper wire. When the circuit board is cast in the epoxy resin, a dummy pin is placed in the socket so that when the resin hardens and the pin is removed there is a recessed hole 0.1 inch in diameter down to the socket connector. Figure 25 shows how a complete connection would appear. The O-rings rest directly on the wire insulation and the solid copper wire inserts directly into the connector. A small section of shrink tubing is added to prevent abrasion to the insulated wire. These connections are space-efficient and have proven to be easily done in the field.

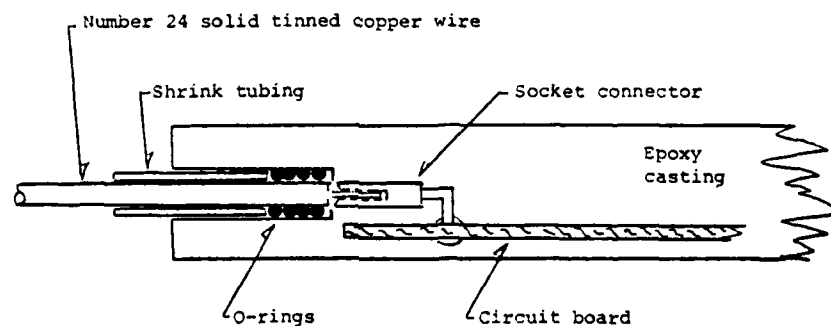

Figure 25. Illustration of how the signal wire to cast electronic circuit board connection can be made.

## Conclusion

There are three major components to the distributed instrumentation profiling system (DIPS): the winch, faired cable assembly, and the instrumentation system. In review, the winch design concept and the faired cable assembly both appear to have the capacity for expansion without major redesign to accommodate a cable 300 m long. The cable assembly technique is based upon using a commercial cable fairing component that offers a reasonable degree of latitude in independently selecting and incorporating the instrumentation and mechanical support elements of the cable. This flexibility in design should be retained.

Presently, DIPS has a measurement capability to monitor thirty temperature, four pressure, and six seawater conductivity sensors which are integrated with a 165 m faired cable with the capability of being towed at 608 knots. The in situ portion of the towed cable's measurement system is analog while the surface data processing is done in a digital mode. In its current configuration, the number of sensors on the analog measurement system cannot be expanded because of the limited number of signal wires that can be contained in the fairing modules without having to expand the winch and fairing sizes disproportionately. However, by replacing the in situ analog measurement system by a multiplexed digital measurement system, the present winch and faired cable designs offer significant sensor expansion possibilities.

Some features of the digital measurement system are:

- 15-bit equivalent digital encoding of the sensor output signal
- Full-duplex serial data transmission
- Sensors can be calibrated independent of the cable parameters
- Either digital or analog sensors can be accommodated
- Each sensor can be uniquely addressed

The fairing assembly can hold 180 signal and power conductors which, depending upon the sensor data sampling rate and data transmission baud rate, can support different numbers of sensor stations along the cable. Table 2 is reproduced here to illustrate the tradeoff between these three parameters.

TABLE 2

| Samples<br>—<br>Sec. | Baud Rate |         |         |
|----------------------|-----------|---------|---------|
|                      | 2400      | 4800    | 9600    |
| 5                    | 960/21    | 1920/42 | 3840/80 |
| 10                   | 480/11    | 960/21  | 1920/42 |
| 15                   | 240/5     | 480/11  | 960/21  |
| 20                   | 120/2     | 240/5   | 480/11  |

|   |
|---|
| Total<br>Sensors<br>/ Max<br>Per<br>3-wires |
|---|

Full-duplex

Very efficient packaging of digital circuit functions for 4800 baud data transmission rates makes the implementation of the parameters of that column of Table 2 more attractive.

Sensors presently available for the towed cable are:

- temperature
- pressure (depth)
- seawater conductivity

Sensors that have not found service on the cable but appear adaptable are:

- scatterometer
- oxygen
- fluorometer

References:

1. Mobley, F. F. et al., "A New Thermistor Chain for Underwater Temperature Measurement," Ocean 76 Conference, Washington D.C., September 1976.
2. Sippican Corporation, Marion, Massachusetts (Restricted Report), "Feasibility Study for a Towed Thermistor Chain."
3. T. J. Spoering, "Towed Observations of Internal Waves in the Upper Ocean," M.S. Thesis, Oregon State University, Reference Report 79-10, July 1979, 120 pp.
4. T. J. Spoeling, et al., "Towed Thermistor Chain Observations During MILE," Data Report 74, Reference 79-11, Oregon State University, July 1979.
5. R. J. Baumann, et al., "Towed Thermistor Chain Observations in JASIN," Data Report 80, Reference 80-14, Oregon State University, July 1980.
6. C. A. Paulson, et al., "Towed Thermistor Chain Observations in FRONTS-80," Data Report 85, Reference 80-18, Oregon State University, October 1980.

**END**

**FILMED**

**2-85**

**DTIC**