

MICROCOPY RESOLUTION TEST CHART  
NATIONAL BUREAU OF STANDARDS-1963-A

6

AD-A150 160

# SUPPLEMENT #2

## DESIGN MEMORANDUM 1 GENERAL DESIGN

### COOPER RIVER REDIVERSION PROJECT LAKE MOULTRIE & SANTEE RIVER SOUTH CAROLINA

Approved for Public Release: Distribution Unlimited.

## REQUIREMENTS FOR PROTECTION OF BUSHY PARK RESERVOIR



DTIC  
ELECTE  
JAN 28 1986  
S  
E

DTIC FILE COPY

U.S. ARMY ENGINEER DISTRICT, CHARLESTON  
CORPS OF ENGINEERS  
Charleston, South Carolina

FEBRUARY 1976

COPY NO. 135

85 01 15 081

SADEN-GK (4 Aug 76) 1st Ind

SUBJECT: Cooper River Rediversion Project, Lake Moultrie and Santee River, South Carolina, Appendix A to Supplement No. 2 to General Design Memorandum - Bushy Park Water Supply Tests

DA, South Atlantic Division, Corps of Engineers, 510 Title Building, 30 Pryor Street, S. W., Atlanta, Georgia 30303 14 December 1976

TO: District Engineer, Charleston ATTN: SACEN-GF

Appendix A has been added to Supplement No. 2 to GDM.

FOR THE DIVISION ENGINEER:

3 Incl  
wd 11 cys ea

*B.L. Kittle*  
for WILLIAM N. McCORMICK, JR.  
Chief, Engineering Division

Copy furnished:  
HQDA (DAEN-CWE-B)  
w/10 cy incl 1

<b>Accession For</b>	
NTIS GRA&I	<input checked="" type="checkbox"/>
DTIC TAB	<input type="checkbox"/>
Unannounced	<input type="checkbox"/>
Justification	
By _____	
Distribution/	
Availability Codes	
Dist	Avail and/or Special
A-1	





**DEPARTMENT OF THE ARMY**  
CHARLESTON DISTRICT, CORPS OF ENGINEERS  
P O BOX 919  
CHARLESTON, S.C. 29402

SACEN-GF

4 August 1976

**SUBJECT:** Cooper River Rediversion Project, Lake Moultrie and Santee River, South Carolina, Appendix A to Supplement No. 2 to General Design Memorandum - Bushy Park Water Supply Tests

Division Engineer, South Atlantic  
ATTN: SADPD-P

1. Transmitted are 23 copies of the subject Appendix A. The information contained in the body of the appendix was developed for the Charleston District by the Waterways Experiment Station in Vicksburg, Mississippi.
2. Also transmitted are 23 copies of the following items for revision of the basic Supplement No. 2 report.
  - (a) Cover and back sheets for binding Supplement No. 2 with inclosed Appendix A.
  - (b) Revised Table of Contents page.

3 Incl.  
as

HARRY S. WILSON, JR.  
Colonel, Corps of Engineers  
District Engineer



## ABSTRACT

The Charleston Harbor model reproduced the Ashley, Cooper, and Wando Rivers, and a portion of the Atlantic Ocean. The model was of fixed-bed construction and was equipped with all the necessary appurtenances for accurate reproduction and measurement of tides, tidal currents, salinity intrusion, and other significant phenomena of the prototype.

Construction of the Santee-Cooper power project in 1940-1942 included diversion of flow from the Santee River into the Cooper River watershed. Average freshwater flow into Cooper River was increased from 72 cfs to 15,000 cfs, and maintenance dredging in Charleston rapidly increased from about 180,000 cu yd per year up to 10,000,000 cu yd today. Prior studies led to the conclusion that rediversion of a major portion of the Santee River flow would result in a substantial reduction in maintenance dredging in Charleston Harbor. The amount of Santee River flow to leave diverted into Cooper River became a critical value with respect to power generation at Pinopolis, water quality in Charleston Harbor, and the prevention of saltwater intrusion into the Back River Reservoir constructed to supply freshwater for the Bushy Park industrial area and the City of Charleston. The results of previous studies indicated that a weekly average flow of 3000 cfs would be satisfactory with respect to reduced maintenance dredging. The power requirements could also be satisfactorily met with a minimum weekly average flow of 3000 cfs. A detailed study involving various weekly schedules for release of the 3000 cfs on conditions in the upper reaches of Cooper River and the Bushy Park Reservoir was considered necessary.

Hydraulic and salinity tests were made for six weekly release schedules from the Pinopolis power plant. The first involved the continuous release of the existing weekly average freshwater discharge at the Pinopolis power generating station of 15,600 cfs, which is referred to as Schedule A. Schedules B, C, and D all involved release of the 3000-cfs weekly average flow; however, the respective daily flows were different. Schedule B had one day of 1325 cfs and six days of 3279 cfs; Schedule C had three days of zero flow and four days of 5250 cfs; and Schedule D had three days of 1200 cfs and four days of 4350 cfs. Schedule E reproduced a weekly average flow at Pinopolis of 3500 cfs, with 69 hours of zero flow, 3 hours of 28,500 cfs, and four days of 5250 cfs. Schedule BM also reproduced a weekly average flow at Pinopolis of 3500 cfs, but this schedule had one day of 1325 cfs and six days of 3860 cfs.

The results of the six tests indicated that, due to rediversion, tide levels in the upper Cooper River, Back River Reservoir, and the East Branch of the Cooper River were lowered by amounts between about 0.3 ft and 2.0 ft. Tides at stations in lower Cooper River (below mile 20), the Wando River, and the Ashley River were relatively unchanged. Surface and bottom ebb predominance was decreased drastically in the upper reaches of Cooper River, and was more nearly balanced throughout the length of Cooper River for rediversion conditions than for existing conditions. For existing conditions, the upstream limit of saltwater intrusion (100 ppm) was about Cooper River mile 25. For rediversion conditions, the upstream limit of saltwater intrusion was about mile 39 for Schedules B and D, mile 40.5 for Schedule C, and mile 36 for Schedules E and BM. The degree of salinity stratification was significantly reduced throughout the system for rediversion conditions.

## PREFACE

This report presents the results of a model study requested by the U. S. Army Engineer District, Charleston, South Carolina. The study was performed during the period November 1973 to August 1974 in the existing Charleston Harbor model in the Hydraulics Laboratory, U. S. Army Engineer Waterways Experiment Station (WES), Vicksburg, Mississippi, under the direction of Mr. H. B. Simmons, Chief, Hydraulics Laboratory; Mr. F. A. Herrmann, Jr., Assistant Chief, Hydraulics Laboratory; Mr. R. A. Sager, Chief, Estuaries Division; Mr. W. H. Bobb, Chief, Interior Channel Branch; Mr. H. A. Benson, Project Engineer; and Mr. H. R. Smith, Senior Technician. Technical help was provided by Messrs. C. R. Herrington, J. Cessna, J. T. Cartwright, D. M. Stewart, and E. S. Jefferson. This report was prepared by Mr. Benson with the assistance of Messrs. Bobb, Herrmann, Sager, and Smith.

Director of the WES during the performance of this study was COL G. H. Hilt, CE. Technical Director was Mr. F. R. Brown.

CONTENTS

	<u>Page</u>
PREFACE . . . . .	1
CONVERSION FACTORS, U. S. CUSTOMARY TO METRIC (SI) UNITS OF MEASUREMENT. . . . .	3
PART I: INTRODUCTION . . . . .	5
The Prototype . . . . .	5
Purpose of Model Study. . . . .	6
PART II: THE MODEL . . . . .	7
Description . . . . .	7
Model Appurtenances . . . . .	7
PART III: TESTS AND RESULTS. . . . .	14
PART IV: CONCLUSIONS . . . . .	25
PLATES 1-94	
TABLES 1-48	

SADEN-GK (6 Feb 76) 1st Ind

SUBJECT: Cooper River Rediversion Project, Lake Moultrie and Santee River, South Carolina, Supplement No. 2 to General Design Memorandum - Requirements for Protection of Bushy Park Reservoir

DA, South Atlantic Division, Corps of Engineers, 510 Title Building, 30 Pryor Street, S. W., Atlanta, Georgia 30303 13 April 1976

TO: HQDA (DAEN-CWE-B)

Supplement No. 2 to GDM is recommended for approval subject to the following comments:

- a. Pages 2 and 3, paragraphs 6 and 7. Since it is probable that hurricane surges would enter the Bushy Park Reservoir with or without reduced flows, we should not guarantee protection of the reservoir under hurricane conditions.
- b. Page 3, second line from bottom. The mileage figures 32.6 and 38.5 should be verified since it is our understanding that mileage distances vary on some project maps, i.e., one statement in hand indicates that "During this 10 day period, the EPA found the maximum penetration of the salt water wedge occurred at mile 28.4." Another refers to mile 33.2 and states "According to EPA studies, this is the maximum intrusion to be expected."
- c. Page 6, paragraph 12. The District has been given authority to conduct further study of monitor system requirements and provisions needed to assure protection of the Bushy Park Reservoir against salinity intrusion. This report gives the results of the study for Bushy Park and recommends that corrective action be approved.
- d. Page 1, last line. Spelling of "complex" should be corrected.
- e. Page 3, second line from bottom. Spelling of "Bushy" should be corrected.
- f. Page 4, line 7. Spelling of "Bushy" should be corrected.

FOR THE DIVISION ENGINEER:

2 Incl  
wd 10 cys ea

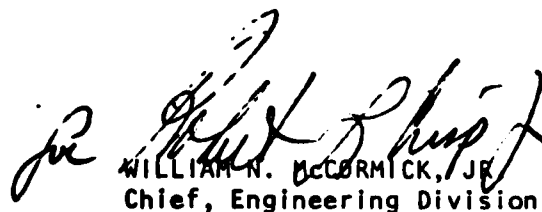
  
WILLIAM N. MCCORMICK, JR.  
Chief, Engineering Division

Copy Furnished:  
District Engineer, Charleston  
ATTN: SANGE

3

DAEN-CWE-B (SANGE, 6 Feb 76) 2d Ind

SUBJECT: Cooper River Rediversion Project, Lake Moultrie and Santee River, South Carolina, Supplement No. 2 to General Design Memorandum - Requirements for Protection of Bushy Park Reservoir

DA, Office of the Chief of Engineers, Washington, D.C. 20314 21 June 1976

TO: Division Engineer, South Atlantic, ATTN: SADEN-GK

1. The subject Supplement is approved, subject to the comments of the Division Engineer in the 1st Indorsement, and to the comments in the following paragraphs.

2. Paragraph 8. The application of a mathematical model appears feasible for computing the salinity migration under various combinations of flow and tidal conditions for the study project. In view of the potential cost savings in terms of selecting the number and location of monitoring stations, and the provision of better information for formulating the "Operations Manual" of project operation, the possibility of application of a mathematical model should be explored.

3. Paragraph 9. An investigation should be made of the possibility of using slotted bulkheads for diversion through the skeleton bay at the Pinopolis plant to obtain emergency flows.

a. Model and prototype tests at the Snake River projects in Washington have shown that flow control through skeleton bays by operation of the intake gates is not practicable at these projects. Instead, slotted bulkheads (intake diffusers) were used in both the skeleton bays and operating units to divert water to reduce spillage. Only minor modification to the skeleton bays was required. The bulkheads when used with the operating units maintained near maximum discharge with more than a 90 percent reduction in unit output. Most of the head is dissipated across the slotted bulkheads.

b. For the above described system to be applied, emergency closure provisions are necessary in case of bulkhead failure. This was provided at the Snake River projects with the intake gates. The intake diffusers were placed in the bulkhead slots just upstream of the intake gates. When used with the operating units, slow wicket gate closing times had to be used to avoid damaging surges in the intake water passages during a load rejection.

c. A copy of prototype tests made at Little Goose is inclosed. Much additional information is available from the North Pacific Division.

4. Paragraph 11 and Table 3. The project economics in this paragraph and in the table are misleading. A negative annual power betterment of \$1,822,368 cannot be substantiated by any of the recent efforts in negotiating a power betterment contract. This discussion and table should be qualified to indicate that based on the draft agreement of December 1975, the BCR is 1.4, and the final figure will depend upon the time of the negotiated contract.

DAEN-CWE-B(SANGE, 6 Feb 76) 2d Ind 21 June 1976

SUBJECT: Cooper River Rediversion Project, Lake Moultrie and Santee River,  
South Carolina, Supplement No. 2 to General Design Memorandum -  
Requirements for Protection of Bushy Park Reservoir

5. The subject report indicates that at those times when salt water intrusion threatens to affect the water quality at Bushy Park Reservoir, that the "Manual of Operation" for the Cooper River Rediversion Project prescribes procedures for permitting discharges from the Pinopolis Plant up to 5,000 c.f.s. In order to permit such an emergency operation to take place under the authority of this project, specific authorization must be obtained from the Secretary of the Army to allow such a discharge procedure to be incorporated into the "Manual of Operation."

FOR THE CHIEF OF ENGINEERS:



HOMER B. WILLIS

Chief, Engineering Division  
Directorate of Civil Works

1 Incl  
wd all incl  
Added 1 incl  
3. as

SADEN-GK (6 Feb 76) 3rd Ind  
SUBJECT: Cooper River Rediversion Project, Lake Moultrie and Santee  
River, South Carolina, Supplement No. 2 to General Design  
Memorandum - Requirements for Protection of Bushy Park  
Reservoir

DA, South Atlantic Division, Corps of Engineers, 510 Title Building,  
30 Pryor Street, S. W., Atlanta, Georgia 30303 4 November 1976

TO: District Engineer, Charleston, ATTN: SANGE

1. The second indorsement is referred for necessary action. The following additional guidance is offered:

a. Reference paragraph 2 of 2nd Indorsement: A mathematical model is warranted only if there is not sufficient information from physical model studies to provide the necessary operating guidelines. Information provided by the District (John Golden) indicates that a vigorous analysis of the physical model study results may provide the operating guidelines for the manual. A report on the physical model study by WES is being prepared by the District and will be distributed as a supplement to the GDM.

b. Reference paragraph 3.a. of 2nd Indorsement: Discussion on the use of slotted bulkheads should include the impact that velocities through the slots have on migratory fish. The experience of NPD (Mr. David Legg FTS 423-3764) may be helpful.

2. Your response should reach SADEN-GK by 15 ~~November~~ 1976.

FOR THE DIVISION ENGINEER:

1 Incl  
nc

*John C. Lytle Jr*  
WILLIAM N. McCORMICK, JR.  
Chief, Engineering Division

SACEN-G (6 Feb 76) 4th Ind

SUBJECT: Cooper River Rediversion Project, Lake Moultrie and Santee River, South Carolina, Supplement No. 2 to General Design Memorandum - Requirements for Protection of Bushy Park Reservoir

DA, Charleston District, Corps of Engineers, P. O. Box 919, Charleston, South Carolina 29402 1 September 1977

TO: Division Engineer, South Atlantic, ATTN: SADEN-GK

1. The information in the following paragraphs is in response to the comments in the preceding indorsements. The responses are referenced to paragraphs in first, second, and third indorsements.
2. First Indorsement, Paragraph a Concur. The District has informed local interests that there is a present potential for surges from hurricanes, earthquakes, etc. to enter the low areas along the lower reaches of Bushy Park and this condition will remain after project construction. However, should these or other uncontrollable forces occur it is planned to make such releases from Pinopolis that will reduce impacts on the Bushy Park Reservoir.
3. First Indorsement, Paragraph b Mileage figures shown in the report refer to the map shown on Plate 1 of this report and correspond to the same locations given in the EPA report although the mileages are different.
4. First Indorsement, Paragraph c Concur.
5. First Indorsement, Paragraph d Concur.
6. First Indorsement, Paragraph e Concur.
7. First Indorsement, Paragraph f Concur.
8. Second Indorsement, Paragraph 2, and Third Indorsement, Paragraph 1a The WES report on the model study has been distributed as an appendix to subject report.
9. Second Indorsement, Paragraph 3, and Third Indorsement, Paragraph 1b It appears that the mortality rate of anadromous fish (blueback Herring) would be very high through slotted bulkheads. SASEN will conduct detailed design studies of the emergency release facilities to determine the most feasible type of gate. The impact on migratory fish will be considered in the gate feasibility study. Completion date is about July 1978, results will be included in Cooling Water Facilities DM.

SACEN-G (6 Feb 76) 4th Ind

1 September 1977

SUBJECT: Cooper River Rediversion Project, Lake Moultrie and Santee  
River, South Carolina, Supplement No. 2 to General Design  
Memorandum - Requirements for Protection of Bushy Park  
Reservoir

10. Second Indorsement, Paragraph 4 New pages containing appropriate revisions to paragraph 11 and Table 3 are attached.

11. Second Indorsement, Paragraph 5 The operations manual will include provisions for 5000 cfs emergency release as permitted by the South Carolina Public Service Authority/Corps contract agreement for project operations.

12. Revised pages 3, 4, 5, 6, 7, and 8 are inclosed for substitution in the report.

FOR THE DISTRICT ENGINEER:

3 Incl

1 wd

Added 2 Incl

2. Revised Pages (17 cys)

3. 4th Ind (17 cys)

JACK J. LESEMANN

Chief, Engineering Division



**DEPARTMENT OF THE ARMY**

CHARLESTON DISTRICT, CORPS OF ENGINEERS  
P O BOX 919  
CHARLESTON, S.C. 29402

SANGE

6 February 1976

SUBJECT: Cooper River Rediversion Project, Lake Moultrie and Santee River, South Carolina, Supplement No. 2 to General Design Memorandum - Requirements for Protection of Bushy Park Reservoir

Division Engineer, South Atlantic  
ATTN: SADEN-PD

1. Transmitted are 23 copies of the subject supplemental report, submitted for review and approval in accordance with applicable provisions of ER 1110-2-1150.
2. This supplement is prepared to incorporate into the official project design document certain potential project impacts on Bushy Park Reservoir and appropriate remedial actions proposed as project responsibilities. The information in this supplement essentially summarizes that presented in the "Special Report on Water Quality at Bushy Park" dated 21 October 1975 and subsequent Indorsements 1, 2, and 3. The special report should be consulted for more extensive discussion of matters covered in this supplement.
3. This supplement contains applicable calculations reflecting the effect of the proposed improvements on the economic formulation for the approved project. It does not consider economic changes indicated by revised values in the SCPSA agreement now under review. However, for the benefit of reviewers an economic formulation is provided as a separate inclosure to this letter which does consider both the changes indicated in the agreement and this supplement.



SANGE

6 February 1976

SUBJECT: Cooper River Rediversion Project, Lake Moultrie and Santee River, South Carolina, Supplement No. 2 to General Design Memorandum - Requirements for Protection of Bushy Park Reservoir

4. Results of the 1974 Cooper River model studies for the project are presently being compiled by Waterways Experiment Station into a final report. It is planned to submit the final report as an appendix to this supplement when it becomes available.



HARRY S. WILSON, JR.  
Colonel, Corps of Engineers  
District Engineer

2 Incl

1. Supplement (23 cys)
2. Table A

Table A

COOPER RIVER REDIVERSION PROJECT  
 UP-DATED PROJECT ECONOMICS  
 3 FEBRUARY 1976  
 (OCTOBER 1975 PRICE LEVEL)

NOTE: This table reflects economic effect of changed values in the SCPSA agreement presently under review.

Annual Benefits: (26 November 1975 DTO)

Reduction in Harbor Maintenance	\$6,242,000
Benefits to Commercial Shipping	158,000
Reduction in Maintenance Cost of Navy Facilities	78,000
Net Fish and Wildlife Effects	266,000
Redevelopment Benefits	<u>240,000</u>
<u>Total Annual Benefits</u>	<u>\$6,984,000</u>

Annual Charges:

O & M Costs:

Project	\$ 641,600
Monitoring System	26,000
Project Cost Interest and Amortization @ 3½% for 50 yrs. with Interest During Construction	3,922,326
Power Deficit:	
84,000 kw @ \$13.65/kw	-1,146,600
110,000,000 kwh @ 12.35 mills/kwh	1,358,500
Future Unit	143,200
Monitoring System	5,000
Emergency Flow structure @ Pinopolis Dam	<u>8,000</u>
Total Annual Cost (with interest during construction)	<u>4,957,000</u>

Benefit - Cost Ratio:

<u>Benefits (Annual)</u>	=	<u>\$6,984,000</u>	=	1.41	<u>Use 1.4</u>
Costs (Annual)		<u>\$4,957,000</u>			

COOPER RIVER REDIVERSION PROJECT  
LAKE MOULTRIE AND SANTEE RIVER, SOUTH CAROLINA

Design Memorandum No. 1  
General Design Memorandum

Supplement No. 2

Requirements for Protection of Bushy Park Reservoir

TABLE OF CONTENTS

TEXT

	<u>Para. No.</u>	<u>Page No.</u>
INTRODUCTION		
Purpose	1	1
Authority	2	1
Pertinent Reference	3	1
Scope	4	1
DISCUSSION		
Bushy Park Reservoir	5	1
Concerns of Local Interest	6	2
Spring Tides and Hurricanes Effects	7	2
PROPOSED PROJECT IMPROVEMENTS		
Monitoring System	8	3
Emergency Flow Facility	9	4
ESTIMATES		
Estimate of Cost	10	6
Project Economics	11	6
CONCLUSIONS		
Conclusion	12	6
Recommendation	13	6

TABLES

	<u>Table No.</u>	<u>Page No.</u>
Stable Locations of 100 ppm Total Salt, River Mile	1	4
Detailed Cost Estimate	2	7
Up-Dated Project Economics	3	8

APPENDICES

	<u>Appendix No.</u>
Bushy Park Water Supply Tests	A

COOPER RIVER REDIVERSION PROJECT  
LAKE MOULTRIE AND SANTEE RIVER, SOUTH CAROLINA

Design Memorandum No. 1  
General Design Memorandum

Supplement No. 2  
Requirements for Protection of Bushy Park Reservoir

INTRODUCTION

1. Purpose. This supplemental report to the General Design Memorandum presents information and a recommendation regarding additional project requirements for protection of the Bushy Park Reservoir. These requirements were not specifically recognized in the basic document or Supplement No. 1.
2. Authority. This report is prepared in response to paragraph 2, 3rd Indorsement, dated 21 January 1976, Subject: Cooper River Rediversion Project, Lake Moultrie and Santee River, South Carolina, Special Report on Water Quality at Bushy Park.
3. Pertinent Reference. Cooper River Rediversion Project, Lake Moultrie and Santee River, South Carolina, Special Report on Water Quality at Bushy Park submitted 21 October 1975 with indorsements 1, 2 and 3.
4. Scope. This report is prepared to incorporate into the official project design document certain additional proposed requirements and corrective measures involving water quality protection of Bushy Park Reservoir. A more definitive discussion of this matter is documented in the reference in paragraph 3, above.

DISCUSSION

5. Bushy Park Reservoir. The reservoir is part of the postwar industrial development primarily involving the City of Charleston. The reservoir contains about 8,500 acre-feet of water and covers about 850 acres. The water rights belong to the City of Charleston. The reservoir is a backup facility for the City's distribution system which is presently supplied by ample water from the Edisto River. Bushy Park Reservoir presently provides only raw water to industrial sources mostly at the Bushy Park Industrial area. Long term contracts with the industrial users provide the City significant revenue which is utilized for maintenance and development of the water supply system under the direction of the Commissioners of Public Works. The reservoir was formed by damming the Back River, about a mile above its confluence with the Cooper River. Fresh water is supplied from Cooper River thru a man made canal (Durham Canal) at the upper end of the Bushy Park industrial complex. See Plate 1.

6. Concerns of Local Interests. Concerns about possible project adverse effects to the Bushy Park Reservoir have been voiced primarily by the Cooper River Water Users Association (CRWUA) and City officials. Their concerns were effectively presented at a meeting of representatives from the Corps, City, CRWUA and State Ports Authority in Senator Strom Thurmond's office in Washington on 5 September 1975. From this meeting and immediate subsequent contacts the following expressed requests by the officials evolved.

a. The Corps should provide a proper monitoring system with sufficiently sophisticated devices to assure timely warning of a salinity threat to Bushy Park Reservoir after the redirection project is placed in operation.

b. The Corps should provide guaranteed protection of the Bushy Park Reservoir from ocean salinity intrusion under all conditions including spring tides and hurricanes. The degree of protection should be comparable to current capability. The protection may be provided by assurances of increased flows through the Pinopolis Hydro Plant owned by the South Carolina Public Service Authority (SCPSA) up to maximum plant capability to prevent ocean salinity from moving up the Cooper River and threatening Bushy Park Reservoir. Procedures for this activity should be specifically included in the "Manual of Operation" for the project. Structural alternatives to protect Bushy Park Reservoir were discussed to a lesser degree and would be acceptable if they were compatible with water supply utilization requirements from the reservoir.

c. The Corps should provide facilities necessary to assure the capability of discharging up to 3,000 cfs (and possibly up to 5,000 cfs) through the Pinopolis Hydro Plant in the event flow through the turbines is prohibited, as was the case following the control room fire in February 1970 (after the fire, only 1,132 cfs could be discharged into Cooper River through the lock filling system at the hydro plant for a period of two weeks).

The requests in subparagraphs a and b above have been satisfied by the commitments indicated in the revised inclosure to the 3rd Indorsement, dated 21 January 1976, Subject: Cooper River Rediversion Project, Lake Moultrie and Santee River, South Carolina, Special Report on Water Quality at Bushy Park.

The items indicated by requests in subparagraphs a and c are discussed in detail in the following paragraphs 8 and 9.

7. Spring Tides and Hurricane Effects. In response to comment 2e, 1st Indorsement to the special report reference in paragraph 3 above, the following explanation is furnished regarding spring tides and hurricane effects on salinity intrusion in the Cooper River near Bushy Park.

Spring tides were considered in the model tests for the project and their effect is reflected in the results shown in the following Table 1. The model was not sophisticated enough to produce actual oceanic tide variations. Rather, in order to consider the most adverse potential condition, all tests were conducted with a continuous reproduction of an average spring tide having a range of approximately 6.0 ft. in Charleston Harbor at the Custom House (HW elevation = 6.3 ft; LW elevation = 0.3 ft.) Even though spring tides may advance salinity up the Cooper River to some extent, the model tests and prototype tests have indicated that it will not advance sufficiently to cause water to enter the Bushy Park Reservoir.

Hurricane surge studies for Charleston Harbor and its tributaries are currently underway at the Coastal Engineering Research Center. The predicted elevation of the hurricane surge in the Bushy Park area has not yet been finalized, however it is probable that the surge from a severe hurricane will enter the reservoir across a low area in the industrial park, just downstream of Cote Bas at about river mile 32.6 (See Plate 1).

#### PROPOSED PROJECT IMPROVEMENTS

8. Monitoring System. When the Cooper River Rediversion Project becomes operational, the decreased flow of fresh water in the Cooper River will be accompanied by an upstream migration of the ocean salinity front to a general location much nearer the entrance to Bushy Park Reservoir. This fact has caused much concern about the increased possibility of saline pollution of the Bushy Park Reservoir. As a means of safeguarding against such an occurrence, a monitoring system for detecting salinity intrusion has been devised as a procedure to be adopted which will provide for special releases at Pinopolis Dam to repel any serious salt water intrusion threat to the reservoir.

The main objective of the monitoring system will be to provide an early warning of a possible salt water pollution threat to Bushy Park Reservoir. In the event that such a threat should occur, the telemetry system would include an alarm signal to alert the dam operator at the Pinopolis Powerhouse to take appropriate action as indicated by predetermined emergency operating procedures. A study would be performed to prepare an "Operations Manual" which would describe actions to be taken under various possible salinity conditions in the Cooper River. In the formulation of this plan, it was decided that a system of four monitoring stations are needed.

The selection of the sites for the initial installation of monitors was based on results of studies conducted by the Environmental Protection Agency. These studies were performed during a 10-day test period when the discharge at Pinopolis Dam was limited to 3,000 cfs in order to approximate post-rediversion conditions of flow. Results from these studies show that the maximum intrusion of salt water (as determined by chloride ion concentration) on a high slack tide was between river miles 32.6 and 38.5. The entrance to the Bush Park Reservoir is at river mile 43.2. In view of this, monitoring stations

would be established below the Verona outfall at river mile 27, at Cote Bas (river mile 33.2), and at Dean Hall (river mile 38.5). Telemeter systems would be used at the two lowermost stations to provide a direct readout of data at Pinopolis Dam and under certain conditions, to activate an alarm to alert the dam operator. An additional monitor would be located within the Bushy Park Canal to monitor water entering the Bushy Park Reservoir. The monitors in the Cooper River would measure chloride ion concentration, conductivity, and temperature at the middle and bottom depths of the river. The monitor in the Bushy Park Canal would measure the same parameters at the bottom only.

Detailed design of the monitoring system would be presented in the forthcoming feature design memorandum for Water Quality monitoring. The total initial cost is estimated to be \$126,000. Operation and maintenance cost is estimated to be \$26,000 annually. See Table 2 for details of costs.

9. Emergency Flow Facility. Under present operating conditions an average of about 15,600 cfs of fresh water flows from Lake Moultrie through the Pinopolis hydro plant into the Cooper River. This high flow causes the salinity front to stabilize well below the Bushy Park Canal entrance. However, with flows through Pinopolis reduced to 3,000 cfs the salinity front will migrate much closer to the canal entrance. The following Table 1 developed from WES model studies is presented to illustrate the comparable conditions. The table shows Schedule A as present operating condition and Schedule C as the most severe post-project operating condition ( 3 consecutive days zero flow). The WES report on the model study has been distributed as an appendix to this report.

Table 1

Stable Locations of 100 ppm Total Salt, River Mile

Test Schedule	Daily Average FW, cfs	Low Water Slack		High Water Slack	
		Surface RM	Bottom RM	Surface RM	Bottom RM
A	15,600	18.0	21.0	23.0	25.0
C	3,000	35.0	36.0	40.0	40.5

Various alternatives have been considered as a possible solution to the problem of being able to pass up to 5,000 cfs through the Pinopolis hydro plant when operation of the generating units is impossible due to

some unexpected emergency condition. These alternatives included possible use of the filling and emptying system of the navigation lock, an additional outlet structure through the embankment near the powerhouse, and the use of the "empty stall" which was provided during initial construction for installation of a fifth hydro unit. This fifth unit has not been installed and the project agreement with SCPSA will preclude any future hydro unit installation in the "empty stall".

The navigation lock or an additional outlet structure were ruled out as solutions to the above stated problem. It was determined that only 1,100 cfs of controlled flow could be passed through the lock filling system. An outlet structure which would require a side channel spillway was considered much too costly.

In evaluating the use of the empty stall, two approaches were taken. One was the installation of wicket gates and appurtenant parts and control system. A preliminary cost based upon a manufacturer's estimate revealed that this approach would cost in excess of \$1,000,000. The second study entailed the use of one existing wheeled intake gate to control the flow. The SCPSA indicated that these gates were not designed to be raised against an unbalanced head. Therefore to use one of the gates would require modifications to the gate and intake gantry crane. For purposes of this study, however, it was decided to propose the second approach and to consider the highest reasonable cost arrangement - the cost of a new gate, modification of the gantry crane, and a concrete slab over the turbine pit which would be required in either case. The total cost of the above scheme is \$200,000, as shown in detail in Table 2. An annual operations and maintenance cost for this item is not listed because of its insignificance, particularly in relation to the accuracy of the estimate.

More recent investigations with SCPSA regarding this matter indicate that the present intake gates may have been designed for operation against an unbalanced head. Should this be true, the cost could be considerably reduced. It is planned to pursue this aspect during detailed design of the emergency flow facility, if approved. Detail studies would be presented in the feature design memorandum presently scheduled to cover design of the cooling water system at Pinopolis.

Per instruction in the 3rd Indorsement to the referenced special report in paragraph 3 above, a supplement to the SCPSA agreement would be transacted to cover appropriate arrangements for implementing the above scheme for the emergency flow facility. The scheme has been discussed with responsible officials of SCPSA and they have indicated a desire to cooperate with the District in the scheme implementation. Since it would involve an alteration to the Pinopolis hydro plant SCPSA would be given the opportunity to approve contract plans and construction.

## ESTIMATES

10. Estimate of cost. The cost estimate for the Bushy Park monitoring system is based on prices quoted by a prominent manufacturer. The figures quoted were for monitoring units which would provide the data desired. The following Table 2 presents the total project Permanent Operating Equipment (Cost Account 20) detailed cost estimate updated from GDM Supplement No. 1, p. 30, and including the Bushy Park protection features discussed in this report. The total initial cost of the protection features is \$326,000. Total annual operation and maintenance cost is \$26,000.

11. Project Economics. The revised project economic formulation updated to October 1975 price levels and including costs for the protection features proposed in this report shows Annual Benefits of \$6,984,000, Annual Costs of \$4,957,000 and Benefit to Cost Ratio of 2.4. The following Table 3 presents a breakdown of the updated project economics. Power values are based on the draft Corps/SCPSA agreement dated 2 Dec 1975. Final computations will depend on provisions and values of consummated agreement.

## CONCLUSIONS

12. Conclusion. As a result of the comments in the indorsement to the report referenced in paragraph 3 above (including the draft reply to Senator Thurmond inclosed with the 3rd Indorsement), it is presumed that the District has been given authority to include corrective actions indicated by the requests of local officials described in subparagraphs 6a and 6b, above as project requirements. The corrective action involving the emergency flow facility at Pinopolis Hydro Plant as described herein is proposed as a project requirement.

13. Recommendation: It is recommended that (1) the proposed protective features for Bushy Park be adopted as part of the project plan and (2) the information presented in this supplement be used as a basis for developing appropriate detail design preparatory to construction of the proposed items.

Table 2  
 COOPER RIVER REDIVERSION PROJECT  
 HYDRO PLAN  
 COOPER RIVER SALINITY CONTROL  
 DETAILED COST ESTIMATE  
 (October 1975 price levels)

Cost Account	Feature	Unit	Quantity	Unit Cost	Total Cost
20.	PERMANENT OPERATING EQUIPMENT				
.1	Monitoring system				
	Equipment				
	Monitor	Ea.	4	\$15,000	\$60,000
	Telemeter system	Ea.	2	12,000	24,000
	Monitor shelter	Ea.	4	3,000	12,000
	Land lease	LS	Job		5,000
	Subtotal direct costs				<u>\$101,000</u>
	Contingencies, 25%				25,000
	Total Cost				<u>\$126,000</u>
.2	Emergency flow facility				
	Emergency gate	Ea.	1	\$96,000	\$ 96,000
	Concrete slab	LS	Job		24,000
	Rehabilitate existing gantry crane	LS	Job		40,000
	Subtotal direct cost				<u>\$160,000</u>
	Contingencies, 25%				40,000
	Total cost				<u>\$200,000</u>
.3	Miscellaneous (from Table 4 GDM				
	Suppl No. 1, Oct. '73)	LS	Job		<u>\$139,000</u>
	Subtotal				\$139,000
	Contingencies, 15%				<u>20,000</u>
	Total cost				<u>\$159,000</u>
	Account 20. total				\$485,000
	Monitoring system operation (52 man-days for GS-9 per year)	LS	Job		\$ 6,000
	Monitoring system maintenance	LS	Job		<u>20,000</u>
	Total annual O&M cost				<u>\$ 26,000</u>

Table 3

COOPER RIVER REDIVERSION PROJECT  
UP-DATED PROJECT ECONOMICS  
3 FEBRUARY 1976

(OCTOBER 1975 PRICE LEVEL)

NOTE: This table reflects economic effect of values in the SCPSA agreement draft dated 2 Dec 1975. The final computations will depend on provisions and values of consummated agreement.

Annual Benefits: (26 November 1975 DT0)

Reduction in Harbor Maintenance	\$6,242,000
Benefits to Commercial Shipping	158,000
Reduction in Maintenance Cost of Navy Facilities	78,000
Net Fish and Wildlife Effects	266,000
Redevelopment Benefits	<u>240,000</u>
<u>Total Annual Benefits</u>	<u>\$6,984,000</u>

Annual Charges:

O & M Costs:	
Project	\$ 641,600
Monitoring System	26,000
Project Cost Interest and Amortization @ 3½% for 50 yrs. with Interest During Construction	3,922,326
Power Deficit:	
84,000 kw @ \$13.65/kw	-1,146,600
110,000,000 kwh @ 12.35 mills/kwh	1,358,500
Future Unit	143,200
Monitoring System	5,000
Emergency Flow structure @ Pinopolis Dam	<u>8,000</u>
<u>Total Annual Cost (with interest during construction)</u>	<u>4,957,000</u>

Benefit-Cost Ratio:

$$\frac{\text{Benefits (Annual)}}{\text{Costs (Annual)}} = \frac{\$6,984,000}{\$4,957,000} = 1.41 \quad \text{Use } \underline{\underline{1.4}}$$

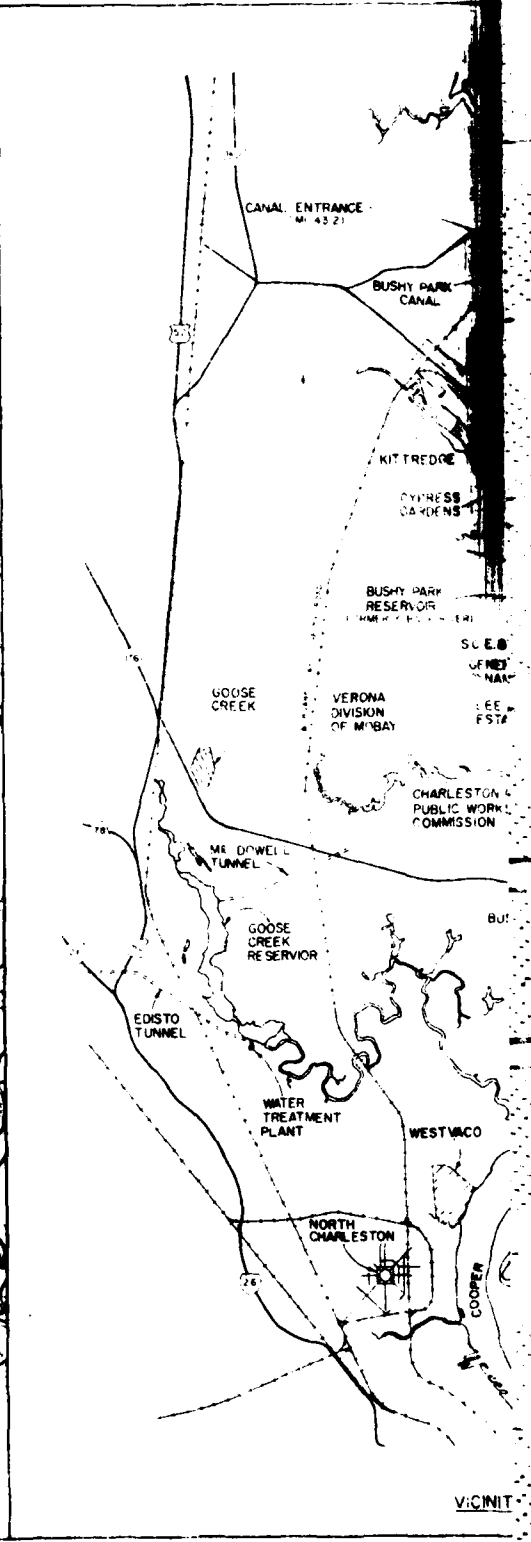
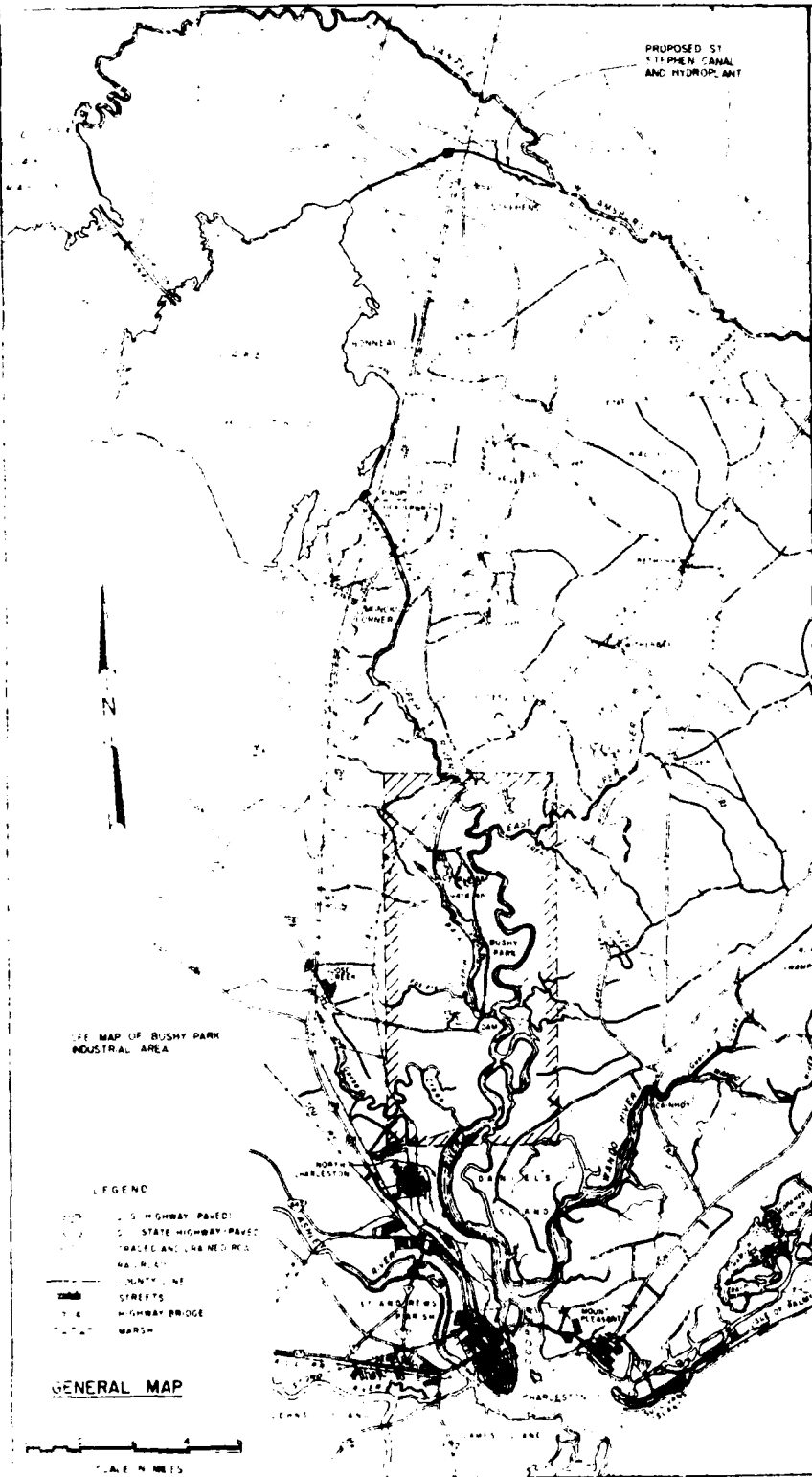

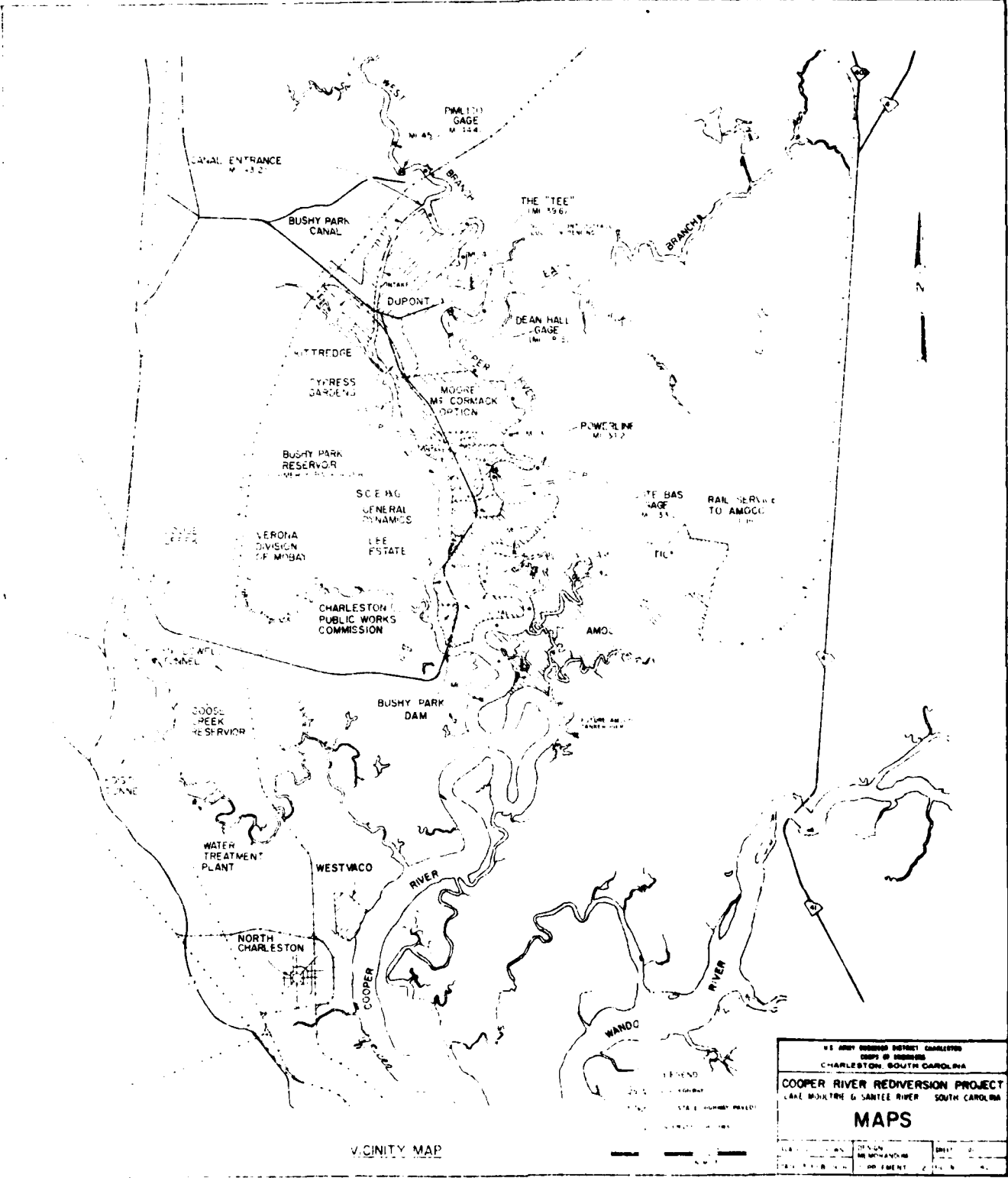

VICINITY MAP

U.S. ARMY ENGINEER DISTRICT CHARLESTON  
 CORPS OF ENGINEERS  
 CHARLESTON, SOUTH CAROLINA

**COOPER RIVER REDIVERSION PROJECT**  
 LAKE MOUNTAIN & Santee River SOUTH CAROLINA

**MAPS**

SCALE	1:50,000	SHEET	2
DATE	1954	PROJECT	2

PLATE I

2

APPENDIX A  
SUPPLEMENT NO. 2

DESIGN MEMORANDUM NO. 1  
GENERAL DESIGN

COOPER RIVER REDIVERSION PROJECT  
LAKE MOULTRIE & SANTEE RIVER  
SOUTH CAROLINA

BUSHY PARK  
WATER SUPPLY TESTS

U. S. ARMY ENGINEER DISTRICT, CHARLESTON  
CORPS OF ENGINEERS  
CHARLESTON, SOUTH CAROLINA

PREPARED BY  
U. S. ARMY WATERWAYS EXPERIMENT STATION  
CORPS OF ENGINEERS  
VICKSBURG, MISSISSIPPI  
MARCH 1976

CONVERSION FACTORS, U. S. CUSTOMARY TO METRIC (SI)  
UNITS OF MEASUREMENT

U. S. customary units of measurement used in this report can be converted to metric (SI) units as follows:

<u>Multiply</u>	<u>By</u>	<u>To Obtain</u>
inches	2.54	centimetres
feet	0.3048	metres
miles (U. S. statute)	1.609344	kilometres
square feet	0.092903	square metres
square miles (U. S. statute)	2.58999	square kilometres
cubic yards	0.764555	cubic metres
feet per second	0.3048	metres per second
cubic feet per second	0.02831685	cubic metres per second

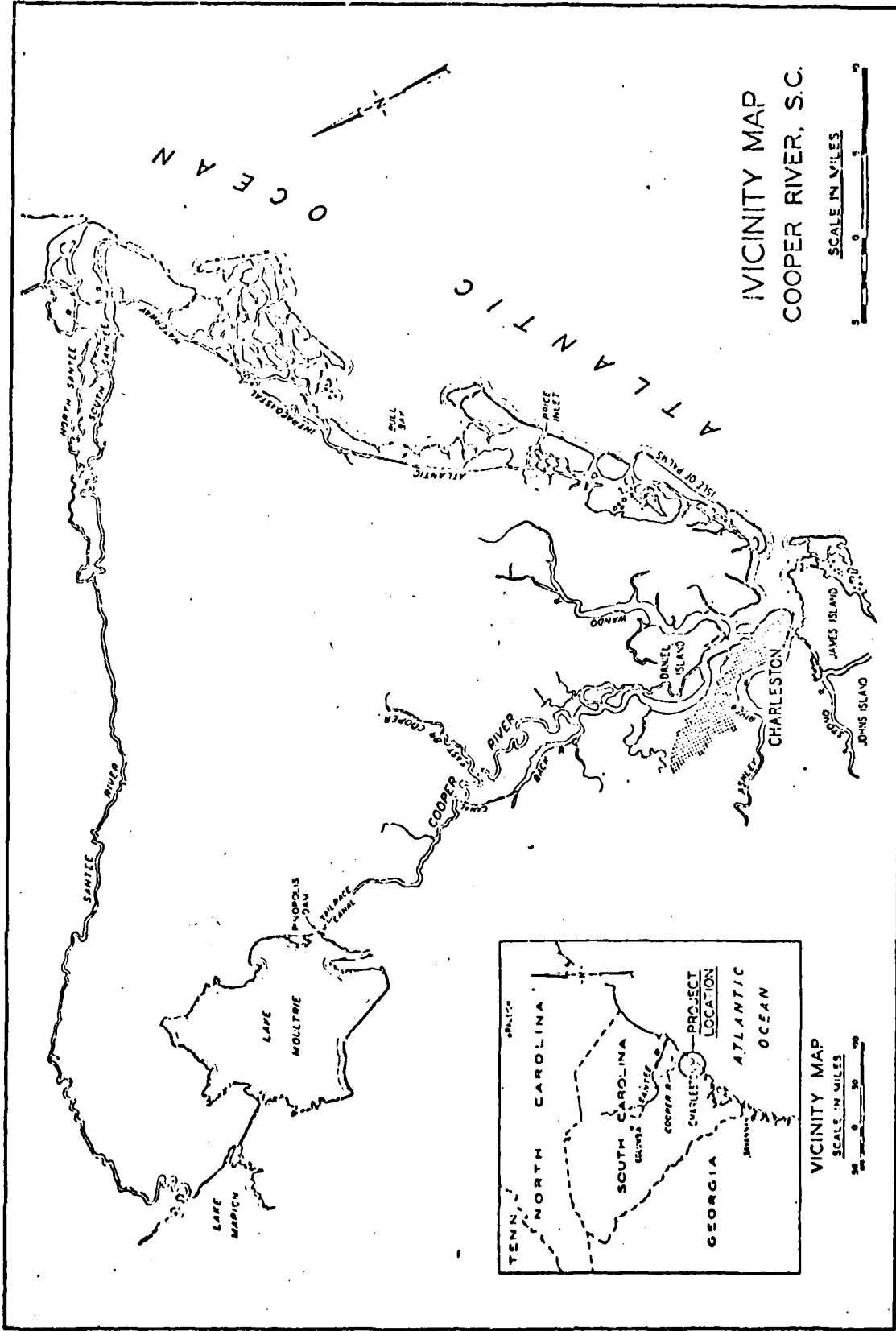

Figure 1. Vicinity map

COOPER RIVER REDIVERSION PROJECT  
BUSHY PARK WATER SUPPLY TESTS  
Hydraulic Model Investigation

PART I: INTRODUCTION

The Prototype

1. Charleston Harbor, an important South Carolina seaport, is located on the Atlantic Coast about 110 miles\* southwest of the North Carolina-South Carolina state line, and is formed by the junction of the Ashley, Wando, and Cooper Rivers as shown in Figure 1. Prior to 1940, the estuary had a drainage area of about 1400 square miles, and the average freshwater inflow from all tributaries was on the order of 415 cfs (261 cfs from Ashley River, 82 cfs from Wando, and 72 cfs from Cooper River). The estuary was of the homogeneous type, being almost entirely salt water. Construction of the Santee-Cooper Hydroelectric Project was begun in 1940 and completed in 1942 and included a dam in the West Branch of the Cooper River at Pinopolis, SC, and diversion of Santee River flow through the Pinopolis power plant into the West Branch of the Cooper River. The drainage area of the Charleston estuary was thus increased to about 16,000 square miles, and the average annual freshwater inflow of the Cooper River was increased from 72 cfs to about 15,000 cfs. The estuary was changed to a partially mixed type, and density currents became a controlling factor with respect to shoaling in the harbor. Prior to completion of the Santee-Cooper power project, maintenance dredging in Charleston Harbor averaged about 180,000 cu yd per year. Since completion of the project, annual maintenance requirements in the navigation channels steadily increased up to 10,000,000 cu yd at the present time. The results of previous studies indicated that rediversion of a major portion of the Santee River flow from Cooper River back to the Santee

---

\* A table of factors for converting U. S. customary units of measurement to metric (SI) units is presented on page 3.

River is the best way to obtain a substantial reduction in maintenance dredging in Charleston Harbor. However, continuation of as much flow as possible through Pinopolis was considered desirable to minimize change to the Cooper River and harbor environment and to accommodate downstream needs of Bushy Park Reservoir at mile 43 and the Jefferies Steam Electric Generating Plant just below Pinopolis. The existing Cooper River Federal navigation channel and the portion maintained by the Navy have project depths of -35 ft mlw\*.

#### Purpose of Model Study

2. The purpose of the model study was to determine the effects on tidal heights, current velocities, and salinities of various weekly hydrographs at Pinopolis which could result from the proposed redirection project. The existing hydrograph has a weekly average flow of 15,600 cfs. Five suggested redirection schedules were tested, including three with a weekly average flow of 3000 cfs and two with a weekly average flow of 3500 cfs.

---

\* In this report, mlw refers to mean low water for the Custom House tide gage located on the Charleston waterfront (gage CR2 as shown in Plate 2).

## PART II: THE MODEL

### Description

3. The Charleston Harbor model reproduced the entire tidal portions of the Ashley, Cooper, and Wando Rivers and a portion of the Atlantic Ocean within the limits shown in Plate 1. The Ashley and Wando Rivers and the East Branch of the Cooper were reproduced to correct lengths and cross sections, but, in order to conserve space, were realigned to conform to the general alignment of the Cooper River.

4. The model was constructed to linear scale ratios, model to prototype, of 1:2000 horizontally and 1:100 vertically. These scale ratios fixed the following model-to-prototype relations: slope, 20:1; velocity, 1:10; time, 1:200; discharge, 1:2,000,000; and volume, 1:400,000,000. The salinity scale ratio was 1:1, and the model ocean supply was maintained at a salinity of 30,000 parts per million (ppm) total salts. One prototype tidal cycle of 12 hr and 25 min was reproduced in the model in 3.725 min. The model was approximately 137 ft long, 46 ft wide at the widest point, and covered an area of about 3600 sq ft. It was constructed within a shelter to protect it from the weather and to permit uninterrupted operation.

### Model Appurtenances

5. The model was equipped with the necessary appurtenances to reproduce and measure all pertinent phenomena such as tidal elevations, saltwater concentrations, current velocities, freshwater inflows, and dye concentrations. Apparatus used in connection with the reproduction and measurement of these phenomena included an automatic tide generator and recorder, tide gages, conductivity (salinity) meters, chemical titration equipment, current velocity meters, freshwater inflow measuring devices, skimming and measuring weirs, and fluorometers for dye concentration determinations.

#### Tide generator and recorder

6. The reproduction of tidal action in the model was accomplished by means of a tide generator, located in the model ocean, which maintained a differential between a pumped inflow of salt water to the model and a gravity return flow to the supply sump as required to reproduce all characteristics of the prototype tides at the ocean control tide gage. A schematic drawing of the operation of this system is presented in Figure 2.

#### Tide gages

7. Automatic water surface transmitters were installed at the locations shown in Plate 2. Brush recorders were used to record the tidal elevations throughout the model. Portable point gages were used to measure tidal elevations at special points of interest.

#### Salinity meters

8. All salinity concentrations of samples taken from the model throughout the various tests with a concentration in excess of about 1.0 parts per thousand (ppt) were determined by use of salinity meters consisting primarily of conductivity cells especially built and calibrated for this purpose. The salinity meter is shown in Figure 3. One cell was used for salinities between 1.0 and 1.5 ppt; a second cell covered the range from 1.5 up to about 20.0 ppt; while a third cell was used for values greater than 20.0 ppt. The accuracy of the salinity meters is  $\pm 2$  percent of full scale above 1.0 ppt. The values were determined by chemical titration when concentrations were less than about 1.0 ppt.

#### Chemical titration equipment

9. This method of determining salinity concentration was used primarily to determine the salinity concentrations in critical areas known to be less than 1.0 ppt, for periodic calibration checks of the salinity meters, and to insure that a constant source salinity was maintained in the ocean supply sump. The titration equipment consisted of a graduated burette for measuring the volume of silver nitrate required to precipitate the salt, pipettes for measuring the volume of each sample, sample jars in which to perform the titration, a supply of

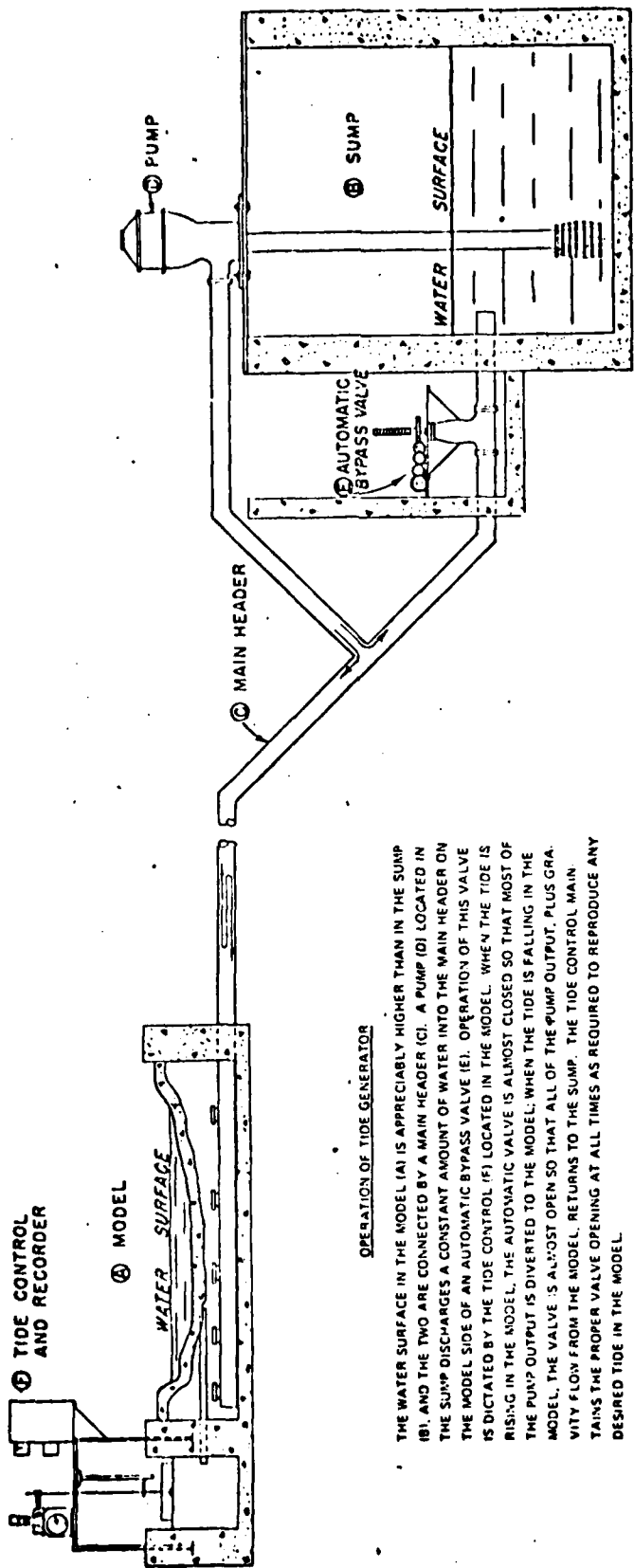

OPERATION OF TIDE GENERATOR

THE WATER SURFACE IN THE MODEL (A) IS APPRECIABLY HIGHER THAN IN THE SUMP (B), AND THE TWO ARE CONNECTED BY A MAIN HEADER (C). A PUMP (D) LOCATED IN THE SUMP DISCHARGES A CONSTANT AMOUNT OF WATER INTO THE MAIN HEADER ON THE MODEL SIDE OF AN AUTOMATIC BYPASS VALVE (E). OPERATION OF THIS VALVE IS DICTATED BY THE TIDE CONTROL (F) LOCATED IN THE MODEL. WHEN THE TIDE IS RISING IN THE MODEL, THE AUTOMATIC VALVE IS ALMOST CLOSED SO THAT MOST OF THE PUMP OUTPUT IS DIVERTED TO THE MODEL; WHEN THE TIDE IS FALLING IN THE MODEL, THE VALVE IS ALMOST OPEN SO THAT ALL OF THE PUMP OUTPUT, PLUS GRAVITY FLOW FROM THE MODEL, RETURNS TO THE SUMP. THE TIDE CONTROL MAINTAINS THE PROPER VALVE OPENING AT ALL TIMES AS REQUIRED TO REPRODUCE ANY DESIRED TIDE IN THE MODEL.

Figure 2. Schematic diagram of a typical tide generating system

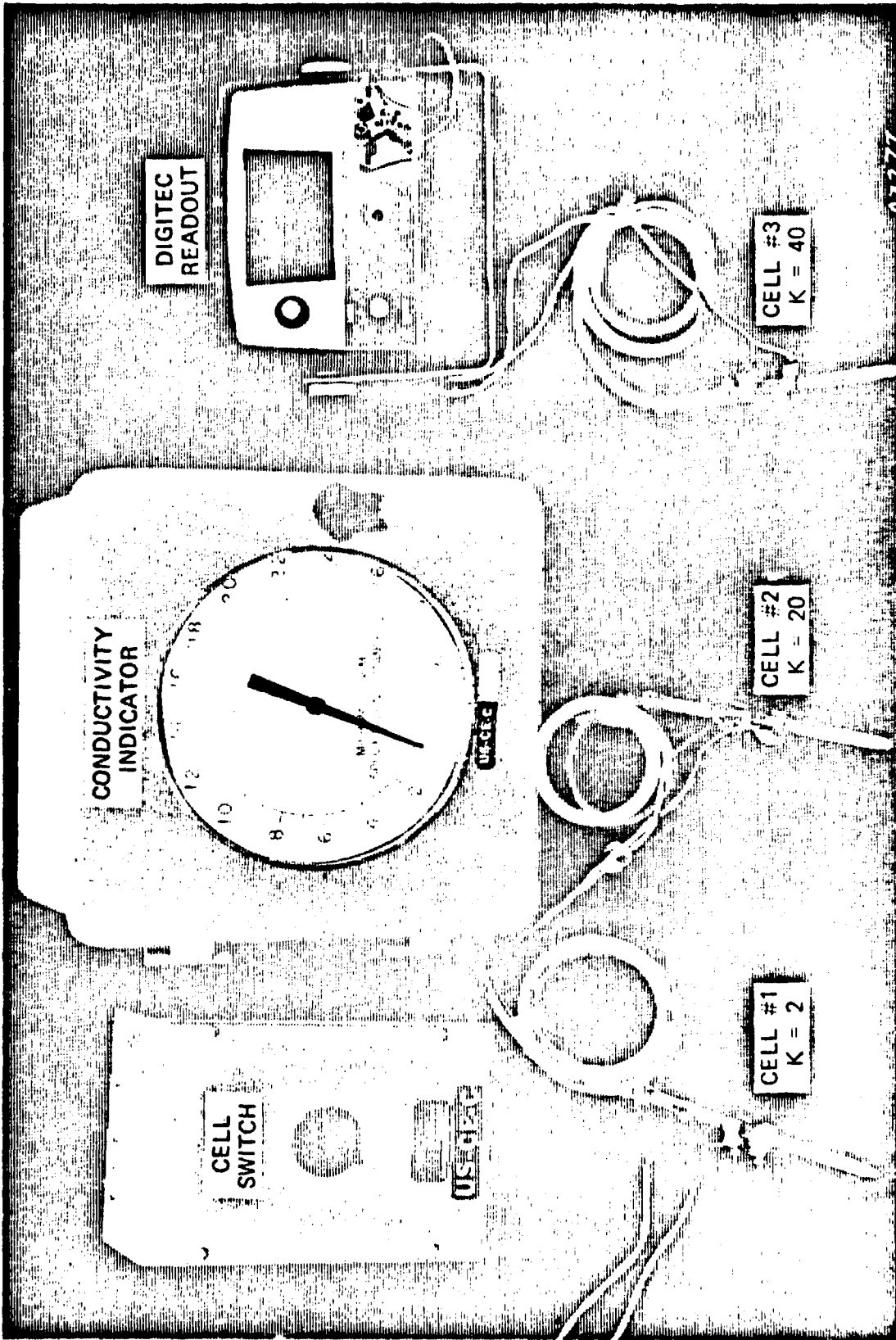

Figure 3. Salinity meter

silver nitrate, and a quantity of potassium chromate for use as an end-point indicator in the titration process. The method consisted of adding a known concentration of silver nitrate solution to a known volume of the model salinity sample; the amount of silver nitrate required to precipitate the salt contained in the sample was then converted to salinity in parts per thousand. The accuracy of the titration process was within  $\pm 0.1$  ppt.

#### Current velocity meters

10. Current velocity measurements were obtained with miniature Price-type current meters (Figure 4). The five meter cups, constructed of either a light plastic or a metal material, were approximately 0.04 ft (4.0 ft prototype) in diameter and were mounted on a horizontal wheel 0.09 ft in diameter; the center of the cups was 0.05 ft (5.0 ft prototype) from the bottom of the frame. The meters were calibrated frequently to ensure accurate operation and were capable of measuring actual velocities as low as 0.03 fps (0.3 fps prototype).

#### Freshwater inflow measuring devices

11. All rivers with freshwater inflows were equipped with a constant head tank and either rotometers or Van Leer weirs for precise measurements of the respective flows. The Cooper River control at Pinopolis was equipped with a quick-opening valve to make it possible to simulate the flow changes dictated by the power-generating schedule being tested.

#### Skimming weir

12. A portion of the mixed salt water and fresh water that accumulated in the model ocean had to be wasted in order to maintain a constant volume. This was accomplished by means of a skimming weir that removed a quantity of water equal to the total of the freshwater inflows. Precise measurement of the discharge over the skimming weir was made by means of a Van Leer weir.

#### Limitations of the accuracy of model measurements

13. Measurements of tidal elevations in the model were made with point gages graduated to 0.001 ft, or 0.1 ft prototype, and with automatic

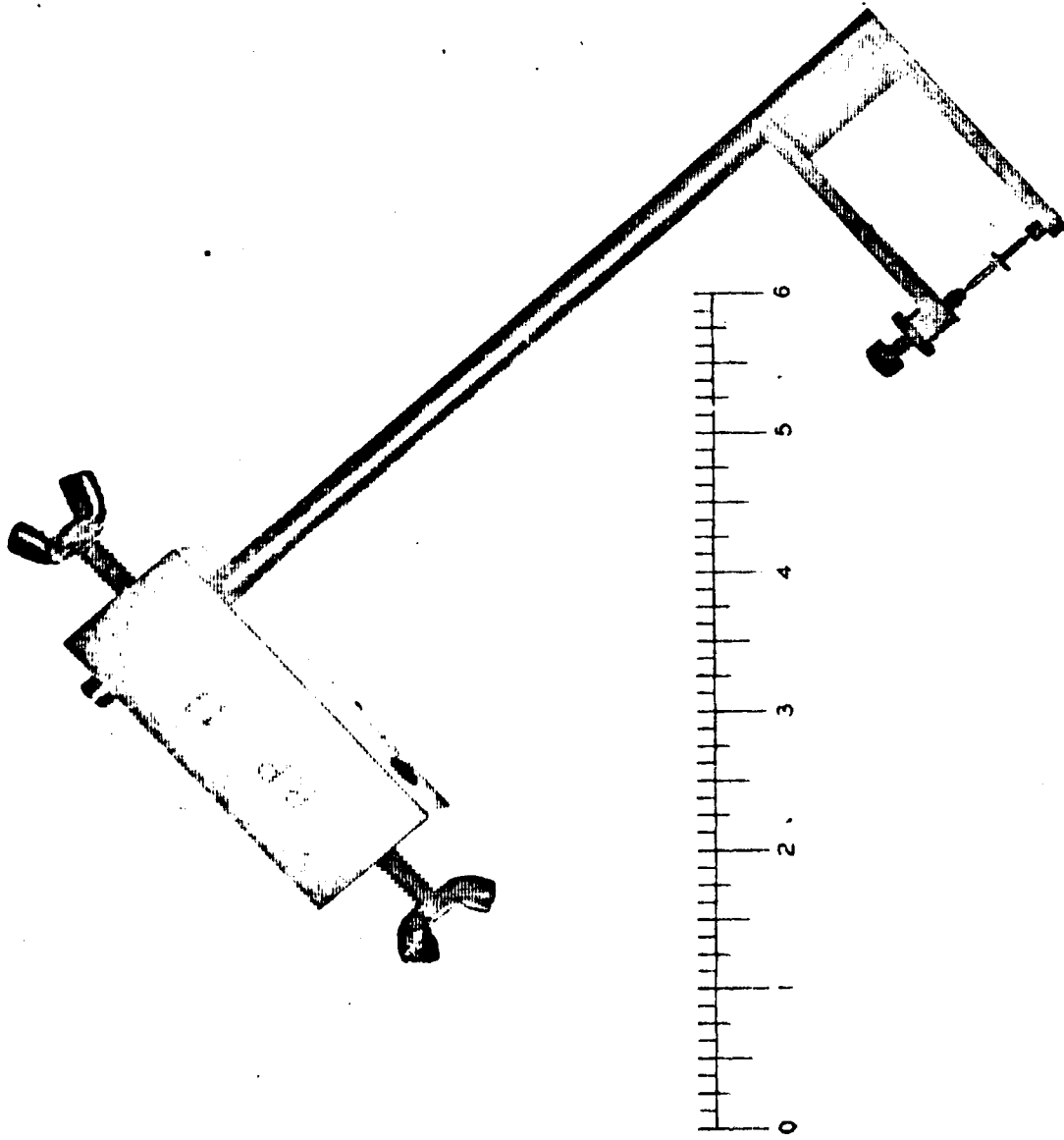

Figure 4. Miniature Price-type current meter

water-level transmitters, also graduated to 0.1 ft prototype. The limitations of the current velocity meters used in the model were mainly due to the size of the meter with respect to the 1:2000 horizontal scale to which the model was constructed. The horizontal spread of the entire meter cup wheel was about 0.11 ft in the model, which represents about 220 ft in the prototype, as compared with a horizontal distance of about 1.0 ft for prototype meters. The height of the meter cup was about 0.04 ft (4.0 ft prototype) as compared with only a few inches in prototype meters. The center line of the meter cup was about 0.05 ft above the bottom of the frame; therefore, bottom velocity measurements in the model were actually obtained at a point 5.0 ft (prototype) above the bottom, instead of about 2.0 ft above the bottom as usually obtained in prototype velocity measurements. The model velocities were determined by counting the number of revolutions of one meter cup in a 10-sec interval, which represented a period of about 33 min prototype, as compared with about 1-min observations in the prototype. Three or more model observations were averaged in an attempt to obtain the best data possible. In a physical model constructed to a 1:2000-horizontal scale, the critical feature in obtaining truly comparable base and plan test current measurements lies in the technicians' ability to locate the meter at exactly the same position in the cross section each time measurements are made. Horizontal errors in meter location in the order of 0.01 to 0.05 ft can result in large velocity differences, particularly in a narrow, sinuous channel such as Cooper River. This should be kept in mind when comparing corresponding velocity measurements.

### PART III: TESTS AND RESULTS

14. Tests were conducted for six freshwater flow conditions at Pinopolis with the existing 35- by 600-ft Cooper River navigation channel. Freshwater inflows for the Ashley and Wando Rivers remained constant for all tests at 261 cfs and 82 cfs, respectively. All tests were conducted with a continuous reproduction of an average spring tide having a range of approximately 6.0 ft at Custom House (HW elevation = 6.3 ft; LW elevation = 0.3 ft). The model was operated with an ocean source salinity of 30,000 ppm.

15. For all tests, a combined withdrawal of 1150 cfs was pumped from Bushy Park Reservoir to simulate water usage by Charleston and industries located in the Industrial Park. Of the total withdrawal, 200 cfs was for the Charleston Public Works and was returned to the estuary at the City of Charleston at approximately the mouth of the Ashley River. A second 200 cfs, withdrawn for the Vernona Plant, was returned to the Cooper River at approximately mile 29. The withdrawal for the South Carolina Electric and Gas plant amounted to 750 cfs and was returned to the Cooper River at approximately mile 33. The locations of the various intakes and outfalls are shown in Plate 1.

16. Maps showing the locations of the tide, salinity, and velocity stations are shown in Plates 2 and 3. For all tests the model was operated until stable salinity conditions were obtained before any reported data were taken. This was achieved by operating the model with a constant freshwater inflow for a period of approximately 60 tidal cycles, or until the model consistently reproduced the hydraulic and salinity phenomena with respect to location and phase of the tidal cycle. The proposed weekly hydrograph was then started and continued throughout the remainder of the test.

17. The only differences between tests are the changes in daily Pinopolis releases dictated by the six weekly hydrographs that were reproduced. For the first test, a modification of the existing Cooper River average daily inflow which averaged 15,600 cfs for the week

(Schedule A) was reproduced. The model hydrograph is shown in Columns "M" of Table 1 along with corresponding prototype values listed in Columns "P." Inspection of the hourly prototype flows shows that several significant flow changes occur each day. The flow changes result from variations in the demand for electricity. Detailed reproduction of such a daily hydrograph in the model was not practical due to the time scale of the model; therefore, the simplified hydrograph shown in Columns "M" of Table 1 was used for the model tests. The model values were obtained by averaging the periods of relatively uniform discharges shown in Columns "P" of Table 1.

18. For the second test, the proposed Cooper River redirection weekly hydrograph shown in Table 2 (Schedule B) was reproduced. The proposed flows consisted of sustained flows of 1325 cfs each Sunday, with sustained flows of 3279 cfs for the remaining six days of the week. The average inflow for the week was 3000 cfs.

19. The third test was conducted with the proposed Cooper River redirection weekly hydrograph shown in Table 3 (Schedule C). This hydrograph invited maximum upstream intrusion of the salinity front during a generating week. The proposed flows consisted of zero flow for the 72-hr period from midnight Saturday to midnight Tuesday and a daily average flow of 5250 cfs for the remaining four days of the week. Schedule C also resulted in an average inflow of 3000 cfs for the week.

20. The fourth test was conducted with the proposed Cooper River redirection weekly hydrograph shown in Table 4 (Schedule D). This hydrograph involved a sustained flow of 1200 cfs for 72 hours followed by a daily average flow of 4350 cfs for the remaining four days of the week. Schedule D resulted in an average weekly inflow of 3000 cfs.

21. The fifth test was conducted with the proposed Cooper River redirection weekly hydrograph shown in Table 5 (Schedule E). This hydrograph was similar to Schedule C described in paragraph 19, except that the average weekly flow was increased from 3000 cfs to 3500 cfs. This was accomplished by decreasing the period of zero flow from 72 hours to 69 hours, releasing 28,500 cfs for the following 3-hr period, and

releasing a daily average flow of 5250 cfs for the remaining four days of the week.

22. The sixth test was conducted with the proposed Cooper River redirection weekly hydrograph shown in Table 6 (Schedule BM). It was desired to increase Schedule B's weekly average flow from 3000 cfs to 3500 cfs. This was accomplished by reproducing the same sustained 1325-cfs flow each Sunday but increasing the sustained flow for the remaining six days of the week from 3279 to 3862 cfs.

#### Tides

23. The locations of the 17 tide gage stations are shown in Plate 2. Hourly tidal heights were measured for each station for 14 tidal cycles for the hydrographs of Schedules A, B, C, D, and E. The tidal curves shown in Plates 4-15 are the average curves measured over the 14 cycles at each tide station with the exception of the tidal curves of Schedule BM. The tidal curves for Schedule BM are for a sustained flow of 3500 cfs. This was necessary because of operational problems with the automatic tide gages. Because these problems could not be resolved, it was necessary to use point gages for the Schedule BM tide measurements. Since neither the time nor personnel required were available to make manual tide measurements at all gages throughout the 14-cycle period, it was necessary to simplify the measurement procedure by introducing a constant freshwater inflow. Because the tide measurements for Schedule B did not exhibit marked variations throughout the weekly cycle, this procedure was determined to be a reasonable approximation.

24. The effects of the 3000-cfs redirection hydrographs on the seven-day average of the tidal heights throughout the estuary are shown by comparisons of the existing Schedule A weekly hydrograph and the redirection Schedules B, C, and D. Examination of Plates 4-9 shows little or no change at the downstream Cooper River stations (CR2, CR3, and CR4). The data from the upstream Cooper River stations (CR5, CR6, CR7, and CR8) show progressively more pronounced decreases in water surface elevations due to the reduced flow of Schedules B, C, and D.

The mean water level at CR5 decreased about 0.3 ft, while the levels for CR6, CR7, and CR8 decreased approximately 0.7, 1.2, and 2.0 ft, respectively. Water surface elevations for Stations BR1 and BR2, in Back River Reservoir, were lowered approximately 0.7 ft after rediversion, while the tide range in the reservoir was unchanged. Tide heights after rediversion in the upper end of the East Branch of the Cooper River (EC1) were lowered about 1.4 ft at high water and by varying amounts at low water with the Schedule B test being most pronounced. The Wando River (Stations WR1, WR2, and WR3), the Ashley River (Stations AR1 and AR2), and Clouter Creek (Station CC1) experienced changes which were generally less than 0.3 ft as a result of the reduced flow necessitated by the rediversion.

25. The effects of the 3500-cfs rediversion hydrographs on tidal heights throughout the estuary are shown by comparisons of the existing Schedule A weekly hydrograph and the rediversion Schedules E and BM. Examination of the comparative curves shown in Plates 10-15 shows basically the same effects for Schedules E and BM as were noted and described for Schedules B, C, and D. There was little or no change in the lower portion of the Cooper River, as indicated by measurements at gages CR2, CR3, and CR4. The data from the upstream Cooper River Stations CR5, CR6, CR7, and CR8 show a progressively more pronounced decrease in water surface elevations for both Schedules E and BM of approximately 0.4, 0.8, 1.2, and 2.0 ft, respectively. Water levels at Station EC1 in the upper end of the East Branch of the Cooper River decreased about 1.0 ft after rediversion. Water surface elevations in Back River Reservoir were lowered an average of approximately 0.8 ft for Schedule E and approximately 1.2 ft for Schedule BM. Changes in the Wando River (Stations WR1, WR2, and WR3), the Ashley River (Stations AR1 and AR2), and Clouter Creek (Station CC1) were generally less than 0.4 ft. Differences on the order of about 0.3-0.4 ft exist between the results of Schedules E and BM at a few stations, notably CR4, CR5, WR1, BR1, BR2, and AR1. These differences are probably due to the differences between taking data during reproduction of the Schedule E hydrograph and during a sustained flow which was substituted for Schedule BM as mentioned previously. Therefore, these differences are not considered to be significant.

26. In general, the reduction of the mean Cooper River freshwater discharge from 15,600 cfs to 3000 cfs or 3500 cfs will result in a lowering of the tidal levels throughout the upstream portions of the Cooper River only.

27. Maximum and minimum tide heights at six selected stations (CR5, CR6, CR7, CR8, BR1, and BR2) located either in upper Cooper River or in Back River Reservoir for Schedules A-E are shown in Plates 16-45. Each plate shows the inverted weekly hydrograph (both prototype and model) along with the corresponding water surface levels at the various locations.

28. Plates 16-21 show maximum and minimum tide heights in upper reaches of the estuary throughout a week's operation with Schedule A. In the model, Schedule A had low flows on Sunday (except from 8:00 to 11:00 A.M.) and for the rest of the week had flows varying from 1200 cfs to 26,585 cfs during each day. All six stations showed substantial decreases in high- and low-tide levels all day for Sunday and Monday morning and relative stability throughout the remainder of the week. At Station CR5, the influence of the daily fluctuations of freshwater inflow on the differences between successive high and low waters was quite small. The influence on low-water elevations increased progressively at stations farther upstream, however. At Station CR5, successive low-water elevations differed by about 3.5 ft. Except for the Sunday/Monday morning period, successive high-water elevations at Cooper River stations varied by about 0.2 ft. The Back River stations exhibited the same type of weekly fluctuations; however, elevations of successive high and low waters varied by about 0.5 ft.

29. Plates 22-27 show the maximum and minimum tide heights in upper reaches of the estuary throughout a week's operation with the rediversion Schedule B. In the model, Schedule B had a sustained low flow of 1325 cfs Sunday with a sustained flow of 3250 cfs for the remaining six days of the week. During this relatively stable hydrograph, high-water levels for the six stations remained relatively constant from cycle to cycle, with minor overall fluctuations. Low-water elevations also remained at a fairly constant level during the week with the

greatest overall change, an increase of approximately 0.6 ft, recorded at Station CR8. Tidal ranges and mean tide levels remained relatively constant during the week with Schedule B.

30. The maximum and minimum tide heights in upper reaches of the estuary with Schedule C are shown in Plates 28-33. In the model, Schedule C had zero flow for the first three days of the week followed by a sustained flow of 5250 cfs for the remaining four days. Stations CR5 and CR6 experienced a gradual rise in water surface elevations during the latter part of the week. At Stations CR7 and CR8 a somewhat greater rise occurred, especially at low water, during the 5250-cfs flow. High-water elevations increased about 0.6 ft and 0.4 ft, while low-water elevations increased about 1.1 and 1.3 ft at Stations CR7 and CR8, respectively. Tide ranges were relatively unchanged throughout the week except at Stations CR7 and CR8. The tidal range at Station CR7 decreased from about 3.3 ft on Monday to about 2.9 ft during the latter part of the week, while at Station CR8 the tide range decreased from about 2.5 ft to about 1.6 ft. In Back River Reservoir at Stations BR1 and BR2, a gradual rise in water surface elevation occurred as the week progressed with little or no variation in tidal ranges as shown in Plates 32 and 33.

31. The maximum and minimum tide heights in upper reaches of the estuary with Schedule D are shown in Plates 34-39. In the model, Schedule D had 1200-cfs flow during the three-day period from Sunday through Tuesday with the remaining four days regulated at 4350 cfs. At Station CR5 in Cooper River the Schedule D hydrograph caused minimal change in the water level. A gradual increase in the tide level occurred at Station CR6 during the 4350-cfs flow period, with an associated decrease in tidal range of about 0.2 ft. The increase in water surface elevations was more pronounced at Stations CR7 and CR8, with approximately 0.2- to 0.4-ft-range reductions occurring during the high-flow period of the hydrograph. In Back River Reservoir at Stations BR1 and BR2 a slight, gradual rise in water elevation occurred during the latter part of the week with minimal variation occurring in tide range as is shown in Plates 38 and 39.

32. The maximum and minimum tide heights in upper reaches of the estuary with Schedule E are shown in Plates 40-45. In the model, Schedule E had zero flow during the first 69 hours of the week followed by three hours of 28,500-cfs flow, which is followed by a sustained flow of 5250 cfs for the remaining four days. Maximum and minimum water levels remained fairly constant from Sunday through Tuesday at all locations; then a sharp increase occurred on Wednesday as a result of the 28,500-cfs release during the three-hour period between 9:00 P.M. and 12:00 midnight Tuesday. Subsequently, water levels decreased slightly and remained constant (but significantly higher than Sunday-Tuesday levels) during the remainder of the week. Compared to Sunday-Tuesday levels, low-water peak elevations increased from about 0.3 ft at Station CR5 to about 1.4 ft at Station CR8. Low-water levels during the latter part of the week were increased by amounts varying between about 0.2 ft at Station CR5 to about 1.1 ft at Station CR8 (compared to Sunday-Tuesday levels). High-water levels fluctuated in similar fashion, but the changes were of a lesser magnitude. The tide range was reduced during the week by amounts varying from about 0.3 ft at Station CR5 to about 0.7 ft at Station CR8. Stations BR1 and BR2 in Back River Reservoir were affected in the same manner, with tide levels changing approximately 0.5 ft overall during the week.

#### Current velocities

33. Current measurements were made throughout the estuary for Pinopolis release Schedules A, B, E, and BM and at six selected locations for release Schedules C and D. The current measurements were made during the last tidal cycles of sustained high flow for each hydrograph. Stations utilized for the overall survey included all even-numbered mile stations in Cooper River from mile 0 to mile 44, mile stations 1, 3, 5, 7, 9, and 13 in Wando River, mile stations 1, 3, 5, and 9 in Ashley River, and mile 1 in Clouter Creek. The six selected locations occupied during tests of Schedules C and D were mile 1 in Ashley River and miles 30, 34, 38, 42, and 44 in Cooper River. The locations of all current velocity stations are shown in Plate 3. Measurements were made hourly throughout

a tidal cycle at surface and bottom depths for all conditions tested and the results are presented in Tables 7-46 and in Plates 46-85. The tables also include the times of occurrence and the values of maximum flood and ebb velocities and the computed percentage of the total flow which is in an ebb direction, commonly referred to as ebb predominance. This expression is derived from a conventional plot of velocity versus time over a tidal cycle at any given point. The areas subtended by both ebb and flood portions of the curve are measured (or calculated) and summarized. The area subtended by the ebb portion of the curve is then divided by the total area to determine what percentage of the total flow is in the ebb direction. Predominance values greater than 50 percent indicate that the net flow at the point of measurement is in the downstream or ebb direction. Values less than 50 percent indicate that net flow is in an upstream or flood direction. Plots of surface and bottom flow predominance along Cooper River are presented in Plates 86 and 87, respectively.

34. The effects of redirection of a major portion of the Cooper River freshwater flow on current velocities can be seen by comparing the curves for Schedule A (the existing 15,600-cfs average weekly flow hydrograph) to similar curves for the various redirection release schedules. Schedules B, E, and BM generally increased surface flood velocities upstream of approximately mile 20 in the Cooper River, but caused smaller changes (generally reductions) to surface flood velocities downstream of mile 20 (see Plates 46-68). Throughout Cooper River, surface ebb velocities at over half the measurement locations were relatively unchanged by Schedules B, E, and BM. At the locations where changes in strength of ebb velocities were noted, about half were increases and half were decreases. Schedules B, E, and BM resulted in a significant phase shift of surface velocities upstream of about Cooper River mile 30.

35. Schedules B, E, and BM significantly increased maximum bottom flood velocities upstream of mile 20, while ebb velocities remained relatively unchanged. Maximum bottom ebb velocities were generally increased from the jetties to the mouth of the Cooper River (approximately miles 2 to 14); while above mile 14, ebb velocities in the Cooper

River were generally reduced or unchanged as a result of redirection. Upstream from about mile 30, a significant phase shift of bottom velocities was observed.

36. As seen in Plates 86 and 87, Schedules B, E, and BM resulted in drastic changes of surface and bottom flow predominance in the upstream portion of Cooper River. At the surface, ebb predominances above about mile 28 were reduced from 80-100 percent for Schedule A to 50-80 percent for the redirection schedules. In the vicinity of miles 7-13, surface ebb predominances were reduced from about 65 percent to 50-60 percent. At the bottom, ebb predominances upstream of mile 15 were reduced from about 50-100 percent for Schedule A to about 35-65 percent for the redirection schedules. Between about miles 5 and 15, bottom ebb predominances were increased about 20-50 percent for Schedule A to about 30-60 percent for redirection conditions. It can thus be seen that, for redirection conditions, surface and bottom flow predominance throughout the length of Cooper River would be more nearly balanced for redirection conditions than for existing conditions.

37. In the Wando River, overall effects of the flow reduction to conform to Schedules B, E, or BM appear to be minimal (Tables 30-35). Random increases and decreases in both overall flow and maximum current values occurred. At the three downstream locations measured, miles 1, 3, and 5, bottom ebb flow predominance increased slightly for the redirection schedules.

38. In the Ashley River, the overall effect of the redirection to Schedules B, E, or BM on surface flow also appears to be minimal (Tables 36-39). Surface flow predominance for the four hydrographs tested was in the ebb direction and was generally reduced slightly by the redirection. At bottom depth, random increases and decreases in both flow predominance and maximum current values occurred.

39. The measurements in Clouter Creek show a general reduction in maximum ebb velocities, while the ebb flow predominance was relatively unchanged (Table 40).

40. The effects of Schedules B, C, and D are shown in Tables 41-46 and Plates 80-87. In Cooper River, surface flood velocities were generally increased at the five selected stations, while the surface ebb velocities had slight random increases or decreases as a result of the redirection from Schedule A to Schedules B, C, or D. Maximum bottom flood velocities were increased at these selected stations, while bottom ebb velocities remained generally unchanged or were slightly reduced. Both surface and bottom flow are predominantly ebb, and the redirection significantly reduced ebb predominances at the five Cooper River stations presented (Plates 86 and 87).

41. At mile 3 in the Wando River, surface and bottom maximum ebb velocities were relatively unchanged, while maximum surface and bottom flood velocities decreased slightly due to the redirection from Schedule A to Schedules B, C, or D (Plate 85 and Table 46). Ebb predominances at both surface and bottom depths increased slightly, making the overall flow predominantly in the ebb direction.

#### Salinities

42. Profiles of salinity concentrations in Cooper River for surface and bottom depths, at times of both high- and low-water slack, for the existing Schedule A hydrograph and for the redirection hydrographs, Schedules B, C, D, E, and BM, are shown in Plates 88-93, respectively. The salinity values shown in the six plates were determined by averaging measurements made during Tuesday after the low-flow period of the weekly release hydrograph and measurements made during Saturday after the high-flow period. During the hydrograph week, the salinity front migrated slightly farther upstream and slightly farther downstream than is indicated by the profiles which show the average locations during the week. Considering the capabilities of the model and the limits of accuracy of the salinity measuring equipment and the variability of the background concentrations, the exact location of the 10-ppm value is difficult to define. The location of the 100-ppm value is considered to be accurate; therefore, all discussion of the salinity fronts refers to the location of the 100-ppm values.

43. The upstream limit of intrusion (100 ppm) of ocean salt water (high-water slack, bottom) was at approximately mile 25 for existing or Schedule A conditions. The upstream limit of intrusion of ocean salt water for the 3000-cfs diversion Schedules B and D was at approximately "The Tee," mile 39; while for Schedule C, with zero flow for 72 hours, the salt front moved upstream to approximately mile 40.5. The 3500-cfs diversion Schedules E and BM held the salt front at approximately mile 36, or 3-1/2 miles below "The Tee" and seven miles below the entrance canal to Back River Reservoir. It can also be seen in Plates 88-93 that the diversion schedules significantly reduced the degree of stratification throughout the length of Cooper River. That is, surface and bottom salinities were more nearly identical for diversion conditions than for existing conditions.

44. The salinity profiles in Plates 88-93 have been drawn to show an upstream limit of 10 ppm.

45. Profiles of salinity concentrations in Cooper River for bottom depths, at times of high-water slack, for the six schedules tested are repeated in Plate 94 for direct comparison of the effects of each schedule on the salinity distribution in the Cooper River.

46. Salinities were also measured at seven locations in Ashley River, eight locations in Wando River, one location in Clouter Creek, and two locations each in Back River Reservoir and in the East Branch of the Cooper River. The results of measurements at these locations at high-water slack for the existing Schedule A and the diversion Schedules B, C, D, E, and BM are listed in Table 47, and low-water slack values are listed in Table 48. Salinities in the Ashley River were generally increased on the order of 7 to 12 ppt as a result of the diversion. Salinities in the Wando River were generally increased on the order of 8 to 13 ppt. Salinities in Clouter Creek were also increased on the order of 13 to 17 ppt. Within the accuracy of the salinity measuring system, ocean salt was not detected at the two Back River Reservoir stations or in the lower end of the East Branch of the Cooper River. The degree of stratification in the Ashley and Wando Rivers and Clouter Creek was reduced significantly by the diversion schedules.

#### PART IV: CONCLUSIONS

47. Based on the results of the model tests reported herein, redirection of the Cooper River from an existing weekly average flow of 15,600 cfs to weekly average flows of either 3000 cfs or 3500 cfs had the following effects on tides, currents, and salinities in the Charleston estuary for the existing 35- by 600-ft Cooper River navigation channel:

- a. Tide ranges and levels downstream of mile 20 in Cooper River remained relatively unchanged. Tide levels and ranges in the Wando River and Ashley River were also essentially unchanged. Mean tide levels in the upstream portion of Cooper River were decreased by amounts varying between approximately 0.3 ft at mile 33 to about 2.0 ft at mile 50.5. Mean tide levels in the East Branch of the Cooper River and in Back River Reservoir were decreased approximately 1.0 ft.
- b. Surface flood velocities were generally increased upstream of approximately mile 20 in the Cooper River and were relatively unchanged downstream of mile 20. Surface ebb velocities throughout Cooper River were essentially unchanged. Surface velocities upstream of about mile 30 experienced a significant phase shift.
- c. Maximum bottom flood velocities were significantly increased upstream of about mile 20, while velocities downstream of mile 20 remained relatively unchanged in Cooper River. Maximum bottom ebb velocities were generally increased from about mile 2 to mile 14, while upstream of mile 14 velocities were generally reduced slightly or were unchanged. A significant phase shift of bottom velocities occurred upstream from about mile 36.
- d. Predominance of surface and bottom ebb flow was drastically reduced in the upper reaches of Cooper River. Downstream of the mouth of the Wando River, surface ebb predominance was decreased and bottom ebb predominance was increased. Throughout the length of Cooper River, redirection inflows resulted in more nearly balanced flow predominance at both the surface and bottom.
- e. Changes in flow conditions in Wando River, Ashley River, and Clouter Creek were minimal.

- f. The limit of the average intrusion of ocean salt water (100 ppm) in Cooper River was moved upstream approximately 10 to 15 miles as a result of rediversion. For release schedules averaging 3000 cfs, the weekly average limit of intrusion of salt water was located in the vicinity of "The Tee" between river miles 39 and 40.5. For schedules averaging 3500 cfs, the weekly average limit of intrusion of salt water was located at about mile 36.
- g. The degree of stratification (that is, the difference between surface and bottom salinity) was significantly reduced throughout the length of the Cooper River.
- h. Salt water was not detected in the Back River Reservoir for any of the Pinopolis release schedules tested.
- i. Salinities in the Ashley and Wando Rivers and in Clouter Creek were increased by amounts varying between 4 and 17 ppt. The degree of stratification was also significantly reduced.







TABLE 4

SCHEDULE D  
 PINOPOLIS RELEASES AFTER REDIVERSION  
 1200 cfs for 72 Hours  
 Weekly Average - 3000 cfs

DAYS	SUNDAY		MONDAY		TUESDAY		WEDNESDAY		THURSDAY		FRIDAY		SATURDAY	
	P	M	P	M	P	M	P	M	P	M	P	M	P	M
1 A.M.	1,200	1,200	1,200	1,200	1,200	1,200	1,200	4,350	1,200	4,350	1,200	4,350	1,200	4,350
2 A.M.	1,200	1,200	1,200	1,200	1,200	1,200	1,200	4,350	1,200	4,350	1,200	4,350	1,200	4,350
3 A.M.	1,200	1,200	1,200	1,200	1,200	1,200	1,200	4,350	1,200	4,350	1,200	4,350	1,200	4,350
4 A.M.	1,200	1,200	1,200	1,200	1,200	1,200	1,200	4,350	1,200	4,350	1,200	4,350	1,200	4,350
5 A.M.	1,200	1,200	1,200	1,200	1,200	1,200	1,200	4,350	1,200	4,350	1,200	4,350	1,200	4,350
6 A.M.	1,200	1,200	1,200	1,200	1,200	1,200	1,200	4,350	1,200	4,350	1,200	4,350	1,200	4,350
7 A.M.	1,200	1,200	1,200	1,200	1,200	1,200	1,200	4,350	1,200	4,350	1,200	4,350	1,200	4,350
8 A.M.	1,200	1,200	1,200	1,200	1,200	1,200	3,050	4,350	3,050	4,350	3,050	4,350	3,050	4,350
9 A.M.	1,200	1,200	1,200	1,200	1,200	1,200	6,150	4,350	6,150	4,350	6,150	4,350	6,150	4,350
10 A.M.	1,200	1,200	1,200	1,200	1,200	1,200	6,150	4,350	6,150	4,350	6,150	4,350	6,150	4,350
11 A.M.	1,200	1,200	1,200	1,200	1,200	1,200	6,150	4,350	6,150	4,350	6,150	4,350	6,150	4,350
12 NOON	1,200	1,200	1,200	1,200	1,200	1,200	6,150	4,350	6,150	4,350	6,150	4,350	6,150	4,350
1 P.M.	1,200	1,200	1,200	1,200	1,200	1,200	6,150	4,350	6,150	4,350	6,150	4,350	6,150	4,350
2 P.M.	1,200	1,200	1,200	1,200	1,200	1,200	6,150	4,350	6,150	4,350	6,150	4,350	6,150	4,350
3 P.M.	1,200	1,200	1,200	1,200	1,200	1,200	6,150	4,350	6,150	4,350	6,150	4,350	6,150	4,350
4 P.M.	1,200	1,200	1,200	1,200	1,200	1,200	6,150	4,350	6,150	4,350	6,150	4,350	6,150	4,350
5 P.M.	1,200	1,200	1,200	1,200	1,200	1,200	7,150	4,350	7,150	4,350	7,150	4,350	7,150	4,350
6 P.M.	1,200	1,200	1,200	1,200	1,200	1,200	7,150	4,350	7,150	4,350	7,150	4,350	7,150	4,350
7 P.M.	1,200	1,200	1,200	1,200	1,200	1,200	7,150	4,350	7,150	4,350	7,150	4,350	7,150	4,350
8 P.M.	1,200	1,200	1,200	1,200	1,200	1,200	7,150	4,350	7,150	4,350	7,150	4,350	7,150	4,350
9 P.M.	1,200	1,200	1,200	1,200	1,200	1,200	7,150	4,350	7,150	4,350	7,150	4,350	7,150	4,350
10 P.M.	1,200	1,200	1,200	1,200	1,200	1,200	4,150	4,350	4,150	4,350	4,150	4,350	4,150	4,350
11 P.M.	1,200	1,200	1,200	1,200	1,200	1,200	2,650	4,350	2,650	4,350	2,650	4,350	2,650	4,350
12 P.M.	1,200	1,200	1,200	1,200	1,200	1,200	1,200	4,350	1,200	4,350	1,200	4,350	1,200	4,350
TOTAL	28,800		28,800		28,800		104,400		104,400		104,400		104,400	
DLY. AVG.	1,200		1,200		1,200		4,350		4,350		4,350		4,350	



TABLE 6

SCHEDULE BM  
 PINOPOLIS RELEASES AFTER REDIVERSION  
 WEEKLY AVERAGE - 3500 cfs

Days	Sun	Mon	Tues	Wed	Thurs	Fri	Sat
Hours	M	M	M	M	M	M	M
1 AM	1,325	3,862	3,862	3,862	3,862	3,862	3,862
2 AM	1,325	3,862	3,862	3,862	3,862	3,862	3,862
3 AM	1,325	3,862	3,862	3,862	3,862	3,862	3,862
4 AM	1,325	3,862	3,862	3,862	3,862	3,862	3,862
5 AM	1,325	3,862	3,862	3,862	3,862	3,862	3,862
6 AM	1,325	3,862	3,862	3,862	3,862	3,862	3,862
7 AM	1,325	3,862	3,862	3,862	3,862	3,862	3,862
8 AM	1,325	3,862	3,862	3,862	3,862	3,862	3,862
9 AM	1,325	3,862	3,862	3,862	3,862	3,862	3,862
10 AM	1,325	3,862	3,862	3,862	3,862	3,862	3,862
11 AM	1,325	3,862	3,862	3,862	3,862	3,862	3,862
12 NOON	1,325	3,862	3,862	3,862	3,862	3,862	3,862
1 PM	1,325	3,862	3,862	3,862	3,862	3,862	3,862
2 PM	1,325	3,862	3,862	3,862	3,862	3,862	3,862
3 PM	1,325	3,862	3,862	3,862	3,862	3,862	3,862
4 PM	1,325	3,862	3,862	3,862	3,862	3,862	3,862
5 PM	1,325	3,862	3,862	3,862	3,862	3,862	3,862
6 PM	1,325	3,862	3,862	3,862	3,862	3,862	3,862
7 PM	1,325	3,862	3,862	3,862	3,862	3,862	3,862
8 PM	1,325	3,862	3,862	3,862	3,862	3,862	3,862
9 PM	1,325	3,862	3,862	3,862	3,862	3,862	3,862
10 PM	1,325	3,862	3,862	3,862	3,862	3,862	3,862
11 PM	1,325	3,862	3,862	3,862	3,862	3,862	3,862
12 PM	1,325	3,862	3,862	3,862	3,862	3,862	3,862
TOTAL	31,800	92,700	92,700	92,700	92,700	92,700	92,700
DLY AVG	1,325	3,862	3,862	3,862	3,862	3,862	3,862

**TABLE 7.**  
**CHARLESTON HARBOR MODEL**  
**BUSHY PARK WATER SUPPLY TESTS**  
**CURRENT VELOCITIES FOR PINOPOLIS WEEKLY RELEASE HYDROGRAPHS**  
**SCHEDULES A, B, E, AND BM**  
**COOPER RIVER MILE 00**

TIME IN HOURS	SURFACE			
	SCH A	SCH B	SCH E	SCH B-MOD
0.	-2.3	-2.1	-1.8	-1.7
1.0	-1.9	-2.0	-1.5	-1.6
2.0	-0.3	-1.0	-0.7	-0.8
3.0	-0.6	0.1	-0.4	0.1
4.0	-0.3	0.1	0.1	0.1
5.0	0.1	0.1	0.1	0.1
6.0	0.1	0.1	0.1	0.1
7.0	-0.3	0.1	0.1	0.1
8.0	-0.4	-0.6	-0.5	0.1
9.0	-0.5	-0.8	-0.9	-0.7
10.0	-0.6	-0.8	-0.9	-0.8
11.0	-1.5	-0.9	-1.1	-0.8

TIME IN HOURS	BOTTOM			
	SCH A	SCH B	SCH E	SCH B-MOD
0.	0.1	-0.4	0.1	0.4
1.0	0.1	-0.5	-0.3	0.3
2.0	-0.5	-0.3	-0.7	0.7
3.0	-0.5	-0.3	-0.7	0.3
4.0	-0.3	0.1	-0.7	0.1
5.0	-0.3	0.1	-0.5	0.1
6.0	0.1	0.1	-0.3	0.1
7.0	0.1	0.1	0.1	0.1
8.0	0.1	0.1	0.1	0.1
9.0	-0.3	-0.4	-0.3	0.1
10.0	-0.6	-0.5	-0.5	0.1
11.0	-0.6	-0.5	-0.5	0.5

SCH	SURFACE					
	MAXIMUM FLOOD		MAXIMUM EBB		EBB PRE- DOMINANCE	
	TIME HOURS	VELOCITY DATA	TIME HOURS	VELOCITY DATA		
A	5.0	0.1	0.	2.3	98.1	
B	3.0	0.1	0.	2.1	94.2	
E	4.0	0.1	0.	1.8	94.5	
BM	3.0	0.1	0.	1.7	91.1	

SCH	BOTTOM					
	MAXIMUM FLOOD		MAXIMUM EBB		EBB PRE- DOMINANCE	
	TIME HOURS	VELOCITY DATA	TIME HOURS	VELOCITY DATA		
A	0.	0.1	10.0	-0.6	87.9	
B	4.0	0.1	10.0	-0.5	85.2	
E	0.	0.1	2.0	-0.7	94.9	
BM	2.0	0.7	4.0	0.1	0.	

Note: Time is expressed in hours after moon's transit of 74th meridian.  
 Velocities are expressed in feet per second prototype.

**TABLE 8**  
**CHARLESTON HARBOR MODEL**  
**BUSHY PARK WATER SUPPLY TESTS**  
**CURRENT VELOCITIES FOR PINOPOLIS WEEKLY RELEASE HYDROGRAPHS**  
**SCHEDULES A, B, E, AND BM**  
**COOPER RIVER MILE 02**

TIME IN HOURS	SURFACE			
	SCH A	SCH B	SCH E	SCH B-MOD
0.	-3.0	-3.5	-2.7	-1.9
1.0	-1.9	-2.0	-1.8	-1.2
2.0	-0.3	-0.4	-0.7	-0.4
3.0	0.1	0.3	0.3	0.1
4.0	0.1	0.5	0.7	0.4
5.0	0.3	0.4	0.7	0.5
6.0	0.3	0.3	0.5	0.5
7.0	0.1	0.1	0.3	0.1
8.0	0.1	-0.3	-0.3	-0.3
9.0	-0.9	-1.2	-1.0	-0.9
10.0	-1.5	-2.3	-2.2	-1.7
11.0	-2.3	-3.3	-2.5	-2.4

TIME IN HOURS	BOTTOM			
	SCH A	SCH B	SCH E	SCH B-MOD
0.	-0.3	-1.4	-1.2	-1.2
1.0	-0.6	-1.1	-0.5	-0.5
2.0	-1.0	-0.1	0.5	-0.3
3.0	-0.8	0.3	0.9	0.9
4.0	0.1	0.6	0.9	0.9
5.0	0.5	0.5	0.7	0.7
6.0	0.1	0.2	0.7	0.7
7.0	0.1	0.1	0.4	0.4
8.0	0.1	0.1	0.1	0.1
9.0	-0.3	-0.5	-0.5	-0.5
10.0	-0.5	-1.2	-0.9	-0.9
11.0	-0.5	-1.9	-1.4	-1.4

SCH	SURFACE				EBB PRE- DOMINANCE
	MAXIMUM FLOOD		MAXIMUM EBB		
	TIME HOURS	VELOCITY DATA	TIME HOURS	VELOCITY DATA	
A	5.0	0.3	0.	3.0	91.8
B	4.0	0.5	0.	3.5	90.7
E	4.0	0.7	0.	2.7	83.0
BM	5.0	0.5	11.0	2.4	84.0

SCH	BOTTOM				EBB PRE- DOMINANCE
	MAXIMUM FLOOD		MAXIMUM EBB		
	TIME HOURS	VELOCITY DATA	TIME HOURS	VELOCITY DATA	
A	5.0	0.5	2.0	1.0	82.6
B	4.0	0.6	11.0	1.9	80.5
E	3.0	0.9	11.0	1.6	55.8
BM	3.0	0.9	11.0	1.6	60.3

Note: Time is expressed in hours after moon's transit of 74th meridian.  
 Velocities are expressed in feet per second prototype.

**TABLE 9**  
**CHARLESTON HARBOR MODEL**  
**BUSHY PARK WATER SUPPLY TESTS**  
**CURRENT VELOCITIES FOR PINOPOLIS WEEKLY RELEASE HYDROGRAPHS**  
**SCHEDULES A, B, E, AND BM**  
**COOPER RIVER MILE 04**

TIME IN HOURS	SURFACE			
	SCH A	SCH B	SCH E	SCH B-MOD
0.	-2.8	-3.0	-2.5	-2.1
1.0	-1.2	-1.9	-1.3	-1.3
2.0	0.1	0.5	0.8	-0.4
3.0	1.4	2.0	2.3	1.6
4.0	2.4	2.4	2.6	2.4
5.0	2.0	2.4	2.4	1.9
6.0	1.7	1.7	1.8	1.8
7.0	1.0	1.1	1.2	1.0
8.0	0.1	-0.1	-0.3	-0.6
9.0	-1.5	-1.5	-1.4	-1.3
10.0	-2.2	-2.5	-2.3	-2.1
11.0	-2.9	-3.4	-2.9	-2.3

TIME IN HOURS	BOTTOM			
	SCH A	SCH B	SCH E	SCH B-MOD
0.	-1.3	-1.7	-2.0	-1.7
1.0	-0.3	-0.5	-0.8	-0.7
2.0	1.9	1.1	0.8	0.8
3.0	2.3	2.0	1.5	1.5
4.0	2.1	1.7	1.7	1.6
5.0	1.8	1.8	1.6	1.7
6.0	1.1	1.4	1.6	1.4
7.0	0.8	0.8	0.9	0.9
8.0	0.1	0.1	0.5	0.4
9.0	-0.8	-1.3	-1.2	-1.2
10.0	-1.3	-1.7	-1.8	-1.5
11.0	-1.6	-2.0	-2.0	-1.6

SCH	SURFACE				EBR PRE- DOMINANCE
	MAXIMUM FLOOD		MAXIMUM EBB		
	TIME HOURS	VELOCITY DATA	TIME HOURS	VELOCITY DATA	
A	4.0	2.4	11.0	2.9	57.3
B	4.0	2.4	11.0	3.4	57.7
E	4.0	2.6	11.0	2.9	51.4
BM	4.0	2.4	11.0	2.3	55.6

SCH	BOTTOM				EBR PRE- DOMINANCE
	MAXIMUM FLOOD		MAXIMUM EBB		
	TIME HOURS	VELOCITY DATA	TIME HOURS	VELOCITY DATA	
A	3.0	2.3	11.0	1.6	37.1
B	3.0	2.0	11.0	2.0	47.2
E	4.0	1.7	0.	2.0	49.5
BM	5.0	1.7	0.	1.7	46.3

Note: Time is expressed in hours after moon's transit of 74th meridian.  
 Velocities are expressed in feet per second prototype.

**TABLE 10**  
**CHARLESTON HARBOR MODEL**  
**BUSHY PARK WATER SUPPLY TESTS**  
**CURRENT VELOCITIES FOR PINOPOLIS WEEKLY RELEASE HYDROGRAPHS**  
**SCHEDULES A, B, E, AND BM**  
**COOPER RIVER MILE 06**

TIME IN HOURS	SURFACE			
	SCH A	SCH B	SCH E	SCH B-MOD
0.	-3.0	-2.4	-2.9	-2.9
1.0	-1.9	-0.9	-1.6	-1.5
2.0	0.4	0.1	-1.3	1.4
3.0	1.6	0.9	1.5	1.7
4.0	2.1	1.8	1.9	1.9
5.0	2.0	1.7	1.8	2.0
6.0	1.5	1.5	1.6	1.6
7.0	0.6	0.1	0.8	0.8
8.0	-0.3	-1.6	0.1	0.3
9.0	-2.1	-2.5	-2.1	-2.1
10.0	-3.7	-3.1	-3.5	-3.5
11.0	-4.1	-3.1	-3.8	-4.2

TIME IN HOURS	BOTTOM			
	SCH A	SCH B	SCH E	SCH B-MOD
0.	-1.8	-2.4	-2.3	-2.5
1.0	-0.6	-1.6	-0.8	-0.9
2.0	1.7	0.1	0.1	0.1
3.0	1.9	1.6	1.4	1.6
4.0	2.0	1.6	1.5	1.7
5.0	2.3	1.8	1.5	1.7
6.0	2.0	1.4	1.7	1.9
7.0	1.2	0.9	1.1	1.3
8.0	0.2	0.1	0.1	0.1
9.0	-1.2	-1.6	-1.5	-1.7
10.0	-2.2	-2.6	-3.2	-3.4
11.0	-2.4	-3.1	-3.0	-3.4

SCH	SURFACE				
	MAXIMUM FLOOD		MAXIMUM EBB		EBB PRE- DOMINANCE
	TIME HOURS	VELOCITY DATA	TIME HOURS	VELOCITY DATA	
A	4.0	2.1	11.0	3.1	67.8
B	4.0	1.8	10.0	3.1	76.2
E	4.0	1.9	11.0	3.8	68.6
BM	5.0	2.0	11.0	4.2	62.9

SCH	BOTTOM				
	MAXIMUM FLOOD		MAXIMUM EBB		EBB PRE- DOMINANCE
	TIME HOURS	VELOCITY DATA	TIME HOURS	VELOCITY DATA	
A	5.0	2.3	11.0	2.4	44.6
B	5.0	1.8	11.0	3.1	62.1
E	6.0	1.7	10.0	3.2	61.6
BM	6.0	1.9	10.0	3.6	61.3

Note: Time is expressed in hours after moon's transit of 74th meridian.  
 Velocities are expressed in feet per second prototype.

**TABLE 11**  
**CHARLESTON HARBOR MODEL**  
**BUSHY PARK WATER SUPPLY TESTS**  
**CURRENT VELOCITIES FOR PINOPOLIS WEEKLY RELEASE HYDROGRAPHS**  
**SCHEDULES A, B, E, AND BM**  
**COOPER RIVER MILE 08**

TIME IN HOURS	SURFACE			
	SCH A	SCH B	SCH E	SCH B-MOD
0.	-2.2	-1.4	-1.2	-1.6
1.0	-1.0	-0.6	-0.6	-0.7
2.0	-0.1	0.3	0.1	0.9
3.0	0.8	1.2	1.2	1.1
4.0	1.0	1.7	1.5	1.7
5.0	1.5	1.9	1.6	1.8
6.0	1.0	1.5	1.2	1.4
7.0	0.8	1.2	0.8	1.2
8.0	0.1	0.5	0.1	0.3
9.0	-1.6	-0.8	-0.9	-1.0
10.0	-2.2	-2.0	-2.4	-2.3
11.0	-2.2	-1.9	-1.6	-1.9

TIME IN HOURS	BOTTOM			
	SCH A	SCH B	SCH E	SCH B-MOD
0.	0.1	-1.0	-0.7	-0.9
1.0	-0.3	-0.4	0.1	-0.3
2.0	0.3	0.6	1.1	0.9
3.0	1.9	1.0	1.2	1.2
4.0	1.3	1.1	1.2	1.3
5.0	1.0	0.8	1.2	1.4
6.0	0.9	0.9	1.0	1.0
7.0	0.5	0.7	0.8	0.8
8.0	0.1	0.1	0.1	0.1
9.0	-0.5	-0.7	-0.9	-0.9
10.0	-0.8	-1.7	-1.1	-1.2
11.0	-0.7	-1.4	-1.0	-0.9

SCH	SURFACE				EBB PRE- DOMINANCE
	MAXIMUM FLOOD		MAXIMUM EBB		
	TIME HOURS	VELOCITY DATA	TIME HOURS	VELOCITY DATA	
A	5.0	1.5	0.	2.2	65.0
B	5.0	1.9	10.0	2.0	46.8
E	5.0	1.6	10.0	2.4	52.5
BM	5.0	1.8	10.0	2.3	49.1

SCH	BOTTOM				EBB PRE- DOMINANCE
	MAXIMUM FLOOD		MAXIMUM EBB		
	TIME HOURS	VELOCITY DATA	TIME HOURS	VELOCITY DATA	
A	3.0	1.9	10.0	0.8	29.4
B	4.0	1.1	10.0	1.7	51.4
E	3.0	1.2	10.0	1.1	37.6
BM	5.0	1.4	10.0	1.2	39.3

Note: Time is expressed in hours after moon's transit of 74th meridian.  
 Velocities are expressed in feet per second prototype.

TABLE 12  
 CHARLESTON HARBOR MODEL  
 BUSHY PARK WATER SUPPLY TESTS  
 CURRENT VELOCITIES FOR PINOPOLIS WEEKLY RELEASE HYDROGRAPHS  
 SCHEDULES A, B, E, AND BM  
 COOPER RIVER MILE 10

TIME IN HOURS	SURFACE			
	SCH A	SCH B	SCH E	SCH B-MOD
0.	-2.1	-2.3	-1.8	-2.0
1.0	-1.1	-1.4	-1.4	-1.4
2.0	0.1	0.2	0.1	0.1
3.0	0.6	2.1	1.8	1.7
4.0	1.9	2.4	1.8	2.0
5.0	1.7	1.6	1.4	1.2
6.0	1.6	2.3	0.9	1.1
7.0	0.6	1.2	0.9	0.7
8.0	0.1	0.3	0.1	0.1
9.0	-0.9	-1.5	0.1	-1.3
10.0	-2.4	-2.7	-2.3	-2.3
11.0	-2.8	-3.0	-2.6	-2.6

TIME IN HOURS	BOTTOM			
	SCH A	SCH B	SCH E	SCH B-MOD
0.	-1.2	-1.5	-1.1	-0.9
1.0	0.1	-0.5	-0.5	-0.6
2.0	0.6	0.6	0.1	0.1
3.0	2.4	2.4	1.8	2.3
4.0	2.3	2.3	2.2	2.3
5.0	2.2	2.3	2.0	2.3
6.0	2.1	1.8	1.8	1.7
7.0	1.9	1.7	1.2	1.3
8.0	0.8	0.9	0.1	0.1
9.0	0.1	-0.8	-0.8	-0.8
10.0	-1.0	-2.0	-1.3	-1.5
11.0	-2.3	-1.5	-1.7	-1.6

SCH	SURFACE				EBB PRE- DOMINANCE
	MAXIMUM FLOOD		MAXIMUM EBB		
	TIME HOURS	VELOCITY DATA	TIME HOURS	VELOCITY DATA	
A	4.0	1.9	11.0	-2.8	60.9
B	4.0	2.4	11.0	-3.0	54.6
E	3.0	1.8	11.0	-2.6	56.1
BM	4.0	2.0	11.0	-2.6	60.8

SCH	BOTTOM				EBB PRE- DOMINANCE
	MAXIMUM FLOOD		MAXIMUM EBB		
	TIME HOURS	VELOCITY DATA	TIME HOURS	VELOCITY DATA	
A	3.0	2.4	11.0	-2.3	30.4
B	4.0	2.3	10.0	-2.0	36.3
E	4.0	2.2	11.0	-1.7	39.6
BM	4.0	2.3	10.0	-1.5	37.2

Note: Time is expressed in hours after moon's transit of 74th meridian.  
 Velocities are expressed in feet per second prototype.

**TABLE 13**  
**CHARLESTON HARBOR MODEL**  
**BUSHY PARK WATER SUPPLY TESTS**  
**CURRENT VELOCITIES FOR PINOPOLIS WEEKLY RELEASE HYDROGRAPHS**  
**SCHEDULES A, B, E, AND BM**  
**COOPER RIVER MILE 12**

TIME IN HOURS	SURFACE			
	SCH A	SCH B	SCH E	SCH B-MOD
0.	-0.8	-0.8	-0.9	-1.4
1.0	-0.7	-0.6	-0.9	-1.5
2.0	0.1	-0.4	0.1	-0.8
3.0	0.1	0.3	0.3	1.3
4.0	0.7	1.2	1.3	1.6
5.0	0.5	1.2	0.9	1.5
6.0	0.3	1.6	0.9	1.5
7.0	0.3	1.4	0.8	1.5
8.0	0.1	0.4	0.1	0.3
9.0	-0.3	-1.0	-0.7	-0.8
10.0	-0.7	-1.0	-1.2	-1.4
11.0	-0.6	-1.0	-0.9	-1.5

TIME IN HOURS	BOTTOM			
	SCH A	SCH B	SCH E	SCH B-MOD
0.	-0.4	-0.6	-0.5	-0.7
1.0	-0.4	-0.3	-0.5	-0.5
2.0	0.1	0.4	0.1	0.1
3.0	1.3	1.1	1.0	1.4
4.0	1.9	1.3	1.2	1.5
5.0	1.9	1.3	1.0	1.8
6.0	1.7	1.3	1.0	1.9
7.0	1.6	1.2	0.8	1.2
8.0	0.7	0.8	0.1	0.3
9.0	0.1	-0.3	0.1	-0.8
10.0	-0.4	-0.7	-0.8	-1.0
11.0	-0.3	-0.8	-0.7	-1.0

SCH	SURFACE					
	MAXIMUM FLOOD		MAXIMUM EBB		EBB PRE- DOMINANCE	
	TIME HOURS	VELOCITY DATA	TIME HOURS	VELOCITY DATA		
A	4.0	0.7	0.	10.8	62.9	
B	6.0	1.6	9.0	11.0	44.4	
E	4.0	1.3	10.0	11.2	52.2	
BM	4.0	1.6	1.0	11.5	51.2	

SCH	BOTTOM					
	MAXIMUM FLOOD		MAXIMUM EBB		EBB PRE- DOMINANCE	
	TIME HOURS	VELOCITY DATA	TIME HOURS	VELOCITY DATA		
A	4.0	1.9	0.	10.4	15.5	
B	4.0	1.3	11.0	10.8	29.2	
E	4.0	1.2	10.0	10.8	32.7	
BM	6.0	1.9	10.0	11.0	35.6	

Note: Time is expressed in hours after moon's transit of 74th meridian.  
 Velocities are expressed in feet per second prototype.

**TABLE 14**  
**CHARLESTON HARBOR MODEL**  
**BUSHY PARK WATER SUPPLY TESTS**  
**CURRENT VELOCITIES FOR PINOPOLIS WEEKLY RELEASE HYDROGRAPHS**  
**SCHEDULES A, B, E, AND BM**  
**COOPER RIVER MILE 14**

TIME IN HOURS	SURFACE			
	SCH A	SCH B	SCH E	SCH B-MOD
0.	-3.0	-2.7	-2.9	-2.8
1.0	-2.7	-2.0	-2.6	-2.1
2.0	-0.7	-0.5	-0.9	-1.0
3.0	0.1	0.8	0.7	-0.3
4.0	1.0	1.3	1.1	1.5
5.0	1.6	1.2	1.1	0.9
6.0	2.3	1.0	1.4	0.9
7.0	0.8	0.7	0.7	0.9
8.0	0.4	0.5	0.5	0.2
9.0	0.1	-0.8	-0.9	-0.9
10.0	-3.2	-2.7	-1.8	-1.6
11.0	-3.6	-3.2	-2.7	-2.6

TIME IN HOURS	BOTTOM			
	SCH A	SCH B	SCH E	SCH B-MOD
0.	-2.3	-2.7	-2.1	-1.6
1.0	-0.8	-2.0	-0.5	-0.5
2.0	0.1	-0.8	0.3	-0.5
3.0	0.8	0.8	1.8	1.4
4.0	1.3	1.3	1.7	1.6
5.0	1.6	1.3	1.6	1.6
6.0	1.9	1.1	1.5	1.6
7.0	1.6	0.6	1.4	1.6
8.0	0.7	0.4	1.0	0.9
9.0	0.1	-0.7	-0.3	0.1
10.0	-1.5	-2.6	-2.1	-1.7
11.0	-2.4	-3.2	-2.9	-2.4

SCH	SURFACE					
	TIME HOURS	MAXIMUM FLOOD		MAXIMUM EBB		EBB PRE- DOMINANCE
		VELOCITY DATA	TIME HOURS	VELOCITY DATA	TIME HOURS	
A	6.0	2.3	11.0	-3.6	69.9	
B	4.0	1.3	11.0	-3.2	70.7	
E	6.0	1.4	0.	-2.9	70.9	
BM	4.0	1.5	0.	-2.8	74.8	

SCH	BOTTOM					
	TIME HOURS	MAXIMUM FLOOD		MAXIMUM EBB		EBB PRE- DOMINANCE
		VELOCITY DATA	TIME HOURS	VELOCITY DATA	TIME HOURS	
A	6.0	1.9	11.0	-2.4	49.5	
B	4.0	1.3	11.0	-3.2	71.4	
E	3.0	1.8	11.0	-2.9	49.7	
BM	4.0	1.6	11.0	-2.4	45.9	

Note: Time is expressed in hours after moon's transit of 74th meridian.  
 Velocities are expressed in feet per second prototype.

TABLE 15  
 CHARLESTON HARBOR MODEL  
 BUSHY PARK WATER SUPPLY TESTS  
 CURRENT VELOCITIES FOR PINOPOLIS WEEKLY RELEASE HYDROGRAPHS  
 SCHEDULES A, B, E, AND BM  
 COOPER RIVER MILE 16

TIME IN HOURS	SURFACE			
	SCH A	SCH B	SCH E	SCH B-MOD
0.	-3.6	-2.7	-3.6	-3.0
1.0	-2.9	-2.6	-3.0	-2.5
2.0	-1.5	-1.1	-0.8	-0.9
3.0	0.5	0.5	0.1	0.3
4.0	0.3	0.8	0.6	0.9
5.0	0.6	1.0	1.0	1.6
6.0	0.7	0.8	1.2	0.8
7.0	0.3	0.5	0.3	0.4
8.0	-0.3	0.3	0.1	0.3
9.0	-1.8	-0.5	-0.5	-0.6
10.0	-3.4	-3.3	-2.3	-2.6
11.0	-3.6	-4.0	-3.8	-3.0

TIME IN HOURS	BOTTOM			
	SCH A	SCH B	SCH E	SCH B-MOD
0.	-1.7	-1.1	-1.5	-1.4
1.0	-1.5	-0.9	-1.0	-1.1
2.0	-1.0	-0.5	-0.6	-0.3
3.0	0.8	1.2	0.1	2.0
4.0	1.5	1.9	1.5	2.5
5.0	1.7	1.7	1.6	2.1
6.0	1.6	1.7	1.3	2.1
7.0	1.4	1.5	1.2	1.9
8.0	1.0	1.0	0.8	1.4
9.0	-0.3	0.1	0.1	0.3
10.0	-1.7	-0.8	-1.3	-1.2
11.0	-2.4	-0.9	-1.3	-1.6

SCH	SURFACE				EBB PRE- DOMINANCE
	MAXIMUM FLOOD		MAXIMUM EBB		
	TIME HOURS	VELOCITY DATA	TIME HOURS	VELOCITY DATA	
A	6.0	0.7	0.	3.6	88.6
B	5.0	1.0	11.0	4.0	80.3
E	6.0	1.2	11.0	3.8	82.3
BM	5.0	1.6	0.	3.0	76.8

SCH	BOTTOM				EBB PRE- DOMINANCE
	MAXIMUM FLOOD		MAXIMUM EBB		
	TIME HOURS	VELOCITY DATA	TIME HOURS	VELOCITY DATA	
A	5.0	1.7	11.0	2.4	55.8
B	4.0	1.9	0.	1.1	33.2
E	5.0	1.6	0.	1.5	47.9
BM	4.0	2.5	11.0	1.6	33.8

Note: Time is expressed in hours after moon's transit of 74th meridian.  
 Velocities are expressed in feet per second prototype.

**TABLE 16**  
**CHARLESTON HARBOR MODEL**  
**BUSHY PARK WATER SUPPLY TESTS**  
**CURRENT VELOCITIES FOR PINOPOLIS WEEKLY RELEASE HYDROGRAPHS**  
**SCHEDULES A, B, E, AND BM**  
**COOPER RIVER MILE 18**

TIME IN HOURS	SURFACE			
	SCH A	SCH B	SCH E	SCH B-MOD
0.	-2.3	-2.1	-2.4	-2.1
1.0	-1.7	-1.7	-2.1	-2.0
2.0	-1.0	-0.6	-1.1	-1.0
3.0	0.5	0.3	0.3	0.4
4.0	0.6	0.6	0.9	0.6
5.0	0.6	0.8	1.2	0.7
6.0	0.9	0.6	0.7	0.4
7.0	0.5	0.6	0.7	0.6
8.0	0.3	0.5	0.4	0.3
9.0	-0.6	-0.3	-0.4	-0.5
10.0	-1.9	-2.1	-2.1	-1.8
11.0	-2.1	-2.1	-2.4	-2.2

TIME IN HOURS	BOTTOM			
	SCH A	SCH B	SCH E	SCH B-MOD
0.	-2.2	-1.3	-1.9	-1.2
1.0	-2.1	-1.2	-1.4	-1.0
2.0	-1.0	0.1	-0.4	0.1
3.0	0.5	1.9	1.9	1.9
4.0	0.6	1.9	2.1	1.8
5.0	0.7	1.5	2.1	2.0
6.0	1.7	1.5	2.1	2.0
7.0	1.8	0.5	1.9	1.8
8.0	1.3	0.9	1.3	1.6
9.0	-0.5	0.1	-0.5	0.3
10.0	-0.8	-1.1	-1.4	-0.9
11.0	-1.6	-1.3	-2.0	-1.2

SCH	SURFACE					
	MAXIMUM FLOOD			MAXIMUM EBB		
	TIME HOURS	VELOCITY DATA	TIME HOURS	VELOCITY DATA	EBB PRE- DOMINANCE	
A	6.0	0.9	0.	2.3	75.3	
B	5.0	0.8	0.	2.1	73.5	
E	5.0	1.2	0.	2.4	73.2	
BM	5.0	0.7	11.0	2.2	78.4	

SCH	BOTTOM					
	MAXIMUM FLOOD			MAXIMUM EBB		
	TIME HOURS	VELOCITY DATA	TIME HOURS	VELOCITY DATA	EBB PRE- DOMINANCE	
A	7.0	1.8	0.	2.2	58.0	
B	3.0	1.9	0.	1.3	39.8	
E	4.0	2.1	11.0	2.0	42.7	
BM	5.0	2.0	0.	1.2	29.9	

Note: Time is expressed in hours after moon's transit of 74th meridian.  
 Velocities are expressed in feet per second prototype.

**TABLE 17**  
**CHARLESTON HARBOR MODEL**  
**BUSHY PARK WATER SUPPLY TESTS**  
**CURRENT VELOCITIES FOR PINOPOLIS WEEKLY RELEASE HYDROGRAPHS**  
**SCHEDULES A, B, E, AND BM**  
**COOPER RIVER MILE 20**

TIME IN HOURS	SURFACE			
	SCH A	SCH B	SCH E	SCH B-MOD
0.	-1.9	-2.2	-1.9	-2.3
1.0	-1.7	-1.9	-1.8	-2.3
2.0	-0.9	-0.8	-1.0	-1.5
3.0	0.5	0.5	0.1	0.1
4.0	1.1	0.7	1.2	0.8
5.0	1.2	0.9	1.3	0.9
6.0	1.4	1.2	1.2	1.0
7.0	1.1	1.1	1.1	0.8
8.0	0.7	0.7	0.5	0.3
9.0	-0.4	-0.3	0.1	0.1
10.0	-1.6	-1.4	-1.6	-1.6
11.0	-1.8	-1.6	-1.8	-1.6

TIME IN HOURS	BOTTOM			
	SCH A	SCH B	SCH E	SCH B-MOD
0.	-1.1	-1.3	-1.4	-1.5
1.0	-0.7	-1.2	-1.3	-1.4
2.0	-0.5	-0.6	-0.5	-0.7
3.0	0.5	1.1	0.1	0.1
4.0	1.3	1.7	1.3	1.0
5.0	1.5	1.7	1.6	1.0
6.0	1.5	1.4	1.0	0.9
7.0	1.5	1.4	1.0	1.0
8.0	1.1	1.1	0.9	0.8
9.0	-0.5	0.2	0.1	0.1
10.0	-0.9	-0.8	-0.9	-0.5
11.0	-1.2	-1.5	-1.2	-0.8

SCH	SURFACE					
	MAXIMUM FLOOD			MAXIMUM EBB		
	TIME HOURS	VELOCITY DATA	TIME HOURS	VELOCITY DATA	EBB PRE- DOMINANCE	
A	6.0	1.4	0.	-1.9	60.0	
B	6.0	1.2	0.	-2.2	62.3	
E	5.0	1.3	0.	-1.9	61.3	
BM	6.0	1.0	0.	-2.3	71.6	

SCH	BOTTOM					
	MAXIMUM FLOOD			MAXIMUM EBB		
	TIME HOURS	VELOCITY DATA	TIME HOURS	VELOCITY DATA	EBB PRE- DOMINANCE	
A	5.0	1.5	11.0	11.2	42.3	
B	4.0	1.7	11.0	11.5	41.3	
E	5.0	1.6	0.	11.4	49.3	
BM	4.0	1.0	0.	11.5	52.3	

Note: Time is expressed in hours after moon's transit of 74th meridian.  
 Velocities are expressed in feet per second prototype.

TABLE 18  
 CHARLESTON HARBOR MODEL  
 BUSHY PARK WATER SUPPLY TESTS  
 CURRENT VELOCITIES FOR PINOPOLIS WEEKLY RELEASE HYDROGRAPHS  
 SCHEDULES A, B, E, AND BM  
 COOPER RIVER MILE 22

TIME IN HOURS	SURFACE			
	SCH A	SCH B	SCH E	SCH B-MOD
0.	-0.9	-1.6	-1.2	-1.4
1.0	-1.4	-1.3	-1.1	-1.1
2.0	-0.8	-0.7	-0.5	-0.8
3.0	0.1	0.1	0.1	0.1
4.0	0.6	0.9	0.8	0.8
5.0	0.5	0.7	0.5	0.8
6.0	0.3	1.2	0.5	1.1
7.0	0.3	0.8	0.5	0.9
8.0	0.2	0.5	0.3	0.8
9.0	0.1	0.1	0.1	0.1
10.0	-0.8	-0.9	-1.4	-1.5
11.0	-1.5	-1.5	-1.9	-2.0

TIME IN HOURS	BOTTOM			
	SCH A	SCH B	SCH E	SCH B-MOD
0.	-1.5	-0.9	-0.6	-0.5
1.0	-1.5	-1.5	-0.7	-0.6
2.0	-1.2	-0.9	-0.6	-0.3
3.0	0.1	0.1	0.1	0.1
4.0	0.6	0.9	0.5	0.9
5.0	0.6	0.9	0.7	1.0
6.0	0.6	1.0	0.7	1.4
7.0	0.6	1.2	0.7	1.4
8.0	0.5	0.6	0.5	1.1
9.0	0.1	0.1	0.5	0.3
10.0	-0.7	-0.3	0.1	0.1
11.0	-1.5	-1.1	-0.9	-0.5

SCH	SURFACE					
	MAXIMUM FLOOD		MAXIMUM EBB		EBB PRE- DOMINANCE	
	TIME HOURS	VELOCITY DATA	TIME HOURS	VELOCITY DATA		
A	4.0	0.6	11.0	-1.5	75.8	
B	6.0	1.2	0.	-1.6	60.1	
E	4.0	0.8	11.0	-1.9	71.8	
BM	6.0	1.1	11.0	-2.0	62.8	

SCH	BOTTOM					
	MAXIMUM FLOOD		MAXIMUM EBB		EBB PRE- DOMINANCE	
	TIME HOURS	VELOCITY DATA	TIME HOURS	VELOCITY DATA		
A	4.0	0.6	0.	-1.5	69.6	
B	7.0	1.2	1.0	-1.5	52.3	
E	5.0	0.7	11.0	-0.9	46.4	
BM	6.0	1.4	1.0	-0.6	24.5	

Note: Time is expressed in hours after moon's transit of 74th meridian.  
 Velocities are expressed in feet per second prototype.

**TABLE 19**  
**CHARLESTON HARBOR MODEL**  
**BUSHY PARK WATER SUPPLY TESTS**  
**CURRENT VELOCITIES FOR PINOPOLIS WEEKLY RELEASE HYDROGRAPHS**  
**SCHEDULES A, B, E, AND BM**  
**COOPER RIVER MILE 24**

TIME IN HOURS	SURFACE			SCH
	SCH A	SCH B	SCH E	B-MOD
0.	-3.2	-3.2	-4.2	-3.1
1.0	-3.8	-3.0	-4.0	-2.8
2.0	-3.3	-2.7	-3.2	-1.7
3.0	1.2	-0.6	-0.7	0.6
4.0	1.4	1.1	1.2	1.4
5.0	-1.2	1.6	1.8	1.6
6.0	1.2	1.4	1.7	1.6
7.0	1.5	1.6	1.6	1.7
8.0	1.2	1.4	1.3	1.2
9.0	-1.5	0.3	0.3	-0.1
10.0	-1.8	-1.6	-1.9	-1.9
11.0	-2.9	-2.8	-3.4	-3.1

TIME IN HOURS	BOTTOM			SCH
	SCH A	SCH B	SCH E	B-MOD
0.	-2.9	-2.6	-2.9	-2.9
1.0	-3.0	-2.3	-2.5	-2.8
2.0	-2.7	-1.5	-1.3	-1.5
3.0	-1.2	0.8	0.8	0.6
4.0	0.8	1.4	1.3	1.3
5.0	0.9	1.3	1.3	1.6
6.0	1.0	1.6	1.4	1.6
7.0	1.0	1.8	1.4	1.5
8.0	0.9	1.3	1.1	1.3
9.0	-0.6	0.3	-0.1	0.5
10.0	-1.9	-1.4	-1.6	-1.3
11.0	-2.8	-2.4	-2.4	-2.4

SCH	SURFACE					
	MAXIMUM FLOOD		MAXIMUM EBB		EBB PRE- DOMINANCE	
	TIME HOURS	VELOCITY DATA	TIME HOURS	VELOCITY DATA		
A	7.0	1.5	1.0	3.8	70.7	
B	5.0	1.6	0.	3.2	66.2	
E	5.0	1.8	0.	4.2	70.9	
BM	7.0	1.7	0.	3.1	63.4	

SCH	BOTTOM					
	MAXIMUM FLOOD		MAXIMUM EBB		EBB PRE- DOMINANCE	
	TIME HOURS	VELOCITY DATA	TIME HOURS	VELOCITY DATA		
A	6.0	1.0	1.0	3.0	78.6	
B	7.0	1.8	0.	2.6	57.6	
E	6.0	1.4	0.	2.9	62.4	
BM	5.0	1.6	0.	2.9	59.8	

Note: Time is expressed in hours after moon's transit of 74th meridian.  
 Velocities are expressed in feet per second prototype.

TABLE 20  
 CHARLESTON HARBOR MODEL  
 BUSHY PARK WATER SUPPLY TESTS  
 CURRENT VELOCITIES FOR PINOPOLIS WEEKLY RELEASE HYDROGRAPHS  
 SCHEDULES A, B, E, AND BM  
 COOPER RIVER MILE 26

TIME IN HOURS	SURFACE			
	SCH A	SCH B	SCH E	SCH B-MOD
0.	-0.9	-1.0	-1.7	-0.9
1.0	-0.8	-0.9	-1.7	-0.8
2.0	-0.5	-1.2	-1.5	-0.9
3.0	0.1	-0.4	-0.6	0.1
4.0	0.2	0.6	0.6	0.4
5.0	0.5	0.8	0.8	0.9
6.0	0.7	0.9	0.9	0.5
7.0	0.5	1.2	1.2	0.1
8.0	0.5	0.8	0.8	0.1
9.0	0.1	0.2	0.1	0.1
10.0	-0.8	-0.3	-0.5	-0.7
11.0	-1.0	-0.5	-0.8	-0.6

TIME IN HOURS	BOTTOM			
	SCH A	SCH B	SCH E	SCH B-MOD
0.	-1.9	-1.5	-1.5	-1.5
1.0	-1.7	-1.9	-1.9	-1.1
2.0	-1.6	-1.4	-1.4	-0.7
3.0	-0.8	-0.3	-0.3	0.1
4.0	0.1	0.7	0.7	0.7
5.0	0.1	0.9	0.9	1.1
6.0	0.3	1.1	1.1	0.9
7.0	0.4	1.2	1.2	0.9
8.0	0.3	1.2	1.2	0.7
9.0	0.1	0.6	0.6	0.3
10.0	-0.4	0.1	0.1	0.1
11.0	-1.0	-0.4	-0.4	-0.9

SCH	SURFACE				EBB PRE- DOMINANCE
	MAXIMUM FLOOD		MAXIMUM EBB		
	TIME HOURS	VELOCITY DATA	TIME HOURS	VELOCITY DATA	
A	6.0	0.7	11.0	-1.0	61.4
B	7.0	1.2	2.0	-1.2	49.8
E	7.0	1.2	0.	-1.7	62.8
BM	5.0	0.9	0.	-0.9	64.3

SCH	BOTTOM				EBB PRE- DOMINANCE
	MAXIMUM FLOOD		MAXIMUM EBB		
	TIME HOURS	VELOCITY DATA	TIME HOURS	VELOCITY DATA	
A	7.0	0.4	0.	-1.9	86.8
B	7.0	1.2	1.0	-1.9	50.8
E	7.0	1.2	1.0	-1.9	50.8
BM	5.0	1.1	0.	-1.5	49.8

Note: Time is expressed in hours after moon's transit of 74th meridian.  
 Velocities are expressed in feet per second prototype.

**TABLE 21**  
**CHARLESTON HARBOR MODEL**  
**BUSHY PARK WATER SUPPLY TESTS**  
**CURRENT VELOCITIES FOR PINOPOLIS WEEKLY RELEASE HYDROGRAPHS**  
**SCHEDULES A, B, E, AND BM**  
**COOPER RIVER MILE 28**

TIME IN HOURS	SURFACE			SCH
	SCH A	SCH B	SCH E	B-MOD
0.	-1.2	-2.2	-1.5	-1.6
1.0	-1.3	-1.7	-1.2	-1.4
2.0	-1.0	-1.6	-1.0	-0.8
3.0	-0.3	-0.7	-0.5	-0.4
4.0	0.1	0.1	0.1	0.5
5.0	0.2	0.7	0.3	0.2
6.0	0.4	1.3	0.2	0.7
7.0	0.3	1.6	0.2	0.1
8.0	0.4	1.2	0.2	0.2
9.0	0.1	0.7	0.1	0.1
10.0	-0.5	-0.6	-0.1	-0.8
11.0	-0.8	-1.1	-0.9	-1.0

TIME IN HOURS	BOTTOM			SCH
	SCH A	SCH B	SCH E	B-MOD
0.	-1.3	-1.0	-0.9	-1.2
1.0	-1.4	-1.1	-0.9	-1.2
2.0	-1.3	-0.9	-0.8	-0.8
3.0	-0.8	-0.1	-0.3	-0.3
4.0	-0.3	0.6	0.1	0.5
5.0	0.1	1.3	0.9	1.0
6.0	0.2	1.2	1.4	1.4
7.0	0.5	1.3	1.5	1.6
8.0	0.4	1.5	1.5	1.6
9.0	0.1	0.9	0.9	1.2
10.0	-0.5	0.1	0.1	0.1
11.0	-1.1	-0.4	-0.5	-0.7

SCH	SURFACE				EBB PRE- DOMINANCE
	MAXIMUM FLOOD		MAXIMUM EBB		
	TIME HOURS	VELOCITY DATA	TIME HOURS	VELOCITY DATA	
A	6.0	0.4	1.0	1.3	79.1
B	7.0	1.6	0.	2.2	60.8
E	5.0	0.3	0.	1.5	83.4
BM	6.0	0.7	0.	1.6	77.3

SCH	BOTTOM				EBB PRE- DOMINANCE
	MAXIMUM FLOOD		MAXIMUM EBB		
	TIME HOURS	VELOCITY DATA	TIME HOURS	VELOCITY DATA	
A	7.0	0.5	1.0	1.4	85.7
B	8.0	1.5	1.0	1.1	35.0
E	7.0	1.5	0.	0.9	37.0
BM	7.0	1.6	0.	1.2	38.6

Note: Time is expressed in hours after moon's transit of 74th meridian.  
 Velocities are expressed in feet per second prototype.

**TABLE 22**  
**CHARLESTON HARBOR MODEL**  
**BUSHY PARK WATER SUPPLY TESTS**  
**CURRENT VELOCITIES FOR PINOPOLIS WEEKLY RELEASE HYDROGRAPHS**  
**SCHEDULES A, B, E, AND BM**  
**COOPER RIVER MILE 30**

TIME IN HOURS	SURFACE			
	SCH A	SCH B	SCH E	SCH B-MOD
0.	-2.5	-1.7	-1.9	-1.2
1.0	-2.6	-2.0	-2.1	-2.4
2.0	-2.3	-1.9	-1.8	-2.4
3.0	-1.4	-0.6	-0.5	-0.6
4.0	-0.3	0.2	0.1	0.1
5.0	0.1	0.7	0.8	1.1
6.0	0.3	0.6	1.0	1.2
7.0	0.4	0.4	1.1	1.0
8.0	0.2	0.3	0.9	0.9
9.0	0.1	0.1	0.7	0.6
10.0	-0.3	-0.3	0.1	0.1
11.0	-1.5	-1.0	-1.1	-0.8

TIME IN HOURS	BOTTOM			
	SCH A	SCH B	SCH E	SCH B-MOD
0.	-2.1	-2.3	-1.5	-1.6
1.0	-2.3	-2.3	-1.7	-1.7
2.0	-2.4	-2.3	-1.5	-1.6
3.0	-2.0	-1.5	-0.7	-0.8
4.0	-0.6	0.1	0.3	0.1
5.0	0.1	0.6	1.1	0.7
6.0	0.1	1.3	1.1	1.2
7.0	0.1	1.3	1.5	1.4
8.0	0.3	0.8	1.3	1.1
9.0	0.1	0.6	1.1	0.9
10.0	-0.7	0.3	0.2	0.1
11.0	-1.6	-0.5	-0.7	-0.9

SCH	SURFACE				
	MAXIMUM FLOOD		MAXIMUM EBB		EBB PRE- DOMINANCE
	TIME HOURS	VELOCITY DATA	TIME HOURS	VELOCITY DATA	
A	7.0	0.4	1.0	2.6	92.8
B	5.0	0.7	1.0	2.0	77.9
E	7.0	1.1	1.0	2.1	63.5
BM	6.0	1.2	1.0	2.4	61.8

SCH	BOTTOM				
	MAXIMUM FLOOD		MAXIMUM EBB		EBB PRE- DOMINANCE
	TIME HOURS	VELOCITY DATA	TIME HOURS	VELOCITY DATA	
A	8.0	0.3	2.0	2.4	94.9
B	6.0	1.3	1.0	2.3	64.7
E	7.0	1.5	1.0	1.7	49.8
BM	7.0	1.4	1.0	1.7	56.4

Note: Time is expressed in hours after moon's transit of 74th meridian.  
 Velocities are expressed in feet per second prototype.

**TABLE 23**  
**CHARLESTON HARBOR MODEL**  
**BUSHY PARK WATER SUPPLY TESTS**  
**CURRENT VELOCITIES FOR PINOPOLIS WEEKLY RELEASE HYDROGRAPHS**  
**SCHEDULES A, B, E, AND BM**  
**COOPER RIVER MILE 32**

TIME IN HOURS	SURFACE			
	SCH A	SCH B	SCH E	SCH B-MOD
0.	-3.2	-2.7	-2.6	-2.9
1.0	-3.4	-2.8	-2.7	-3.0
2.0	-3.6	-3.2	-3.0	-2.8
3.0	-2.9	-1.3	-1.4	-1.3
4.0	-0.9	0.1	0.1	-0.6
5.0	-0.3	1.3	0.9	1.5
6.0	0.1	1.4	1.6	1.5
7.0	0.3	1.3	1.6	1.6
8.0	0.7	1.1	1.6	1.6
9.0	0.3	0.9	0.9	0.9
10.0	-0.5	0.1	0.3	0.3
11.0	-2.7	-1.8	0.1	-1.8

TIME IN HOURS	BOTTOM			
	SCH A	SCH B	SCH E	SCH B-MOD
0.	-2.6	-2.4	-3.0	-3.3
1.0	-2.8	-2.6	-3.0	-3.6
2.0	-2.7	-2.6	-3.0	-3.6
3.0	-2.2	-0.9	-1.6	-2.1
4.0	-1.1	0.1	0.1	-0.4
5.0	-0.3	1.5	1.2	1.3
6.0	0.1	1.5	1.6	2.1
7.0	0.5	1.7	1.6	2.1
8.0	0.7	2.1	1.6	2.1
9.0	0.4	1.0	1.2	1.4
10.0	0.1	0.1	0.1	0.3
11.0	-2.0	-0.9	-1.8	-1.9

SCH	SURFACE				EBR PRE- DOMINANCE
	MAXIMUM FLOOD		MAXIMUM EBB		
	TIME HOURS	VELOCITY DATA	TIME HOURS	VELOCITY DATA	
A	8.0	0.7	2.0	-3.6	93.1
B	6.0	1.4	2.0	-3.2	67.3
E	6.0	1.6	2.0	-3.0	58.0
BM	7.0	1.6	1.0	-3.0	65.0

SCH	BOTTOM				EBR PRE- DOMINANCE
	MAXIMUM FLOOD		MAXIMUM EBB		
	TIME HOURS	VELOCITY DATA	TIME HOURS	VELOCITY DATA	
A	8.0	0.7	1.0	2.8	88.8
B	8.0	2.1	1.0	2.6	53.9
E	6.0	1.6	0.	-3.0	64.0
BM	6.0	2.1	1.0	3.6	63.6

Note: Time is expressed in hours after moon's transit of 74th meridian.  
 Velocities are expressed in feet per second prototype.

TABLE 24  
 CHARLESTON HARBOR MODEL  
 BUSHY PARK WATER SUPPLY TESTS  
 CURRENT VELOCITIES FOR PINOPOLIS WEEKLY RELEASE HYDROGRAPHS  
 SCHEDULES A, B, E, AND BM  
 COOPER RIVER MILE 34

TIME IN HOURS	SURFACE			SCH
	SCH A	SCH B	SCH E	B-NOD
0.	-0.5	-1.3	-0.9	-0.8
1.0	-0.5	-1.3	-1.0	-0.7
2.0	-0.5	-1.5	-0.9	-1.4
3.0	-0.4	-0.9	-0.9	-0.1
4.0	0.1	0.1	0.1	0.1
5.0	0.1	1.1	0.1	0.5
6.0	0.1	0.8	0.1	1.2
7.0	0.1	0.5	0.1	1.8
8.0	0.1	0.5	0.1	1.7
9.0	0.1	0.5	0.1	1.5
10.0	0.1	-0.1	0.1	0.4
11.0	-0.3	-0.8	0.1	0.1

TIME IN HOURS	BOTTOM			SCH
	SCH A	SCH B	SCH E	B-NOD
0.	-0.8	-0.8	-0.7	-0.5
1.0	-1.0	-1.0	-0.9	-0.5
2.0	-0.8	-0.8	-0.9	-0.6
3.0	-0.3	-0.5	-0.6	-0.5
4.0	0.1	0.1	0.1	0.1
5.0	0.1	0.8	0.1	0.4
6.0	0.1	1.4	0.3	0.8
7.0	0.1	1.5	0.5	1.5
8.0	0.1	1.4	0.9	1.3
9.0	0.1	1.3	0.9	1.0
10.0	0.1	0.7	0.5	0.5
11.0	-0.8	-0.5	0.1	-0.2

SCH	SURFACE				EBB PRE- DOMINANCE
	MAXIMUM FLOOD		MAXIMUM EBB		
	TIME HOURS	VELOCITY DATA	TIME HOURS	VELOCITY DATA	
A	4.0	0.1	0.	0.5	84.6
B	5.0	1.1	2.0	1.5	64.2
E	4.0	0.1	1.0	1.0	77.6
BM	7.0	1.8	2.0	1.4	29.2

SCH	BOTTOM				EBB PRE- DOMINANCE
	MAXIMUM FLOOD		MAXIMUM EBB		
	TIME HOURS	VELOCITY DATA	TIME HOURS	VELOCITY DATA	
A	4.0	0.1	1.0	1.0	90.3
B	7.0	1.5	1.0	1.0	39.2
E	8.0	0.9	1.0	0.9	46.8
BM	7.0	1.5	2.0	0.6	30.3

Note: Time is expressed in hours after moon's transit of 74th meridian.  
 Velocities are expressed in feet per second prototype.

**TABLE 25**  
**CHARLESTON HARBOR MODEL**  
**BUSHY PARK WATER SUPPLY TESTS**  
**CURRENT VELOCITIES FOR PINOPOLIS WEEKLY RELEASE HYDROGRAPHS**  
**SCHEDULES A, B, E, AND BM**  
**COOPER RIVER MILE 36**

TIME IN HOURS	SURFACE			SCH
	SCH A	SCH B	SCH E	B-MOD
0.	-1.2	-1.4	-1.6	-1.5
1.0	-1.4	-1.6	-1.7	-1.6
2.0	-1.6	-1.8	-1.6	-1.6
3.0	-1.5	-1.5	-1.0	-1.1
4.0	-0.7	0.1	0.1	-0.3
5.0	-0.3	1.0	0.3	0.5
6.0	0.1	1.0	0.5	1.0
7.0	0.1	1.6	0.6	1.6
8.0	0.1	2.1	1.6	1.7
9.0	0.1	1.6	1.8	2.0
10.0	0.1	0.7	0.8	-1.0
11.0	-0.6	-0.3	0.1	-1.0

TIME IN HOURS	BOTTOM			SCH
	SCH A	SCH B	SCH E	B-MOD
0.	-0.8	-0.6	-0.9	-1.0
1.0	-1.2	-0.6	-0.6	-0.9
2.0	-1.2	-0.7	-0.9	-1.0
3.0	-0.8	-0.5	-0.7	-0.6
4.0	-0.3	0.1	0.1	0.1
5.0	0.1	0.2	0.1	0.3
6.0	0.1	0.3	0.1	0.5
7.0	0.1	0.2	0.6	0.5
8.0	0.1	0.2	0.9	0.5
9.0	0.1	0.2	0.7	0.3
10.0	-0.3	0.2	0.4	0.1
11.0	-0.6	-0.4	0.1	-0.5

SCH	SURFACE				EBB PRE- DOMINANCE
	MAXIMUM FLOOD		MAXIMUM EBB		
	TIME HOURS	VELOCITY DATA	TIME HOURS	VELOCITY DATA	
A	6:0	0.1	2.0	1.6	96.0
B	8:0	2.1	2.0	1.8	45.9
E	9:0	1.8	1.0	1.7	50.4
BM	9:0	2.0	1.0	1.6	50.6

SCH	BOTTOM				EBB PRE- DOMINANCE
	MAXIMUM FLOOD		MAXIMUM EBB		
	TIME HOURS	VELOCITY DATA	TIME HOURS	VELOCITY DATA	
A	5:0	0.1	1.0	1.2	94.7
B	6:0	0.3	2.0	0.7	69.5
E	8:0	0.9	0.	0.9	49.2
BM	6:0	0.5	2.0	1.0	64.1

Note: Time is expressed in hours after moon's transit of 74th meridian.  
 Velocities are expressed in feet per second prototype.

TABLE 26  
 CHARLESTON HARBOR MODEL  
 BUSHY PARK WATER SUPPLY TESTS  
 CURRENT VELOCITIES FOR PINOPOLIS WEEKLY RELEASE HYDROGRAPHS  
 SCHEDULES A, B, E, AND BM  
 COOPER RIVER MILE 38

TIME IN HOURS	SURFACE			
	SCH A	SCH B	SCH E	SCH B-MOD
0.	-3.9	-3.3	-3.2	-3.0
1.0	-4.6	-4.0	-3.7	-3.7
2.0	-3.9	-4.2	-4.4	-4.4
3.0	-3.9	-3.7	-3.0	-3.2
4.0	-2.6	-0.3	-0.6	-0.5
5.0	-1.3	2.6	1.3	3.2
6.0	-0.4	4.0	1.5	4.6
7.0	0.2	4.0	1.7	4.7
8.0	0.7	4.1	1.6	4.7
9.0	0.3	3.9	1.5	4.4
10.0	-0.3	2.5	0.3	2.6
11.0	-2.2	-0.6	-0.8	-1.2

TIME IN HOURS	BOTTOM			
	SCH A	SCH B	SCH E	SCH B-MOD
0.	-3.4	-3.3	-2.3	-3.2
1.0	-4.1	-3.9	-2.5	-4.0
2.0	-4.3	-4.3	-2.9	-4.4
3.0	-4.5	-3.5	-2.5	-3.8
4.0	-2.5	-0.7	-0.5	-0.7
5.0	-1.1	2.0	1.0	2.5
6.0	-0.4	2.5	2.3	3.4
7.0	0.2	2.9	2.4	3.3
8.0	0.4	2.5	2.6	3.4
9.0	0.3	2.3	2.3	3.2
10.0	-1.3	0.8	2.3	2.1
11.0	-2.3	-1.1	-1.0	-0.9

SCH	SURFACE				
	MAXIMUM FLOOD		MAXIMUM EBB		EBB PRE- DOMINANCE
	TIME HOURS	VELOCITY DATA	TIME HOURS	VELOCITY DATA	
A	8.0	0.7	1.0	4.6	95.3
B	8.0	4.1	2.0	4.2	44.4
E	7.0	1.7	2.0	4.4	68.2
BM	7.0	4.7	2.0	4.4	41.4

SCH	BOTTOM				
	MAXIMUM FLOOD		MAXIMUM EBB		EBB PRE- DOMINANCE
	TIME HOURS	VELOCITY DATA	TIME HOURS	VELOCITY DATA	
A	8.0	0.4	3.0	4.5	96.7
B	7.0	2.9	2.0	4.3	57.5
E	8.0	2.6	2.0	2.9	49.7
BM	6.0	3.4	2.0	4.4	49.9

Note: Time is expressed in hours after moon's transit of 74th meridian.  
 Velocities are expressed in feet per second prototype.

**TABLE 27.**  
**CHARLESTON HARBOR MODEL**  
**BUSHY PARK WATER SUPPLY TESTS**  
**CURRENT VELOCITIES FOR PINOPOLIS WEEKLY RELEASE HYDROGRAPHS**  
**SCHEDULES A, B, E, AND BM**  
**COOPER RIVER MILE 40**

TIME IN HOURS	SURFACE			
	SCH A	SCH B	SCH E	SCH B-MOD
0.	-0.7	-0.5	-1.4	-1.1
1.0	-1.5	-0.9	-1.6	-1.6
2.0	-2.2	-1.1	-2.2	-2.1
3.0	-2.5	-1.6	-2.4	-1.7
4.0	-2.3	-0.8	-1.5	-1.1
5.0	-1.2	0.1	-0.1	0.1
6.0	-0.8	0.9	0.7	1.2
7.0	-0.4	1.0	1.1	1.0
8.0	0.3	0.9	1.0	0.9
9.0	0.2	0.9	0.9	0.9
10.0	0.2	0.8	0.6	0.9
11.0	-0.5	0.2	0.1	0.1

TIME IN HOURS	BOTTOM			
	SCH A	SCH B	SCH E	SCH B-MOD
0.	-1.5	-1.2	-0.8	-0.9
1.0	-1.9	-1.4	-1.7	-1.6
2.0	-2.3	-1.6	-2.1	-0.9
3.0	-2.0	-1.2	-2.0	-0.9
4.0	-2.1	-0.9	-1.1	-0.5
5.0	-1.6	-0.3	0.1	0.1
6.0	-1.1	0.1	0.4	1.2
7.0	-0.7	0.7	0.6	1.4
8.0	0.2	1.2	0.8	1.3
9.0	0.2	0.9	0.3	1.2
10.0	0.2	0.7	0.1	1.0
11.0	-0.8	0.1	0.1	0.1

SCH	SURFACE				EBB PRE- DOMINANCE
	MAXIMUM FLOOD		MAXIMUM EBB		
	TIME HOURS	VELOCITY DATA	TIME HOURS	VELOCITY DATA	
A	8.0	0.3	3.0	2.5	95.6
B	7.0	1.0	3.0	1.6	50.9
E	7.0	1.1	3.0	2.4	67.5
BM	6.0	1.2	2.0	2.1	62.5

SCH	BOTTOM				EBB PRE- DOMINANCE
	MAXIMUM FLOOD		MAXIMUM EBB		
	TIME HOURS	VELOCITY DATA	TIME HOURS	VELOCITY DATA	
A	8.0	0.2	2.0	2.3	97.2
B	8.0	1.2	2.0	1.6	64.5
E	8.0	0.8	2.0	2.1	76.2
BM	7.0	1.4	1.0	1.6	43.4

Note: Time is expressed in hours after moon's transit of 74th meridian.  
 Velocities are expressed in feet per second prototype.

**TABLE 28**  
**CHARLESTON HARBOR MODEL**  
**BUSHY PARK WATER SUPPLY TESTS**  
**CURRENT VELOCITIES FOR PINOPOLIS WEEKLY RELEASE HYDROGRAPHS**  
**SCHEDULES A, B, E, AND BM**  
**COOPER RIVER MILE 42**

TIME IN HOURS	SURFACE			
	SCH A	SCH B	SCH E	SCH B-MOD
0.	-0.5	-1.3	-2.4	-2.3
1.0	-1.1	-1.3	-3.0	-3.5
2.0	-2.0	-1.4	-3.8	-4.2
3.0	-2.2	-1.3	-4.0	-4.0
4.0	-2.2	-0.9	-3.0	-2.6
5.0	-1.2	-0.4	-0.4	0.5
6.0	-0.3	0.5	1.0	1.2
7.0	0.2	0.9	1.5	1.3
8.0	0.2	0.9	1.5	1.3
9.0	0.2	0.9	1.4	1.3
10.0	0.2	0.8	1.1	1.0
11.0	-0.4	0.3	0.2	0.3

TIME IN HOURS	BOTTOM			
	SCH A	SCH B	SCH E	SCH B-MOD
0.	-1.7	-1.2	-2.5	-2.6
1.0	-2.3	-1.7	-3.2	-3.4
2.0	-2.9	-1.7	-3.7	-3.9
3.0	-3.1	-1.6	-3.7	-4.0
4.0	-3.0	-1.4	-2.9	-2.6
5.0	-2.5	-0.3	-0.7	-0.3
6.0	-1.6	0.1	1.2	1.2
7.0	-1.0	0.7	1.7	1.7
8.0	-0.4	1.2	1.7	1.0
9.0	0.2	1.3	1.5	1.9
10.0	0.2	1.1	1.5	1.5
11.0	-0.6	0.8	0.5	0.3

SCH	SURFACE					
	MAXIMUM FLOOD			MAXIMUM EBB		EBB PRE- DOMINANCE
	TIME HOURS	VELOCITY DATA	TIME HOURS	VELOCITY DATA		
A	7.0	0.2	3.0	-2.2	94.8	
B	7.0	0.9	2.0	-1.4	64.7	
E	7.0	1.5	3.0	-4.0	71.3	
BM	7.0	1.3	2.0	-4.2	70.6	

SCH	BOTTOM					
	MAXIMUM FLOOD			MAXIMUM EBB		EBB PRE- DOMINANCE
	TIME HOURS	VELOCITY DATA	TIME HOURS	VELOCITY DATA		
A	9.0	0.2	3.0	3.1	98.7	
B	9.0	1.3	2.0	1.7	60.4	
E	7.0	1.7	2.0	3.7	67.6	
BM	8.0	1.9	3.0	4.0	66.7	

Note: Time is expressed in hours after moon's transit of 74th meridian.  
 Velocities are expressed in feet per second prototype.

TABLE 29  
 CHARLESTON HARBOR MODEL  
 BUSHY PARK WATER SUPPLY TESTS  
 CURRENT VELOCITIES FOR PINOPOLIS WEEKLY RELEASE HYDROGRAPHS  
 SCHEDULES A, B, E, AND BM  
 COOPER RIVER MILE 44

TIME IN HOURS	SURFACE			
	SCH A	SCH B	SCH E	SCH B-MOD
0.	-1.6	-1.3	-0.3	-0.7
1.0	-1.7	-1.3	-0.3	-0.8
2.0	-1.8	-1.2	-0.4	-0.8
3.0	-1.9	-1.0	-0.6	-0.6
4.0	-1.9	-0.9	-0.3	-0.1
5.0	-1.7	0.1	0.2	0.2
6.0	-1.6	1.0	0.3	0.1
7.0	-1.4	0.7	0.6	0.2
8.0	-1.1	0.6	0.5	0.1
9.0	-0.5	0.5	0.3	0.1
10.0	-0.8	0.2	0.2	0.1
11.0	-1.1	0.1	-0.5	0.1

TIME IN HOURS	BOTTOM			
	SCH A	SCH B	SCH E	SCH B-MOD
0.	-1.1	-1.8	-0.4	-1.2
1.0	-1.1	-1.6	-0.5	-1.2
2.0	-1.3	-1.6	-0.1	-1.1
3.0	-1.1	-1.6	0.1	-1.1
4.0	-1.3	-1.1	-0.3	-0.7
5.0	-1.1	0.1	0.4	0.3
6.0	-1.0	1.2	0.5	0.6
7.0	-0.6	0.9	0.6	0.6
8.0	-0.4	0.5	0.8	0.4
9.0	-0.3	0.4	0.6	0.5
10.0	-0.1	0.2	0.3	0.2
11.0	-0.5	0.1	-0.5	-0.3

SCH	SURFACE					
	MAXIMUM FLOOD			MAXIMUM FBB		EBB PRE- DOMINANCE
	TIME HOURS	VELOCITY DATA	TIME HOURS	VELOCITY DATA		
A	9.0	-0.5	3.0	-1.9	100.8	
B	6.0	1.0	0.	-1.3	62.9	
E	7.0	0.6	3.0	0.6	56.2	
BM	5.0	0.2	1.0	-0.8	72.3	

SCH	BOTTOM					
	MAXIMUM FLOOD			MAXIMUM FBB		EBB PRE- DOMINANCE
	TIME HOURS	VELOCITY DATA	TIME HOURS	VELOCITY DATA		
A	10.0	-0.1	2.0	-1.3	100.8	
B	6.0	1.2	0.	1.8	69.2	
E	8.0	0.8	1.0	0.5	37.6	
BM	6.0	0.6	0.	1.2	69.3	

Note: Time is expressed in hours after moon's transit of 74th meridian.  
 Velocities are expressed in feet per second prototype.

TABLE 30  
 CHARLESTON HARBOR MODEL  
 BUSHY PARK WATER SUPPLY TESTS  
 CURRENT VELOCITIES FOR PINOPOLIS WEEKLY RELEASE HYDROGRAPHS  
 SCHEDULES A, B, E, AND BM  
 WANDO RIVER MILE 01

TIME IN HOURS	SURFACE			
	SCH A	SCH B	SCH E	SCH B-MOD
0.	-2.0	-1.6	-1.4	-1.4
1.0	-1.2	-0.6	-0.5	-0.6
2.0	0.1	0.1	0.2	0.3
3.0	1.7	1.6	1.3	1.4
4.0	1.9	1.6	1.4	1.6
5.0	1.9	1.6	1.1	1.2
6.0	1.6	1.4	1.1	1.1
7.0	1.0	0.9	0.6	0.8
8.0	-0.4	0.1	-0.5	0.1
9.0	-1.7	-1.6	-1.5	-1.4
10.0	-2.8	-2.3	-2.5	-2.9
11.0	-2.9	-2.2	-2.4	-2.1

TIME IN HOURS	BOTTOM			
	SCH A	SCH B	SCH E	SCH B-MOD
0.	-0.5	-1.6	-1.4	-1.0
1.0	0.1	-0.7	-0.6	-0.3
2.0	0.9	0.1	0.5	0.8
3.0	1.4	1.2	1.3	1.5
4.0	1.2	1.7	1.5	1.6
5.0	1.3	1.6	1.2	1.6
6.0	1.3	1.2	1.1	1.1
7.0	1.0	0.7	1.0	0.8
8.0	0.5	0.1	-0.3	0.1
9.0	-0.5	-1.4	-1.3	-0.8
10.0	-1.0	-2.3	-2.2	-2.0
11.0	-1.1	-2.3	-2.3	-2.3

SCH	SURFACE				
	MAXIMUM FLOOD		MAXIMUM EBB		EBB PRE- DOMINANCE
	TIME HOURS	VELOCITY DATA	TIME HOURS	VELOCITY DATA	
A	4.0	1.9	11.0	2.9	59.6
B	3.0	1.6	10.0	2.3	55.4
E	4.0	1.4	10.0	2.5	63.3
BM	4.0	1.6	10.0	-2.5	58.3

SCH	BOTTOM				
	MAXIMUM FLOOD		MAXIMUM EBB		EBB PRE- DOMINANCE
	TIME HOURS	VELOCITY DATA	TIME HOURS	VELOCITY DATA	
A	3.0	1.4	11.0	1.1	31.5
B	4.0	1.7	10.0	2.3	57.8
E	4.0	1.5	11.0	2.3	57.9
BM	4.0	1.6	11.0	-2.3	40.6

Note: Time is expressed in hours after moon's transit of 74th meridian.  
 Velocities are expressed in feet per second prototype.

**TABLE 31**  
**CHARLESTON HARBOR MODEL**  
**BUSHY PARK WATER SUPPLY TESTS**  
**CURRENT VELOCITIES FOR PINOPOLIS WEEKLY RELEASE HYDROGRAPHS**  
**SCHEDULES A, B, E, AND BM**  
**WANDO RIVER MILE 03**

TIME IN HOURS	SURFACE			
	SCH A	SCH B	SCH E	SCH B-MOD
0.	-2.0	-1.9	-1.4	-2.1
1.0	-0.8	-0.9	-0.5	-0.8
2.0	0.9	0.1	0.6	0.6
3.0	2.7	2.3	2.2	1.7
4.0	2.7	2.3	1.5	1.6
5.0	2.3	1.9	1.5	1.5
6.0	1.8	1.6	1.1	1.2
7.0	1.2	1.0	1.1	0.8
8.0	0.1	0.1	-0.1	0.3
9.0	-2.0	-1.9	-1.9	-2.2
10.0	-3.4	-3.2	-3.2	-3.9
11.0	-2.5	-3.1	-2.7	-3.1

TIME IN HOURS	BOTTOM			
	SCH A	SCH B	SCH E	SCH B-MOD
0.	-2.1	-2.3	-2.0	-1.9
1.0	-1.1	-1.2	-1.1	-0.8
2.0	1.0	0.1	0.5	0.6
3.0	2.6	2.4	2.0	1.7
4.0	2.6	2.3	1.9	1.6
5.0	2.5	2.1	1.8	1.6
6.0	2.0	2.0	1.7	1.4
7.0	1.5	1.6	1.4	0.8
8.0	0.8	0.1	-0.1	0.3
9.0	-1.3	-1.4	-1.2	-1.4
10.0	-3.2	-3.1	-3.4	-3.1
11.0	-3.2	-3.1	-3.2	-3.0

SCH	SURFACE					
	MAXIMUM FLOOD			MAXIMUM EBB		
	TIME HOURS	VELOCITY DATA	TIME HOURS	VELOCITY DATA	EBB PRE- DOMINANCE	
A	3.0	2.7	10.0	3.4	49.5	
B	3.0	2.3	10.0	3.2	56.0	
E	3.0	2.2	10.0	3.2	56.9	
BM	3.0	1.7	10.0	3.9	63.4	

SCH	BOTTOM					
	MAXIMUM FLOOD			MAXIMUM EBB		
	TIME HOURS	VELOCITY DATA	TIME HOURS	VELOCITY DATA	EBB PRE- DOMINANCE	
A	3.0	2.6	10.0	3.2	48.7	
B	3.0	2.4	10.0	3.1	53.6	
E	3.0	2.0	10.0	3.4	56.3	
BM	3.0	1.7	10.0	3.1	58.2	

Note: Time is expressed in hours after moon's transit of 74th meridian.  
 Velocities are expressed in feet per second prototype.

TABLE 32  
 CHARLESTON HARBOR MODEL  
 BUSHY PARK WATER SUPPLY TESTS  
 CURRENT VELOCITIES FOR PINOPOLIS WEEKLY RELEASE HYDROGRAPHS  
 SCHEDULES A, B, E, AND BM  
 WANDO RIVER MILE 05

TIME IN HOURS	SURFACE			
	SCH A	SCH B	SCH E	SCH B-MOD
0.	-3.7	-3.0	-2.2	-1.6
1.0	-2.2	-1.2	-1.4	-1.0
2.0	0.7	0.1	0.3	0.4
3.0	3.1	2.3	1.4	2.1
4.0	3.1	2.3	1.7	2.3
5.0	2.3	2.1	1.6	1.9
6.0	2.1	1.6	1.5	1.6
7.0	1.8	1.3	1.1	1.4
8.0	0.7	0.1	0.3	0.4
9.0	-1.3	-1.7	-2.0	-1.7
10.0	-3.7	-4.0	-4.1	-3.9
11.0	-4.3	-4.0	-3.5	-3.3

TIME IN HOURS	BOTTOM			
	SCH A	SCH B	SCH E	SCH B-MOD
0.	-3.0	-2.3	-2.2	-2.3
1.0	-1.6	-1.3	-1.1	-1.0
2.0	0.9	0.1	0.5	0.4
3.0	3.0	2.0	2.0	2.1
4.0	2.8	2.1	2.0	2.3
5.0	2.3	1.9	1.7	1.9
6.0	2.1	1.4	1.3	1.5
7.0	2.0	0.9	1.1	1.5
8.0	0.9	0.1	0.3	0.4
9.0	-1.2	-1.4	-1.7	-1.4
10.0	-3.2	-3.0	-2.3	-4.0
11.0	-3.3	-3.4	-2.3	-3.4

SCH	SURFACE				
	MAXIMUM FLOOD		MAXIMUM EBB		EBB PRE- DOMINANCE
	TIME HOURS	VELOCITY DATA	TIME HOURS	VELOCITY DATA	
A	3.0	3.1	11.0	4.3	55.0
B	3.0	2.3	10.0	4.0	60.7
E	4.0	1.7	10.0	4.1	64.9
BM	4.0	2.3	10.0	3.9	55.8

SCH	BOTTOM				
	MAXIMUM FLOOD		MAXIMUM EBB		EBB PRE- DOMINANCE
	TIME HOURS	VELOCITY DATA	TIME HOURS	VELOCITY DATA	
A	3.0	3.0	11.0	3.3	49.4
B	4.0	2.1	11.0	3.4	60.4
E	3.0	2.0	10.0	2.3	54.2
BM	4.0	2.3	10.0	4.0	56.9

Note: Time is expressed in hours after moon's transit of 74th meridian.  
 Velocities are expressed in feet per second prototype.

**TABLE 33-**  
**CHARLESTON HARBOR MODEL**  
**BUSHY PARK WATER SUPPLY TESTS**  
**CURRENT VELOCITIES FOR PINOPOLIS WEEKLY RELEASE HYDROGRAPHS**  
**SCHEDULES A, B, E, AND BM**  
**WANDO RIVER MILE 07**

TIME IN HOURS	SURFACE			
	SCH A	SCH B	SCH E	SCH B-MOD
0.	-1.9	-0.9	-1.4	-0.9
1.0	-1.4	-0.9	0.1	-1.0
2.0	-0.1	0.1	0.1	0.1
3.0	1.4	1.2	1.2	1.3
4.0	1.4	1.3	1.2	1.8
5.0	1.1	1.2	1.2	1.7
6.0	1.0	1.0	1.0	1.5
7.0	1.0	1.0	0.7	1.4
8.0	0.7	0.5	0.4	0.7
9.0	-0.5	0.1	-0.1	-0.1
10.0	-1.8	-1.2	-1.1	-1.6
11.0	-2.0	-1.7	-1.8	-1.8

TIME IN HOURS	BOTTOM			
	SCH A	SCH B	SCH E	SCH B-MOD
0.	-1.9	-1.4	-1.2	-1.5
1.0	-1.4	-0.9	-0.6	-1.0
2.0	-0.5	0.1	0.3	0.1
3.0	1.2	0.9	0.7	1.1
4.0	1.3	1.0	0.9	1.6
5.0	1.0	1.0	0.9	1.5
6.0	1.0	1.0	0.8	1.4
7.0	1.0	0.7	0.6	1.1
8.0	0.5	0.3	0.5	0.3
9.0	-0.5	0.1	-0.3	-1.5
10.0	-1.8	-0.9	-0.9	-2.2
11.0	-2.1	-1.2	-0.9	-2.1

SCH	SURFACE					
	MAXIMUM FLOOD		MAXIMUM EBB		EBB PRE- DOMINANCE	
	TIME HOURS	VELOCITY DATA	TIME HOURS	VELOCITY DATA		
A	3.0	1.4	11.0	-2.0	56.2	
B	4.0	1.3	11.0	-1.7	44.2	
E	3.0	1.2	11.0	1.8	45.5	
BM	4.0	1.8	11.0	1.8	42.1	

SCH	BOTTOM					
	MAXIMUM FLOOD		MAXIMUM EBB		EBB PRE- DOMINANCE	
	TIME HOURS	VELOCITY DATA	TIME HOURS	VELOCITY DATA		
A	4.0	1.3	11.0	-2.1	59.9	
B	4.0	1.0	0.	1.4	48.5	
E	4.0	0.9	0.	1.2	47.2	
BM	4.0	1.6	10.0	-2.2	57.6	

Note: Time is expressed in hours after moon's transit of 74th meridian.  
 Velocities are expressed in feet per second prototype.

TABLE 34  
 CHARLESTON HARBOR MODEL  
 BUSHY PARK WATER SUPPLY TESTS  
 CURRENT VELOCITIES FOR PINOPOLIS WEEKLY RELEASE HYDROGRAPHS  
 SCHEDULES A, B, E, AND BM  
 WANDO RIVER MILE 09

TIME IN HOURS	SURFACE			
	SCH A	SCH B	SCH E	SCH B-MOD
0.	-1.2	-2.3	-2.6	-3.3
1.0	-1.0	-1.7	-1.8	-2.6
2.0	-0.5	0.1	0.3	-1.0
3.0	1.8	3.8	1.1	2.4
4.0	1.7	2.8	3.1	2.4
5.0	-2.1	1.7	2.1	1.7
6.0	1.4	1.7	1.4	1.4
7.0	1.2	1.3	1.0	1.2
8.0	0.8	0.9	-0.6	0.4
9.0	-0.5	0.1	-1.0	-1.6
10.0	-1.4	-1.6	-2.7	-3.2
11.0	-1.4	-2.3	-3.0	-3.5

TIME IN HOURS	BOTTOM			
	SCH A	SCH B	SCH E	SCH B-MOD
0.	-1.3	-1.6	-2.9	-3.2
1.0	-1.0	-1.0	-1.9	-1.7
2.0	-0.5	0.1	0.5	-0.5
3.0	1.4	3.9	2.9	2.1
4.0	1.8	3.0	2.1	1.7
5.0	2.4	2.0	1.4	1.0
6.0	1.9	1.6	1.1	0.9
7.0	1.4	1.6	0.8	0.8
8.0	0.7	0.8	0.3	0.4
9.0	-0.4	0.1	-1.0	-1.0
10.0	-1.2	-1.5	-2.4	-2.8
11.0	-1.4	-1.6	-2.9	-3.6

SCH	SURFACE					
	TIME HOURS	MAXIMUM FLOOD		MAXIMUM EBB		EBB PRE- DOMINANCE
		VELOCITY DATA	TIME HOURS	VELOCITY DATA	TIME HOURS	
A	5.0	2.1	10.0	-1.4	42.3	
B	3.0	3.8	0.	-2.3	42.0	
E	4.0	3.1	11.0	-3.0	59.1	
BM	3.0	2.6	11.0	-3.5	63.2	

SCH	BOTTOM					
	TIME HOURS	MAXIMUM FLOOD		MAXIMUM EBB		EBB PRE- DOMINANCE
		VELOCITY DATA	TIME HOURS	VELOCITY DATA	TIME HOURS	
A	5.0	2.4	11.0	-1.4	40.3	
B	3.0	3.9	0.	-1.6	33.8	
E	3.0	2.9	11.0	-2.9	57.5	
BM	3.0	2.1	11.0	-3.6	67.3	

Note: Time is expressed in hours after moon's transit of 74th meridian.  
 Velocities are expressed in feet per second prototype.

**TABLE 35**  
**CHARLESTON HARBOR MODEL**  
**BUSHY PARK WATER SUPPLY TESTS**  
**CURRENT VELOCITIES FOR PINOPOLIS WEEKLY RELEASE HYDROGRAPHS**  
**SCHEDULES A, B, E, AND BM**  
**WANDO RIVER MILE 13**

TIME IN HOURS	MIDDEPTH			
	SCH A	SCH B	SCH E	SCH B-MOD
0.	-2.2	-2.3	-1.8	-1.6
1.0	-2.1	-2.5	-1.5	-1.1
2.0	-1.3	-0.4	-0.3	0.1
3.0	0.5	1.6	0.1	1.6
4.0	1.5	1.6	1.4	1.6
5.0	1.3	1.0	1.1	1.4
6.0	1.0	0.9	0.9	1.0
7.0	0.9	0.9	0.7	0.9
8.0	0.7	0.7	0.7	0.6
9.0	-0.4	0.1	0.1	0.1
10.0	-2.0	-2.0	-0.9	-1.6
11.0	-2.0	-2.3	-1.6	-1.6

SCH	MAXIMUM FLOOD		MAXIMUM EBB		EBB PRE- DOMINANCE
	TIME HOURS	VELOCITY DATA	TIME HOURS	VELOCITY DATA	
A	4.0	1.5	0.	-2.2	65.0
B	3.0	1.6	1.0	-2.5	60.6
E	4.0	1.4	0.	-1.8	58.3
BM	3.0	1.6	0.	-1.6	46.9

Note: Time is expressed in hours after moon's transit of 74th meridian.  
 Velocities are expressed in feet per second positive.

**TABLE 36**  
**CHARLESTON HARBOR MODEL**  
**BUSHY PARK WATER SUPPLY TESTS**  
**CURRENT VELOCITIES FOR PINOPOLIS WEEKLY RELEASE HYDROGRAPHS**  
**SCHEDULES A, B, E, AND BM**  
**ASHLEY RIVER MILE 01**

TIME IN HOURS	SURFACE			
	SCH A	SCH B	SCH E	SCH B-MOD
0.	-1.5	-2.0	-1.8	-1.7
1.0	-0.9	-0.6	-0.9	-0.7
2.0	-0.8	0.5	0.1	0.3
3.0	0.6	1.9	1.7	1.9
4.0	0.9	1.9	1.4	2.1
5.0	0.8	2.0	1.2	2.0
6.0	1.5	1.5	1.0	1.3
7.0	0.1	0.6	0.3	0.7
8.0	0.1	-0.8	0.1	-0.6
9.0	-1.4	-1.5	-2.0	-1.6
10.0	-1.4	-2.0	-2.1	-1.9
11.0	-1.6	-2.3	-2.2	-2.0

TIME IN HOURS	BOTTOM			
	SCH A	SCH B	SCH E	SCH B-MOD
0.	-0.9	-1.4	-1.1	-0.9
1.0	-0.3	-0.3	-0.4	-0.1
2.0	0.8	0.9	0.1	1.0
3.0	0.8	1.5	1.7	2.0
4.0	1.3	1.6	1.5	2.1
5.0	1.2	1.5	1.5	1.6
6.0	1.3	1.6	1.2	1.4
7.0	0.8	0.7	0.8	0.9
8.0	-0.3	-0.1	0.1	0.1
9.0	-0.9	-1.4	-1.4	-1.0
10.0	-1.4	-1.8	-1.6	-1.3
11.0	-1.5	-2.1	-1.6	-1.9

SCH	SURFACE				EBB PRE- DOMINANCE
	MAXIMUM FLOOD		MAXIMUM EBB		
	TIME HOURS	VELOCITY DATA	TIME HOURS	VELOCITY DATA	
A	6.0	1.5	11.0	-1.6	67.2
B	5.0	2.0	11.0	-2.3	55.0
E	3.0	1.7	11.0	-2.2	62.3
BM	4.0	2.1	11.0	-2.0	52.7

SCH	BOTTOM				EBB PRE- DOMINANCE
	MAXIMUM FLOOD		MAXIMUM EBB		
	TIME HOURS	VELOCITY DATA	TIME HOURS	VELOCITY DATA	
A	4.0	1.3	11.0	-1.5	48.8
B	4.0	1.6	11.0	-2.1	50.3
E	3.0	1.7	10.0	-1.6	49.8
BM	4.0	2.1	11.0	-1.9	39.3

Note: Time is expressed in hours after moon's transit of 74th meridian.  
 Velocities are expressed in feet per second prototype.

TABLE 37  
 CHARLESTON HARBOR MODEL  
 BUSHY PARK WATER SUPPLY TESTS  
 CURRENT VELOCITIES FOR PINOPOLIS WEEKLY RELEASE HYDROGRAPHS  
 SCHEDULES A, B, E, AND BM  
 ASHLEY RIVER MILE 03

TIME IN HOURS	SURFACE			
	SCH A	SCH B	SCH E	SCH B-MOD
0.	-1.7	-1.9	-1.4	-1.6
1.0	-1.0	-1.0	-0.7	-0.9
2.0	0.1	0.1	0.1	0.2
3.0	0.7	0.8	0.9	0.9
4.0	1.0	0.8	0.6	0.9
5.0	0.7	0.6	0.7	0.7
6.0	0.1	0.4	0.4	0.3
7.0	0.1	0.3	0.3	0.3
8.0	0.1	0.1	0.1	-0.1
9.0	-1.2	-0.9	-0.8	-1.1
10.0	-2.2	-2.2	-1.3	-2.0
11.0	-2.2	-2.3	-1.5	-2.0

TIME IN HOURS	BOTTOM			
	SCH A	SCH B	SCH E	SCH B-MOD
0.	0.1	-0.7	-0.8	-0.5
1.0	0.1	-0.5	-0.5	-0.5
2.0	0.1	0.3	0.1	0.5
3.0	1.2	1.3	1.2	1.3
4.0	0.8	1.0	1.2	1.3
5.0	0.9	1.1	1.1	1.3
6.0	0.9	0.7	0.8	0.7
7.0	0.8	0.5	0.6	0.5
8.0	0.1	0.1	0.1	0.1
9.0	0.1	-0.4	-0.4	-0.5
10.0	-1.0	-1.3	-1.3	-1.2
11.0	-0.6	-1.0	-1.1	-0.8

SCH	SURFACE					
	MAXIMUM FLOOD		MAXIMUM EBB		EBB PRE- DOMINANCE	
	TIME HOURS	VELOCITY DATA	TIME HOURS	VELOCITY DATA		
A	4.0	1.0	10.0	2.2	75.9	
B	3.0	0.8	11.0	2.3	74.3	
E	3.0	0.9	11.0	1.5	67.8	
BM	3.0	0.9	10.0	2.0	70.4	

SCH	BOTTOM					
	MAXIMUM FLOOD		MAXIMUM EBB		EBB PRE- DOMINANCE	
	TIME HOURS	VELOCITY DATA	TIME HOURS	VELOCITY DATA		
A	3.0	1.2	10.0	1.0	25.3	
B	3.0	1.3	10.0	1.3	45.2	
E	3.0	1.2	10.0	1.3	46.6	
BM	3.0	1.3	10.0	1.2	39.8	

Note: Time is expressed in hours after moon's transit of 74th meridian.  
 Velocities are expressed in feet per second prototype.

**TABLE 38**  
**CHARLESTON HARBOR MODEL**  
**BUSHY PARK WATER SUPPLY TESTS**  
**CURRENT VELOCITIES FOR PINOPOLIS WEEKLY RELEASE HYDROGRAPHS**  
**SCHEDULES A, B, E, AND BM**  
**ASHLEY RIVER MILE 05**

TIME IN HOURS	SURFACE			
	SCH A	SCH B	SCH E	SCH B-MOD
0.	-2.5	-2.3	-2.4	-2.1
1.0	-1.5	-1.0	-1.2	-1.3
2.0	-0.1	0.1	0.1	0.6
3.0	2.1	2.0	1.6	2.2
4.0	2.0	1.7	1.6	2.1
5.0	1.8	1.8	1.7	1.8
6.0	1.1	1.6	1.6	1.7
7.0	0.9	1.0	1.1	0.9
8.0	0.1	0.1	0.1	-0.3
9.0	-2.2	-2.3	-1.8	-2.1
10.0	-3.3	-3.0	-3.0	-3.1
11.0	-3.0	-3.0	-2.8	-2.9

TIME IN HOURS	BOTTOM			
	SCH A	SCH B	SCH E	SCH B-MOD
0.	-1.9	-1.8	-1.7	-1.6
1.0	-1.0	-0.9	-0.9	-0.7
2.0	0.1	0.1	0.1	1.1
3.0	2.3	2.3	2.3	2.4
4.0	2.1	2.1	2.2	2.1
5.0	2.2	1.6	2.0	1.7
6.0	1.6	1.6	1.4	1.5
7.0	1.0	1.0	1.0	0.9
8.0	0.1	0.1	0.1	0.2
9.0	-1.4	-1.5	-1.6	-1.6
10.0	-2.5	-2.6	-3.0	-2.6
11.0	-2.4	-2.7	-2.4	-2.1

SCH	SURFACE				EBB PRE- DOMINANCE
	MAXIMUM FLOOD		MAXIMUM EBB		
	TIME HOURS	VELOCITY DATA	TIME HOURS	VELOCITY DATA	
A	3.0	2.1	10.0	3.3	62.7
B	3.0	2.0	10.0	3.0	60.1
E	5.0	1.7	10.0	3.0	60.9
BM	3.0	2.2	10.0	3.1	58.5

SCH	BOTTOM				EBB PRE- DOMINANCE
	MAXIMUM FLOOD		MAXIMUM EBB		
	TIME HOURS	VELOCITY DATA	TIME HOURS	VELOCITY DATA	
A	3.0	2.3	10.0	2.5	51.6
B	3.0	2.3	11.0	2.7	53.7
E	3.0	2.3	10.0	3.0	53.1
BM	3.0	2.4	10.0	2.6	48.8

Note: Time is expressed in hours after moon's transit of 74th meridian.  
 Velocities are expressed in feet per second prototype.

TABLE 39  
 CHARLESTON HARBOR MODEL  
 BUSHY PARK WATER SUPPLY TESTS  
 CURRENT VELOCITIES FOR PINOPOLIS WEEKLY RELEASE HYDROGRAPHS  
 SCHEDULES A, B, E, AND BM  
 ASHLEY RIVER MILE 07

TIME IN HOURS	SURFACE			
	SCH A	SCH B	SCH E	SCH B-MOD
0.	-2.2	-1.6	-0.9	-2.0
1.0	-1.5	-0.9	-0.9	-1.6
2.0	0.1	0.1	0.1	-0.3
3.0	1.7	1.0	1.2	1.2
4.0	1.6	0.9	1.6	1.6
5.0	1.5	1.0	1.3	1.3
6.0	1.3	0.9	1.2	1.2
7.0	0.7	0.6	0.9	0.9
8.0	0.1	0.1	0.1	0.1
9.0	-1.9	-1.6	-1.1	-1.3
10.0	-2.9	-1.9	-2.2	-2.7
11.0	-2.4	-1.7	-1.9	-2.5

TIME IN HOURS	BOTTOM			
	SCH A	SCH B	SCH E	SCH B-MOD
0.	-2.4	-1.6	-1.6	-2.1
1.0	-1.7	-0.8	-0.9	-1.2
2.0	0.1	0.1	0.1	-0.3
3.0	2.0	1.0	2.2	2.5
4.0	1.7	0.9	2.0	2.4
5.0	1.9	0.9	1.8	1.9
6.0	1.7	0.8	1.6	1.5
7.0	1.0	0.5	1.2	1.3
8.0	-0.3	0.1	0.1	0.3
9.0	-1.6	-1.0	-0.9	-1.0
10.0	-2.9	-2.3	-2.1	-2.1
11.0	-2.7	-2.1	-1.9	-2.3

SCH	SURFACE				
	MAXIMUM FLOOD		MAXIMUM EBB		EBB PRE- DOMINANCE
	TIME HOURS	VELOCITY DATA	TIME HOURS	VELOCITY DATA	
A	3.0	1.7	10.0	-2.9	62.5
B	3.0	1.0	10.0	-1.9	64.5
E	4.0	1.6	10.0	-2.2	54.8
BM	4.0	1.6	10.0	-2.7	64.1

SCH	BOTTOM				
	MAXIMUM FLOOD		MAXIMUM EBB		EBB PRE- DOMINANCE
	TIME HOURS	VELOCITY DATA	TIME HOURS	VELOCITY DATA	
A	3.0	2.0	10.0	-2.9	60.8
B	3.0	1.0	10.0	-2.3	66.6
E	3.0	2.2	10.0	-2.1	46.9
BM	3.0	2.5	11.0	-2.3	50.8

Note: Time is expressed in hours after moon's transit of 74th meridian.  
 Velocities are expressed in feet per second prototype.

TABLE 40  
 CHARLESTON HARBOR MODEL  
 BUSHY PARK WATER SUPPLY TESTS  
 CURRENT VELOCITIES FOR PINOPOLIS WEEKLY RELEASE HYDROGRAPHS  
 SCHEDULES A, B, E, AND BM  
 CLOUTER CREEK MILE 01

TIME IN HOURS	SURFACE			
	SCH A	SCH B	SCH E	SCH B-MOD
0.	-0.9	-1.1	-0.5	-1.0
1.0	-0.7	-0.7	-0.5	-0.8
2.0	-0.3	0.2	0.1	-0.5
3.0	0.5	0.5	0.5	0.1
4.0	0.8	0.7	0.5	0.8
5.0	0.8	0.6	0.7	0.2
6.0	1.1	0.9	0.8	0.2
7.0	0.9	0.9	0.9	0.3
8.0	0.2	0.3	0.2	0.7
9.0	-1.6	-1.2	-1.0	0.1
10.0	-1.7	-1.6	-1.1	-1.3
11.0	-1.3	-1.3	-0.8	-0.8

TIME IN HOURS	BOTTOM			
	SCH A	SCH B	SCH E	SCH B-MOD
0.	-0.8	-0.3	0.1	-0.3
1.0	-0.1	-0.3	0.1	0.1
2.0	0.5	-0.1	0.1	0.5
3.0	0.7	0.5	0.1	0.3
4.0	0.8	0.5	0.7	0.2
5.0	0.6	0.6	0.7	0.7
6.0	1.0	1.0	1.1	0.8
7.0	0.8	1.2	1.1	0.8
8.0	0.3	0.9	0.4	-0.5
9.0	-1.0	-1.1	-0.5	-0.3
10.0	-1.3	-1.1	-0.6	-0.9
11.0	-0.7	-0.6	-0.3	-0.5

SCH	SURFACE				EBB PRE- DOMINANCE
	MAXIMUM FLOOD		MAXIMUM EBB		
	TIME HOURS	VELOCITY DATA	TIME HOURS	VELOCITY DATA	
A	6:0	1.1	10.0	-1.7	61.5
B	6:0	0.9	10.0	-1.6	60.2
E	7:0	0.9	10.0	-1.1	52.7
BM	4:0	0.8	10.0	-1.3	65.1

SCH	BOTTOM				EBB PRE- DOMINANCE
	MAXIMUM FLOOD		MAXIMUM EBB		
	TIME HOURS	VELOCITY DATA	TIME HOURS	VELOCITY DATA	
A	6:0	1.0	10.0	-1.3	45.8
B	7:0	1.2	9.0	-1.1	44.1
E	6:0	1.1	10.0	-0.6	24.4
BM	6:0	0.8	10.0	-0.9	41.6

Note: Time is expressed in hours after moon's transit of 74th meridian.  
 Velocities are expressed in feet per second prototype.

TABLE 4.  
 CHARLESTON HARBOR MODEL  
 BUSHY PARK WATER SUPPLY TESTS  
 CURRENT VELOCITIES FOR PINOPOLIS WEEKLY RELEASE HYDROGRAPHS  
 SCHEDULES A, B, C, AND D  
 COOPER RIVER MILE 30

TIME IN HOURS	SURFACE			
	SCH A	SCH B	SCH C	SCH D
0.	-2.5	-1.7	-0.8	-1.6
1.0	-2.6	-2.0	-1.0	-1.3
2.0	-2.3	-1.9	-0.9	-1.4
3.0	-1.4	-0.6	-0.8	-0.7
4.0	-0.3	0.2	0.1	0.1
5.0	0.1	0.7	0.4	0.5
6.0	0.3	0.6	1.4	1.0
7.0	0.4	0.4	1.4	0.9
8.0	0.2	0.3	1.2	0.6
9.0	0.1	0.1	1.0	0.3
10.0	-0.3	-0.3	0.1	-0.3
11.0	-1.5	-1.0	-0.9	-0.9

TIME IN HOURS	BOTTOM			
	SCH A	SCH B	SCH C	SCH D
0.	-2.1	-2.3	-2.0	-1.7
1.0	-2.3	-2.3	-2.3	-2.3
2.0	-2.4	-2.3	-1.8	-2.1
3.0	-2.0	-1.5	-1.3	-1.0
4.0	-0.6	0.1	0.1	0.1
5.0	0.1	0.4	0.4	0.6
6.0	0.1	1.3	0.6	0.7
7.0	0.1	1.3	0.8	0.8
8.0	0.3	0.8	0.9	0.6
9.0	0.1	0.6	0.5	0.3
10.0	-0.7	0.3	0.1	0.1
11.0	-1.6	-0.5	-0.3	-0.8

SCH	SURFACE				EBR PRE- DOMINANCE
	MAXIMUM FLOOD		MAXIMUM EBB		
	TIME HOURS	VELOCITY DATA	TIME HOURS	VELOCITY DATA	
A	7.0	0.4	1.0	2.6	92.0
B	5.0	0.7	1.0	2.0	77.9
C	6.0	1.4	1.0	1.0	46.8
D	6.0	1.0	0.	1.6	66.8

SCH	BOTTOM				EBR PRE- DOMINANCE
	MAXIMUM FLOOD		MAXIMUM EBB		
	TIME HOURS	VELOCITY DATA	TIME HOURS	VELOCITY DATA	
A	8.0	0.3	2.0	2.4	94.9
B	6.0	1.3	1.0	2.3	64.2
C	8.0	0.9	1.0	2.3	76.8
D	7.0	0.8	1.0	2.3	72.8

Note: Time is expressed in hours after moon's transit of 74th meridian.  
 Velocities are expressed in feet per second prototype.

TABLE 42  
 CHARLESTON HARBOR MODEL  
 BUSHY PARK WATER SUPPLY TESTS  
 CURRENT VELOCITIES FOR PINOPOLIS WEEKLY RELEASE HYDROGRAPHS  
 SCHEDULES A, B, C, AND D  
 COOPER RIVER MILE 34

TIME IN HOURS	SURFACE			
	SCH A	SCH B	SCH C	SCH D
0.	-0.5	-1.3	-1.4	-1.3
1.0	-0.5	-1.3	-1.5	-1.8
2.0	-0.5	-1.5	-1.3	-1.5
3.0	-0.4	-0.9	-0.9	-1.0
4.0	0.1	0.1	-0.5	0.1
5.0	0.1	1.1	0.1	0.3
6.0	0.1	0.8	0.2	0.1
7.0	0.1	0.5	0.1	0.1
8.0	0.1	0.5	0.1	0.1
9.0	0.1	0.5	0.1	0.1
10.0	0.1	-0.1	0.1	0.1
11.0	-0.3	-0.8	0.1	-0.3

TIME IN HOURS	BOTTOM			
	SCH A	SCH B	SCH C	SCH D
0.	-0.8	-0.8	-0.9	-0.9
1.0	-1.0	-1.0	-1.1	-1.0
2.0	-0.8	-0.8	-1.0	-0.9
3.0	-0.3	-0.5	-0.6	-0.8
4.0	0.1	0.1	0.1	0.1
5.0	0.1	0.8	0.3	0.4
6.0	0.1	1.4	0.8	0.6
7.0	0.1	1.5	1.0	0.9
8.0	0.1	1.4	1.2	0.9
9.0	0.1	1.3	1.4	0.8
10.0	0.1	0.7	0.9	0.6
11.0	-0.8	-0.5	0.1	0.1

SCH	SURFACE				
	MAXIMUM FLOOD		MAXIMUM EBB		EBB PRE- DOMINANCE
	TIME HOURS	VELOCITY DATA	TIME HOURS	VELOCITY DATA	
A	4.0	0.1	0.	0.5	84.6
B	5.0	1.1	2.0	1.5	64.2
C	6.0	0.2	0.	1.6	87.3
D	5.0	0.3	1.0	1.8	87.8

SCH	BOTTOM				
	MAXIMUM FLOOD		MAXIMUM EBB		EBB PRE- DOMINANCE
	TIME HOURS	VELOCITY DATA	TIME HOURS	VELOCITY DATA	
A	4.0	0.1	1.0	1.0	90.3
B	7.0	1.5	1.0	1.0	39.2
C	9.0	1.4	1.0	1.1	39.6
D	7.0	0.9	1.0	1.0	46.2

Note: Time is expressed in hours after moon's transit of 74th meridian.  
 Velocities are expressed in feet per second prototype.

**TABLE 43**  
**CHARLESTON HARBOR MODEL**  
**BUSHY PARK WATER SUPPLY TESTS**  
**CURRENT VELOCITIES FOR PINOPOLIS WEEKLY RELEASE HYDROGRAPHS**  
**SCHEDULES A, B, C, AND D**  
**COOPER RIVER MILE 38**

TIME IN HOURS	SURFACE			
	SCH A	SCH B	SCH C	SCH D
0.	-3.9	-3.3	-2.8	-3.1
1.0	-4.6	-4.0	-3.7	-4.0
2.0	-3.9	-4.2	-3.6	-4.5
3.0	-3.9	-3.7	-3.6	-4.0
4.0	-2.6	-0.3	-0.6	-0.8
5.0	-1.3	2.6	0.7	0.5
6.0	-0.4	4.0	1.7	1.1
7.0	0.2	4.0	2.0	1.5
8.0	0.7	4.1	2.2	1.7
9.0	0.3	3.9	2.2	1.5
10.0	-0.3	2.5	1.4	0.5
11.0	-2.2	-0.6	-0.3	-0.4

TIME IN HOURS	BOTTOM			
	SCH A	SCH B	SCH C	SCH D
0.	-3.4	-3.3	-1.8	-2.9
1.0	-4.1	-3.9	-2.4	-3.5
2.0	-4.3	-4.3	-2.7	-3.6
3.0	-4.5	-3.5	-2.3	-3.3
4.0	-2.5	-0.7	0.4	-0.7
5.0	-1.1	2.0	1.3	0.5
6.0	-0.4	2.5	2.4	1.9
7.0	0.2	2.9	2.9	1.8
8.0	0.4	2.5	3.2	2.0
9.0	0.3	2.3	3.0	1.3
10.0	-1.3	0.8	1.9	1.2
11.0	-2.3	-1.1	-0.5	-0.5

SCH	SURFACE					
	MAXIMUM FLOOD			MAXIMUM EBB		EBB PRE- DOMINANCE
	TIME HOURS	VELOCITY DATA	TIME HOURS	VELOCITY DATA		
A	8.0	0.7	1.0	-4.6	95.3	
B	8.0	4.1	2.0	4.2	44.4	
C	8.0	2.2	2.0	3.8	60.1	
D	8.0	1.7	2.0	4.5	71.5	

SCH	BOTTOM					
	MAXIMUM FLOOD			MAXIMUM EBB		EBB PRE- DOMINANCE
	TIME HOURS	VELOCITY DATA	TIME HOURS	VELOCITY DATA		
A	8.0	0.4	3.0	-4.5	96.7	
B	7.0	2.9	2.0	4.3	57.5	
C	8.0	2.0	2.0	3.6	64.0	
D	8.0	3.2	2.0	2.7	40.6	

Note: Time is expressed in hours after moon's transit of 74th meridian.  
 Velocities are expressed in feet per second prototype.

TABLE 44  
 CHARLESTON HARBOR MODEL  
 BUSHY PARK WATER SUPPLY TESTS  
 CURRENT VELOCITIES FOR PINOPOLIS WEEKLY RELEASE HYDROGRAPHS  
 SCHEDULES A, B, C, AND D  
 COOPER RIVER MILE 42

TIME IN HOURS	SURFACE			
	SCH A	SCH B	SCH C	SCH D
0.	-0.5	-1.3	-1.3	-1.3
1.0	-1.1	-1.3	-2.1	-2.0
2.0	-2.0	-1.4	-2.6	-2.3
3.0	-2.2	-1.3	-2.7	-2.6
4.0	-2.2	-0.9	-2.2	-1.9
5.0	-1.2	-0.4	-1.0	-0.3
6.0	-0.3	0.5	0.9	0.7
7.0	0.2	0.9	1.1	1.3
8.0	0.2	0.9	1.2	0.9
9.0	0.2	0.9	1.3	1.1
10.0	0.2	0.8	0.7	0.8
11.0	-0.4	0.3	0.2	0.3

TIME IN HOURS	BOTTOM			
	SCH A	SCH B	SCH C	SCH D
0.	-1.7	-1.2	-1.4	-1.0
1.0	-2.3	-1.7	-2.1	-1.7
2.0	-2.9	-1.7	-2.2	-2.0
3.0	-3.1	-1.6	-2.2	-2.1
4.0	-3.0	-1.4	-1.9	-1.3
5.0	-2.5	-0.3	-0.6	0.1
6.0	-1.6	0.1	0.5	0.6
7.0	-1.0	0.7	1.0	1.2
8.0	-0.4	1.2	1.0	1.3
9.0	0.2	1.3	1.0	1.3
10.0	0.2	1.1	1.0	1.1
11.0	-0.6	0.8	1.0	0.6

SCH	SURFACE					
	MAXIMUM FLOOD			MAXIMUM EBB		EBB PRE- DOMINANCE
	TIME HOURS	VELOCITY DATA	TIME HOURS	VELOCITY DATA		
A	7.0	0.2	3.0	2.2	94.8	
B	7.0	0.9	2.0	-1.4	64.7	
C	9.0	1.3	3.0	-2.7	68.2	
D	7.0	1.3	3.0	-2.6	67.6	

SCH	BOTTOM					
	MAXIMUM FLOOD			MAXIMUM EBB		EBB PRE- DOMINANCE
	TIME HOURS	VELOCITY DATA	TIME HOURS	VELOCITY DATA		
A	9.0	0.2	3.0	3.1	98.2	
B	9.0	1.3	2.0	1.7	60.4	
C	7.0	1.0	2.0	2.2	65.6	
D	8.0	1.3	3.0	2.1	57.6	

Note: Time is expressed in hours after moon's transit of 74th meridian.  
 Velocities are expressed in feet per second prototype.

TABLE 45  
 CHARLESTON HARBOR MODEL  
 BUSHY PARK WATER SUPPLY TESTS  
 CURRENT VELOCITIES FOR PINOPOLIS WEEKLY RELEASE HYDROGRAPHS  
 SCHEDULES A, B, C, AND D  
 COOPER RIVER MILE 44

TIME IN HOURS	SURFACE			
	SCH A	SCH B	SCH C	SCH D
0.	-1.6	-1.3	-0.9	-1.3
1.0	-1.7	-1.3	-1.6	-1.6
2.0	-1.8	-1.2	-1.8	-1.6
3.0	-1.9	-1.0	-1.4	-1.4
4.0	-1.9	-0.9	-1.1	-1.1
5.0	-1.7	0.1	0.1	0.1
6.0	-1.6	1.0	1.1	0.7
7.0	-1.4	0.7	1.3	0.9
8.0	-1.1	0.6	1.1	0.6
9.0	-0.5	0.5	0.9	0.4
10.0	-0.8	0.2	0.9	0.3
11.0	-1.1	0.1	0.3	0.1

TIME IN HOURS	BOTTOM			
	SCH A	SCH B	SCH C	SCH D
0.	-1.1	-1.8	-1.6	-1.0
1.0	-1.1	-1.6	-2.0	-1.1
2.0	-1.3	-1.6	-1.8	-0.9
3.0	-1.1	-1.6	-1.9	-0.9
4.0	-1.3	-1.1	-1.6	-0.4
5.0	-1.1	0.1	0.1	0.1
6.0	-1.0	1.2	1.4	1.2
7.0	-0.6	0.9	1.3	1.2
8.0	-0.4	0.9	1.3	0.9
9.0	-0.3	0.4	1.0	0.6
10.0	-0.1	0.2	0.9	0.1
11.0	-0.5	0.1	0.1	-0.4

SCH	SURFACE				EBB PRE- DOMINANCE
	MAXIMUM FLOOD		MAXIMUM EBB		
	TIME HOURS	VELOCITY DATA	TIME HOURS	VELOCITY DATA	
A	9.0	-0.5	3.0	-1.9	100.8
B	6.0	1.0	0.	-1.3	62.9
C	7.0	1.3	2.0	-1.8	55.2
D	7.0	0.9	2.0	-1.6	68.2

SCH	BOTTOM				EBB PRE- DOMINANCE
	MAXIMUM FLOOD		MAXIMUM EBB		
	TIME HOURS	VELOCITY DATA	TIME HOURS	VELOCITY DATA	
A	10.0	-0.1	2.0	-1.3	100.8
B	6.0	1.2	0.	-1.8	69.2
C	6.0	1.4	1.0	-2.0	60.8
D	6.0	1.2	1.0	-1.1	53.9

Note: Time is expressed in hours after moon's transit of 74th meridian.  
 Velocities are expressed in feet per second prototype.



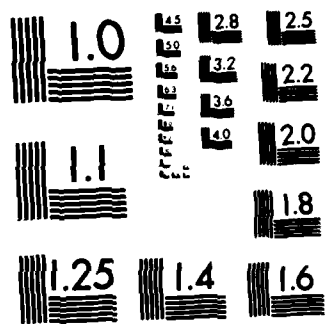

MICROCOPY RESOLUTION TEST CHART  
NATIONAL BUREAU OF STANDARDS-1963-A

TABLE 46  
 CHARLESTON HARBOR MODEL  
 BUSHY PARK WATER SUPPLY TESTS  
 CURRENT VELOCITIES FOR PINOPOLIS WEEKLY RELEASE HYDROGRAPHS  
 SCHEDULES A, B, C, AND D  
 WANDO RIVER MILE 3

TIME IN HOURS	SURFACE			
	SCH A	SCH B	SCH C	SCH D
0.	-2.0	-1.9	-1.6	-2.3
1.0	-0.8	-0.9	-0.7	-1.0
2.0	0.9	0.1	0.1	0.1
3.0	2.7	2.3	2.0	1.4
4.0	2.7	2.3	2.0	1.9
5.0	2.3	1.9	1.6	1.6
6.0	1.8	1.6	1.5	1.9
7.0	1.2	1.0	1.2	1.0
8.0	0.1	0.1	0.1	0.1
9.0	-2.0	-1.9	-2.0	-3.2
10.0	-3.4	-3.2	-3.1	-3.2
11.0	-2.5	-3.1	-2.4	-3.0

TIME IN HOURS	BOTTOM			
	SCH A	SCH B	SCH C	SCH D
0.	-2.1	-2.3	-1.8	-1.4
1.0	-1.1	-1.2	-1.1	-0.6
2.0	1.0	0.1	0.1	0.1
3.0	2.6	2.4	2.1	1.7
4.0	2.6	2.3	2.3	1.7
5.0	2.5	2.1	2.0	1.0
6.0	2.0	2.0	1.8	1.0
7.0	1.5	1.6	1.4	0.9
8.0	0.8	0.1	0.1	0.1
9.0	-1.3	-1.4	-1.4	-0.8
10.0	-3.2	-3.1	-3.1	-2.3
11.0	-3.2	-3.1	-2.4	-2.4

SCH	SURFACE				
	MAXIMUM FLOOD		MAXIMUM EBB		EBB PEE DOMINANCE
	TIME HOURS	VELOCITY DATA	TIME HOURS	VELOCITY DATA	
A	3.0	2.7	10.0	3.4	49.5
B	3.0	2.3	10.0	3.2	56.0
C	3.0	2.0	10.0	3.1	55.1
D	4.0	1.9	9.0	3.2	64.3

SCH	BOTTOM				
	MAXIMUM FLOOD		MAXIMUM EBB		EBB PEE DOMINANCE
	TIME HOURS	VELOCITY DATA	TIME HOURS	VELOCITY DATA	
A	3.0	2.6	10.0	3.2	48.2
B	3.0	2.4	10.0	3.1	53.6
C	4.0	2.3	10.0	3.1	51.4
D	3.0	1.7	11.0	2.4	56.4

Note: Time is expressed in hours after moon's transit of 74th meridian.  
 Velocities are expressed in feet per second prototype.









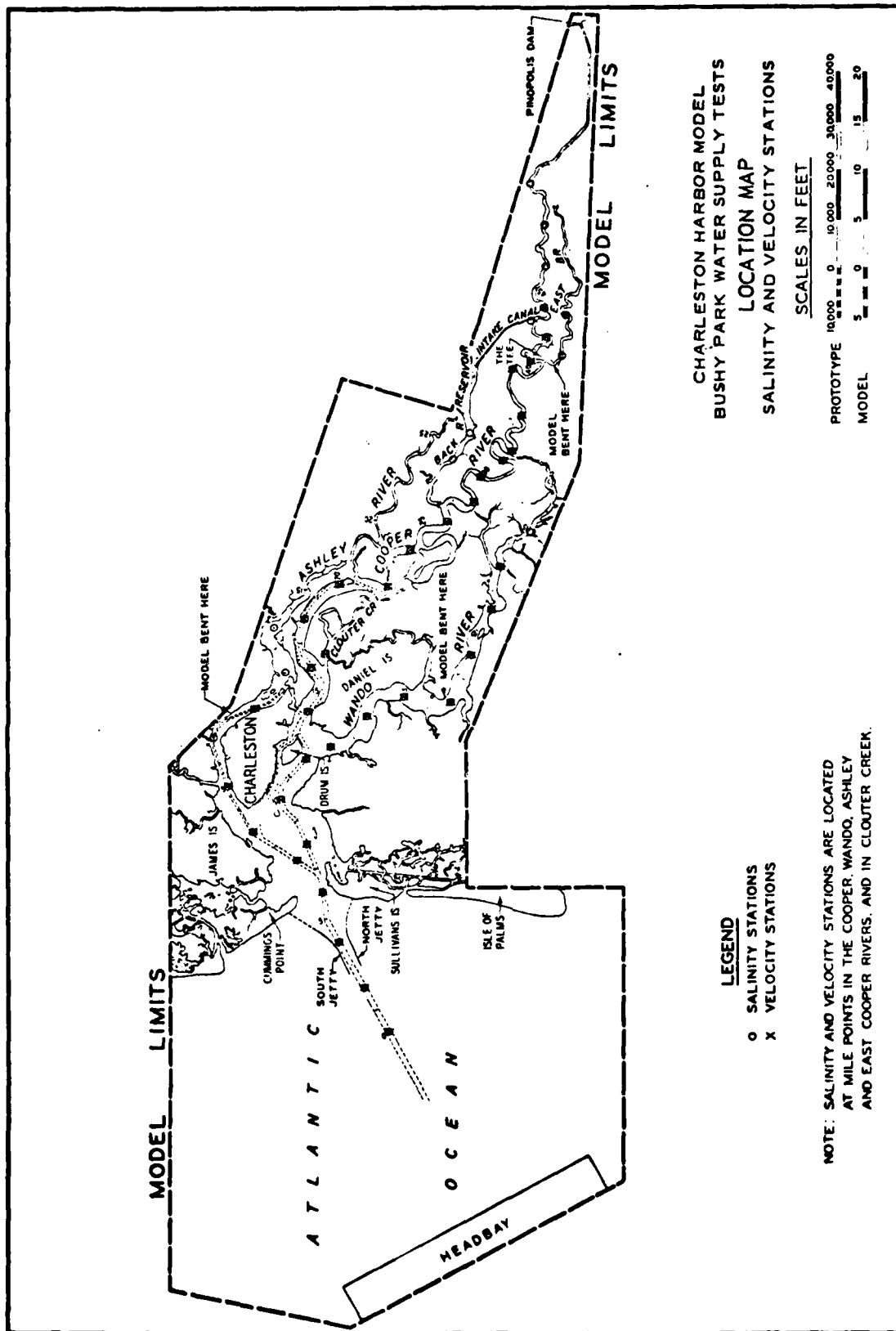

CHARLESTON HARBOR MODEL  
 BUSHY PARK WATER SUPPLY TESTS  
 LOCATION MAP  
 SALINITY AND VELOCITY STATIONS

SCALES IN FEET  
 PROTOTYPE 0 10,000 20,000 30,000 40,000  
 MODEL 5 10 15 20

LEGEND  
 o SALINITY STATIONS  
 x VELOCITY STATIONS

NOTE: SALINITY AND VELOCITY STATIONS ARE LOCATED AT MILE POINTS IN THE COOPER, WANDO, ASHLEY AND EAST COOPER RIVERS, AND IN CLOUTER CREEK.

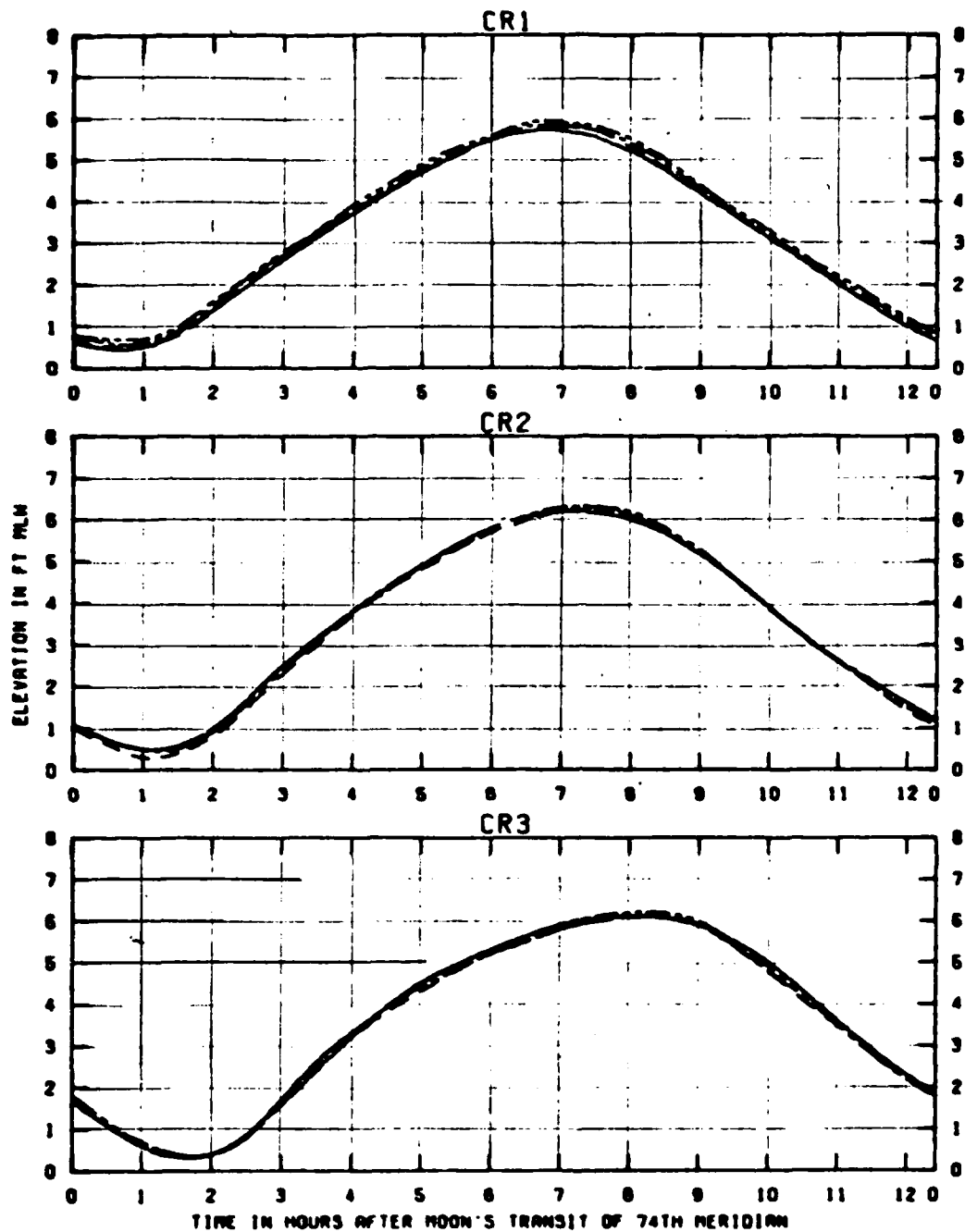

TEST CONDITIONS

OCEAN TIDE RANGE	5.4 FT
OCEAN SALINITY (TOTAL SALT)	30.0 PPT
BUSHY PARK COMBINED WITHDIAMALS	1150 CFS
ASHLEY RIVER 261 CFS	WANDO RIVER 82 CFS
COOPER RIVER -	VARIOUS WEEKLY HYDROGRAPHS

CHARLESTON HARBOR MODEL  
BUSHY PARK WATER SUPPLY TESTS

TIDAL HEIGHTS FOR  
WEEKLY HYDROGRAPH  
SCHEDULES A, B, C, AND D

LEGEND

Sch. A	—————
Sch. B	- - - - -
Sch. C	— . — . —
Sch. D	— . . — .

STATIONS  
CR1. CR2. AND CR3

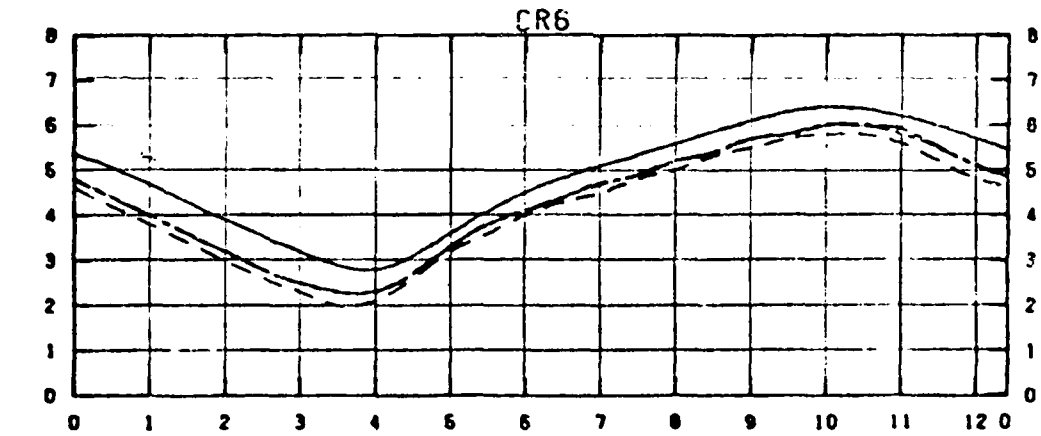
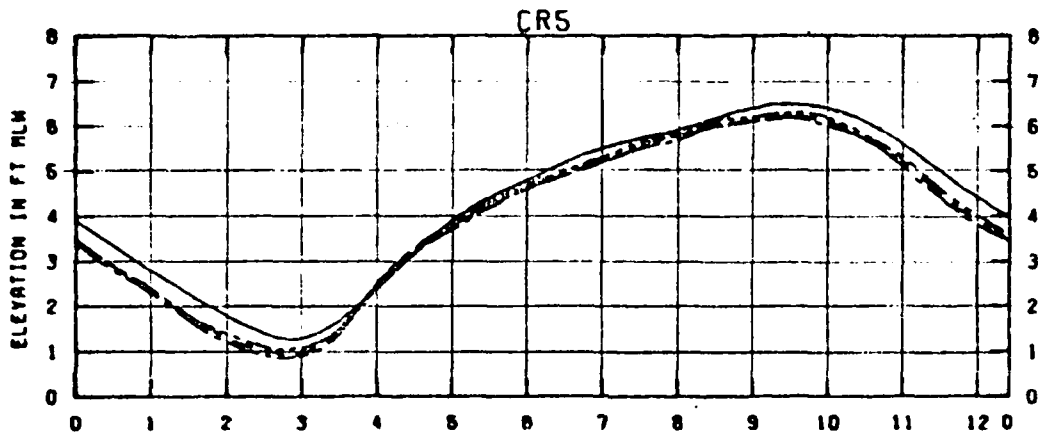
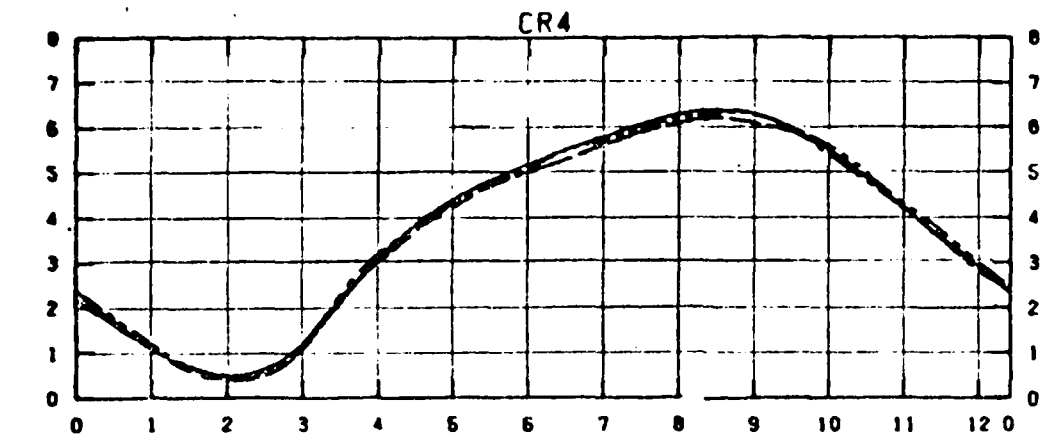

TIME IN HOURS AFTER MOON'S TRANSIT OF 74TH MERIDIAN

<b>TEST CONDITIONS</b>		CHARLESTON HARBOR MODEL
OCEAN TIDE RANGE	5.4 FT	BUSBY PARK WATER SUPPLY TESTS
OCEAN SALINITY (TOTAL SALT)	30.0 PPT	
BUSBY PARK COMBINED W/ HORAWALS	1150 CFS	<b>TIDAL HEIGHTS FOR</b>
ASHLEY RIVER 261 CFS	WANDO RIVER 82 CFS	<b>WEEKLY HYDROGRAPH</b>
COOPER RIVER -	VARIOUS WEEKLY HYDROGRAPHS	<b>SCHEDULES A, B, C, AND D</b>
<b>LEGEND</b>		
Sch. A	—————	<b>STATIONS</b>
Sch. B	- - - - -	CR4, CR5, AND CR6
Sch. C	- . . - .	
Sch. D	- . . . -	

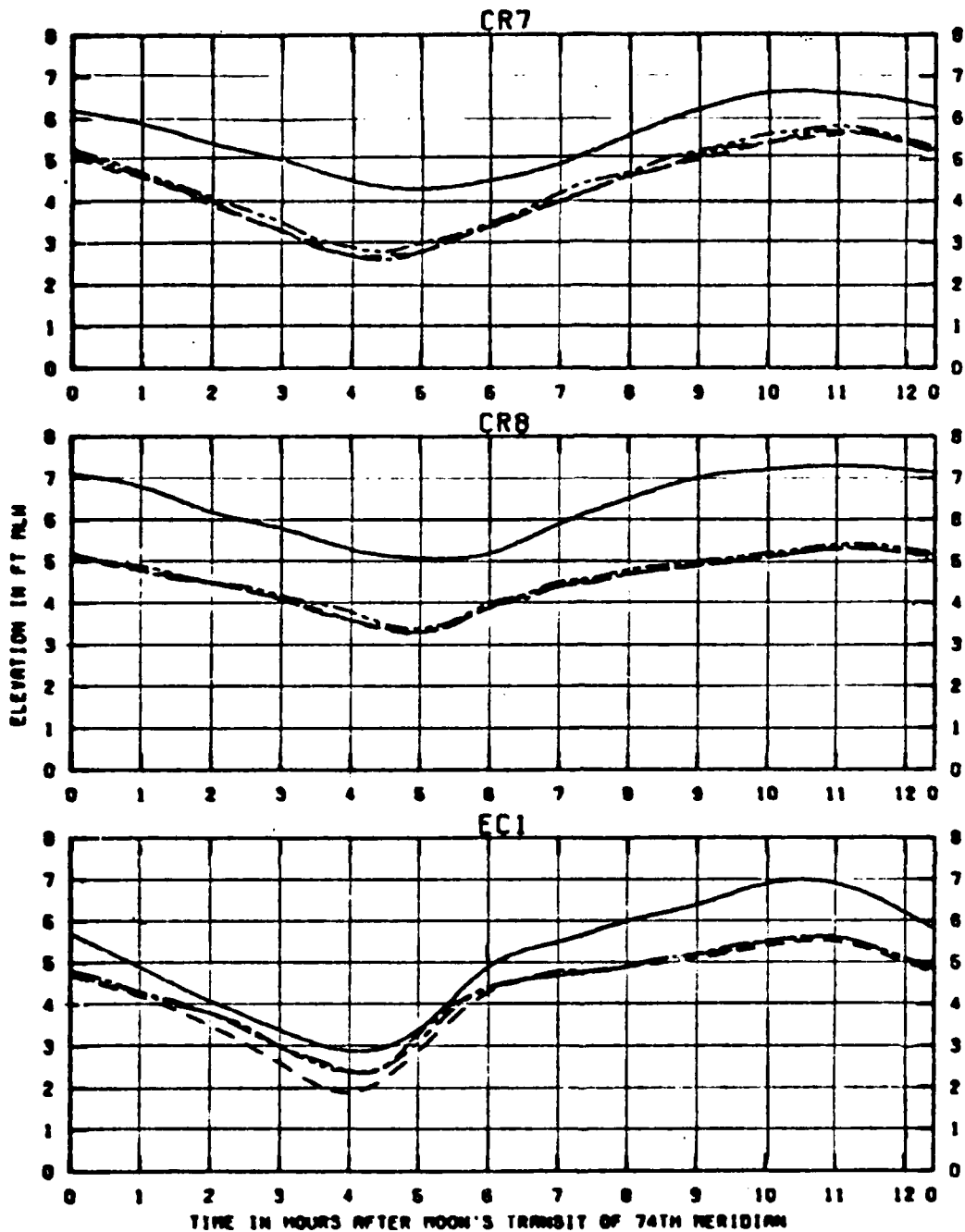

TEST CONDITIONS

OCEAN TIDE RANGE	5.4 FT
OCEAN SALINITY (TOTAL SALT)	30.0 PPT
BUSBY PARK COMBINED WITHDRAWALS	1150 CFS
ASHLEY RIVER 28. CFS	WANDO RIVER 82 CFS
COOPER RIVER -	VARIOUS WEEKLY HYDROGRAPHS

CHARLESTON HARBOR MODEL  
BUSBY PARK WATER SUPPLY TESTS

TIDAL HEIGHTS FOR  
WEEKLY HYDROGRAPH  
SCHEDULES A, B, C, AND D

LEGEND

Sch. A	—————
Sch. B	- - - - -
Sch. C	- . . . -
Sch. D	- - - - -

STATIONS  
CR7, CR8, AND EC1

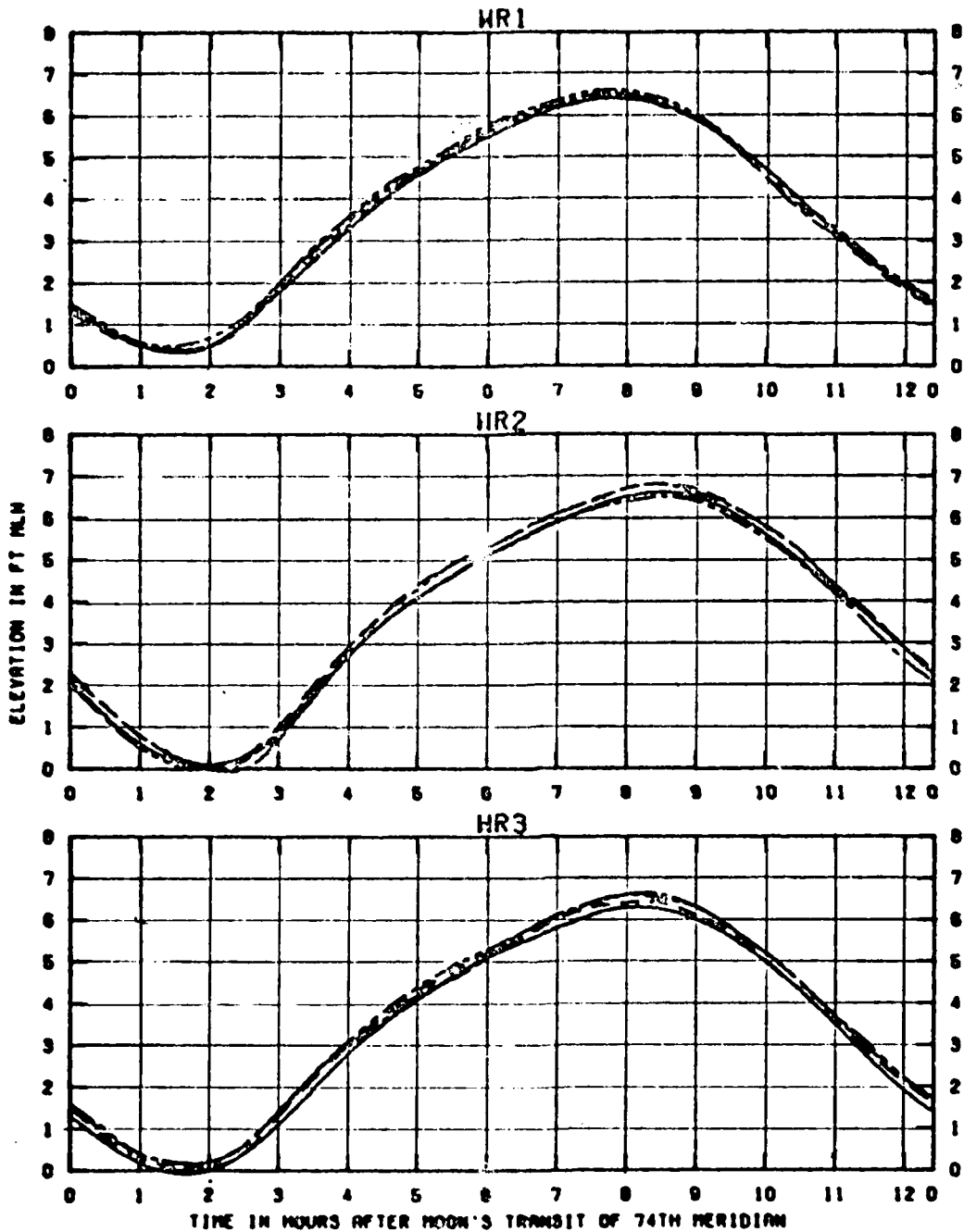

TEST CONDITIONS  
 OCEAN TIDE RANGE 5.4 FT  
 OCEAN SALINITY (TOTAL SALT) 30.0 PPT  
 BUSHY PARK COMBINED WITHDRAWS 1150 CFS  
 ASHLEY RIVER 281 CFS WANDO RIVER 82 CFS  
 COOPER RIVER - VARIOUS WEEKLY HYDROGRAPHS

CHARLESTON HARBOR MODEL  
 BUSHY PARK WATER SUPPLY TESTS  
 TIDAL HEIGHTS FOR  
 WEEKLY HYDROGRAPH  
 SCHEDULES A, B, C, AND D

LEGEND  
 Sch. A ————  
 Sch. B - - - -  
 Sch. C — . —  
 Sch. D — . . —

STATIONS  
 HR1, HR2, AND HR3

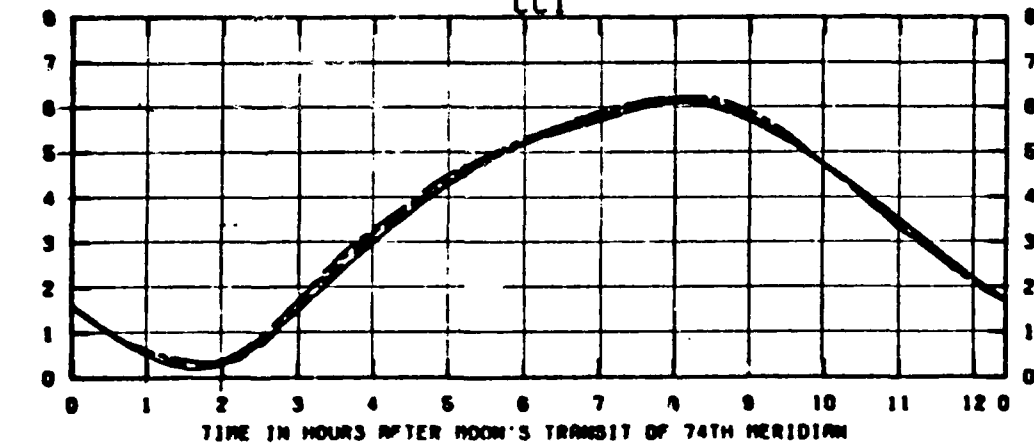
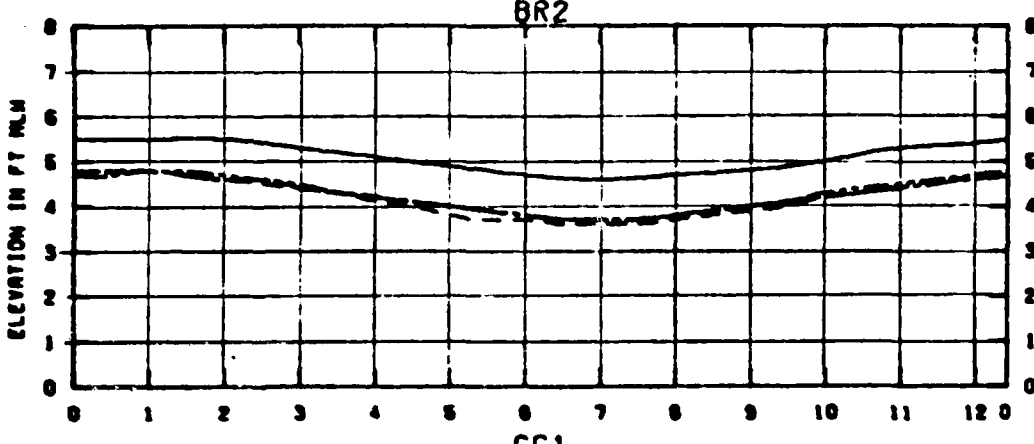
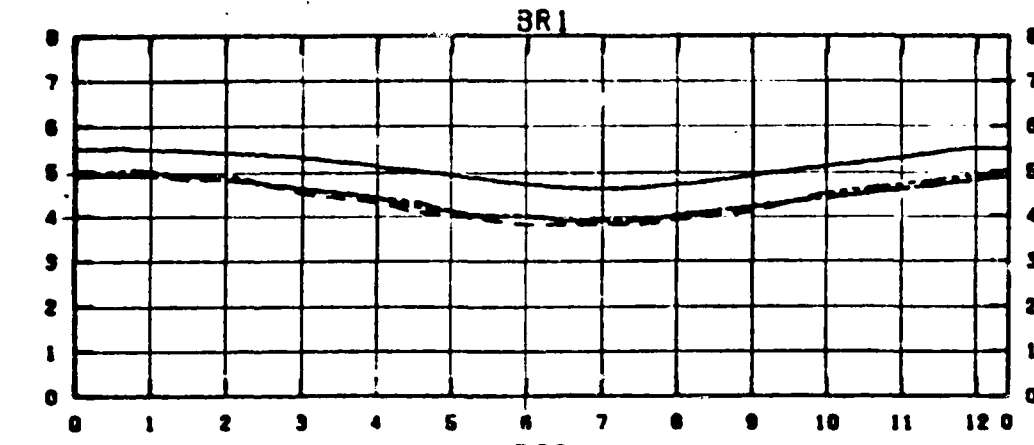

TEST CONDITIONS

OCEAN TIDE RANGE	8.4 FT
OCEAN SALINITY (TOTAL SALT)	30.0 PPT
BUSHY PARK COMBINED WITHOROWALS	1160 CFS
ASHLEY RIVER 261 CFS	WANDO RIVER 62 CFS
COOPER RIVER -	VARIOUS WEEKLY HYDROGRAPHS

CHARLESTON HARBOR MODEL  
BUSHY PARK WATER SUPPLY TESTS

TIDAL HEIGHTS FOR  
WEEKLY HYDROGRAPH  
SCHEDULES A, B, C, AND D

STATIONS  
BR1, BR2, AND CC1

LEGEND

Sch. A	—————
Sch. B	- - - - -
Sch. C	— . . —
Sch. D	— . . . —

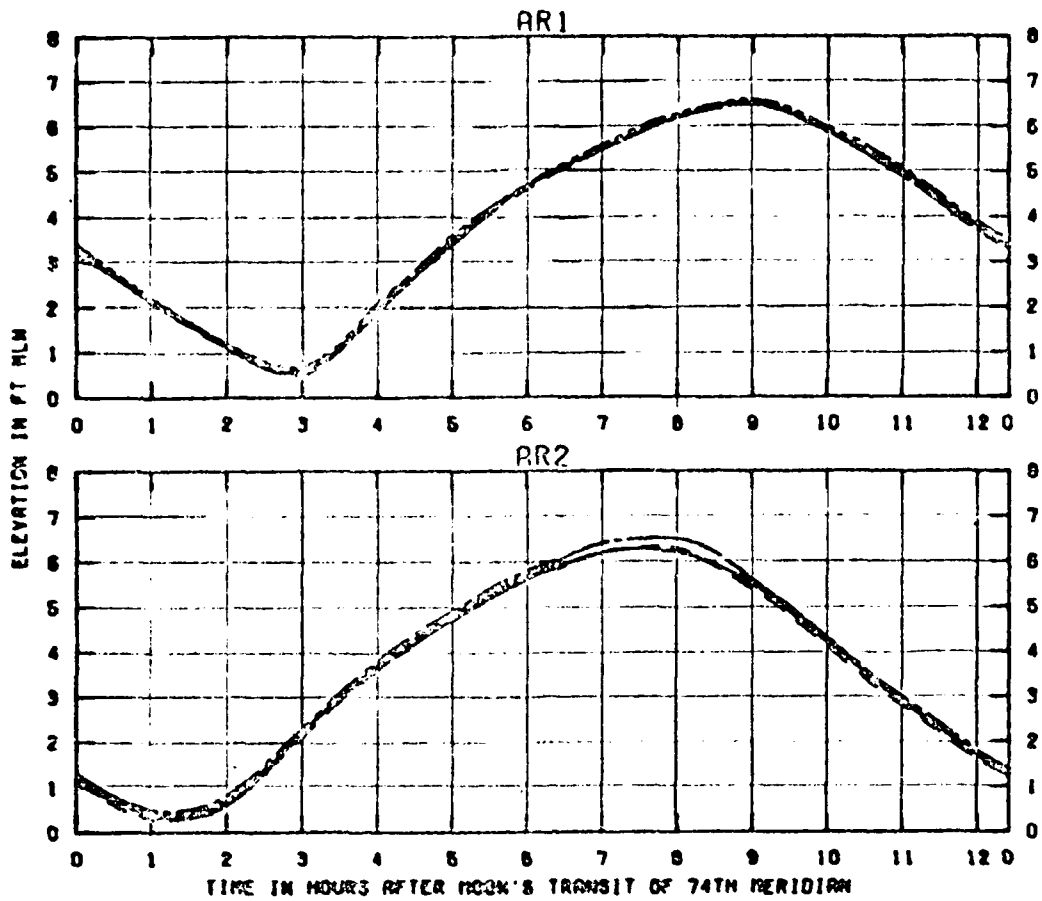

TEST CONDITIONS  
 OCEAN TIDE RANGE 6.4 FT  
 OCEAN SALINITY (TOTAL SOLT) 30.0 PPT  
 BUSHY PARK COMBINED WITHDRAWALS 1160 CFS  
 ROSSLEY RIVER 281 CFS WAGOOD RIVER 82 CFS  
 COOPER RIVER - VARIOUS WEEKLY HYDROGRAPHS

CHARLESTON HARBOR MODEL  
 BUSHY PARK WATER SUPPLY TESTS

TIDAL HEIGHTS FOR  
 WEEKLY HYDROGRAPH  
 SCHEDULES A, B, C, AND D

LEGEND  
 Sch. A —————  
 Sch. B - - - - -  
 Sch. C - . - . -  
 Sch. D . . . . .

STATIONS  
 AR1 AND AR2

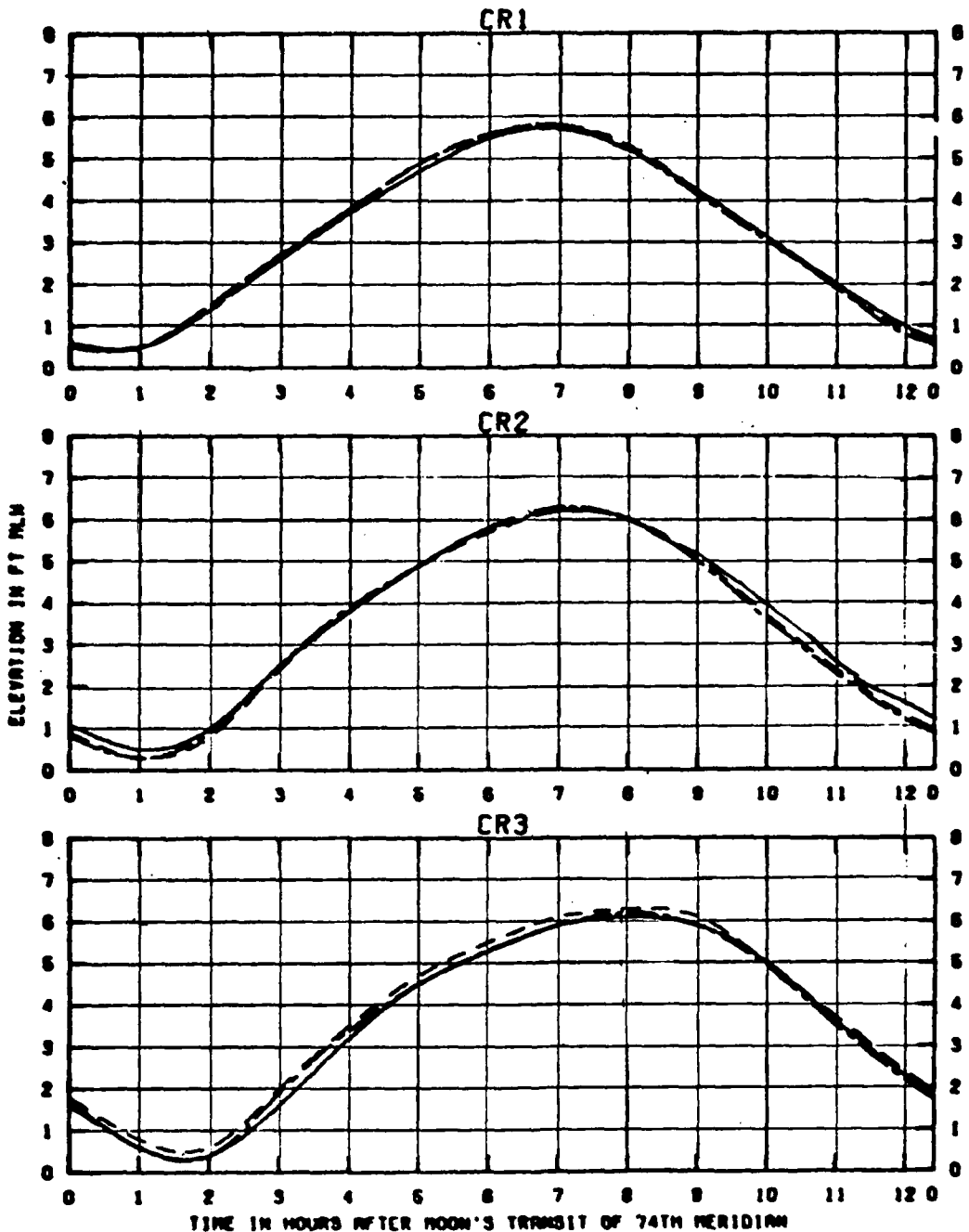

TEST CONDITIONS

OCEAN TIDE RANGE	6.4 FT
OCEAN SALINITY (TOTAL SALT)	30.0 PPT
BUSHY PARK COMBINED WITHORDALS	1150 CFS
ASHLEY RIVER 261 CFS	WANDO RIVER 82 CFS
COOPER RIVER -	VARIOUS WEEKLY HYDROGRAPHS

CHARLESTON HARBOR MODEL  
 BUSHY PARK WATER SUPPLY TESTS  
 TIDAL HEIGHTS FOR  
 WEEKLY HYDROGRAPH  
 SCHEDULES A, E, AND BM

LEGEND

Sch. A	—————
Sch. E	- - - - -
Sch. BM	- . - . -

STATIONS  
 CR1, CR2, AND CR3

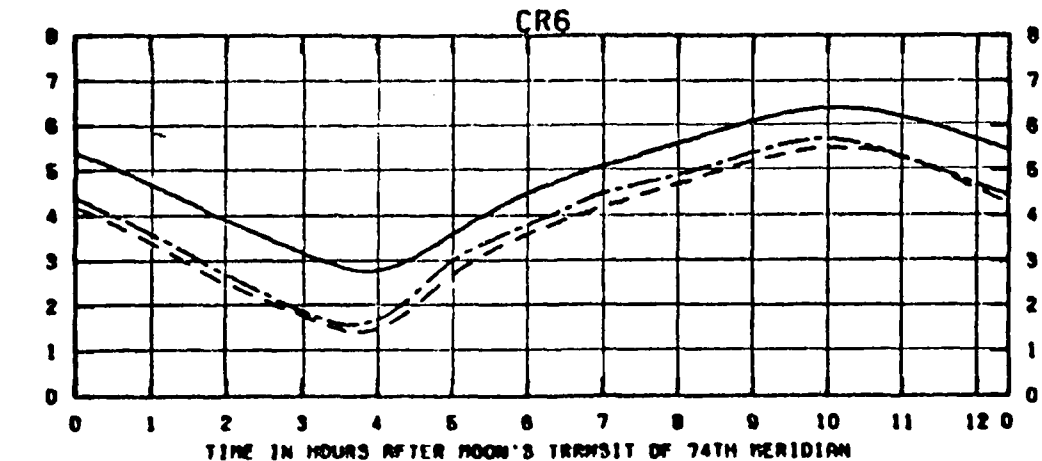
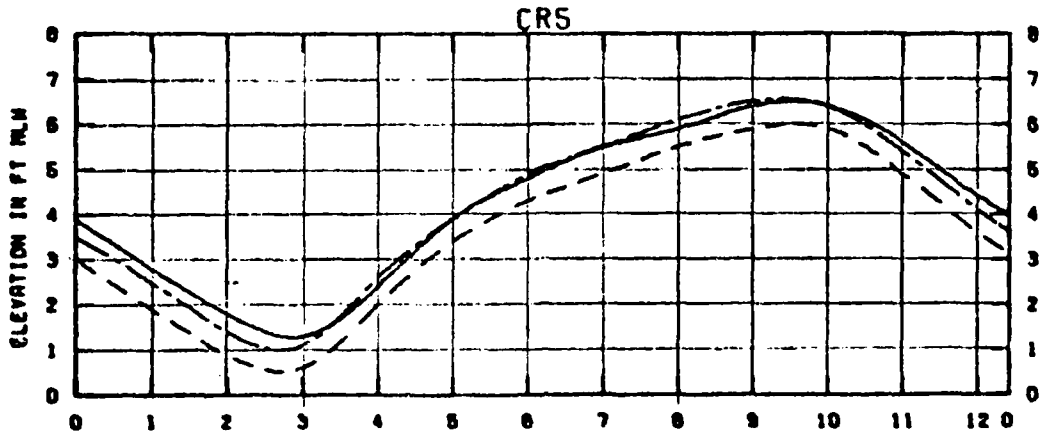
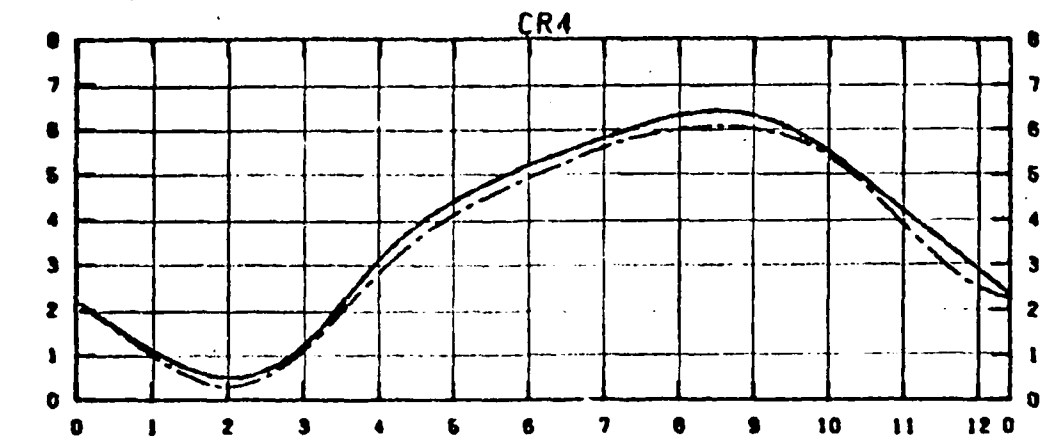

TEST CONDITIONS

OCEAN TIDE RANGE	6.4 FT
OCEAN SALINITY (TOTAL SALT)	30.0 PPT
BUSHY PARK COMBINED WITHDRAWALS	1160 CFS
ASHLEY RIVER 261 CFS	WYDOD RIVER 82 CFS
COOPER RIVER -	VARIOUS WEEKLY HYDROGRAPHS

CHARLESTON HARBOR MODEL  
 BUSHY PARK WATER SUPPLY TESTS  
 TIDAL HEIGHTS FOR  
 WEEKLY HYDROGRAPH  
 SCHEDULES A, E, AND BM

LEGEND

Sch. A	—————
Sch. E	- - - - -
Sch. BM	- . - . -

STATIONS  
 CR4, CR5, AND CR6

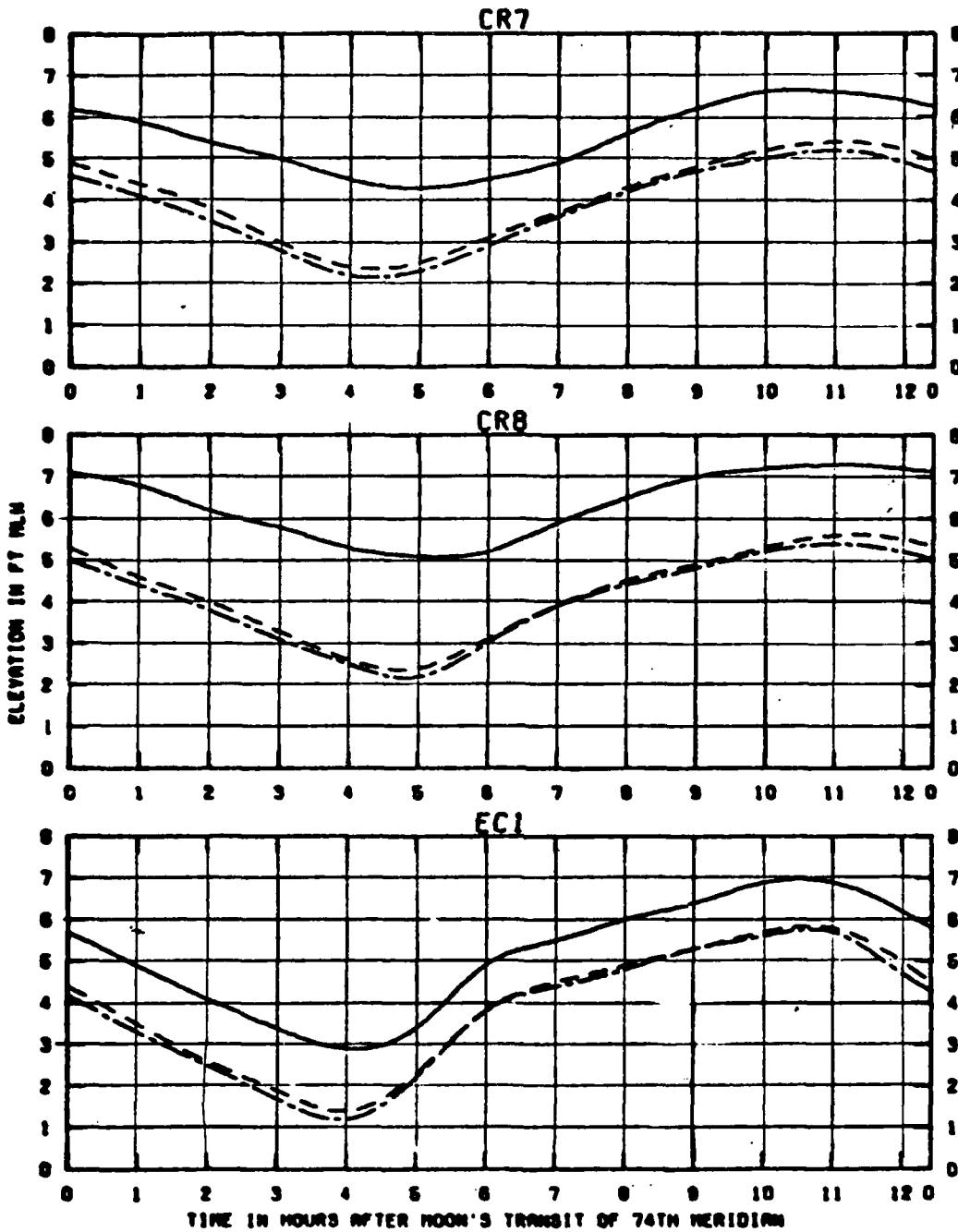

**TEST CONDITIONS**

OCEAN TIDE RANGE	6.4 FT
OCEAN SALINITY (TOTAL SALT)	30.0 PPT
BUSHY PARK COMBINED WITHDRAWALS	1160 CFS
ASHLEY RIVER 261 CFS	WYCKO RIVER 82 CFS
COOPER RIVER -	VARIOUS WEEKLY HYDROGRAPHS

**CHARLESTON HARBOR MODEL  
BUSHY PARK WATER SUPPLY TESTS**

**TIDAL HEIGHTS FOR  
WEEKLY HYDROGRAPH  
SCHEDULES A, E, AND BM**

**LEGEND**

Sch. A ————  
 Sch. B - - - -  
 Sch. BM - . - .

**STATIONS  
CR7, CR8, AND EC1**

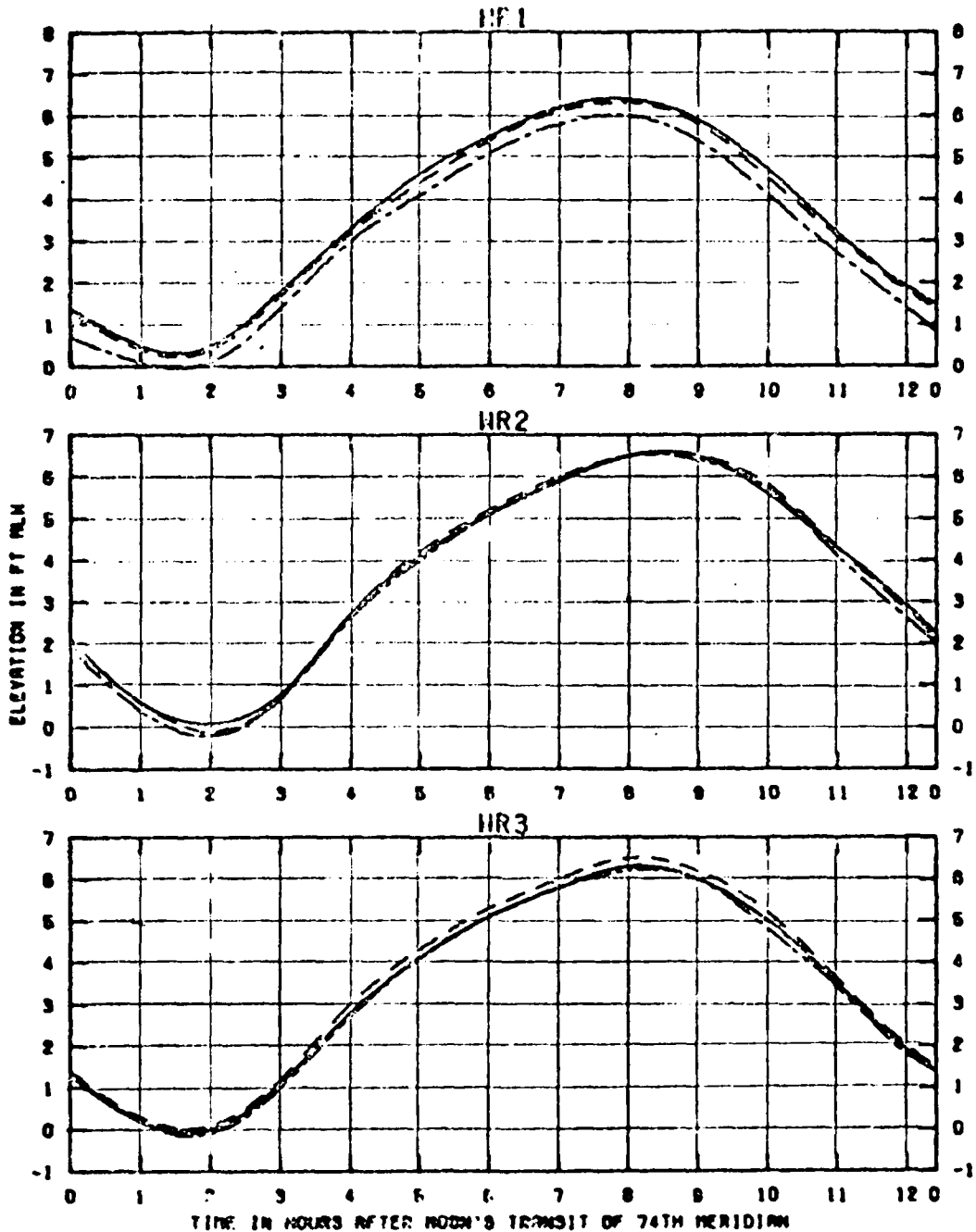

TEST CONDITIONS

OCEAN TIDE RANGE	6.4 FT
OCEAN SALINITY (TOTAL SALTY)	30.3 PPT
BUSBY PRAK COASTED MITERGABLE	1180 CFS
ROBLEY RIVER 261 CFS	WAGDO RIVER 02 CFS
COOPER RIVER -	VARIOUS WEEKLY HYDROGRAPHS

CHARLESTON HARBOR MODEL  
 BUSBY PRAK WATER SUPPLY TESTS  
 TIDAL HEIGHTS FOR  
 WEEKLY HYDROGRAPH  
 SCHEDULES A, E, AND BM

LEGEND

Sch. A	—————
Sch. E	- - - - -
Sch. BM	- · - · -

STATIONS  
 MR1, MR2, AND MR3

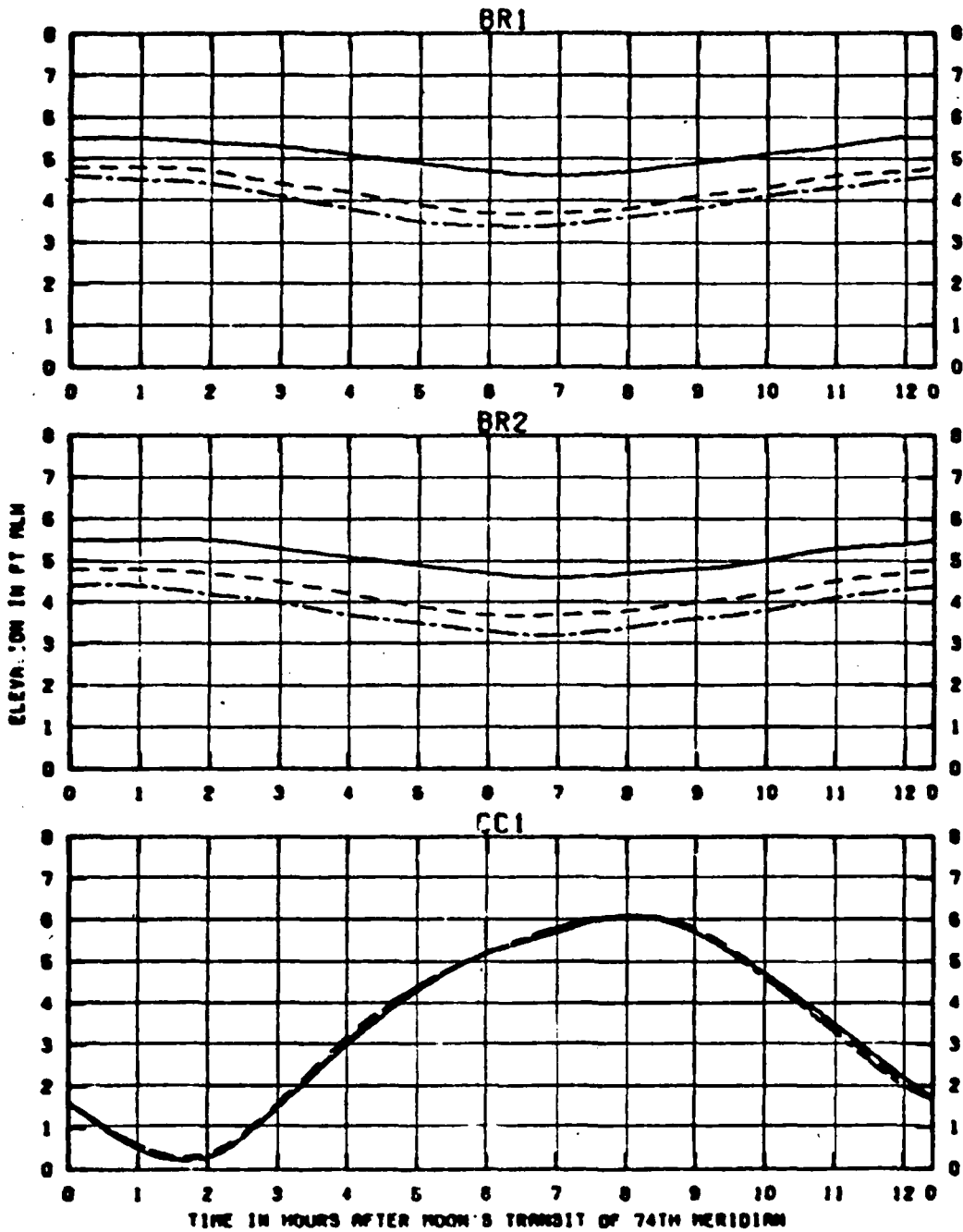

TEST CONDITIONS  
 OCEAN TIDE RANGE 5.4 FT  
 OCEAN SALINITY (TOTAL SALT) 30.0 PPT  
 BUSHY PARK COMBINED WITHDRAWALS 1150 CFS  
 RANLEY RIVER 281 CFS MARCO RIVER 82 CFS  
 COPPER RIVER - VARIOUS WEEKLY HYDROGRAPHS

CHARLESTON HARBOR WOOD  
 BUSHY PARK WATER SUPPLY TESTS

TIDAL HEIGHTS FOR  
 WEEKLY HYDROGRAPH  
 SCHEDULES A, E, AND BM

LEGEND  
 Sch. A ———  
 Sch. E - - - -  
 Sch. BM - . . .

STATIONS  
 BR1, BR2, AND CCI

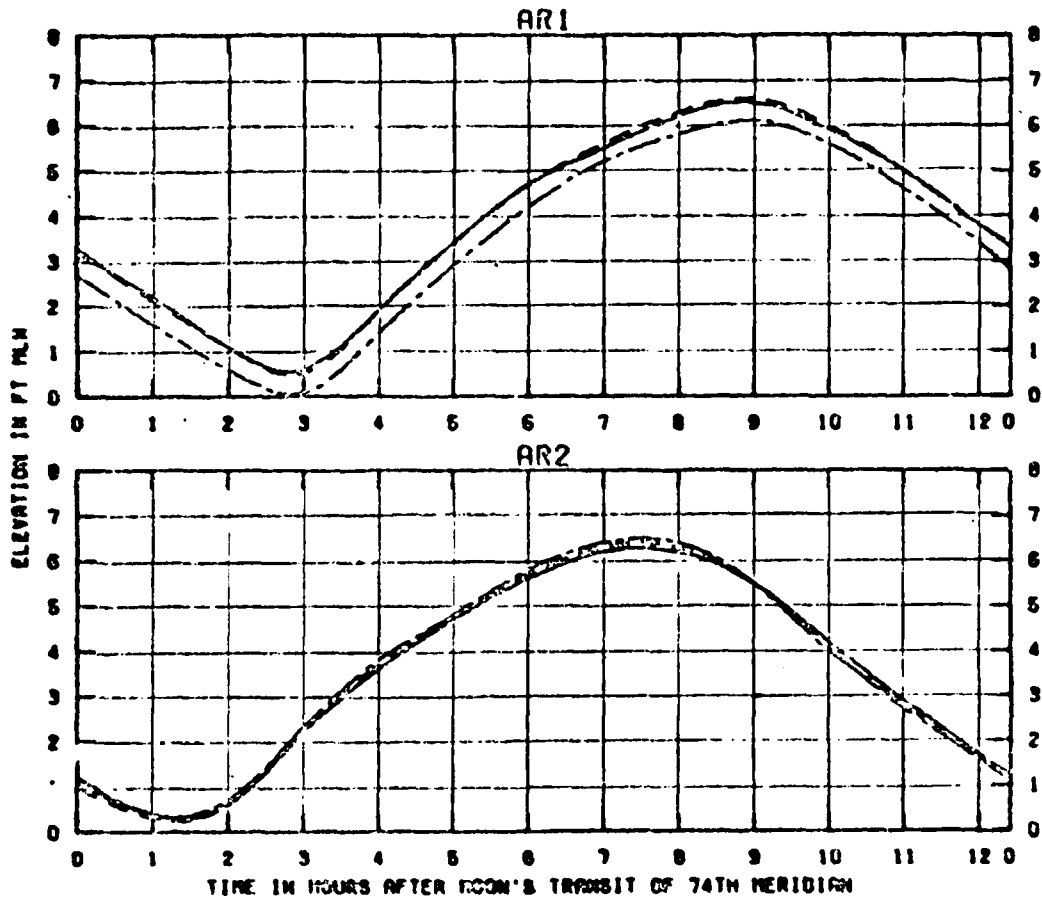

TEST CONDITIONS  
 OCEAN TIDE RANGE 6.4 FT  
 OCEAN SALINITY (TOTAL) 30.71 30.0 PPT  
 BUSBY POND COASTAL HYDROGRAPHS 1150 CFS  
 ASHLEY RIVER 281 CFS WASS RIVER 62 CFS  
 COPPER RIVER - VARIOUS WEEKLY HYDROGRAPHS

CHARLESTON HARBOR MODEL  
 BUSBY POND WATER SUPPLY TESTS

TIDAL HEIGHTS FOR  
 WEEKLY HYDROGRAPH  
 SCHEDULES A, E, AND BM

STATIONS  
 AR1 AND AR2

LEGEND  
 Sch. A ———  
 Sch. B - - - -  
 Sch. BM - . - .

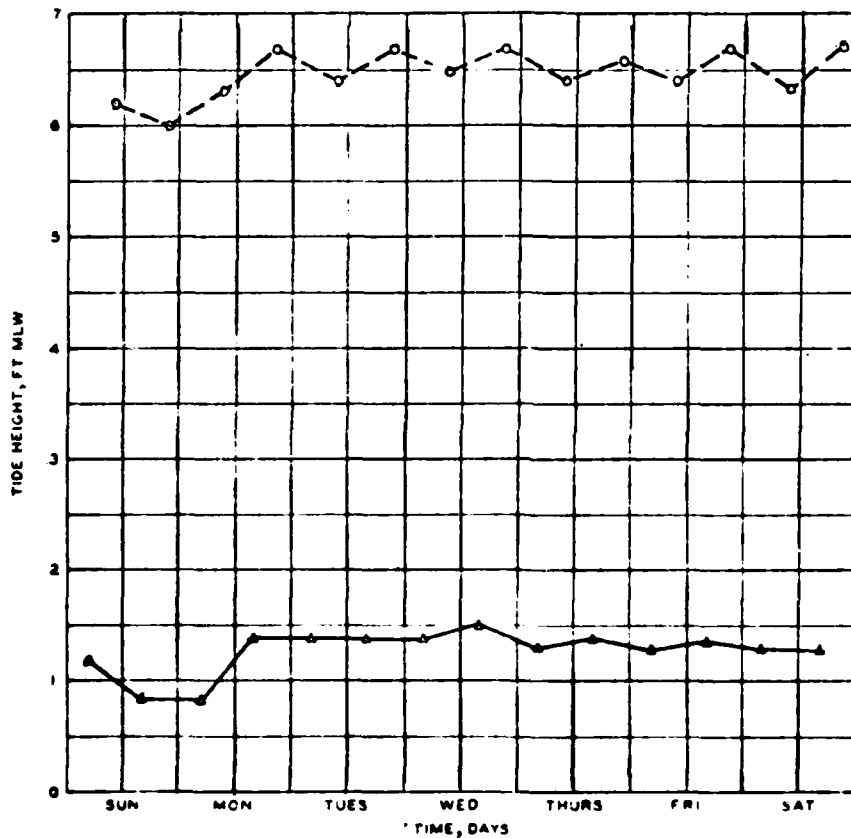
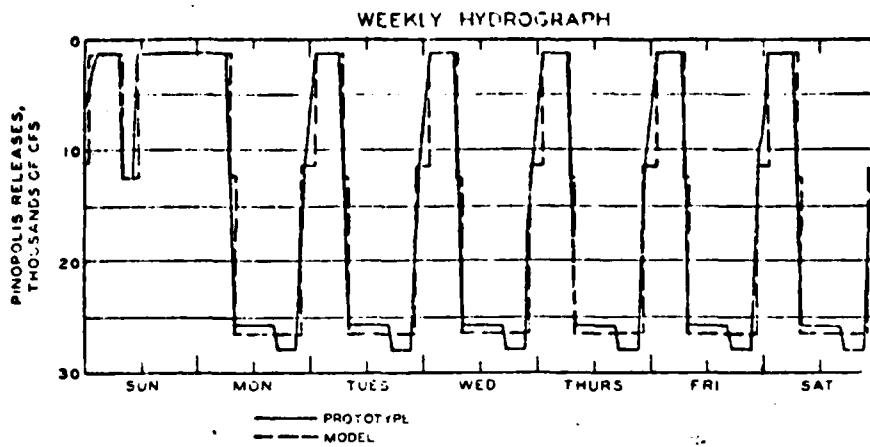

**TEST CONDITIONS**

OCEAN TIDE RANGE 5.4 FT  
 OCEAN SALINITY (TOTAL SALT) 30,000 PPM  
 ASHLEY RIVER 281 CFS WANDO RIVER R2 CFS  
 BUSHY PARK COMBINED WITHDRAWALS 1150 CFS  
 COOPER RIVER FLOW 15,000 CFS SCHEDULE A

○ — ○ HIGH WATER  
 ● — ● LOW WATER

**CHARLESTON HARBOR MODEL  
 BUSHY PARK WATER SUPPLY TESTS**

**EFFECTS OF  
 SCHEDULE A WEEKLY HYDROGRAPH  
 ON MAXIMUM AND MINIMUM  
 TIDE HEIGHTS  
 STATION CR-5**

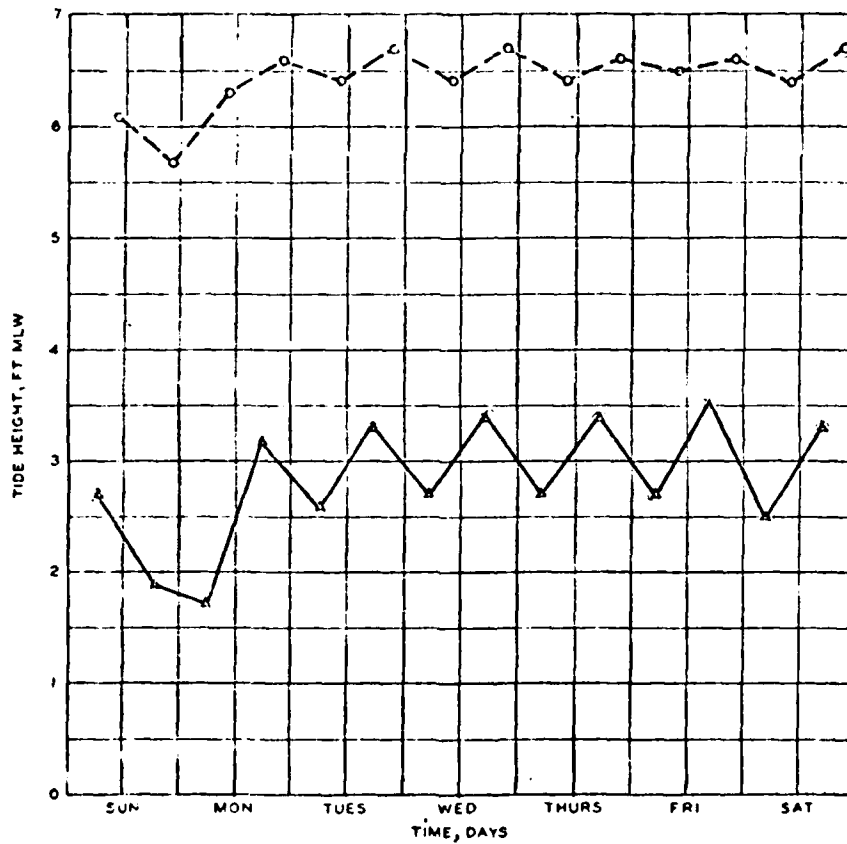
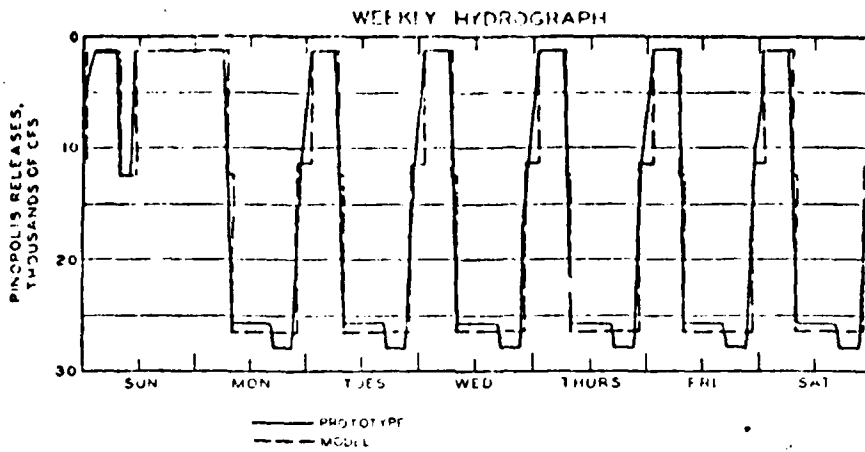

TEST CONDITIONS

OCEAN TIDE RANGE 5.4 FT  
 OCEAN SALINITY (TOTAL SALT) 30000 PPM  
 ASHLEY RIVER 261 CFS WANDU RIVER 81 CFS  
 BUSHY PARK COMBINED WITHDRAWALS 1150 CFS  
 COOPER RIVER FLOW 15,000 CFS SCHEDULE A

○ — — — — — HIGH WATER  
 — — — — — △ — — — — — LOW WATER

CHARLESTON HARBOR VORDEL  
 BUSHY PARK WATER SUPPLY TESTS

EFFECTS OF  
 SCHEDULE A WEEKLY HYDROGRAPH  
 ON MAXIMUM AND MINIMUM  
 TIDE HEIGHTS  
 STATION CR-6

WEEKLY HYDROGRAPH

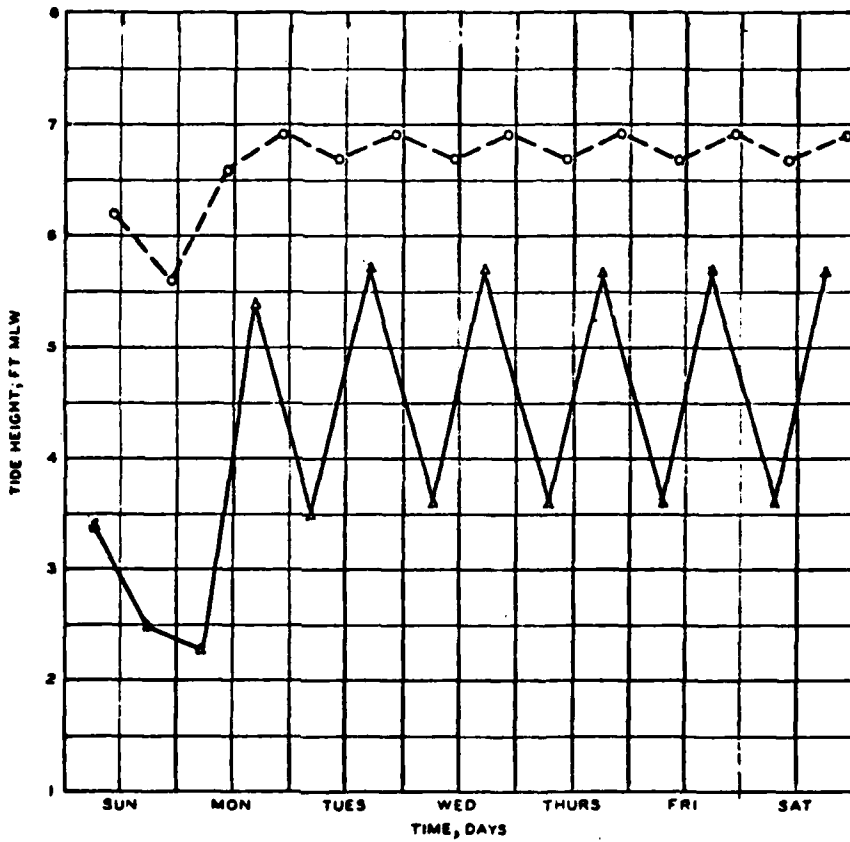
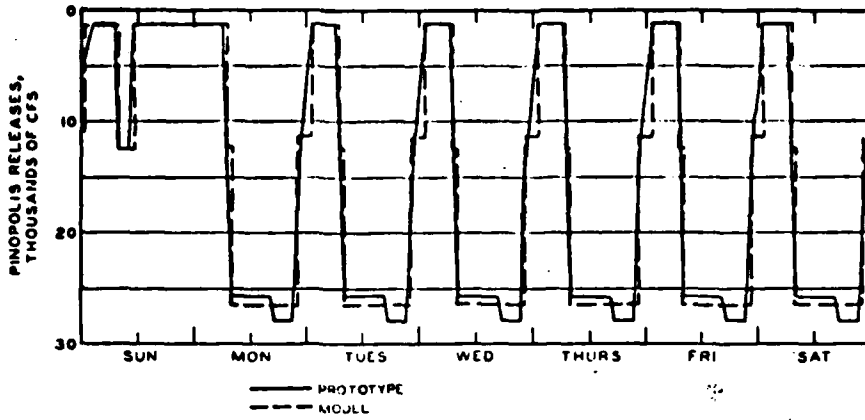

**TEST CONDITIONS**  
 OCEAN TIDE RANGE 5.4 FT  
 OCEAN SALINITY (TOTAL SALT) 30,000 PPM  
 ASHLEY RIVER 281 CFS WANDO RIVER 82 CFS  
 BUSHY PARK COMBINED WITHDRAWALS 1150 CFS  
 COOPER RIVER FLOW 15,000 CFS SCHEDULE A

○ — HIGH WATER  
 ▲ — LOW WATER

CHARLESTON HARBOR MODEL  
 BUSHY PARK WATER SUPPLY TESTS

EFFECTS OF  
 SCHEDULE A WEEKLY HYDROGRAPH  
 ON MAXIMUM AND MINIMUM  
 TIDE HEIGHTS  
 STATION CR-7

WEEKLY HYDROGRAPH

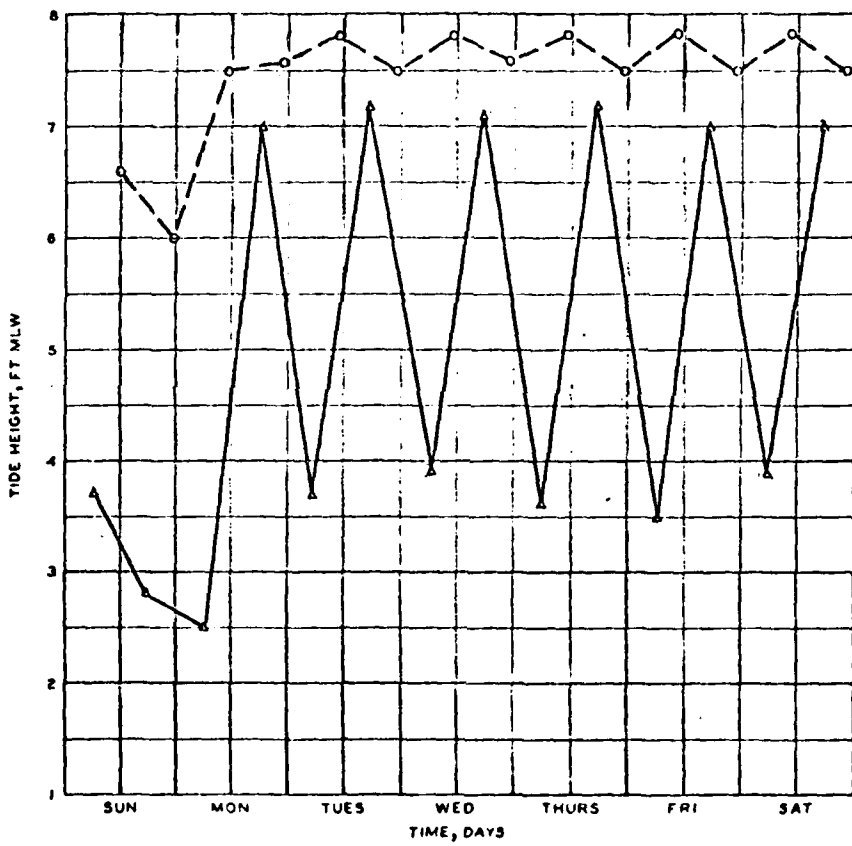
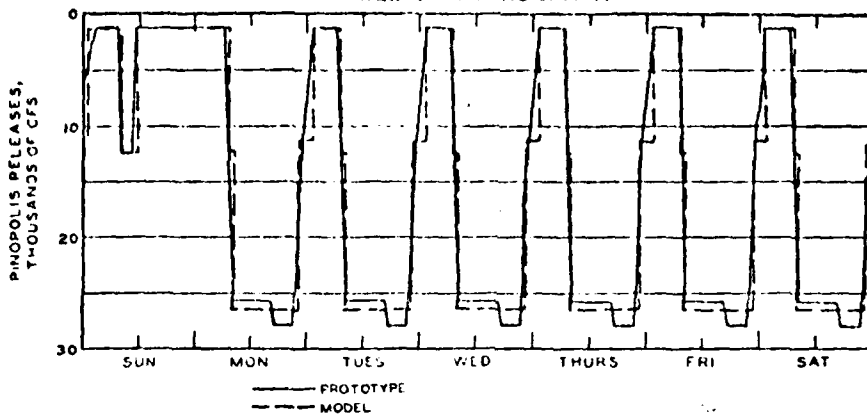

TEST CONDITIONS

OCEAN TIDE RANGE 5.4 FT  
 OCEAN SALINITY (TOTAL SALT) 30,000 PPM  
 ASHLEY RIVER 261 CFS WANDO RIVER 82 CFS  
 BUSHY PARK COMBINED WITHDRAWALS 1150 CFS  
 COOPER RIVER FLOW 15,000 CFS SCHEDULE A

○ — ○ HIGH WATER  
 ▲ — ▲ LOW WATER

CHARLESTON HARBOR MODEL  
 BUSHY PARK WATER SUPPLY TESTS

EFFECTS OF  
 SCHEDULE A WEEKLY HYDROGRAPH  
 ON MAXIMUM AND MINIMUM  
 TIDE HEIGHTS  
 STATION CR-6

WEEKLY HYDROGRAPH

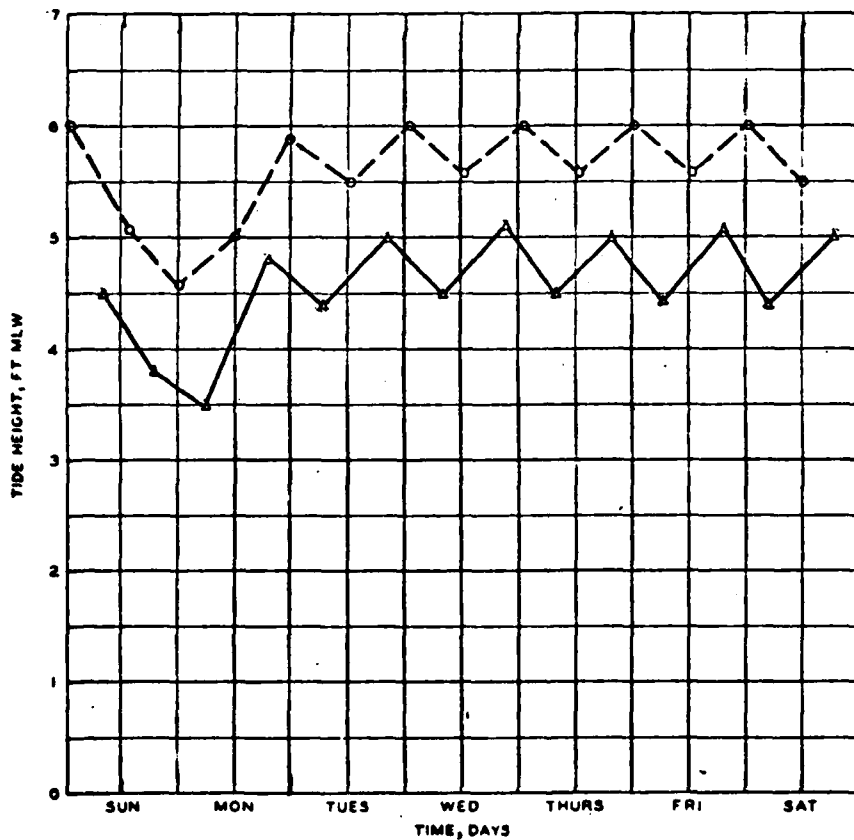
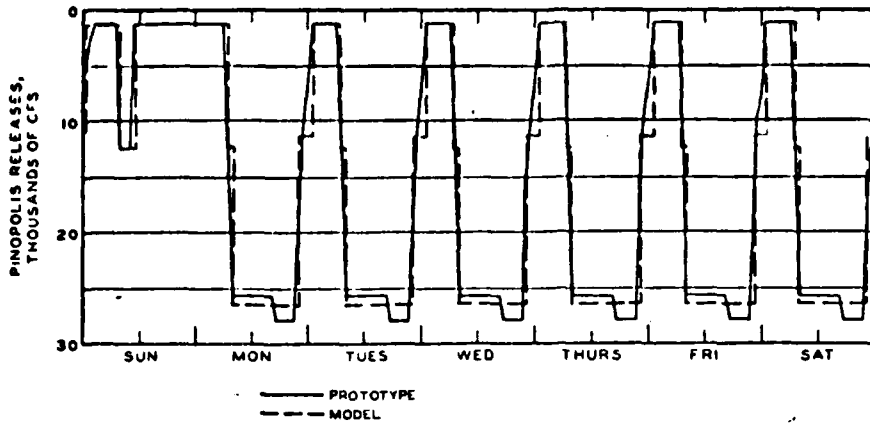

TEST CONDITIONS

OCEAN TIDE RANGE 5.4 FT  
 OCEAN SALINITY (TOTAL SALT) 30,000 PPM  
 ASHLEY RIVER 261 CFS WANDO RIVER 82 CFS  
 BUSHY PARK COMBINED WITHDRAWALS 1150 CFS  
 COOPER RIVER FLOW 15,000 CFS SCHEDULE A

○ — ○ HIGH WATER  
 — — — LOW WATER

CHARLESTON HARBOR MODEL  
 BUSHY PARK WATER SUPPLY TESTS

EFFECTS OF  
 SCHEDULE A WEEKLY HYDROGRAPH  
 ON MAXIMUM AND MINIMUM  
 TIDE HEIGHTS  
 STATION BR-1

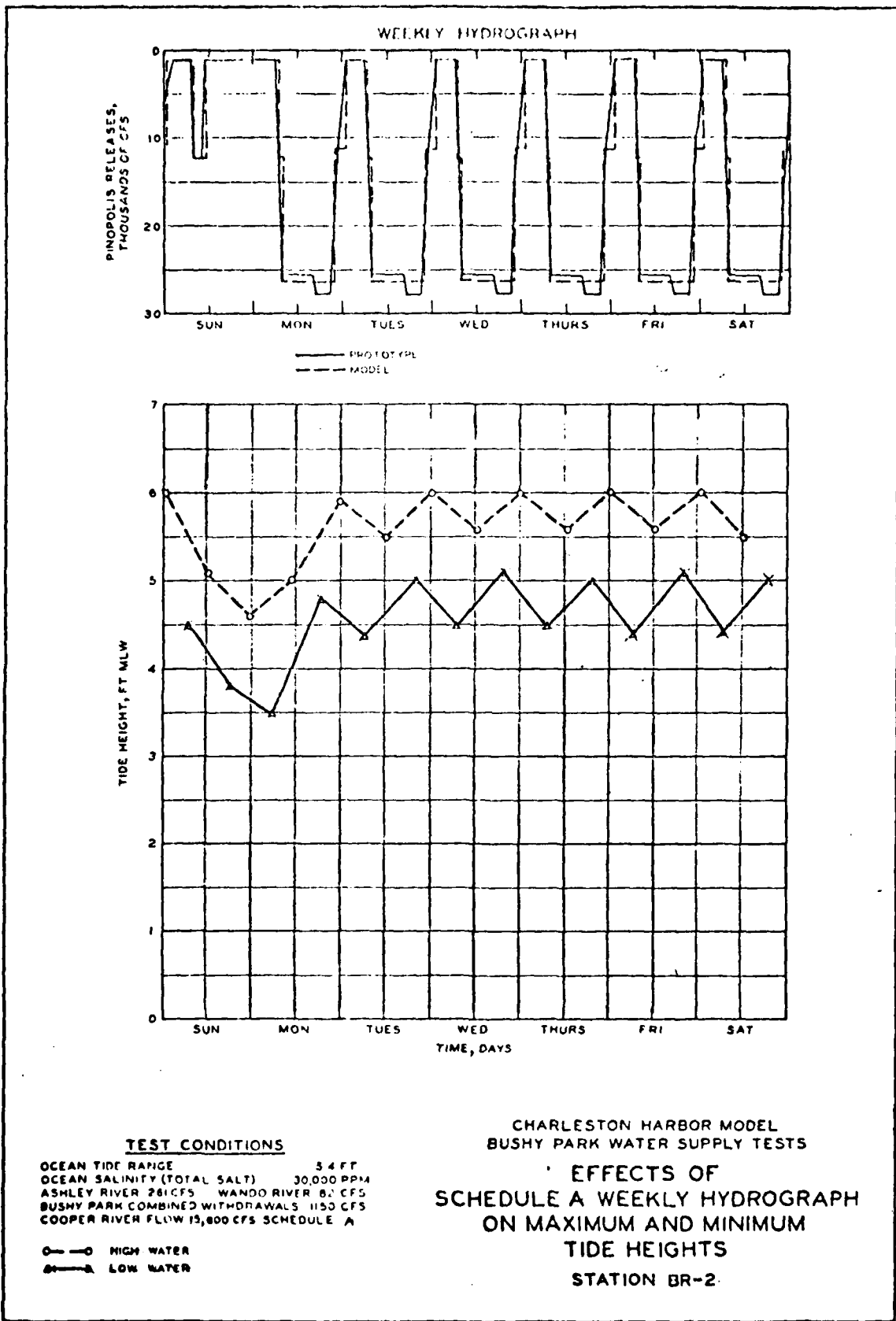

WEEKLY HYDROGRAPH

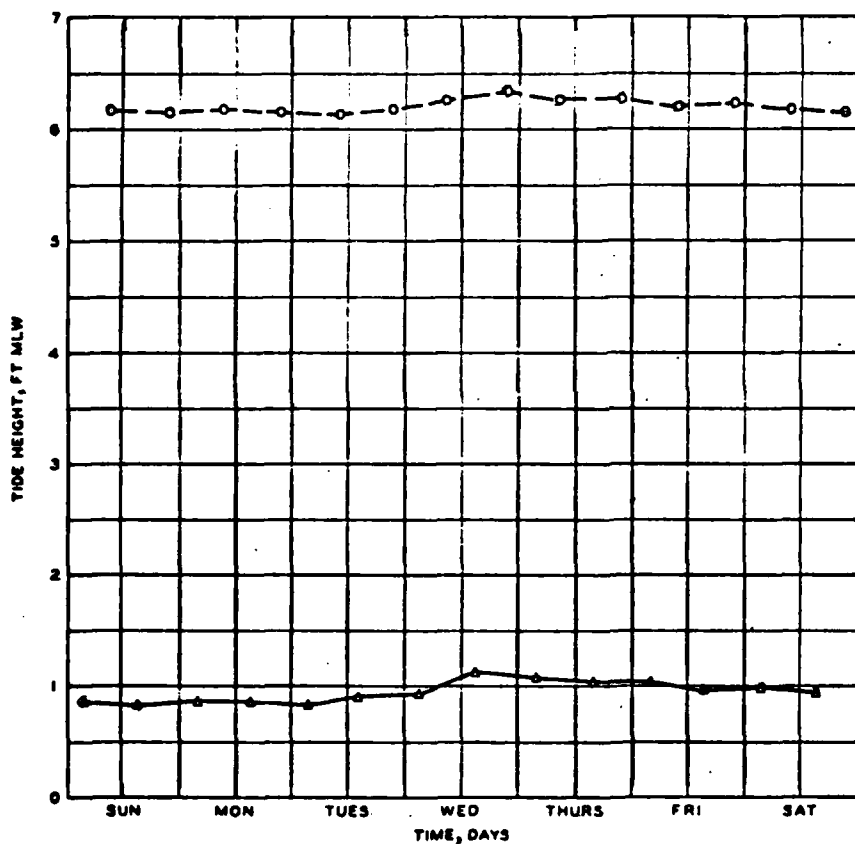
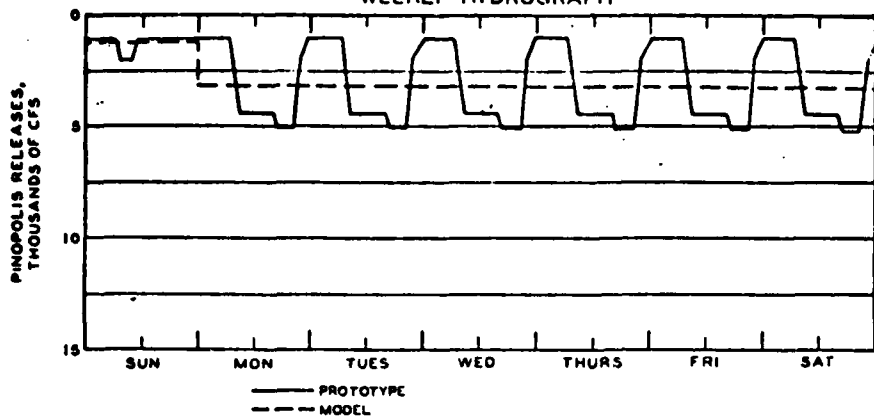

TEST CONDITIONS

OCEAN TIDE RANGE 5.4 FT  
 OCEAN SALINITY (TOTAL SALT) 30,000 PPM  
 ASHLEY RIVER 261 CFS WANDO RIVER 82 CFS  
 BUSHY PARK COMBINED WITHDRAWALS 1150 CFS  
 COOPER RIVER FLOW 3000 CFS SCHEDULE B

○ — ○ HIGH WATER  
 ● — ● LOW WATER

CHARLESTON HARBOR MODEL  
 BUSHY PARK WATER SUPPLY TESTS

EFFECTS OF  
 SCHEDULE B WEEKLY HYDROGRAPH  
 ON MAXIMUM AND MINIMUM  
 TIDE HEIGHTS  
 STATION CR-5

WEEKLY HYDROGRAPH

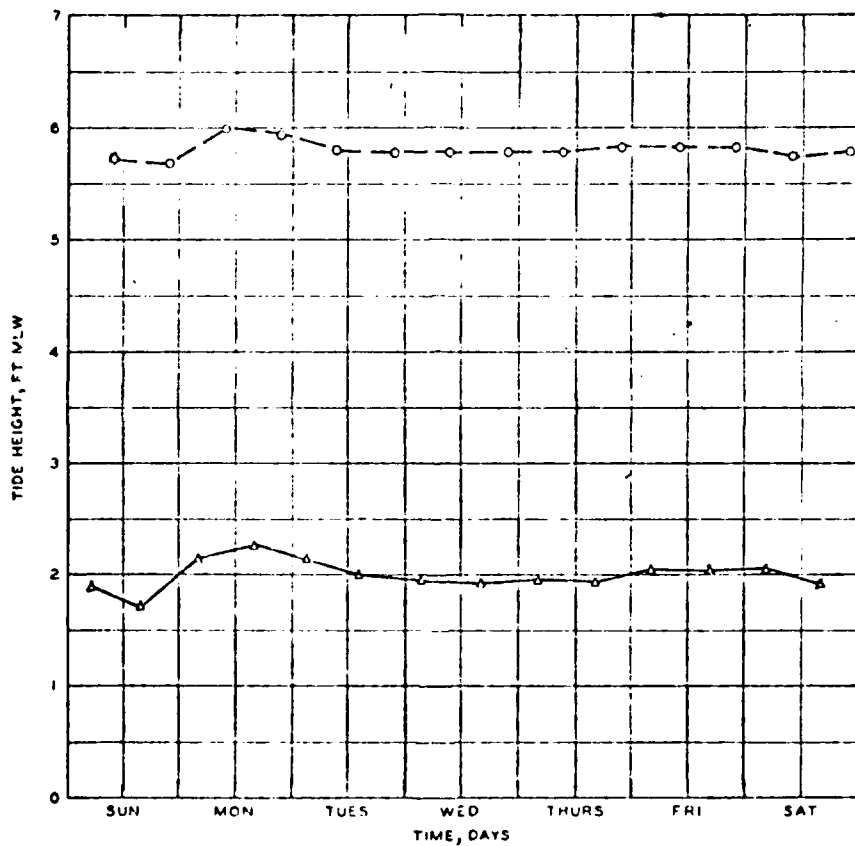
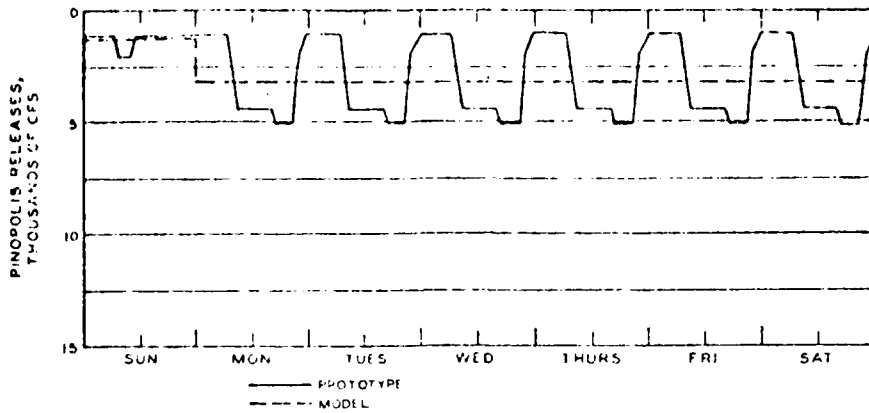

TEST CONDITIONS

OCEAN TIDE RANGE 5.4 FT  
 OCEAN SALINITY (TOTAL SALT) 30,000 PPM  
 ASHLEY RIVER 260 CFS WANCO RIVER 120 CFS  
 BUSHY PARK COMBINED WITHDRAWALS 1150 CFS  
 COOPER RIVER FLOW 3000 CFS SCHEDULE B

○ — ○ HIGH WATER  
 ▲ — ▲ LOW WATER

CHARLESTON HARBOR MODEL  
 BUSHY PARK WATER SUPPLY TESTS

EFFECTS OF  
 SCHEDULE B WEEKLY HYDROGRAPH  
 ON MAXIMUM AND MINIMUM  
 TIDE HEIGHTS  
 STATION CR-6

WEEKLY HYDROGRAPH

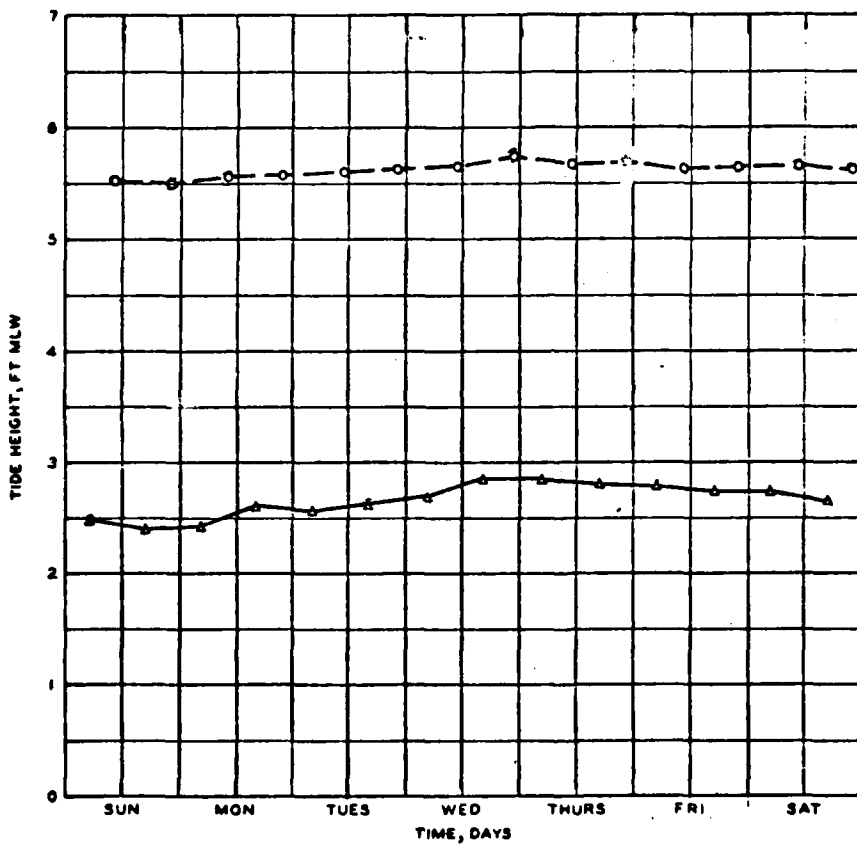
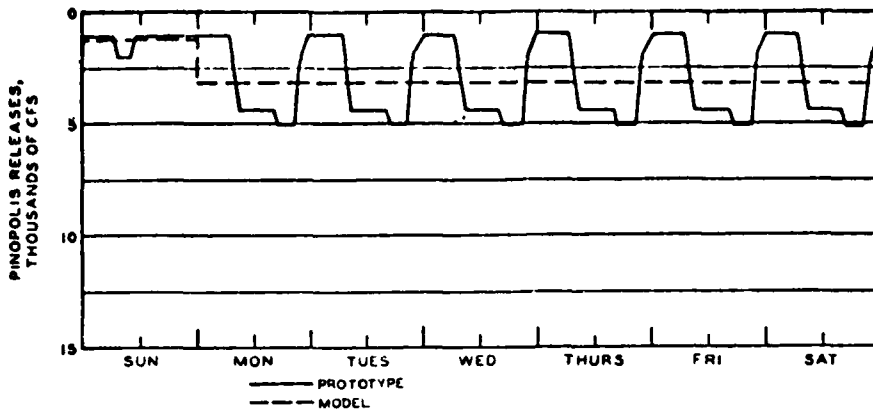

TEST CONDITIONS

OCEAN TIDE RANGE 5.4 FT  
 OCEAN SALINITY (TOTAL SALT) 30,000 PPM  
 ASHLEY RIVER 261 CFS WANDO RIVER 82 CFS  
 BUSHY PARK COMBINED WITHDRAWALS 1150 CFS  
 COOPER RIVER FLOW 3000 CFS SCHEDULE B

○—○ HIGH WATER  
 ▲—▲ LOW WATER

CHARLESTON HARBOR MODEL  
 BUSHY PARK WATER SUPPLY TESTS  
 EFFECTS OF  
 SCHEDULE B WEEKLY HYDROGRAPH  
 ON MAXIMUM AND MINIMUM  
 TIDE HEIGHTS  
 STATION CR-7

WEEKLY HYDROGRAPH

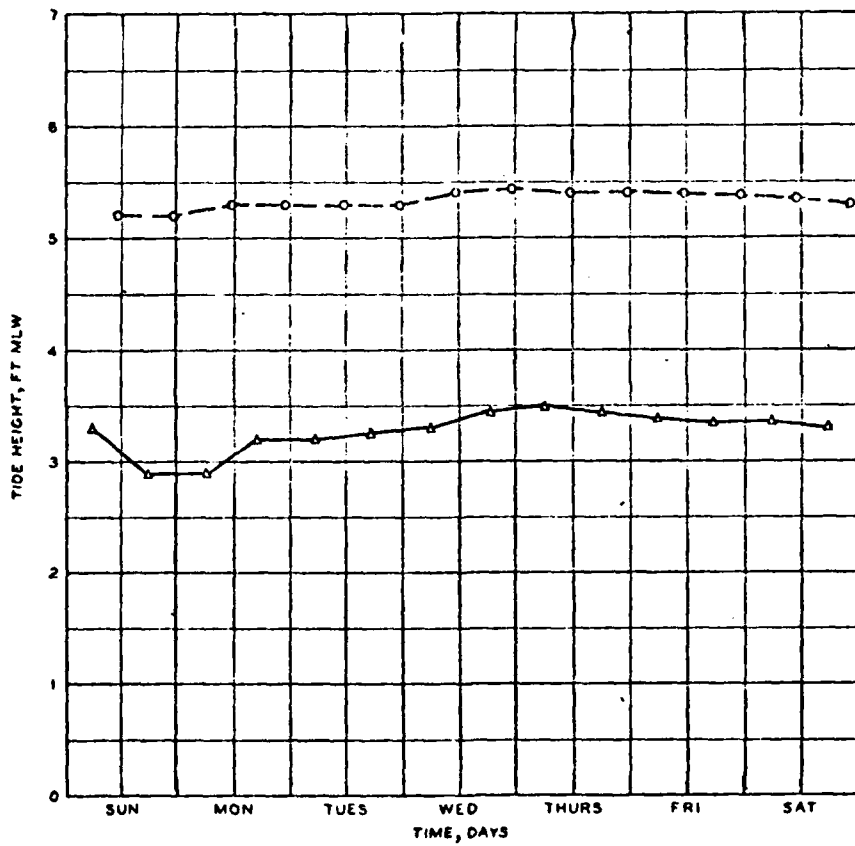
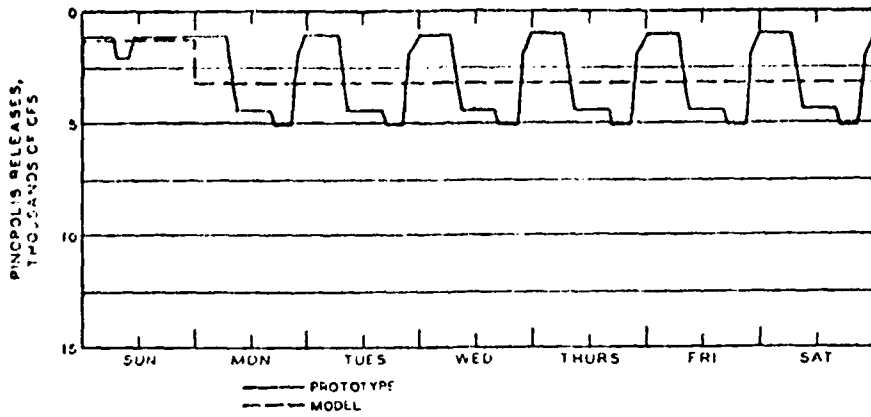

TEST CONDITIONS

OCEAN TIDE RANGE 5.4 FT  
 OCEAN SALINITY (TOTAL SALT) 30,000 PPM  
 ASHLEY RIVER 261 CFS WANDO RIVER 82 CFS  
 BUSHY PARK COMBINED WITHDRAWALS 1150 CFS  
 COOPER RIVER FLOW 3000 CFS SCHEDULE B

○—○ HIGH WATER  
 △—△ LOW WATER

CHARLESTON HARBOR MODEL  
 BUSHY PARK WATER SUPPLY TESTS

EFFECTS OF  
 SCHEDULE B WEEKLY HYDROGRAPH  
 ON MAXIMUM AND MINIMUM  
 TIDE HEIGHTS  
 STATION CR-8

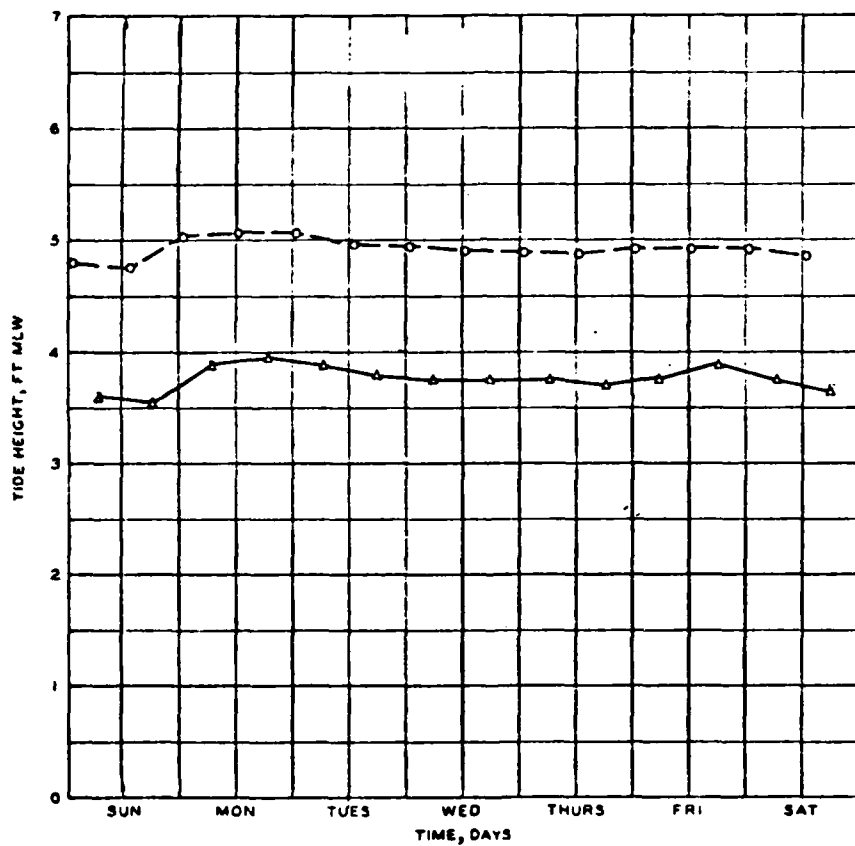
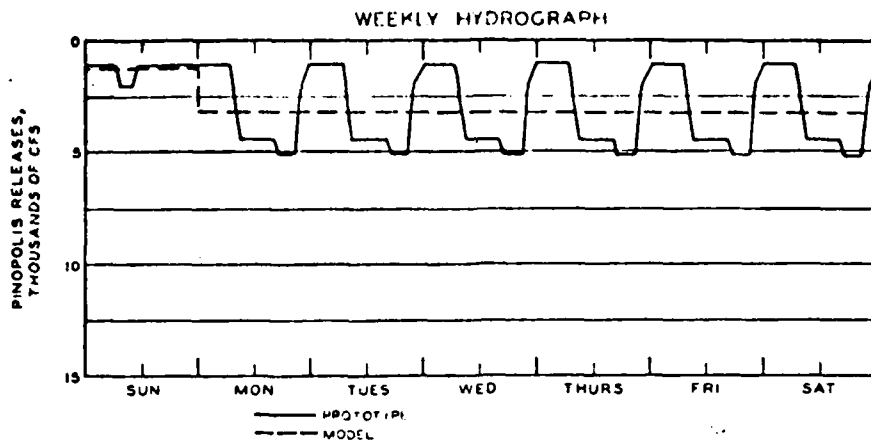

**TEST CONDITIONS**

OCEAN TIDE RANGE                    5.4 FT  
 OCEAN SALINITY (TOTAL SALT)    30,000 PPM  
 ASHLEY RIVER 261 CFS    WANDO RIVER 82 CFS  
 BUSHY PARK COMBINED WITHDRAWALS 1130 CFS  
 COOPER RIVER FLOW 3000 CFS SCHEDULE B

○ — ○    HIGH WATER  
 △ — △    LOW WATER

**CHARLESTON HARBOR MODEL  
 BUSHY PARK WATER SUPPLY TESTS**

**EFFECTS OF  
 SCHEDULE B WEEKLY HYDROGRAPH  
 ON MAXIMUM AND MINIMUM  
 TIDE HEIGHTS  
 STATION BR-1**

WEEKLY HYDROGRAPH

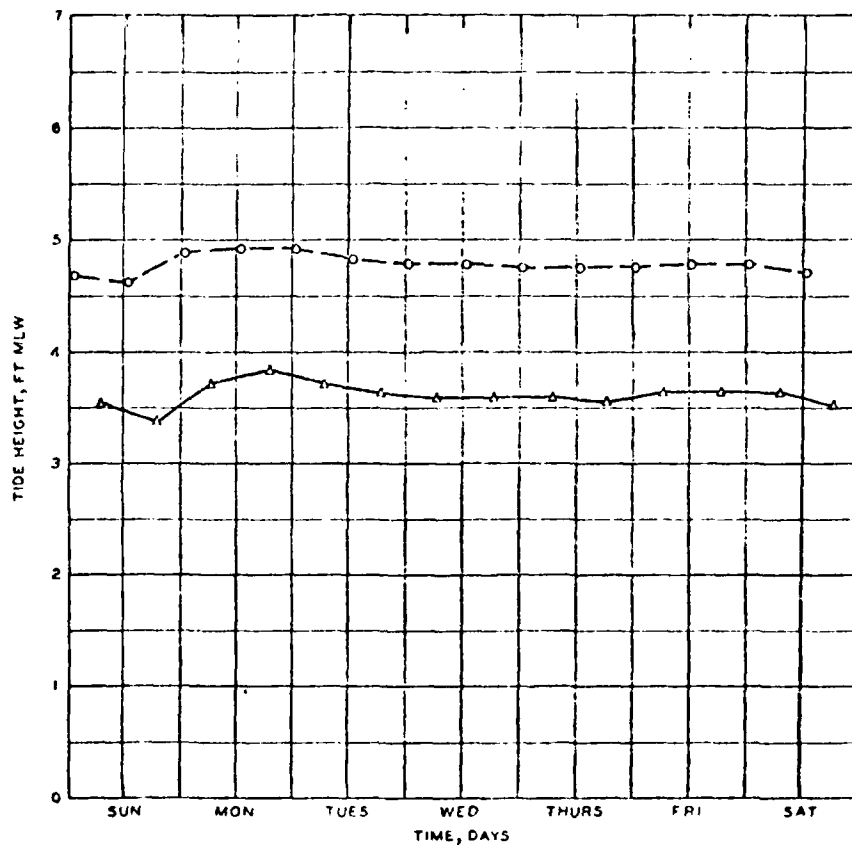
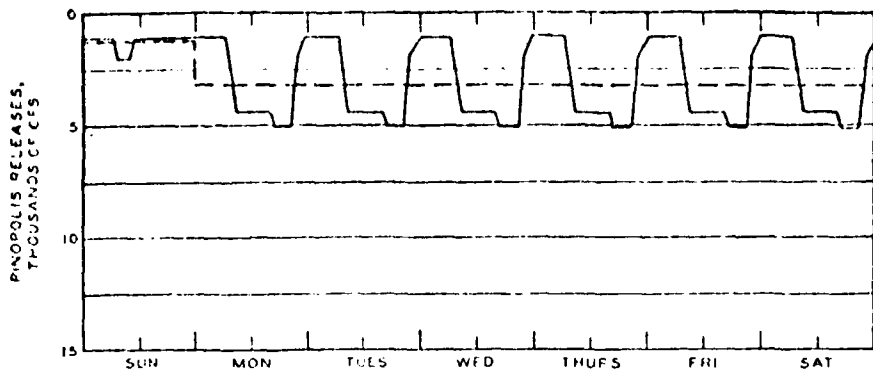

TEST CONDITIONS

OCEAN TIDE RANGE 5.4 FT  
 OCEAN SALINITY (TOTAL SALT) 30,000 PPM  
 ASHLEY RIVER 2610 CFS WANDO RIVER 82 CFS  
 BUSHY PARK COMB'D WITHDRAWALS 1120 CFS  
 COOPER RIVER FLOW 3000 CFS SCHEDULE D

○—○ HIGH WATER  
 ▲—▲ LOW WATER

CHARLESTON HARBOR MODEL  
 BUSHY PARK WATER SUPPLY TESTS  
 EFFECTS OF  
 SCHEDULE B WEEKLY HYDROGRAPH  
 ON MAXIMUM AND MINIMUM  
 TIDE HEIGHTS  
 STATION BR-2

WEEKLY HYDROGRAPH

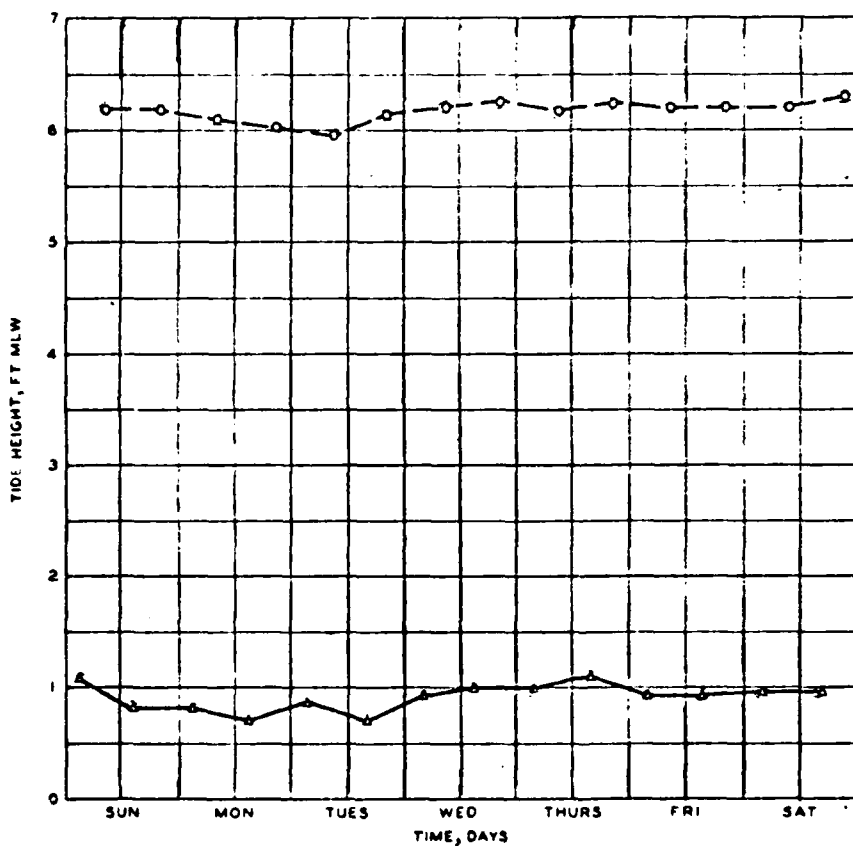
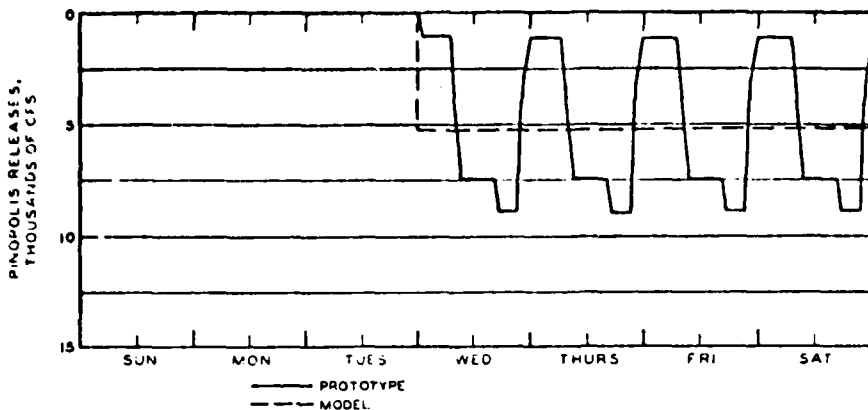

TEST CONDITIONS

OCEAN TIDE RANGE 5.4 FT  
 OCEAN SALINITY (TOTAL SALT) 30,000 PPM  
 ASHLEY RIVER 261 CFS WANDO RIVER 82 CFS  
 BUSHY PARK COMBINED WITH DHAANA 1.50 CFS  
 COOPER RIVER FLOW 3006 CFS SCHEDULE C

○—○ HIGH WATER  
 △—△ LOW WATER

CHARLESTON HARBOR MODEL  
 BUSHY PARK WATER SUPPLY TESTS

EFFECTS OF  
 SCHEDULE C WEEKLY HYDROGRAPH  
 ON MAXIMUM AND MINIMUM  
 TIDE HEIGHTS  
 STATION CR-5

WEEKLY HYDROGRAPH

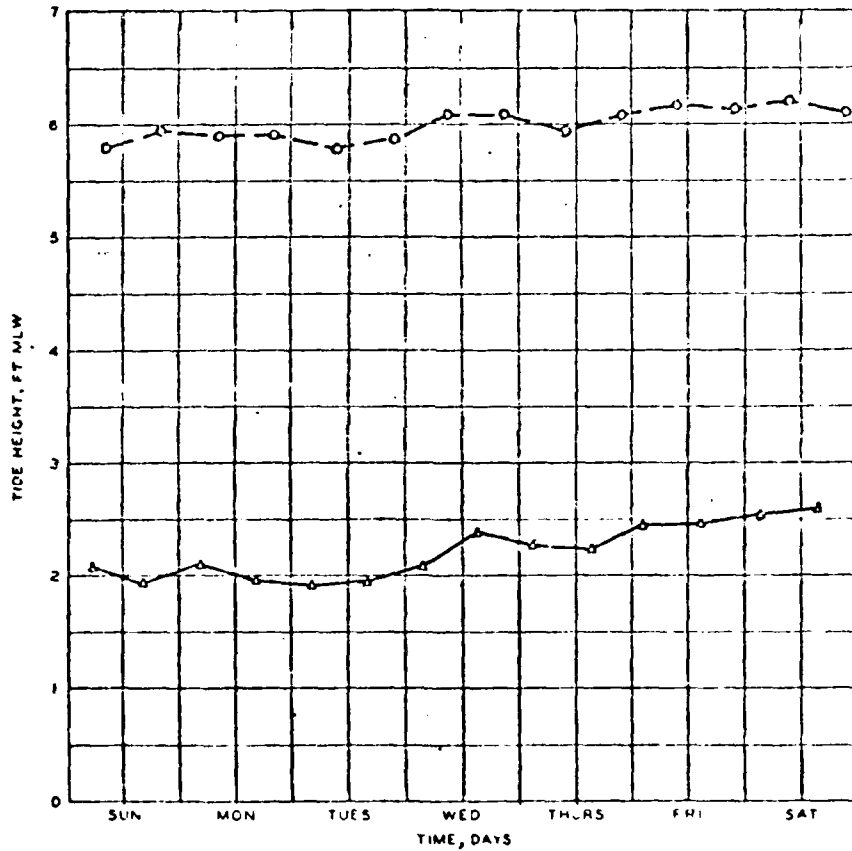
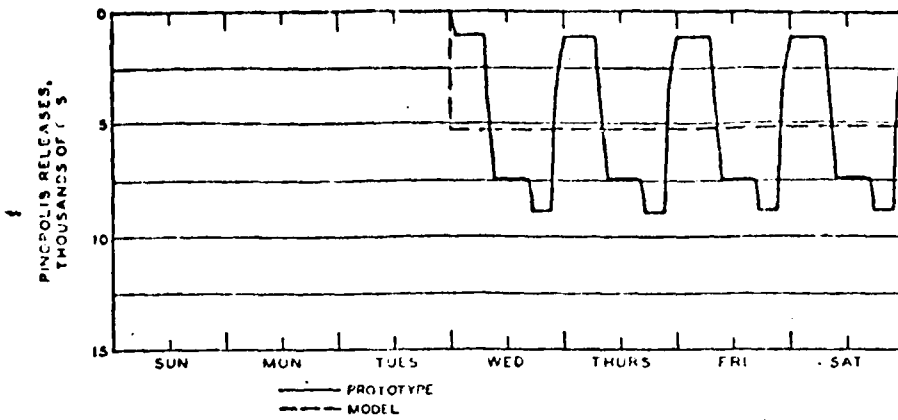

TEST CONDITIONS

OCEAN TIDE RANGE 5.4 FT  
 OCEAN SALINITY (TOTAL SALT) 30,000 PPM  
 ASHLEY RIVER 261 CFS WANDO RIVER 82 CFS  
 BUSHY PARK COMBINED WITHDRAWALS 1150 CFS  
 COOPER RIVER - LOW 3000 CFS SCHEDULE C

○ — ○ HIGH WATER  
 ▲ — ▲ LOW WATER

CHARLESTON HARBOR MODEL  
 BUSHY PARK WATER SUPPLY TESTS

EFFECTS OF  
 SCHEDULE C WEEKLY HYDROGRAPH  
 ON MAXIMUM AND MINIMUM  
 TIDE HEIGHTS  
 STATION CR-6

WEEKLY HYDROGRAPH

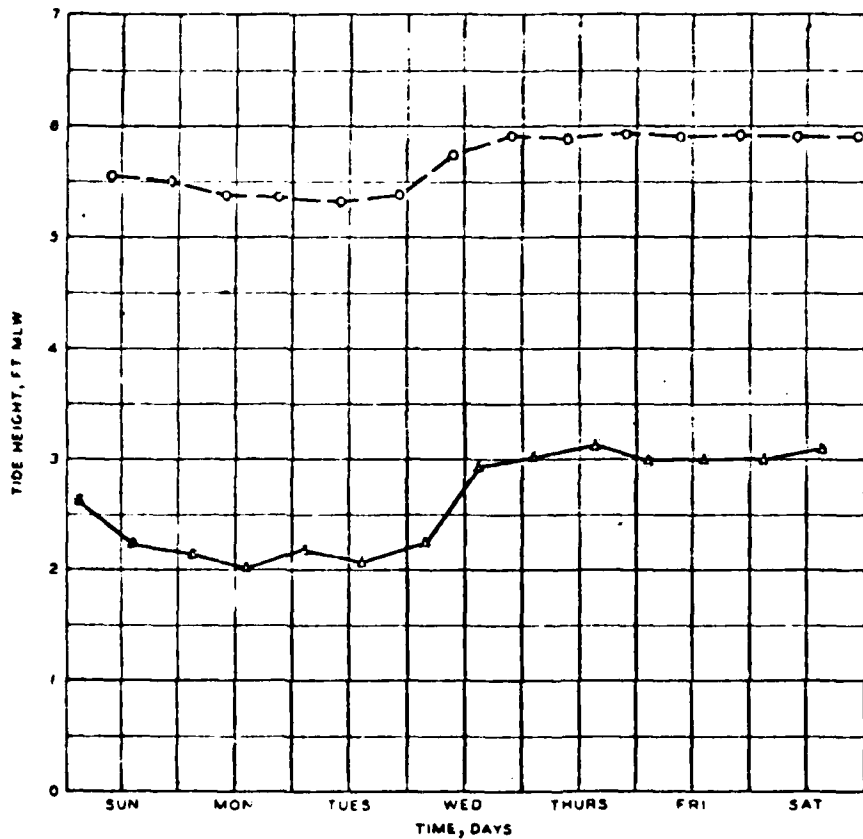
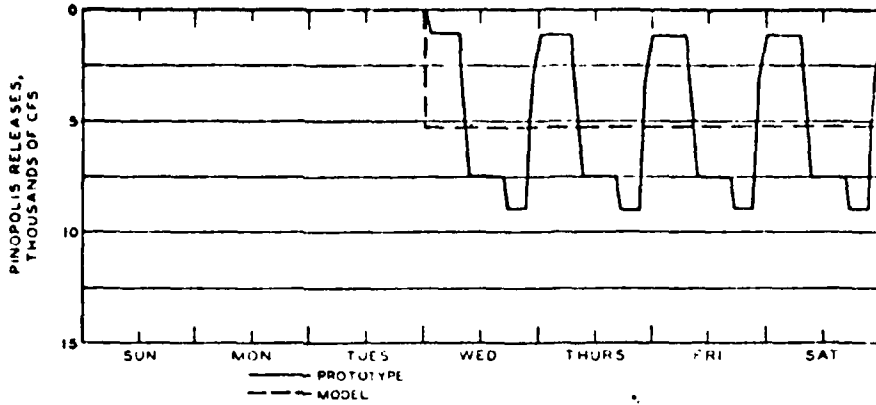

TEST CONDITIONS

OCEAN TIDE RANGE 5.4 FT  
 OCEAN SALINITY (TOTAL SALT) 30,000 PPM  
 ASHLEY RIVER 26 CFS WANDO RIVER 02 CFS  
 BUSHY PARK COMBINED WITHDRAWAL 1150 CFS  
 COOPER RIVER FLOW 3000 CFS SCHEDULE C

○ HIGH WATER  
 ▲ LOW WATER

CHARLESTON HARBOR MODEL  
 BUSHY PARK WATER SUPPLY TESTS

EFFECTS OF  
 SCHEDULE C WEEKLY HYDROGRAPH  
 ON MAXIMUM AND MINIMUM  
 TIDE HEIGHTS  
 STATION CR-7

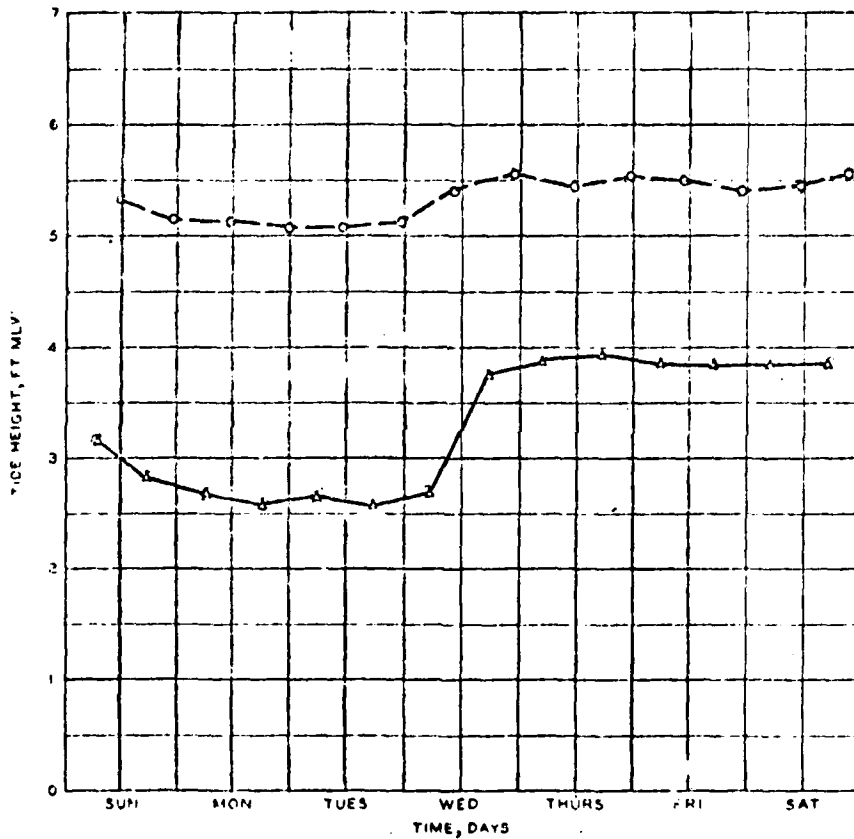
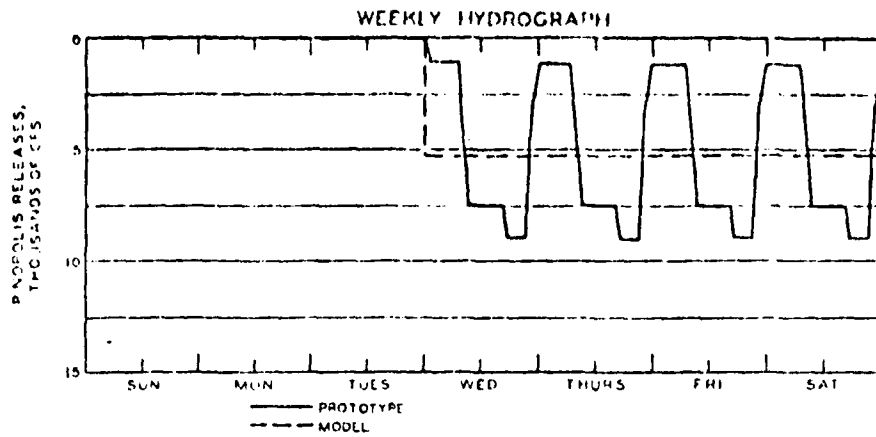

**TEST CONDITIONS**

OCEAN TIDE RANGE 5.4 FT  
 OCEAN SALINITY (TOTAL SALT) 30,000 PPM  
 ASHLEY RIVER 261 CFS WAND RIVER 82 CFS  
 BUSHY PARK COMBINED WITHDRAWALS 1150 CFS  
 COOPER RIVER FLOW 3000 CFS SCHEDULE C

○—○ HIGH WATER  
 △—△ LOW WATER

**CHARLESTON HARBOR MODEL  
 BUSHY PARK WATER SUPPLY TESTS**

**EFFECTS OF  
 SCHEDULE C WEEKLY HYDROGRAPH  
 ON MAXIMUM AND MINIMUM  
 TIDE HEIGHTS  
 STATION CR-8**

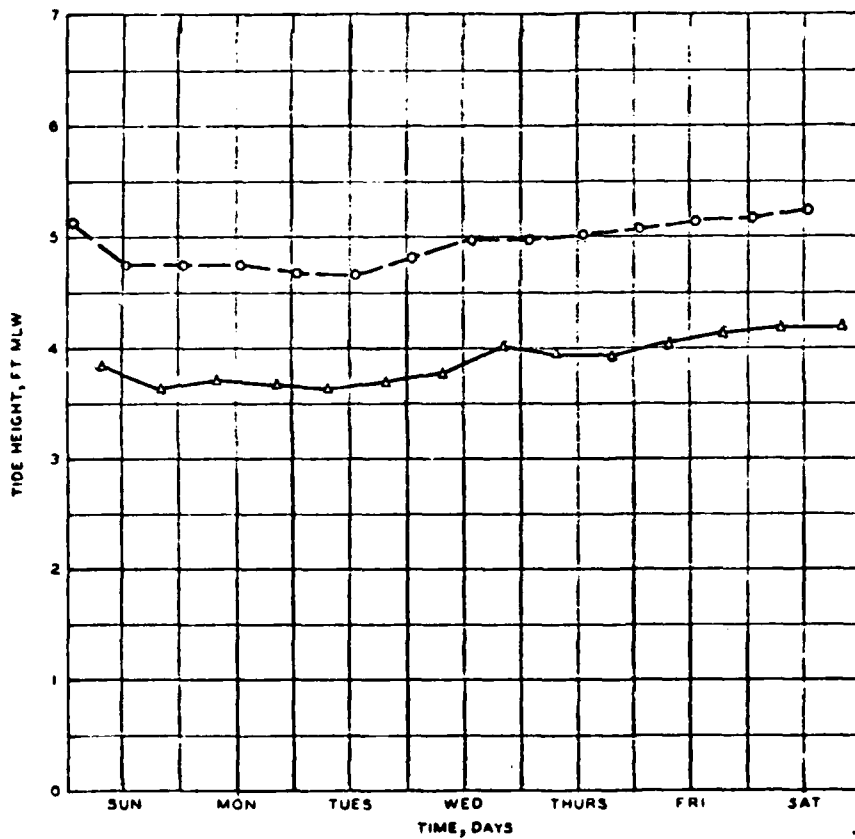
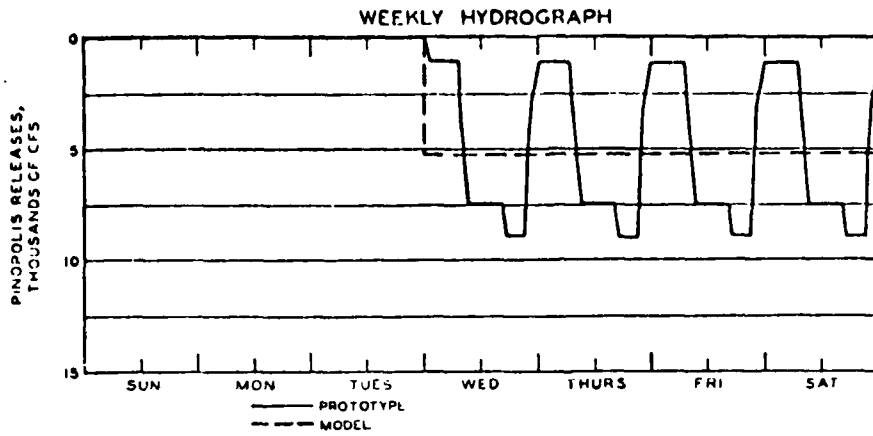

**TEST CONDITIONS**

OCEAN TIDE RANGE            5.4 FT  
 OCEAN SALINITY (TOTAL SALT)    30,000 PPM  
 ASHLEY RIVER 281 CFS    WANDO RIVER 82 CFS  
 BUSHY PARK COMBINED WITHDRAWALS 1150 CFS  
 COOPER RIVER FLOW 300 CFS, SCHEDULE C

○ — ○    HIGH WATER  
 ▲ — ▲    LOW WATER

**CHARLESTON HARBOR MODEL  
 BUSHY PARK WATER SUPPLY TESTS**

**EFFECTS OF  
 SCHEDULE C WEEKLY HYDROGRAPH  
 ON MAXIMUM AND MINIMUM  
 TIDE HEIGHTS  
 STATION BR-1**

WEEKLY HYDROGRAPH

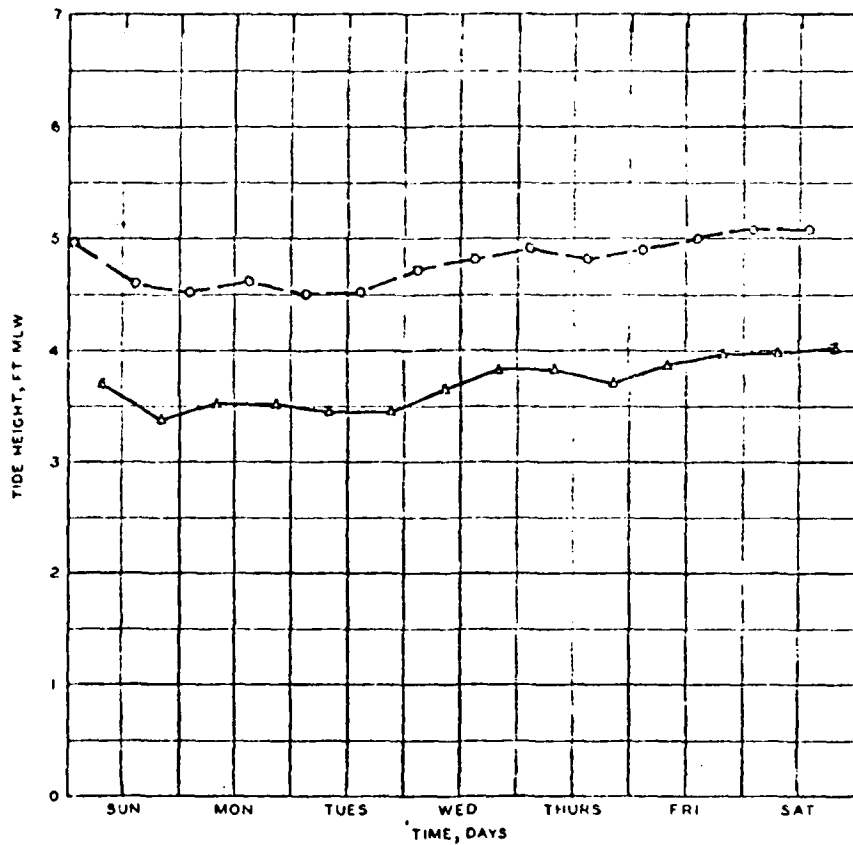
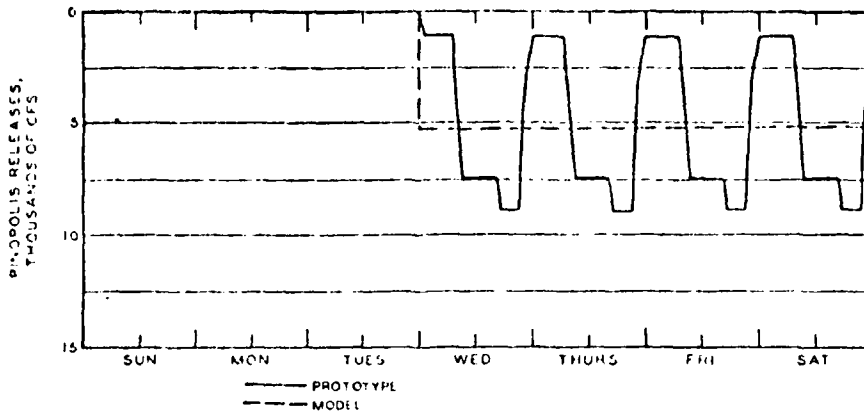

TEST CONDITIONS

OCEAN TIDE RANGE 5.4 FT  
 OCEAN SALINITY (TOTAL SALT) 30,000 PPM  
 ASHLEY RIVER 261 CFS WANDO RIVER 82 CFS  
 BUSHY PARK COMBINED WITHDRAWALS 1150 CFS  
 COOPER RIVER FLOW 3000 CFS SCHEDULE C

○—○ HIGH WATER  
 △—△ LOW WATER

CHARLESTON HARBOR MODEL  
 BUSHY PARK WATER SUPPLY TESTS

EFFECTS OF  
 SCHEDULE C WEEKLY HYDROGRAPH  
 ON MAXIMUM AND MINIMUM  
 TIDE HEIGHTS  
 STATION BR-2

WEEKLY HYDROGRAPH

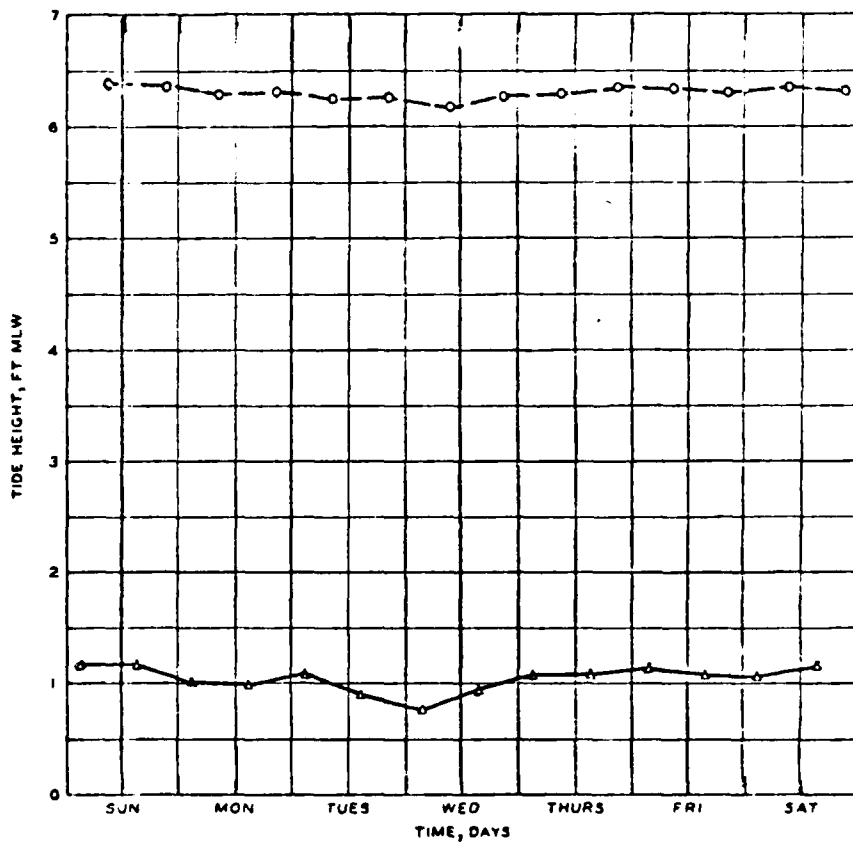
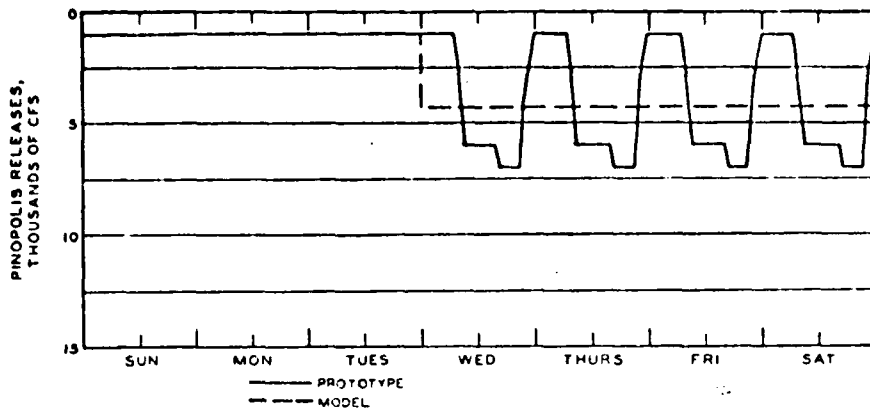

TEST CONDITIONS

OCEAN TIDE RANGE 5.4 FT  
 OCEAN SALINITY (TOT AL SALT) 30,000 PPM  
 ASHLEY RIVER 261 CFS WANDO RIVER 82 CFS  
 BUSHY PARK COMBINED WITHDRAWALS 1150 CFS  
 COOPER RIVER FLOW 3000 CFS SCHEDULE D

○—○ HIGH WATER  
 △—△ LOW WATER

CHARLESTON HARBOR MODEL  
 BUSHY PARK WATER SUPPLY TESTS  
 EFFECTS OF  
 SCHEDULE D WEEKLY HYDROGRAPH  
 ON MAXIMUM AND MINIMUM  
 TIDE HEIGHTS  
 STATION CR-5

WEEKLY HYDROGRAPH

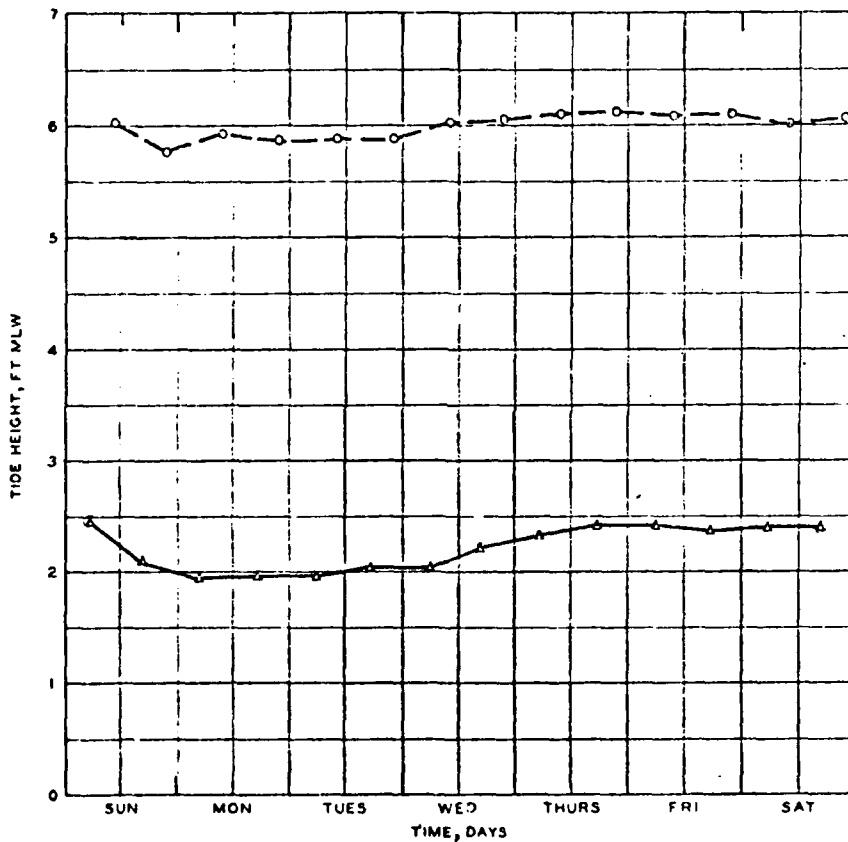
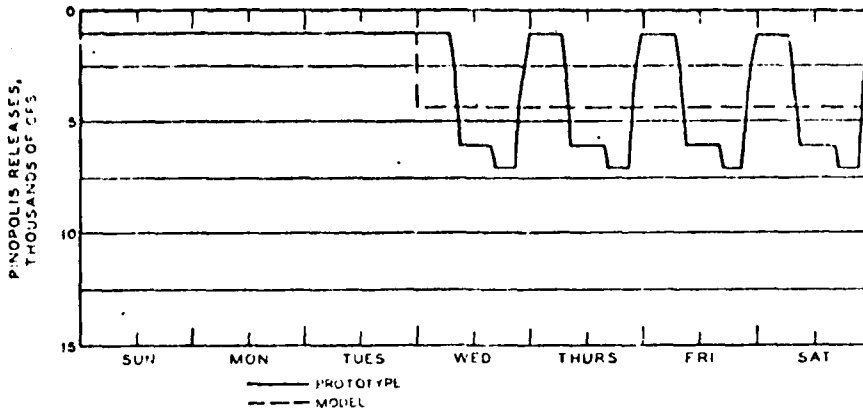

TEST CONDITIONS

OCEAN TIDE RANGE 5.4 FT  
 OCEAN SALINITY (TOTAL SALT) 30,000 PPM  
 ASHLEY RIVER 261 CFS WANDO RIVER 82 CFS  
 BUSHY PARK COMBINED WITHDRAWALS 1150 CFS  
 COOPER RIVER FLOW 3000 CFS SCHEDULE D

○—○ HIGH WATER  
 ▲—▲ LOW WATER

CHARLESTON HARBOR MODEL  
 BUSHY PARK WATER SUPPLY TESTS

EFFECTS OF  
 SCHEDULE D WEEKLY HYDROGRAPH  
 ON MAXIMUM AND MINIMUM  
 TIDE HEIGHTS  
 STATION CR-6

WEEKLY HYDROGRAPH

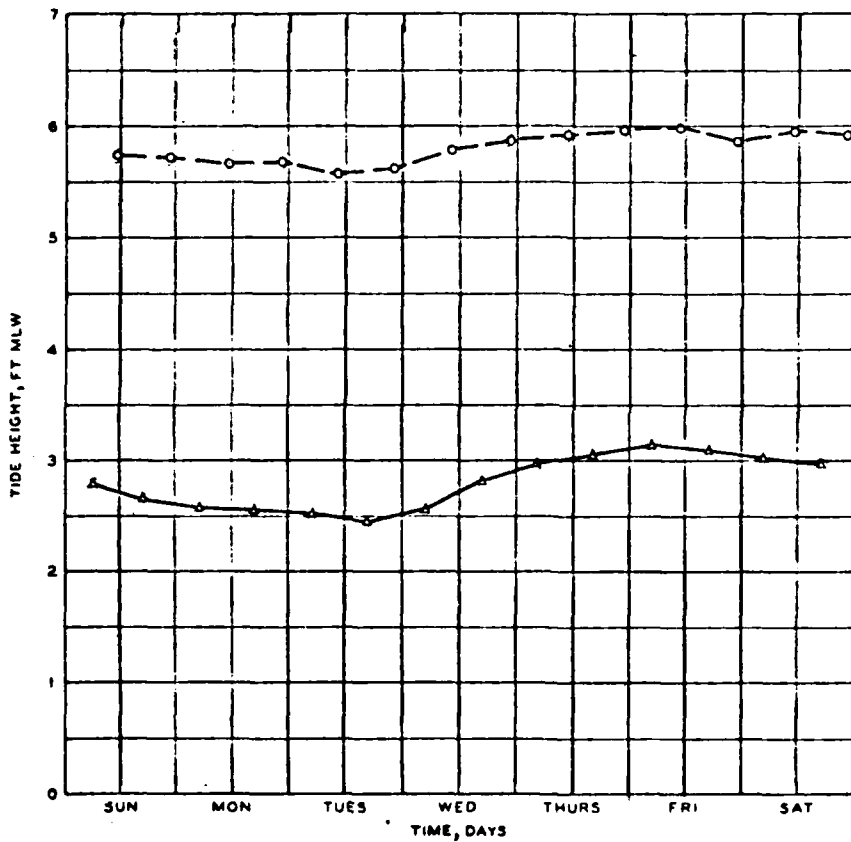
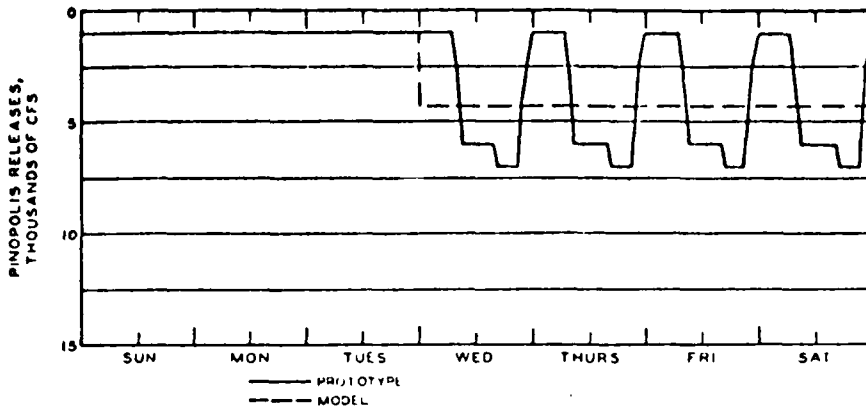

TEST CONDITIONS

OCEAN TIDE RANGE 5.4 FT  
 OCEAN SALINITY (TOTAL SALT) 30000 PPM  
 ASHLEY RIVER 261 CFS WANDO RIVER 82 CFS  
 BUSHY PARK COMBINED WITHDRAWALS 1150 CFS  
 COOPER RIVER FLOW 3000 CFS SCHEDULE D

○ — ○ HIGH WATER  
 — ▲ — LOW WATER

CHARLESTON HARBOR MODEL  
 BUSHY PARK WATER SUPPLY TESTS

EFFECTS OF  
 SCHEDULE D WEEKLY HYDROGRAPH  
 ON MAXIMUM AND MINIMUM  
 TIDE HEIGHTS  
 STATION CR-7

WEEKLY HYDROGRAPH

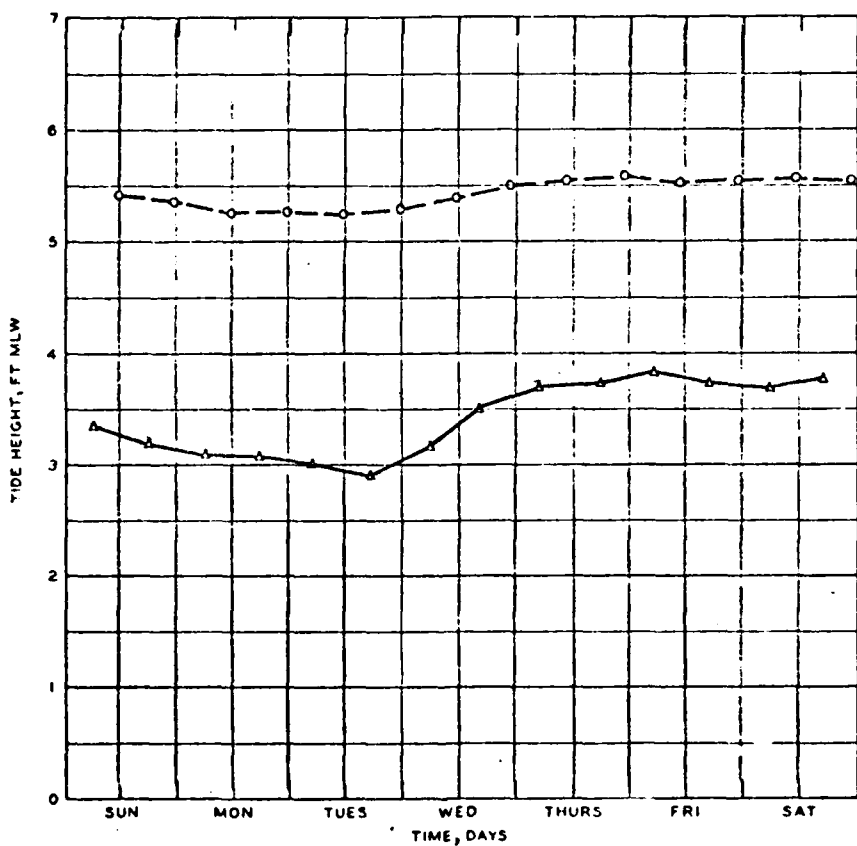
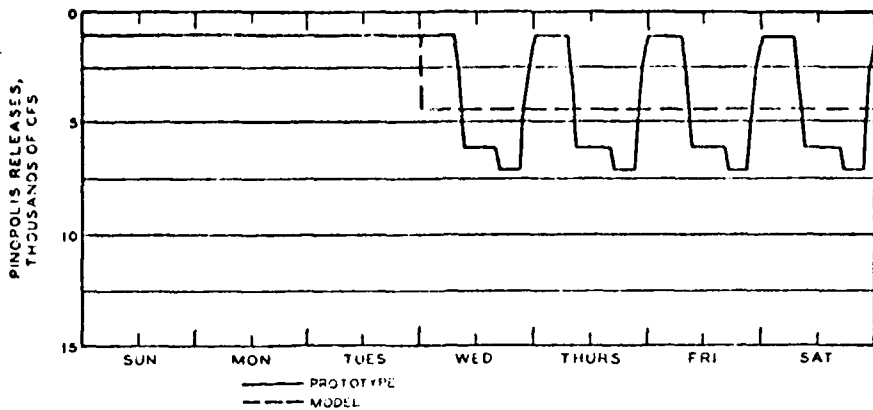

TEST CONDITIONS

OCEAN TIDE RANGE 5.4 FT  
 OCEAN SALINITY (TOTAL SALT) 30,000 PPM  
 ASHLEY RIVER 261 CFS WANDO RIVER 82 CFS  
 BUSHY PARK COMBINED WITHDRAWALS 1150 CFS  
 COOPER RIVER FLOW 3000 CFS SCHEDULE Q

○ — ○ HIGH WATER  
 ▲ — ▲ LOW WATER

CHARLESTON HARBOR MODEL  
 BUSHY PARK WATER SUPPLY TESTS

EFFECTS OF  
 SCHEDULE D WEEKLY HYDROGRAPH  
 ON MAXIMUM AND MINIMUM  
 TIDE HEIGHTS  
 STATION CR-8

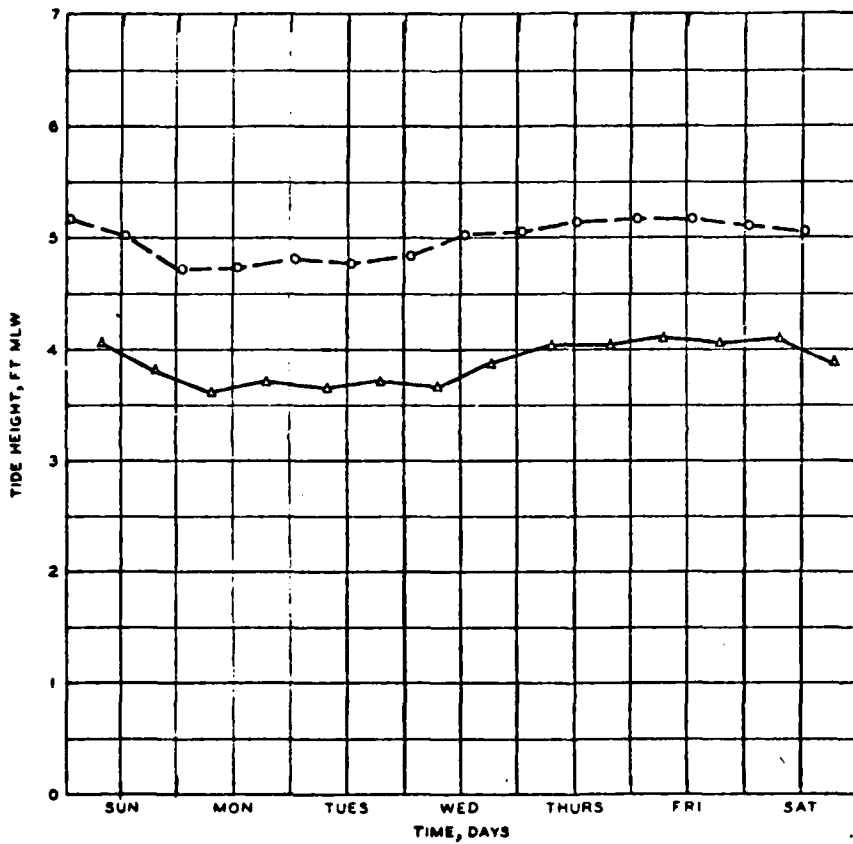
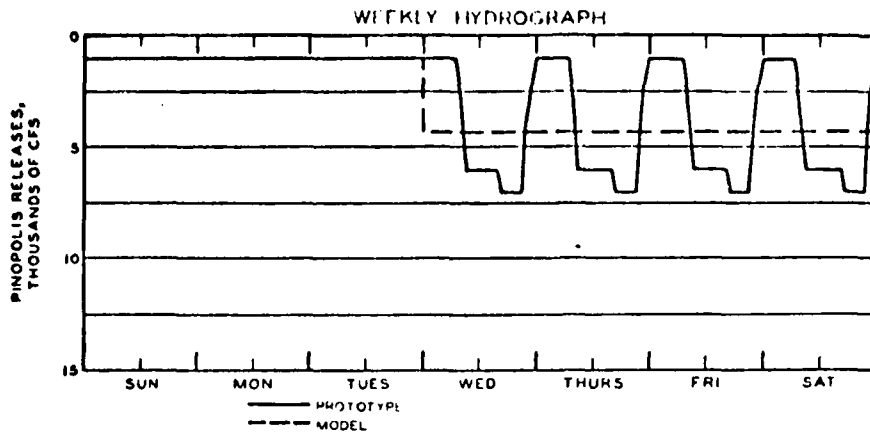

**TEST CONDITIONS**

OCEAN TIDE RANGE                    5.4 FT  
 OCEAN SALINITY (TOTAL SALT)    30,000 PPM  
 ASHLEY RIVER 261 CFS    WANDO RIVER 82 CFS  
 BUSHY PARK COMBINED WITHDRAWALS 1150 CFS  
 COOPER RIVER FLOW 3000 CFS SCHEDULE D

○ — ○    HIGH WATER  
 ▲ — ▲    LOW WATER

CHARLESTON HARBOR MODEL  
 BUSHY PARK WATER SUPPLY TESTS  
 EFFECTS OF  
 SCHEDULE D WEEKLY HYDROGRAPH  
 ON MAXIMUM AND MINIMUM  
 TIDE HEIGHTS  
 STATION BR-1

WEEKLY HYDROGRAPH

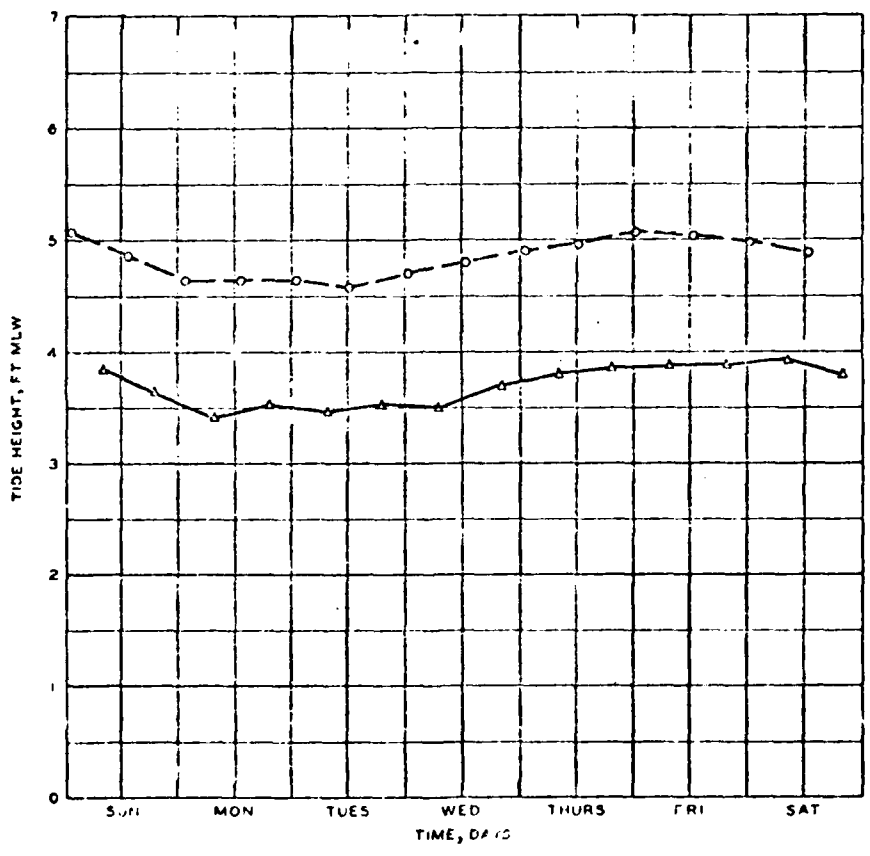
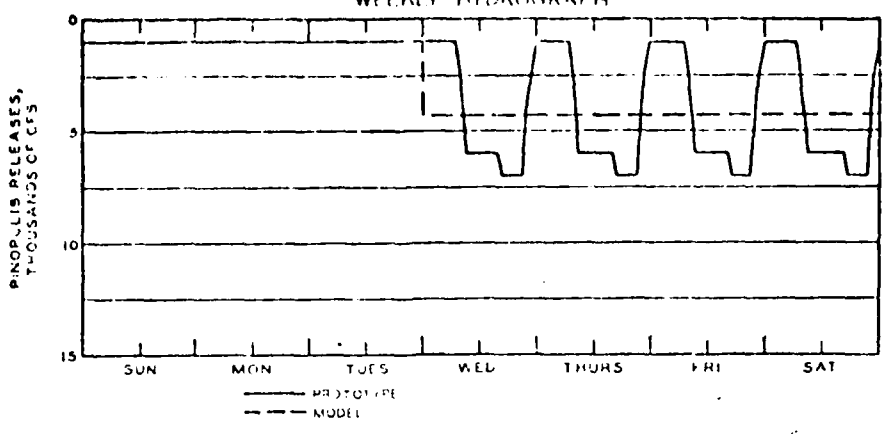

TEST CONDITIONS

OCEAN TIDE RANGE 5.4 FT  
 OCEAN SALINITY (TOTAL SALT) 30,000 PPM  
 ASHLEY RIVER 26 CFS WANDO RIVER 83 CFS  
 BUSHY PARK COMBINED WITHDRAWALS 1150 CFS  
 COOPER RIVER FLOW 3000 CFS SCHEDULE D

○ — ○ HIGH WATER  
 ▲ — ▲ LOW WATER

CHARLESTON HARBOR MODEL  
 BUSHY PARK WATER SUPPLY TESTS

EFFECTS OF  
 SCHEDULE D WEEKLY HYDROGRAPH  
 ON MAXIMUM AND MINIMUM  
 TIDE HEIGHTS  
 STATION BR-2

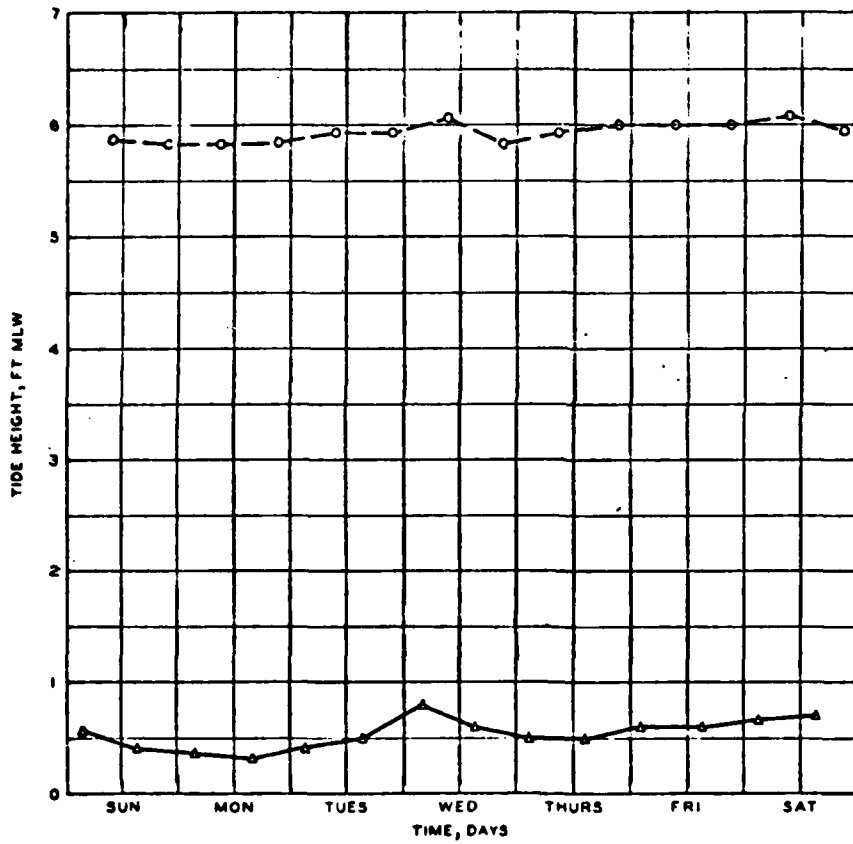
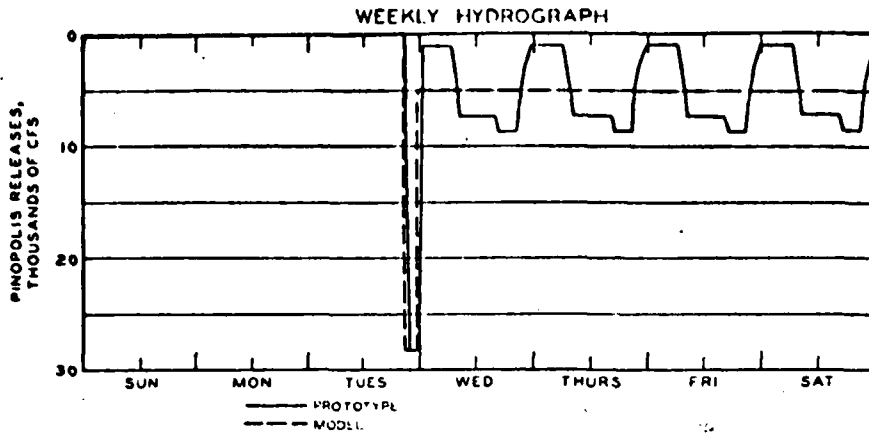

**TEST CONDITIONS**

OCEAN TIDE RANGE 5.4 FT  
 OCEAN SALINITY (TOTAL SALT) 30,000 PPM  
 ASHLEY RIVER 261 CFS WANDO RIVER 82 CFS  
 BUSHY PARK COMBINED WITHDRAWALS 1150 CFS  
 COOPER RIVER FLOW 3500 CFS SCHEDULE E

○ — ○ HIGH WATER  
 ▲ — ▲ LOW WATER

CHARLESTON HARBOR MODEL  
 BUSHY PARK WATER SUPPLY TESTS

**EFFECTS OF  
 SCHEDULE E WEEKLY HYDROGRAPH  
 ON MAXIMUM AND MINIMUM  
 TIDE HEIGHTS  
 STATION CR-5**

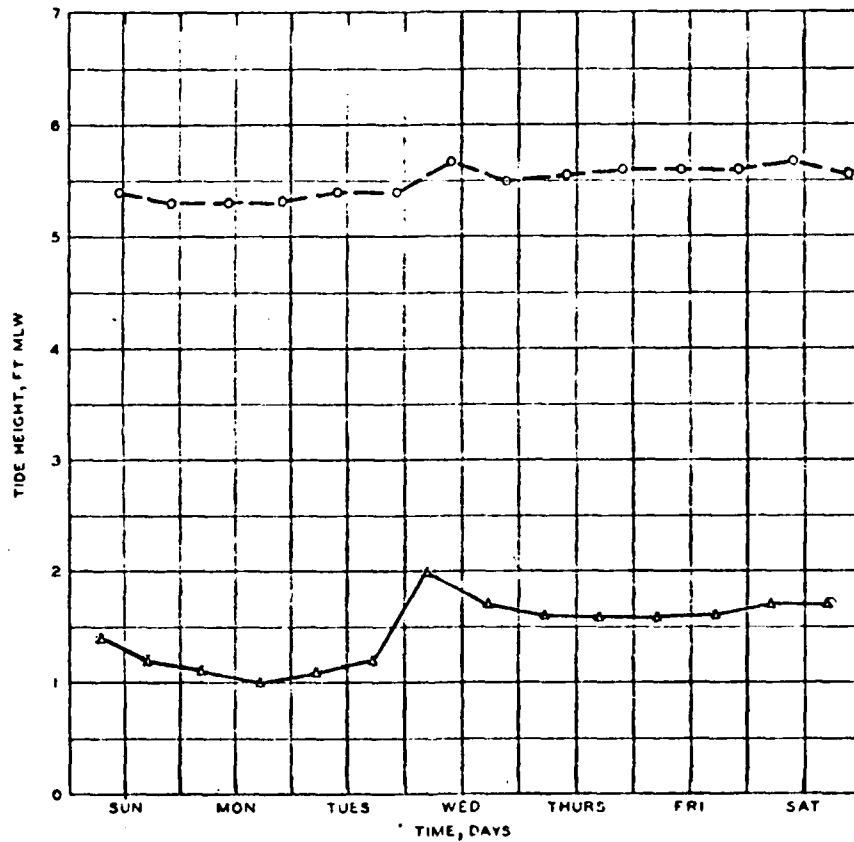
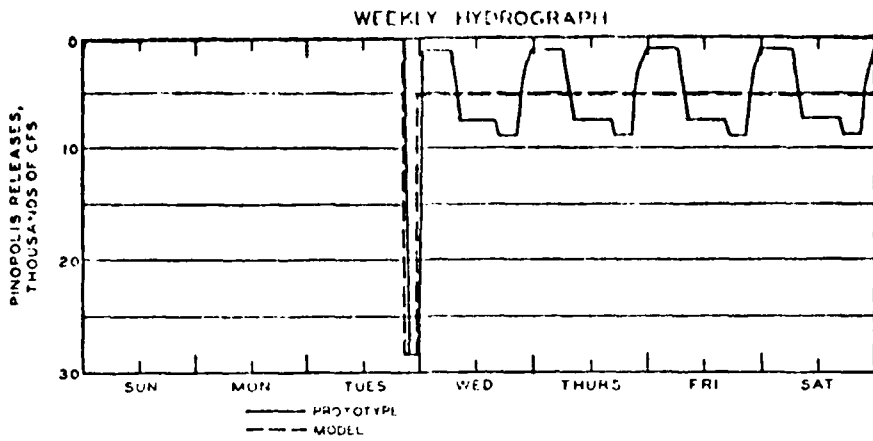

**TEST CONDITIONS**

OCEAN TIDE RANGE 5.4 FT  
 OCEAN SALINITY (TOTAL SALT) 30,000 PPM  
 ASHLEY RIVER 261 CFS WANDO RIVER 82 CFS  
 BUSHY PARK COMBINED WITHDRAWALS 1150 CFS  
 COOPER RIVER FLOW 3500 CFS SCHEDULE E

○ — ○ HIGH WATER  
 ▲ — ▲ LOW WATER

CHARLESTON HARBOR MODEL  
 BUSHY PARK WATER SUPPLY TESTS  
 EFFECTS OF  
 SCHEDULE E WEEKLY HYDROGRAPH  
 ON MAXIMUM AND MINIMUM  
 TIDE HEIGHTS  
 STATION CR-6

WEEKLY HYDROGRAPH

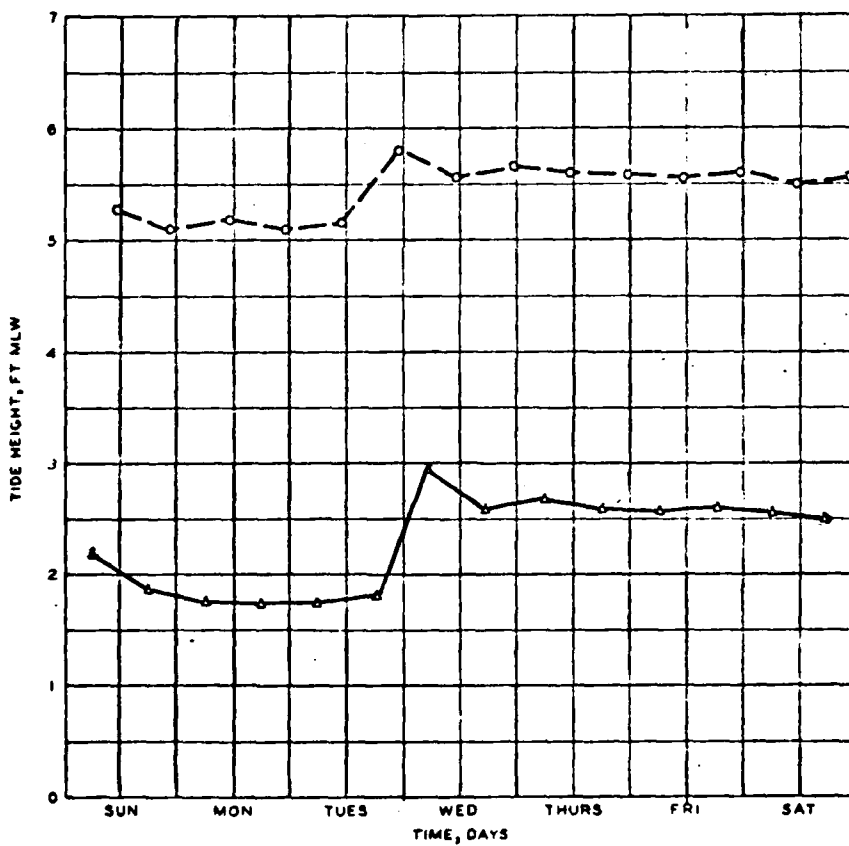
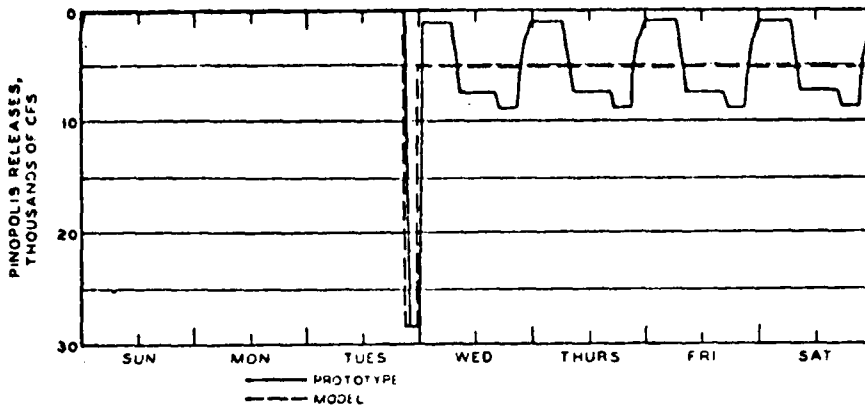

TEST CONDITIONS

OCEAN TIDE RANGE 5.4 FT  
 OCEAN SALINITY (TOTAL SALT) 30,000 PPM  
 ASHLEY RIVER 281 CFS WANDO RIVER 82 CFS  
 BUSHY PARK COMBINED WITHDRAWALS 1150 CFS  
 COOPER RIVER FLOW 3300 CFS SCHEDULE E

○ — ○ HIGH WATER  
 □ — □ LOW WATER

CHARLESTON HARBOR MODEL  
 BUSHY PARK WATER SUPPLY TESTS

EFFECTS OF  
 SCHEDULE E WEEKLY HYDROGRAPH  
 ON MAXIMUM AND MINIMUM  
 TIDE HEIGHTS  
 STATION CR-7

WEEKLY HYDROGRAPH

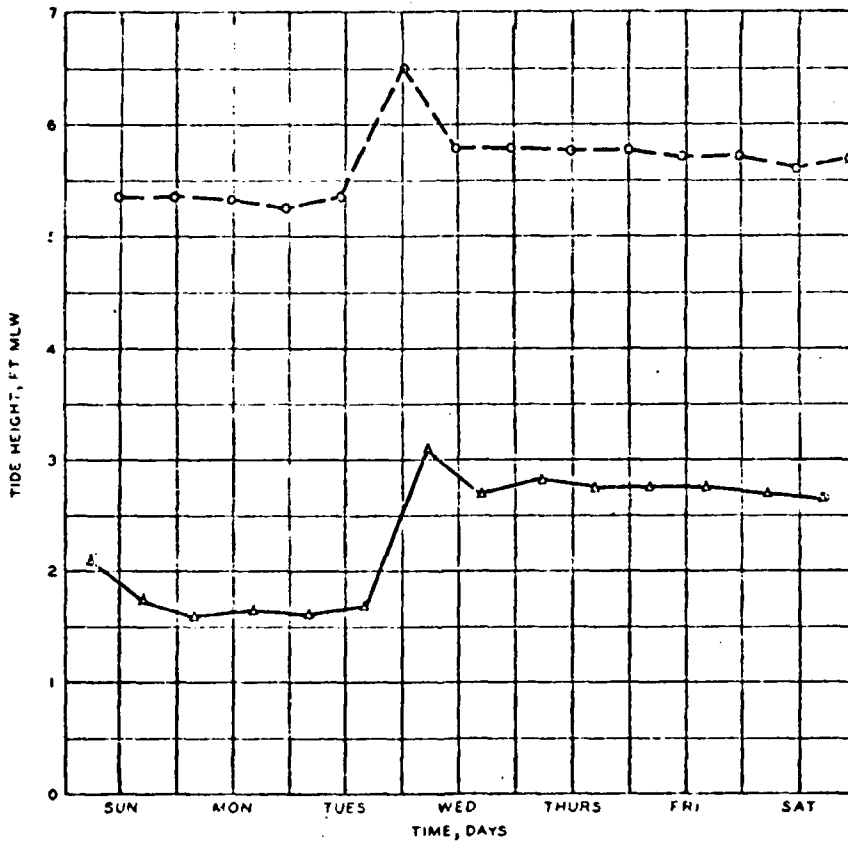
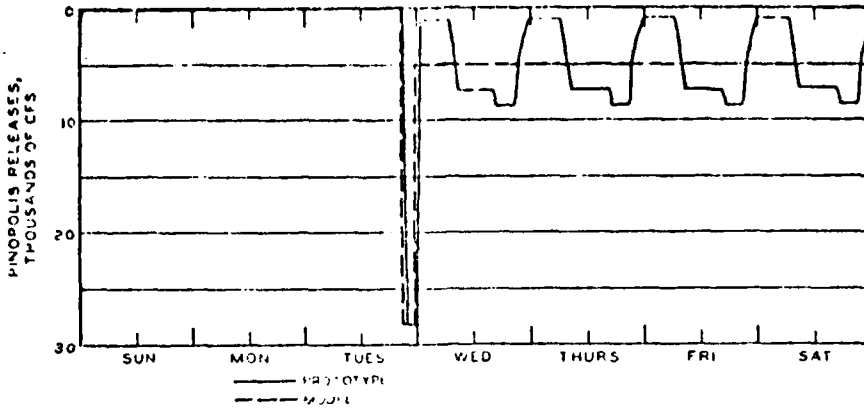

TEST CONDITIONS

OCEAN TIDE RANGE 5.4 FT  
 OCEAN SALINITY (TOTAL SALT) 30,000 PPM  
 ASHLEY RIVER 261 CFS WANDO RIVER 82 CFS  
 BUSHY PARK COMBINED WITH WAWA 5,115 CFS  
 COOPER RIVER FLOW 3500 CFS SCHEDULE E

○ — ○ HIGH WATER  
 ▲ — ▲ LOW WATER

CHARLESTON HARBOR MODEL  
 BUSHY PARK WATER SUPPLY TESTS

EFFECTS OF  
 SCHEDULE E WEEKLY HYDROGRAPH  
 ON MAXIMUM AND MINIMUM  
 TIDE HEIGHTS  
 STATION CR-8

WEEKLY HYDROGRAPH

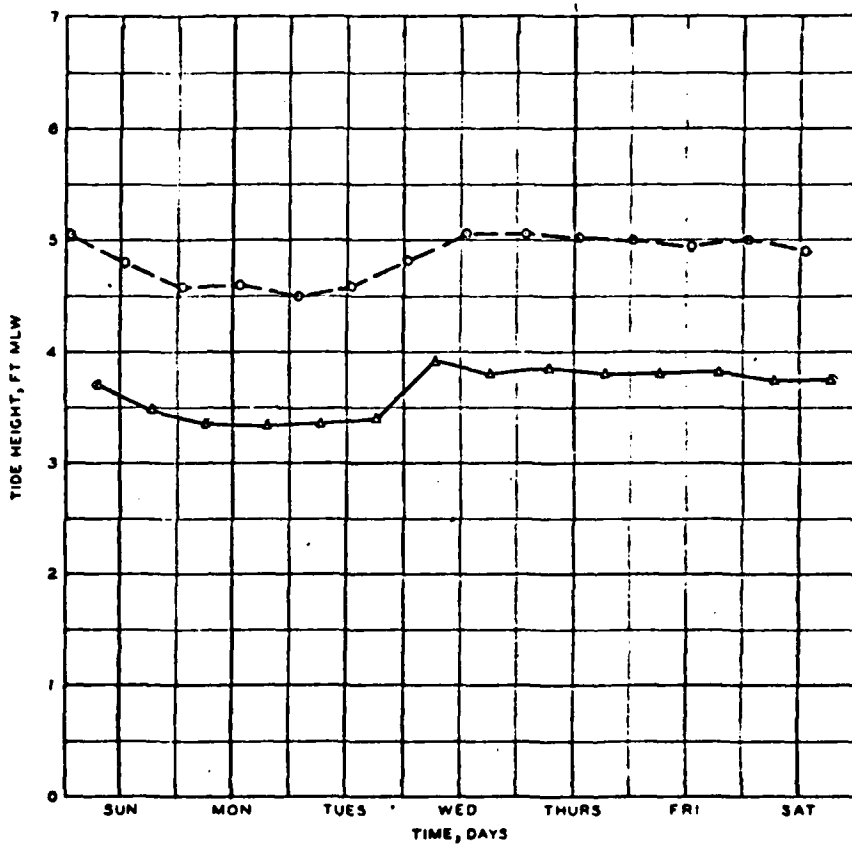
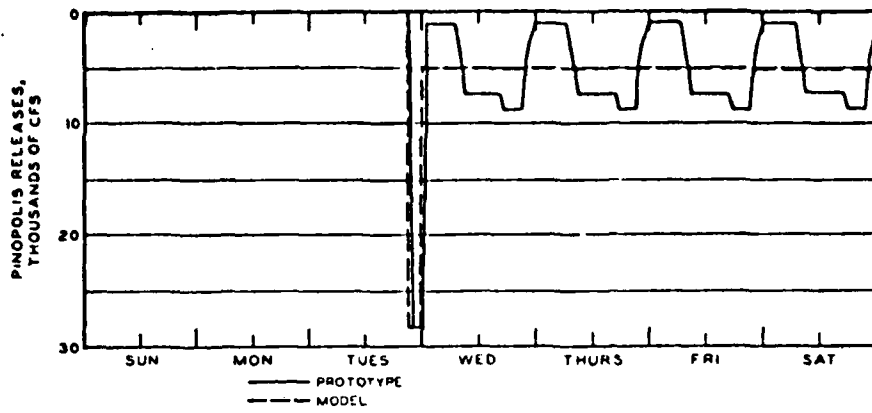

TEST CONDITIONS

OCEAN TIDE RANGE 5.4 FT  
 OCEAN SALINITY (TOTAL SALT) 30,000 PPM  
 ASHLEY RIVER 281 CFS WANDO RIVER 82 CFS  
 BUSHY PARK COMBINED WITHDRAWALS 1150 CFS  
 COOPER RIVER FLOW 3500 CFS SCHEDULE E

○ — ○ HIGH WATER  
 ▲ — ▲ LOW WATER

CHARLESTON HARBOR MODEL  
 BUSHY PARK WATER SUPPLY TESTS

EFFECTS OF  
 SCHEDULE E WEEKLY HYDROGRAPH  
 ON MAXIMUM AND MINIMUM  
 TIDE HEIGHTS  
 STATION BR-1

WEEKLY HYDROGRAPH

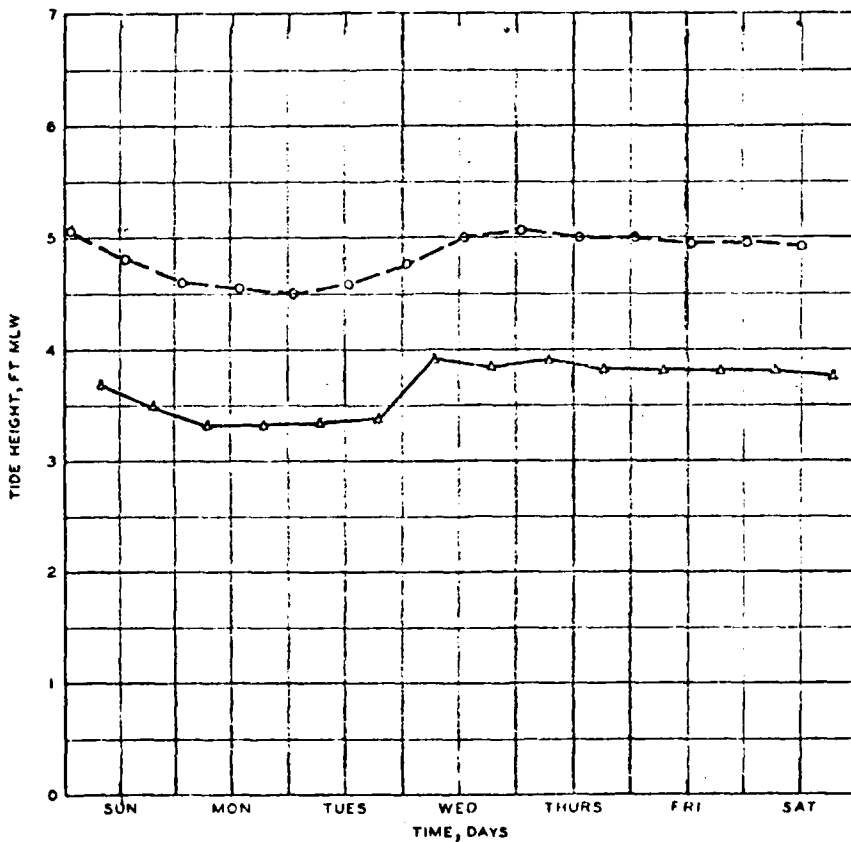
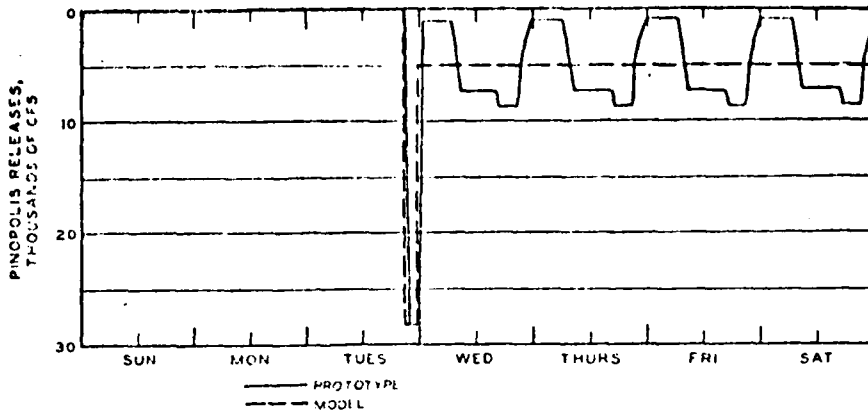

TEST CONDITIONS

OCEAN TIDE RANGE 5.4 FT  
 OCEAN SALINITY (TOTAL SALT) 30,000 PPM  
 ASHLEY RIVER 261 CFS WANDO RIVER 82 CFS  
 BUSHY PARK COMBINED WITHDRAWALS 1150 CFS  
 COOPER RIVER FLOW 3500 CFS SCHEDULE E

○—○ HIGH WATER  
 △—△ LOW WATER

CHARLESTON HARBOR MODEL  
 BUSHY PARK WATER SUPPLY TESTS

EFFECTS OF  
 SCHEDULE E WEEKLY HYDROGRAPH  
 ON MAXIMUM AND MINIMUM  
 TIDE HEIGHTS

STATION BR-2

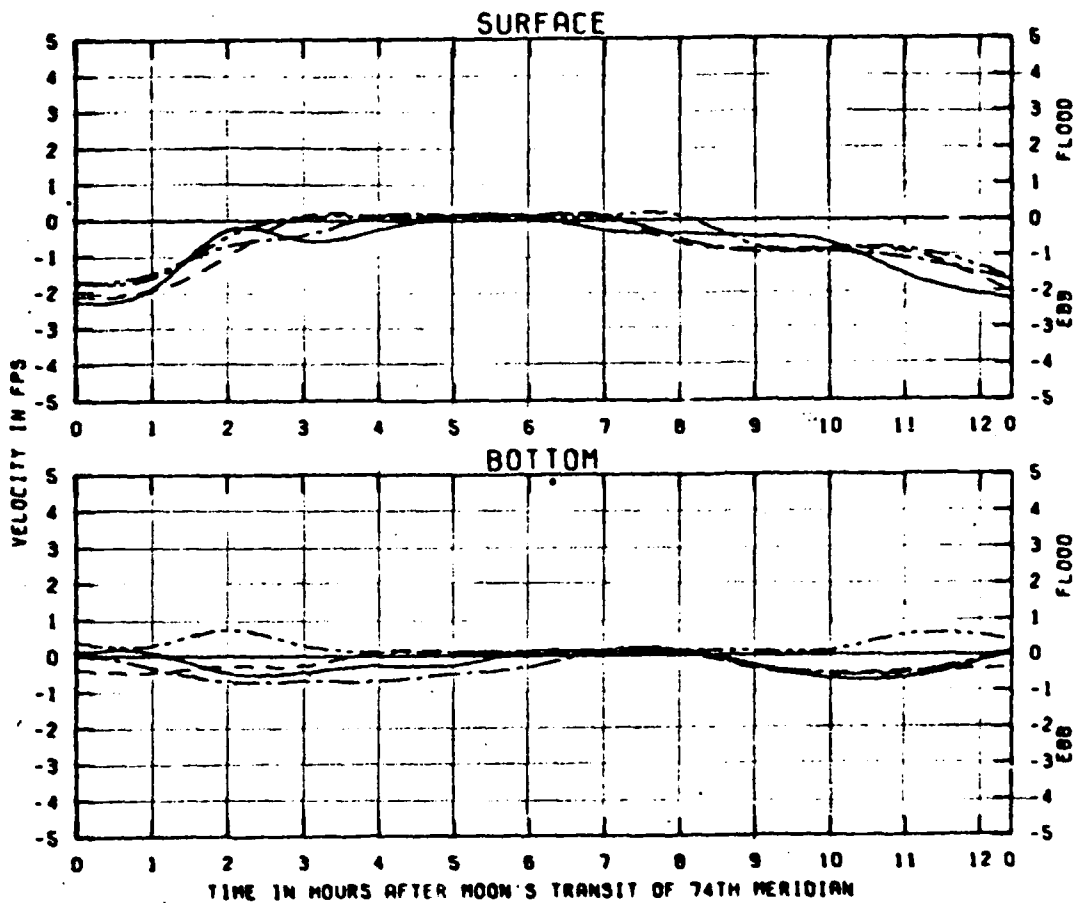

TEST CONDITIONS  
 OCEAN TIDE RANGE 5.4 FT  
 OCEAN SALINITY (TOTAL SALT) 30.0 PPT  
 BUSHY PARK COMBINED WITHDRAWALS 1150 CFS  
 RASLEY RIVER 261 CFS MANDO RIVER 82 CFS  
 COOPER RIVER - VARIOUS WEEKLY HYDROGRAPHS

LEGEND  
 Sch. A ———  
 Sch. B - - - -  
 Sch. E - · - -  
 Sch. BM - · · -

CHARLESTON HARBOR MODEL  
 BUSHY PARK WATER SUPPLY TESTS

CURRENT VELOCITIES FOR  
 WEEKLY HYDROGRAPH  
 SCHEDULES A, B, E, AND BM  
 COOPER RIVER MILE 0

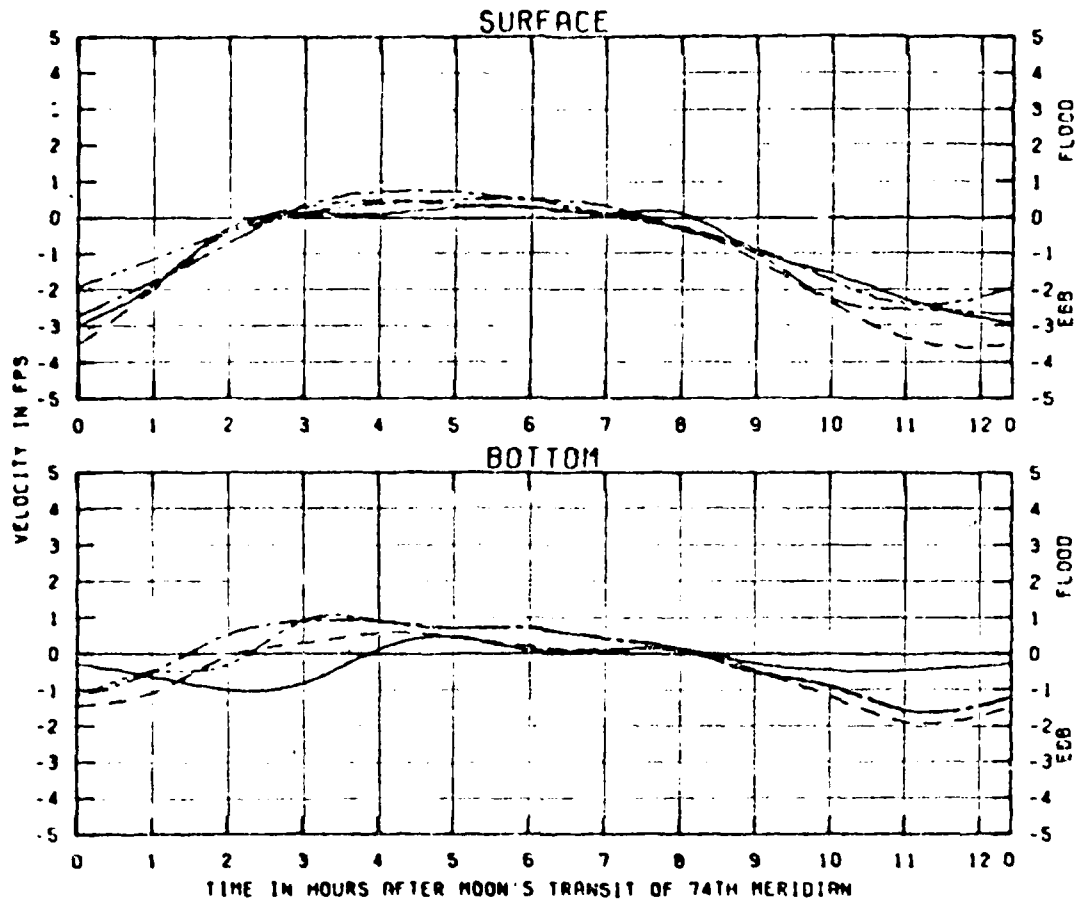

TEST CONDITIONS  
 OCEAN TIDE RANGE 5.4 FT  
 OCEAN SALINITY (TOTAL SALT) 30.0 PPT  
 BUSHY PARK COMBINED WITHDRAWALS 1150 CFS  
 ASHLEY RIVER 261 CFS WANDO RIVER 82 CFS  
 COOPER RIVER - VARIOUS WEEKLY HYDROGRAPHS

CHARLESTON HARBOR MODEL  
 BUSHY PARK WATER SUPPLY TESTS

CURRENT VELOCITIES FOR  
 WEEKLY HYDROGRAPH  
 SCHEDULES A, B, E, AND BM  
 COOPER RIVER MILE 2

LEGEND  
 Sch. A ————  
 Sch. B - - - -  
 Sch. E - · - -  
 Sch. BM - · · -

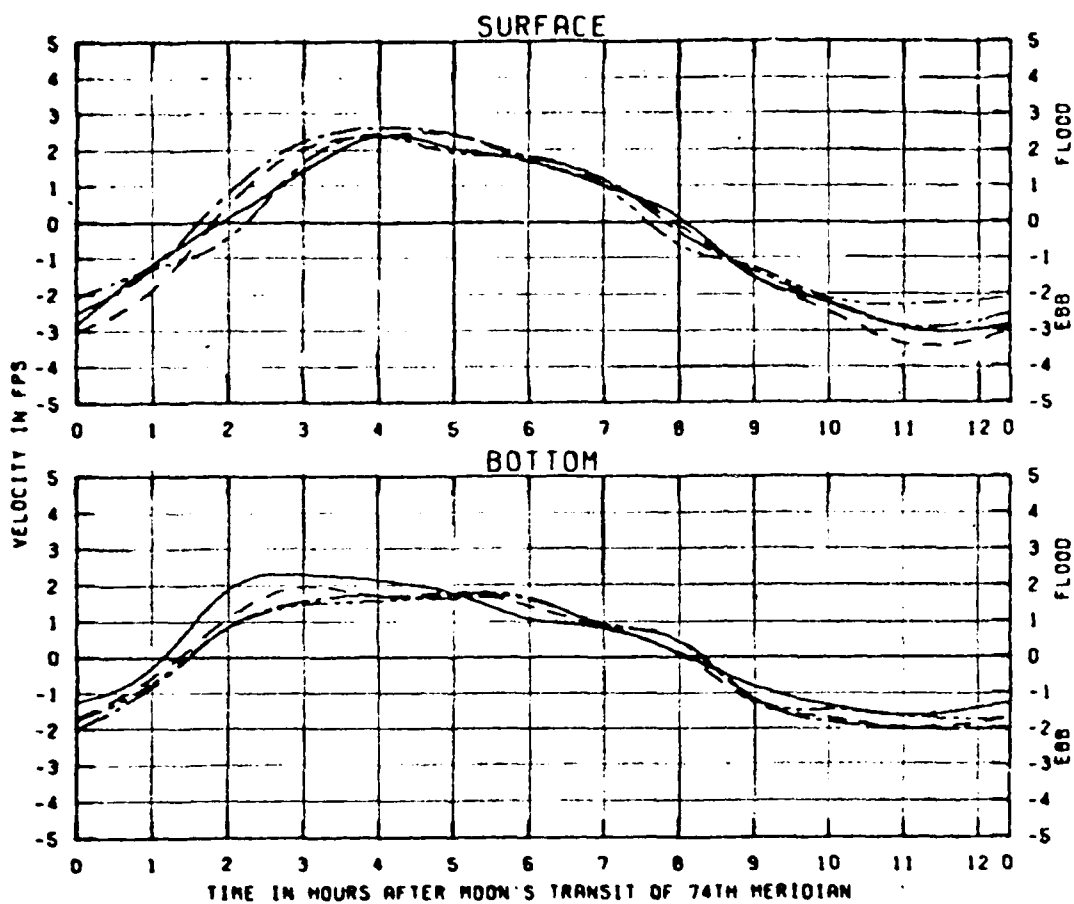

**TEST CONDITIONS**

OCEAN TIDE RANGE	5.4 FT
OCEAN SALINITY (TOTAL SALT)	30.0 PPT
BUSHY PARK COMBINED WITHDRAWALS	1150 CFS
ASHLEY RIVER	261 CFS
WANDO RIVER	82 CFS
COOPER RIVER -	VARIOUS WEEKLY HYDROGRAPHS

**LEGEND**

Sch. A	—————
Sch. B	- - - - -
Sch. E	- · - · -
Sch. BM	- · · - -

CHARLESTON HARBOR MODEL  
BUSHY PARK WATER SUPPLY TESTS

CURRENT VELOCITIES FOR  
WEEKLY HYDROGRAPH  
SCHEDULES A, B, E, AND BM  
COOPER RIVER MILE 4

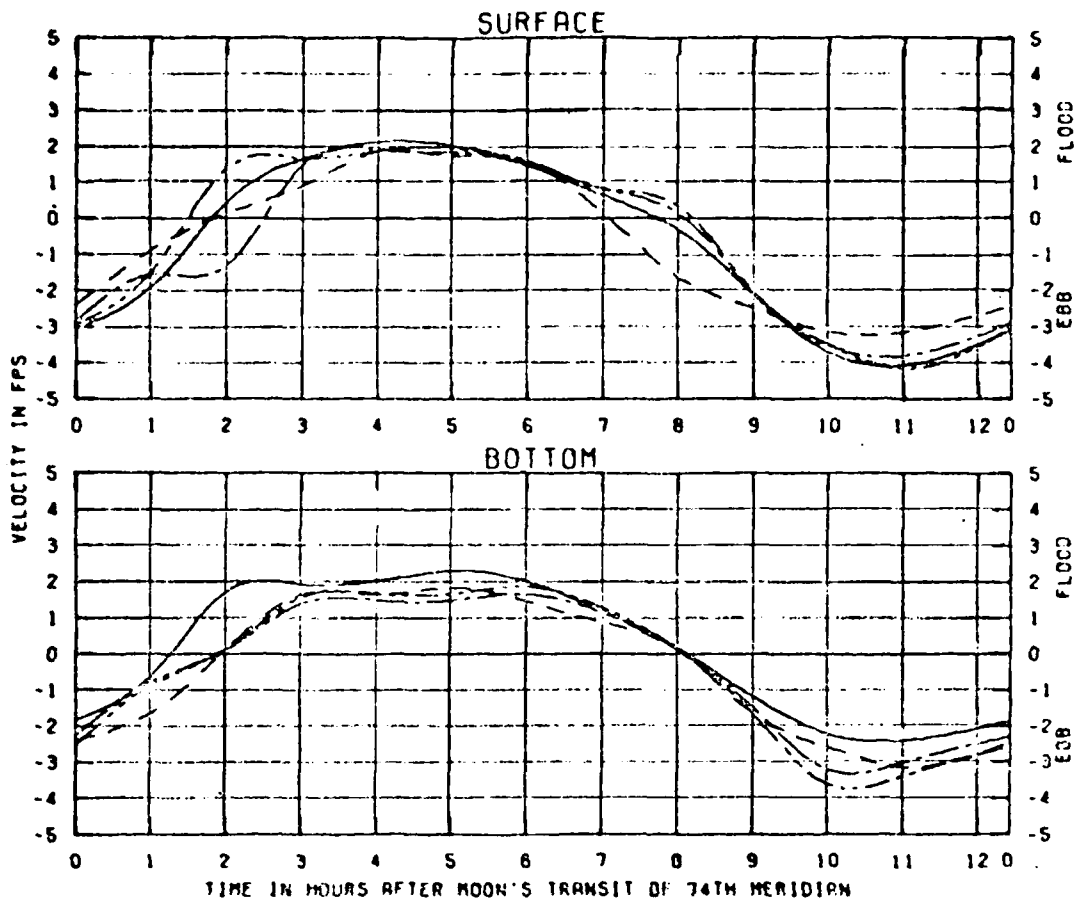

TEST CONDITIONS  
 OCEAN TIDE RANGE 5.4 FT  
 OCEAN SALINITY (TOTAL SALT) 30.0 PPT  
 BUSBY PARK COMBINED WITHORIALS 1150 CFS  
 ASHLEY RIVER 261 CFS WANDO RIVER 82 CFS  
 COOPER RIVER - VARIOUS WEEKLY HYDROGRAPHS

LEGEND  
 Sch. A ———  
 Sch. B - - - -  
 Sch. E - · - -  
 Sch. BM - · · -

CHARLESTON HARBOR MODEL  
 BUSBY PARK WATER SUPPLY TESTS

CURRENT VELOCITIES FOR  
 WEEKLY HYDROGRAPH  
 SCHEDULES A, B, E, AND BM  
 COOPER RIVER MILE 6

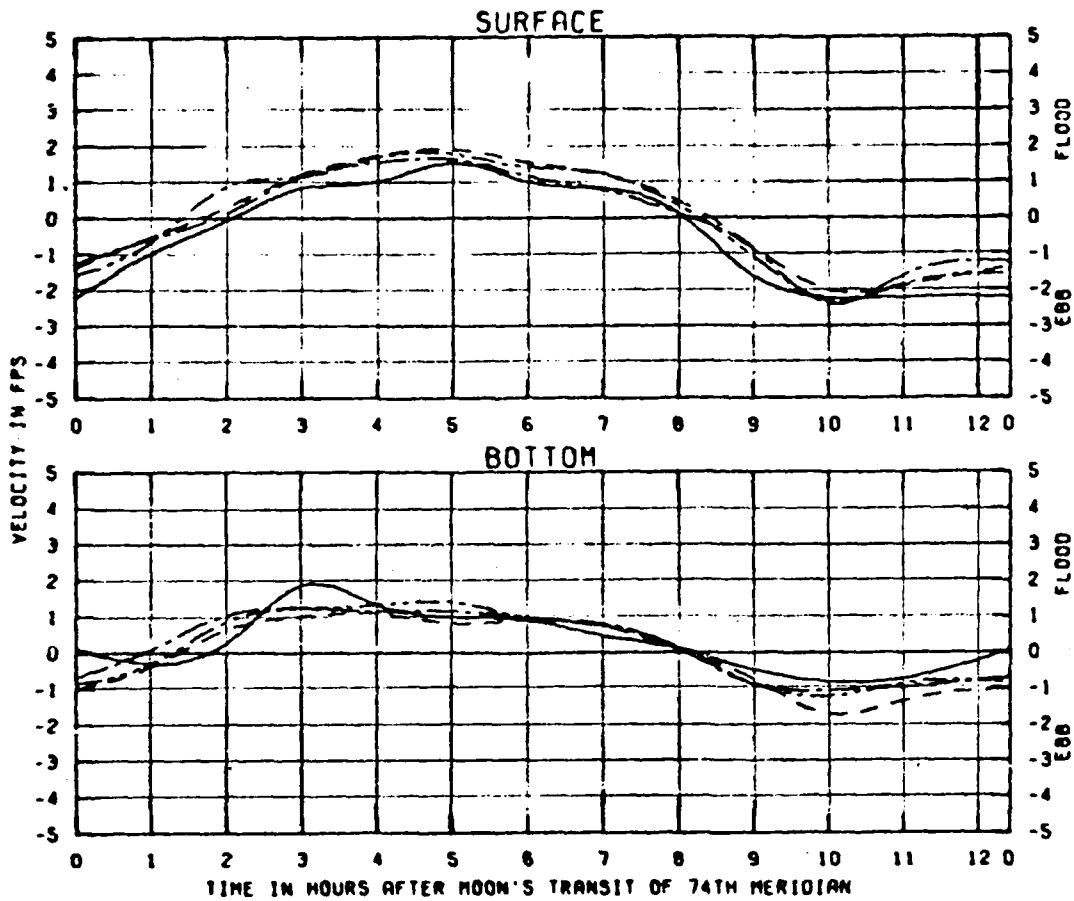

TEST CONDITIONS  
 OCEAN TIDE RANGE 5.4 FT  
 OCEAN SALINITY (TOTAL SALT) 30.0 PPT  
 BUSHY PARK COMBINED WITHDRAWALS 1150 CFS  
 ASHLEY RIVER 261 CFS WANDO RIVER 82 CFS  
 COOPER RIVER - VARIOUS WEEKLY HYDROGRAPHS

CHARLESTON HARBOR MODEL  
 BUSHY PARK WATER SUPPLY TESTS

CURRENT VELOCITIES FOR  
 WEEKLY HYDROGRAPH  
 SCHEDULES A, B, E, AND BM  
 COOPER RIVER MILE 8

LEGEND  
 Sch. A ———  
 Sch. B - - - -  
 Sch. E - . - -  
 Sch. BM - . . -

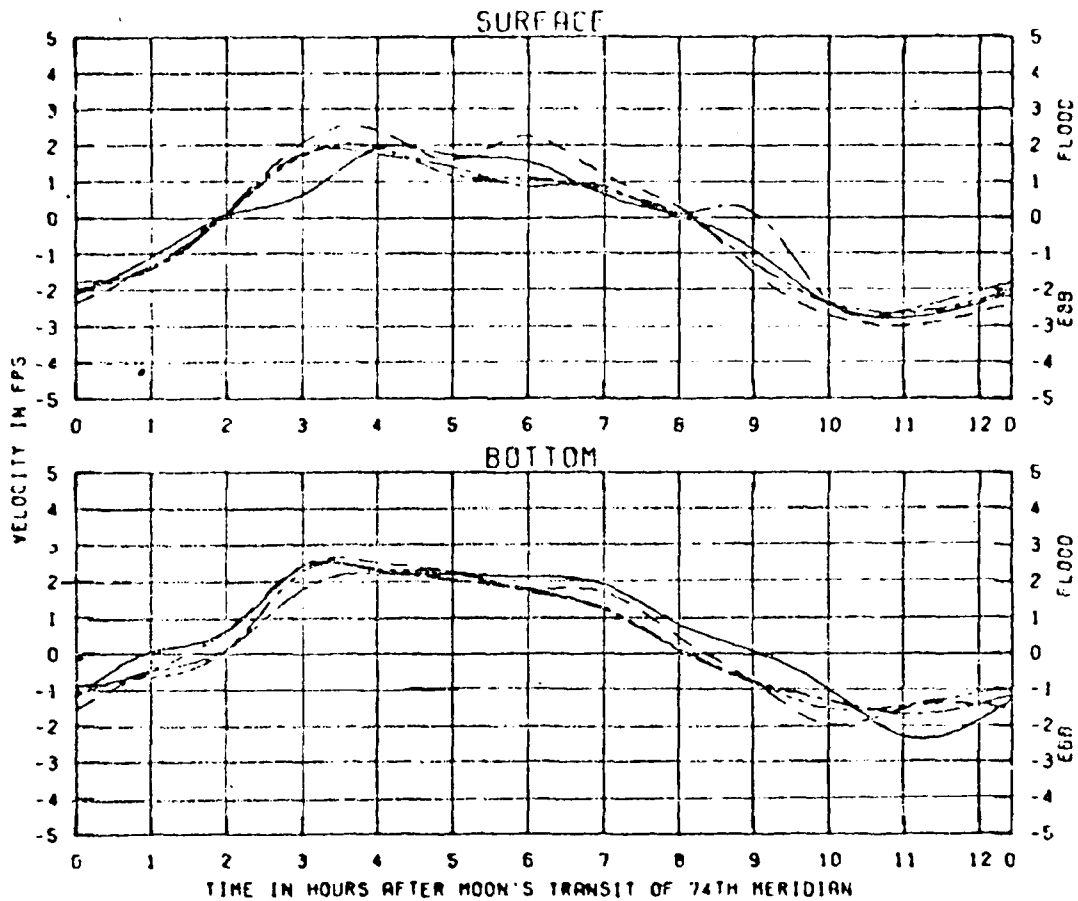

TEST CONDITIONS

OCEAN TIDE RANGE	5.4 FT
OCEAN SALINITY (TOTAL SALT)	30.0 PPT
BUSHY PARK COMBINED WITHDRAWALS	1150 CFS
ASHLEY RIVER 261 CFS	WANDO RIVER 82 CFS
COOPER RIVER -	VARIOUS WEEKLY HYDROGRAPHS

LEGEND

Sch. A	—————
Sch. B	- - - - -
Sch. E	· · · · ·
Sch. BM	- · - · -

CHARLESTON HARBOR MODEL  
BUSHY PARK WATER SUPPLY TESTS

CURRENT VELOCITIES FOR  
WEEKLY HYDROGRAPH  
SCHEDULES A, B, E, AND BM  
COOPER RIVER MILE 10

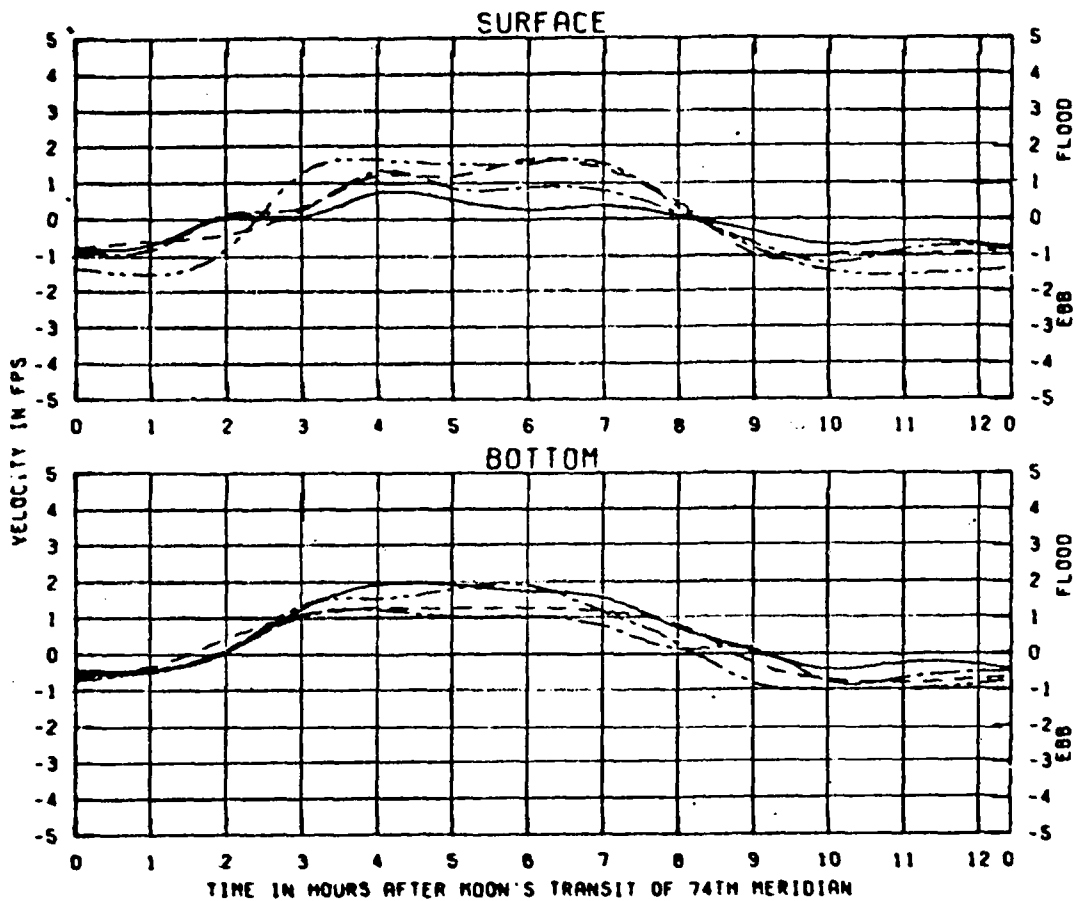

TEST CONDITIONS  
 OCEAN TIDE RANGE 5.4 FT  
 OCEAN SALINITY (TOTAL SALT) 30.0 PPT  
 BUSHY PARK COMBINED WITHDRAWALS 1150 CFS  
 ASHLEY RIVER 261 CFS WANDO RIVER 82 CFS  
 COOPER RIVER - VARIOUS WEEKLY HYDROGRAPHS

CHARLESTON HARBOR MODEL  
 BUSHY PARK WATER SUPPLY TESTS

CURRENT VELOCITIES FOR  
 WEEKLY HYDROGRAPH  
 SCHEDULES A, B, E, AND BM  
 COOPER RIVER MILE 12

LEGEND  
 Sch. A ———  
 Sch. B - - - -  
 Sch. E - . - -  
 Sch. BM - - . -

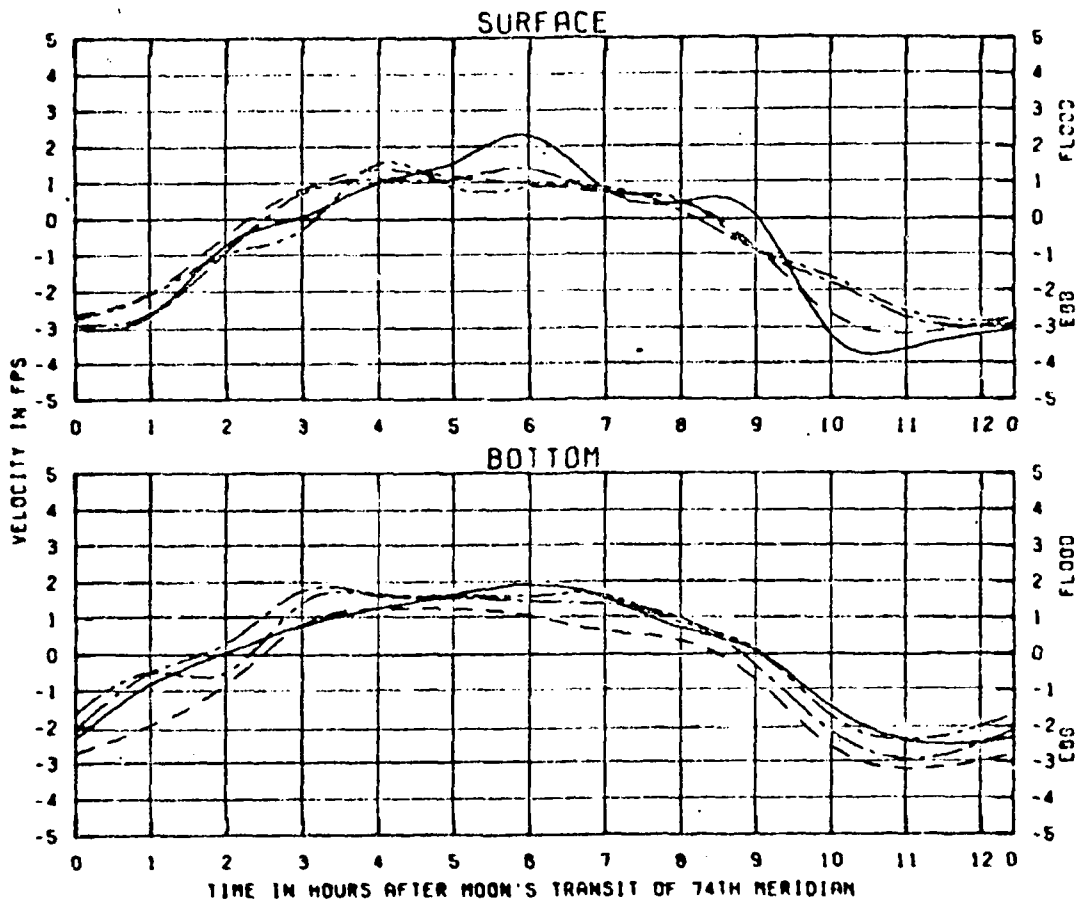

TEST CONDITIONS  
 OCEAN TIDE RANGE 5.4 FT  
 OCEAN SALINITY (TOTAL SALT) 30.0 PPT  
 BUSHY PARK COMBINED WITHDRAWALS 1150 CFS  
 ASHLEY RIVER 261 CFS WANDO RIVER 82 CFS  
 COOPER RIVER - VARIOUS WEEKLY HYDROGRAPHS

CHARLESTON HARBOR MODEL  
 BUSHY PARK WATER SUPPLY TESTS

CURRENT VELOCITIES FOR  
 WEEKLY HYDROGRAPH  
 SCHEDULES A, B, E, AND BM  
 COOPER RIVER MILE 14

LEGEND  
 Sch. A ———  
 Sch. B - - - -  
 Sch. E - · - -  
 Sch. BM - · · -

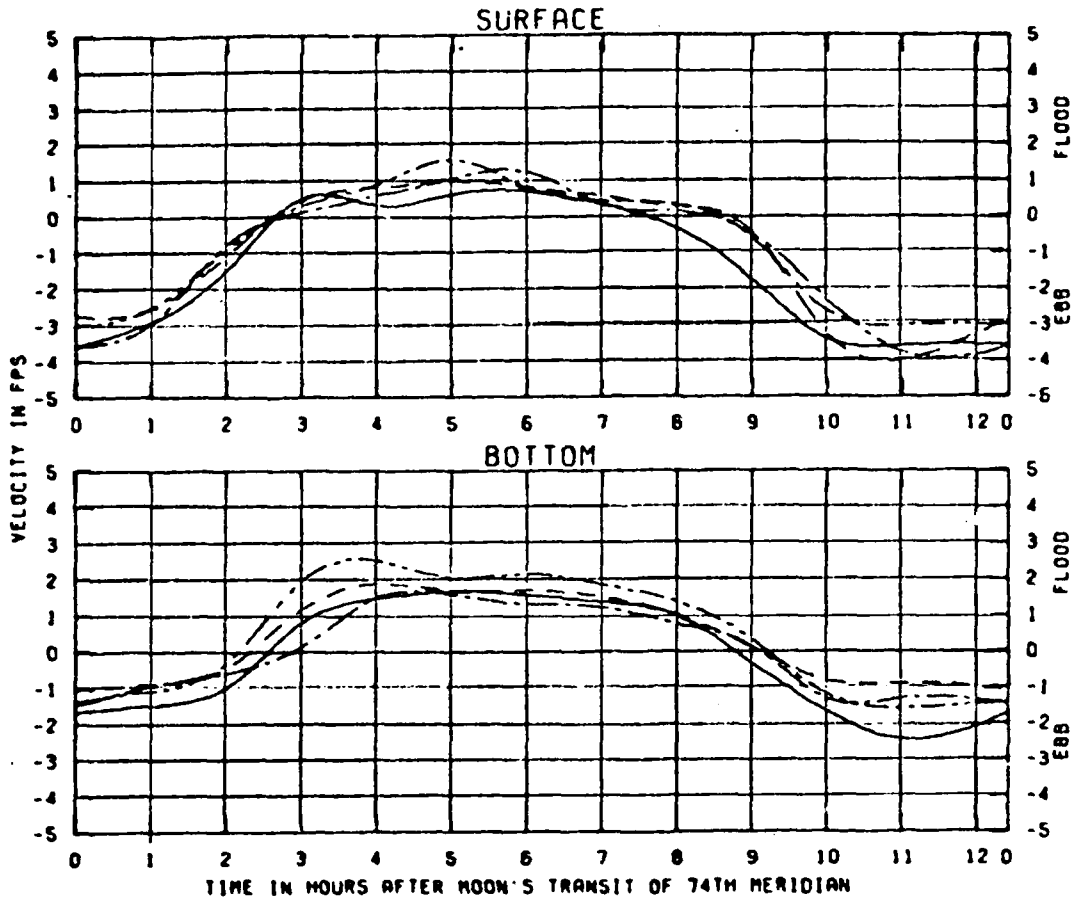

TEST CONDITIONS  
 OCEAN TIDE RANGE 5.4 FT  
 OCEAN SALINITY (TOTAL SALT) 30.0 PPT  
 BUSHY PARK COMBINED WITHDRAWALS 1150 CFS  
 ASHLEY RIVER 261 CFS WANDO RIVER 82 CFS  
 COOPER RIVER - VARIOUS WEEKLY HYDROGRAPHS

CHARLESTON HARBOR MODEL  
 BUSHY PARK WATER SUPPLY TESTS

CURRENT VELOCITIES FOR  
 WEEKLY HYDROGRAPH  
 SCHEDULES A, B, E, AND BM  
 COOPER RIVER MILE 16

LEGEND  
 Sch. A ————  
 Sch. B - - - -  
 Sch. E - . - -  
 Sch. BM - . . -

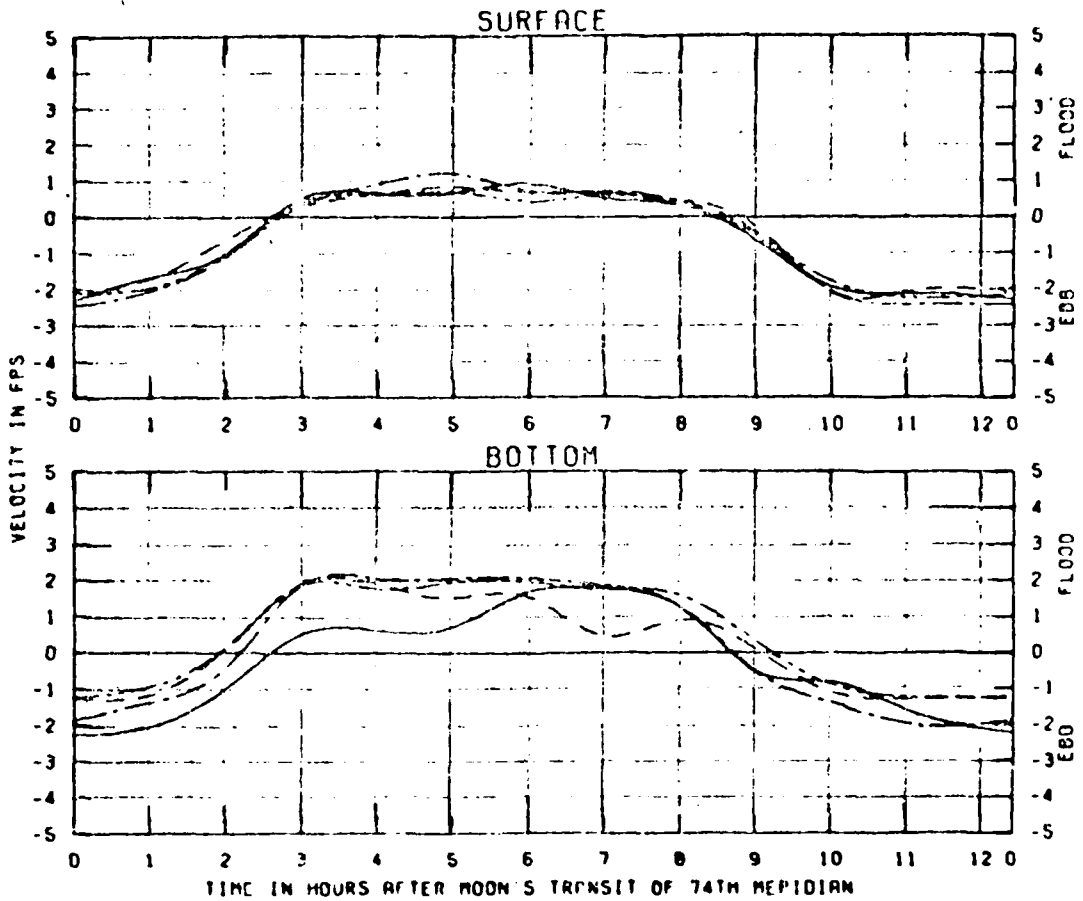

TEST CONDITIONS  
 OCEAN TIDE RANGE 5.4 FT  
 OCEAN SALINITY (TOTAL SALT) 30.0 PPT  
 BUSHY PARK COMBINED WITHDRAWALS 1150 CFS  
 ASHLEY RIVER 261 CFS WANDO RIVER 82 CFS  
 COOPER RIVER - VARIOUS WEEKLY HYDROGRAPHS

LEGEND

Sch. A ———  
 Sch. B - - - -  
 Sch. E - · - -  
 Sch. BM - · · -

CHARLESTON HARBOR MODEL  
 BUSHY PARK WATER SUPPLY TESTS

CURRENT VELOCITIES FOR  
 WEEKLY HYDROGRAPH  
 SCHEDULES A, B, E, AND BM  
 COOPER RIVER MILE 18

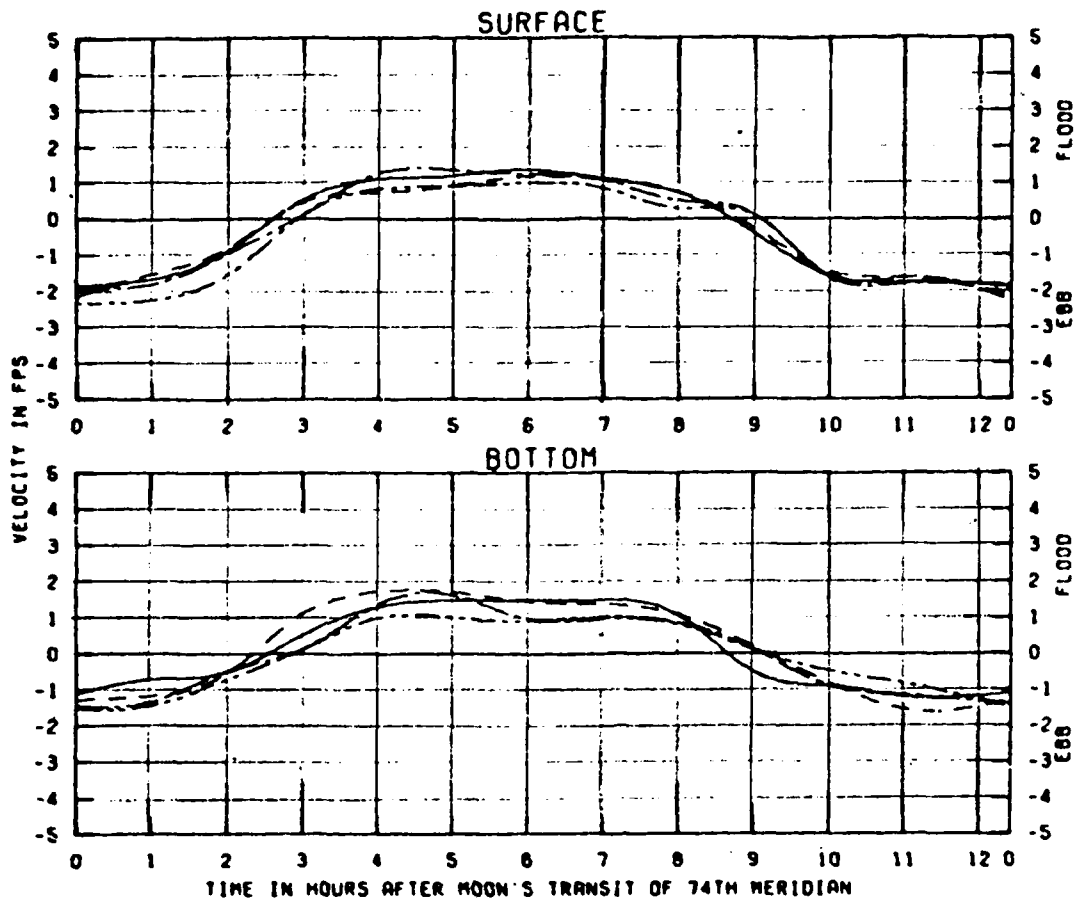

TEST CONDITIONS

OCEAN TIDE RANGE	5.4 FT
OCEAN SALINITY (TOTAL SALT)	30.0 PPT
BUSHY PARK COMBINED WITHDRAWALS	1150 CFS
ASHLEY RIVER 261 CFS	WANDO RIVER 82 CFS
COOPER RIVER -	VARIOUS WEEKLY HYDROGRAPHS

CHARLESTON HARBOR MODEL  
BUSHY PARK WATER SUPPLY TESTS

CURRENT VELOCITIES FOR  
WEEKLY HYDROGRAPH  
SCHEDULES A, B, E, AND BM  
COOPER RIVER MILE 20

LEGEND

Sch. A	—————
Sch. B	- - - - -
Sch. E	- . - . -
Sch. BM	- - - - -

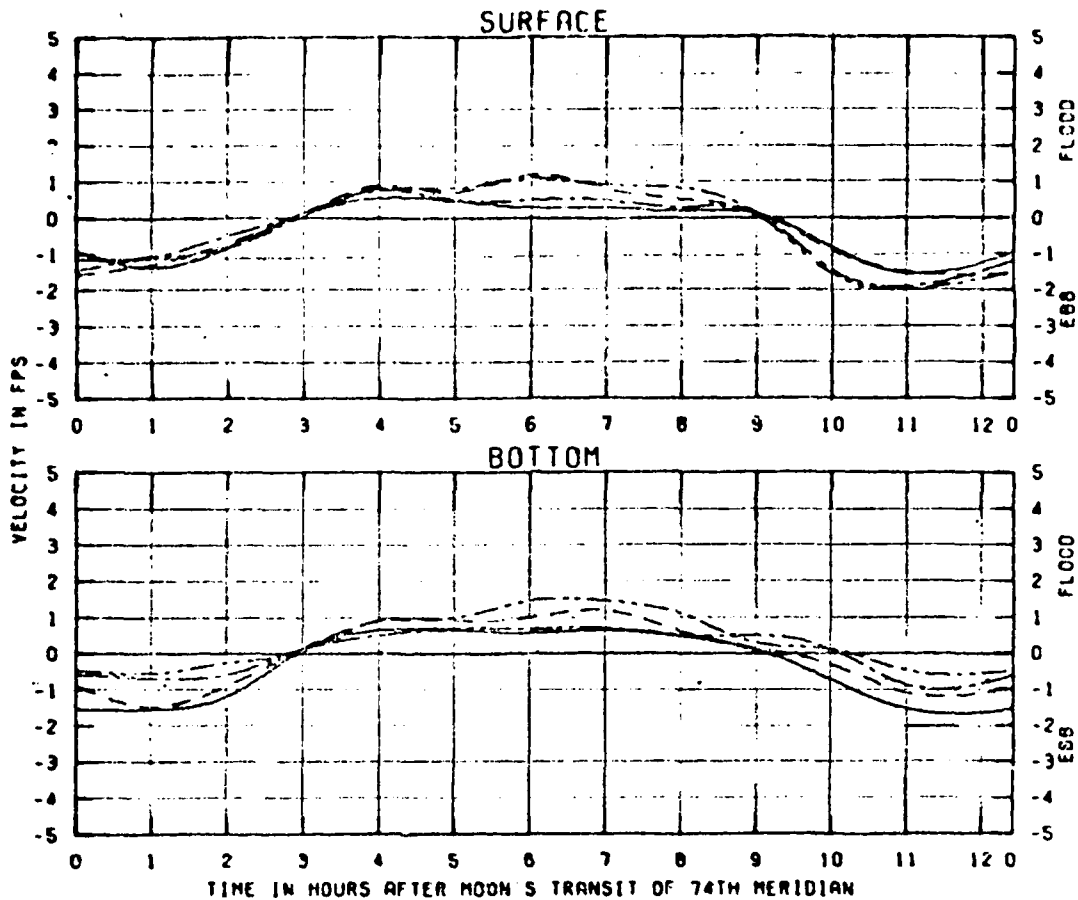

TEST CONDITIONS  
 OCEAN TIDE RANGE 5.4 FT  
 OCEAN SALINITY (TOTAL SALT) 30.0 PPT  
 BUSHY PARK COMBINED WITHDRAWALS 1150 CFS  
 ASHLEY RIVER 261 CFS WANDO RIVER 82 CFS  
 COOPER RIVER - VARIOUS WEEKLY HYDROGRAPHS

LEGEND  
 Sch. A ————  
 Sch. B - - - -  
 Sch. E — · —  
 Sch. BM — · · —

CHARLESTON HARBOR MODEL  
 BUSHY PARK WATER SUPPLY TESTS

CURRENT VELOCITIES FOR  
 WEEKLY HYDROGRAPH  
 SCHEDULES A, B, E, AND BM  
 COOPER RIVER MILE 22

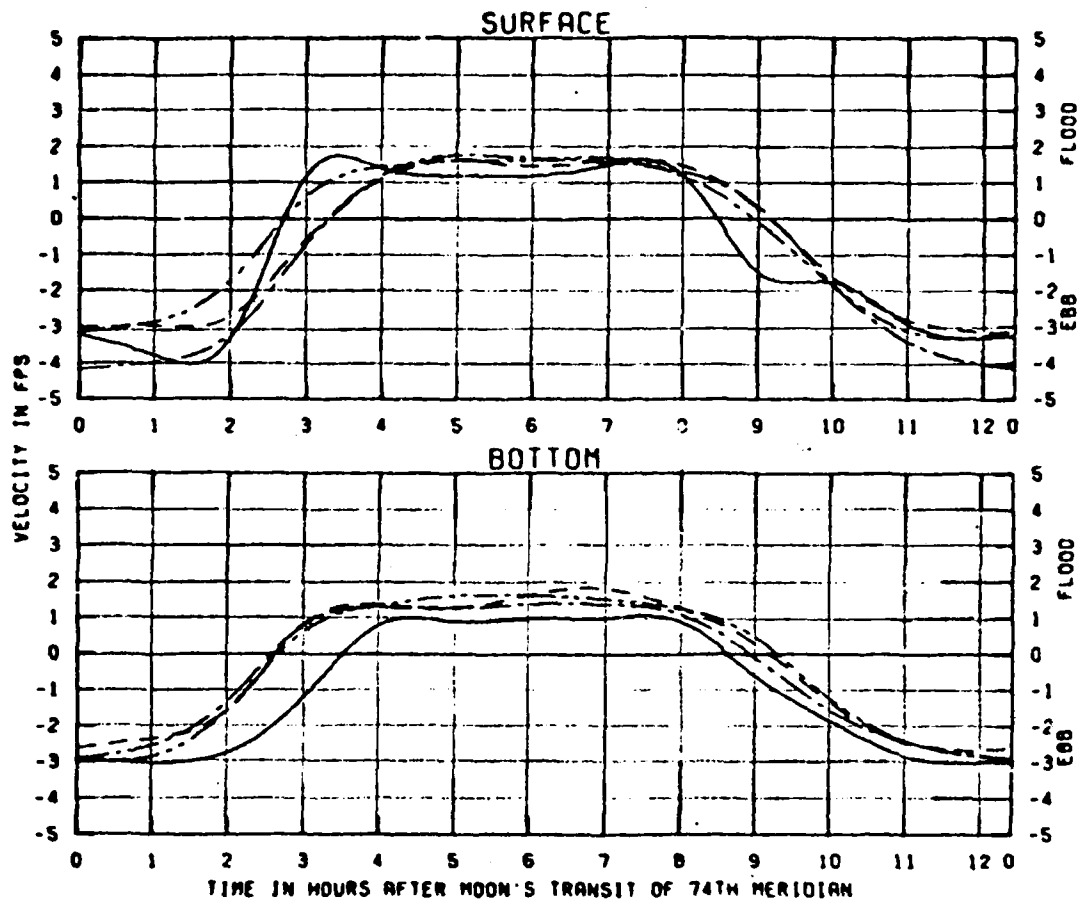

**TEST CONDITIONS**  
 OCEAN TIDE RANGE 5.4 FT  
 OCEAN SALINITY (TOTAL SALT) 30.0 PPT  
 BUSHY PARK COMBINED WITHDRAWALS 1150 CFS  
 ASHLEY RIVER 261 CFS WANDO RIVER 82 CFS  
 COOPER RIVER - VARIOUS WEEKLY HYDROGRAPHS

**LEGEND**  
 Sch. A —————  
 Sch. B - - - - -  
 Sch. E - · - - -  
 Sch. BM - · · - -

CHARLESTON HARBOR MODEL  
 BUSHY PARK WATER SUPPLY TESTS

CURRENT VELOCITIES FOR  
 WEEKLY HYDROGRAPH  
 SCHEDULES A, B, E, AND BM  
 COOPER RIVER MILE 24

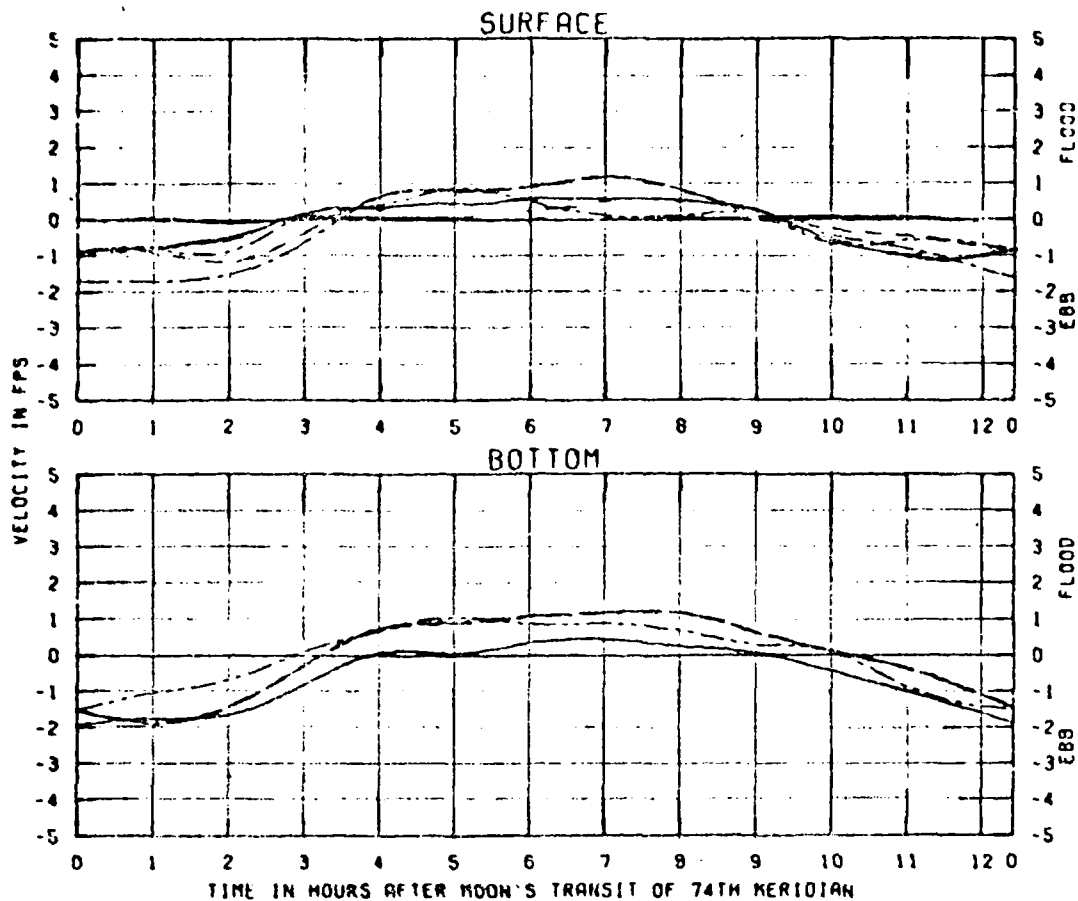

TEST CONDITIONS  
 OCEAN TIDE RANGE 5.4 FT  
 OCEAN SALINITY (TOTAL SALT) 30.0 PPT  
 BUSBY PARK COMBINED WITHDRAWALS 1150 CFS  
 ASHLEY RIVER 261 CFS WANDO RIVER 82 CFS  
 COOPER RIVER - VARIOUS WEEKLY HYDROGRAPHS

CHARLESTON HARBOR MODEL  
 BUSBY PARK WATER SUPPLY TESTS

CURRENT VELOCITIES FOR  
 WEEKLY HYDROGRAPH  
 SCHEDULES A, B, E, AND BM  
 COOPER RIVER MILE 26

LEGEND  
 Sch. A ———  
 Sch. B - - - -  
 Sch. E - · - -  
 Sch. BM - - · -

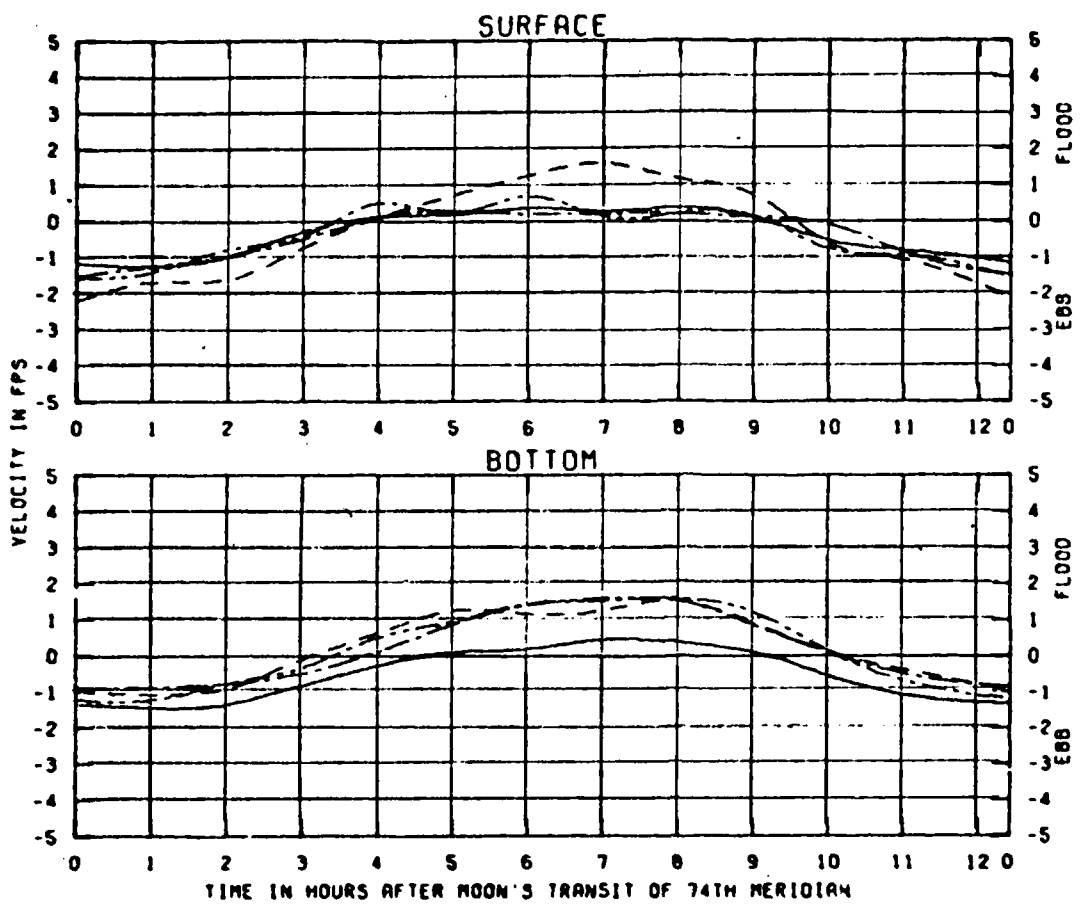

TEST CONDITIONS  
 OCEAN TIDE RANGE 5.4 FT  
 OCEAN SALINITY (TOTAL SALT) 30.0 PPT  
 BUSHY PARK COMBINED WITHDRAWALS 1150 CFS  
 ASHLEY RIVER 261 CFS WANDO RIVER 82 CFS  
 COOPER RIVER - VARIOUS WEEKLY HYDROGRAPHS

CHARLESTON HARBOR MODEL  
 BUSHY PARK WATER SUPPLY TESTS

CURRENT VELOCITIES FOR  
 WEEKLY HYDROGRAPH  
 SCHEDULES A, B, E, AND BM  
 COOPER RIVER MILE 28

LEGEND  
 Sch. A ———  
 Sch. B - - - -  
 Sch. E - · - -  
 Sch. BM - · · -

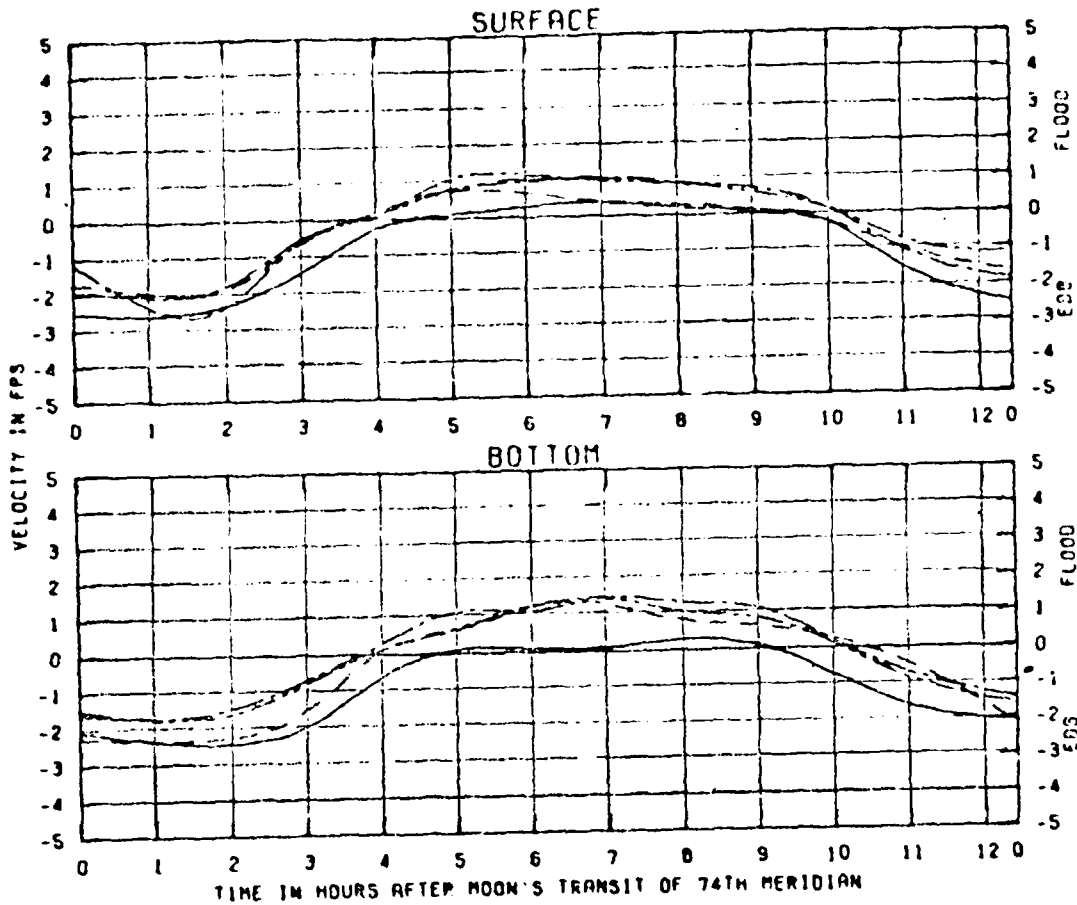

TEST CONDITIONS  
 OCEAN TIDE RANGE 6.4 FT  
 OCEAN SALINITY (TOTAL SALT) 30.0 PPT  
 BUSHY PARK COMBINED WITHDRAWALS 1150 CFS  
 ASHLEY RIVER 261 CFS WANDO RIVER 82 CFS  
 COOPER RIVER - VARIOUS WEEKLY HYDROGRAPHS

CHARLESTON HARBOR MODEL  
 BUSHY PARK WATER SUPPLY TESTS

CURRENT VELOCITIES FOR  
 WEEKLY HYDROGRAPH  
 SCHEDULES A, B, E, AND BM  
 COOPER RIVER MILE 30

LEGEND  
 Sch. A ———  
 Sch. B - - - -  
 Sch. E - · - -  
 Sch. BM - · · -

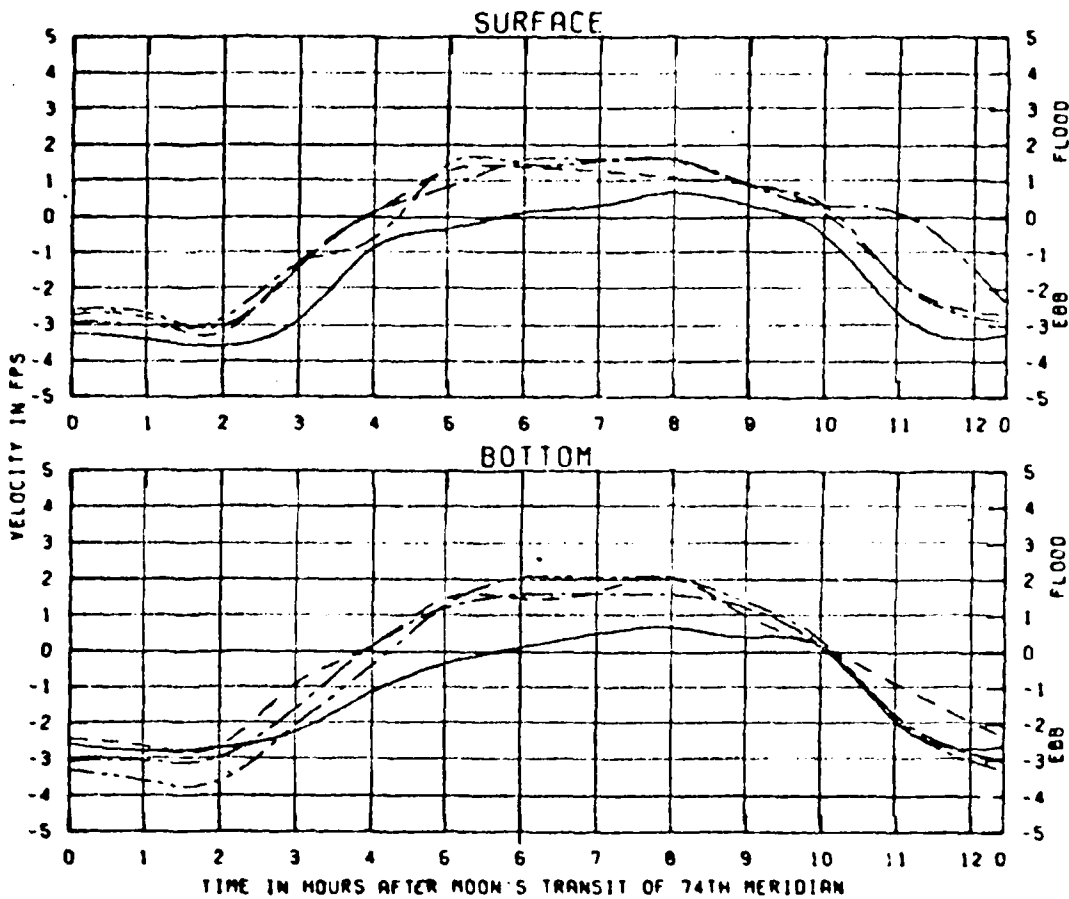

TEST CONDITIONS

OCEAN TIDE RANGE	5.4 FT
OCEAN SALINITY (TOTAL SALT)	30.0 PPT
BUSHY PARK COMBINED WITHDRAWALS	1150 CFS
ASHLEY RIVER 261 CFS	WANDO RIVER 82 CFS
COOPER RIVER -	VARIOUS WEEKLY HYDROGRAPHS

LEGEND

Sch. A	—————
Sch. B	- - - - -
Sch. E	- . - . -
Sch. BM	— . . —

CHARLESTON HARBOR MODEL  
 BUSHY PARK WATER SUPPLY TESTS  
 CURRENT VELOCITIES FOR  
 WEEKLY HYDROGRAPH  
 SCHEDULES A, B, E, AND BM  
 COOPER RIVER MILE 32

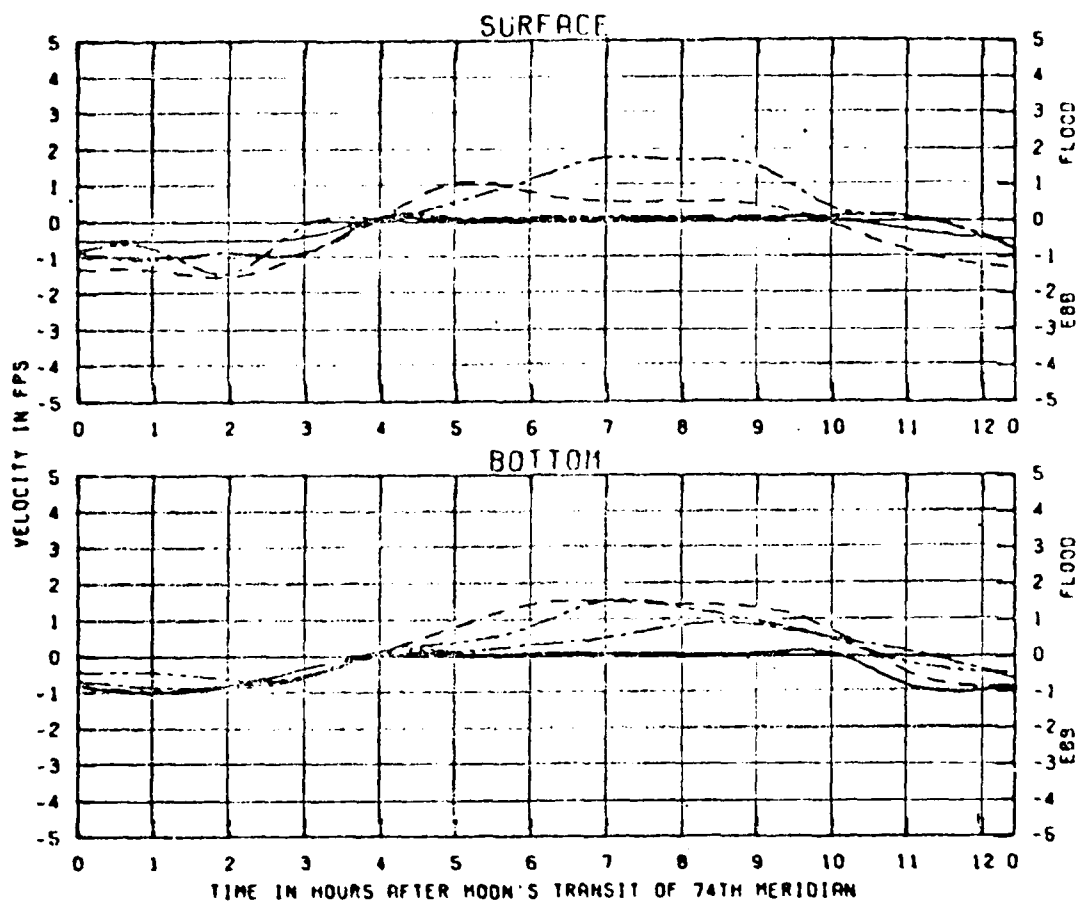

TEST CONDITIONS  
 OCEAN TIDE RANGE 5.4 FT  
 OCEAN SALINITY (TOTAL SALT) 30.0 PPT  
 BUSHY PARK COMBINED WITHDRAWALS 1150 CFS  
 ASHLEY RIVER 261 CFS MANDO RIVER 82 CFS  
 COOPER RIVER - VARIOUS WEEKLY HYDROGRAPHS

CHARLESTON HARBOR MODEL  
 BUSHY PARK WATER SUPPLY TESTS

CURRENT VELOCITIES FOR  
 WEEKLY HYDROGRAPH  
 SCHEDULES A, B, E, AND BM  
 COOPER RIVER MILE 34

LEGEND  
 Sch. A ———  
 Sch. B - - - -  
 Sch. E — · —  
 Sch. BM — · · —

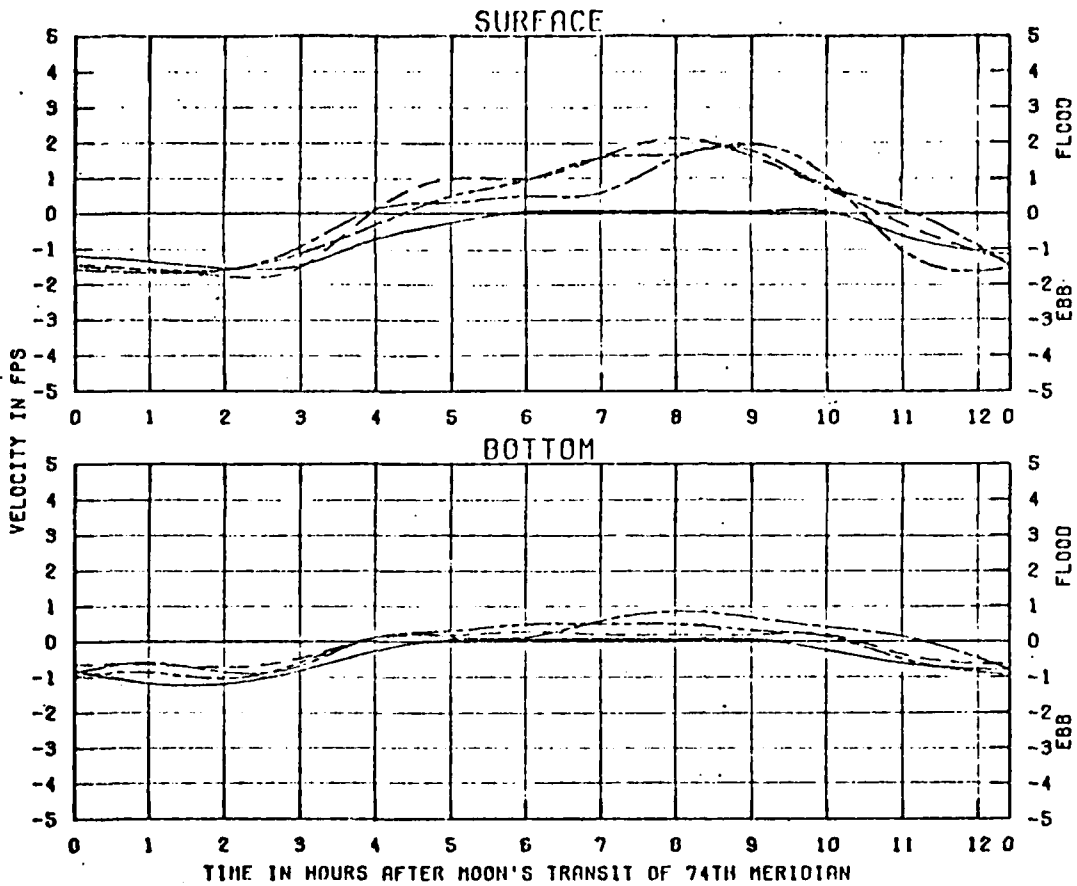

TEST CONDITIONS

OCEAN TIDE RANGE	5.4 FT
OCEAN SALINITY (TOTAL SALT)	30.0 PPT
BUSHY PARK COMBINED WITHDRAWALS	1150 CFS
ASHLEY RIVER 261 CFS	WANDO RIVER 82 CFS
COOPER RIVER -	VARIOUS WEEKLY HYDROGRAPHS

CHARLESTON HARBOR MODEL  
BUSHY PARK WATER SUPPLY TESTS

CURRENT VELOCITIES FOR  
WEEKLY HYDROGRAPH  
SCHEDULES A, B, E, AND BM  
COOPER RIVER MILE 36

LEGEND

Sch. A	—————
Sch. B	- - - - -
Sch. E	- . - . -
Sch. BM	- - - . - - -

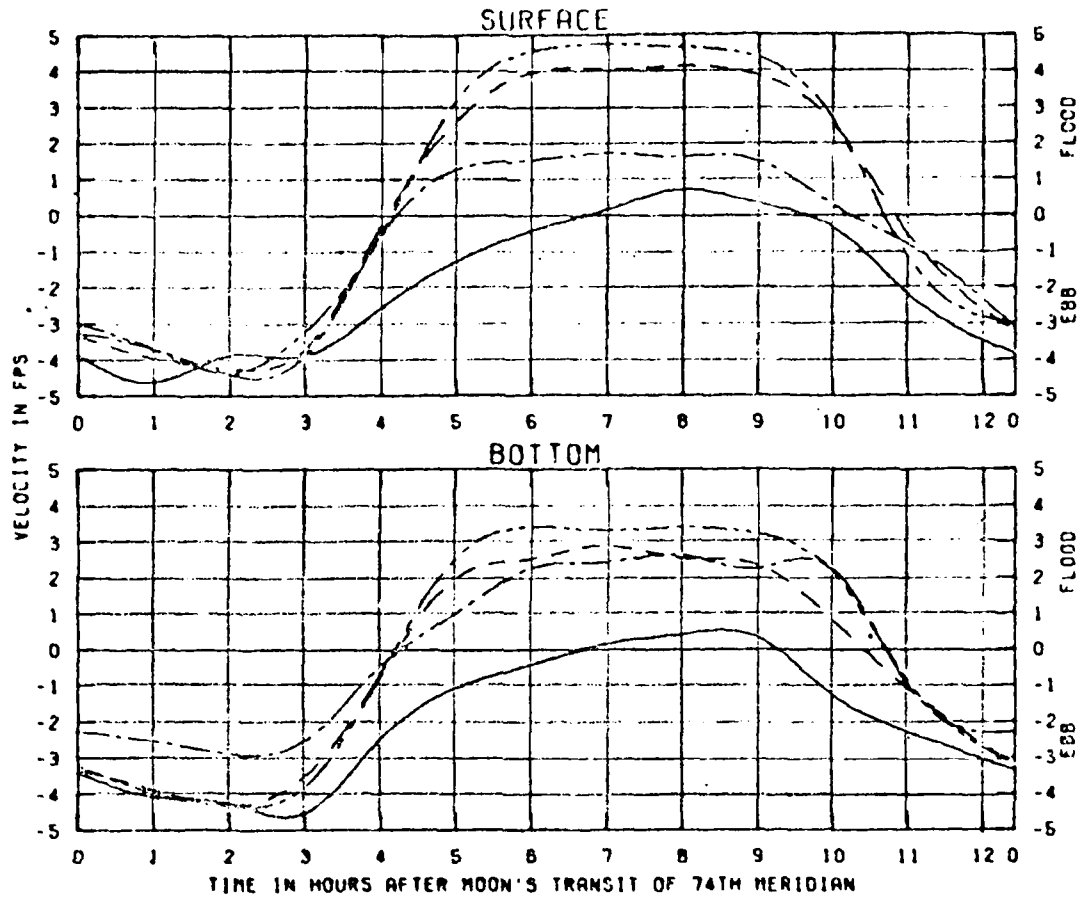

TEST CONDITIONS  
 OCEAN TIDE RANGE 5.4 FT  
 OCEAN SALINITY (TOTAL SALT) 30.0 PPT  
 BUSHY PARK COMBINED WITHDRAWALS 1150 CFS  
 ASHLEY RIVER 261 CFS WANDO RIVER 82 CFS  
 COOPER RIVER - VARIOUS WEEKLY HYDROGRAPHS

LEGEND  
 Sch. A ———  
 Sch. B - - - -  
 Sch. E - · - -  
 Sch. BM - - · -

CHARLESTON HARBOR MODEL  
 BUSHY PARK WATER SUPPLY TESTS

CURRENT VELOCITIES FOR  
 WEEKLY HYDROGRAPH  
 SCHEDULES A, B, E, AND BM  
 COOPER RIVER MILE 38

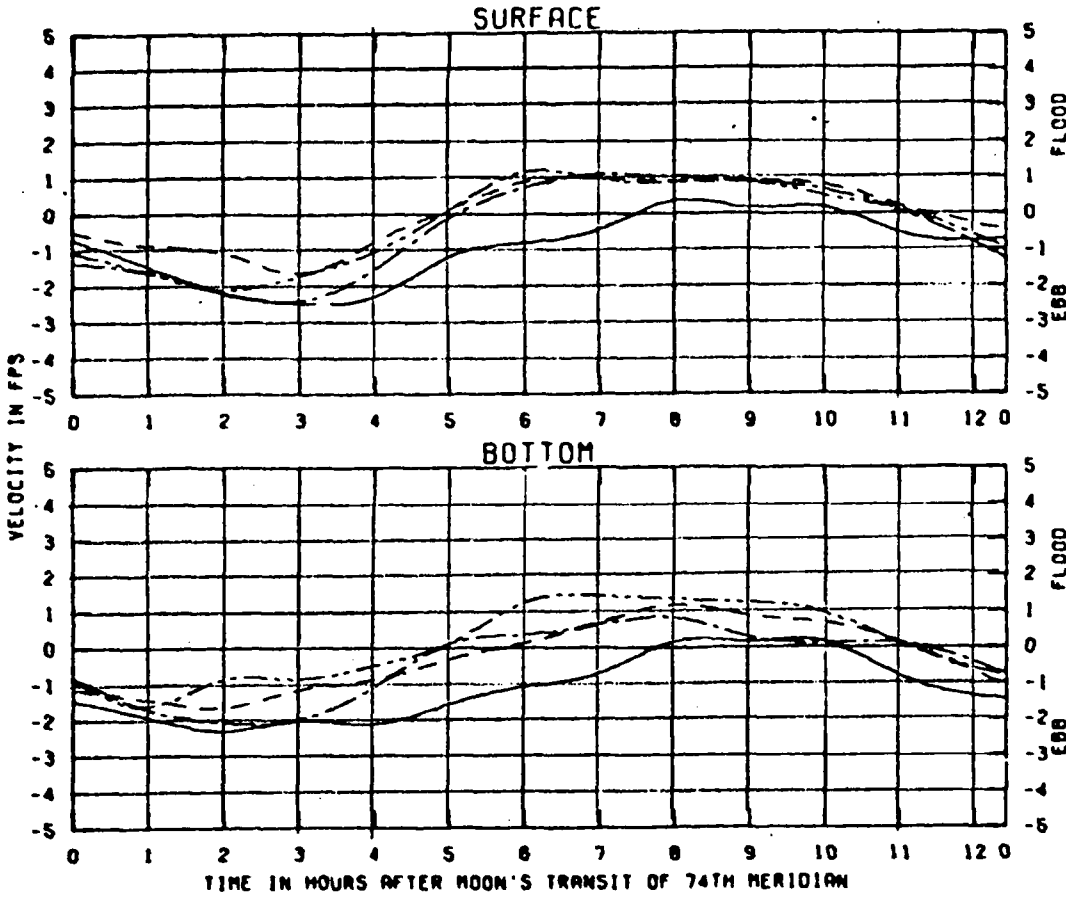

TEST CONDITIONS  
 OCEAN TIDE RANGE 5.4 FT  
 OCEAN SALINITY (TOTAL SALT) 30.0 PPT  
 BUSBY PARK COMBINED WITHDRAWALS 1150 CFS  
 ASHLEY RIVER 261 CFS WANDO RIVER 82 CFS  
 COOPER RIVER - VARIOUS WEEKLY HYDROGRAPHS

CHARLESTON HARBOR MODEL  
 BUSBY PARK WATER SUPPLY TESTS

CURRENT VELOCITIES FOR  
 WEEKLY HYDROGRAPH  
 SCHEDULES A, B, E, AND BM  
 COOPER RIVER MILE 40

LEGEND  
 Sch. A ———  
 Sch. B - - - -  
 Sch. E - . - -  
 Sch. BM - . . -

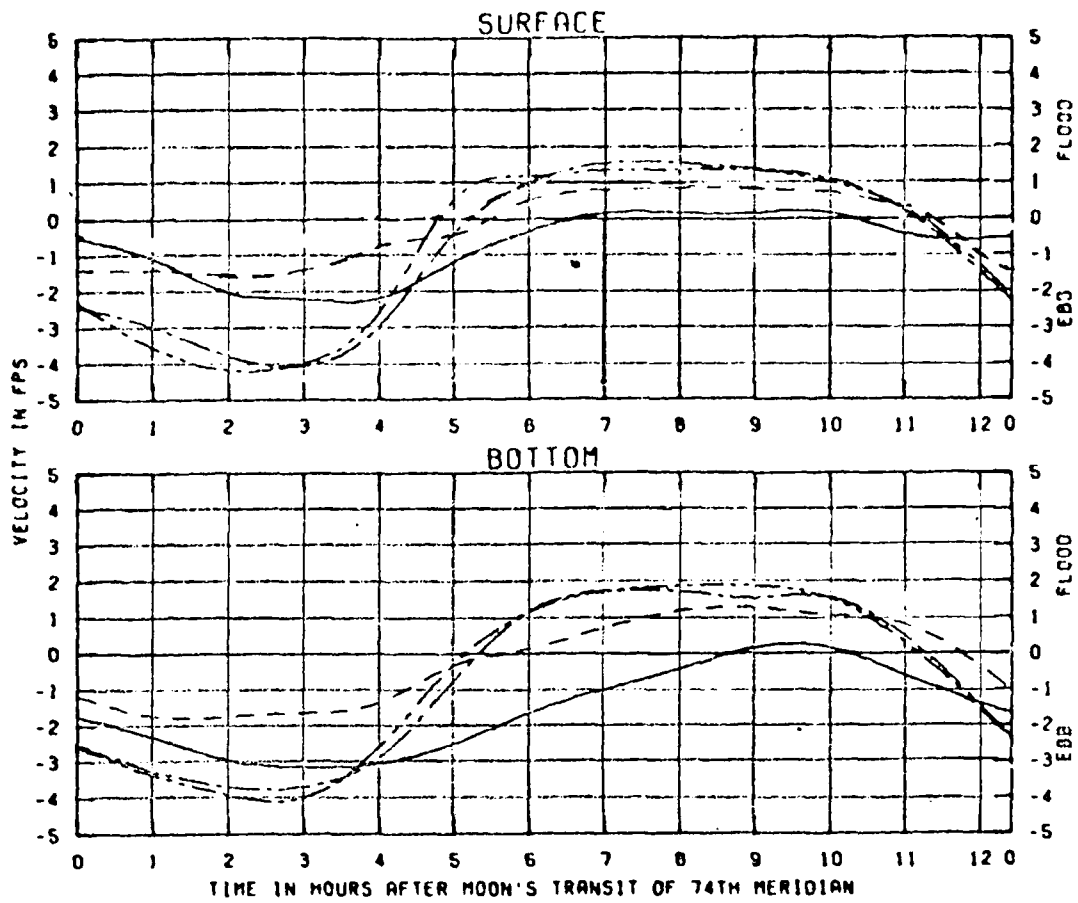

TEST CONDITIONS  
 OCEAN TIDE RANGE 5.4 FT  
 OCEAN SALINITY (TOTAL SALT) 30.0 PPT  
 BUSHY PARK COMBINED WITHDRAWALS 1150 CFS  
 ASHLEY RIVER 261 CFS WANDO RIVER 82 CFS  
 COOPER RIVER - VARIOUS WEEKLY HYDROGRAPHS

LEGEND  
 Sch. A —————  
 Sch. B - - - - -  
 Sch. E - · - -  
 Sch. BM - · · -

CHARLESTON HARBOR MODEL  
 BUSHY PARK WATER SUPPLY TESTS

CURRENT VELOCITIES FOR  
 WEEKLY HYDROGRAPH  
 SCHEDULES A, B, E, AND BM  
 COOPER RIVER MILE 42

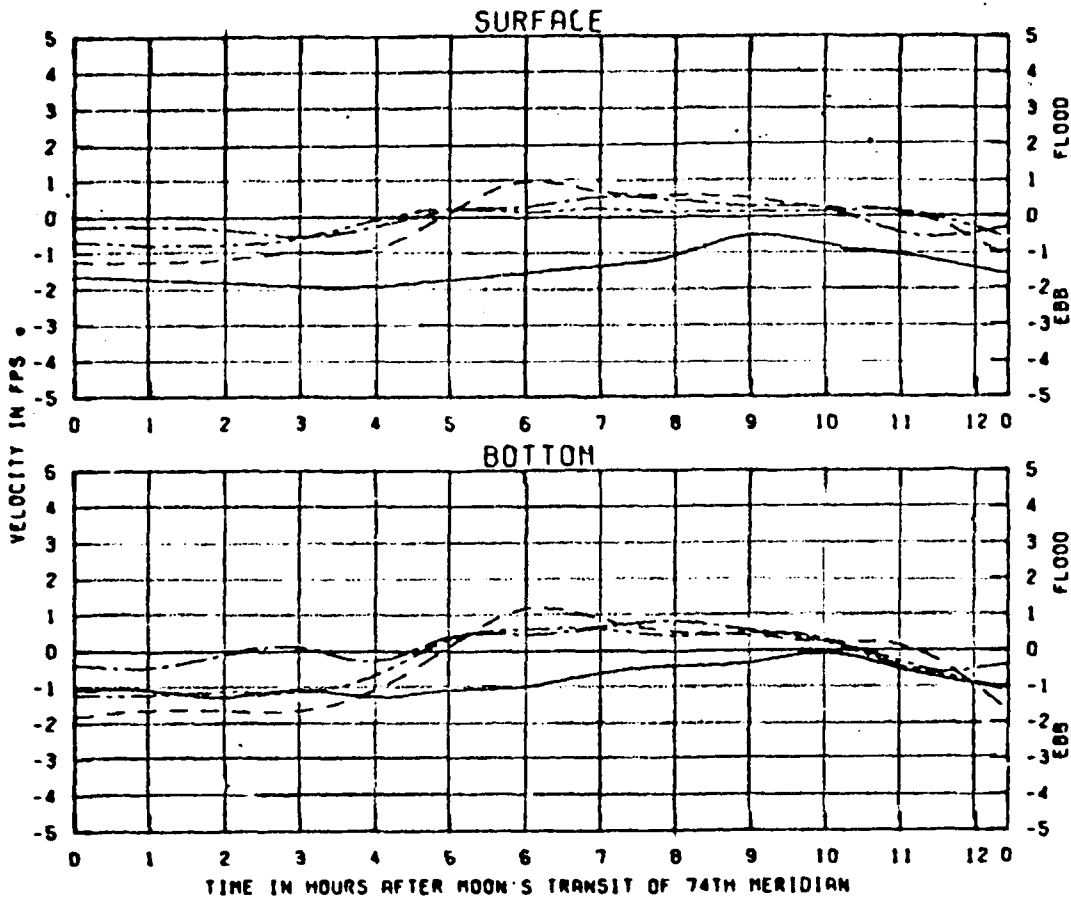

**TEST CONDITIONS**

OCEAN TIDE RANGE 5.4 FT  
 OCEAN SALINITY (TOTAL SALT) 30.0 PPT  
 BUSHY PARK COMBINED WITHDRAWALS 1150 CFS  
 ASHLEY RIVER 261 CFS WANDO RIVER 82 CFS  
 COOPER RIVER - VARIOUS WEEKLY HYDROGRAPHS

CHARLESTON HARBOR MODEL  
 BUSHY PARK WATER SUPPLY TESTS

CURRENT VELOCITIES FOR  
 WEEKLY HYDROGRAPH  
 SCHEDULES A, B, E, AND BM  
 COOPER RIVER MILE 44

**LEGEND**

Sch. A ————  
 Sch. B - - - -  
 Sch. E — · —  
 Sch. BM — · · —

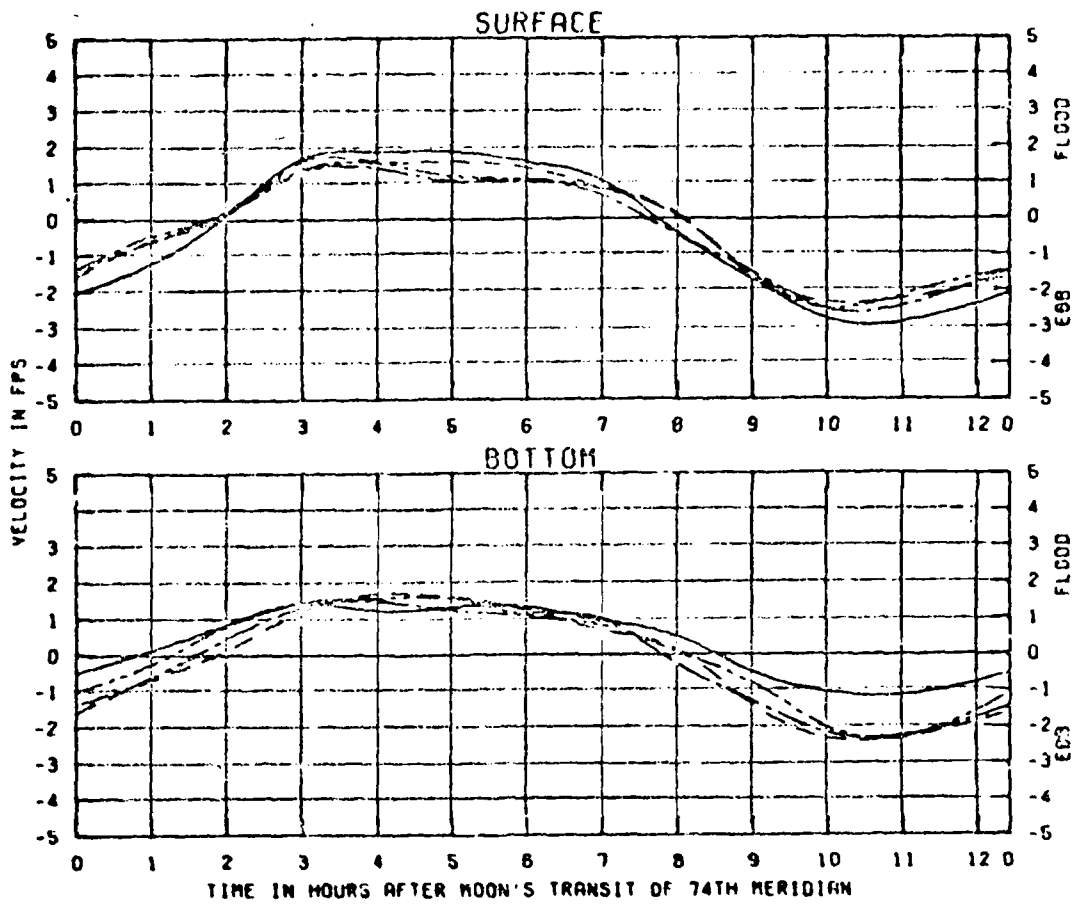

TEST CONDITIONS  
 OCEAN TIDE RANGE 5.4 FT  
 OCEAN SALINITY (TOTAL SALT) 30.0 PPT  
 BUSHY PARK COMBINED WITHDRAWALS 1150 CFS  
 ASHLEY RIVER 261 CFS WANDO RIVER 82 CFS  
 COOPER RIVER - VARIOUS WEEKLY HYDROGRAPHS

LEGEND  
 Sch. A ———  
 Sch. B - - - -  
 Sch. E - · - -  
 Sch. BM · · · ·

CHARLESTON HARBOR MODEL  
 BUSHY PARK WATER SUPPLY TESTS

CURRENT VELOCITIES FOR  
 WEEKLY HYDROGRAPH  
 SCHEDULES A, B, E, AND BM  
 WANDO RIVER MILE 1

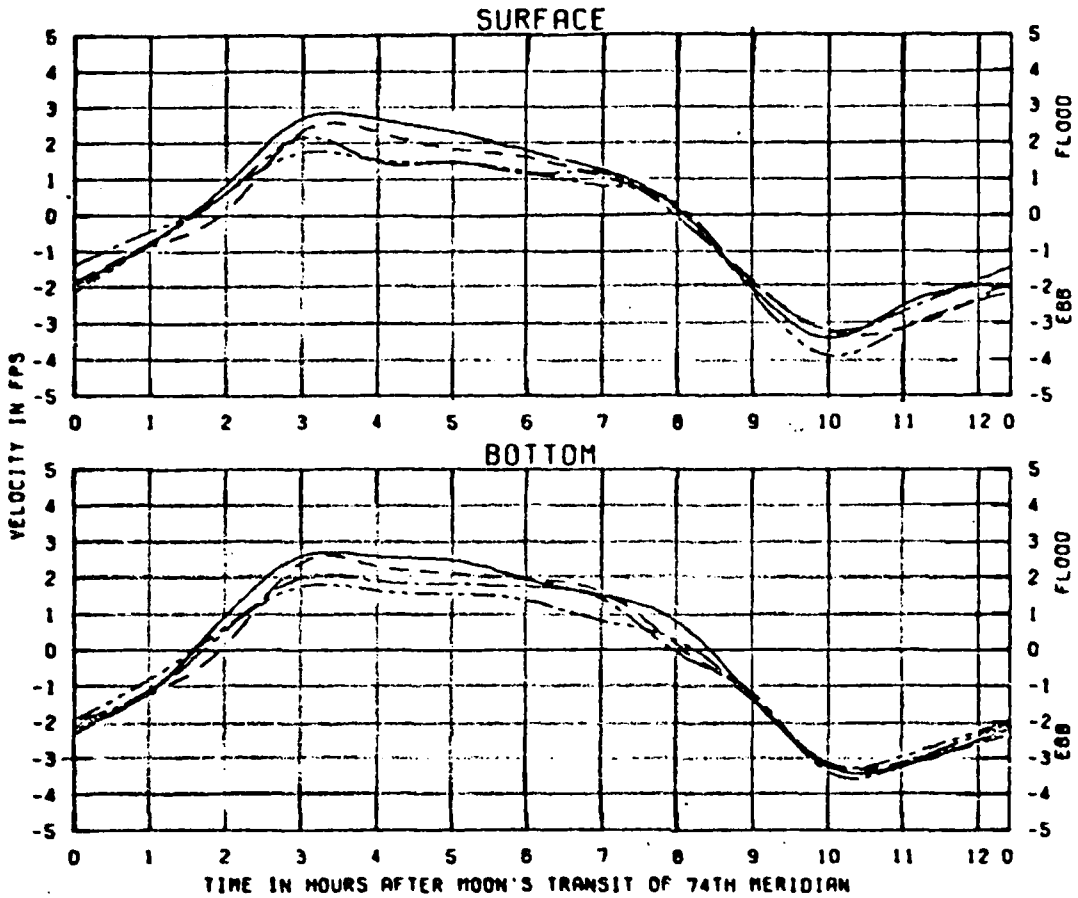

TEST CONDITIONS  
 OCEAN TIDE RANGE 5.4 FT  
 OCEAN SALINITY (TOTAL SALT) 30.0 PPT  
 BUSHY PARK COMBINED WITHDRAWALS 1150 CFS  
 ASHLEY RIVER 261 CFS WANDO RIVER 82 CFS  
 COOPER RIVER - VARIOUS WEEKLY HYDROGRAPHS

LEGEND  
 Sch. A ———  
 Sch. B - - - -  
 Sch. E - . - -  
 Sch. BM - - . -

CHARLESTON HARBOR MODEL  
 BUSHY PARK WATER SUPPLY TESTS

CURRENT VELOCITIES FOR  
 WEEKLY HYDROGRAPH  
 SCHEDULES A, B, E, AND BM  
 WANDO RIVER MILE 3

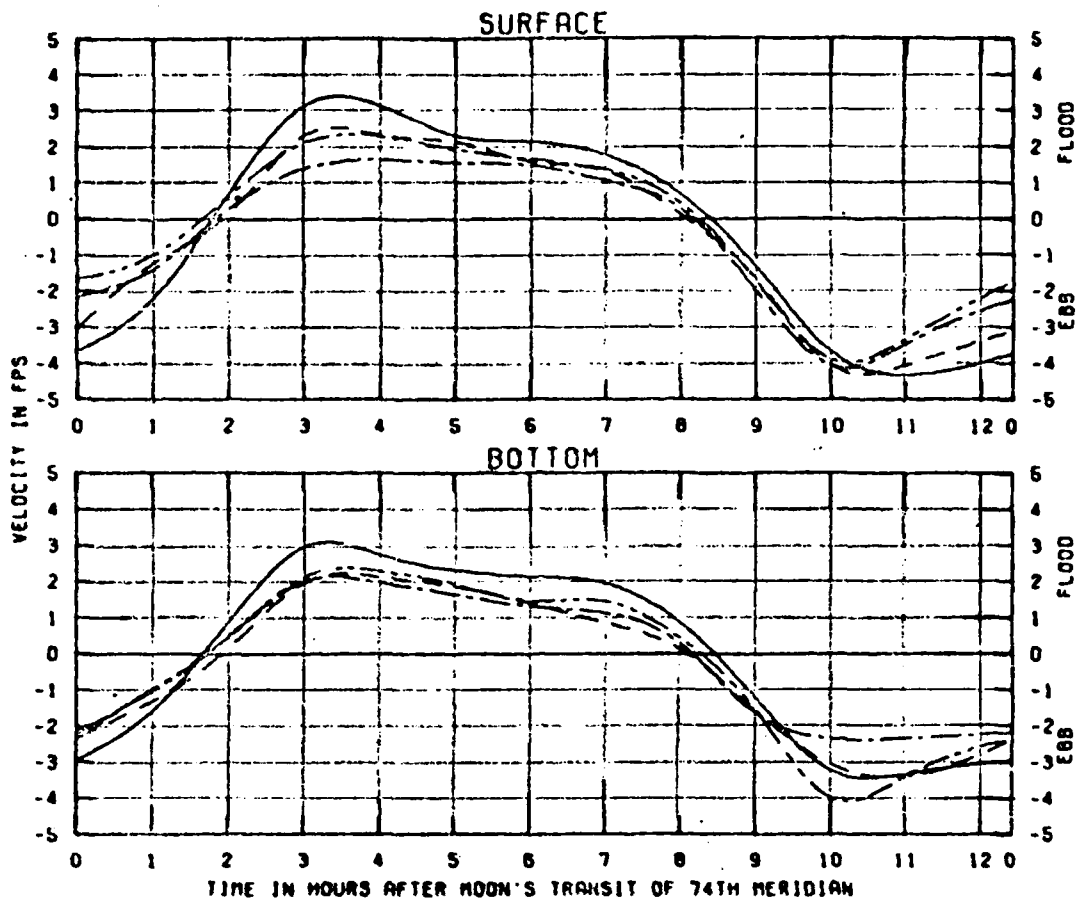

**TEST CONDITIONS**

OCEAN TIDE RANGE	5.4 FT
OCEAN SALINITY (TOTAL SALT)	30.0 PPT
BUSHY PARK COMBINED WITHDRAWALS	1150 CFS
ASHLEY RIVER 261 CFS	WANDO RIVER 82 CFS
COOPER RIVER -	VARIOUS WEEKLY HYDROGRAPHS

**LEGEND**

Sch. A —————

Sch. B - - - - -

Sch. E - · - -

Sch. BM - · · -

CHARLESTON HARBOR MODEL  
BUSHY PARK WATER SUPPLY TESTS

CURRENT VELOCITIES FOR  
WEEKLY HYDROGRAPH  
SCHEDULES A, B, E, AND BM  
WANDO RIVER MILE 5

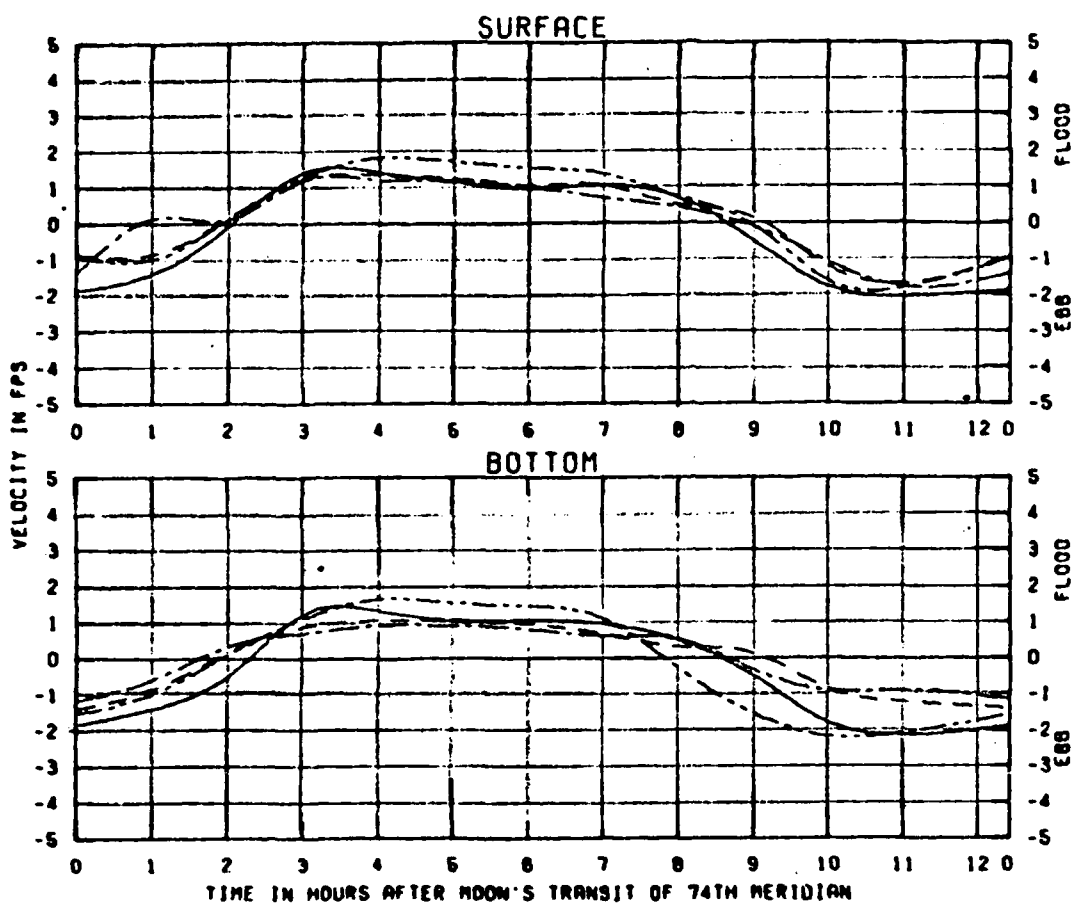

TEST CONDITIONS  
 OCEAN TIDE RANGE 5.4 FT  
 OCEAN SALINITY (TOTAL SALT) 30.0 PPT  
 BUSHY PARK COMBINED WITHDRAWALS 1160 CFS  
 ASHLEY RIVER 261 CFS WANDO RIVER 82 CFS  
 COOPER RIVER - VARIOUS WEEKLY HYDROGRAPHS

LEGEND  
 Sch. A ———  
 Sch. B - - - -  
 Sch. E — · —  
 Sch. BM - · · -

CHARLESTON HARBOR MODEL  
 BUSHY PARK WATER SUPPLY TESTS

CURRENT VELOCITIES FOR  
 WEEKLY HYDROGRAPH  
 SCHEDULES A, B, E, AND BM  
 WANDO RIVER MILE 7

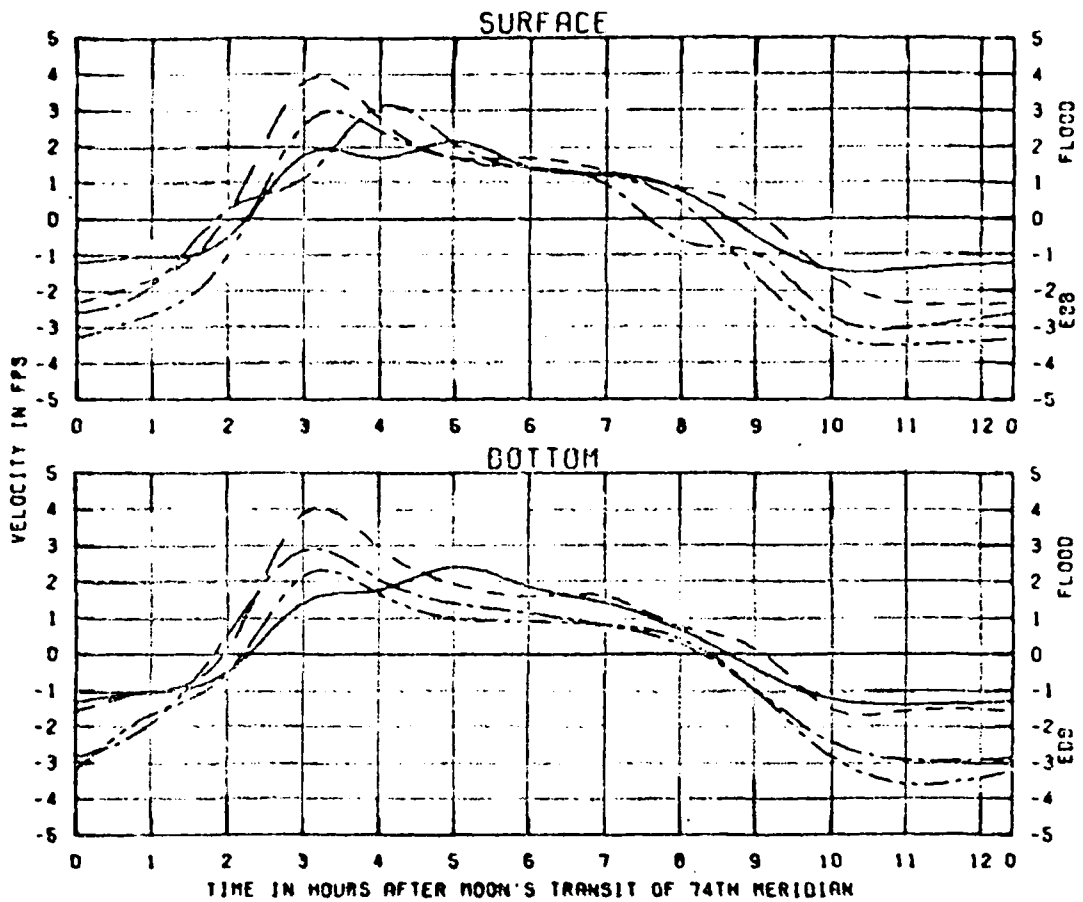

TEST CONDITIONS

OCEAN TIDE RANGE	5.4 FT
OCEAN SALINITY (TOTAL SALT)	30.0 PPT
BUSBY PARK COMBINED WITHDRAWALS	1150 CFS
ASHLEY RIVER 261 CFS	WANDO RIVER 82 CFS
COOPER RIVER -	VARIOUS WEEKLY HYDROGRAPHS

LEGEND

Sch. A	—————
Sch. B	- - - - -
Sch. E	— · —
Sch. BM	- · · -

CHARLESTON HARBOR MODEL  
BUSBY PARK WATER SUPPLY TESTS

CURRENT VELOCITIES FOR  
WEEKLY HYDROGRAPH  
SCHEDULES A, B, E, AND BM  
WANDO RIVER MILE 9

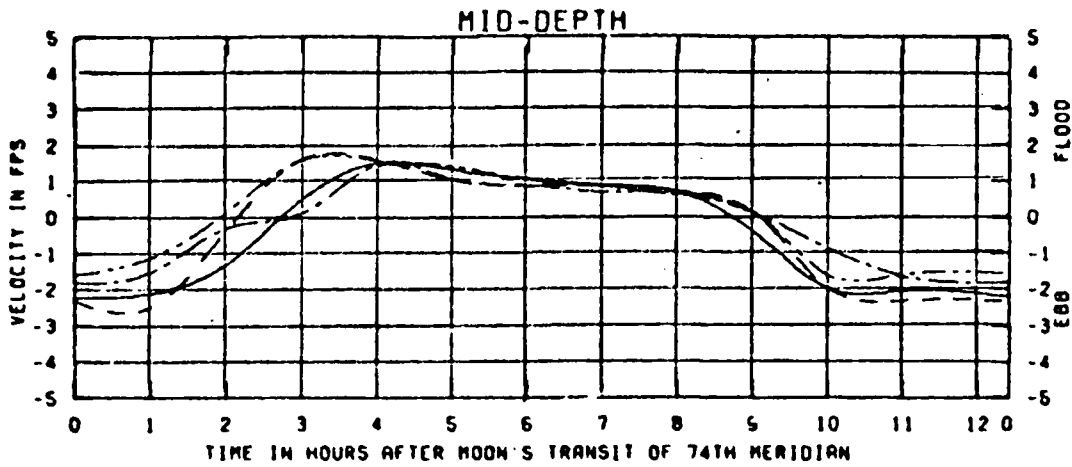

**TEST CONDITIONS**

OCEAN TIDE RANGE	5.4 FT
OCEAN SALINITY (TOTAL SALT)	30.0 PPT
BUSHY PARK COMBINED WITHDRAWALS	1150 CFS
ASHLEY RIVER 261 CFS	WANDO RIVER 82 CFS
COOPER RIVER -	VARIOUS WEEKLY HYDROGRAPHS

**LEGEND**

Sch. A	—————
Sch. B	- - - - -
Sch. E	— · —
Sch. BM	— · · —

**CHARLESTON HARBOR MODEL  
BUSHY PARK WATER SUPPLY TESTS**

**CURRENT VELOCITIES FOR  
WEEKLY HYDROGRAPH  
SCHEDULES A, B, E, AND BM  
WANDO RIVER MILE 13**

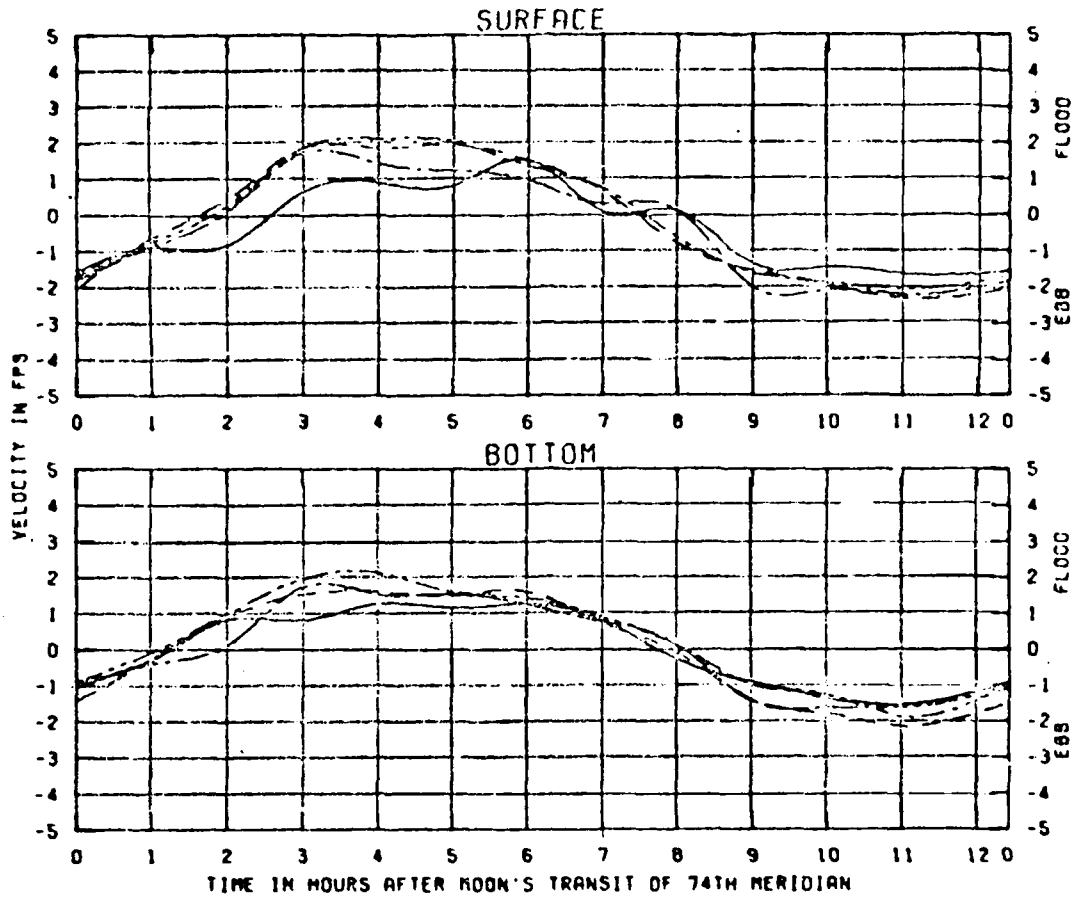

TEST CONDITIONS

OCEAN TIDE RANGE	5.4 FT
OCEAN SALINITY (TOTAL SALT)	30.0 PPT
BUSHY PARK COMBINED WITHDRAWALS	1150 CFS
ASHLEY RIVER 261 CFS	MANDO RIVER 82 CFS
COOPER RIVER -	VARIOUS WEEKLY HYDROGRAPHS

LEGEND

Sch. A	—————
Sch. B	- - - - -
Sch. E	— · —
Sch. BM	— · · —

CHARLESTON HARBOR MODEL  
BUSHY PARK WATER SUPPLY TESTS

CURRENT VELOCITIES FOR  
WEEKLY HYDROGRAPH  
SCHEDULES A, B, E, AND BM  
ASHLEY RIVER MILE 1

PLATE 75

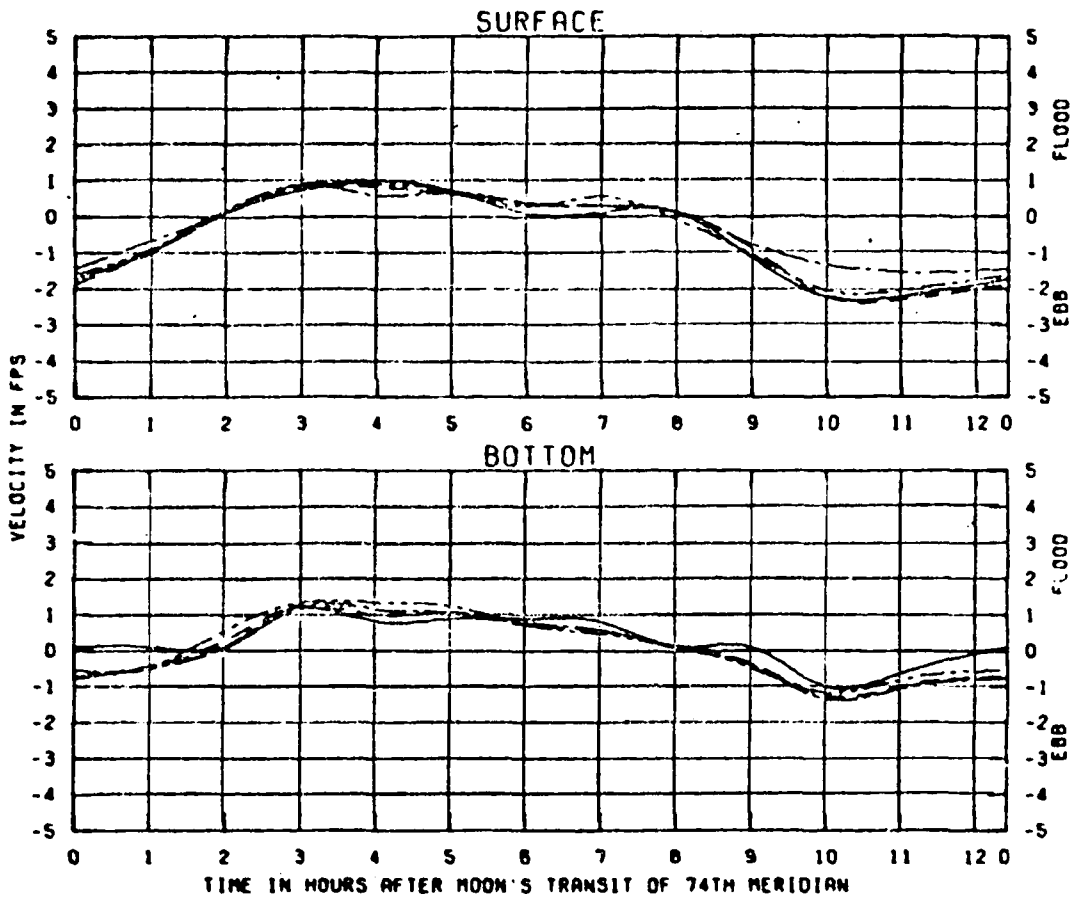

TEST CONDITIONS  
 OCEAN TIDE RANGE 5.4 FT  
 OCEAN SALINITY (TOTAL SALT) 30.0 PPT  
 BUSHY PARK COMBINED WITHDRAWALS 1150 CFS  
 ASHLEY RIVER 261 CFS MANDU RIVER 82 CFS  
 COOPER RIVER - VARIOUS WEEKLY HYDROGRAPHS

LEGEND  
 Sch. A —————  
 Sch. B - - - - -  
 Sch. E - . - . -  
 Sch. BM - . . . -

CHARLESTON HARBOR MODEL  
 BUSHY PARK WATER SUPPLY TESTS

CURRENT VELOCITIES FOR  
 WEEKLY HYDROGRAPH  
 SCHEDULES A, B, E, AND BM  
 ASHLEY RIVER MILE 3

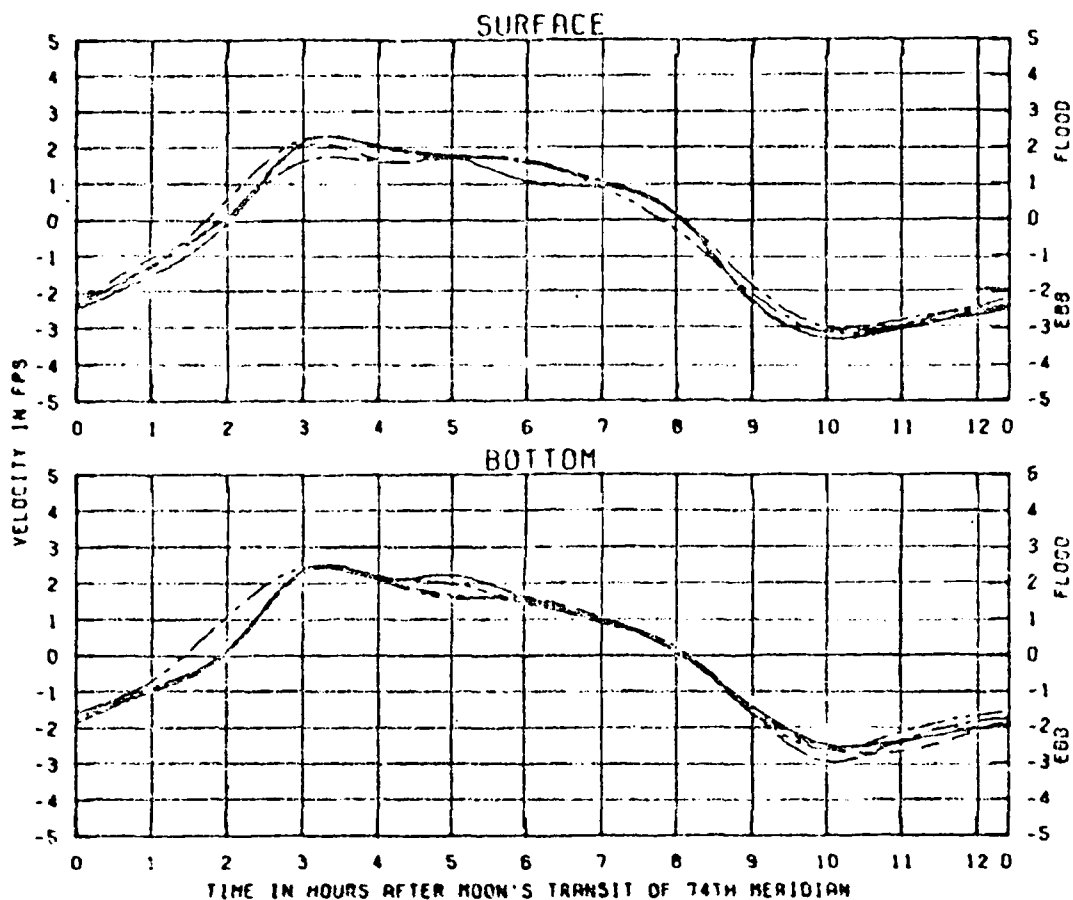

TEST CONDITIONS

OCEAN TIDE RANGE	5.4 FT
OCEAN SALINITY (TOTAL SALT)	30.0 PPT
BUSHY PARK COMBINED WITHDRAWS	1150 CFS
ASHLEY RIVER 261 CFS	KANHO RIVER 82 CFS
COOPER RIVER -	VARIOUS WEEKLY HYDROGRAPHS

LEGEND

Sch. A	—————
Sch. B	- - - - -
Sch. E	.....
Sch. BM	- . . - .

CHARLESTON HARBOR MODEL  
BUSHY PARK WATER SUPPLY TESTS

CURRENT VELOCITIES FOR  
WEEKLY HYDROGRAPH  
SCHEDULES A, B, E, AND BM  
ASHLEY RIVER MILE 5

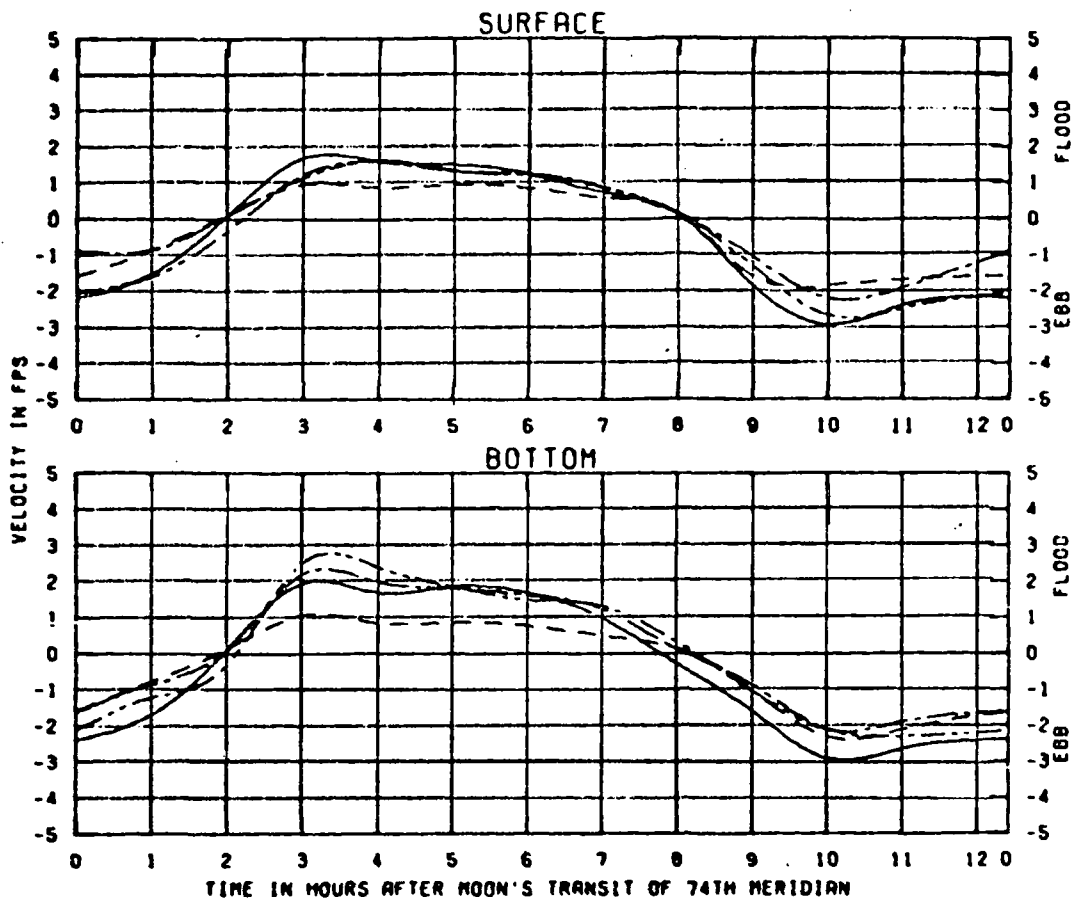

TEST CONDITIONS  
 OCEAN TIDE RANGE 5.4 FT  
 OCEAN SALINITY (TOTAL SALT) 30.0 PPT  
 BUSHY PARK COMBINED WITHDRAWALS 1150 CFS  
 ASHLEY RIVER 261 CFS WANDO RIVER 82 CFS  
 COOPER RIVER - VARIOUS WEEKLY HYDROGRAPHS

LEGEND  
 Sch. A ———  
 Sch. B - - - -  
 Sch. E - . - -  
 Sch. BM - . . -

CHARLESTON HARBOR MODEL  
 BUSHY PARK WATER SUPPLY TESTS

CURRENT VELOCITIES FOR  
 WEEKLY HYDROGRAPH  
 SCHEDULES A, B, E, AND BM  
 ASHLEY RIVER MILE 9

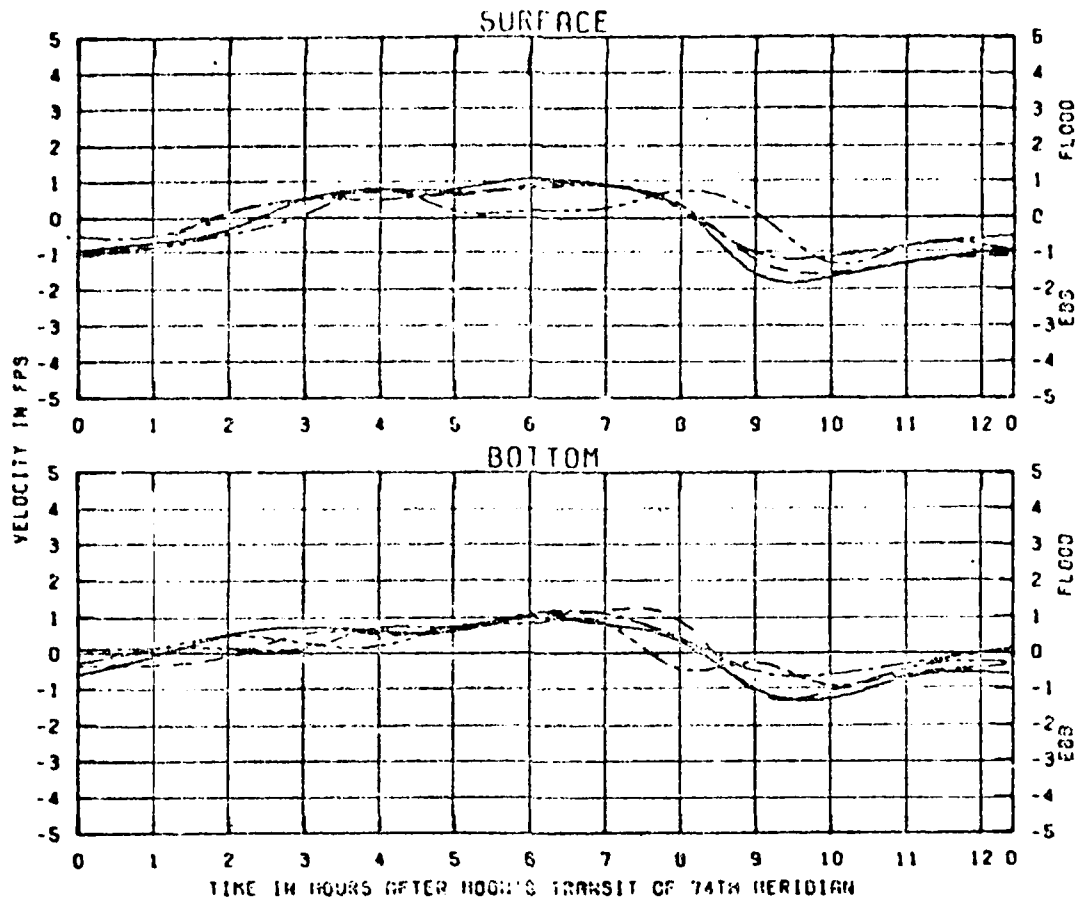

TEST CONDITIONS

OCEAN TIDE RANGE	5.4 FT
OCEAN SALINITY (TOTAL SALT)	30.0 PPT
BUSHY PARK COMBINED WITHDRAWALS	1150 CFS
ASHLEY RIVER 261 CFS	WANDO RIVER 82 CFS
COOPER RIVER -	VARIOUS WEEKLY HYDROGRAPHS

LEGEND

Sch. A	—————
Sch. B	- - - - -
Sch. E	· · · · ·
Sch. BM	- · · - ·

CHARLESTON HARBOR MODEL  
BUSHY PARK WATER SUPPLY TESTS

CURRENT VELOCITIES FOR  
WEEKLY HYDROGRAPH  
SCHEDULES A, B, E, AND BM  
CLOUTER CREEK MILE 1

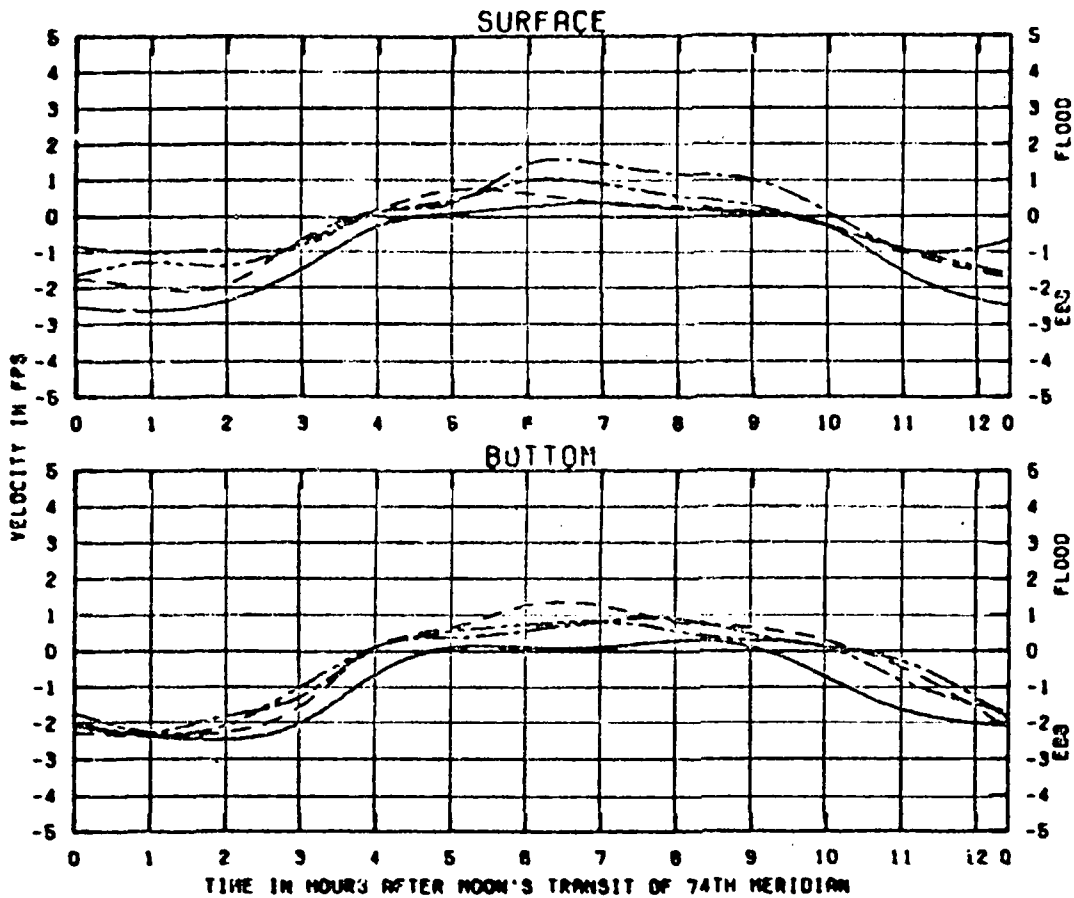

TEST CONDITIONS  
 OCEAN TIDE RANGE 6.4 FT  
 OCEAN SALINITY (TOTAL SALT) 30.0 PPT  
 BUSBY PARK COMBINED WITH RIVERS 1150 CFS  
 ASHLEY RIVER 261 CFS WANDO RIVER 82 CFS  
 COOPER RIVER - VARIOUS WEEKLY HYDROGRAPHS

LEGEND  
 Sch. A ————  
 Sch. B - - - -  
 Sch. C - . - .  
 Sch. D - - - -

CHARLESTON HARBOR MODEL  
 BUSBY PARK WATER SUPPLY TESTS

CURRENT VELOCITIES FOR  
 WEEKLY HYDROGRAPH  
 SCHEDULES A, B, C, AND D  
 COOPER RIVER MILE 30

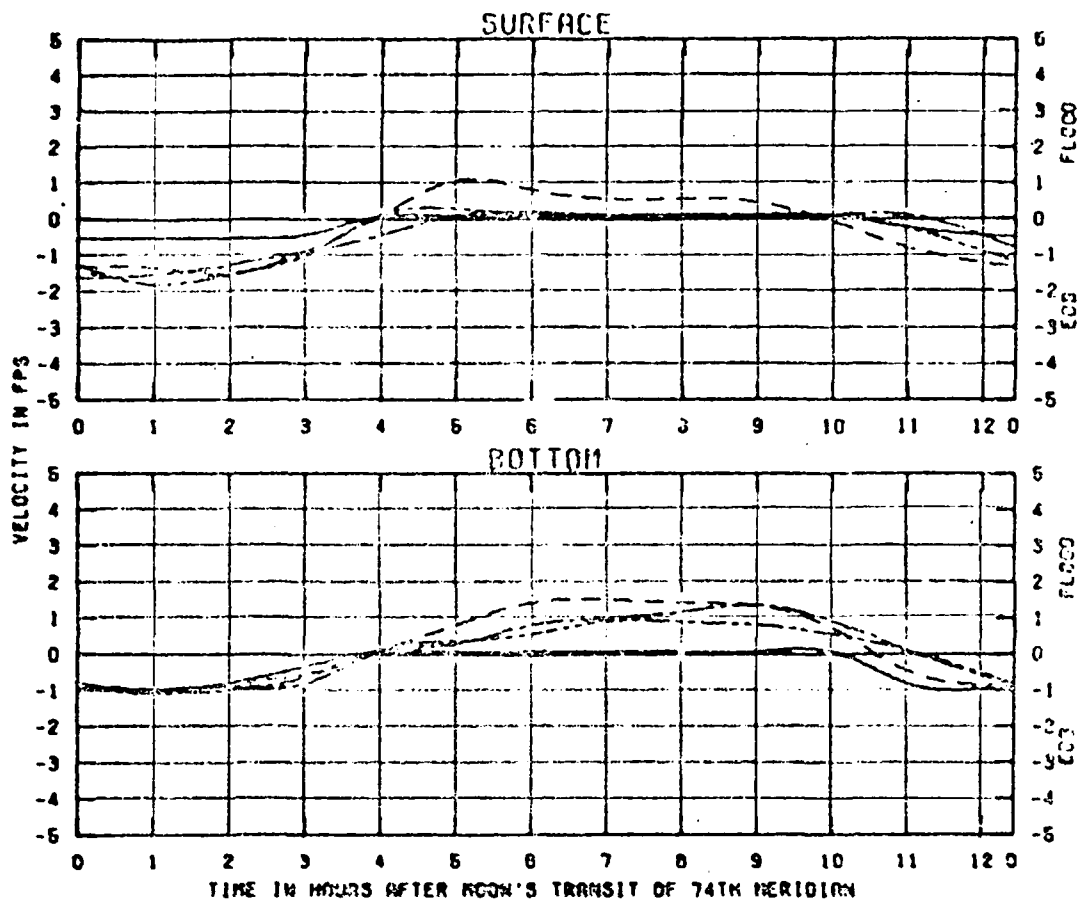

TEST CONDITIONS  
 OCEAN TIDE RANGE 5.4 FT  
 OCEAN SALINITY (TOTAL SOLTS) 30.0 PPT  
 BUSHY PARK COMBINED WITHORINALS 1160 CFS  
 ASHLEY RIVER 261 CFS WANDO RIVER 82 CFS  
 COOPER RIVER - VARIOUS WEEKLY HYDROGRAPHS

LEGEND  
 Sch. A ———  
 Sch. B - - - -  
 Sch. C — . —  
 Sch. D - . . -

CHARLESTON HARBOR MODEL  
 BUSHY PARK WATER SUPPLY TESTS

CURRENT VELOCITIES FOR  
 WEEKLY HYDROGRAPH  
 SCHEDULES A, B, C, AND D  
 COOPER RIVER MILE 34

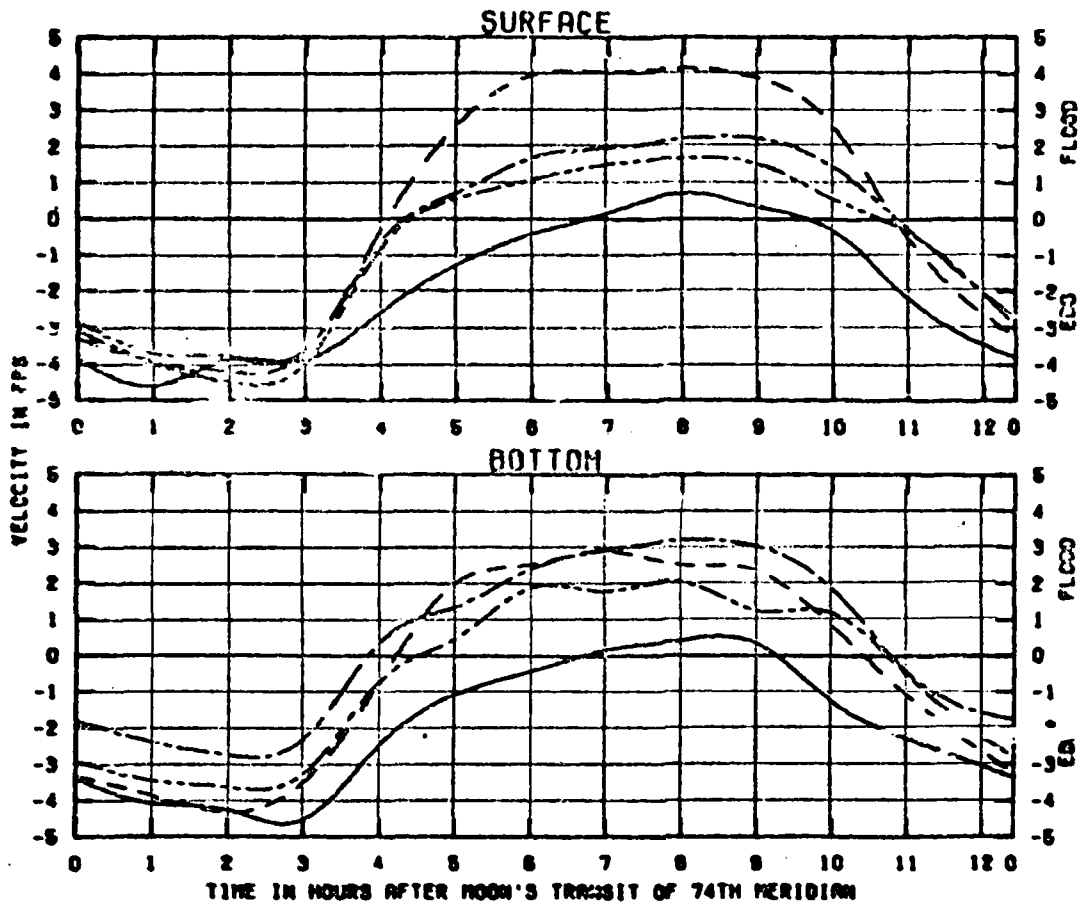

**TEST CONDITIONS**

OCEAN TIDE RANGE	6.4 FT
OCEAN SALINITY (TOTAL SALTY)	30.0 PPT
BUSHY PARK CONFINED WITHDRAWALS	1160 CFS
ADLEY RIVER 281 CFS	WASCO RIVER 62 CFS
COOPER RIVER -	VARIOUS WEEKLY HYDROGRAPHS

**CHARLESTON HARBOR MODEL**  
**BUSHY PARK WATER SUPPLY TEST**

**CURRENT VELOCITIES FOR**  
**WEEKLY HYDROGRAPHS**  
**SCHEDULES A, B, C, AND D**  
**COOPER RIVER MILE 38**

**LEGEND**

Sch. A	—————
Sch. B	- - - - -
Sch. C	- . - . -
Sch. D	- - . - -

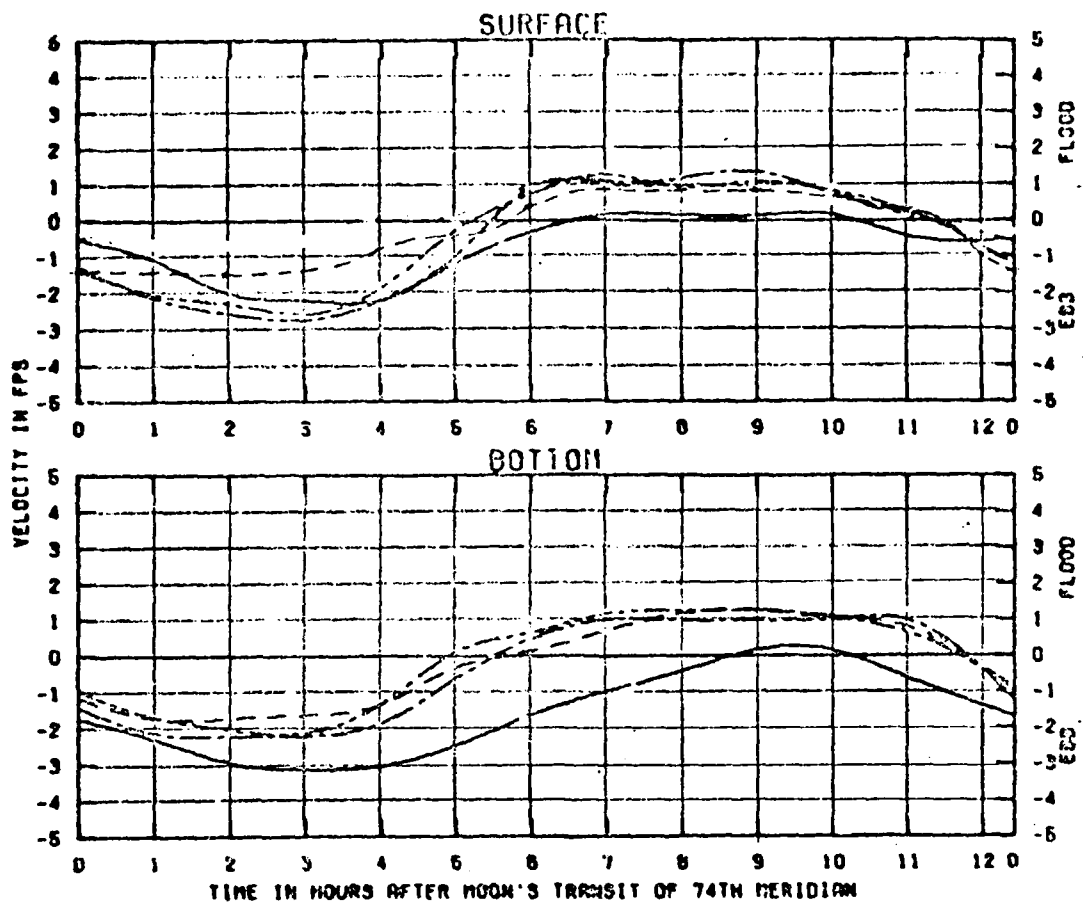

TEST CONDITIONS

OCEAN TIDE RANGE	5.4 FT
OCEAN SALINITY (TOTAL SALT)	30.0 PPT
BUSHY PARK COMBINED WITHOROMALS	1160 CFS
ASHLEY RIVER 261 CFS	WANDO RIVER 82 CFS
COOPER RIVER -	VARIOUS WEEKLY HYDROGRAPHS

CHARLESTON HARBOR MODEL  
BUSHY PARK WATER SUPPLY TESTS

CURRENT VELOCITIES FOR  
WEEKLY HYDROGRAPH  
SCHEDULES A, B, C, AND D  
COOPER RIVER MILE 42

LEGEND

Sch. A	—————
Sch. B	- - - - -
Sch. C	- . - . -
Sch. D	- - - - -

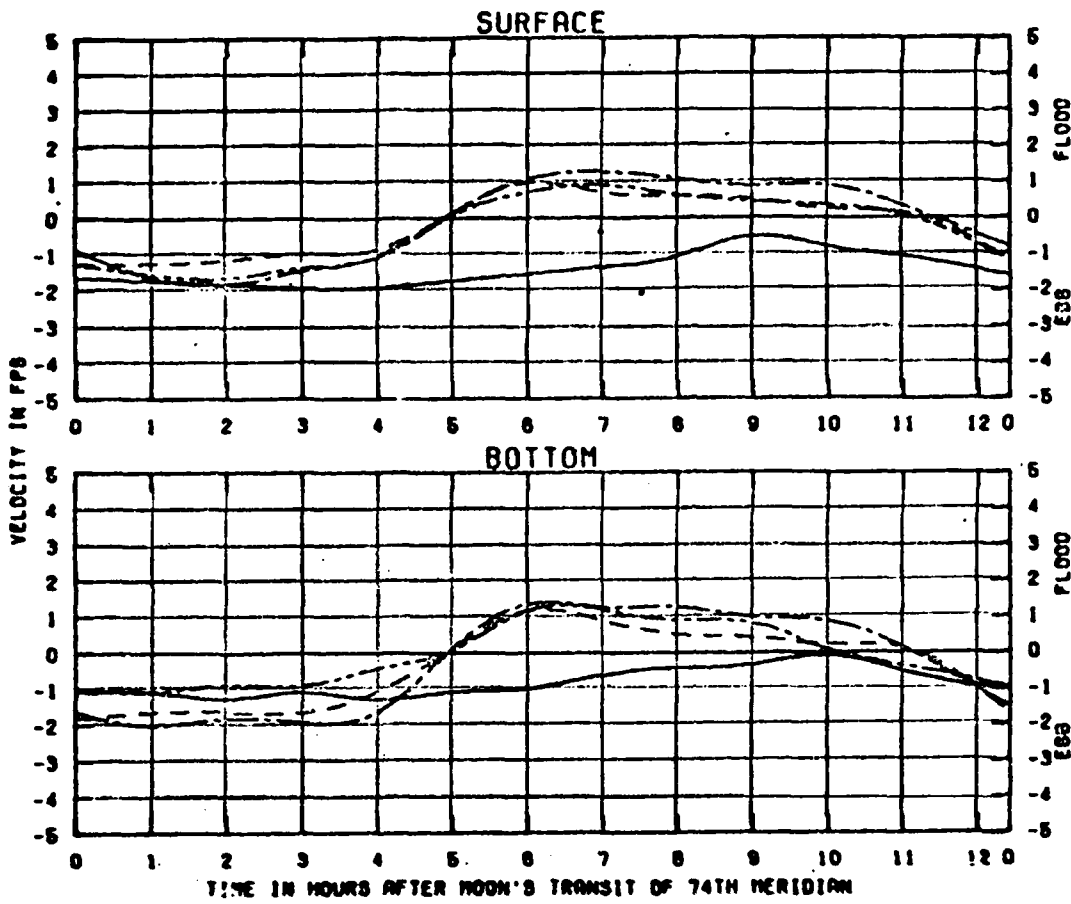

**TEST CONDITIONS**

OCEAN TIDE RANGE	5.4 FT
OCEAN SALINITY (TOTAL SALT)	30.0 PPT
BUSHY PARK COMBINED WITHDRAWALS	1160 CFS
ASHLEY RIVER 261 CFS	WANDO RIVER 82 CFS
COOPER RIVER -	VARIOUS WEEKLY HYDROGRAPHS

CHARLESTON HARBOR MODEL  
BUSHY PARK WATER SUPPLY TESTS

**LEGEND**

Sch. A	—————
Sch. B	- - - - -
Sch. C	- . . . -
Sch. D	- . . . -

CURRENT VELOCITIES FOR  
WEEKLY HYDROGRAPH  
SCHEDULES A, B, C, AND D  
COOPER RIVER MILE 44

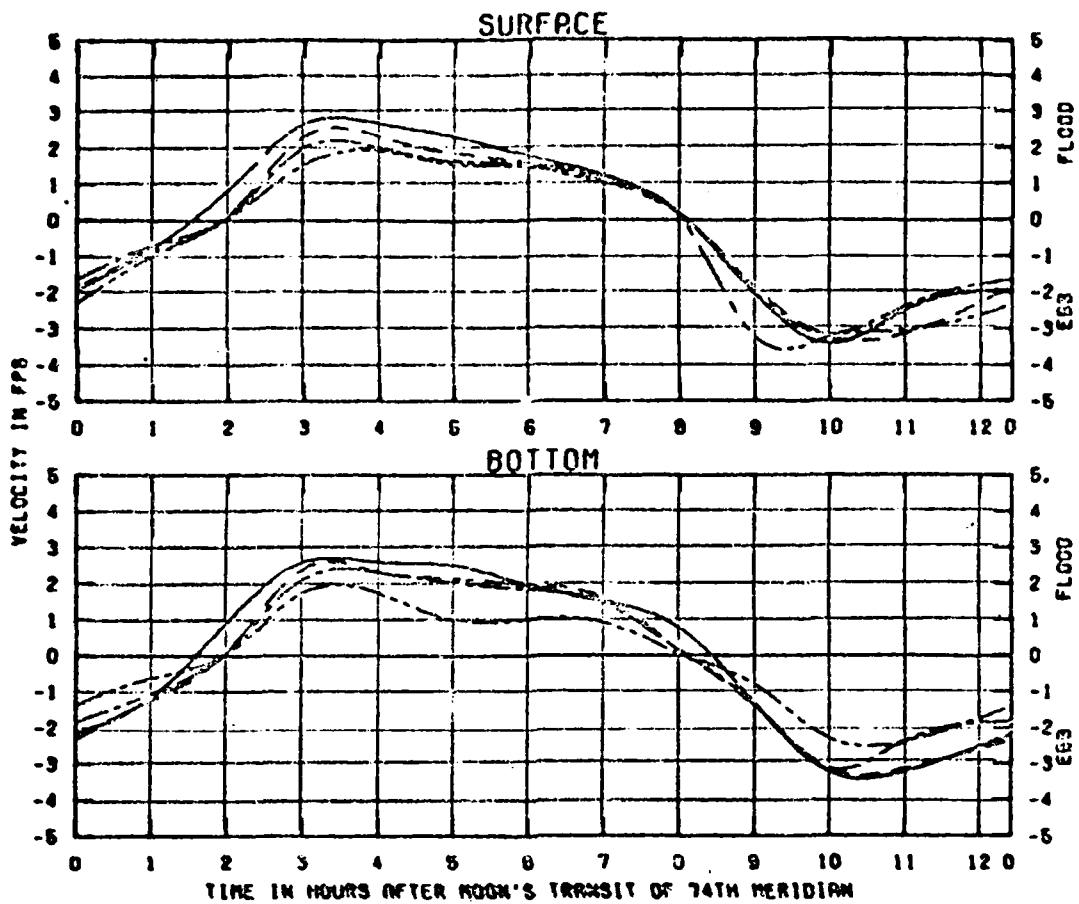

TEST CONDITIONS  
 OCEAN TIDE RANGE 5.4 FT  
 OCEAN SALINITY (TOTAL SALT) 30.0 PPT  
 BUSHY PARK COMBINED WITHDRAWALS 1160 CFS  
 ASHLEY RIVER 261 CFS WANDO RIVER 62 CFS  
 COOPER RIVER - VARIOUS WEEKLY HYDROGRAPHS

CHARLESTON HARBOR MODEL  
 BUSHY PARK WATER SUPPLY TESTS

CURRENT VELOCITIES FOR  
 WEEKLY HYDROGRAPH  
 SCHEDULES A, B, C, AND D  
 WANDO RIVER MILE 3

LEGEND

- Sch. A ————
- Sch. B - - - -
- Sch. C — . —
- Sch. D — . . —

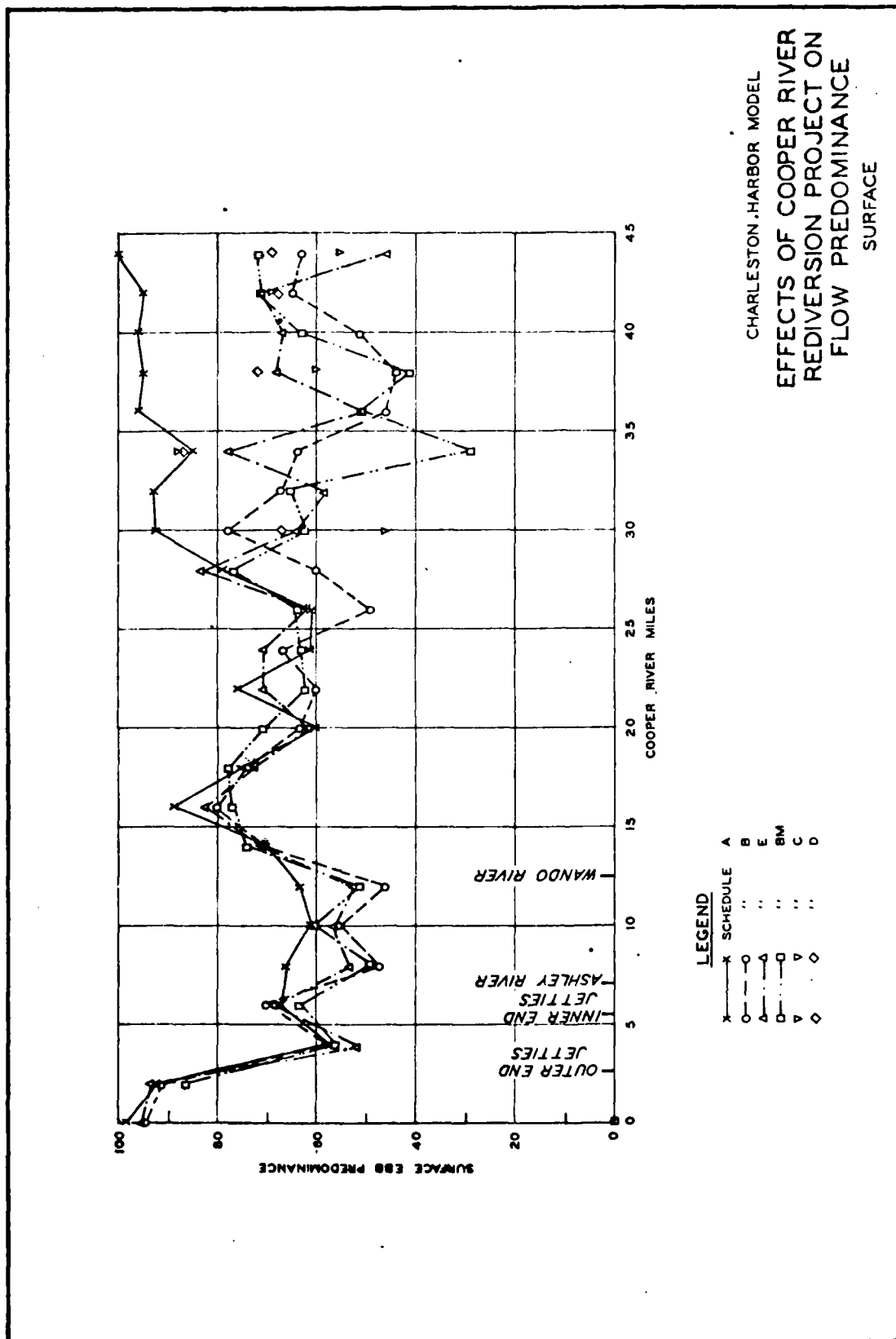

CHARLESTON HARBOR MODEL  
 EFFECTS OF COOPER RIVER  
 REDIVERSION PROJECT ON  
 FLOW PREDOMINANCE  
 BOTTOM

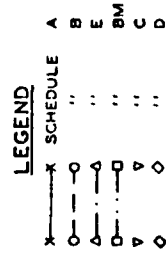
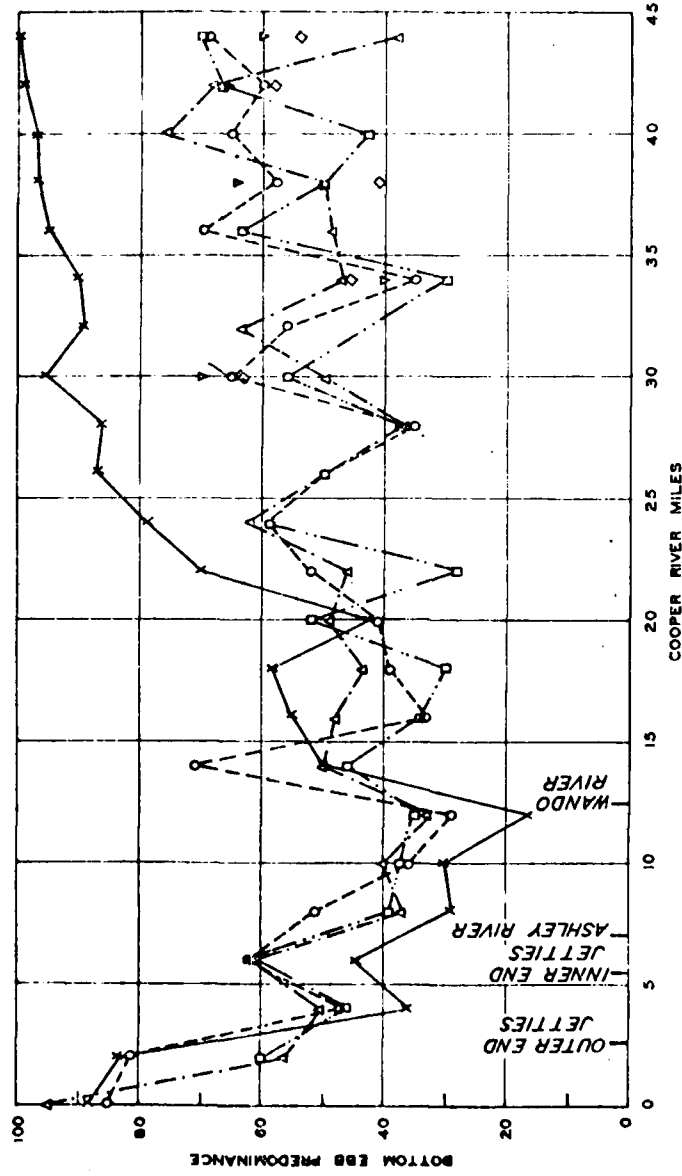

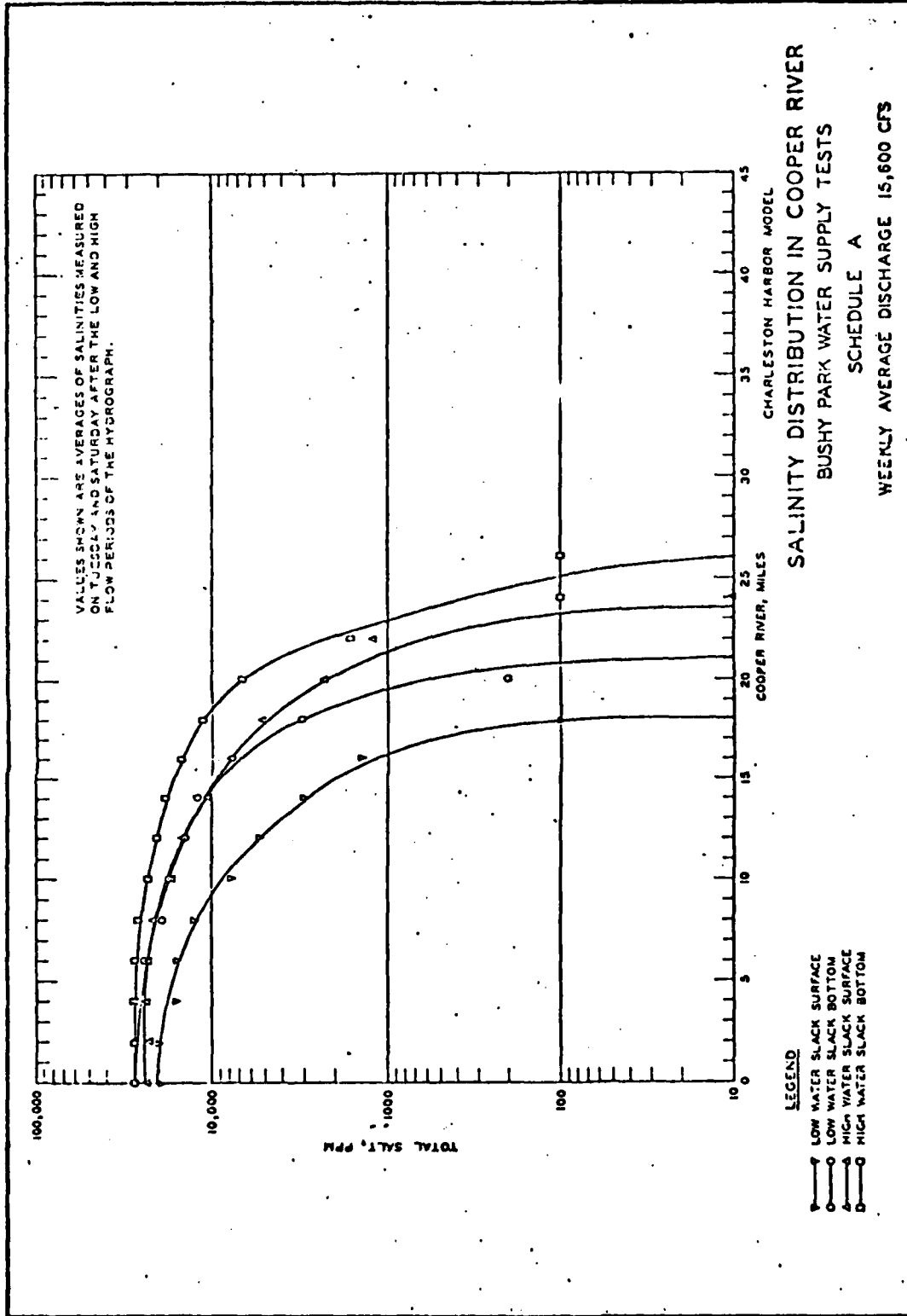

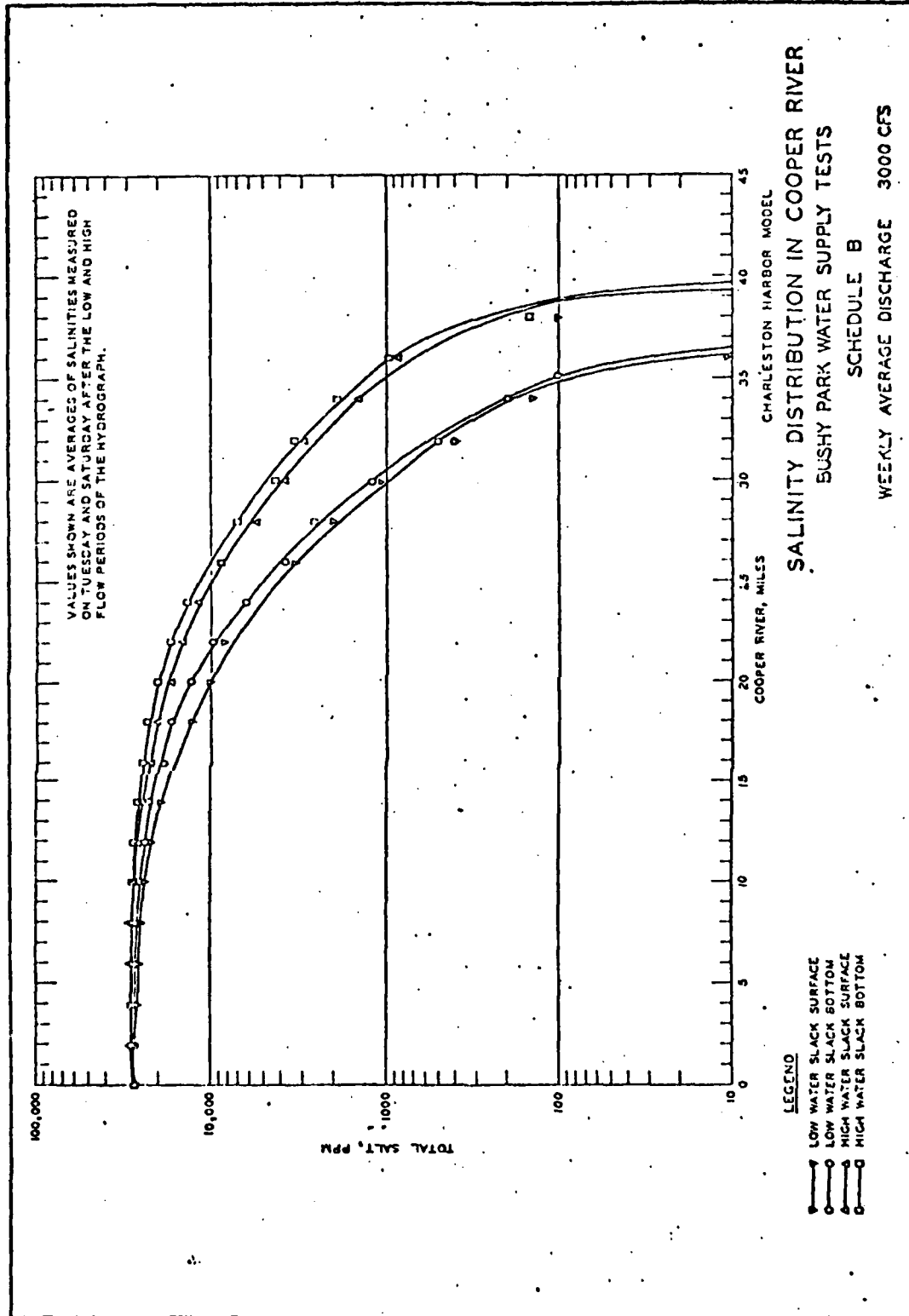

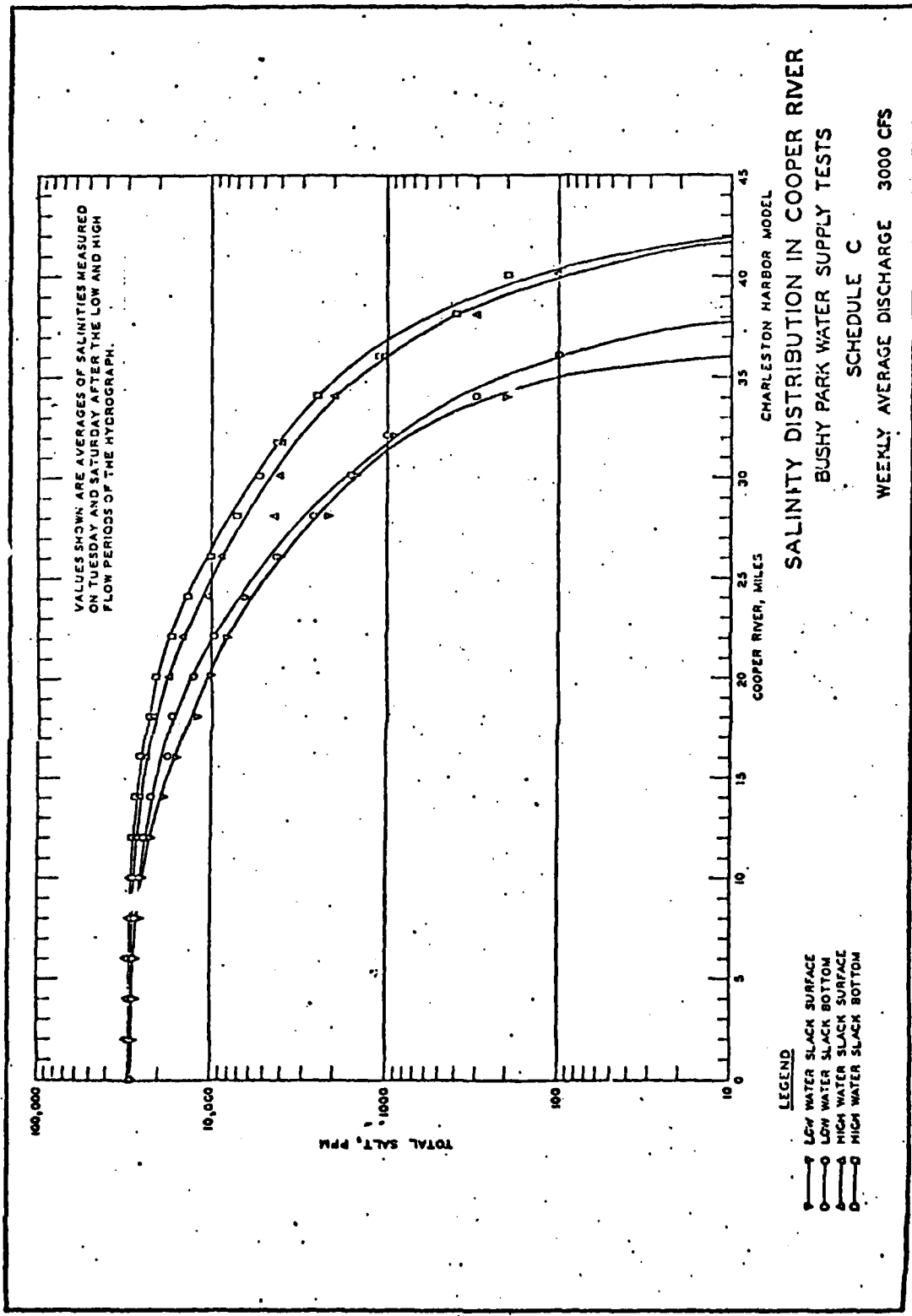
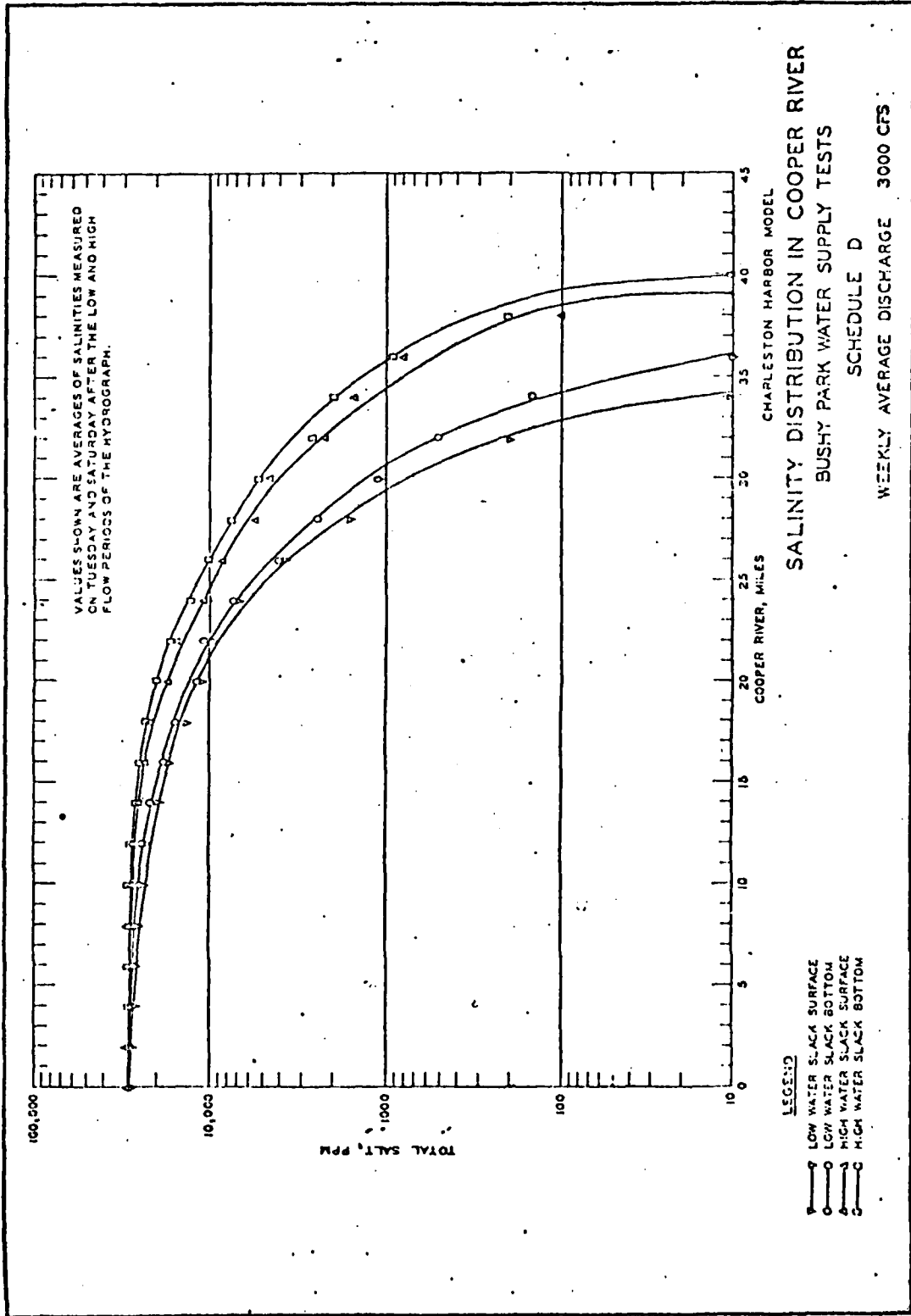
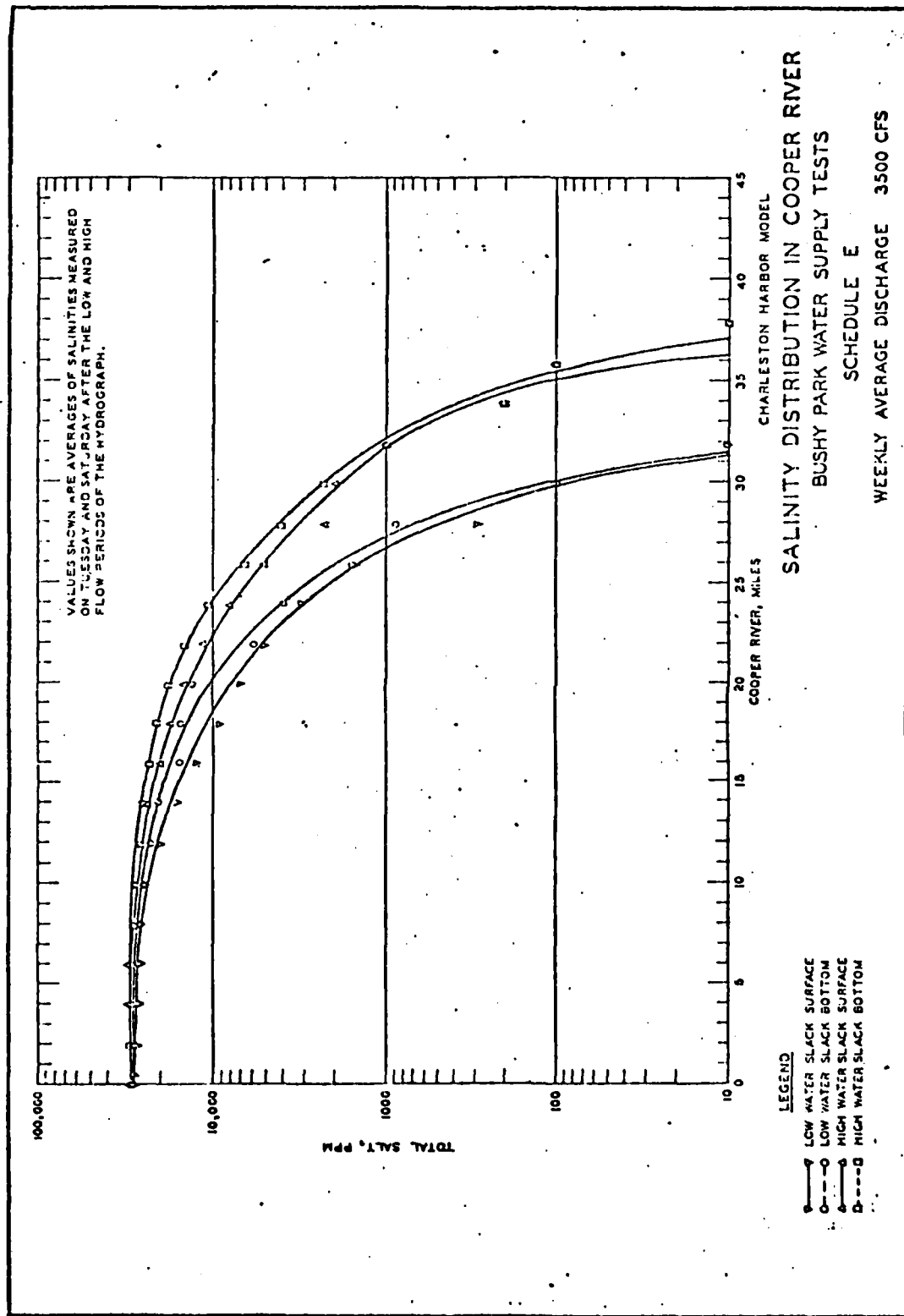
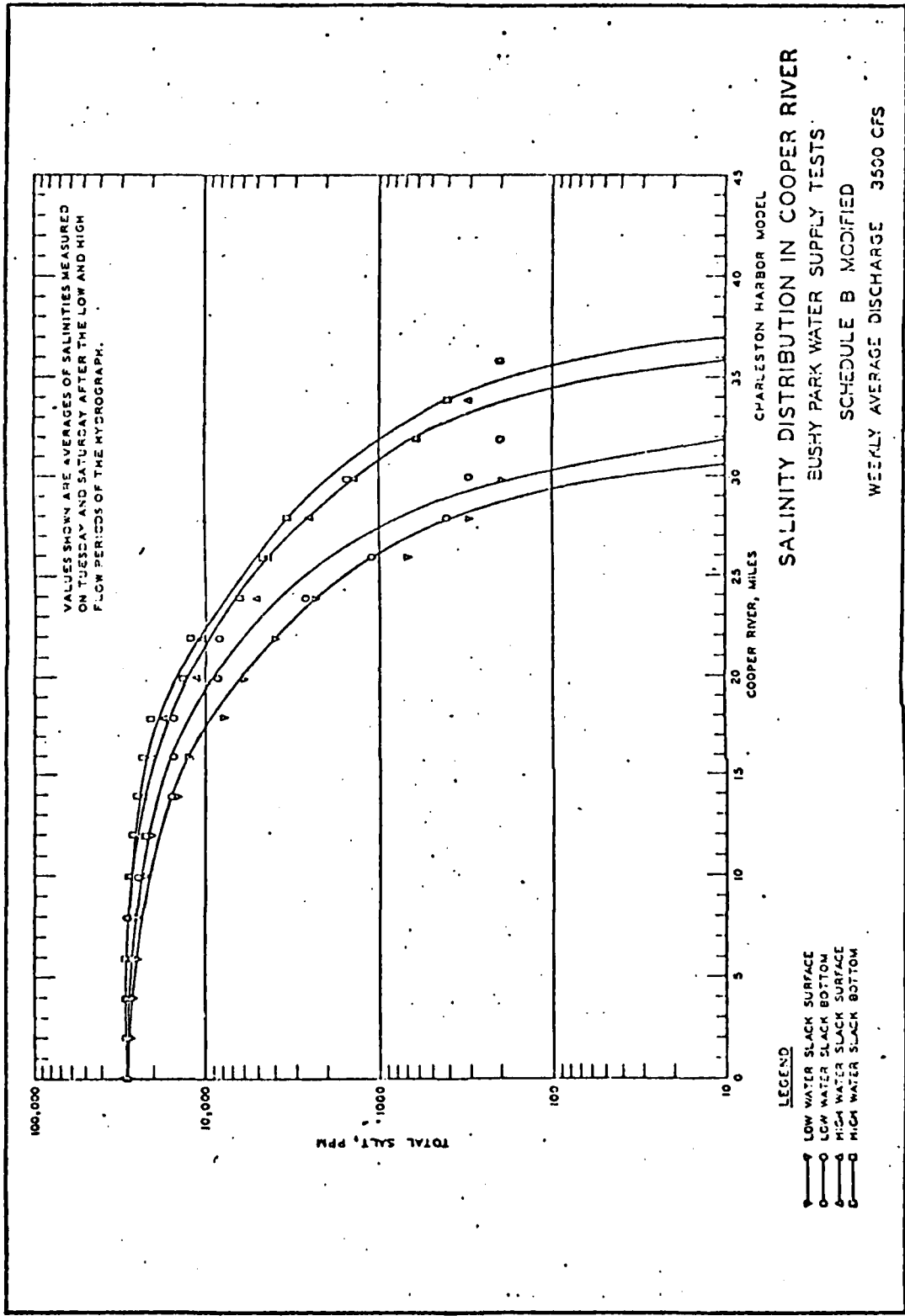

PLATE 90







AD-A150 160

COOPER RIVER REDIVERSION PROJECT LAKE MOULTRIE AND  
SANTEE RIVER SOUTH CAR. (U) CORPS OF ENGINEERS  
CHARLESTON SC CHARLESTON DISTRICT FEB 76

3/3

UNCLASSIFIED

F/G 13/2

NL

END

FILED

DTIC

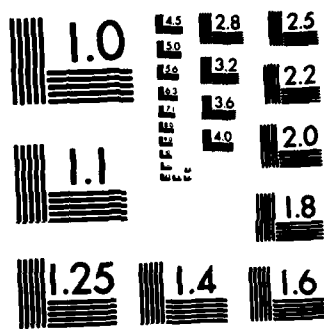

MICROCOPY RESOLUTION TEST CHART  
 NATIONAL BUREAU OF STANDARDS-1963-A

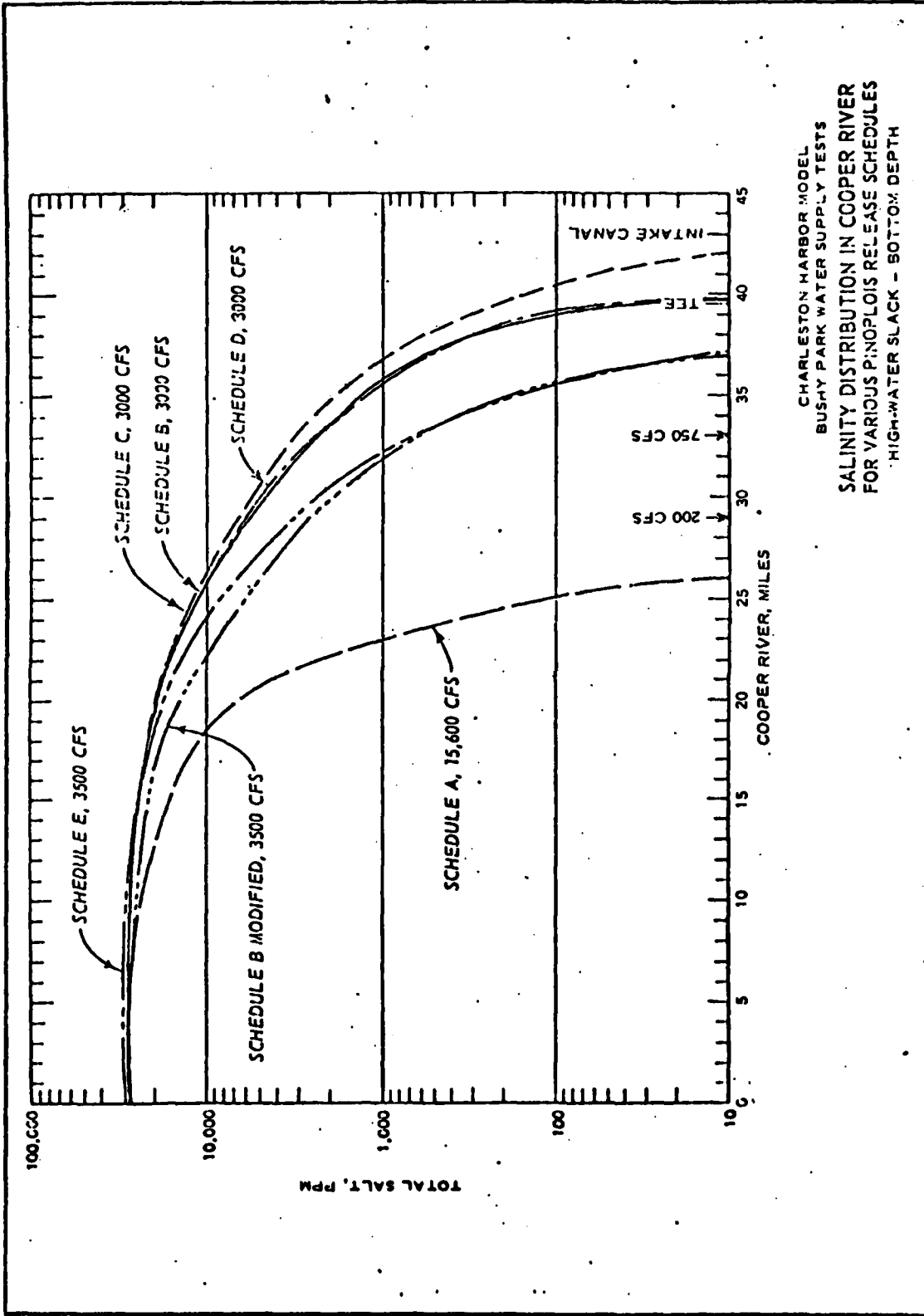

CHARLESTON HARBOR MODEL  
 BUSHY PARK WATER SUPPLY TESTS  
**SALINITY DISTRIBUTION IN COOPER RIVER**  
 FOR VARIOUS PINOPLAIS RELEASE SCHEDULES  
 HIGH-WATER SLACK - BOTTOM DEPTH

In accordance with ER 70-2-3, paragraph 6c(1)(b), dated 15 February 1973, a facsimile catalog card in Library of Congress format is reproduced below.

Benson, Howard A

Cooper River rediversion project, Bushy Park water supply tests; hydraulic model investigation, by Howard A. Benson [and] William H. Bobb. Vicksburg, U. S. Army Engineer Waterways Experiment Station, 1976.

1 v. (various pagings) illus. 27 cm. (U. S. Waterways Experiment Station. Miscellaneous paper H-76-5)

Prepared for U. S. Army Engineer District, Charleston, Charleston, South Carolina.

1. Bushy Park Area, S. C. 2. Charleston Harbor, S. C. 3. Cooper River. 4. Hydraulic models. 5. River diversion. 6. Salt water intrusion. 7. Santee River. 8. Water quality. 9. Water supply. I. Bobb, William H., joint author. II. U. S. Army Engineer District, Charleston. (Series: U. S. Waterways Experiment Station, Vicksburg, Miss. Miscellaneous paper H-76-5)

TA7.W34m no.H-76-5

**END**

**FILMED**

**3-85**

**DTIC**