

MICROCOPY RESOLUTION TEST CHART  
NATIONAL BUREAU OF STANDARDS-1963-A

Unclassified

4

AFOSR-TR- 84-1274

AD-A150 593

REPORT DOCUMENTATION PAGE		READ INSTRUCTIONS BEFORE COMPLETING FORM
1. Report Number	2. Govt Accession No.	3. Recipient's Catalog Number
4. Title (and Subtitle) INITIATION, STABILITY AND LIMITS OF DETONATION FOR ADVANCED STABLE AIRBREATHING AND HYBRIDE PROPULSION ENGINE DESIGN		5. Type of Report & Period Covered Final Scientific Report 15 Mar 82 - 14 Mar 83
Author(s) Professor H.Gg.Wagner and Professor W. Jost		6. Performing Org. Report Number
Performing Organization Name and Address Institute of Physical Chemistry University of Göttingen Tammannstrasse 6 34 Göttingen Federal Republic of Germany		8. Contract or Grant Number AFOSR-82-0145
Controlling Office Name and Address Air Force Office of Scientific Research/NA Bolling AFB, DC 20332		10. Program Element, Project, Task Area & Work Unit Numbers PE 61102 F Proj/Task 2308-A2
Monitoring Agency Name and Address European Office of Aerospace R&D/LNT Box 14 FPO New York 09510		12. Report Date 15 May 1983
		13. Number of Pages 27
		15. <b>UNCLASSIFIED</b>
16. & 17. Distribution Statement Approved for public release; distribution unlimited.		
18. Supplementary Notes		
19. Key Words Flames, Combustion, Detonation, Orifice Plates, Initiation, Stability.		
20. Abstract The influence of orifices on the propagation of flames in tubes has been investigated by measuring flame speeds and pressure on both sides of the orifice and by taking smear camera pictures of the flames passing through the orifice. In addition the jet ignition process was simulated by igniting high speed jets of turbulent unburned gas with electric sparks. Pressure-time pro- files and smear camera pictures give information about the flame speed in gases with very high degrees of turbulence. Other keywords include:		

DTIC FILE COPY

DTIC ELECTED FEB 15 1985

FORM 1473

UNCLASSIFIED

B

Contract Number

AFOSR-82-0145

INITIATION, STABILITY AND LIMITS OF DETONATION FOR  
ADVANCED STABLE AIRBREATHING AND HYBRIDE PROPULSION  
ENGINE DESIGN

H.Gg. Wagner/W. Jost  
Institute of Physical Chemistry  
University  
Göttingen, W. Germany

83 May 15

Final Scientific Report, 82 March 15 - 83 March 14

Approved for public release, distribution unlimited.

Prepared for

USAF Office of Scientific Research  
Building 410, AFB D.C. 20332

and

EUROPEAN OFFICE OF AEROSPACE RESEARCH  
AND DEVELOPMENT  
London, England

## INTRODUCTION

In the past we reported about the influence of single and multiple orifices in the path of a flame on the development of flame speed and pressure behind and ahead of the orifice. Most of these experiments have been performed with stoichiometric mixtures of  $\text{CH}_4$ -air,  $\text{C}_2\text{H}_4$ -air,  $\text{C}_3\text{H}_8$ -air,  $\text{H}_2$ -air,  $\text{COS}$ -air and  $\text{C}_2\text{H}_2$ -air on both sides of the orifices. In addition experiments with oxygen enriched air have been reported. The diameter of the flame tubes ranged from 4 cm up to 50 cm with different combinations up and downstream.

The maximum overpressure obtained depends on the ratio of orifice area to the area of the tube cross section ( $F_o/F_g$ ). Towards smaller orifices there are two values possible. For small tube diameters the maximum overpressure has a maximum around  $F_o/F_g \approx 0.25$  which is shifted towards small  $F_o/F_g$  values and much higher pressure values for tube diameters above a value which is typical for the mixture.

In this report similar experiments are described with mixture-compositions different from stoichiometric and also with systems for which the downstream section is either absent or filled with air.

In jet ignition experiments photographs seem to show that reignition takes place at several spots.

The different flames merge to a single flame. This can give

very high effective flame propagation speeds. In order to find an independent measure of ignition by many flames compared to ignition at a single location, jet ignition experiments should be performed in which ignition does not take place by hot flame gases or by a flame but by an electric spark.

#### EXPERIMENTAL SET UP

The experimental set up is described in detail in previous reports. Here only the main features shall be mentioned.

Flame propagation took place in a driver tube of 200 mm diameter and 100 cm length. At the closed end the gas inlet and a spark plug was mounted. Close to the other end of the tube a Kistler pressure pick up was placed to follow the pressure in this driver section. At the open end of the tube orifice plates with orifices of 2, 3.5, 5, 7 and 10 cm diameter could be fixed. In addition a 20 cm diameter tube with a window along the tube (1 cm length) could be mounted which was open at its downstream end.

For other experiments this brass tube could be replaced by paper tubes which were also 1 m long.

The downstream pressure could be measured at both ends of the downstream tube by a Kistler pressure pick up. For experiments with paper tubes or without a downstream tube, the pressure gauge was mounted at the orifice plate.

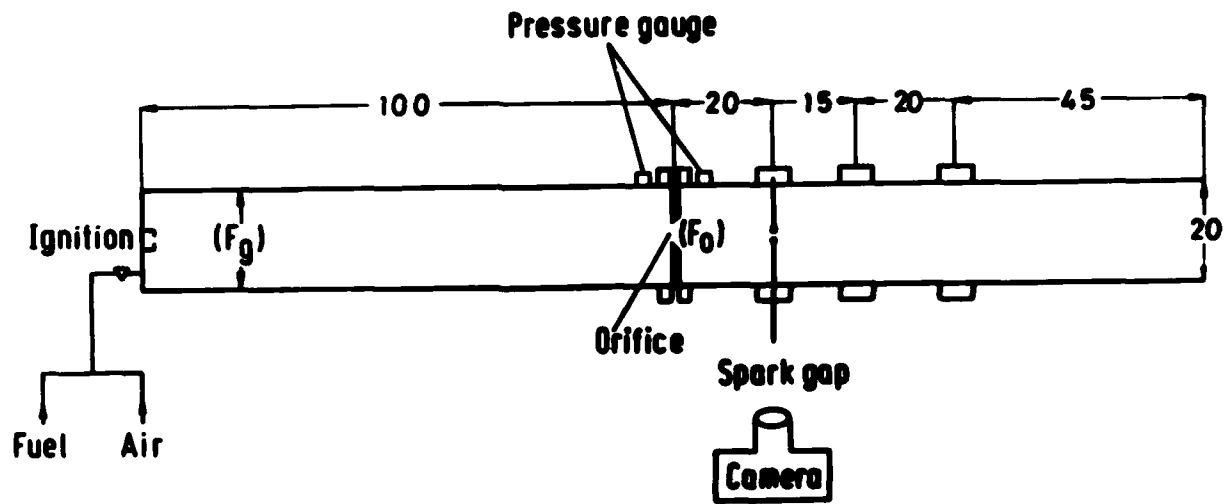

Fig. 1: Sketch of the apparatus used.

For the spark ignition experiments two electrodes could be mounted in the downstream tube at distances of 20, 35 and 55 cm from the orifice plate. The electrodes were made from stainless steel with 0.5 cm diameter. Their ends were ball shaped. The distance of these two electrodes was 0.7 cm. Ignition of the spark was performed by an additional electrode mounted close to one electrode. In air these electrodes could be charged and the spark did not ignite.

When the tube was filled with combustible mixture, it often happened that the spark fired, especially when the mixture was ignited in the driver section with the spark plug. In order to avoid this irregular firing of the spark, which could become dangerous, the two electrodes were covered with plastic tubing such that they could not see the spark in the driver section.

The electric circuit is shown in Fig. 2. The connection between electrodes and power supply was a coaxial cable with a capacity of 30 pF per meter, 0.5 m long.

The voltage of the circuit was usually about 8000 Volt. In order to vary the spark energy, the condensers could be varied such that the length of the connecting wires remained approximately the same.

A delay system allowed to fire the spark a certain time after the flame in the driver section was ignited. This time was chosen such that the pressure in the driver section had reached or was close to its maximum value and the flame was still sufficiently far away from the orifice so that ignition and flame in the downstream section could develop to a sufficient extent.

The energy values  $E$  reported are those calculated from  $E = 1/2 CU^2$  where  $C$  is the capacity and  $U$  the voltage at the condenser at time zero. The inductivity of the system was about 1  $\mu$ H. This  $E$  value does not give the energy which is available for ignition because it includes, besides the heat and work produced, special electronic excitation and ionisation processes which may not help combustion. The rest charge of the condenser is also neglected as well as the tail of the discharge. The time of the first current peak is about 60 ns (at half maximum current). Rise time to maximum is about 50 ns.

### Power Supply

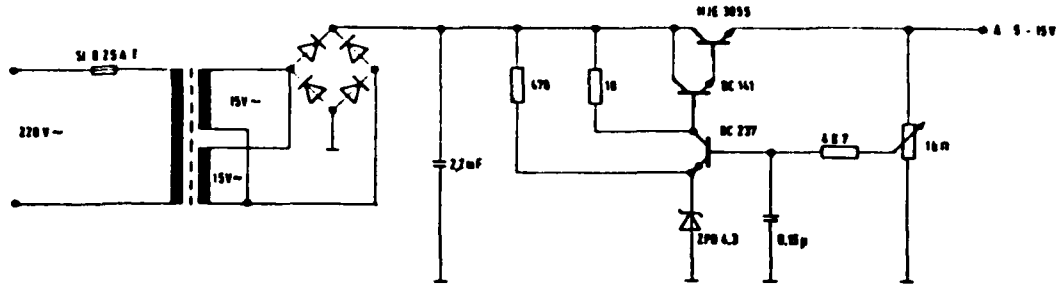

### High Voltage

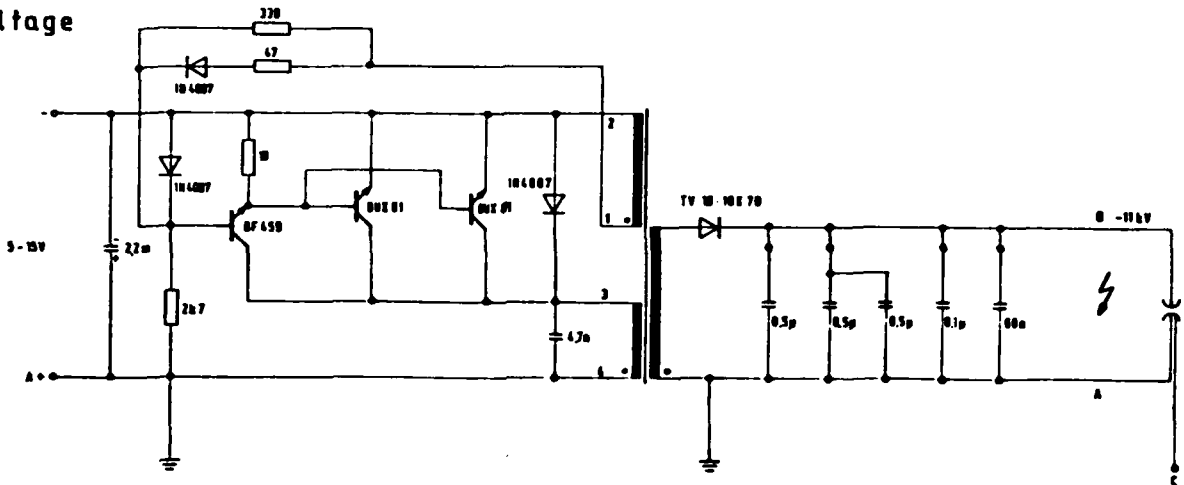
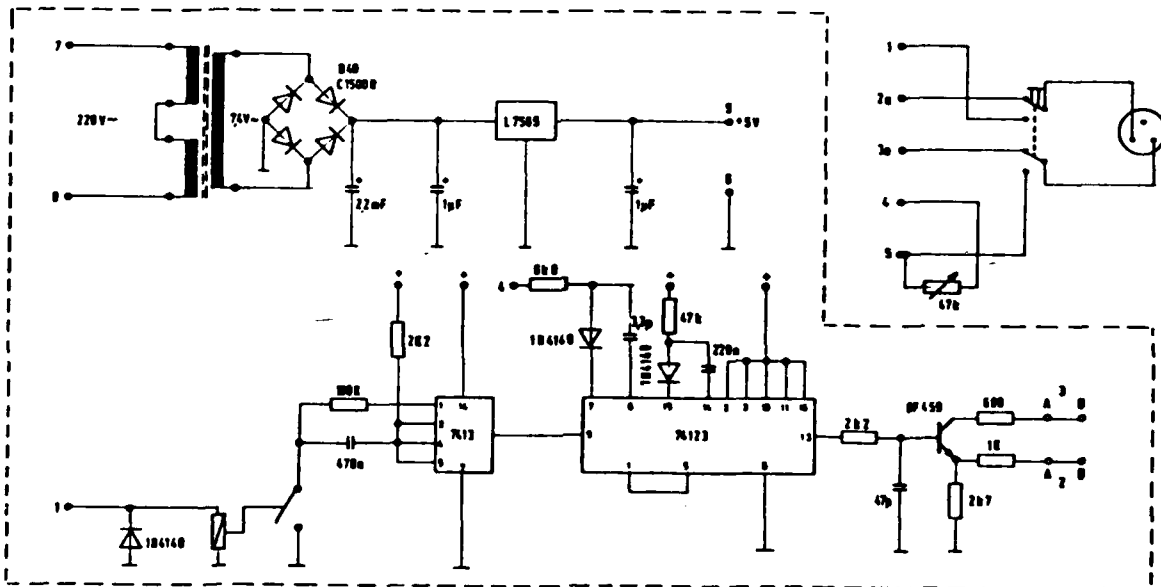
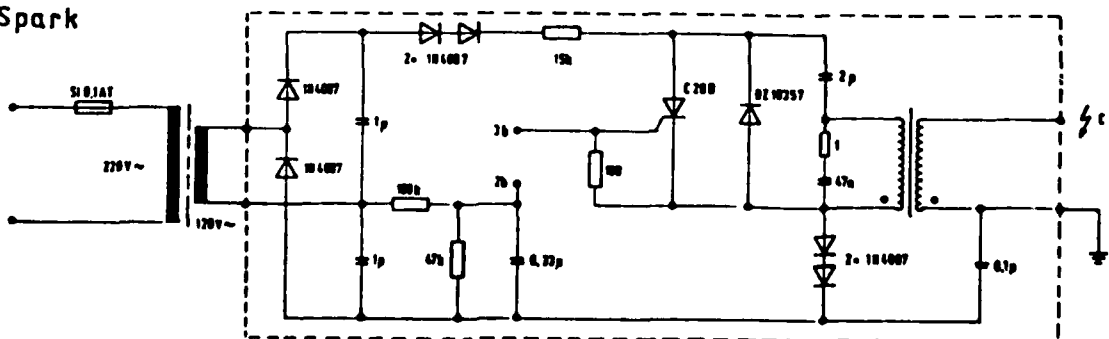

Fig. 2a: Power supply for spark ignition.

### Ignition Delay



### Auxiliary Spark



One may expect that the energy useful for ignition is only a fraction of the value  $E$ . It seems, however, not unreasonable to assume that it is proportional to  $E$  in the range covered here.

### EXPERIMENTAL RESULTS

#### The Influence of $C_2H_4$ Concentration in Air on Jet Ignition

The general trend of the influence of mixture composition on jet ignition is shown in a previous report for a 4 cm diameter tube. Here, results are represented which give more details of the process.

In order to be able to calculate the jet speed it is necessary to know the maximum pressure  $\Delta P_{\max}$  in the driver section for different mixture compositions. This is shown in Fig. 3 for  $C_2H_4$ -air mixtures, plotted as a function of the actual ethylene concentration divided by the ethylene concentration in stoichiometric mixtures. The orifice used had 100 mm diameter.

The  $\Delta P$  curve in Fig. 3 shows a form which is similar to that of the curve for the laminar flame velocity plotted with the same abscissa. Towards rich mixtures the  $\Delta P_{\max}$

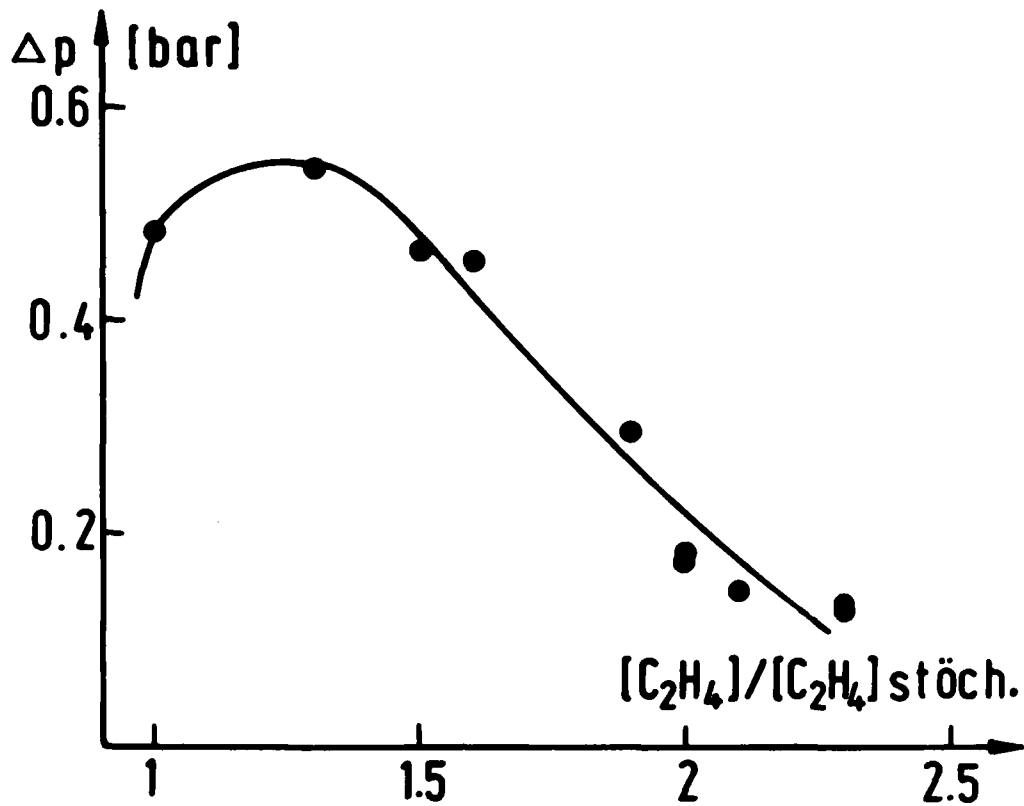

Fig. 3: Maximum pressure  $P_{Max}$  in driver section as a function of fuel concentration.

values decline and a maximum in the curve seems to be close to the concentration for maximum flame speed. For other orifices, the curves look similar, but have different absolute values of the pressures.

Downstream of the orifice plate the overpressures were below 0.1 bar.

A smear camera photograph of a process with 100 mm diameter orifice and solid tubes on both sides of the orifice is shown in Fig. 4. The orifice is on the left side of the figure, the distance between the two dark vertical lines



Fig. 4: Smear camera picture of jet ignition.

is 10 cm. This photograph shows that the transmission of the flame through the orifice (10 cm diameter!) is not a smooth process. The lines on top of the figure correspond to flow lines of the gas. Towards longer times these lines seem to bend backwards, before they turn again into the direction of the original jet flow.

#### Influence of the Conditions Downstream of the Orifice

Three cases shall be compared for a mixture with  $C_2H_4/C_2H_4$  stoich = 1.3, a slightly rich mixture, and an orifice with 50 mm diameter.

- a) The solid tubes up and downstream of the orifice are filled with mixture.
- b) Only the driver section is filled with mixture, the downstream section with air.
- c) The driver section is filled with mixture, the downstream section is removed, the jet flows into open air.

These three events can be compared in Fig. 5a, b, c for which the photographic conditions (film sensitivity, exposure time, etc.) are equal. The orifice plate is on the left side of each photograph. Each figure shows a system of "stripes" coming out of the orifice and Fig. 5a and 5b are showing only little differences. The shape of the downstream pressure signals are also similar. The maximum overpressure, however, is ca. 6 bar in 5a and about 4 bar in 5b. The Fig. 5c looks different: here the entrainment of



a

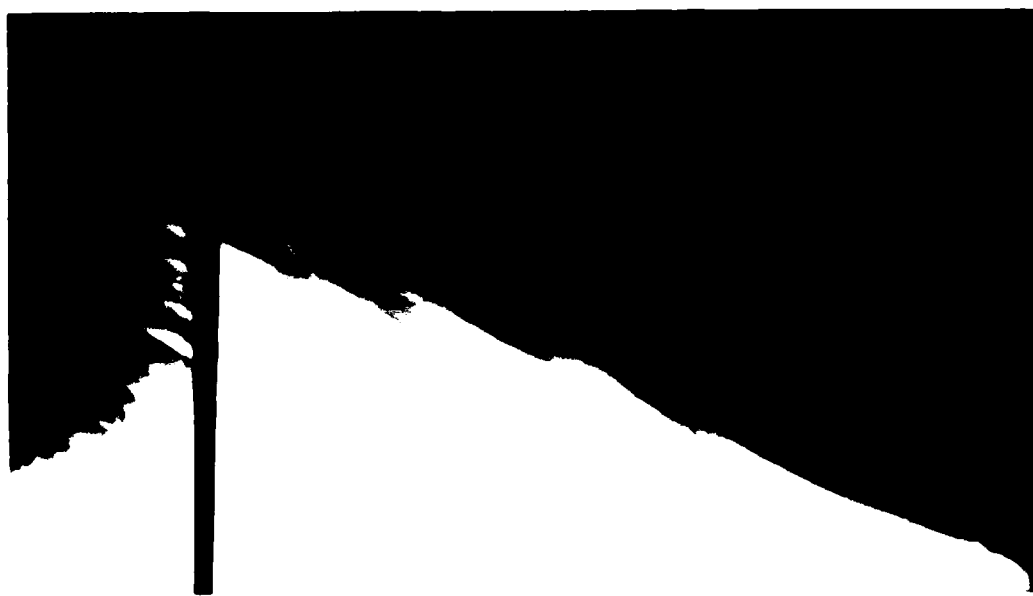

b



c

Fig. 5:  
Jet ignition  
for different  
conditions  
downstream  
of the orifice  
(see text).

air is apparently sufficiently strong to nearly extinguish the flame, to dilute mixture so that combustion proceeds with relatively low intensity and one can easily recognize the pronounced structure in the burned gas. In Fig. 5b there is also entrainment of air, the conditions are, however, such that the vortex around the jet recirculates a gas with increasing fuel concentration (and not fresh air!)

If for the conditions of case 5b the solid tube is replaced by a tube made from a thin plastic foil, the results on the photograph are rather similar to Fig. 5b, the pressure downstream of the orifice remains, however, much lower than in Fig. 5b.

#### Jet Flowing into Open Air

For a 50 mm diameter orifice the combustion in case 5c was rather low intensity due to the unhindered entrainment of air. One can expect that for larger orifices and for richer mixtures the influence of entrainment might be different.

A sequence of figures 6a-d shows for a 100 mm diameter orifice the influence of the mixture strength:  $C_2H_4 / (C_2H_4)_{stoich} = \alpha$   
6a:  $\alpha = 1$ ; 6b:  $\alpha = 1.3$ ; 6c:  $\alpha = 1.6$ ; 6d:  $\alpha = 2.0$ ; 6e:  $\alpha = 2.3$ .

For the stoichiometric mixture entrainment weakens the combustion intensity and the flame propagation speed taken from the photograph is around 400 m/s near the orifice. It has

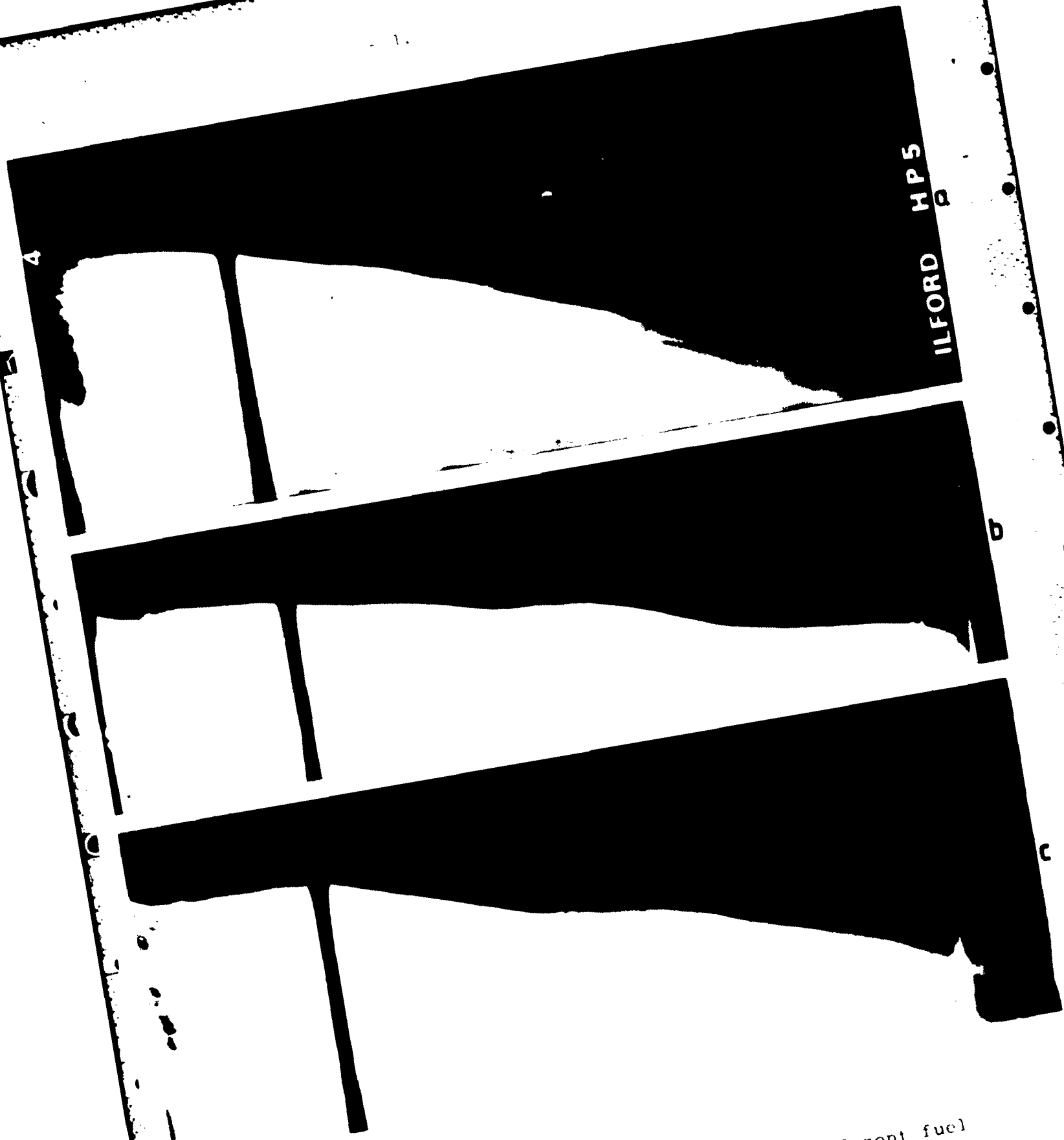

Fig. 6a-c: Jet ignition in open air for different fuel concentrations in the driver section; a:  $\alpha = 1$ ; b:  $\alpha = 1.3$ ; c:  $\alpha = 1.6$ .



to be kept in mind that here the jet speed is rather high due to the high driving pressure (see Fig. 3). For  $\alpha = 1.3$  the flame speed increases strongly to about 600 m/s and for the  $\alpha = 1.6$  mixture it reaches about 800 m/s. (Here the driver pressure is already lower than for  $\alpha = 1.3$ .) For richer mixtures the flame speed near the orifice decreases as can be seen in 6d and 6e.

This decrease in combustion intensity is mainly due to the decrease in driving pressure (Fig. 3).

An increase of the orifice diameter for a given mixture which is linked to a reduction of the driving pressure and the jet velocity is also linked to a decrease of the downstream flame velocity.

#### Ignition of the Jet by Electric Spark

When a hot gas jet passes into unburned mixture burned and unburned gas is mixed (turbulent with a certain degree of unmixedness), the temperature of the mixture increases and the concentration of combustible gas goes down. The chemical energy density available for the production of work decreases, reaction rates, however, are favourably influenced, especially ignition processes.

For a spark, which ignites a jet, the energy deposition is concentrated to a relatively small volume. During the spark time the jet "blows away" the spark. If

the jet velocity is about 200 m/s the gas between the spark gaps passes the gap in about  $2 \cdot 10^{-5}$  s. This is longer than the spark duration but at most an order of magnitude. The spark will be influenced by the flow. On the other hand, this spark time should be short enough to concentrate the available spark energy within a defined volume which can have energy losses by turbulent mixing dissipation.

There is a certain influence of the spark gap on the jet flow because the spark gaps act as an additional obstacle in that high velocity flow. This might be the reason for some of the observations made here.

#### Spark Ignition in Jets

The velocity of the jet of unburned gas passing through the orifice is determined by the overpressure in the driver section. After some time of flame travel in the driver section the pressure reaches a nearly stationary value which lasts about 10 ms. This should be long enough to establish a nearly stationary situation in the jet. These overpressures in the driver section are a function of the ratio of orifice area ( $F_o$ ) to tube area ( $F_g$ ) which is shown for stoichiometric  $C_2H_4$ -air mixtures in Fig. 7.

Measurements have been performed for distances of the spark gap from the orifices of 20, 35 and 55 cm.

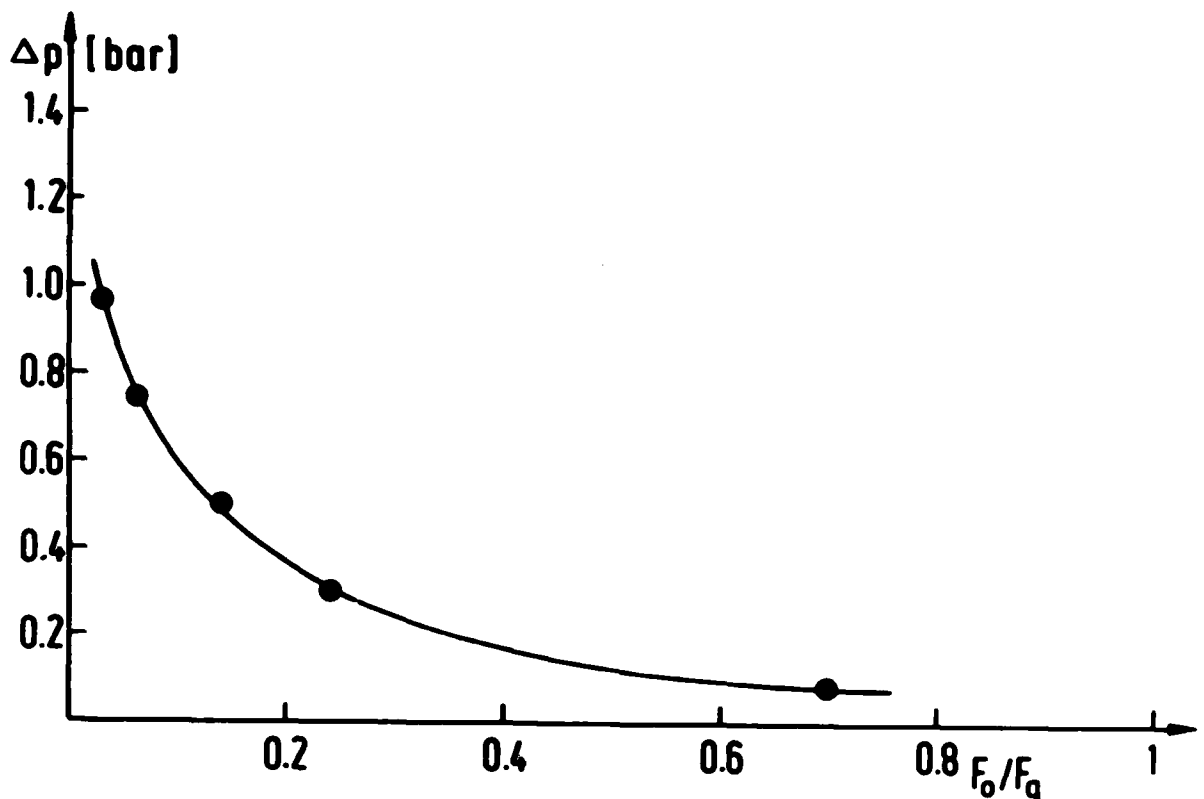

Fig. 7: Overpressure  $\Delta P$  as a function of  $F_o/F_g$  for  $C_2H_4$  - air stoichiometric.

Results for an Orifice with 20 mm Diameter

The data obtained for an orifice with 20 mm diameter are shown in Fig. 8. The energy  $E$  (for definition see: Experimental Set up) necessary to ignite the jet decreases with increasing distance of the spark from the orifice. With lower values of  $E$  no ignition could be observed under the conditions specified. The maximum overpressures obtained in the section downstream of the orifice are about the same as for flame jet ignition. An increase of the spark energy  $E$  has little influence.

For the 20 mm diameter orifice ( $F_o/F_g \approx 0.01$ ) the driving pressure is rather high (see Fig. 7) (close to the de Laval

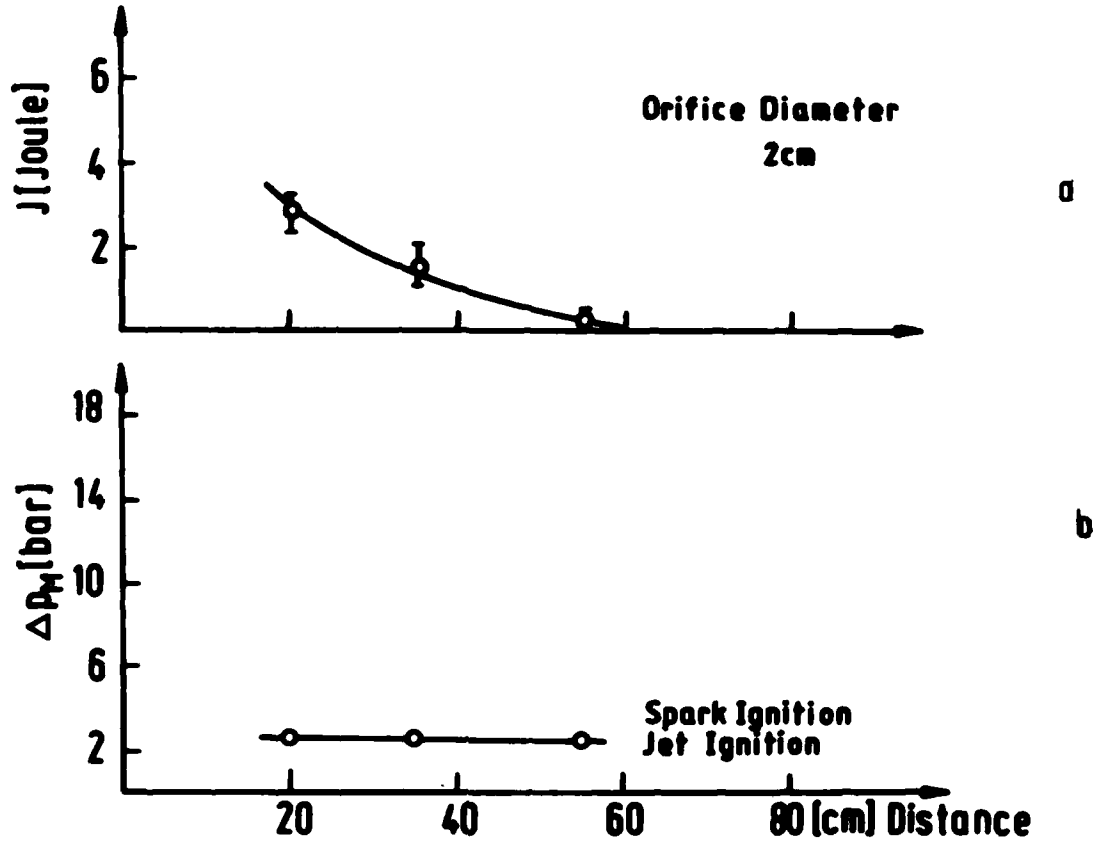

Fig. 8: Energies  $E$  necessary to ignite jet (8a) at distances given on the abscisse and maximum overpressures (8b) measured downstream of orifice. Orifice diameter 2 cm.

pressure) and the jet speed is high. On the other hand the spark gaps are rather far apart from the orifice in terms of the orifice diameter  $d$ . With an average length of the kernel of the jet of 5 to 6 orifice diameters, the first gap position is about two kernel length away and the jet flow is in a region of full turbulence but at already strongly reduced speed such that speed and turbulent mean fluctuation velocities are rather low. On the other hand the jet itself is nearly a completely free jet and the flow in the surrounding of the jet is fairly quiet with very low turbulence level. Therefore, flame propagation outside of the jet should be slow and the total overpressure achieved should also be

Results for Orifice with 35 mm Diameter

For this orifice the driving pressure is lower than for the 20 mm orifice. The energy  $E$  required for the ignition of the jet shows the same dependence on the distance of the gap from the orifice, but it is higher. This is shown in Fig. 9. The pronounced difference between these experiments and those performed with a 20 mm orifice is the maximum overpressure achieved. Fig. 9b shows the overpressures which can be measured if ignition is caused by a flame passing through the orifice (lower curve, independent of spark gap distance) and by a spark of the energy shown in Fig. 9a. These values are definitely higher and close to the detonation

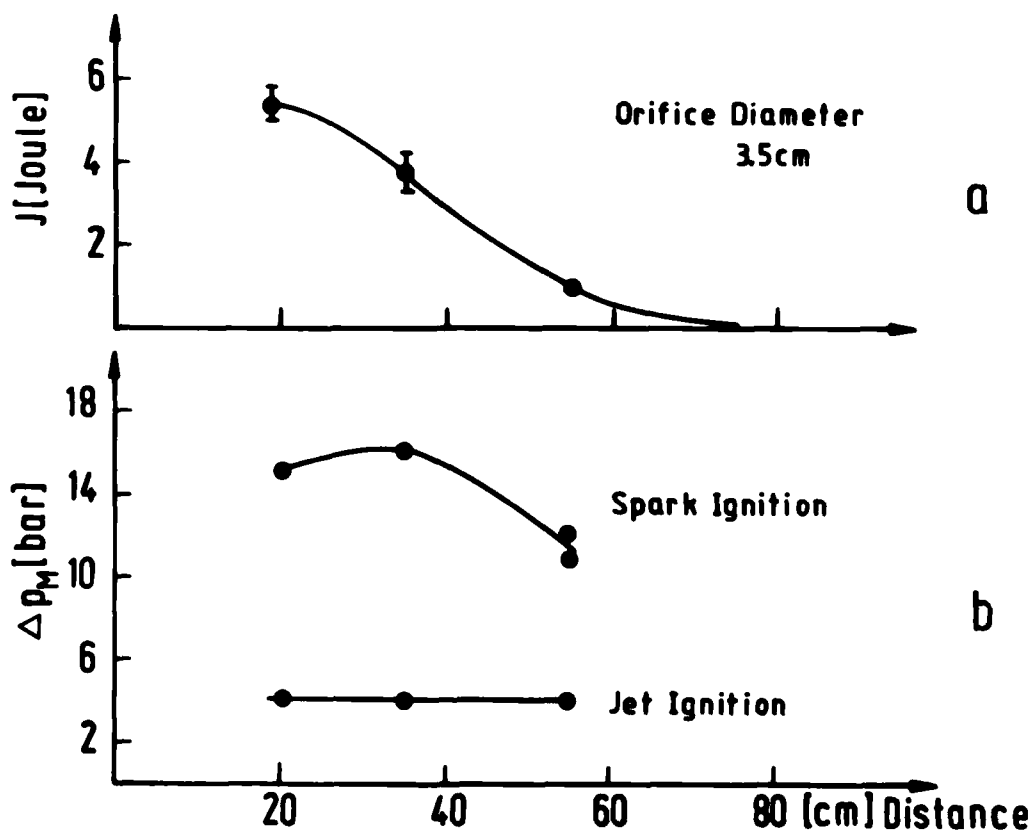

Fig.9: Energies  $E$  necessary to ignite jet (9a) at distances given on the abscisse and maximum overpressures (9b) measured downstream of orifice. Orifice diameter 3.5cm

pressures. There is not much difference whether the spark gap is located 20 or 55 cm away from the orifice.

In this case the "quiet kernel" of the jet reaches to about 20 cm from the orifice so that the first position of the jet (20 cm) should be in the fully turbulent domain.

#### Results for a 50 mm Diameter Orifice

For the 50 mm diameter orifice the minimum energy  $E$  required to ignite the jet shows a different dependence on the gap distance. For the small gap distance the  $E$  value goes down again and the curve exhibits a maximum. In this case the spark position at 20 cm is definitely within the kernel of the jet. Turbulence will be generated in the flow around the spark gaps but that should start only a short distance downstream so that the situation at the 20 cm distance spark gap will be slightly different from that at the other spark gaps.

The maximum overpressure, shown in Fig. 10b, is again higher for spark ignition than in case of flame jet ignition.

#### Results for a 76 mm Diameter Orifice

For the 76 mm diameter orifice the driving pressure (Fig.7) is only around 0.5 bar and two of the spark gaps are in a position which for a free jet would be within the quiet kernel. Here, however, the jet will already be influenced

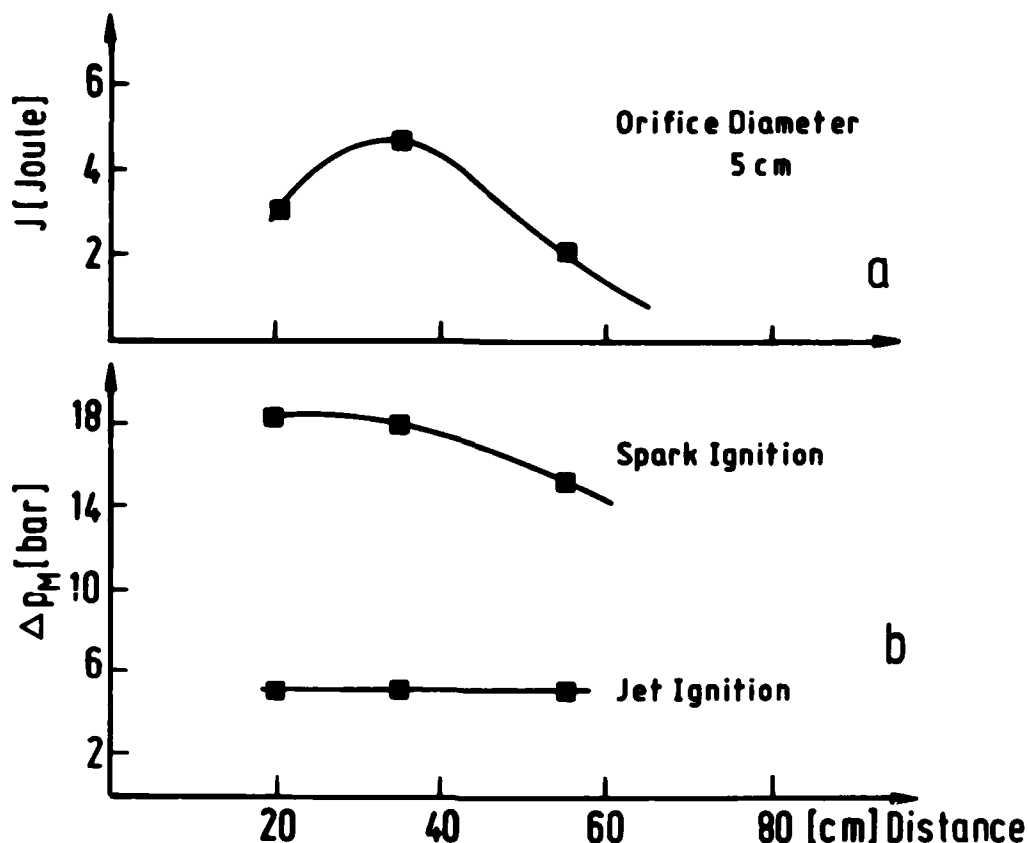

Fig. 10: Energies  $E$  necessary to ignite jet (10a) at distances given on the abscisse and maximum overpressures (10b) measured downstream of orifice. Orifice diameter 5cm.

by the recirculating flow around the jet. Nevertheless, the tendency of the  $E$  curve is different again, the absolute  $E$  values are lower, as to be expected.

The maximum pressures achieved, however, are still much higher than those for jet flame ignition (Fig. 11).

#### Results for 100 mm Diameter Orifices

A completely different situation arises for the 100 mm diameter orifice. Here, the energy  $E$  required to ignite the jet is below the level we could measure. The maximum overpressure is, however, still influenced resp. increased by

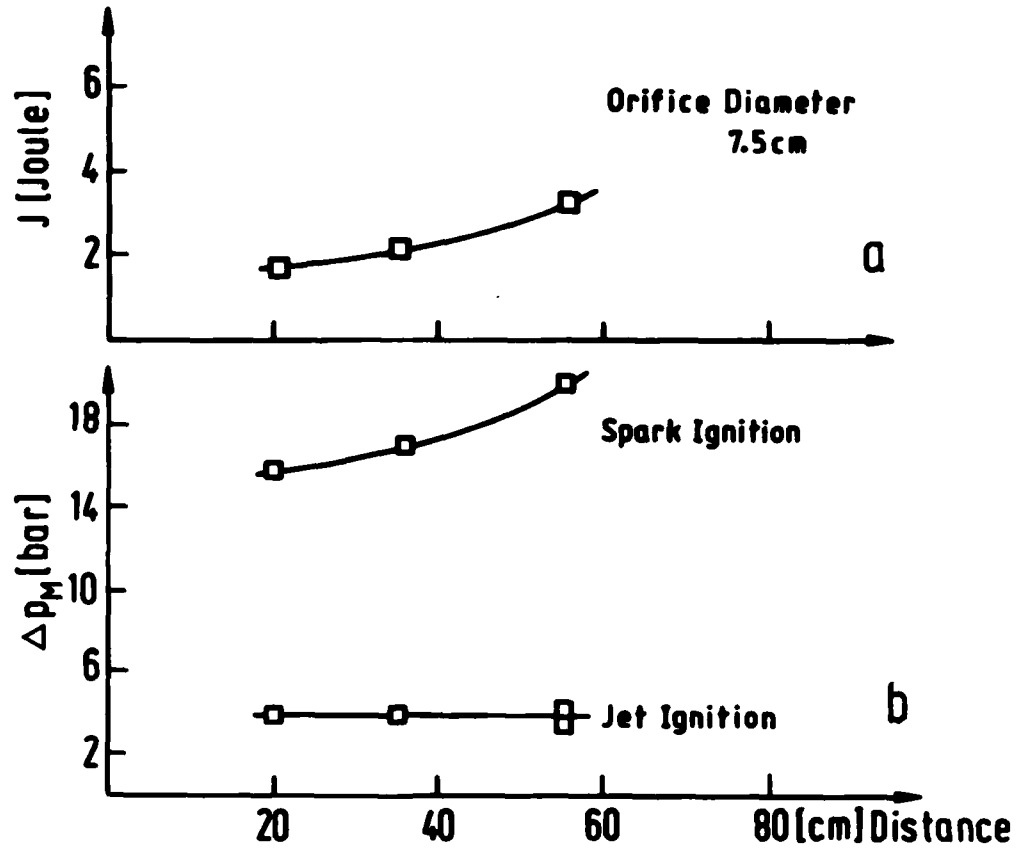

Fig. 11: Energies  $E$  necessary to ignite jet (11a) at distances given on the abscisse and maximum overpressures (11b) measured downstream of orifice. Orifice diameter 7.5cm

spark ignition, an indication that at larger distance from the orifice the turbulence of the flow is apparently in a more favourable state for combustion than close to the orifice. On the other hand, the position of the spark close to the middle of the tube allows full flame development into two directions.

#### Photographs of Spark Ignition in a Jet

A photograph of a  $E = 10$  WS spark is shown in Fig. 12, taken through a slit with a moving film. The luminous periphery extents to 6 cm after 1 ms. The light intensity of the spark is high so that the plexiglas window of the explo-

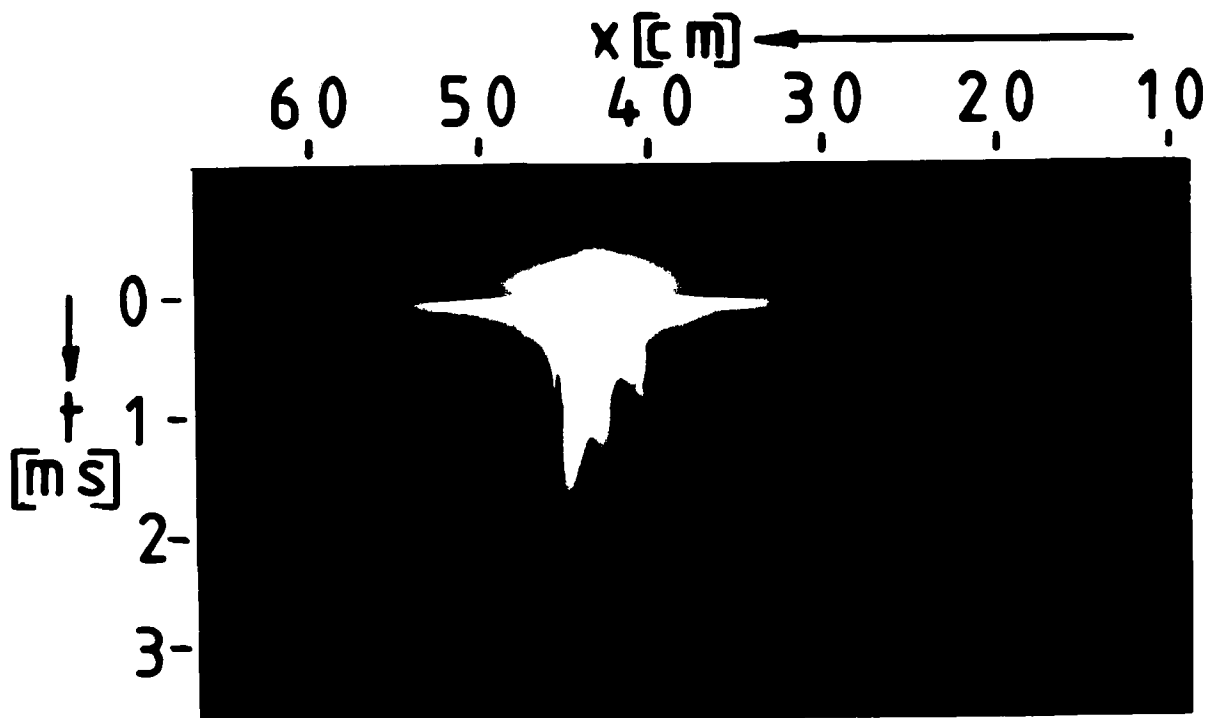

Fig. 12: Picture of the spark on a film at rest.

sion tube radiates along the whole tube.

A photograph of the ignition of a jet formed with a 50 mm diameter orifice and a distance of the spark gap of 35 cm from the orifice is reproduced in Fig. 13. The sketch of the pressure curves is shown in the lower left corner of Fig. 13. There, the spark is shown as the spike in the top line of the oscillogramme. The middle line gives the pressure signal downstream of the orifice (10 bar per division). On the lowest line the pressure time curve in the driver section is shown. The pressure rises to a steady level within which the spark is fired. One can recognize the delay of the pressure rise in the driver and the downstream section and its (relatively slow) decay. The time between maximum pressure

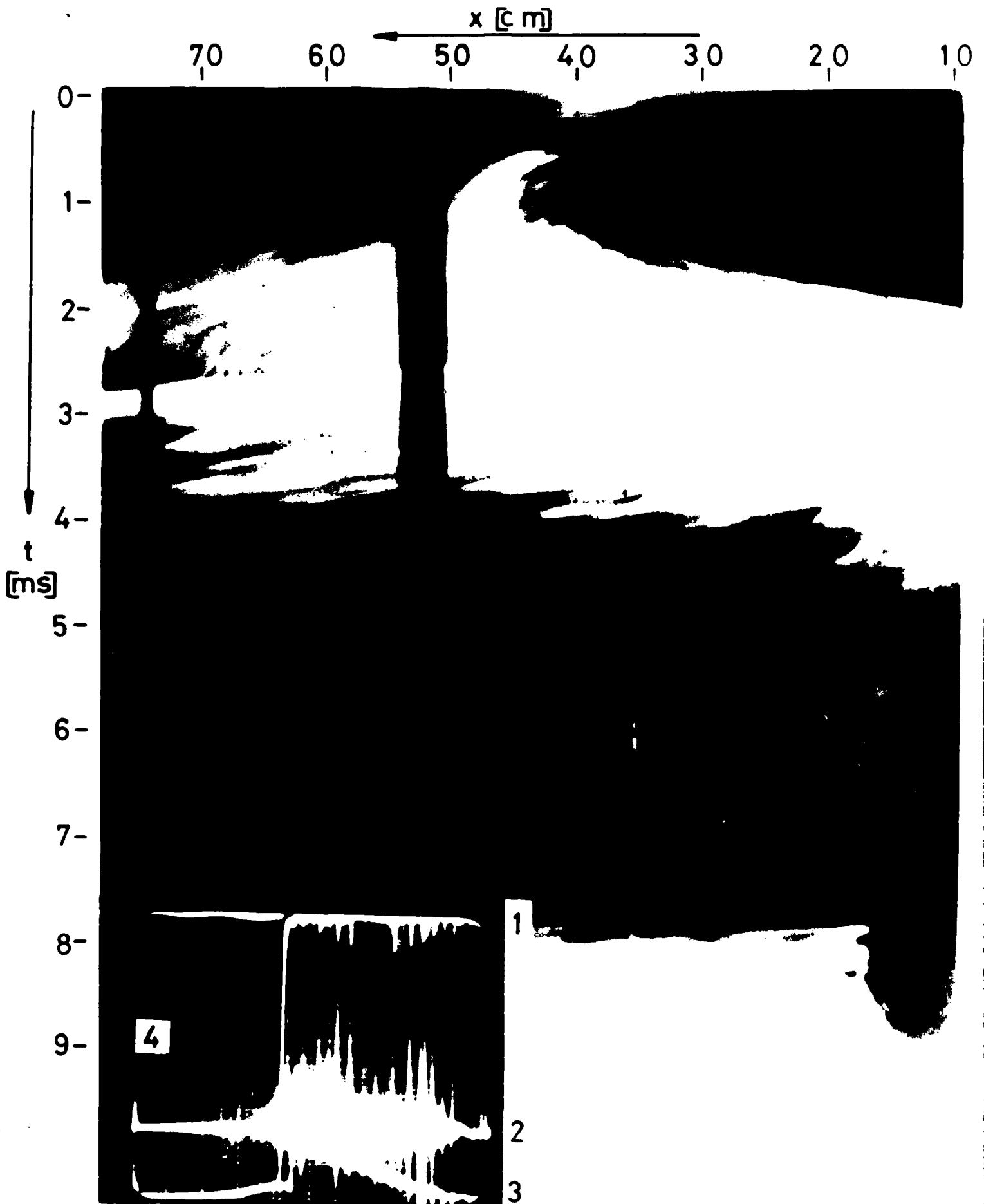

Fig.13: Smear camera picture and pressure record of a jet, ignited by a spark. Orifice plate on the right side. 1: spark; 2: Pres-

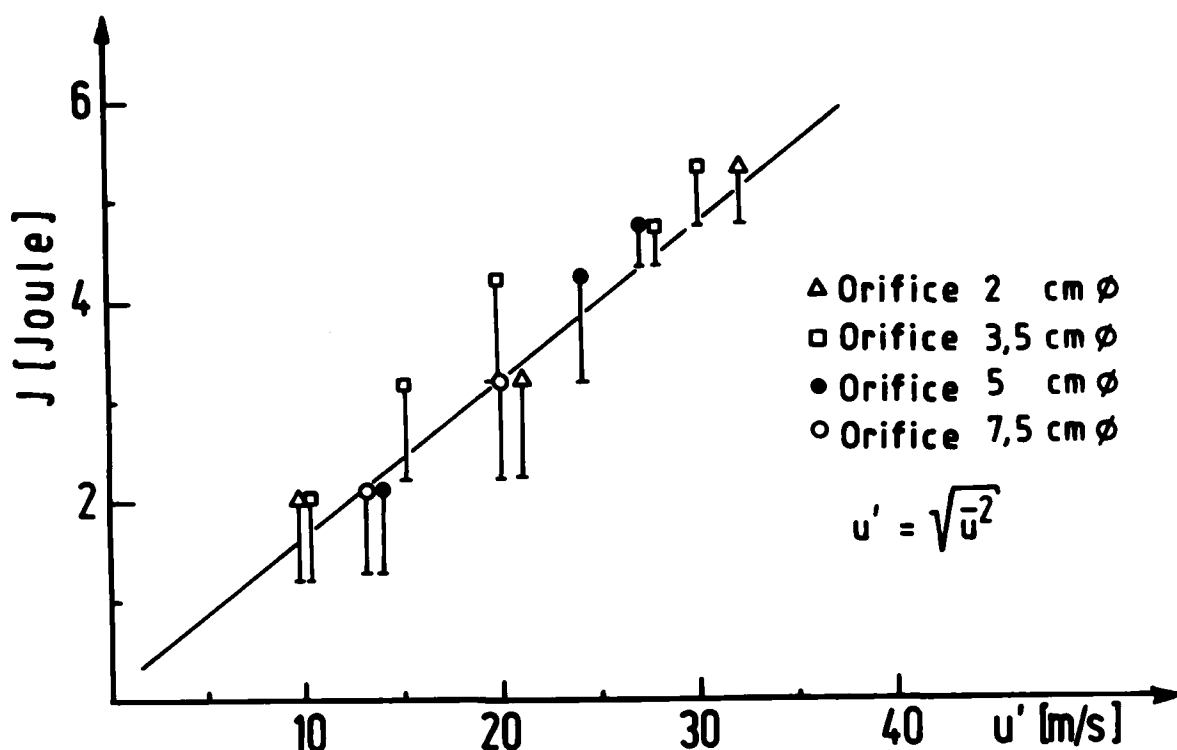

Fig. 14: Energy necessary to ignite the jet as a function of the fluctuation velocity at the spark gap.

in the downstream section and spark is about 1.5 ms. A time scale on the photograph of the explosion shows how far combustion has developed at the time of maximum pressure signal. The appearance of this ignition process on the film is different from that of ignition by a hot jet.

Immediately after firing the spark, the exposure shown on the film is due to the luminosity of the hot spark gases. This gas is blown towards the open end of the tube by the jet. The flame emerging from that highly exposed zone moves in both directions. At the beginning both flame path follow the jet flow and then the upstream side of the jet turns around and moves towards the orifice. In that stage gas of the outer part of the jet seems to have been involved in

combustion as indicated by the flame movement towards the orifice. After 1.5 ms the flame trace on the film corresponds to a propagation velocity of about 500 m/s on each side of the spark.

Later on, the trace of a shock wave moving towards the tube exit is visible on the photograph. (Speed 1500 m/s), complicated flow patterns arise and the hot gas is driven out by the jet which again comes out of the driver section.

Photographs of spark ignition in jets taken under different conditions are in principle similar.

The purpose of these experiments was to measure the propagation of flames in highly turbulent mixtures. On the basis of the measurements of Corrsin and Uberoi the mean turbulent fluctuation velocity  $\bar{u}'$  in jets can reach up to 22% of the local flow velocity. At high jet speeds fluctuation velocities up to about 50 m/s can, therefore, be reached in jets.

The time and space resolutions of the photographs taken until now are not high enough to allow a detailed evaluation of the propagation speed of the flame within the jet. They do indicate, however, that the flame velocity increases with increasing mean fluctuation velocity in the unburned gas in the jet. The evaluation of the flame speed at the very beginning suffers from the fact that with increasing jet speed increasing amounts of electric energy must be used in order to ignite the mixture.

Using the data of Corrsin et al. one can calculate the fluctuation velocities at different positions of the jet and therefore at the location of the spark gaps. An attempt to correlate the turbulent fluctuation velocities or the local flow velocities with the quantity  $E$  results in a fairly reasonable correlation between  $E$  and  $u'$  as shown in Fig.14. The bars give the scatter of different experiments. The curves contains, however, also points which should, due to the location of the spark gap, be located within the laminar kernel of the jet. As mentioned above, however, the spark gaps generate their own turbulence in their surrounding.

The values of  $E$  do not give the real ignition energy (see Experimental Set Up). From the data of Lefevre, who measured minimum ignition energies at low values of the fluctuation velocity around 1 m/s in the order of mJoule a linear extrapolation leads to ignition energies which are orders of magnitudes lower than those reported here. This is more than one would expect from the experience with other systems. One can give, however, arguments that towards these high speed conditions used here, larger energies should be required than those extrapolated from low fluctuation velocities. For a detailed discussion it is necessary, however, to obtain the real energy values put into the system. Experiments are under way.

REFERENCES

- 1 W. Jost and H. Gg. Wagner, "Influence of Various Parameters on Initiation, Stability and Limits of Detonations", Final Scientific Report AFOSR 79-0117A, 81 Dec. 31.
- 2 W. Jost and H. Gg. Wagner, "Influence of Various Parameters on Initiation, Stability, and Limits of Detonations", Final Scientific Report AFOSR 78-3587, 79 July 31.
- 3 J.H. Lee, D. Pangritz and H. Gg. Wagner, "Some General Considerations of the Initiation of Unconfined Detonations", MPI-Report No. 26/1976.
- 4 D. Pangritz and H.Gg.Wagner, "Ausbreitung sphärischer Flammen und ihre Beschleunigung an Drahtnetzen", MPI-Report No. 17/1977.
- 5 J.H. Lee, D. Pangritz and H.Gg.Wagner, "Beschleunigung instationärer Flammen in Rohren durch Blenden", MPI-Report No. 18/1977.
- 6 K.J. Dörge, D. Pangritz and H.Gg.Wagner, "Influence of Orifices on the Initiation of Detonations in Short Tubes", MPI-Report No. 108/1978.
- 7 R. Knystautas, J.H. Lee, I. Moen, and H. Gg. Wagner, "Direct Initiation of Spherical Detonation by a Hot Turbulent Gas Jet", Seventeenth Symposium (International) on Combustion, The Combustion Institute, 1978, p. 1235.

**END**

**FILMED**

**4-85**

**DTIC**