

AD-A150 665

SIX-INCH HYGE VERTICAL IMPACT FACILITY(U) AIR FORCE  
AEROSPACE MEDICAL RESEARCH LAB WRIGHT-PATTERSON AFB OH  
J A BROWN ET AL. AUG 84 AFAMRL-TR-84-039

1/1

UNCLASSIFIED

F/G 13/7

NL

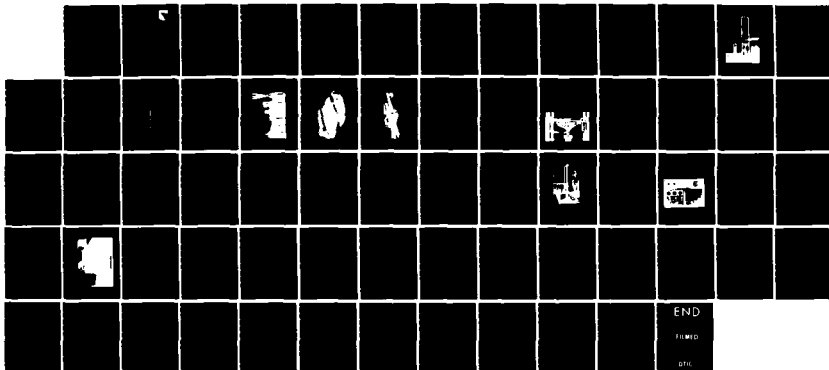

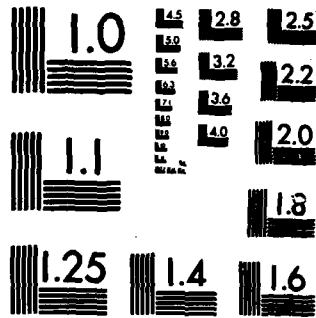

MICROCOPY RESOLUTION TEST CHART  
NATIONAL BUREAU OF STANDARDS-1963-A

AD-A150 665

AFAMRL-TR-84-039

2



SIX-INCH HYGE VERTICAL IMPACT FACILITY

JOHN A. BROWN  
FRANCIS D. DODGE, MSGT, USAF, RETIRED

AUGUST 1984

Approved for public release; distribution unlimited.

DTIC FILE COPY

AIR FORCE AEROSPACE MEDICAL RESEARCH LABORATORY  
AEROSPACE MEDICAL DIVISION  
AIR FORCE SYSTEMS COMMAND  
WRIGHT-PATTERSON AIR FORCE BASE OHIO 45433

S  
FEB 28 1985  
A

85 02 12 15

## NOTICES

When US Government drawings, specifications, or other data are used for any purpose other than a definitely related Government procurement operation, the Government thereby incurs no responsibility nor any obligation whatsoever, and the fact that the Government may have formulated, furnished, or in any way supplied the said drawings, specifications, or other data, is not to be regarded by implication or otherwise, as in any manner licensing the holder or any other person or corporation, or conveying any rights or permission to manufacture, use, or sell any patented invention that may in any way be related thereto.

Please do not request copies of this report from Air Force Aerospace Medical Research Laboratory. Additional copies may be purchased from:

National Technical Information Service  
5285 Port Royal Road  
Springfield, Virginia 22161

Federal Government agencies and their contractors registered with Defense Technical Information Center should direct requests for copies of this report to:

Defense Technical Information Center  
Cameron Station  
Alexandria, Virginia 22314

### TECHNICAL REVIEW AND APPROVAL

AFAMRL-TR-84-039

This report has been reviewed by the Office of Public Affairs (PA) and is releasable to the National Technical Information Service (NTIS). At NTIS, it will be available to the general public, including foreign nations.

This technical report has been reviewed and is approved for publication.

**FOR THE COMMANDER**



HENNING E. VON GIERKE, Dr Ing  
Director  
Biodynamics and Bioengineering Division  
Air Force Aerospace Medical Research Laboratory



UNCLASSIFIED

SECURITY CLASSIFICATION OF THIS PAGE

Block 19, continued

electronic and motion picture photographic coverage. Elements in the operation of the facility operator's and safety monitor's stations during automatic control or manual test mode are discussed. Maintenance aspects are also discussed. The appendices include operating instructions and safety precautions for each of the operators during set-up and operation of the test facility.

B

UNCLASSIFIED

SECURITY CLASSIFICATION OF THIS PAGE

PREFACE

This report was prepared by the Biomechanical Protection Branch, Biodynamics and Bioengineering Division of the Air Force Aerospace Medical Research Laboratory. The work was performed in support of Project 7231, "Biodynamics of Aerospace Operation," Task 723116, "Impact Exposure Limits and Personnel Protection Criteria."

Recognition is due Mr Ronald Riddle and Mr Harold Boedecker of the Dynalectron Corporation who are responsible for the electronic aspects of the instrumentation system.

Recognition is also given to Mrs Sarah Mosley for her administrative support in the preparation of the report.

Accession For	
NTIS GRA&I	<input checked="" type="checkbox"/>
DTIC TAB	<input type="checkbox"/>
Unannounced	<input type="checkbox"/>
Justification	
Distribution/	
Availability Codes	
Avail and/or	
Dist	Special
A-1	

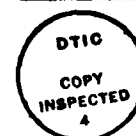

## TABLE OF CONTENTS

	Page Number
PREFACE . . . . .	1
TABLE OF CONTENTS . . . . .	2
LIST OF ILLUSTRATIONS . . . . .	3
LIST OF TABLES . . . . .	3
SUMMARY . . . . .	4
INTRODUCTION . . . . .	5
Background . . . . .	5
General Facility Description . . . . .	6
ACTUATOR AND CARRIAGE SYSTEM . . . . .	6
General Operating Principle . . . . .	6
Actuator . . . . .	9
Carriage . . . . .	19
Rail System . . . . .	21
Performance . . . . .	21
Support Elements . . . . .	22
PROGRAM PLANNING . . . . .	23
Theoretical Considerations . . . . .	23
Practical Considerations . . . . .	27
INSTRUMENTATION SYSTEM . . . . .	29
Pressure Measurements . . . . .	29
Inertial Measurements . . . . .	30
Data Transmission . . . . .	30
Signal Processing . . . . .	31
Recorder . . . . .	31
Data Display . . . . .	31
Timing Control . . . . .	33
PHOTOGRAPHIC COVERAGE . . . . .	33
OPERATION AND SAFETY SYSTEMS . . . . .	35
Automatic Control . . . . .	35

TABLE OF CONTENTS - Continued

	Page Number
Facility Operator's Station . . . . .	35
Safety Monitor's Station . . . . .	36
Manual Test Mode . . . . .	36
Autofire . . . . .	37
<b>DATA REDUCTION SYSTEMS . . . . .</b>	<b>37</b>
Requirements . . . . .	37
Quick Look . . . . .	37
Data Processing . . . . .	39
<b>MAINTENANCE . . . . .</b>	<b>39</b>
<b>APPENDICES</b>	
I. Operating Instructions . . . . .	42
II. Test Log . . . . .	60
<b>REFERENCES . . . . .</b>	<b>61</b>

LIST OF ILLUSTRATIONS

Figure		Page
1	Six-inch Vertical Impact Facility, System Site Installation . .	7
2	Diagram of Actuator, Carriage, and Rail System . . . . .	8
3	Six-inch Vertical Actuator Assembly Configurations . . . . .	10
4	Shock Actuator Assembly, Type HY-6407 . . . . .	11
5	Acceleration Metering Pins . . . . .	13
6	Deceleration Metering Pins . . . . .	14
7	Dynamic Parts . . . . .	15
8	Specimen Carriage with Rail Columns . . . . .	18
9	Theoretical Thrust-Displacement Curves . . . . .	26
10	Pneumatic Diagram . . . . .	28
11	Photographic Cameras and Lighting . . . . .	32
12	Operation and Safety Console . . . . .	34
13	Computer . . . . .	38

LIST OF TABLES

Table		Page
1	Vertical Actuator Physical Properties . . . . .	17
2	Demonstrated Performance . . . . .	20

## SUMMARY

The six-inch vertical impact facility was activated at AFAMRL in 1977. The vertical impact facility assembly consists of a pneumatic-hydraulic actuator, a 20-foot rail system, specimen carriage, and several support elements complemented by instrumentation, operation and safety instructions, and data-reduction systems. This report describes the operating principles of the vertical impact facility and provides illustrations to assist the reader in the definition of actuator configurations, selection of acceleration and deceleration metering pins, and establishment of operating conditions. The carriage specimen-mounting pattern and specimen weight limits are provided as criteria for the design of test fixtures. A demonstrated performance table permits comparison of test results as a function of input parameters for several actuator configurations. Statistical results demonstrate the high degree of repeatability of the vertical impact facility's performance.

The acceleration waveforms may be developed using formula coefficients, or by the manufacturer's nomograph and thrust-displacement curve. A list is provided of physical inputs to change in order to obtain a desired change in resultant performance parameters.

The pneumatic circuitry of the operator's console is diagrammed to illustrate control and flow of the nitrogen supply. Accelerometers, data transmission, signal conditioning, data recording, and quick-look data display equipment are documented along with the timing control which coordinates the activation and collection of the electrical, electronic and motion picture photographic coverage. An illustration is provided of one type of off-board photographic coverage.

Salient elements in the operation of the facility operator's and safety monitor's stations during automatic control, manual test mode, or autofire testing are discussed to emphasize operating rational and safety requirements.

Maintenance is discussed with concern for instructions, documentation, safety, tools and equipment, performance intervals, procedures, and the performance of signature tests. The appendices of this report document operating instructions and safety precautions for each of the operators during set-up and operation of the test facility and for a program that requires the rapid return of the test specimen to the principal investigator following the test event.

## INTRODUCTION

The Vertical Impact Test Facility is located in the Air Force Aerospace Medical Research Laboratory (AFAMRL) at Wright-Patterson Air Force Base, Ohio. This vertical impact facility is one of a family of impact facilities at AFAMRL used to investigate human impact exposure limits and conduct exploratory research and development of impact protection equipment. The vertical impact facility is also used to conduct impact tests of small equipment components, such as instrumentation transducers, and to evaluate the dynamic response of impact-attenuating materials.

The vertical impact facility is capable of a maximum thrust of approximately 40,000-pound force at a 2-inch displacement and approximately 20,000-pound force at a 10-inch displacement. This device is one of a series of pneumatic-hydraulic accelerators, described as 3-inch, 6-inch (1a), 12-inch, and 24-inch HYGE shock testers designed and built by CVC Products, Incorporated, formerly known as Consolidated Electrodynamics Corporation. The 6-inch HYGE, the largest of the series that is vertically oriented, has the ability to utilize both acceleration and deceleration metering pins. The deceleration pin permits control of the terminal portion of the acceleration profile.

### Background

Until 1969, Air Force impact investigations were carried out jointly by the Aeromedical Research Laboratory (ARL) at Holloman Air Force Base, New Mexico, and the Aerospace Medical Research Laboratory (AMRL) at Wright-Patterson Air Force Base, Ohio. ARL was responsible for most of the crash-injury research and carried out this function using a linear deceleration track known as the Daisy Decelerator as its primary facility. In September 1960, a 6-inch vertical impact facility was added to the ARL impact facilities (2). The vertical impact facility was made operational in May 1961, and on 22 December 1961 the first human subjects were tested. AMRL concentrated its research on ejection-seat safety and provided the interface between the aerospace medical community and the systems development programs handled by the Aeronautical Systems Division, also at Wright-Patterson Air Force Base. AMRL test facilities were vertical drop facilities which are useful for studying ejection accelerations.

With the deactivation of ARL, the 6-inch vertical impact facility, the subject of this report, was dismantled and shipped to the Wright-Patterson facility. A suitable foundation was constructed, and the facility base plate, 20-foot vertical rails, carriage system, and control system were installed. Necessary changes to the pneumatic control system were accomplished between August 1975 and November 1976. The first test was conducted in March 1977.

## General Facility Description

The 5-inch vertical impact facility is shown in Figure 1. The four major components of the facility are:

- (1) 6-inch vertical actuator, 20-foot rail system, specimen carriage, and support elements
- (2) Instrumentation system
- (3) Operation and safety systems
- (4) Data reduction systems

The vertical pneumatic actuator produces a single-event impact profile according to a predetermined acceleration-time profile which is imparted to the specimen carriage. It, in turn, is constrained to move upward on the vertical rail system.

The instrumentation system provides the means to collect and record data on the impact environment and test-article responses. It is designed to handle many different types of transducers.

The operation and safety systems provide the actuators for safely operating the facility and for activating the electronic master clock which controls and synchronizes the operation of the trigger pressure solenoid valve and all other subsystems.

The data reduction system provides several means for storing and processing the collected data for subsequent documentation. Some of the reductions are handled on-line with the impact event, while others are designed for post-test examination.

The following sections describe the operational details and guiding philosophies behind each of the systems and the interrelations among them. Subsequent sections and appendices will describe mechanical maintenance requirements, detail local operating instructions, and discuss briefly pertinent computer programs.

## ACTUATOR AND CARRIAGE SYSTEM

### General Operating Principle

A diagram of the vertical impact facility system is shown in Figure 2. The system consists of the HYGE actuator, specimen carriage, and a pair of rail columns. The actuator produces upward thrust by means of differential gas pressures acting on opposite faces of a thrust piston in a closed system envelope consisting of two or more cylinders and a mount base. The thrust piston assembly includes a thrust column and a selected acceleration metering pin. The top cylinder is first pressurized (set pressure) forcing the thrust piston and a captive orifice seal O-ring down against the acceleration orifice

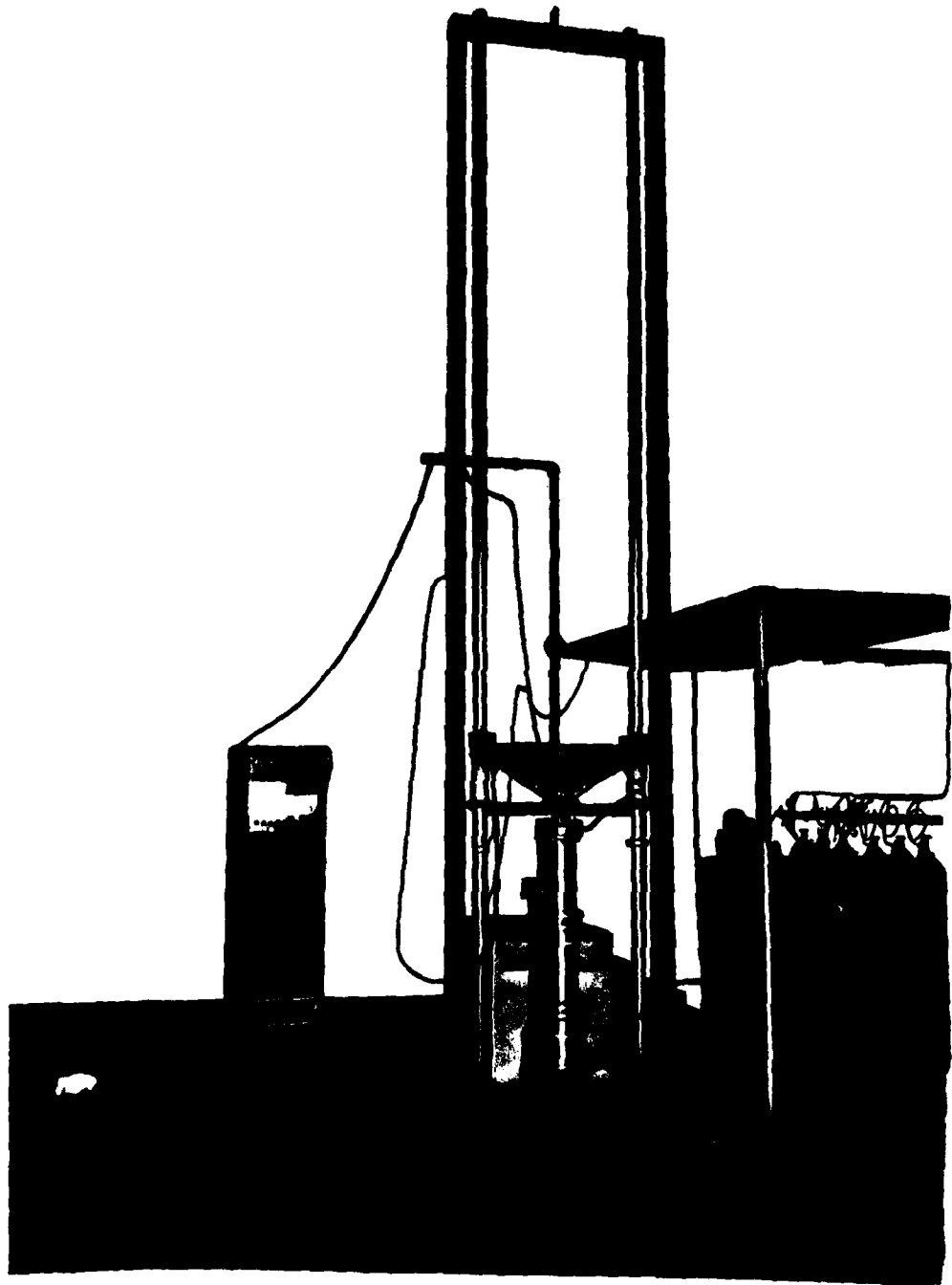

Figure 1. Six-inch Vertical Impact Facility. System Site Installation.

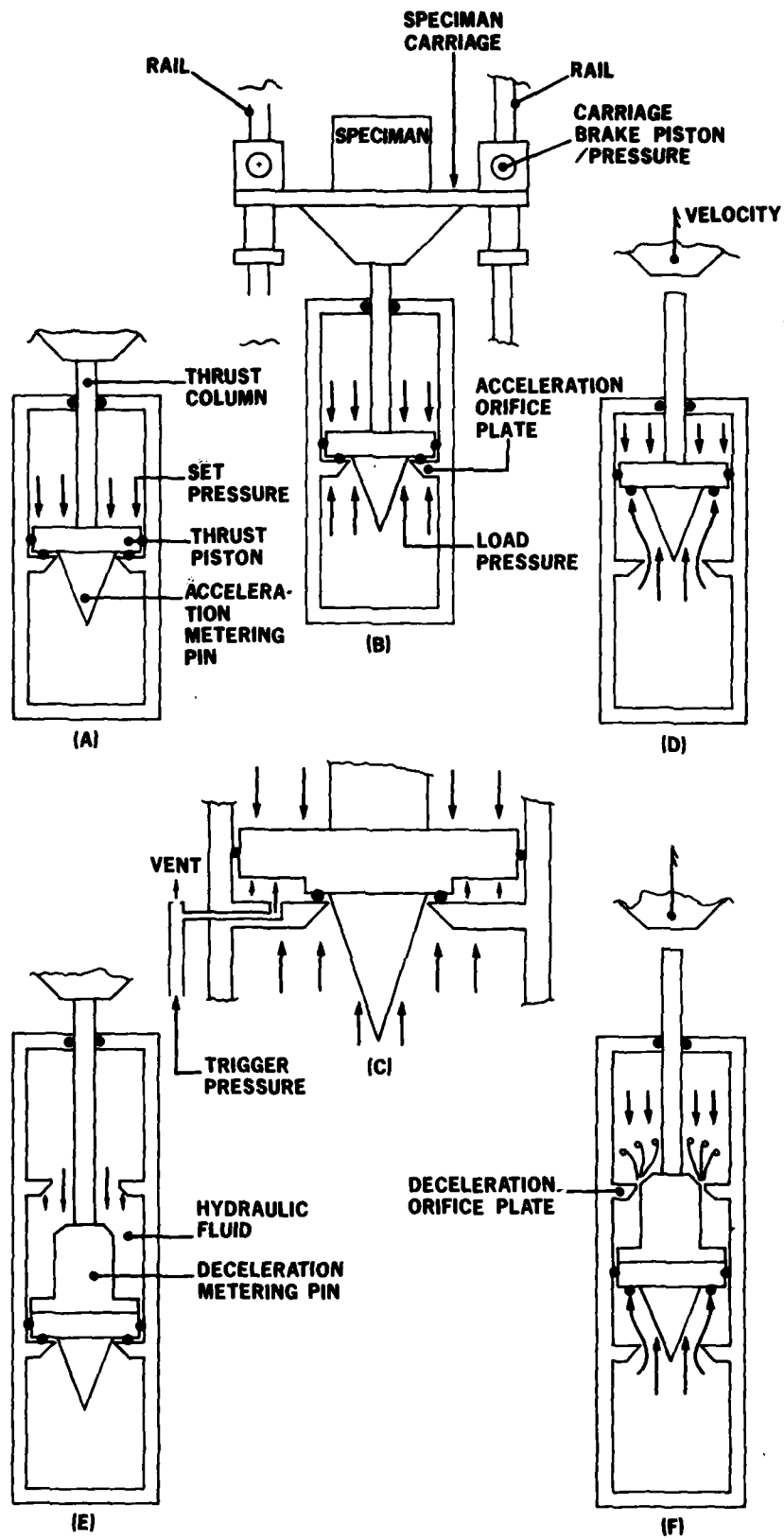

FIGURE 2. DIAGRAM OF ACTUATOR, CARRIAGE AND RAIL SYSTEM.

plate (A) and (E). The specimen carriage is brought into contact with the thrust column, and carriage brakes are pressurized. The bottom cylinder is then pressurized (load pressure); however, this pressure is effective against the thrust piston only across the area of the acceleration orifice (B). Gauge pressure ratios normally used are 5:1, 5.5:1, and 6:1 (load gauge pressure:set gauge pressure). These ratios ensure static pre-test conditions. The theoretical maximum load gauge pressure is determined from balanced force calculations utilizing absolute pressures multiplied by the relevant areas.

A start-up (trigger) pressure is introduced into the very small volume between the bottom of the thrust piston and the top of the acceleration orifice plate. This pressure is sufficient when added to the pressure at the acceleration orifice to exceed the opposing pressure causing the thrust piston to move upward (C). The acceleration orifice seal becomes unseated, permitting the bottom cylinder pressure to spread across the bottom face of the thrust piston. The flow of the bottom cylinder high-pressure nitrogen is metered through the annular ring created by the acceleration plate orifice and the vertically contoured face of the acceleration metering pin. This contoured face is responsible for the resultant acceleration waveform that is generated (D).

The acceleration phase of the event terminates when the specimen carriage separates from the thrust column. At this point the carriage velocity is maximum and its acceleration displacement is complete. The upward velocity of the carriage is brought to zero using a pair of carriage brakes that bear against each vertical rail column. The thrust piston assemblage continues to move upward after carriage separation. The adiabatic compression of the top cylinder of nitrogen quickly stops the upward velocity of the piston assemblage; at this point the piston experiences a deceleration that is approximately six times as great as the positive acceleration shared earlier with the specimen carriage.

A deceleration metering pin is added to the thrust piston assemblage when an abrupt rate of decay of the acceleration-time profile is desired. A second top cylinder and a second orifice plate are also added to the system envelope. The second orifice plate is used as a deceleration orifice. The deceleration medium is hydraulic fluid (F).

### Actuator

Figure 3 illustrates various 6-inch actuator assembly configurations. The Series 6100 configurations utilize the acceleration metering pin and orifice. Series 6400 configurations utilize, in addition, the deceleration metering pin and orifice and the hydraulic deceleration medium. The Series 6600 configuration (HY-6601) is a variation selected by AFAMRL personnel. Figure 4 is a detailed illustration of the HY-6407 shock actuator assembly. This figure shows all items of the most complicated system assembly and is provided to serve as a reference to nomenclature used within this report.

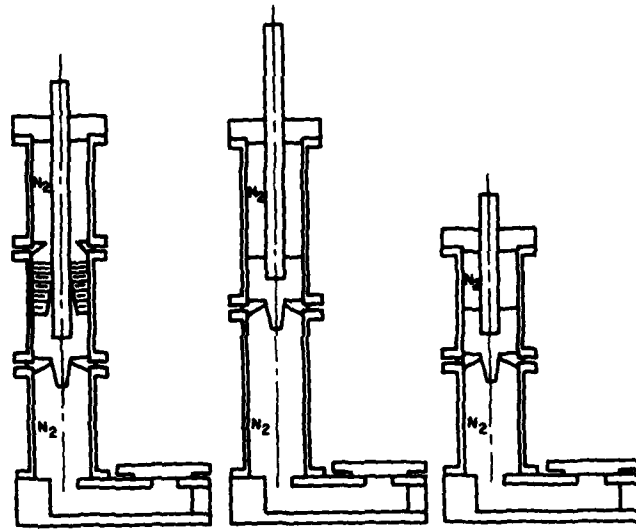

HY-640I

HY-6134

HY-613I

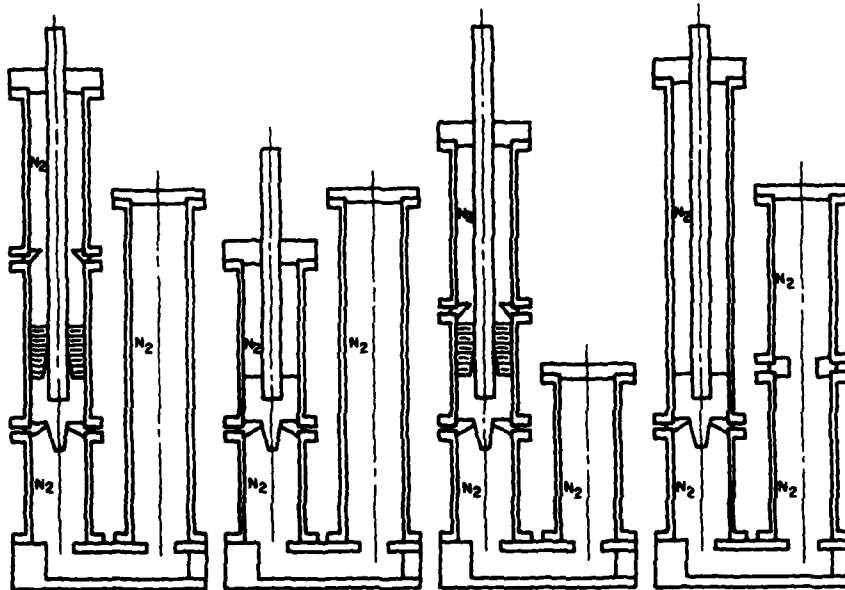

HY-6407

HY-660I

HY-6423

HY-6136

**FIGURE 3. 6-INCH VERTICAL ACTUATOR ASSEMBLY CONFIGURATIONS.**

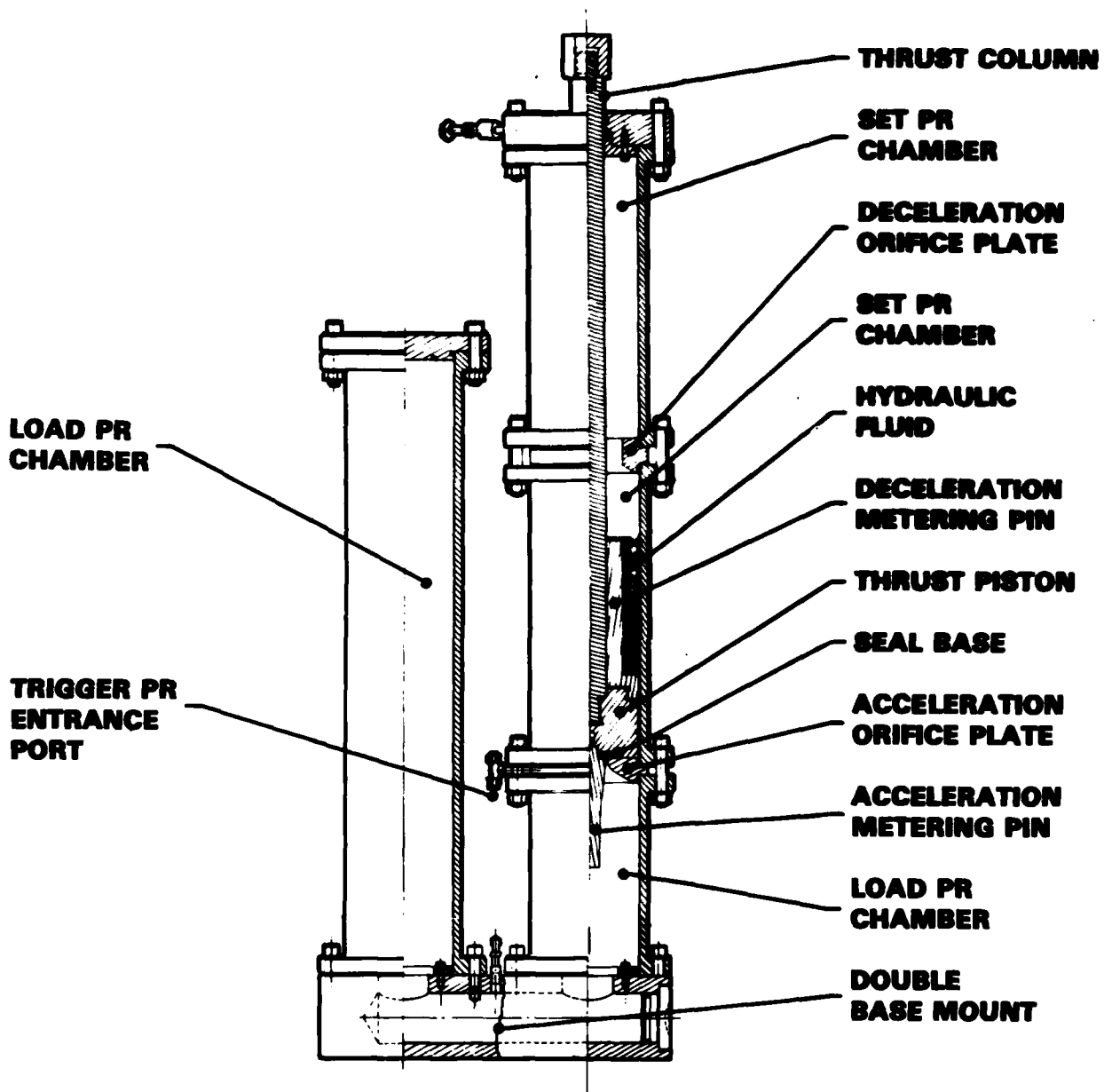

**FIGURE 4. SHOCK ACTUATOR ASSEMBLY. TYPE HY-6407.**

The inside diameter of all cylinders is six inches. The cylinders are 12, 18, and 37 inches long with a wall thickness of  $\frac{1}{2}$  inch. The thrust columns are 15, 27.5 and 40 inches long by 2 inches diameter.

The load pressure chamber consists of the volume of the bottom cylinder below the acceleration orifice plate together with the internal volume of the double mount base and any parallel connected cylinder(s). The set pressure chamber consists of the volume of the cylinder(s) in which the thrust column is located.

The thrust piston is limited to travel within the length of one cylinder. The Series 6100 and 6600 configurations use only one set pressure cylinder. Piston travel is between the top of the acceleration orifice plate and the top cover of the set pressure cylinder. The Series 6400 configurations use two set pressure cylinders separated by the deceleration orifice plate. Piston travel is between the two orifice plates. The shortest possible thrust column is used for the desired configuration to help minimize the weight being accelerated during the impact. The column is threaded into the top of the thrust piston and extends through the set pressure cylinder, or cylinders, through the cylinder cover and threads into a cap. The cap butts against the bottom of the specimen carriage, both in the ready stage and during the positive acceleration stage of carriage travel.

Figures 5 and 6 illustrate the available acceleration and deceleration metering pins. Figure 7 illustrates the dynamic components of the actuator. The locking collar is used when the No. B-262141 deceleration metering pin is not used. A selected acceleration metering pin shoulders against the seal plate and is threaded into the bottom face of the thrust piston.

The initial portion of the contoured face of the acceleration metering pin below the seal plate is responsible for the rate of onset of the acceleration profile. Of the tests accomplished through February 1979 (170), the rate of onset was complete within a 0.2-inch displacement for 60 percent of the tests. The rate of onset was complete within 0.5 inch for 85 percent of all tests and within 1.0 inch for all tests. When it is used, the deceleration metering pin is located on top of the thrust piston, around the thrust column. It is either threaded to the top shoulder of the thrust piston for the No. B-262141 pin or clamped to the top of the thrust piston by a locking collar for the No. B-261840 pin. The deceleration orifice plate is positioned with its contour down for the No. B-262141 pin or with its contour up for the No. B-261840 pin. The hydraulic deceleration medium must be maintained above the top of the deceleration metering pin at the level specified by the manufacturer. When the system is operated with the dual metering pins, the final acceleration stage has the thrust piston forcing the hydraulic fluid through the deceleration orifice. In this case, the net flow area is controlled by the vertical contour of the deceleration metering pin. Back pressure through the hydraulic fluid, acting against the top face of the piston, provides rapid controlled deceleration of the internal actuator components (1a).



FIGURE 5. ACCELERATION METERING PINS.

PIN B-262141

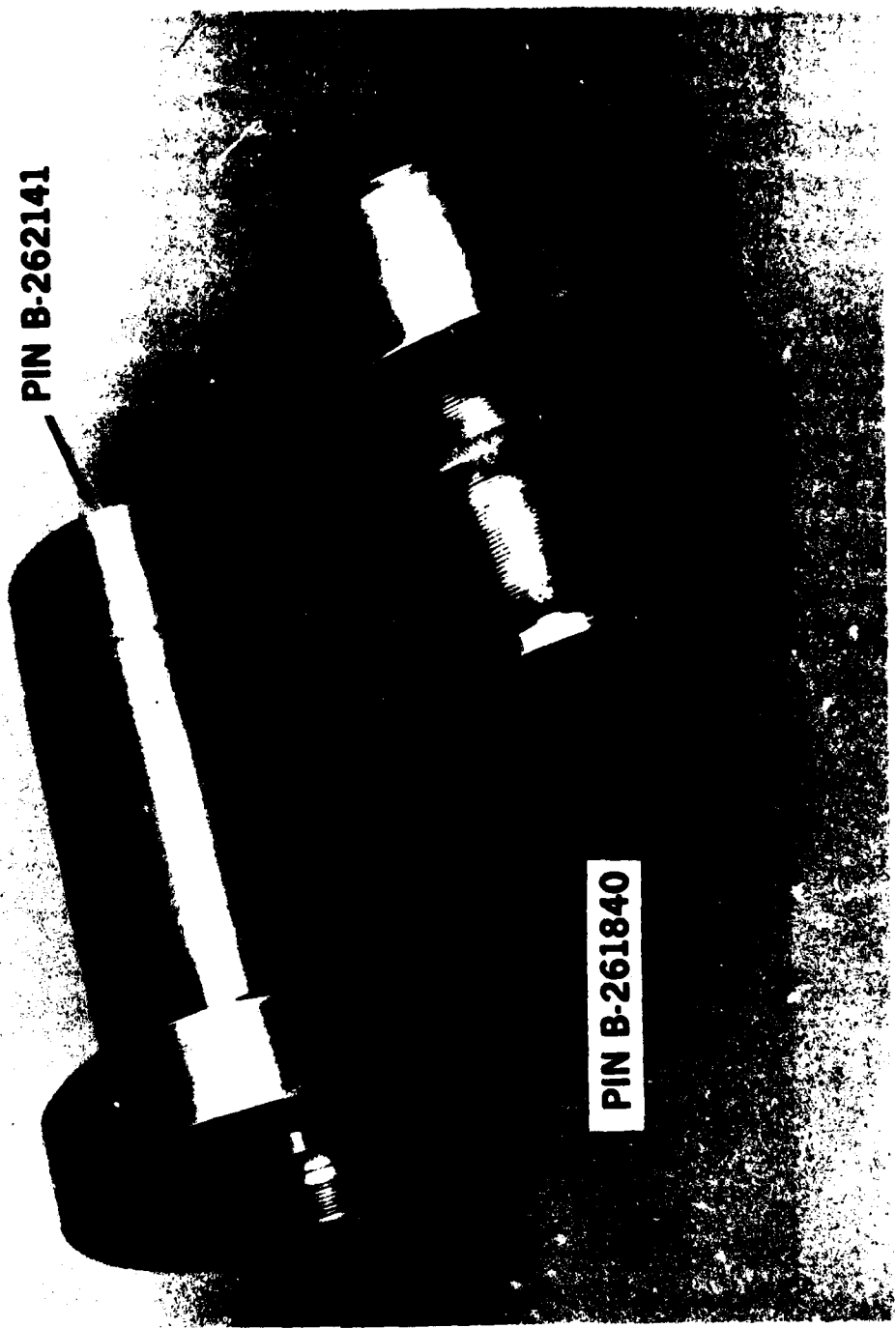

PIN B-261840

FIGURE 6. DECELERATION METERING PINS.

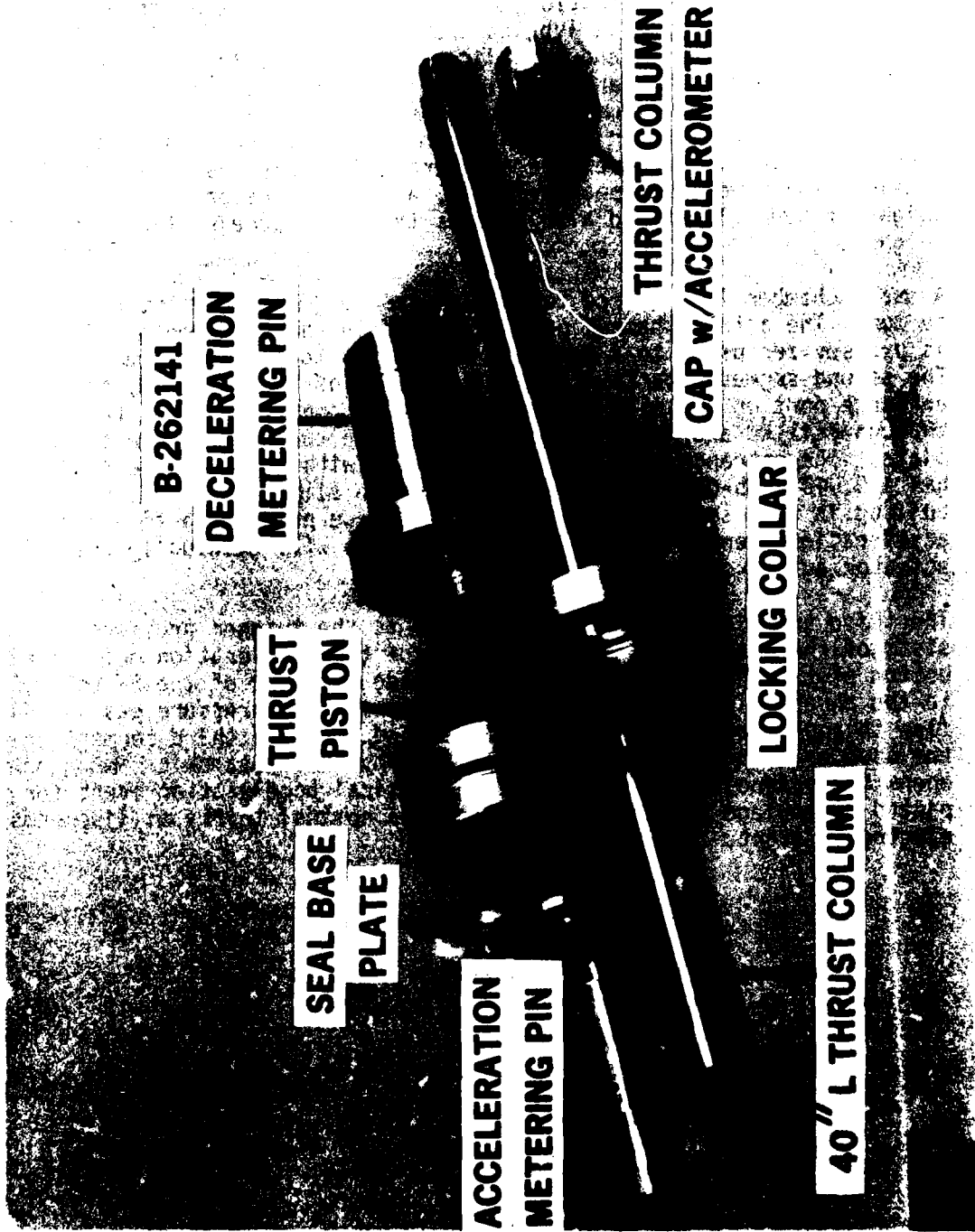

FIGURE 7. DYNAMIC PARTS

Water-pumped nitrogen is used in all pressurized segments of the vertical accelerator system, including the carriage brakes. Cylinders of the 1A type (2200 psig) are used. The properties of nitrogen insure against dieseling, permit the use of a selected petroleum-base hydraulic fluid medium, and allow the use of Buna O-ring seals. The internal hydraulic fluid serves three functions: (1) it acts as the deceleration medium when the deceleration metering pin is employed; (2) it acts as a lubricant between the inner wall of the set pressure cylinder and the O-ring and phenolic bearing of the thrust piston (a minimum height of  $\frac{1}{4}$  inch of hydraulic fluid (approximately 0.2 liters) above the top of the thrust piston is recommended); and (3) it decreases the effective height of the set pressure cylinder when added in excess of the minimum lubrication quantity. This in turn reduces the acceleration stroke displacement affecting the acceleration time base, peak velocity, and peak acceleration. The additional weight of hydraulic fluid also affects the total acceleration and deceleration weights.

A small chamber is required to provide passage for the start-up trigger pressure medium. The actual chamber used is staged in three segments. The first segment is pressurized prior to a test and extends up to an electrical solenoid valve. The second segment starts at the output side of the solenoid, fastens to an entrance port on the side of the acceleration orifice plate, and continues through drilled and joined holes in the plate to an exit hole on the top of the plate. The entrance port has a tee fitting with a cap on the dead end. The cap has a 0.040-inch-diameter hole on the top to eliminate a possible slow pressure buildup in this segment due to in-flow leakage prior to activation of the acceleration event. (A slow pressure buildup will eventually result in an actuator autofire.)

The third and final segment, referred to as the trigger pressure chamber, consists of the chamber bounded by the top of the acceleration orifice plate, the bottom of the thrust piston, and the inside diameter of the 6-inch cylinder up to the thrust piston O-ring. The start-up trigger pressure gas is allowed to flow through the second segment chamber and into the third segment chamber after the acceleration event has been initiated by the electronic timing control which opens the solenoid valve. The actual physical acceleration event for the thrust piston assemblage and carriage starts at a nominal thirty milliseconds after the electronic start.

TABLE 1. VERTICAL ACTUATOR PHYSICAL PROPERTIES

	LOAD CHAMBER	THRUST CHAMBER	SET CHAMBER
Net Area (sq in)	3.14	28.27	25.13
Maximum Pressure (psig)	2000	3000 (Surge)	3000 (Surge)

The thrust chamber is the volume created between the acceleration orifice plate and the bottom of the thrust piston when the piston is displaced during firing. This volume includes the trigger chamber. The volume of the thrust chamber is at the expense of the set chamber volume. The maximum pressure listed for the set chamber is the peak surge pressure allowed during thrust column deceleration (3). The set chamber area is the full inside area minus the cross sectional area of the thrust column. The area given for the load chamber is the orifice area through which all load gas must pass to be effective against the full thrust piston surface area. These area values yield area ratios of 8.0 (set/load) prior to firing and 0.89 (set/thrust) during the acceleration pulse. These values state in theory that the absolute pressure in the load chamber may be 8.0 times the absolute pressure in the set chamber without causing an auto-fire, and an absolute pressure in the thrust chamber of 0.89 times the absolute pressure will cause the thrust column to move. In practice, the autofire ratio is approximately 6.2. Consideration of the absolute ambient pressure found in the trigger pressure chamber drastically lowers the theoretical autofire ratio. Other factors affecting the autofire ratio include operating pressures, seal base geometry, friction of piston and thrust column bearings and seals, brake pressure and friction, and total accelerated weight.

The following operating trigger pressures have been empirically developed:

Load Pressure (psig)	Trigger Pressure (psig)
to 149	100
150 - 199	150
200 and above	200

When the trigger pressure is below 70 psig, the valve activation is delayed more than 30 milliseconds. When the trigger pressure is above 300 psig, the solenoid valve action is erratic.

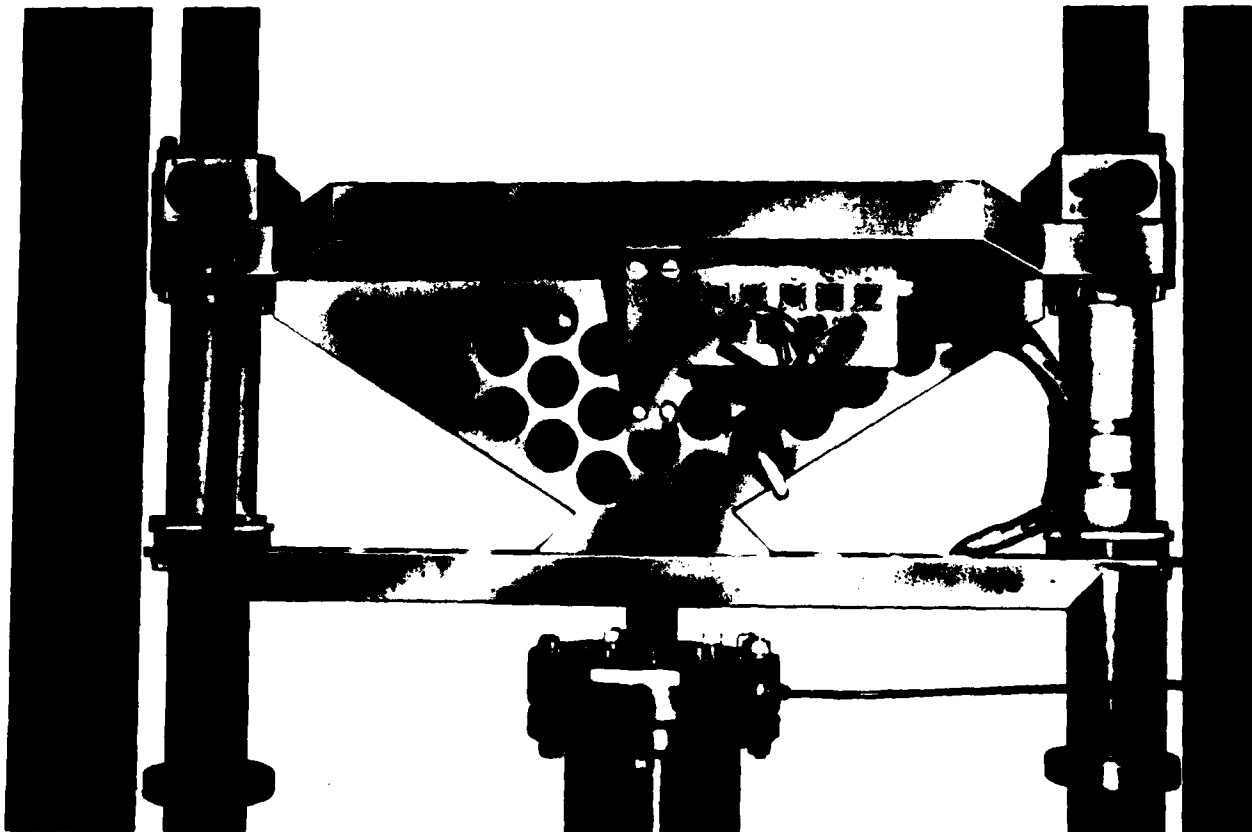
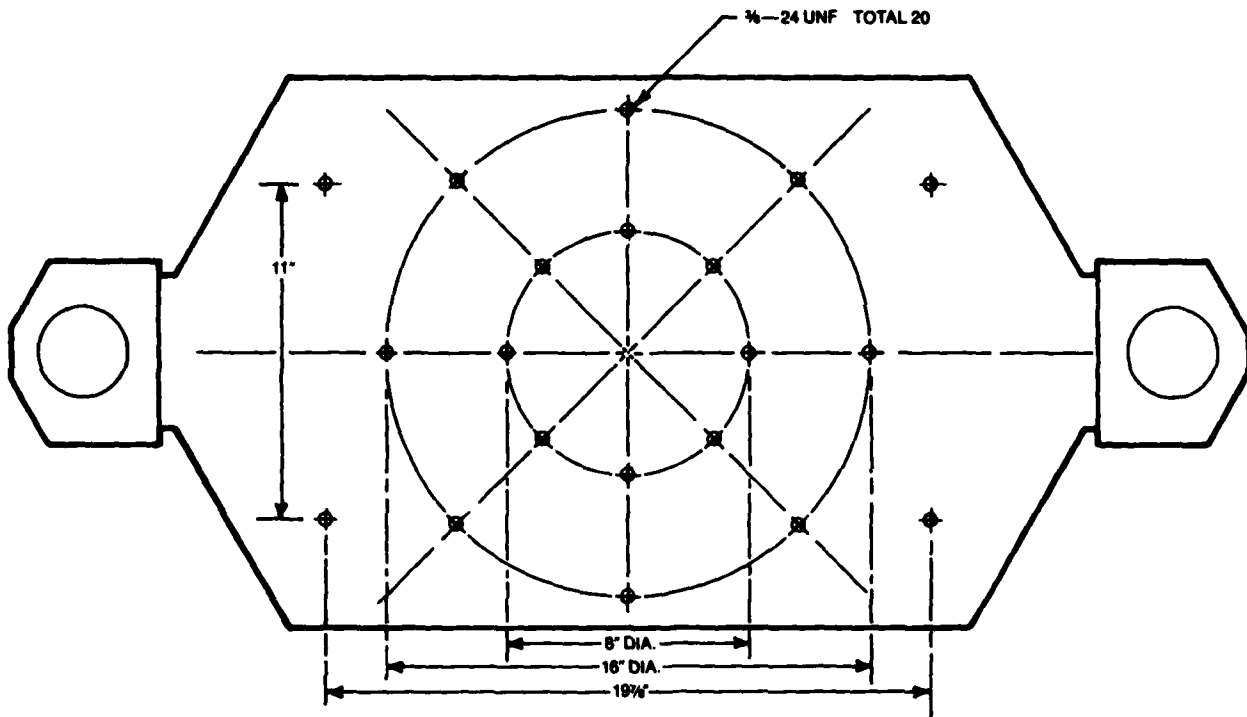

FIGURE 8. SPECIMEN CARRIAGE WITH RAIL COLUMNS.

## Carriage

Figure 8 illustrates the specimen carriage and portions of the rail column. The specimen carriage platform and two 6-inch-high carriage stiffeners are fabricated from 2-inch-thick magnesium plate; the 10-inch-high rail-to-rail stiffener from 2.5-inch-thick magnesium plate, and the carriage brake housings and tube supports from magnesium. The platform underside is counterbored, and the stiffening members drilled to minimize weight. The carriage resonant frequency is designed to occur in the range of 800-1000 hertz. Modification and repairs have lowered the resonant frequency to the range of 550-700 hertz. The assembly weighs 87.5 pounds, including TFE bearings, bearing retainers, support tubes, brake pistons, seals, and linings with an additional 5.6 pounds added by X-, Y-, and Z-axis accelerometers and an instrumentation cable box. The cross-brace modification attached to the bottom end of the support tubes and pinned to the bottom center of the carriage stiffener weighs 8.1 pounds.

The carriage platform has a flat mounting surface that is 30 7/8 inches long by 18 inches wide. Test specimens are secured to the carriage platform using a suitable combination of bolt holes with both bolt hole circles having eight bolt holes. The small circle is 8 inches in diameter, and the large circle is 16 inches in diameter. Four additional bolt holes are located at the corners of an 11 x 19 7/8-inch rectangle. All bolt holes utilize 3/8-24UNF x 11/16-inch inserts.

The carriage brakes are located in pairs on opposite sides of each 3-inch-diameter rail column. Brake-liner material is 1.50-inch-diameter phenolic contoured to the 3-inch-diameter column and pressed into the brake piston. To assure equal pressure on each of the four brake pistons, the brakes are pressurized from a common valve and branch line. A single flexible high-pressure hose 16 feet in length travels with the carriage during the impact and deceleration event. Brake pressure is set manually prior to the impact event. Minimum brake pressure is dictated by the pressure necessary to prevent the carriage and its test specimen from falling downward following the completion of the upward travel of the carriage and specimen. A brake pressure of 75 psig is sufficient to decelerate and hold the carriage assembly without a test specimen. A deceleration of 3.5 G is the minimum deceleration that has been experienced during testing. Maximum brake pressure is dictated by the pressure necessary to stop the carriage and its test specimen in the rail length remaining after the acceleration phase is completed. Using the HY-6601 profile with the 20-foot rail system results in an approximate net rail length of 152 inches in which to decelerate the carriage. A test with the HY-6601 profile to 163.5 G peak and a maximum velocity of 72.2 feet/second using a 200-psig brake pressure resulted in a 104-inch deceleration displacement at an average of 9.3 G deceleration.

Initial tests at low acceleration levels (5 to 12 G) revealed that the acceleration-time profile included a vibration with a frequency of 55 hertz. Two mechanical considerations were suspect: (1) the thrust column cap was not centered against the bottom of the carriage, and (2) the accelerated movement of

TABLE 2

DEMONSTRATED PERFORMANCE

	A	B	C	D	E	F	G	H	I	J	K
Configuration, HYGE No.	6407	6407	6407	6136	6136	6136	6136	6601	6601	6601	6134
Acceleration $\pm G_z$ (G)	12.18	105.36	128.57	7.14	26.53	13.66	74.26	4.91	163.46	119.22	113.94
Duration (MSec)	53.55	18.40	17.84	114.00	74.21	87.62	55.39	92.40	21.67	25.45	24.44
Velocity, Max (ft/Sec)	15.54	49.31	54.68	16.63	39.41	23.99	58.51	9.24	72.15	61.51	57.57
Displacement, Acc (in)	4.47	4.85	4.92	12.81	18.61	13.75	11.63	5.59	3.37	3.49	3.10
Thrust, Max Possible (LBF)	3534	29635	28950	2686	8718	2686	20279	2686	34730	23169	23169
Force, at Peak $G_z$ (LBF)	2552	21345	19770	1944	7222	2067	11365	1245	21333	15559	14904
Energy (ft-Lb)	1038	7936	7412	2077	7961	1932	9227	739	11190	3202	7229
Weight, Test Package (Lb)	40.26	40.26	0	118.85	118.85	0	0	5.0	0	0	0
Weight, Total Acc (Lb)	209.54	202.59	153.77	272.23	272.23	151.33	159.78	253.6	130.51	130.51	130.31
Wave Form*	Trap	Trap	Trap	Sine	Sine	Sine	Trap	Sine	Sine	Sine	Sine
Acc Metering Pin	261812	261312	261812	77-C-01	77-C-01	77-C-01	266510	77-C-01	77-C-01	77-C-01	77-C-01
Dec Metering Pin	262141	262141	262141	-	-	-	-	-	-	-	-
Load Pressure (PSIG)	150	1250	1200	120	360	120	340	120	1440	960	960
Set Pressure (PSIG)	30	227	200	30	60	30	140	30	240	160	160
Fluid (liters)	2.2	2.2	2.2	1.0	1.0	1.0	4.8	0.2	0.2	0.2	0.2
Deceleration $-G_z$ (g)	4.1	4.5	6.3	3.6	3.8	4.5	6.8	3.8	9.3	7.6	7.4

\*Sine = Half Sine  
Trap = Trapezoid

the carriage was coupled to a side-to-side (Y-axis) movement of the support tubes and the lower bearings/bearing retainers. The contact eccentricity was due to the impracticality of assuring a "flat" contact between the cap and carriage. Data from the previous facility installation indicated a similar situation had existed, and several attempts were made to correct it using elastomers as an interface between the cap and carriage. The cap surface was remachined, but contact was not improved. A 20-mil flat depression was machined into the top surface of the cap and then filled with molten lead. The lead mound was then machined flat to within 10 mil of the top edge of the depression. The area of contact between cap and carriage was greatly improved by this method. A temporary cross brace was also installed which pinned the bottom end of the support tubes to the bottom center of the carriage. These modifications proved to be effective in eliminating the 55-hertz vibration. Therefore, a permanent cross brace (Figure 8) has been used for all subsequent tests below 20 G acceleration.

### Rail System

The Type HY-6004 rail system (1e) includes the one-inch-thick foundation plate, two each box support legs with foot assembly, top cross beam assembly, and two each three-inch-diameter rail columns. The overall system height is 20 feet.

The foundation anchor bolts were located using a template during the pouring of the foundation. After the foundation was cured, the template was removed. The plate was positioned around the anchor bolts and leveled with a precision level. The air spaces beneath the plate were eliminated by grouting. The rail system components were assembled and raised into the upright position, all nuts and washers were hand tightened, the top cross beam was removed, and the carriage assembly was lowered over the ends of the two rail columns. The beam was then reassembled and the entire system, with carriage, was secured. The bottom end of each rail column has a captive base nut constrained by a roll pin, a base hub, and the counterbored bottom face of the foot assembly. The carriage was used as a spacer between rail columns during final assembly.

The original hoist eyebolt was removed in favor of a locally installed overhead 4:1 rope hoist with self-locking action. Inspection tools have been fabricated to check column alignment. The rail columns are parallel to less than 10 mils. Lubricants and cleaning solutions are not permitted on the surface of the rail columns.

### Performance

The performance of the vertical impact facility, as determined by tests that were completed through February 1979, is outlined in Table 2. The values are intended as a guide only. Actual performance limits will depend upon the pulse shape being utilized and the dynamics of the test article. The maximum acceleration, maximum velocity and maximum acceleration displacement values that are shown cannot be achieved simultaneously.

Columns A and B represent the minimum/maximum range of tests for the HY-6407 configuration with a test-package weight of 40.26 pounds. Column C demonstrates the effect of removal of the test package. Higher acceleration levels and maximum velocity are achieved at somewhat reduced operating pressures. Columns D, E, F, and G present the minimum/maximum range of tests for the HY-6136 configuration with extremes in test-package weight between D-E and F-G. Note the identical operating pressures for columns D and F along with the difference in acceleration values attributable to the test-package weights. Columns H and I represent the minimum/maximum range of tests for the HY-6601 configuration. Columns J and K display the difference between HY-6601 and HY-6134; two configurations are identical except for the load chamber volume.

The three basic pulse shapes produced by the vertical impact facility are the half sine, trapezoidal (or square), and the sawtooth. These shapes are produced by using the appropriate metering pins in combination with the required number and types of orifices. The waveforms are variations dependent on numerous variables, such as pressures. The trapezoidal waveform normally has a rate of onset and a plateau duration time (3) greater than the half sine for like operating parameters. The trapezoidal rate of decay is greatly affected by whether a deceleration metering pin and orifice are installed. At the present time, six acceleration and two deceleration metering pins are available. Please see figures 5 and 6.

The acceleration-time parameters for a selected accelerator assembly and a selected metering pin resulted in the following statistical determinants:

Peak G	
Mean ( $\bar{X}$ ) = 31.74	Standard deviation (S) = 1.11
Calculated Total Time (msec)	
Mean ( $\bar{X}$ ) = 46.08	Standard deviation (S) = 0.91
Sample Size (N) = 8	

For:

Vertical Actuator Assembly . . . . .	.6601
Acceleration Metering Pin . . . . .	.7788I-C-01
Load Pressure (psig) . . . . .	.240
Set Pressure (psig) . . . . .	.40
Weight, Total Acceleration (lb) . . . . .	.139

Support Elements

The vertical impact facility requires a nitrogen supply for operation. The water-pumped nitrogen supply system consists of two separate manifolds, each with three attachments for type 1A cylinders and two-stage regulators with suitable delivery pressure range and gauges. The high-pressure supply is connected to the load pressure service only. The low-pressure supply is connected to the set pressure, brake pressure, and trigger pressure services. This

configuration assures that the high-pressure nitrogen supply will not be used for the low-pressure system.

Three types of hardware are incorporated into the pneumatic distribution lines to assure safety and protect gauges. The manufacturer has incorporated an interlock safety valve which prevents pressurization of the load chamber until after the brakes are pressurized (1f). The valve permits some adjustment of the minimum brake pressure necessary to open the load pressure line to the load chamber. Four pressure snubbers have been installed within the console to protect gauge mechanisms from pressure surges. A surge chamber/oil trap has been installed in the set pressure line. This trap is used to prevent hydraulic fluid from surging back through the set pressure line during the dynamic event, thereby protecting the set pressure gauges and lines within the control console.

Three additional support items have been installed to improve area safety and assist area operations:

(1) two pieces of 2 x 2-inch chain link mesh fence (the pattern of one layer is positioned at 90 degrees to that of the second layer). The close proximity of operating personnel to the vertical impact facility requires that overhead protection be provided. Tension bands and bars fasten the fence to the rail and post frame. The center of the double fence is capable of an eight-inch deflection. Operators are required to remain under this protective screen during operations initiated with the filling of the brake pressure.

(2) two sleeved wooden platforms and add-on steps on each side of the vertical impact facility. This combination puts the carriage platform just below the standing operator's elbow for three of the four possible assembled heights of the impact facility.

(3) a 4:1 rope hoist anchored to the roof beam above the vertical impact facility. The hoist permits removal of the top cross beam, the carriage assembly, and the lifting of test specimens. The hoist has a self-locking and swivel action, with a safety latch on the hook. All loads may be lowered to floor level.

#### PROGRAM PLANNING

The investigator attempting to establish program parameters must necessarily consider both his theoretical objectives and the practical capabilities of the facility. Specific programs may require modification of existing equipment or the design and manufacture of new components, principally metering pins.

#### Theoretical Considerations

Elements to be considered include:

1. Wave (curve) form desired.
2. Specimen weight.
3. Peak dynamic force (thrust).
4. Deceleration G vs displacement.
5. Tentative choice of values and priorities for peak acceleration, time duration, final (peak) velocity, and displacement during the acceleration event.

The three prominent waveforms normally utilized are:

1. Triangle
2. Half sine
3. Square wave

These three waveforms are first approximations, permitting the investigator to weigh the values and priorities assigned to the physical test parameters. Formula coefficients for the respective curves are adjusted to convert acceleration to G, displacement from feet to inches. Where:

$$\begin{aligned} \text{Peak Acceleration} &= A = g \cdot G = \text{Acceleration (ft/sec}^2\text{)} \\ g &= 32.17 \text{ acceleration due to gravity (ft/sec}^2\text{)} \\ G &= A/32.17 \text{ (nondimensional)} \end{aligned}$$

$$\text{Final Velocity} = V \text{ (ft/sec)}$$

$$\begin{aligned} \text{Event Displacement} &= S = s/12 \text{ (feet)} \\ s &= 12 \cdot S \text{ (inches)} \end{aligned}$$

$$\begin{aligned} \text{Total Time} &= T = t/1000 \text{ (seconds)} \\ &= t = 1000 \cdot T \text{ (milliseconds)} \end{aligned}$$

$$V = f(A, T) = C1 \cdot A \cdot T$$

$$V = f(G, t) = C11 \cdot G \cdot t$$

$$\begin{aligned} S &= f(V, T) = C2 \cdot V \cdot T \\ &= C1 \cdot C2 \cdot A \cdot T^2 \end{aligned}$$

$$\begin{aligned} s &= f(V, t) = C22 \cdot V \cdot t \\ &= C11 \cdot C22 \cdot G \cdot t^2 \end{aligned}$$

Curve Form	C1	C11	C2	C22
Triangle	0.5	0.0161	0.5	0.006
Half sine	2/PI	0.0205	0.5	0.006
Square wave	1.0	0.0322	0.5	0.006

Estimates of the physical test parameters may also be accomplished using a nomograph (1a).

The three principle waveform descriptions are modified to reflect practical waveforms and to insure accuracy in verbal description.

#### Isosceles Triangle:

1. Triangle, with rate of onset (G/second) greater than rate of decay (G/second).
2. Triangle, with rate of onset less than rate of decay.
3. Initial peak sawtooth.
4. Terminal peak sawtooth.

#### Half Sine:

1. One-quarter sine + one-quarter cosine.
2. One-half haversine + one-quarter cosine.

#### Square Wave:

1. Trapezoidal, with a triangular element at each end.
2. Trapezoidal, with a one-half haversine at the leading end and a one-quarter cosine element at the trailing end.

These more detailed waveforms permit variation in the time allotted for each section of the waveform, thereby altering the rate of onset and rate of decay. All of the above waveforms may be reduced to algebraic-trigonometric expressions and programmed by the computer for detailed analysis and curve plots.

The total accelerated weight is determined by adding the weight of the test package and its tie-down hardware to the known weight of the dynamic parts of the facility. The weight of the dynamic parts requires a tentative selection of both the length of thrust column and the quantity of hydraulic fluid to be used. The peak dynamic force of the system is the product of peak G and total

# 6 - INCH HYGE VERTICAL ACTUATOR THEORETICAL ENERGY ENVELOPES THRUST VS DISPLACEMENT

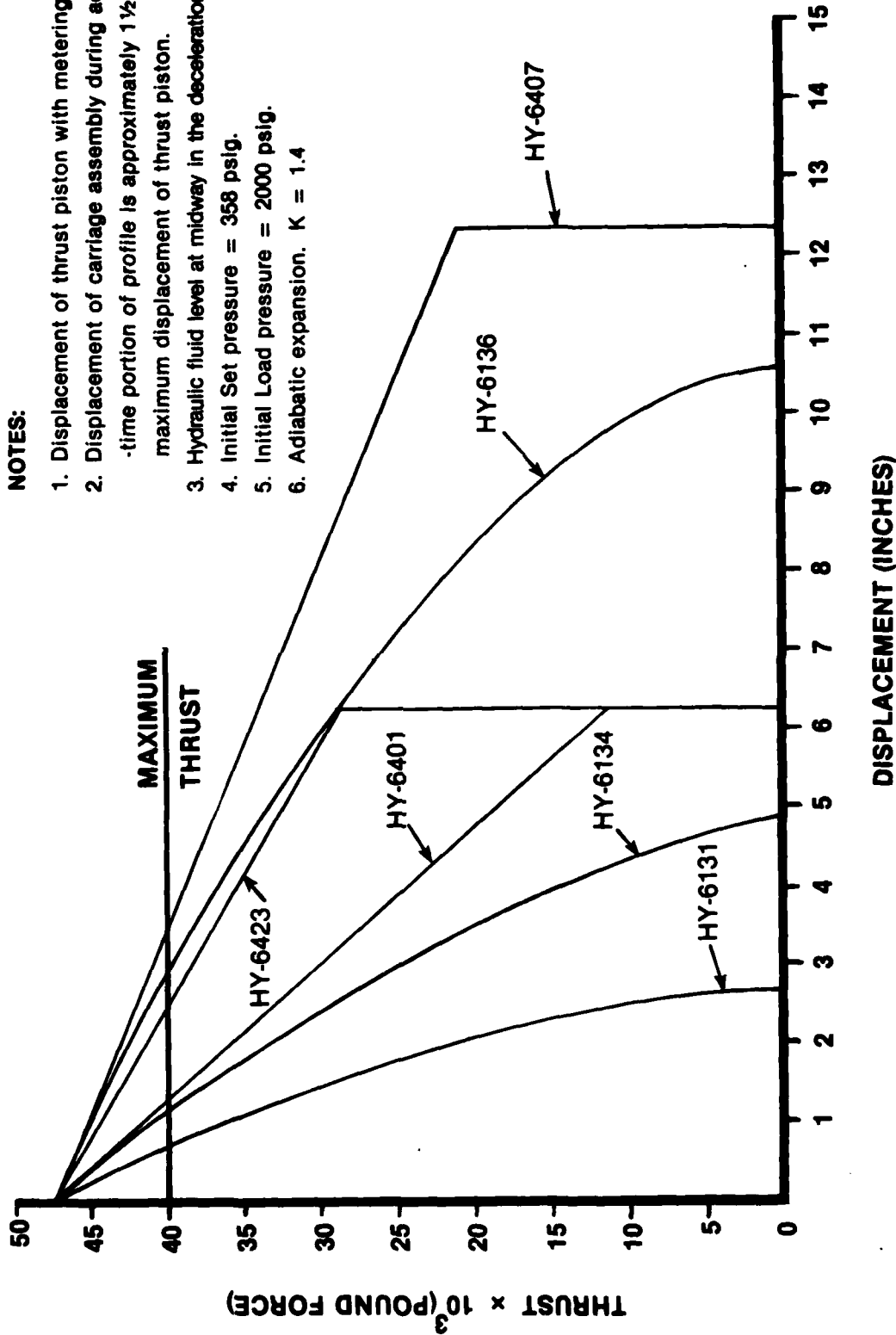

FIGURE 9. THEORETICAL THRUST-DISPLACEMENT CURVE (REF 1C).

accelerated weight. This must be increased by the addition of the force lost internally, estimated from the auxiliary correction factor curve supplied with the nomograph. This correction may be approximated at between 5 and 15 percent of the peak force. The Theoretical Thrust-Displacement Curves (Figure 9) (1c) are consulted to determine which actuator assembly configurations meet the requirements of the program.

The deceleration displacement cannot exceed the difference between the height of the rail system and the height of the test specimen at the end of the acceleration event. This displacement may be calculated:

$$V^2 = 2 A S$$

or

$$V^2 = 2 * g * G * S$$

where:

$$\text{Braking Deceleration} = A = g * G \text{ (ft/sec}^2\text{)}$$

### Practical Considerations

The computer used to perform the calculations in this report produces several outputs for each test performed. One of these is a catalog (not included) of summary test results which documents 32 parameters from each test. Each page of this catalog tabulates nine successive tests. The catalog pages may be quickly scanned for the desired parameters. The computer may also be programmed to identify specific tests versus selected individual parameters within designated minimum/maximum limits.

If the desired match of resultant test values cannot be found in the catalog, the actuator operating parameters which affect the acceleration profile may be altered. These operating parameters are:

- Pin shape(s)
- Total acceleration weight
- Set pressure
- Load pressure
- Ratio, Load/Set pressure
- Set volume length
- Load volume length
- Brake pressure

<u>Parameter Change</u>	<u>Resultant Effects</u>
Change from half sine to trapezoidal metering pin(s)	No change in G Decrease velocity Decrease total time
Increase total acceleration weight	Decrease G Decrease velocity Increase total time

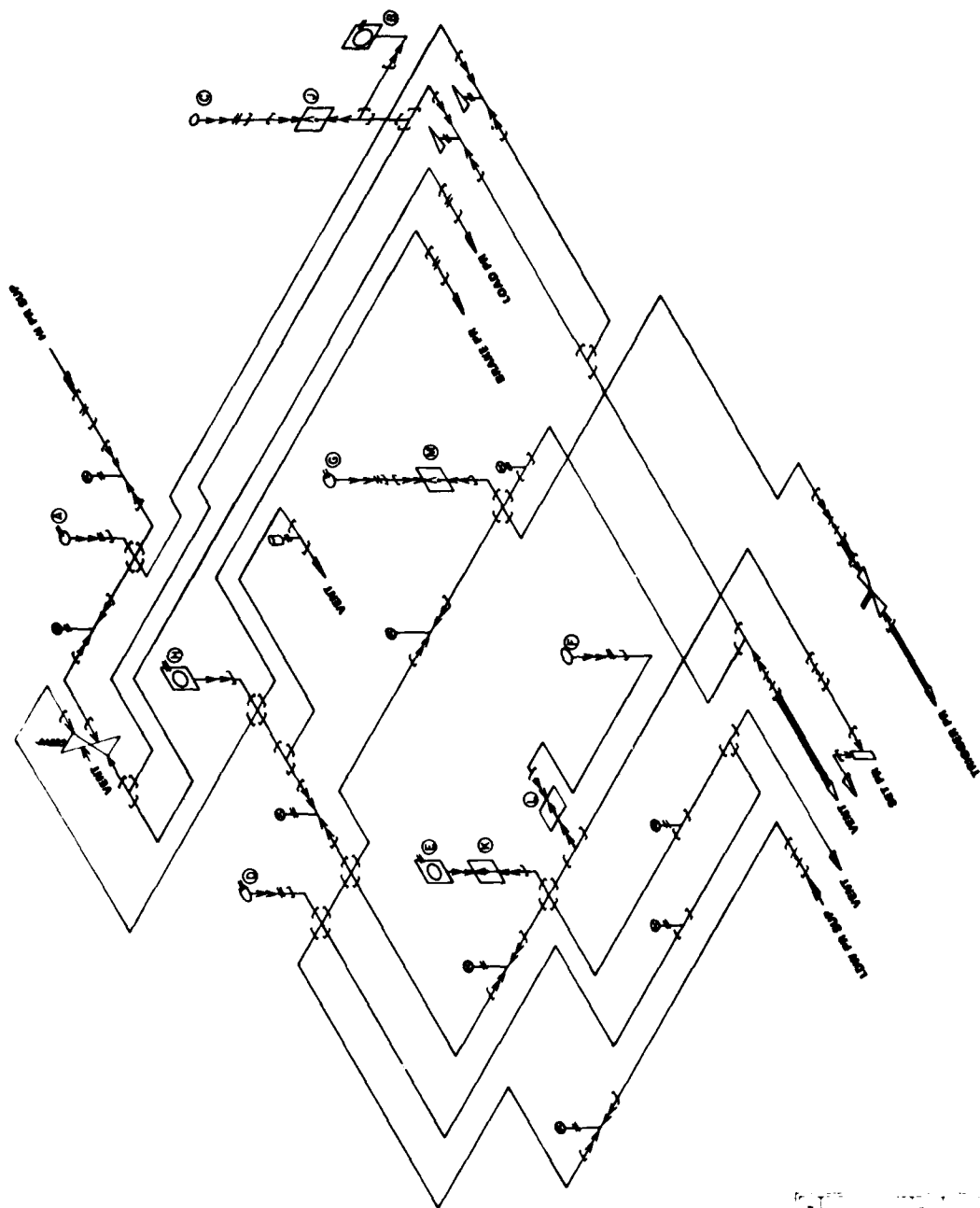

**LEGEND**

- GAS, 2" OR 3"
- GAS, 4"
- PRESSURE GAUGING
- SHUT-OFF VALVE
- BALL VALVE, 1/2 TURN
- VENTURI VALVE
- INTERLOCK SAFETY VALVE
- SOLENOID VALVE
- 1" O.D. TUBE
- 3/8" O.D. TUBE
- CONSOLE PANEL OR BULKHEAD
- FLANGELESS FITTING
- PIPE UNION
- SURGE CHAMBER

MATERIALS LIST	
ITEM NO.	DESCRIPTION
1	1" O.D. TUBE
2	3/8" O.D. TUBE
3	SOLENOID VALVE
4	INTERLOCK SAFETY VALVE
5	BALL VALVE, 1/2 TURN
6	SHUT-OFF VALVE
7	VENTURI VALVE
8	CONSOLE PANEL OR BULKHEAD
9	FLANGELESS FITTING
10	PIPE UNION
11	SURGE CHAMBER

FIGURE 10. PNEUMATIC DIAGRAM.

<u>Parameter Change</u>	<u>Resultant Effects</u>
Increase load/ set pressures	Increase G Increase velocity Decrease total time
Increase load/set pressure ratio	Increase G Increase velocity Decrease total time
Increase set volume length	Increase G Increase velocity Increase total time
Increase load volume	Increase G Increase velocity Increase total time
Increase brake pressure	No significant change in parameters

## INSTRUMENTATION SYSTEM

### Pressure Measurements

This section describes the system measurements made to describe the impact profile and monitor the vertical actuator pressures. The pneumatic system diagram (Figure 10) locates the various components monitoring and controlling the operating pressures between the two nitrogen supply manifolds and the several actuator chambers and carriage brakes.

Four pressure measurements must be monitored on the vertical impact facility to insure accurate pulses and repeatability. These measurements are load, set, brake, and trigger pressures. The load pressure is measured with two gauges. One gauge, a 0-3000 psi,  $\frac{1}{2}$ -inch-diameter ACCO helicoid type, is used to measure pressures over 100 psig. The second gauge, a 0-200 psi,  $\frac{1}{2}$ -inch-diameter Matheson gauge protected by a pressure snubber, measures pressures under 150 psig. The set pressure is also measured with two gauges. One gauge is a 0-1000 psi,  $\frac{1}{2}$ -inch-diameter ACCO helicoid type to measure pressures over 60 psig, also protected by a pressure snubber. The second set pressure gauge, a 0-100 psi,  $\frac{1}{2}$ -inch-diameter Matheson gauge protected by a pressure snubber, measures pressures under 60 psig. The trigger pressure is measured with a 0-1000 psi, 2-inch-diameter Airco gauge protected by a pressure snubber. The brake pressure is measured by a 0-500 psi,  $\frac{1}{2}$ -inch-diameter ACCO helicoid gauge. Use of dual load and set pressure gauges permits the accurate monitoring of the respective pressures during the venting procedure at low pressures.

## Inertial Measurements

The instrumentation system for the majority of the AFAMRL impact test facilities is organized to use (1) the same inventory of transducers for all tests and (2) a central collection center for recording the test data. The data can be stored in a variety of modes for further processing and analysis. This section describes the instrumentation system as it serves the vertical impact facility. Data must be acquired to measure the impact environment produced and the test-article responses, and to operate the firing controls. Three piezo-resistive accelerometers are mounted on the carriage to monitor the +Z axis (vertical), +Y axis (side to side between rail columns), and +X axis (front to rear). An accelerometer is also mounted on the cap of the thrust column to monitor +Z axis accelerations.

Accelerometers used are:

+Z axis    Entran EGA 125F-500-D

+X axis    CEC 4-202-001

+Y axis    CEC 4-202-001

Thrust column Entran EGA 125F-250-D

To measure test article responses, transducers are selected from inventory as requirements become known.

The impact test facility instrumentation system is configured to handle primarily bridge type transducers. Included in this class are wire-wound strain gauge and peizo-resistive types, commonly found in transducers which measure accelerations, forces and pressures. The basic transducer channel is configured as a seven-wire system. This conditioning system allows accurate excitation voltages to be applied and calibration resistors, which compensate for line losses, to be inserted,

## Data Transmission

Transducers used to measure the impact event are individually connected to a junction box located below the platform of the carriage. This junction box has nine connectors with individual shielded cables paralleled as a free-hanging cable along with a bungee snubber anchored to an overhead tie-point. These cables are terminated in a local multi-facility patch panel. A cable consisting of 19 paired, shielded cables is routed from the rear of the patch panel via a box conduit approximately 150 feet to an instrumentation console in the instrumentation room. The selected cables are then routed for signal conditioning and data processing.

## Signal Processing

The data signals pass through several stages of conditioning equipment prior to recording and display. Forty signal conditioners are available for producing the excitation voltages, inserting bridge-completion resistors, balancing bridge outputs, and installing calibration resistors. Data signals are passed through the signal conditioners to differential amplifiers where the data are amplified and filtered. The amplifier output is multiplexed using FM constant bandwidth techniques for maximum data density. The multiplexed data are stored on a 14-track analog tape recorder for playback and data processing. Data used in the operation of this facility are filtered at 3000 hertz.

## Recorder

The 14-track analog tape recorder is an Ampex FR-2000A multiband instrumentation recorder having a recording speed of 60 inches per second, a bandwidth of 300-3000 hertz (+3 dB), and an S/N (RMS Signal to RMS Noise) of 37 dB.

## Data Display

A Honeywell Model 1858 Cathode Ray Tube Visicorder is used to display data to permit quick look and data verification. The visicorder uses light from a fiber-optic cathode ray tube to record up to 18 simultaneous data channels on moving photosensitive paper. A model 1883-MPD medium performance differential plug-in module is used in each of the 18 data channels. The visicorder specifications are:

1MV-300V input sensitivity to 300V common mode

Time-interval marking

Auto-linearized for increased data accuracy

Numbered track identification

Speed 0.1 to 120 inches per second

Differential input

Frequency response--DC-5000 hertz

+0, -0.5% maximum error DC-1000 hertz

+0, -1.3% maximum error DC-2000 hertz

+0, -3% maximum error DC-3000 hertz

+0, -8% maximum error DC-5000 hertz

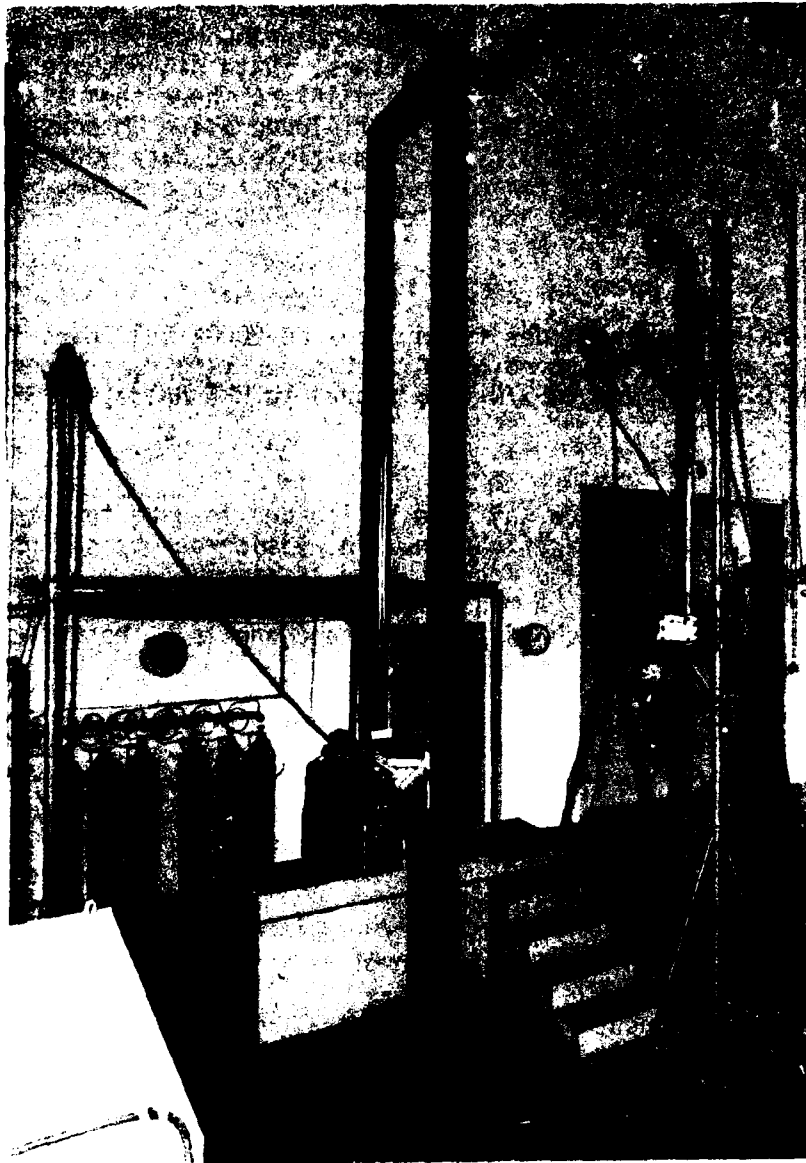

FIGURE 11. PHOTOGRAPHIC CAMERAS AND HIGH INTENSITY LIGHTING.

Quick-look data may be obtained in either real-time data acquisition prior to multiplexing or playback from the Ampex data recorder.

### Timing Control

A timing control system provides time correlation of the electronic and photometric data. The recorded time reference is 100 PPS established by an Astrodata Model 5400 time code translator/generator. The reference time pulse train commences at  $t=0$  and is recorded simultaneously on a single-tape track and on photographic film. Recorded on the same track and prior to the timing pulse train ( $t=0$ ) is a group of pulses generated at each calibration step. These pulses are used to activate automatically the calibration sequence for the accelerometers. The leading edge of the timing pulse, which commences at  $t=0$ , starts the visicorder for the data display of the test in progress. A delayed reference mark is initiated and recorded on a single-tape track to provide a common reference for data processing and photo data reduction. The delayed reference mark is a preset delay of 10-millisecond increments commencing at  $t=0$ . The delay also eliminates the processing of unneeded data prior to first motion of the event. It takes approximately 30 milliseconds after  $t=0$  for the trigger pressure to start the acceleration event.

### PHOTOGRAPHIC COVERAGE

Figure 11 illustrates the relative locations of photographic cameras and high-intensity lighting system. Three Milliken 16mm cameras and seven Berkey Cine-Queen Model 112-0356 lamps cover the acceleration and terminal locations of the impact event. Film speed is limited to 500 frames per second. (Higher speed cameras can be adapted for use, if required.) Timing pips are placed on the film using an L. M. Dearing Model 2-3-3R Light Emitting Diode Driver. The pip frequency is controlled by the timing control source. The timing source is selectable between an Astrodata Model 5400 Time Code Translator/Generator and the AC line frequency. Power for the lighting is provided by one Berkey Colortran Converter.

The Camera, Lighting, and Timing Station provides the comparator controls for operating the cameras, high-intensity lights, and the timing-synchronization system. The upper section of the station contains the camera LED drive circuit. The lower section contains a countdown clock display, comparator thumbwheel switches, abort indicator, override switches, manual control switches, and a precount ready switch.

Photographic film is processed using the facilities of the Aeronautical Systems Division.

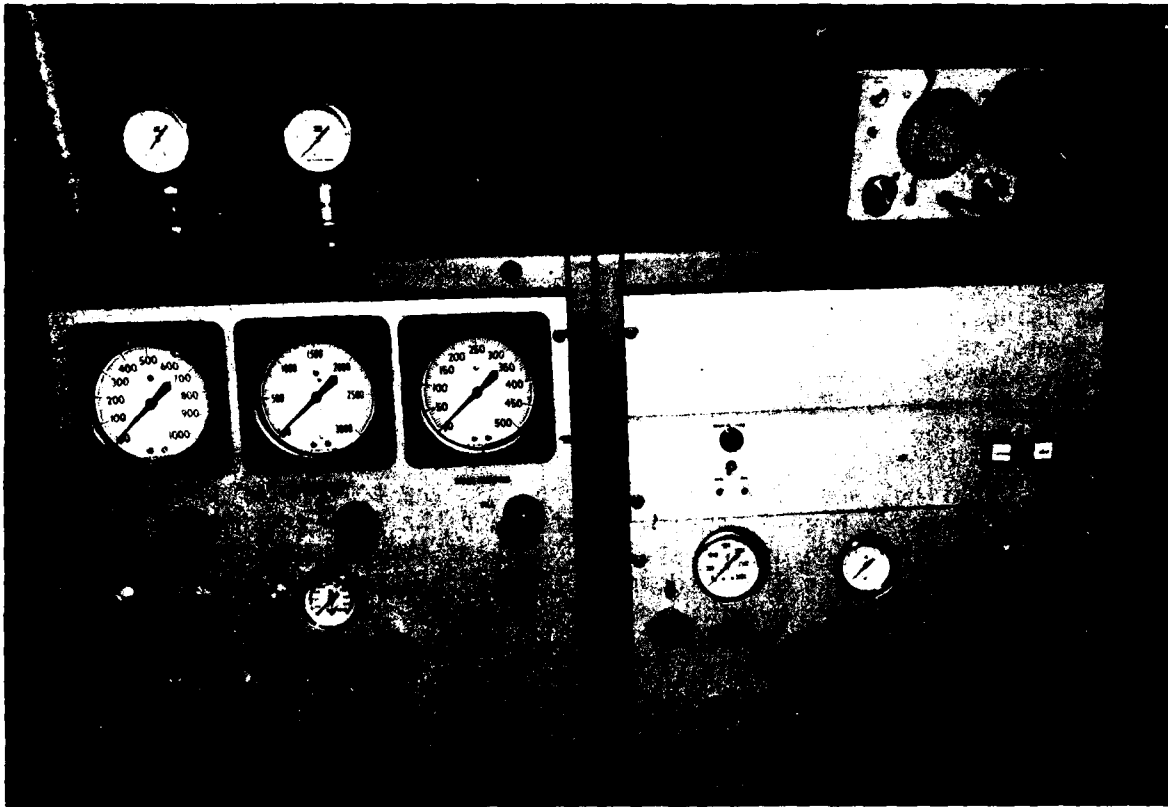

FIGURE 12. OPERATION AND SAFETY CONSOLE.

## OPERATION AND SAFETY SYSTEMS

### Automatic Control

The operation and safety systems are a group of interrelated functions designed to meet the requirements of controlled impact testing on the vertical impact facility. There are five separate functions in the system.

1. Operation, performed by the facility operator,
2. Safety, performed by the safety monitor,
3. Master clock and instrumentation,
4. Data analysis,
5. Camera, lighting, and timing.

Operation and safety are the two functions required for a manually controlled test. The final three functions are adequately discussed in other sections of this report and in Reference 4.

System functions may be outlined in terms of who performs the specific function. The operating instructions found in Appendix I also document which individual performs the system-sequenced operations. The checklists actually used during the conduct of a test are derived from the operating instructions.

The Operation and Safety Console is illustrated in Figure 12. The console consists of two chassis, 50 inches high, with sloping front panels. During the testing phase, the facility operator is positioned at the left chassis; the safety monitor is positioned at the right chassis. The panel layout and operating instructions are organized to assure that the two personnel do not have "cross-over" actions once the filling of the set pressure is initiated.

#### 1. Facility Operator's Station

The facility operator has the responsibility for the implementation of the test requirements assigned by the test conductor and assuring proper set-up and operation of the equipment. He is also responsible for the operation and performance of the mechanical equipment, for recording and documenting performance, and for initiating corrective action to maintain the system in a ready condition.

The facility operator must concentrate on the pressure gauges and valves in the left chassis (facility operator's station) of the console during the critical portions of a test. The pressures used are controlled solely by the facility operator. Induced pressures have no minimum/maximum controls or warning devices, nor are they recorded. An intimate knowledge of the pneumatic

circuitry of Figure 10 is essential. During the final countdown of a test, the facility operator must switch on (up) and hold his detent FIRE ENABLE switch to complete the test-firing circuitry.

The four test pressures are selected by the test conductor. The facility operator must fill the pressures in the order of set, brake, load, and trigger pressure. The set pressure may cause the orifice seal O-ring to compress slightly. Therefore, the carriage must be checked to insure that the carriage is in contact with the cap of the thrust piston ram. The brake pressure is filled next in order to operate the brake interlock slider valve. Only then can the facility operator fill the load pressure cylinder(s). Either during the filling of the load pressure or shortly before the start of the filling of the trigger pressure, the facility operator may pause and listen. Should there be critical internal bypass leakage around critical seals, this leakage may be audible (nitrogen escaping through the 0.040-inch vent in the cap on the trigger pressure entrance port). In this event, shut down quickly and vent the load pressure to prevent an autofire. The most likely cause of this audible leakage is load pressure leaking by the orifice O-ring seal into the trigger pressure chamber.

## 2. Safety Monitor's Station

The safety monitor has the responsibility for the implementation of safety requirements, assuring proper set-up and monitoring of safety conditions. He is responsible to see that only authorized personnel are in the test area and to correct any violation of safety. Because the large majority of functional operations depend on the human operators, several critical functions are assigned to both operators. However, the safety monitor has the principal responsibility for all safety functions. This includes assuring that the carriage assembly is physically against the top of the thrust column cap prior to the impact event, and checking that the carriage assembly and test package are cleared of loose hardware. The safety monitor also assists the facility operator with items of pre-test start-up and post-test shutdown.

The safety monitor communicates with the remote instrumentation operator, thereby permitting the facility operator to concentrate on the pressure gauges and valves. The safety monitor also performs the electrical/electronic switching, including switching ON the facility patch board cabinet. Each operator must switch on (up) and hold his respective detent FIRE ENABLE switch to complete the test-firing circuitry.

### Manual Test Mode

The manual test mode is used when the automatic test mode is not desired. Use of the manual mode makes it extremely difficult to obtain instrumented test results. The start of the event becomes so uncertain that the time-based data would be unnecessarily long.

The manual mode is used under two conditions: (1) the first test of the day, usually performed to exercise the facility (Instrumented results are not required, the test specimen may not be mounted on the carriage, and load and set pressures may be very low compared to pressures required for the instrumented tests.) and (2) when an autofire test is desired.

The abbreviated test sequence is:

1. Facility operator - Fill to selected set, brake, load, and trigger pressures, in sequence.
2. Safety monitor - Switch the firing mode to MANUAL.
3. Both operators - Switch on (up) and hold the detent FIRE ENABLE switch.
4. Safety monitor - Push in MANUAL FIRE momentary-on switch.

### Autofire

The autofire method of testing does permit the use of pressure ratios (load/set pressures) higher than those normally employed. Also, it is advisable prior to the start of a sequence of tests to determine empirical autofire pressure ratios over the range of anticipated set pressures for the specific assembly being utilized. As reported earlier, the autofire pressure ratio has been noted as low as 6.2. The necessary test sequence is outlined in MAINTENANCE.

## DATA REDUCTION SYSTEMS

### Requirements

The purpose of data reduction is to reduce and process collected data to derive specific characteristics of interest in each test. This may require either quick data reduction to allow decisions to be made on test progression, or complex evaluations such as vector summations. The data reduction systems utilized at the impact test facilities provide capabilities in both areas.

### Quick Look

Quick-look data are required on programs to assure that the desired data are being collected and that expected trends are being achieved. This usually involves examination of analog waveforms for peak G attained, and acceleration pulse duration. The Honeywell visicorder is used to record these analog traces from a test. The traces may be done real time with the test or by playback immediately after the test is completed. The visicorder record can be produced within ten minutes after the test.

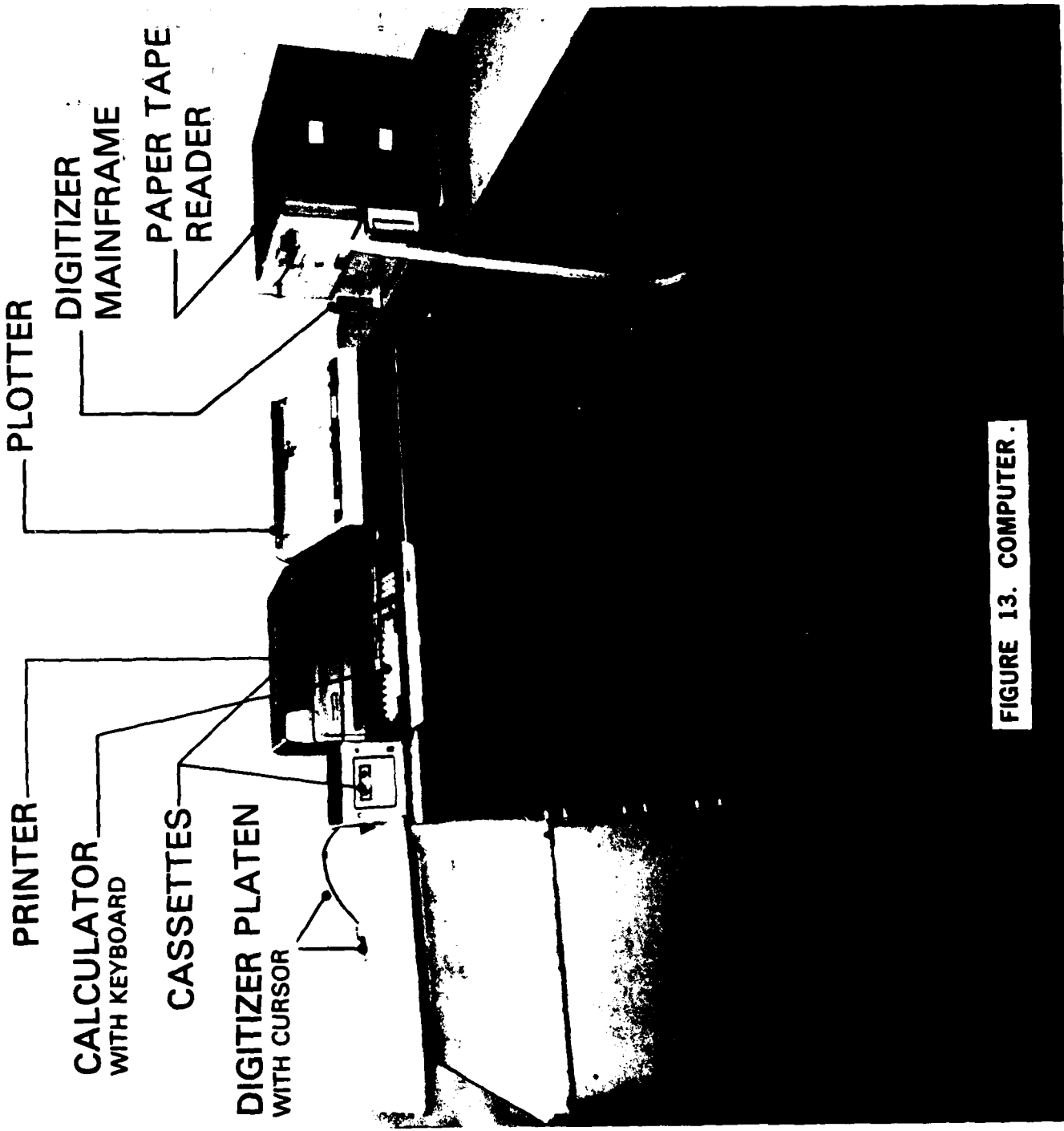

FIGURE 13. COMPUTER.

## Data Processing

Detailed examination of special-purpose integrals requires lengthy post-test processing. The first sequence of events is to process analog data directly from the tape recorder to produce digitized punch paper tape with a corresponding tabulated printout. This assembly of equipment includes a Time/Data 1923/30 Time Series Analysis System with a DEC PDP 11/15 computer and a Teletype.

A Hewlett-Packard 9830 computer system (Figure 13) is used for the second sequence of data processing. It uses the BASIC programming language, and memory size is 7904 words. The assembled equipment includes an alphanumeric keyboard, printer, multicolored plotter, optical paper tape reader, digitizer mainframe and platen with cursor, and two cassette transports for storage of programs and data.

The optical punched paper tape reader reads-in the acceleration-time data. The data are integrated to provide both the velocity and displacement of the specimen carriage, including the early portion of the deceleration (braking) stage. A multitude of test parameters are entered via the keyboard, including string data with alpha characters. Program routines are used to select specific points of interest within the data (i.e., time and displacement at peak G) and to calculate secondary data (i.e.,  $\mu$ , braking coefficient of friction). An extensive routine then calculates the rate of onset (G/second) and rate of decay for the acceleration-time profile per the outline of MIL-S-9479B (USAF) (5). Output is in the form of both printed data via the printer and graphs utilizing the plotter. A sort routine is used to select 32 resultant test parameters and to file automatically the parameter values in the locally maintained catalog of test results. This catalog is stored on cassette and may be retabulated by a separate program. The data from each test found in several programmed matrices may be stored on cassette files, if desired.

The computer is also used to perform the design of required acceleration metering pins. The program has been successfully used for both the impulse accelerator (24" HYGE) (4) and the vertical impact facility.

## MAINTENANCE

The locally maintained vertical impact facility manual contains a section entitled maintenance instructions. These instructions are continuously updated as experience dictates or as judgment suggests. The instructions may also be temporarily altered to provide a "best fit" for a specific test program or a vertical actuator assembly configuration. The instructions include supplementary documentation, safety precautions, equipment required, maintenance performance intervals, and procedures.

The supplementary documentation is derived in part from Reference 1. Included are the manufacturer's installation, maintenance and operating manuals, along with drawings and parts lists. Also incorporated are titles of operation and maintenance manuals of several supportive equipment facilities. Local engineering drawings of modifications and additions are also catalogued.

The listing of required equipment includes the hydraulic fluid utilized, reference to all O-rings required, special inspection tools, miscellaneous expendable supplies, and sundry maintenance tools.

The maintenance performance intervals are specified in one of three manners: (1) a thorough initial checkout of the system each time the mechanical profile is altered for a new program, (2) selected maintenance at the conclusion of a pre-selected number of tests, or (3) pre-selected time intervals varying from one month to one year.

The maintenance procedures include the vertical actuator assemblies, specimen carriage, 20-foot rail system, the control console, nitrogen supplies and manifolds, area safety and security devices, and recommended performance validation tests. The maintenance items include excerpts from the manufacturer's operating and maintenance instructions integrated with local instructions derived from experience gathered from similar facilities. The conditions of dynamic and static seals, hydraulic fluid levels, the safety interlock valve operation, and the condition of teflon bearings and brake pistons are all critical and are detailed individually. Rail spacing and condition are checked periodically. The rail columns must be kept free of rust and gouges, and free (dry) of solvents and lubricants. Control console gauges are removed yearly for calibration by the Wright-Patterson Precision Measurement Equipment Laboratory (PMEL). All pneumatic lines and valves are leak checked following reinstallation of the console gauges.

Three performance validation tests are detailed.

1. Normal sequenced test, instrumented 90-day intervals and initial checkout of a new program profile. Perform a standard instrumented test per existing checklists and operating instructions.

2. AUTOFIRE test, non-instrumented, 90-day intervals and initial checkout of a new program profile. Performed following the normal sequenced test. Use carriage without a test specimen. Fill to SET PRESSURE of 50 psig. Fill to BRAKE PRESSURE of 100 psig. Then slowly increase the LOAD PRESSURE until AUTOFIRE occurs. Note and record LOAD PRESSURE. Determine and compare pressure ratio:  $\text{LOAD (ABSOLUTE) / SET (ABSOLUTE)}$ .

3. "Signature" test, instrumented. The purpose is to provide a small group of "signature" test profiles to be performed at intervals to establish a time-based history of the vertical impact facility performance. Collected comparison data may reveal changes in performance characteristics. These tests may

be performed at initial profile setup, at scheduled maintenance intervals, or just prior to disassembly of a setup. Due to the large possible selection of variables, only a few tests will be defined as a "signature" test, based upon developing test quantities.

**Signature No.1**

**HY-6601**

**Acceleration Metering Pin No. 77881-C-01**

**Deceleration Metering Pin No. - none**

**Hydraulic Fluid - 0.2 Liters**

**Weight - Carriage with instrumentation only**

**Load Pr - 480 psig**

**Set Pr - 80 psig**

**Brake Pr - 125 psig**

**Trigger Pr - 200 psig**

**Test Numbers - (Catalog all)**

A maintenance log documents disassembly and reassembly of vertical actuator configurations, changes in metering pins and hydraulic fluid levels, and other changes affecting system performance. Also logged are changes in support equipment, malfunctions and corrective action.

Electrical, electronic, and instrumentation maintenance requirements for the total impact facility are documented in Reference 4.

APPENDIX I - A

1. TITLE: 6" HYGE Vertical Impact Facility - Facility Operator's Operating Instructions.

2. PURPOSE: To establish standard operating procedures for the Facility Operator to assure proper setup and operation of the test facility equipment.

3. SCOPE: This instruction outlines in detail the functions to be performed in the different phases of operation.

4. SUPPLEMENTARY DOCUMENTATION: Reference Section 2, MAINTENANCE INSTRUCTIONS.

5. HAZARDS AND PRECAUTIONS:

5.1 All personnel working in the test area must be cautioned about the proper use of the test facility and safety measures to be taken.

5.1.1 The test facility must not be approached when Brake, Load, and/or Trigger pressures are being filled or are up to desired operational pressure.

a. Wear protective hard hat when vertical actuator is being pressurized.

b. Maintain orderly, safe work environment

c. Handle high-pressure nitrogen cylinders with extreme caution.

d. Check carriage assembly for loose bolts, tools, etc., prior to filling to selected load pressure.

e. Check that the carriage assembly is physically against the top of the thrust column.

f. Check that the brake-pressure hose, instrumentation cable, and tape measure are clear of obstructions.

6. EQUIPMENT REQUIRED:

6.1 Protective hard hat.

6.2 Nitrogen supply

6.3 Tape measure

6.4 Facility Operator's Checklist

7. GENERAL: The operating techniques and instructions outlined in this document, when used in conjunction with the supplementary documentation, provide a means of assuring consistent, reliable performance of the vertical impact facility as well as the safety of personnel.

8. RESPONSIBILITY: The facility operator is responsible for the implementation of test requirements assigned by the Test Conductor, and assuring proper setup and operation of the equipment. He is responsible for the operation and overall performance of the mechanical equipment, and for recording and documenting performance. He is responsible for initiating corrective action to maintain the system in a ready condition.

9. DETAILED PROCEDURES: These procedures are in five sections: 9.1 Facility Setup, 9.2 Pre-Test, 9.3 Test, 9.4 Post-Firing, and 9.5 Facility Shutdown.

#### 9.1 Facility Setup.

9.1.1 The test conductor will advise all test personnel of the time, nature, and number of tests.

9.1.2 Replace nitrogen cylinders with gas pressures less than 200-300 psig above their respective desired SUPPLY pressures. See 7.5 Nitrogen Supplies of Maintenance Instructions.

9.1.3 Assemble required HYGE base, cylinders, orifice plates, metering pins, and thrust column.

9.1.4 Meter required hydraulic fluid. Record quantity and height. Then assemble required cover.

9.1.5 Check all pneumatic lines, including both SUPPLY manifolds, for leaks. Check all flexible hoses and their fittings. See 7.4.1 Control Console of Maintenance Instructions.

9.1.6 Complete Configuration section of 6" HYGE Test Log. Coordinate with test conductor. Complete any remaining entries jointly with test conductor.

#### 9.2 Pre-Test:

9.2.1 Position the acceleration metering pin with assembled components against the acceleration orifice plate.

9.2.2 Dip stick and record hydraulic fluid height. Cap fitting.

9.2.3 Release carriage rail clamps.

9.2.4 Lower the carriage assembly to the top of the thrust column.

9.2.5 Secure the test package.

9.2.6 Secure cloth tape measure to carriage clip. Pull out sufficient length of tape. Note and record pre-test reference height.

9.2.7 Complete pre-test portion of 6" HYGE Test Log including Set, Brake, Load, and Trigger pressures.

9.2.8 Switch console 120V and intercom POWER to ON.

9.2.9 Begin to wear hard hat.

9.2.10 Advise all test personnel of readiness to pressurize system.

9.2.11 Open low-pressure manifold cylinders, regulator and supply valve; set regulator delivery pressure.

9.2.12 Open high-pressure manifold cylinders, regulator and supply valves; set regulator delivery pressure.

9.2.13 Open console LOW PRESSURE and HIGH PRESSURE SUPPLY valves; readjust manifold regulators.

9.2.14 FILL to select SET PRESSURE and close valve.

9.2.15 Check to assure that the carriage assembly is physically against the top of the thrust column. Check rail clamps.

9.2.16 Clear carriage assembly and HYGE assembly of loose hardware.

9.2.17 Check that the BRAKE PRESSURE flexible hose, instrumentation cable and tape measure will be free of obstruction as they travel with the carriage assembly.

### 9.3 Test:

CAUTION: DO NOT exit from under the protective overhead screen until the post-firing phase of operations.

9.3.1 FILL to selected BRAKE PRESSURE and close valve.

9.3.2 FILL to selected LOAD PRESSURE and close valve. (Load pressure, maximum  $\leq 6 \times$  set pressure)

9.3.3 FILL to selected TRIGGER PRESSURE and close valve.

9.3.4 Check that console instrumentation panel firing mode switch is to AUTO.

9.3.5 Advise all test personnel that all pressures are up and of readiness to activate countdown START switch. Wait for all affirmative replies.

9.3.6 Instruct the Safety Monitor to activate the countdown AUTOMATIC FIRE-START switch to COUNTING.

9.3.7 Upon hearing from the Instrumentation Operator that the countdown is in progress, switch on (up) and hold the detent FIRE ENABLE switch.

#### 9.4 Post-Firing:

9.4.1 Release and cover the detent FIRE ENABLE switch.

9.4.2 Check that the carriage assembly brakes are holding adequately.

9.4.3 Record the final height of the carriage assembly.

9.4.4 VENT the LOAD PRESSURE and TRIGGER PRESSURE to return the thrust column to its initial position.

9.4.5 VENT the BRAKE PRESSURE to lower the carriage assembly and its test package to the top of the thrust column. Keep one hand on the BRAKE PRESSURE FILL valve. In the event that the carriage begins to descend too rapidly, open the FILL valve (and close the VENT valve). (The carriage will also descend rapidly if the BRAKE PRESSURE is allowed to decrease below the value necessary to activate the Safety Interlock Valve located in the console.)

9.4.6 Check that the carriage assembly is physically against the top of the thrust column.

9.4.7 Close the BRAKE, LOAD, and TRIGGER PRESSURE VENT VALVES.

9.4.8 Complete the 6" HYG E Test Log.

#### 9.5 Facility Shutdown:

9.5.1 Remove the test package, if required.

9.5.2 VENT the SET PRESSURE to zero psig. Close the SET PRESSURE<sup>4</sup> VENT valve.

9.5.3 Check both SUPPLY manifold regulator gauges to determine that each SUPPLY has a minimum of 200-300 psig above the next respective specified operational pressures. Note remaining pressure on individual bottle tags.

Close both manifold cylinders. Vent the high-pressure manifold line through the console HIGH PRESSURE SUPPLY FILL and VENT valves; close the console HIGH PRESSURE valves when venting is completed. Vent the low-pressure manifold line through the console LOW PRESSURE SUPPLY FILL and VENT valves; close the console LOW PRESSURE valves when venting is completed. Close both manifold regulators and supply valves.

9.5.4 Vent all lines indicating residual pressure in the sequence of LOAD, TRIGGER, SET, and BRAKE.

9.5.5 Inform Principal Investigator of test results and provide any additional data requested.

APPENDIX I - B

1. TITLE: 6" HYGE Vertical Impact Facility - Safety Monitor's Operating Instructions.

2. PURPOSE: To establish standard operating procedures for the Safety Monitor to assure satisfactory test area safety.

3. SCOPE: This instruction outlines in detail the functions to be performed in the different phases of operation.

4. SUPPLEMENTARY DOCUMENTATION: Reference Section 2, MAINTENANCE INSTRUCTIONS.

5. HAZARDS AND PRECAUTIONS:

5.1 All personnel working in the test area must be cautioned about the proper use of the test facility and safety measures to be taken.

5.1.1 The facility must not be approached when Brake, Load, and/or Trigger pressures are being filled or are up to desired operational pressure.

a. Wear protective hard hat when vertical actuator is being pressurized.

b. Maintain orderly, safe work environment.

c. Check carriage assembly for loose bolts, tools, etc., prior to filling to selected load pressure.

d. Check that the carriage assembly is physically against the top of the thrust column.

e. Check that the brake pressure hose, instrumentation cable, and tape measure are clear of obstructions.

6. EQUIPMENT REQUIRED:

6.1 Protective hard hats.

6.2 TEST IN PROGRESS poster.

6.3 SAFETY MONITOR'S CHECKLIST.

6.4 Perimeter stands and webbing.

7. GENERAL: The operating techniques and instructions outlined in this document, when used in conjunction with the supplementary documentation, provide a means of assuring consistent, reliable performance of the vertical impact facility as well as the safety of personnel.

8. RESPONSIBILITY: The Safety Monitor is responsible for the implementation of safety requirements, and assuring proper setup and monitoring of safety conditions. He is responsible to ensure that only authorized personnel are in the test area and to correct any violation of safety.

9. DETAILED PROCEDURES: These procedures are in four sections: 9.1 Pre-Test, 9.2 Test, 9.3 Post-Firing, and 9.4 Facility Shutdown.

9.1 Pre-Test:

9.1.1 Locate test area intercom at Safety Monitor's Station; make operational.

9.1.2 Make hard hats available.

9.1.3 Place TEST IN PROGRESS poster on personnel door in R112 between R112 and R112A. Place a physical barricade against personnel door.

9.1.4 Open south door of double-door set between R112 and R112A to permit pedestrian traffic.

9.1.5 Set up test area perimeter utilizing portable stands placed a minimum of 15 feet from the thrust column. Interconnect stands using half-inch wide yellow webbing.

9.1.6 Switch facility patch board cabinet power ON.

9.1.7 Wear hard hat when advised by Facility Operator that he is ready to pressurize the system.

9.1.8 Limit pedestrian traffic to outside of test area perimeter.

9.1.9 Check to assure that the carriage assembly is physically against the top of the thrust column. Check rail clamps.

9.1.10 Check that the carriage assembly and test package are cleared of loose hardware.

9.1.11 Check that the BRAKE PRESSURE flexible hose, instrumentation cable, and tape measure attached to the carriage assembly will be free of obstructions as they travel with the carriage assembly.

## 9.2 Test

CAUTION: DO NOT exit from under the protective overhead screen until the Post-Firing phase of operations.

9.2.1 Switch the Firing Mode to AUTO.

9.2.2 Upon instruction from the Facility Operator, switch the AUTOMATIC FIRE-START to COUNTING.

9.2.3 Upon hearing from the Instrumentation Operator that the count-down is in progress, switch on (up) and hold the detent FIRE ENABLE switch.

## 9.3 Post-Firing:

9.3.1 Release and cover the detent FIRE ENABLE switch.

9.3.2 Check that the carriage assembly brakes are holding adequately.

9.3.3 Measure the final height of the carriage assembly.

9.3.4 Switch the AUTOMATIC FIRE-STOP to RESET.

9.3.5 Stand by to assist in the return of the thrust column to its initial position and the carriage assembly to the top of the thrust column.

9.3.6 Permit the resumption of pedestrian traffic within the test area perimeter.

9.3.7 Record any necessary safety remarks on the 6" HYG E Test Log.

## 9.4 Facility Shutdown:

9.4.1 Assist the Facility Operator in shutting down the facility.

9.4.2 Remove TEST IN PROGRESS poster from personnel door in R112. Remove barricade.

9.4.3 Close the south door of the double-door set between R112 and R112A.

9.4.4 Remove the test area perimeter and return to storage.

9.4.5 Collect hard hats and return to storage.

## APPENDIX I - C

### 1. TITLE: RESTRAINT PROGRAM.

6" HYGE Vertical Impact Facility - Facility Operator's Operating Instructions.

2. PURPOSE: To establish standard operating procedures for the Facility Operator to assure proper setup and operation of the test facility equipment.

3. SCOPE: This instruction outlines in detail the functions to be performed in the different phases of operation.

The following instructions are used for the Restraint Program only. This program requires the rapid return of the carriage and test specimen to the principal investigator following the test event. Motion-picture cameras are utilized. The HY-6407 assembly configuration includes a deceleration metering pin and a deceleration orifice plate. Therefore, a method is included which permits measurement of the hydraulic fluid prior to and between tests without the need to remove the cap from around the thrust column.

4. SUPPLEMENTARY DOCUMENTATION: Reference Section 2, MAINTENANCE INSTRUCTIONS.

### 5. HAZARDS AND PRECAUTIONS:

5.1 All personnel working in the test area must be cautioned about the proper use of the test facility and safety measures to be taken.

5.1.1 The facility must not be approached when Brake, Load, and/or Trigger pressures are being filled or are up to desired operational pressure.

- a. Wear protective hard hat when vertical actuator is being pressurized.
- b. Maintain orderly, safe work environment.
- c. Handle high-pressure nitrogen cylinders with extreme caution.
- d. Check carriage assembly for loose bolts, tools, etc., prior to filling to selected load pressure.
- e. Check that the carriage assembly is physically against the top of the thrust column.
- f. Check that the brake-pressure hose, instrumentation cable, and tape measure are clear of obstructions.

6. EQUIPMENT REQUIRED:

6.1 Protective hard hat.

6.2 Nitrogen supply.

6.3 Tape measure.

6.4 FACILITY OPERATOR'S CHECKLIST

7. GENERAL: The operating techniques and instructions outlined in this document, when used in conjunction with the supplementary documentation, provide a means of assuring consistent, reliable performance of the vertical impact facility as well as the safety of personnel.

8. RESPONSIBILITY: The Facility Operator has the responsibility for the implementation of test requirements assigned by the Test Conductor, and assuring proper setup and operation of the equipment. He is responsible for the operation and overall performance of the mechanical equipment, and for recording and documenting performance. He is responsible for initiating corrective action to maintain the system in a ready condition.

9. DETAILED PROCEDURES: These procedures are in five sections: 9.1 Facility Setup, 9.2 Pre-Test, 9.3 Test, 9.4 Post-Firing, and 9.5 Facility Shutdown.

9.1 Facility Setup:

9.1.1 The Test Conductor will advise all test personnel of the time, nature, and number of tests.

9.1.2 Replace nitrogen cylinders with gas pressures less than 200-300 psig above their respective desired SUPPLY pressures. See 7.5 Nitrogen Supplies of Maintenance Instructions.

9.1.3 Assemble required HYGE base, cylinders, orifice plates, metering pins, and thrust column.

9.1.4 Meter required hydraulic fluid. Record quantity and height. Then assemble required cover.

9.1.5 Install a Trigger Pressure bleed (ball) valve between the Trigger Pressure entrance-port tee fitting and the vented cap initially on the dead end of the tee. Open the valve.

9.1.6 Check all pneumatic lines, including both SUPPLY manifolds, for leaks. Check all flexible hoses and their fittings. See 7.4.1 Control Console of Maintenance Instructions.

9.1.7 Complete Configuration section of 6" HYG E Test Log. Coordinate with Test Conductor. Complete any remaining entries jointly with Test Conductor.

## 9.2 Pre-Test:

9.2.1 Position the acceleration metering pin with assembled components against the acceleration orifice plate.

9.2.2 VENT the LOAD, TRIGGER, and SET PRESSURES. Close all VENT VALVES. Close Trigger Pressure bleed valve.

9.2.3 Lift carriage 20-24" above thrust column. Fasten rail clamps to hold carriage.

9.2.4 Open low-pressure manifold cylinders, regulator, and supply valve; set regulator delivery pressure to 100-150 psig.

9.2.5 Open high-pressure manifold cylinders, regulator and supply valve; set regulator delivery pressure to 100-150 psig.

9.2.6 FILL BRAKE PRESSURE to 100 psig.

9.2.7 Use LOAD and SET PRESSURE gauges on top of the console. (Referred to as #2 LOAD and #2 SET PRESSURE gauges.)

9.2.8 Fill #2 LOAD PRESSURE to 10-15 psig. Piston assembly should lift off, or "pop off," the acceleration orifice plate; then continue a slow rise.

9.2.9 When lift is completed VENT #2 SET PRESSURE. Remove cap fitting. Dip stick and record hydraulic fluid height. Replace cap fitting.

9.2.10 Fill #2 SET PRESSURE to 20 psig. VENT #2 LOAD PRESSURE slowly down to 10 psig. Maintain a 10 psi differential pressure. At approximately four inches above the acceleration orifice plate, the piston assembly may quickly and noisily seat on the plate. Close all FILL and SUPPLY valves.

9.2.11 VENT #2 LOAD and TRIGGER PRESSURES. VENT #2 SET PRESSURE. Close all VENT valves.

9.2.12 Position the acceleration metering pin with assembled components against the acceleration orifice plate.

9.2.13 Open Trigger Pressure bleed valve.

9.2.14 Release carriage rail clamps.

9.2.15 VENT BRAKE PRESSURE, lowering the carriage assembly to the top of the thrust column.

9.2.16 Secure the test package.

9.2.17 Secure the necessary ballast weights.

9.2.18 Secure cloth tape measure to carriage clip. Pull out sufficient length of tape. Note and record pre-test reference height.

9.2.19 Complete pre-test portion of 6" HYGE Test Log including Set, Brake, Load and Trigger Pressures.

9.2.20 Switch console 120V and intercom POWER to ON.

9.2.21 Begin to wear hard hat.

9.2.22 Advise all test personnel of readiness to pressurize system.

9.2.23 Reset low-pressure regulator delivery pressure.

9.2.24 Reset high-pressure regulator delivery pressure.

9.2.25 Open console LOW PRESSURE and HIGH PRESSURE SUPPLY valves; readjust manifold regulators.

9.2.26 FILL to selected SET PRESSURE and close valve.

9.2.27 Check to assure that the carriage assembly is physically against the top of the thrust column. Check rail clamps.

9.2.28 Clear carriage assembly and HYGE assembly of loose hardware.

9.2.29 Check that the BRAKE PRESSURE flexible hose, instrumentation cable, and tape measure will be free of obstruction as they travel with the carriage assembly.

### 9.3 Test:

CAUTION: DO NOT exit from under the protective overhead screen until the Post-Firing phase of operations.

9.3.1 FILL to selected BRAKE PRESSURE and close valve.

9.3.2 FILL to selected LOAD PRESSURE and close valve. (Load Pressure, maximum  $\leq 5.5 \times$  set pressure).

9.3.3 FILL to selected TRIGGER PRESSURE and close valve.

9.3.4 Check that console instrumentation panel firing mode switch is to AUTO.

9.3.5 Advise all test personnel that all pressures are up and of readiness to activate countdown START switch. Wait for all affirmative replies.

9.3.6 Instruct the Safety Monitor to activate the countdown AUTOMATIC FIRE-START switch to COUNTING.

9.3.7 Upon hearing that the countdown is in progress from the Instrumentation Operator, switch on (up) and hold the detent FIRE ENABLE switch.

9.3.8 Listen for camera motors to start at T-02. Should cameras fail to start, release the detent FIRE ENABLE switch (down).

#### 9.4 Post-Firing:

9.4.1 Release and cover the detent FIRE ENABLE switch.

9.4.2 Check that the carriage assembly brakes are holding adequately.

9.4.3 Record the final height of the carriage assembly.

9.4.4 Close the Trigger Pressure bleed valve.

9.4.5 VENT the SET PRESSURE and the LOAD PRESSURE simultaneously, maintaining a minimum of 100 psi positive LOAD PRESSURE differential.

9.4.6 VENT the #2 SET PRESSURE to zero. Close VENT valve.

9.4.7 VENT the #2 LOAD PRESSURE to 20 psig. Close VENT valve.

9.4.8 VENT BRAKE PRESSURE to approximately 50 psig, lowering the carriage assembly to a suitable working height. Close the VENT valve. FILL to selected BRAKE PRESSURE and close valve.

9.4.9 Remove test specimen.

9.4.10 Dip stick and record height of hydraulic fluid.

9.4.11 FILL the #2 SET PRESSURE to 40 psig. Close FILL valve.

9.4.12 Open Trigger Pressure bleed valve.

9.4.13 VENT the #2 LOAD PRESSURE and the #2 SET PRESSURE simultaneously, maintaining a minimum of 10 psi positive #2 SET PRESSURE differential. Close the #2 LOAD PRESSURE VENT at 10 psig.

9.4.14 Use short low-pressure blasts of #2 SET PRESSURE FILL gas, if necessary, to get the thrust piston assembly to seat on the acceleration orifice plate.

9.4.15 VENT #2 LOAD and TRIGGER PRESSURES. VENT #2 SET PRESSURE. Close all VENT valves.

9.4.16 VENT the BRAKE PRESSURE to lower the carriage assembly to the top of the thrust columns. In the event that the carriage begins to descend too rapidly, open the FILL valve (and close the VENT valve). VENT to zero pressure; close the VENT valve.

9.4.17 Check that the carriage assembly is physically against the top of the thrust column.

9.4.18 Close the BRAKE, LOAD, and TRIGGER PRESSURE VENT VALVES.

9.4.19 Complete the 6" HYGE Test Log.

9.4.20 In the event of a follow-on test, continue at 9.2.12.

#### 9.5 Facility Shutdown:

9.5.1 Check both SUPPLY manifold regulator gauges to determine that each SUPPLY has a minimum of 200-300 psig above the next respective specified operational pressures. Note remaining pressure on individual bottle tags. Close both manifold cylinders. Vent the high-pressure manifold line through the console HIGH PRESSURE SUPPLY FILL and VENT valves; close the console HIGH PRESSURE valves when venting is completed. Vent the low-pressure manifold line through the console LOW PRESSURE SUPPLY FILL and VENT valves; close the console LOW PRESSURE valves when venting is completed. Close both manifold regulators and supply valves.

9.5.2 Vent all lines indicating residual pressure in the sequence of LOAD, TRIGGER, SET, and BRAKE.

9.5.3 Inform Principal Investigator of test results and provide any additional data requested.

## APPENDIX I - D

### 1. TITLE: RESTRAINT PROGRAM.

6" HYGE Vertical Impact Facility - Safety Monitor's Operating Instructions.

2. PURPOSE: To establish standard operating procedures for the Safety Monitor to assure satisfactory test area safety.

3. SCOPE: This instruction outlines in detail the functions to be performed in the different phases of operation.

The following instructions are used for the Restraint Program only. This program requires the rapid return of the carriage and test specimen to the principal investigator following the test event. Motion-picture cameras are utilized. The HY-6407 assembly configuration includes a deceleration metering pin and a deceleration orifice plate. Therefore, a method is included which permits measurement of the hydraulic fluid prior to and between tests without the need to remove the cap from around the thrust column.

4. SUPPLEMENTARY DOCUMENTATION: Reference Section 2, MAINTENANCE INSTRUCTIONS.

### 5. HAZARDS AND PRECAUTIONS:

5.1 All personnel working in the test area must be cautioned about the proper use of the test facility and safety measures to be taken.

5.1.1 The facility must not be approached when Brake, Load, and/or Trigger pressures are being filled or are up to desired operational pressure.

- a. Wear protective hard hat when vertical actuator is being pressurized.
- b. Maintain orderly, safe work environment.
- c. Check carriage assembly for loose bolts, tools, etc., prior to filling to selected load pressure.
- d. Check that the carriage assembly is physically against the top of the thrust column.
- e. Check that the brake-pressure hose, instrumentation cable, and tape measure are clear of obstructions.

### 6. EQUIPMENT REQUIRED:

- 6.1 Protective hard hat.
- 6.2 TEST IN PROGRESS poster.
- 6.3 SAFETY MONITOR'S CHECKLIST.
- 6.4 Perimeter stands and webbing.

7. GENERAL: The operating techniques and instructions outlined in this document, when used in conjunction with the supplementary documentation, provide a means of assuring consistent, reliable performance of the vertical impact facility as well as the safety of personnel.

8. RESPONSIBILITY: The Safety Monitor has the responsibility for the implementation of safety requirements, and assuring proper setup and monitoring of safety conditions. He is responsible to ensure that only authorized personnel are in the test area and to correct any violation of safety.

9. DETAILED PROCEDURES: These procedures are in four sections: 9.1 Pre-Test, 9.2 Test, 9.3 Post-Firing, and 9.4 Facility Shutdown.

9.1 Pre-Test:

9.1.1 Locate test area intercom at Safety Monitor's station; make operational.

9.1.2 Make hard hats available.

9.1.3 Place TEST IN PROGRESS poster on personnel door in R112 between R112 and R112A. Place a physical barricade against personnel door.

9.1.4 Open south door of double-door set between R112 and R112A to permit pedestrian traffic.

9.1.5 Set up test area perimeter utilizing portable stands placed a minimum of 15 feet from the thrust column. Interconnect stands using half-inch wide yellow webbing.

9.1.6 Switch facility patch board cabinet power ON.

9.1.7 Wear hard hat when advised by Facility Operator that he is ready to pressurize the system.

9.1.8 Limit pedestrian traffic to outside of test area perimeter.

9.1.9 Check to assure that the carriage assembly is physically against the top of the thrust column. Check rail clamps.

9.1.10 Check that the carriage assembly and test package are cleared of loose hardware.

9.1.11 Secure the necessary ballast weights.

9.1.12 Check test package.

9.1.13 Check that the BRAKE PRESSURE flexible hose, instrumentation cable and tape measure attached to the carriage assembly will be free of obstructions as they travel with the carriage assembly.

9.1.14 Open Trigger Pressure bleed valve.

## 9.2 Test:

**CAUTION:** DO NOT exit from under the protective overhead screen until the Post-Firing phase of operations.

9.2.1 Switch the Firing Mode to AUTO.

9.2.2 Upon instruction from the Facility Operator, switch the AUTOMATIC FIRE-START to COUNTING.

9.2.3 Upon hearing that the countdown is in progress from the Instrumentation Operator, switch on (up) and hold the detent FIRE ENABLE switch.

## 9.3 Post-Firing:

9.3.1 Release and cover the detent FIRE ENABLE switch.

9.3.2 Check that the carriage assembly brakes are holding adequately.

9.3.3 Measure the final height of the carriage assembly.

9.3.4 Switch the AUTOMATIC FIRE-STOP to RESET.

9.3.5 Assist in the lowering of the carriage assembly to a suitable working height.

9.3.6 Remove test specimen.

9.3.7 Remove cap fitting. Dip stick height of hydraulic fluid.  
Replace cap fitting.

9.3.8 Stand by to assist in the return of the thrust column to its initial position and the return of the carriage assembly to the top of the thrust column.

9.3.9 Permit the resumption of pedestrian traffic within the test area perimeter.

9.3.10 Record any necessary safety remarks on the 6-in HYGE Test Log.

9.4 Facility Shutdown:

9.4.1 Assist the Facility Operator in shutting down the facility.

9.4.2 Remove TEST IN PROGRESS poster from personnel door in R112.

9.4.3 Collect hard hats and return to storage.

APPENDIX II  
6" HYG E TEST LOG

Test No. \_\_\_\_\_ Date \_\_\_\_\_  
Project \_\_\_\_\_ Investigator \_\_\_\_\_

Objective:  
Wave Form \_\_\_\_\_ Peak G \_\_\_\_\_ Time (MSec) \_\_\_\_\_

Configuration:  
HYGE NO. \_\_\_\_\_ Thrust Column (Inches) \_\_\_\_\_  
Carriage Height, From Top of Base Plate (Inches) \_\_\_\_\_  
Dec. Orifice No. \_\_\_\_\_ I.D. (Inches) \_\_\_\_\_ W/Contour Up/Down \_\_\_\_\_  
Dec. Metering Pin Length From Top of Thrust Piston (Inches) \_\_\_\_\_

MUST Hydraulic Fluid  
\_\_\_\_\_ (In.) Over Top of Thrust Piston/Deceleration Metering Pin  
\_\_\_\_\_ (In.) As Measured Down From Top of Top Cylinder  
\_\_\_\_\_ (In.) Above Deceleration Orifice

CAUTION: Minimum  $\frac{1}{4}$  Inch Above Top of Thrust Piston - FOR LUBRICATION ONLY  
Fluid Volume (Liter) \_\_\_\_\_ Set Length, Net \_\_\_\_\_ (In.)  
Metering Pin Nos. Acc. \_\_\_\_\_ Dec. \_\_\_\_\_  
Dynamic Parts, Inc. Hyd. Fluid \_\_\_\_\_ TOTAL WT. \_\_\_\_\_ (Lbs.)  
Carriage Assy. + Instrumentation \_\_\_\_\_ TOTAL WT. \_\_\_\_\_ (Lbs.)  
Fixtures + Hardware \_\_\_\_\_ WT. \_\_\_\_\_ (Lbs.)  
Test Package Height (In.) \_\_\_\_\_ WT. \_\_\_\_\_ (Lbs.)  
Dummy/Animal \_\_\_\_\_ TOTAL ACC. WT. \_\_\_\_\_ (Lbs.)  
Other \_\_\_\_\_ TOTAL DEC. WT. \_\_\_\_\_ (Lbs.)

Data:  
Facility Op. \_\_\_\_\_ Safety Monitor \_\_\_\_\_  
Serial No. \_\_\_\_\_ Set Pressure \_\_\_\_\_ Read \_\_\_\_\_ Actual \_\_\_\_\_ (PSIG)  
Serial No. \_\_\_\_\_ Brake Pressure \_\_\_\_\_ Read \_\_\_\_\_ Actual \_\_\_\_\_ (PSIG)  
Serial No. \_\_\_\_\_ Load Pressure \_\_\_\_\_ Read \_\_\_\_\_ Actual \_\_\_\_\_ (PSIG)  
Serial No. \_\_\_\_\_ Trigger Pressure \_\_\_\_\_ Read \_\_\_\_\_ Actual \_\_\_\_\_ (PSIG)  
Peak Acceleration, G's \_\_\_\_\_ Time Duration (MSec) \_\_\_\_\_  
Reference Height (In.) Pretest \_\_\_\_\_ Final \_\_\_\_\_ Net Travel \_\_\_\_\_

Other: Remarks \_\_\_\_\_

Calculations: Analysis Programs; H-P Nos. \_\_\_\_\_ Other \_\_\_\_\_  
Velocity, Max. (Ft/Sec) \_\_\_\_\_ Acc. Displacement (In.) \_\_\_\_\_  
Duration (MSec) \_\_\_\_\_ Peak G's \_\_\_\_\_ Av. Dec. G's \_\_\_\_\_  
Calc. Duration (10%/90%) \_\_\_\_\_ Mu \_\_\_\_\_

Reference: Test No. \_\_\_\_\_

## REFERENCES

1. Consolidated Vacuum Corporation/Consolidated Electrodynamics Corporation, Rochester, New York.
  - a) Bulletin No. 4-70, HYGE Shock Testers; Precision Instruments for Shock Simulation.
  - b) Bulletin No. 4-75, Standard Test Methods for Mechanical Shock.
  - c) Bulletin No. 4-71-B, Installation and Operating Instructions for the 6-Inch HYGE Shock Tester.
  - d) Bulletin No. 4-71-A, Foundation and Services for the 6-Inch HYGE Shock Tester.
  - e) Bulletin No. 4-70-D, Installation Instructions for the 20-Foot Rail and Carriage Systems, Type HY-6004.
  - f) Bulletin No. 4-70-F, Installation and Operation of the Safety Interlock Valve for the HYGE Shock Tester.
  - g) Bulletin No. 4-71-C, Replacement Parts for the 6-Inch HYGE Shock Tester.
2. Hack, William F., HYGE Shock Test Facility at 6571st Aeromedical Research Laboratory, ARL-TDR-62-22, Holloman Air Force Base, New Mexico 88330, AD286168 (September 1962).
3. Installation and Operating Instructions for HYGE Shock Tester. VE No. 38326, The Bendix Corporation, June 1972.
4. Shaffer, John T., The Impulse Accelerator: An Impact Sled Facility for Human Research and Safety Systems Testing, AMRL-TR-76-8, Wright-Patterson Air Force Base, Ohio 45433 (August 1976).
5. Military Specification MIL-S-9479B(USAF), General Specifications for Aircraft Upward Ejection Seat System (March 1971).

**END**

**FILMED**

**3-85**

**DTIC**