

AD-A150 780

A PROPOSAL FOR THE KOREAN COMPUTER INDUSTRY(U) NAVAL
POSTGRADUATE SCHOOL MONTEREY CA H S KIM JUN 84

1/1

UNCLASSIFIED

F/G 9/2

NL

END

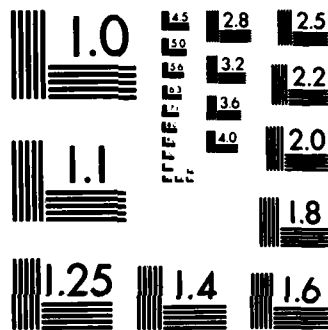

MICROCOPY RESOLUTION TEST CHART
NATIONAL BUREAU OF STANDARDS-1963-A

NAVAL POSTGRADUATE SCHOOL

Monterey, California

AD-A150 780



THESIS

A PROPOSAL FOR THE KOREAN COMPUTER INDUSTRY

by

Kim, Hwa Soo

June 1984

Thesis Advisor:

C. R. Jones

DTIC FILE COPY

DTIC
ELECTE
MAR 4 1985

S
D
D

Approved for public release; distribution unlimited

Block 20 Contd.

development of a single market, and the shortage of software technical personnel), a general proposal for the distant future (i.e., social policy, computer research and development center's establishment, and semiconductor company establishment), and a general proposal for the Korean computer marketing field (i.e., consumer education, low cost and high performance strategies, diversification and differentiation strategies, and focal point strategy). A study of Korean computer companies and government is not completed, and can not be. Therefore, the author's recommendations are described in the Chapter V.

Approved for public release; distribution unlimited.

A Proposal
for the
Korean Computer Industry

by

Kim, Hwa Soo
Lieutenant Commander, Republic of Korea Navy
E.S., Republic of Korea Naval Academy, 1976
B.S., Republic of Korea Korea University, Seoul, 1981

Submitted in partial fulfillment of the
requirements for the degree of

MASTER OF SCIENCE IN COMPUTER SCIENCE

from the

NAVAL POSTGRADUATE SCHOOL
June 1984

Author: _____

Approved by: _____

Thesis Advisor

Second Reader

Chairman, Department of Computer Science

Dean of Information and Policy Sciences

ABSTRACT

The purpose of this thesis was to carry out a simple proposal for Korean computer industry and government. Furthermore, this thesis is a general proposal in terms of social and economic factors as well as technological factors. This thesis includes a general proposal for the near future (i.e., "software houses" activation, development of a single market, and the shortage of software technical personnel), a general proposal for the distant future (i.e., social policy, computer research and development center's establishment, and semiconductor company establishment), and a general proposal for the Korean computer marketing field (i.e., consumer education, low cost/high performance strategies, diversification and differentiation strategies, and focal point strategy). A study of Korean computer companies and government is not completed, and can not be. Therefore, the author's recommendations are described in the Chapter V.

TABLE OF CONTENTS

I.	INTRODUCTION	10
II.	OVERVIEW OF COMPUTER SYSTEMS	12
	A. HARDWARE	12
	1. Central Processing Unit (CPU)	12
	2. Memory (Storage) Unit	13
	3. Input/Output Equipment	15
	E. SOFTWARE	17
	1. Programming Languages	17
	2. Operating Systems	20
	C. COMPARISON OF TYPICAL COMPUTERS	21
	1. Large General-Purpose Computer	22
	2. Mini-computer	23
	3. Micro-computer	25
	D. POTENTIAL APPLICATIONS OF MICRO-COMPUTERS	26
	1. Automatic Data Processing	26
	2. Military Applications	27
	3. Telecommunications	27
	F. HARDWARE AND SOFTWARE TRENDS	30
	1. Hardware Trends	30
	2. Software Trends	32
III.	A STUDY OF THE KOREAN COMPUTER INDUSTRY AND TECHNOLOGY	35
	A. BASIC APPROACH FOR LEARNING COMPUTER TECHNOLOGY	35
	E. CURRENT COMPUTER TECHNOLOGY OF KOREA	37
	1. Hardware	37
	2. Software	39

3.	The Present Status of Korean Computer Companies	40
4.	The Prospect of Computer Technology . . .	42
C.	THE COMPUTER INDUSTRY OF KOREA	43
1.	The Present Status of Computer Installations	43
2.	The present status of the Korean Computer Industry	45
3.	The Prospect for the Computer Industry . .	47
D.	REVIEW	49
IV.	A PROPOSAL FOR THE KOREAN COMPUTER INDUSTRY AND GOVERNMENT	51
A.	A PROPOSAL IN TERMS OF THE NEAR FUTURE . . .	51
1.	"Software Houses" Activation	51
2.	Development of a Single Market Segment . .	53
3.	The Shortage of Software Technical Personnel	54
B.	A PROPOSAL IN TERMS OF THE DISTANT FUTURE . .	56
1.	Social Policy	56
2.	Computer Research and Development Center's Establishment	59
3.	Semiconductor Company Establishment . . .	61
C.	A PROPOSAL FOR KOREAN COMPUTER MARKETING FIELDS	63
1.	Introduction	63
2.	Application Strategies	63
V.	CONCLUSIONS AND RECOMMENDATIONS	70
	APPENDIX A: COMPARISON OF MANUFACTURED GOODS	72
	APPENDIX B: THE MAP OF KOREA	77
	LIST OF REFERENCES	78
	BIBLIOGRAPHY	80

INITIAL DISTRIBUTION LIST 81

LIST OF TABLES

I. Applications of Micro-computers 26

LIST OF FIGURES

2.1	Components of a Computer System	12
2.2	Communicator Processors	28
3.1	Growth of Electronics Industry Production	38
3.2	Status of Computer Purchase	43
3.3	Status of Computer Application	44
3.4	Method of Introduction (Aug/1982)	45
3.5	Components Ratio	46
4.1	Overall Cost Leadership	67

I. INTRODUCTION

A general guideline for the Korean computer industry is needed for developing the computer effectiveness and efficiency. It is the opinion of the author that social and economic factors rather than technological factors will mainly determine the future development of computer technology in Korea. The major advantages that occur from this social and economic perspective are;

(1) The formulation of proper social and economic policies in relation to computers is far more important than the formulation of a technical policy, and will have a greater effect in determining whether or not Korea benefits from the potential of computer technology.

(2) Any attempt to predict future developments exclusively on the basis of technological considerations is doomed to failure.

To develop the Korean computer industry, the author describes four sections of this thesis:

(1) For the purpose of understanding the proposals by non computer professionals, an overview of computer systems is discussed in Chapter II.

(2) In order to suggest the proposals for the Korean computer industry and government, a study of the Korean computer industry and technology is discussed in Chapter III.

(3) A proposal for the Korean computer industry and government in terms of social, economic, and marketing strategies is discussed in Chapter IV.

(4) Conclusions and Recommendations

At the end is an Appendix which contains the list of data elements from major characteristics of manufactured goods of major computer companies and a map of Korea. It is the author's belief that the proposals will be able to be easily applied according to the economical and technological demand of the future.

II. OVERVIEW OF COMPUTER SYSTEMS

A. HARDWARE

The hardware components of a typical computer system are the Central Processing Unit (CPU), Memory Equipment, and Input/Output Equipment. The different components communicate with one another over a group of wires known as a BUS. Figure 2-1 shows the hardware components of a typical computer system.

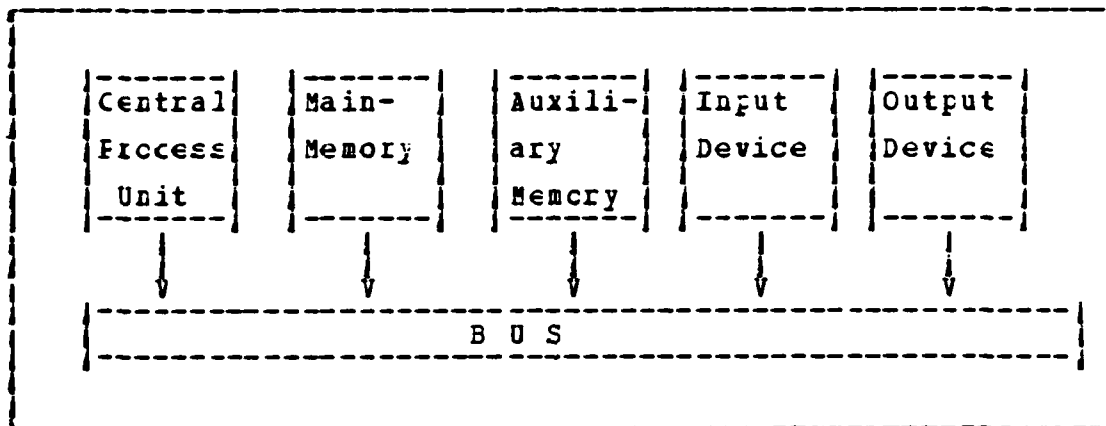

Figure 2.1 Components of a Computer System.

1. Central Processing Unit (CPU)

The CPU corresponds to the brain in human computations. The CPU carries out the calculations called for by the program and controls the other components of the system as well. The central processor operates in fetch-execute cycles. During the fetch part of the cycle, the central processor fetches the next instruction of the program from

main memory. During the execute part of the cycle, the central processor carries out the operation called for by the instruction. If the requested operation requires the use of other hardware components, such as input or output devices, then the central processor sends these devices the necessary control signals so that each device does its part. Therefore, the CPU is a control section of a computer. So, the major functions of the CPU is to control the interpretation and execution of instructions. Especially, in recent years, computer engineers have learned to construct an entire CPU on a small chip of silicon that can be mass produced at low cost. [Ref. 1].

2. Memory (Storage) Unit

The memory unit contains a large number of data and instructions. Also, the memory unit can be divided into two kinds of memory units, that is, the main-memory unit and the auxiliary-memory unit. The memory unit corresponds to the paper used by the human calculator. The purpose of memory unit is to store both instructions and data.

a. Main-Memory Unit

The main-memory is used to store two things, that is, the program that the computer is currently executing and the data that it is currently manipulating. As was described before, the main-memory is a kind of paper or scratch-pad or black board that holds not only the data the computer is working with but the instructions it's following as well. Also, the main-memory is divided into a large number of separate memory cells or memory locations. Each memory location holds a fixed amount of data and has an address by which it can be referred to for the purpose of storing data in it or retrieving data from it. Especially, the main-memory unit can read a large number data and

instructions rapidly. That is, the memory access time is very short. The memory access time is the time required to locate and transmit the information. On the other hand, main-memory is too expensive for long-term storage of large data files and program libraries. [Ref. 2].

k. Auxiliary Memory Unit

The organization of the main-memory unit makes use of transistor circuits. So, the price is very expensive. There are two major types of auxiliary memory units, magnetic tape and magnetic disk.

(1) Magnetic Tape : The advantage of magnetic tape is the ability to store as much data as necessary, because more tape can always be added. The schematic representation of magnetic tape memory will be discussed next. In order to access a particular item of information, the tape must be started and rewound. For example, suppose there are a number of musical selections recorded on a tape. To play the selections in the same order as they are recorded on the tape, there is no problem. Just put on the tape and let it play. But if you want to play a selection near the middle of the tape first, then one near the beginning, then one near the end, and so on, it will waste a lot of time winding and rewinding the tape for the next selection. That is, a drawback of magnetic tape.

(2) Magnetic Disk : Magnetic disks look like phonograph records but work on the same principle as magnetic tape. Most computers use the magnetic disk as auxiliary memory units. So, the magnetic disk is one of the most important equipments in a current computer system. In order to understand how a disk works, one can imagine a phonograph-record-like disk attached to a spindle or spinning rod. An access arm coming in from the side points toward the center of the

spinning disk. The access arm look like a two-pronged fork, with one prong going above the disk and the other below it. At the end of each prong is a read-write head that records and plays back data. The head on the top prong records and plays back from the top surface; the head on the bottom prong does the same from the bottom surface. The access arms can move the read-write heads either in toward the center of the disk or out toward its edge. When a read-write head is in a particular position, the portion of the disk that moves under it as the disk spins is called track. In contrast to tape, disks require no winding or rewinding to access a particular data item. Instead the access arm positions the read-write head over the track containing the desired item. Shortly thereafter, the spin of the disk carries the item beneath the read-write head. Tracks on the disk can be accessed in any order desired; for this reason disks are called random-access media. [Ref. 2].

3. Input/Output Equipment

The function of Input/Output equipment is to provide for communication between the machine and its human users, a means is thus needed to convert information from machine language to human language. There are many different kinds of input/output equipment. But, instead of trying to survey all kinds of input/output equipment, the discussion will focus on computer terminals, key-punches, card readers, and high-speed printers. A computer terminal consists of a typewriter-like keyboard and either a television-like display screen or typewriter-like printer. The terminal is connected to the rest of the computer system by wires, which may be and often are ordinary telephone lines. Data typed on the keyboard is transmitted over the wires from the computer is either displayed on the screen or typed out by the printer.

a. Key-Punch

The most popular kind of punched card is divided into 80 columns, each of which can hold the punched holes representing one character. Thus, a standard punched card can hold one typed line, which may be up to 80 characters long. Punched cards are made with a device known as a keypunch, which is equipped with a typewriter-like keyboard. Data typed on the key-board is punched on the cards. The keypunch will also print the typed characters along the top edge of the card. The printed line is for a human reader; the punched holes represent the same information for the computer. [Ref. 3].

b. Card Reader

To make data punched on cards available to the computer system, the cards are fed into a device known as a card reader, which obtains the data from the cards by sensing the punched holes. The computer system can punch its own cards using an output device known as a card punch. Often a card reader and a card punch are combined in the same unit. [Ref. 3].

c. High-Speed Printer

Often computer systems must produce large amounts of printed output, such as bills for all of a company's customers or checks for all of its employees. For this purpose, a high speed printer is called a line printer. Because it prints an entire line in a single operation. Some high-speed printers can print thousands or even tens of thousand of lines per minute. [Ref. 3].

E. SOFTWARE

The computer system software consists of programs that direct the hardware. The software can be divided into two kinds of software, that is, system software and application software. System software consists of programs that permits the computer to execute other programs. On the other hand, application software consists of programs for doing all the other jobs unrelated to computer operations, such as marketing, payrolls, and playing games. The next portion of the thesis is devoted to system software.

1. Programming languages

The programming language can be divided into machine language, assembly language, and high-level language.

a. Machine language

The central processing unit of a computer system can only execute instructions expressed in a binary-coded form known as machine code or machine language. Programmers usually express machine codes in either octal or hexadecimal notation, depending on which is more convenient for the machine in question. However, there are several problems in machine language.

First; Almost every instruction in a machine language program contains an address referring to a location in main memory. If a program must be revised and it is common to revise programs to meet changing needs, then the locations in which the various instruction and data items are stored will likely change as well. This means that even a small revision may make it necessary to change the address part of almost every instruction in the program.

Second; Machine language programs are phrased in computer-oriented terms. They refer to such features of the internal construction and operation of a computer as the accumulator, the condition-code register, operation code, and main-memory address. [Ref. 1].

b. Assembly Language

The central processor of a computer can not execute assembly language. It can only execute machine codes. Before an assembly language program can be executed by a computer, it must be translated into machine language. Also, there are several problems in assembly language.

First; One must still phrase programs in terms of machine-oriented concepts such as central processor registers and main-memory locations, rather than in terms of the ideas most natural to the problem or to the user.

Second; Each instruction to the computer still has to be broken down into small steps, such as individual loads, stores, additions, and subtractions. [Ref. 2].

c. High-Level Programming Language

In order to avoid the problems of machine and assembly languages, people have devised user-oriented languages, that is, high-level languages. These languages allow programmers to instruct the computer in the terms most natural for a particular problem, user, or field of endeavor. Because there are so many problems, users, and fields of endeavor, there are large number of higher level languages, e.g. BASIC, COBOL, FORTRAN, and PASCAL.

*BASIC --Beginner's All-purpose Symbolic Instruction Code. It was originally designed as an extremely simple language for teaching programming to beginners. Now, BASIC is the

most widely used programming language in education. Because of its simplicity, it is easy to implement on small computers, so many of the small computers now used by individuals, professionals, and small businesses are programmed in BASIC.

*COBOL--Common Business Oriented Language. It is the most widely used programming language in business data processing. [Ref. 3]. COBOL is oriented toward the processing of the large files of data that occur in business applications. The language caters to business users by allowing instructions to be started in English-like words and phrases business people prefer rather than as mathematical formulas.

*FORTRAN -- Formula Translation. It is one of the oldest and most famous languages. As its name suggests, FORTRAN caters to scientists, mathematicians, engineers, etc.. For many years FORTRAN was the only higher level language available on many computer systems, so just about every imaginable computer application has at one time or another probably been programmed in FORTRAN.

*PASCAL--The general-purpose language, which is named after the French philosopher and mathematician Blaise Pascal, has recently become extremely popular for teaching computer science, edging out old standbys like FORTRAN and BASIC. [Ref. 3].

COMPILERS--Of course, a computer's central processor can no longer directly execute a program written in a higher level language than it can execute an assembly language program. The definition of a compiler is as follows:

"A compiler is the software to convert a program in a high level language such as FORTRAN into an assembly language or

machine language program". [Ref. 2]. It is well-known that programming languages increase the ease of communications with a computer. This is so because they often permit ideas to be written down in the order and form that people think of them and because the alternatives, namely, programming is the language of the machine itself is awkward, indirect, complex, and error prone. Thus, there has arisen a vast class of specialized programs (called compilers, interpreters and translators) which transform the raw computing power of a piece of computer hardware into imaginary machines to process program written in synthetic problem-oriented languages. These language translation programs are part of the set of programs that are called "software".

2. Operating Systems

The definition of an operating system is as follows: "We view an operating system as the programs, implemented in either software or firmware, which make the hardware usable. Hardware provides "raw computing power", operating systems make this power conveniently available to users." [Ref. 6]. Next, the functions of an operating system are as follows: An operating system is primarily a resource manager and the primary resource it manages is computer hardware. It provides many features including defining the "user interface", sharing the hardware among users to share data among themselves, scheduling resources among users and recovering from errors. The key resources an operating system manages are processors, storage, input/output devices and data. Operating systems arose principally in response to an increase in the cost and speed of computer hardware. Maybe, in the early days of computing, people sat at the main console, and when they wanted to stop their programs and think for while, they pushed a stop button and permitted the machine to sit idle until they were ready to resume. Also,

the operating system interfaces with computer operators who are people charged with the responsibility of monitoring the operating system, responding to requests for intervention, mounting and dismounting tapes and disks, loading and unloading cards. The operating system interfaces with system programmers and system administrators. The system programmers are generally concerned with maintaining the operating system, tailoring it to the needs of the installation, and modifying it to support new types of devices. Among the above functions of the operating system, it will be discussed about the input/output control system (IOCS) and the loader in detail. The input/output control system is one of the functions of an operating system. This subsystem provides elaborate sequences of the machine commands to control the activities and buffering of the input/output devices. IOCS is divided again, into two major parts, that is, the Foreman or Trap supervisor and the IOCS operating commands and sub-commands. These are programs that issue the actual I/O commands to the devices or controllers, receive I/O traps, report results to other software, keep track of device activity, and provide error-recovery capabilities. Also, the operating system must also provide programs and sub-programs into the computer memory, loads any required sub-routines, and links the sub-routines and the programs together.

C. COMPARISON OF TYPICAL COMPUTERS

In this section will be discussed several kinds of computer, that is, a large general-purpose computer, a large mini-computer, a small mini-computer, and a micro-computer. The large computer described is an IBM 370 model 168, that is a computer widely used for data processing. The large mini-computer described is the Digital Equipment (DEC) PDP

11/45. The small mini-computer is the computer automation NAKED MINI, a popular system computer. The micro-computer is the INTEL MCS-80 based on the widely used INTEL 8080 micro-processor.

1. Large General-Purpose Computer

a. Cost and Word Length

The large general purpose computer is so expensive that it could only serve as a central computer facility for a large institution. The large general-purpose computer would require a specially trained staff of programmers, analysts, and operators, etc .. Also, it has many peripherals, such as card readers, line printers, disk and tape systems, and terminals. The large general-purpose computer could process vast number of records. Also, the word length of the large general-purpose computer has twice as long a word as the mini-computer and four times as long word as the micro-computer. Typically, the large general-purpose computers have word lengths of 32 to 64 bits. On the other hand, mini-computers use 12 to 32 bits, and micro-computers 4 to 16 bits. In order to measure the power of a computer, the word length is an important factor. [Ref. 6].

b. Memory Capacity and Instruction Execute Time

The large general-purpose computer can handle a large amount of programs and data without using secondary storage. Such memory capacity is necessary to handle large files, complex calculations, and detailed reports. For instance, the memory capacity of IBM 370/168 is 8.4 million bytes [Ref. 6]. Also, the large computer is about seven times as fast as the mini-computer.

c. Input/Output Data Rate and Peripherals

The large general-purpose computer can transfer data at a much higher rate than a smaller one. Also, it can utilize high-speed disk systems and other devices that transfer millions of bits per second. In this category, the large general-purpose computer is many times as powerful as the micro-computer. Furthermore, large general-purpose computers, in general, have better instructions and hardware for handling input/output. They have input/output channels and controllers that can be activated with a few instructions and can then transfer large amounts of data without further processor intervention. Many peripherals are immediately available for large computer manufactures and independent peripheral manufactures. The user can purchase fast peripherals for the final product.

d. Software

Much user software is available for large computers; it ranges from common mathematical functions and record handling programs to such highly specialized applications programs as accounting systems for a particular class of engineering problems. The availability of compilers for common computer languages means that the vast backlog of programs written in FORTRAN, COBOL, PL/1 and APL can be used directly large-computers.

2. Mini-computer

a. Cost and Word Length

The large mini-computer is too expensive to be part of a product. However, the applications of large mini-computer are laboratory, small business or small industrial plant. The large mini-computers can also serve as secondary processors for large computers. The small mini-computer is

inexpensive enough to be part of a factory machine, banking terminal, or test system. The word length of large mini-computer and small mini-computer is twice as long a word as the micro-computer and half times as long a word as the large computer. [Ref. 6].

b. Memory Capacity and Instruction Execute Time

The mini-computer has far less memory capacity. So, operating systems, compilers, and other software designed for these computers must occupy less memory or use secondary storage. Mini-computers are generally used in applications involving short programs and small amounts of data. Also, the instruction execute time of mini-computer is one-seventh as fast as the large purpose computer. On the other hand, the mini-computer is four times as fast as the micro-computer.

c. I/O Data Rate and Peripherals

A mini-computer should frequently transfer the data one word at a time. Of course, the mini-computer can't handle high-speed input/output devices. And, the mini-computer can't perform much other work. Few peripherals are available with an off-the-shelf interface for development and for the final product. In other words, mini-computers generally use a few simple peripherals. Such as control panels, numerical displays, keyboards, tele-typewriters, and a paper-tape readers.

d. Software

The user of mini-computers will find far less systems and applications software available. A simple operating system or monitor, an assembler, and a few common compilers or interpreters are all that can be expected. Sometimes even this software requires memory and peripherals beyond those supplied with a minimum system.

3. Micro-computer

a. Cost and Word-Length

The costs of a micro-computer is one-tenth as much as the small mini-computer. It could, therefore, be part of a system costing \$1000, such applications as electronic cash registers, CRT terminals, Counters and small instruments are all possible. Of course, the manufacturer of such items would use many micro-computers, an order of 10000 devices would be considered large. The word length of micro-computer has half as long a word as mini-computer and has one-fourth times as long a word as large computer. [Ref. 6].

b. Memory Capacity

The micro-computer has far less memory capacity than a large computer. That is, it is almost the same as the mini-computer. Especially, micro-computers are slower than mini-computers because their longer word length allows them to address memory more efficiently.

c. Input/output Rate and Peripherals

The maximum Input/Output data rate and peripherals are almost the same as the mini-computer. Especially, micro-computers are used in low-speed applications. Situations involving human interactions, for example, (electronic cash registers or video games) are ideal for micro-computers. Because the response time of a person is about a tenth of a second. Also, paper tape, floppy disk are available for micro-computer in terms of peripherals.

d. Software

The micro-computers, generally, have even less software than small mini-computers. That is, few operating system or compilers are available.

D. POTENTIAL APPLICATIONS OF MICRO-COMPUTERS

Micro-computers are useful for various applications, that is, consumer/institutional, commercial (point-of-sale), military, industrial, data processing and telecommunications. Table I is the example of the wide range of these products. [Ref. 3].

TABLE I
Applications of Micro-computers

Applications	
Consumer	educational systems, intelligent toys and games, programmable appliances.
Data Processing	office computer, I/O controller, programmable calculators, peripheral processors.
Military	navigation systems, simulators and training equipment, communications.
Telecommunications	remote terminals, programmable controllers, switching system, multiplexors, error detection/correction.

1. Automatic Data Processing

It could be applied in support of administrative or management functions. The main advantage is the more timely availability of the required informations. Some reduction in the administrative cost can be foreseen but the order of

this reduction may not be significant. Economy in personnel would not be expected. Generally, this application is a step forward but not of tremendous significance.

2. Military Applications

These applications include reliable modern communications, tactical situation compilation and display, and control of sensors and weapons. The importance of these applications can not be over-emphasized. They provide the means for the effective communications of the modern military warfare.

3. Telecommunications

Telecommunication is one of the most fruitful areas for computer applications. So, this portion will be discussed in detail. The definition of telecommunications is as follows: "The art and science of communicating at a distance, especially by means of electromagnetic impulses, as in Radio, RADAR, TV, Telephone, etc.". [Ref. 4]. There are three major important fields in telecommunication, that is, large scale computer networks, telephony applications, identification systems.

a. Large-Scale Computer Network

Large-scale computers and associated networks are directed at a narrow market of specialized users. Narrow market means that many banking and financial applications, insurance, reservation systems, etc.. Although the market for such applications is a narrow market, it is large and growing in terms of the number of users. Data communication systems can be used to implement a wide variety of specialized data processing applications, that is, message switching, file management, data collection, etc..

*File Management : It refers to the remote updating of a centralized file, or other file handling and processing functions from a remote location.

*Message Switching: It refers to the processing and communication of messages over limited channel capacity systems.

*Data Collection: It refers to the use of a remote station to provide updated or current information to a centralized file. In order to design a data communication, the transmission technology, communication technology and network structure and technology should be considered. The basic role of a micro-processor in a data communication system is that of acting as a communication processor. The role of a communication processor is to interface or "Front End" the host processor with the communication channel (See figure

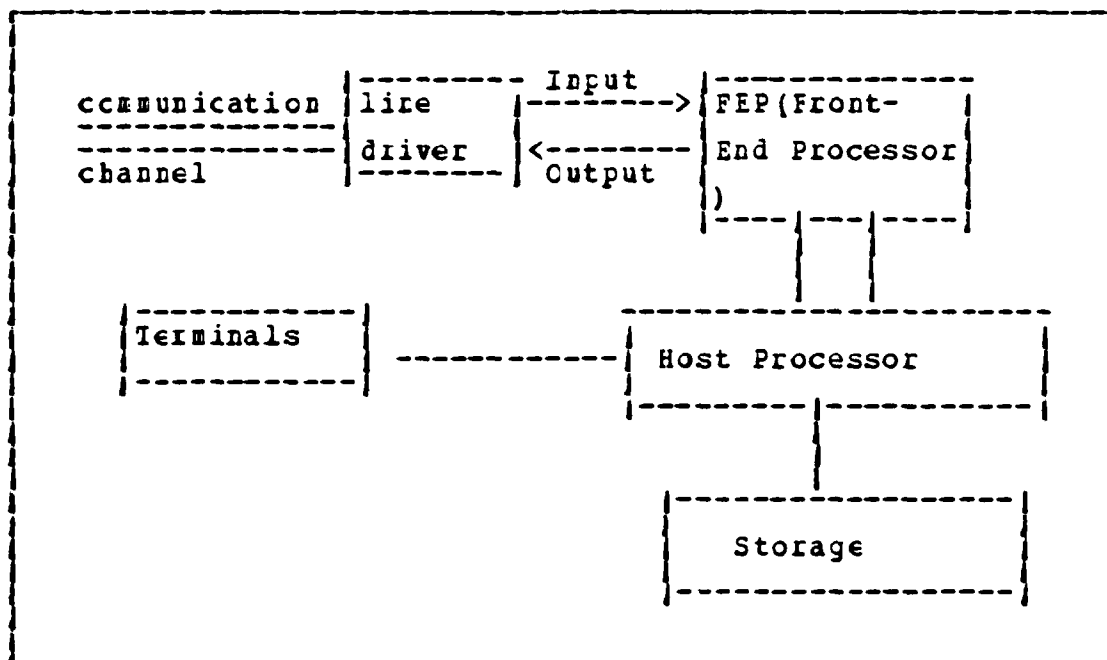

Figure 2.2 Communication Processors.

2.2). Also, there are general functions in a computer network, that is, scheduling, polling, storage and buffering, data link control, code conversion, etc.. Now, many of the above functions are performed by using micro or mini-computers. Also, in order to perform distinct functions in a data communication system, the micro-processor can be used. For example, protocol handling, error checking, packet message formation, synchronization and multiplexors. [Ref. 3].

t. Telephone Applications

The particular applications of micro-processors in telephony applications are as follows:

Switching systems, digital speech encoding, digital filters and transaction telephone systems. Also, the field of computer communications through the switched telephone network is an important area.

1) Telephone Switching System provides communication links between specified lines in response to subscriber requests. The switching network is the means of internal junction circuits.

2) Digital Speech Encoding is an important aspect of the development of digital facilities in the switched telephone network. There are two types digital speech encoding, that is, delta modulation and pulse code modulation (PCM).

*Delta Modulation: It is based on comparing the input analog signal with a reference signal on a periodic basis. So, depending on the result of the comparison, a digital 1 or 0 is transmitted. The reference signal is most typically obtained by means of a feedback loop from previous input signals.

*PCM : It is based on sampling the input analog waveform at a predetermined rate , quantizing each sample, and coding it in terms of a sequence of pulses. Micro-processors may be utilized in a delta modulation or PCM transmission systems for numeric control and monitoring functions.

3) Digital filters are devices that produce a predetermined digital output in response to a given digital input. The digital filter is useful for telephony, radar, and signal processing. A digital filter consists of elements for multiplication, addition, delay, and storage, to obtain a predetermined transfer function on a given input digital signal. There are two basic types of digital filters, that is, recursive and non-recursive filters. A recursive filter utilizes a feedback configuration to provide an input signal utilizing previously calculated outputs. However, in a non-recursive filter only the input to the filter is used to determine the output signals. [Ref. 3].

c. Identification System

Identification systems are another important application area of telecommunication. The identification systems are used to monitor or control the location of moving vehicles, such as trains, buses, police or other service vehicles, from a central location. The operator may transfer command to a specific vehicle on the basis of the location information which has forwarded from the vehicle to the central station. [Ref. 3].

I. HARDWARE AND SOFTWARE TRENDS

1. Hardware Trends

The hardware is changing constantly. There are several trends in hardware. [Ref. 19].

First; Devices are being increasingly more integrated so that each does more than ever before, many performing functions that might earlier have been performed by two or more devices. Computers are absorbing functions often performed in the past by separate units. The result is that the cost of peripheral control units is declining, and in some configurations, actually disappearing.

Second; As the use of chip technology continues to replace older, more mechanical units, equipment will have fewer moving parts to break down and fewer components. This means that costs will continue to go down, making the use of additional devices more affordable. Furthermore, with fewer moving parts, the opportunities to improve availability with fewer and faster repairs becomes possible.

Third; More vendors are integrating within their products programs once written by users. So, making equipment more reliable, much less expensive, and easier to operate.

In addition to the above trends, firmware will be discussed here. The firmware (the marriage of software and hardware) trends will be discussed in this section. The trend toward the use of firmware, usually in the form of microcode (often residing on diskettes or in chips), has also encouraged vendors to add increasing amounts of self diagnosis in their equipment. These aid service personnel and users in keeping devices operational for longer periods of time between breakdowns, while reducing the cost of maintenance. Such diagnostic and correcting tools identify a variety of problems and can even correct some of them.

2. Software Trends

a. Programming Languages

Before looking over the programming language trends in software trends, the major problems of current programming languages will be discussed. For many years, language design has been based on the computer architecture of the time. For many years, the computer designers have attempted to improve on the Von Neumann architecture. Similarly, the language designers have attempted improve the conventional programming language without attempting to design an innovative programming language. In other words, current programming languages are based on Von Neumann computer. So, they are built around a bottle neck: Word-at-a-Time. In brief, conventional programming languages are imperative, not functional. Under this large more complex computer system, more difficulty and problems arise. There are also software cost problems in the conventional programming language. Nowadays, as was described before, the hardware cost is becoming relatively less than the software cost in computer systems. This means that the software cost is coming up continuously. There are numerous duplications in cost of design, implementation, testing; maintenance and training that must be repeated for the translators, software tools, application software and support packages have the excessive cost. The general trends to design of the new programming language of the future will be discussed at the next. [Ref. 21].

1) The new programming language will be easy to learn in basic use and clearly understood. The designer should take into consideration all kinds of principles in order to design the new programming language. And then, the simplicity principle will be the most important principle among several principles.

- 2) The new programming language will be convenient for documentation.
- 3) The new programming language will be appropriate for use in a wide range of machines and will take into consideration cost, efficiency, correctness and ease of communication.
- 4) The new programming language will take into consideration user friendliness.

k. Operating System

A number of operating system trends is given below. [Ref. 5].

- 1) Multiprocessing will become much more common. In multiprocessing systems, several processors share a common primary storage and a single operating system. Multiprocessing introduces the potential for certain types of conflicts that do not occur in uniprocessor systems. It is necessary to sequentialize access to a shared storage location so that two processors do not attempt to modify it at the same time, possibly scrambling its contents.
- 2) Many of the operating systems functions now performed by software will migrate into microcode.
- 3) The operating systems are being designed to execute concurrent programs more efficiently.
- 4) Massive parallelism will become common. It will become possible to execute parallel programs with great speed because of the very high speed of concurrency.
- 5) Operating systems will be designed to foster the operation of virtual machines. Real machine will be hidden from the user.

6) Developments in software engineering will result in operating systems that are more maintainable, reliable, and understandable.

7) The operating system as a resource manager will endure but the resources being managed will change. In particular, data will be viewed increasingly as a resource to be managed.

8) The concept of distributed processing will cause the development of dispersed operating systems in which operating systems functions are distributed among many processors through large networks and the concept of virtual storage will endure. [Ref. 5].

III. A STUDY OF THE KOREAN COMPUTER INDUSTRY AND TECHNOLOGY

A. BASIC APPROACH FOR LEARNING COMPUTER TECHNOLOGY

Korea is a developing country. Most of the developing countries have no high-level computer technology. So, they should learn about computer technology from well-developed countries such as United States, Japan, and West Germany. Currently, many Korean people are students and researchers in these well-developed nations in order to learn the high-level computer technology. There are three models for learning computer technology: Copy Step, Design Step, Development Step.

In copy step, developing nations attempt to produce the manufactured goods of similar function and performance as the well-developed country's manufactured goods. Initially, they should produce the lower level manufactured goods and as success is achieved, they should produce the higher-level manufactured goods. Because the copy step takes a large amount of time, there is an insufficient amount of available funds to pay for it in total. To offset the cost difference, the companies should produce manufactured goods for profit, investing as much of the profit as possible in the copy step. When the performance of manufactured goods reaches the same demand point comparison with the well-developed country's manufactured goods, they should compete with a low-price strategy. The learning phase of the copy step does not require special technology, so, it is termed the cultivation period. The purpose of the copy phase is to increase the production technique to that of the well-developed countries by using simple copies, maybe by reverse engineering. The personnel expenses are one of the most

important factors in the copy phase; however, most of developed countries have no problem in terms of personnel expenses. Korea's major advantage in this approach is essentially the lower wage rates of its labor force, the productivity of which is at least as high as and probably higher than Japanese and United States counterparts. [Ref. 7]. So, Korea can compete with well-developed countries easily by using lower-price instead of higher-level production technology.

The second approach in the course of learning the technology is the design step. Although, they can produce the manufactured goods of similar performance and function as the well-developed countries, they can not lead the well-developed country's technology without computer (Software, Hardware) design technology. For example, if the well-developed countries develop new manufactured goods or modify the original manufactured goods, problems will develop. That is, they can not enter into competition with only lower-price. Therefore, they can not win with only an imitation (copy). Initially, the basic products were copied from those created in well-developed countries. In the second step, they should strive to improve the products so that their goods will win a share of the market in these same well-developed countries. Generally, in order to produce the higher-level manufactured goods, they should understand the well-developed country's manufactured goods exactly. Also, generally, when some part of manufactured goods is modified, then it is affected for all things of manufactured goods. They should, therefore, take into account all parts of computer manufactured-goods in order to improve the performance and function. That is the distinguishing characteristic of computer hardware and software. In order to increase the performance of original computer manufactured-goods, they

should understand the design of computer manufactured goods. And when the original design of computer manufactured goods is modified, they should understand the effectiveness or influence on the marketplace.

The third approach in the course of learning the technologies is the development approach, the actual production of new manufactured-goods. Therefore, the third step is a significantly higher level step. Occasionally, they can produce the new manufactured goods by using existing (original) technology or new technology. In the development approach, competitors are of no concern, since their efforts must be expended on firmly establishing new products. Also, if marketing conditions are good, then they can control the price of the manufactured goods by themselves. For example, IBM's selectric typewriter and the XEROX copy machine are included in this category.

E. CURRENT COMPUTER TECHNOLOGY OF KOREA

The computer technology will be discussed in terms of software, hardware, the present status of the computer companies, and the prospect of future computer technology.

1. Hardware

The hardware of the computer is very close to the electronics technology. The electronics industry of Korea was only moderately successful in its early stages of development, the total production in 1965 was only \$10 million. In the following years electronics production increased to \$462 million in 1973, an average growth rate of 60 percent per year (See Figure 3.1). [Ref. 7]. Over 80 percent of the production is exported. The major factors responsible for this remarkable growth are as follows:

Category	1965	1966	1972	1973	1981	1982
Consumer goods	5.0	9.9	55.2	135.0	2041.73	2570.40
Industrial Equip	2.1	8.4	25.3	43.0	431.90	571.20
Component	3.5	4.5	127.0	284.0	1295.71	1428
Total	10.6	21.8	207.5	462.0	3769.34	4569.6

(million U.S dollars)

Figure 3.1 Growth of Electronics Industry Production.

(a) An abundant, highly skilled, and literate labor force that works for wages about one-tenth to one-sixth of those in the United States and Japan and has attracted large foreign investment in assembly operations.

(b) The government's effort in developing sound infrastructure (transportation, communication, and electric power).

(c) An aggressive and balanced government development strategy.

The large growth in output was accompanied by a decided shift in the share of the three major categories of electronic goods—consumer electronics, industrial equipment (telecommunication equipment), and components. Computer hardware technology in Korea has been enhanced through present day electronic industry contributions, digital technology, a prime factor in computer hardware, is a leading problem in Korean computer industry. In Korea, older analog

(linear) technology is slowly being replaced by digital technology through consumer acquisitions. To overcome this problem, consumer goods are being stressed because changes in the technology for TV sets, radios, tape recorders, and videos are relatively small and easy to assimilate. In addition, the rapid growth in domestic demand for consumer durables gave strong support to the industry. For a long time, the engineer has learned the digital technology by way of assembling, operating, producing, mending, maintenance, and top-down system design. The purpose of digital technology is to study micro-processors and the hardware bus. Each major computer company in Korea has several excellent engineers who have a good knowledge of digital technology. This means that each major company has the ability to copy at the "board level". Furthermore, they are also able to design at the board level in the near future. [Ref. 10].

In summation, the hardware technology of Korea is in the middle portion of the first and the second phase.

2. Software

Currently, the software technology of Korea is a secondary factor of the computer industry. Although computer software technology tends to lag behind hardware advances, software effectiveness has improved and will continue to do so. Of course, the software technology of well-developed countries were also a secondary development factor at the beginning of computer system advances. Especially, the system software field falls behind hardware in the well-developed countries also. [Ref. 9]. The computer scientists of Korea have studied operating systems and language processors in order to use computer systems. If Korea develops a computer system independently and wants to sell the computer system, then it should have the ability to

maintain the entire system. Therefore, the engineers and computer scientists should understand about the system software, operating system, and language processor. Fortunately, the "Gold-Star" computer company is going to install a "software development center" during 1984. The software development center will study the package for users and the study of BASIC software development. Most of all, the software development center of Gold-Star will try to conduct the modification of BASIC operating system and compiler formats in order to use the Korean alphabet, (Han-Gul). Also, "The Software House" was opened in July of 1983 in Korea. The major purpose of the "Software House" is as follows: Whenever the user wants software, the software house manufactures the software (low-level case) or purchases it from foreign countries and delivers it to the user. [Ref. 8]. Currently, Korea has no highly capable software development houses. Although, they have a few high-level computer technical personnel, they have a lack of software developers. The next chapter will discuss the guideline for software houses. Finally, the software technology of Korea is in the first phase, that is, copy phase among the three phases for learning the computer technology.

3. The Present Status of Korean Computer Companies

There are several major computer companies in Korea. On the basis of Korean Industry Bank's data, the present status of major computer companies will be discussed. The Korea's domestic market, one of the largest in Asia, is almost entirely there because the government has banned the import of assembled computers. So far, the major companies---Gold-Star, Samsung, Daewoo, Hyundai and Oriental Precision Company (OPC)---lag the United States and Japan competition in technology. [Ref. 11]. But, they say they are determined that Korean assembly lines, now churning out

millicms of color televisions, will some day be putting out personal computers [Ref. 11]. Already, Korean companies are doing computer assembly work for United States manufacturers. Gold-Star has two personal computer companies, that is, Gold-Star Tele-Electric Co., Ltd., and Gold-Star Computer. The former is cooperating with Data Product Corporation company of the United States and the latter is cooperating with the Honeywell company of the United States. The Data Product Corporation company is one of the most famous printer makers in the world. So, thanks to the Data Product Corporation company, the Gold-Star Tele-Electric Co., Ltd., produced the M-100, matrix printer. Also, the companies are going to produce the profile disk drive independently in the near future. The Gold-Star Computer is producing the Cathode-Ray-Tube (CRT) terminal which can use both the Korean and English alphabet. Recently, this company developed the 8 bit micro-computer independently, that is, GSDPS 6, model 92, 94, 96. The CPU of GSDPS 6 is Z-80a, and the operating system for GSDPS 6 is CP/M and MF/M. Also, Thanks to Honeywell company's assistance, the Gold-Star Computer produced the general-purpose large scale computer, GSDPS8 (main-frame). The major characteristics of manufactured goods of major computer companies are referred to Appendix A. Next, Sam-Sung Computer company has been assembling and supplying the CRT terminal and printer since 1980. This company's policy has been import the personnel computers from United States and Japan and supply the national marketing. [Ref. 9]. But, In 1982, this company cooperated with Hewlett Packard (HP) company. So, this company is assembling and producing the HP3000 series mini-computer as an original equipment manufacturer (OEM). The Sam-Sung computer company is producing the Smart terminal and are exporting the terminal. Also, Dae-Woo and Hyun-Dai are two of the biggest electronics companies in the country.

But, Lae-woo and Eyun-Dai are not yet in the computer market. Next Oriental-Precision-Company (OPC) is producing the CRT terminal (except logic board) and is exporting a large amount of CRT terminals to Televideo Computer company of United States. And, the CPC is producing the 32 bit computer thanks to Nippon Data General Company. As the author discussed earlier, the major characteristics of manufactured goods of major computer companies are contained in Appendix A.

4. The Prospect of Computer Technology

First of all, it is essential for each company to learn the technology of copying, and the technology for production, as soon as possible. Next, each company must learn the second approach phase, that is, design technology. And then, especially, all computer companies of Korea should try to design the Korean-style computer. Currently, the major computer companies are trying to process the Korean-Alphabet by using existing computers. [Ref. 9]. However, major computer companies are going to develop the Korean Alphabet word processing system in order to understand and use the computer easily. [Ref. 9]. The "prospectors" in the computer industry in well-developed countries are studying Distributed Data Processing (DDP) systems, local computer networks (LAN) and super-computers (The 5th generations computer). Especially, in the software field, the computer scientists are studying both programming language and software development techniques in order to overcome the software crisis, software complexity, and software friendliness. Currently, Korea can not compete with the well-developed countries in terms of higher level computer technology. However, Korea should grasp the prospect of computer technology in the well-developed countries and learn their computer design technology. Furthermore, Korea

will try to enter the third approach phase, that is, development phase. First of all, Kcrea will do two basic things. As was described before, Korea will develop the Korean-style computer in order to use and understand the computer easily. Also, Korea will develop the new computer in order to export it in the distant future.

C. THE COMPUTER INDUSTRY OF KCREA

1. The Present Status of Computer Installations

On the basis of Korea Industry Bank's data, the present status of computer installation will be discussed in

	Large Computer	Large mini computer	Small mini and Micro computer	Total
Dec, 1980	77	254	191	522
Dec, 1981	108	304	221	633
Dec, 1982	134	266	238	738
Aug, 1983	-	-	50,000	-

Figure 3.2 Status of Computer Purchase.

this section. According to Figure 3.2, the total number of computer purchase were 633 units at the end of 1981 year. At that time, the total number of large mini-computer are greater than the total number of small mini-computer and micro-computer. On the other hand, in 1983, the Korean personal computer market began a rapid expansion phase. This has caused the number of small mini-computers and micro-computers to cut distance the total number of main

		Korea	U.S	Japar
Simple	simple calculation	23	-	-
business	business management	53	50	75.8
management	others	15.2	-	-
Prediction and Analysis (Decision Support System)		8.8	50	24.2
Total		100 %	100 %	100 %

Figure 3.3 Status of Computer Application.

frames and mini-computers. Figure 3.3 is the current status of computer application. Today, especially, Korea imports large-general purpose computers and large mini-computers instead of small mini-computers and micro-computers. Therefore, the current status of Korea computer application is for simple business management and simple calculations instead of high-level scientific calculation, prediction and analysis. As was discussed earlier, from Figure 3.2 and 3.3, it is known that Korea purchases predominantly the large-computers rather than smaller-computers. Also, the main purpose of purchasing the computer is for simple calculation and business management rather than prediction analysis (Decision Support System) and high-level scientific calculation. [Ref. 12]. A decision support system (DSS) is defined as an information system designed to provide managers with information to support their decision-making processes; an advanced management information system. [Ref. 10]. Figure 3.4 is the current status of computer introduction methods. From Figure 3.4, it is known 38 percent of computer introductions were introduced by way of

Purchase	Rent/lease	Donation	Total
430	299	10	738

Figure 3.4 Method of Introduction (Aug/1982).

rental/lease. Currently, Korea expends a large amount of money without regard to present status of computer application. [Ref. 9]. For instance, Korea expended \$82 million for rental charges in 1980. On the other hand, Korean computer industry begins to boom for micro-computers in 1983, when some 50,000 units were sold at an average price of \$300. (An addition 10,000 were sold to the government at reduced rate). [Ref. 11].

In summation, if Korean computer companies can produce the computer by themselves, they can reduce the expenditure of the large amount of money in the future. Because Korea should not be expending the rental charges for computers which creates a balance of payment problem.

2. The present status of the Korean Computer Industry

As was discussed earlier, the Korean electronics industry has achieved remarkable growth in terms of both quality and quantity. As the Korean electronics industry keeps up with this remarkable rate of growth, they can compete with the well-developed countries in the electronics industry field. In order to compete with the well-developed countries electronics industry field, Korea should overcome the following significant problem. Figure 3.5 is a components ratio of electronics manufactured goods. Figure 3.5

	Korea (1982)	U.S (1982)	Western Europe (1982)	Japan (1982)
Consumer goods	38.7%	12%	25%	33%
Component	45.3%	24%	19%	31%
Industrial Equip	16%	64%	56%	36%
Remarks	Production	Marketing		

Figure 3.5 Components Ratio.

shows that the largest ratio of electronics manufactured goods are in the United States, Japan and Western Europe. On the other hand, there is only a 16 percent component ratio for industrial equipment in electronic manufactured goods in Korea. In order to keep up with the levels of electronics industry of well-developed countries, Korea should make a radical reform of the component ratio of electronic manufactured goods. It should be increased up to a level of 30 percent. The computer industry will play an important role in increasing the component rate for industrial equipment of electronics manufactured goods in Korea. As a matter of fact, it can be easily recognized from historical, statistical research data of United States, Japan, etc.. [Ref. 13]. [Ref. 14]. [Ref. 15]. [Ref. 16]. Therefore, Korea can take an interest in the computer field, that is, a fastest growth rate, in order to develop capabilities in electronics industry field. Korea has attempt to develop the micro-computer along with large-general purpose

computer, mini-computer, and micro-computer. Because, Korea is a developing country, it is restrained by several constraints, especially, technical personnel and money for the development of all types of computers. The growth rate of the micro-computer in terms of dissemination was about 60-70 percent from 1976 to 1981. [Ref. 8]. In addition to this, Korea's market for micro-computers began to boom in 1983. Also, currently, the technical personnel who have graduated from computer science fields number about 3920. This includes technical personnel who have graduated from colleges and universities as well as, technical colleges. This number includes the people that study computer science, computation and statistical science, and computer and craftsman science. Currently, Korean computer companies have enough technical personnel who have graduated from computer science fields. But, Korean computer companies are faced with shortage of technical personnel. The next chapter will discuss a proposal for solving the problem of software technical personnel shortage.

3. The Prospect for the Computer Industry

The Korean computer industry is driven on the basis of the electronic industry. Especially, Korea got the feasibility by making the CRT terminals. The CRT terminal was made on the basis of television technology. Of course, CRT terminals which were made by Korea are less reliable than one of developed countries. However, in terms of quantity, Korea exported 100 thousands CRT terminal in 1982 and exported 350 thousands CRT terminal in 1983. [Ref. 9]. After looking over, the Korean electronics industry in detail, it can be divided into three kinds of fields: computer, communication, and semiconductor fields. The goal of three fields are to produce the computer independently, produce the communication equipment independently, and

produce the Integrated Circuit (IC) independently, respectively. Currently, the people who are associated with computers argue that the computer industry is the most important field of the three. Also, the other industries argue the same as the computer field's argument. [Ref. 8]. So, top managers will find determining their policies to be a very difficult and painstaking task. As was discussed earlier, Korea is a developing country. So, Korea has several constraints, especially, personnel and capital. Therefore, if Korea drives the three fields simultaneously, then failure may occur. Among the three fields, the communication field has no problem in terms of investment since there is enough domestic marketing. Also, the electronic companies would like to invest in the semiconductor field in terms of long period (strategic view). So, in fact, computer field is the weakest among the three. The domestic marketing of the computer field is very narrow. At present, Korea imports the semiconductor from foreign countries. This makes the computer cost very expensive. Also, most companies which need the computer purchase the computer from well-developed countries. Therefore, the domestic marketing in the computer field is very very narrow. The Korean government announced that they would support the computer information industry. But, the main purpose of the government announcement is to stress the technique of computer applications. The future of the Korean computer industry is very good. The reasons will be discussed on the next paragraph.

First; The major factors which are associated with the computer industry are the communication and semi-conductor fields. Fortunately, the Korean computer industry will be developed effectively since the computer industry is progressing as well as communication and semi-conductor fields in Korea.

Second; As was indicated by the computer industry itself, companies may not follow the well-developed country's work in terms of computer technology. That is, Korea can develop their computer industry without a large amount of investment by analyzing and studying the trial and error techniques of a well-developed country's technology.

Third; The personnel expense is the greatest factor in computer industry. However, the Korean computer industry has a major advantage in this field, that is, the lower wage rates of its labor force.

I. REVIEW

Discussed was the current status and the prospect of the computer technology and computer industry. In addition to the above contents, the approach steps for learning the computer technology was discussed in order to understand the level of current computer technology and guide the direction of current computer technology. As was discussed earlier, there are three approach steps, that is, copy, design, and development for learning the computer technology. According to the approach steps, the current status of the Korean computer technology is involved in the first phase and most companies are trying to learn the product technology. However, some major computer companies are studying the second phase (just in terms of a few fields). Especially, in order to develop the Korean-style computer, they should learn the design technology. The Korean computer industry is in the same early stages as the Korean computer technology. However, the Korean electronics industry should follow the well-developed country's work. That is, the Korean electronics industry should be converted from the consumer-goods to industrial equipment production. Really, the main component of industrial equipment is the computer in

well-developed countries. Therefore, Korean electronics companies are feeling the necessity of conversion and they are investing a large amount of money in the computer, semiconductor, and communication fields. Also, the Korean government announced that they will bring up the computer industry and semiconductor fields during Korea's Fifth Five-Year Plan (1982-1987). Therefore, if they enlarge the domestic marketing and they cooperated with the government the Korean computer industry can learn the design technology in the near future.

IV. A PROPOSAL FOR THE KOREAN COMPUTER INDUSTRY AND GOVERNMENT

A. A PROPOSAL IN TERMS OF THE NEAR FUTURE

1. "Software Houses" Activation

Currently, software technology is more an important factor than the hardware technology. For example, in the early 1950's, hardware cost was substantially greater than software cost, with the former as much as six times as the latter. [Ref. 22]. However, most people faced the "software crisis" ten years ago. So, nowadays, software cost is much more expensive relative to hardware. Therefore, the business strategy of computer companies in well-developed countries was to give software much more emphasis than hardware in terms of marketing policy. In order to keep up with the level of more developed countries, Korea should develop its own software industry. As was discussed earlier, software technology in Korea is currently in its infancy. So far, the Korean government policy for the computer industry has not emphasized software but hardware. Of course, policies concerning hardware are not necessarily bad. However, in a world-wide sense, the computer companies show a tendency to develop software rather than the hardware in order to get the maximum profit. [Ref. 8]. Fortunately, "Software Houses" were established in 1983 in Korea. [Ref. 8]. But, most Software Houses have problems, in the areas of money, technical personnel, etc.. The Korean government should aid in the solution of these problems in order to develop the software fields effectively. In other words, the government should provide concentrated support to the software houses. The United States utilizes a tax credit

system, that is, companies may deduct up to 25% of their software development expenses from their taxable corporate income. The Korean government should also develop a tax credit system for both users and software developers, in order to prime or boost the development of the software industries. [Ref. 8]. Also, it will take a long time to cultivate men of talent to complete the development of higher-level specific software. So, the computer companies will need to invest a large amount of capital, development, marketing and other resources to support Korean computer companies. Subsequently, the effort and investment by various software firms in developing specific software will permit Korean public institutions to leave software development to private software development companies. This action will allow Korean public institutions to return to their originally chartered duties. Namely, the public institutions should try to solve the problems of "software houses" and these companies should respond to a consultation. Furthermore, the Korean government should allow the software companies to participate in the government projects in order to accumulate the software technology. Of course, the "software houses" have a few high-level computer technical personnel, however, they have a lack of computer software breadth. But the problems will be solved in the near future. Currently, the software houses manufacture the software (low-level case) or purchase it from foreign countries and deliver it without studying about the companies demand in detail whenever they want software. The above method can not support the business companies effectively since they don't know the system background exactly. Therefore, the software houses should take into account the system background before delivering the software thus improving the capability of the business company. In other words, the software houses should analyze the problems of

businesses and then try to solve these problems for these businesses. Therefore due to the aforementioned lack of Korean capability in software technical development and the expanding role of AIF in problem solving in this rapidly developing industrial country, it is logical that one aspect of the future of Korea as well as other developing industrial countries lies in the area of computer software development. Therefore, the function of "software houses" is very important to the future growth of the Korean computer industry. The major function of "software houses" should be to develop and manufacture software packages that can standardize applications among countries involved in heavy industrial development. Such commonalty will lend itself to low cost-per unit manufacture and resulting lower cost to the user.

2. Development of a Single Market Segment

As was discussed earlier, the current Korean computer domestic market is very narrow, consisting, in large part, of microcomputers and related equipment such as CRT terminals. In order to increase the market for these computers, Korea must find export markets. Difficulties exist, however, with expanding exportation. Korean computer companies technology is presently at a lower level than many other producing countries. Capital is also scarce. Korean computer companies should therefore concentrate their efforts toward developing one portion of the market only. In particular specializing in the manufacture and exportation of one type computer. In other words, the above argument is that Korean computer companies should specialize or concentrate upon a specific components of computers. This is so at least if Korean computer companies want to go beyond a superficial comprehension and acquire a depth of understanding. Of course, Korean computer companies can't

possibly know about everything. Since Korea is a relative newcomer in the area of techno-industrial development it has limited financial and technical capabilities at its present stage of growth. This limitation inhibits its ability to approach the development of its computer industry in a "macro" sense. On the other hand, as Korea narrows its scope to a range of specific computer production, an understanding of it and an expertise in providing such goods and services can increase accordingly. Also, Korean computer companies are more easily develop a detailed knowledge of specific components of computers than if Korean computer companies produced an entire level of components of computers. Korean computer companies have several constraints, especially, lack of technical personnel and money, for developing computers. Therefore, the above arguments are useful for Korean computer companies. For example, most Korean computer companies has been assembling and exporting CRT terminals. Although the CRT terminal made by Korea are a little less reliable than one of developed countries, Korea exported 100 thousand CRT terminal in 1983. Furthermore, most of business companies would like a distributed data processing system instead of a central data processing are in the future. This is one of the trends of computer data processing. So, the demand for CRT terminals will be increased. Therefore, the possibility of CRT terminal in the world market is good. In summation, it is suggested that the Korean computer companies should study specific priority equipment such as CRT terminal.

3. The Shortage of Software Technical Personnel

As was discussed earlier, currently, Korean computer companies seem to have enough technical personnel who have graduated from computer science fields. But Korean computer companies are faced with actual shortages of technical

personnel. The reasons the computer companies are faced with a shortage of technical personnel are as follows:

First; Shortage of qualified faculty.

Currently, the ratio in professors of Korean computer science fields are Ph.D (24%), M.S (70%), and B.S (6%). [Ref. 8]. Namely, the professors who have the M.S degree are teaching the students of the computer science fields. Furthermore, unfortunately, very few of the faculty have had substantial practical experience in designing and building computer systems in a production environment. It is extremely difficult for someone who has never practiced engineering to teach it. In order to solve the above problem, the university should cooperate with the computer companies. That is, computer industry and university exchange programs for faculty could help to alleviate this problem.

Second; Shortage of lab-work

Generally, the required courses in the computer science fields are Assembler, COBOL, FORTRAN, Data Structure, Programming, Compiler, System Analysis, and several kinds of mathematics. Also, the optional courses are Operational Research, Simulation, Data Base, etc.. These are almost the same computer science fields as those of the United States. But, most Korean universities attach more importance to theory than lab-work. Also, most universities, colleges, and technical colleges purchase only a limited number of micro-computers, so students who are studying in computer science fields have little chance to use the computers. However, the computer software field is measured in terms of practical applications, not pure theory. Most courses must include or be tightly coupled to some sort of lab in which the concepts are put into practice.

On the other hand, the computer companies should remember that the university exists to provide education of lasting value and to teach concepts to which students can turn throughout their careers. Thus, certain training responsibilities will always fall on the computer companies. There are several reasons:

Even if a Korean university education in software field were to attempt to model the "real world" as closely as possible, some problems would arise.

(1) It is very difficult to convey an accurate understanding of budgeting, both in development and operational costs for software systems. This problem is further magnified by the general lack of understanding of cost estimation.

(2) There are important differences between the structure of a group in a software field (where the objective is education) and the structure of a group in the computer industry (where the objectives are to produce an artifact and to serve the individual career goals of the group members).

(3) Industry practices are far from being standardized. At this stage, it would be impossible for any university program to model a general industrial setting for computer system production.

E. A PERSPECTIVE IN TERMS OF THE DISTANT FUTURE

1. Social Policy

As was the case with the Industrial Revolution, the improvement in productivity that computer technology will allow is basically good, since it can be used to create more leisure time and/or a higher standard of living. However, the short-term consequences will be disastrous unless it is properly planned. This is so because, basically, the demand side of

the economy has a much slower response time than the supply side. Therefore, the computer technology can lead to higher unemployment and the unequal distribution of wealth. Unless these changes are predicted and controlled, the Korean society may experience serious unmanageable consequences, and the long-term advantages of the computer technology may be lost. Therefore, the Korean government should take into account the above problems when they plan social policy. The several proposals to solve the above problems will be discussed in this section. For example, the increased level of unemployment that could result from the adoption of the technology. The government policy should not be to prevent labor displacement but to make it acceptable by ensuring that it does not convey social hardship or stigma and by providing the people involved with creative opportunities for the future. Next, the high-level computer technology may create an inequality of earnings. That is, if the productivity of a particular job is greatly increased in comparison with other jobs, then it can be done with less effort or time. Sociologically speaking, caution must be emphasized in the introduction of automation into the work place. The resulting increased productivity at a lower per unit cost may cause or introduce economic inequalities or inequities laid upon the shoulders of those in the work place who do not benefit from this improved technology. The inequities may include, involuntary reduced wages or loss of jobs. The above situation may occur on a macro scale with companies. That is, some of the companies will be able to use the technology to make "disproportional" profits in comparison to those companies who produce at a comparatively inefficient rate due to insufficient technological improvement. This should provide an incentive for improvement. On the other hand, some sectors of the business companies will be unable to benefit to any significant degree. Therefore,

the high-level computer technology may create problems unless it is properly planned. It is likely that computer technology will change the style of government. That is, more effective information collection and analysis can improve the efficiency of government and it will simplify, but impersonalize interactions between government and the individual. In order to deal with the above changes, the Korean government should take into account the following proposals:

(1) Changes in the rules relating to the approval chain which is based on the limitations in existing systems. Currently, in order to obtain approval of a paper, the paper should pass through the following chain, that is, drafter-->section chief-->department manager-->director-->vice president-->president. Therefore, the Korean government should simplify the process of approval.

(2) Simplification of record collection and keeping. Currently, most papers are kept in a filing cabinet. Therefore, theft and loss are quite possible. To solve the problem, the Korean government can use a computer file rather than filing cabinets. Also, exchange of information takes a long time with existing paper system. To solve the above problem, the Korean government should consider the on-line computer system. It does provide for the exchange of information immediately.

(3) Provision of different, (ideally simpler) and more cost-effective paper forms of taxation and tax collection. Well-designed taxatic and tax-collection forms can increase clerical efficiency, improve work flow, and lower system costs. To evaluate a form's effectiveness, the Korean government should keep four principles in mind:

First; The form must be easy to use in the system.

Second; The completed form must be easy to use in the system.

Third; The form should not collect data that will not be used in the system.

Fourth; The form should not be unnecessarily expensive.

2. Computer Research and Development Center's Establishment

Uncertainties concerning the future provide risks for Korean computer companies as well as for the well-developed country's computer companies. Technology forecasting, therefore, is theoretically as essential and valuable for Korean computer companies as for the well-developed country's computer companies. Unfortunately, most Korean computer companies currently have no "Research and Development Center". The main purposes of Research and Development Centers are the support of the Korean computer companies and the development of an effective computer technology. The emphasis of such support should not be towards control applications but towards information handling applications in the office, home, public institutions, and elsewhere. The Korean computer companies should consider organizing Korean electronics Research and Development Center's resources. This includes equipment, money, material, facilities, and personnel. [Ref. 10]. The Research and Development Center would provide a focus for the subject and could play a valuable role by providing technical support services to computer companies. In general, some developing countries believe any research and development is too expensive for them to undertake. This belief is vulnerable on two counts.

First, it is technically possible to do some types of research in small plants.

Second, it is vitally necessary for most developing countries to engage in research to remain competitive. Nevertheless, research and development poses two real problems for a developing country. It consumes both money and management time. If it is unproductive, any research is too costly. If it is productive, however, it may be cost effective and result in increased production efficiencies and resulting cost savings. Korean computer companies can use the following arguments to support establishment of "Research and Development Center".

(1) Korean computer companies can use individual members of university faculties as consultants.

(2) Korean computer companies can use university research groups for consummation of research projects.

It is suggested that Korean computer companies should establish the research and development center in terms of future requirements. After establishment of the Research and Development Center, the following areas should be pursued:

(1) Technical forecasting and policy determination. There is a considerable time-lag between the development of technology and its widespread application. For example, the transistor or high-level computer language can take ten years from concept to commercial application and a further five years before they achieve widespread user impact. [Ref. 18]. Even minor changes like the virtual storage can take five years to develop and a further five years to achieve widespread user impact. By looking over the history, the general trends in computer technology over at least the short and mid term can be predicted without reference to any form of technological forecasting.

(2) Use of computer technology in Government. The Korean government announced that they will use the computer in order to handle public administration effectively and efficiently by 1986. It is predicted that the use of computers in government will be increased. Therefore, Research and Development Centers will prepare for the forthcoming revolution in computer development and application, and will influence both the nature and capability of government, and the efficiency of government processes. An example could be at the statistical level, concerned with census of population, earning, trade, taxation, etc..

(3) Co-operation with Research and Development Centers in other countries. Currently, Korea has low-level computer technology. In order to develop the capability of Research and Development Centers in Korea, there should be international cooperation with Research and Development Centers in well-developed countries. In addition to the above arguments, Korean Research and Development Centers could maintain active monitoring capabilities of foreign activities in order to ensure that they are aware of significant developments.

3. Semiconductor Company Establishment

There can be no doubt that the semiconductor technology has the greatest importance to the military and will become basic to almost every aspect of industry and commerce. Furthermore, the semiconductor component is one of the most important factors in computer industry. Korean computer companies import the semiconductor components from foreign countries. This makes the computer cost very expensive. Of course, Korean computer companies can import the semiconductor components from foreign countries continuously. But, Korea has no significant reserves of natural

resources and the population density is among the highest in the world. So, in order to improve the economic capability and computer technology, Korea should learn the high-level semiconductor technology in the distant future. Therefore, it is suggested that Korean computer companies should establish the semiconductor companies as early as possible. Korea stands face to face North Korea. Korea has been expending large amounts of money for military defense. If a semiconductor industry can be developed in Korea, its products could be used internally by the Korean computer industry and could be incorporated by the military in its future weapons. This would provide further economic growth, another export market and improvements to military equipment and strength. In summation, the strategic nature of semiconductor technology is very useful in both the economic and military sense. Therefore, the semiconductor company's establishment is suggested. Also, the argument in favor of establishing a semiconductor company is a possibility, as the technology stabilizes, there will be good competitive opportunities in this market. In other words, there will exist a very broad domestic and foreign market in semiconductor field. After establishment of the semiconductor company, it is suggested that research in the following areas could lead to midterm pay-off:

- (1) Sensor technology, which will be required for access to micro-computer control.
- (2) Large-scale display, which will be essential to low-cost access to information systems.
- (3) Advanced semiconductor phenomena particularly using the wave characteristics of electrons. [Ref. 18]. In brief, Korean computer companies should establish the semiconductor companies and produce semiconductor product rather than import them from foreign countries.

C. A PERSPECTIVE FOR KOREAN COMPUTER MARKETING FIELDS

1. Introduction

Currently, the domestic marketing of Korean computer product is very narrow. The reasons are as follows:

The semiconductor is one of the most important factors in the computer industry. However, Korea has no high-level technology of semiconductors. So, Korea imports the semiconductors from foreign countries such as United States, Japan, and Western Europe. Therefore, the cost of computers made by Korea is very expensive in comparison to its performance. In addition to the above arguments, Korean computer companies have no high-level technology yet. Most of all, most Koreans don't know the following; What's a computer? Why do we need a computer? How do you operate the computer? For example, if there is little or no interest in the computer, the domestic marketing should be closed. Also, most companies which need the computer purchase the computer from well-developed countries. In summation, the marketing policy of Korean computer companies have some problems. That is, High-Cost/Low-Performance. Especially, there is no education policy for the consumers. Currently, the Korean computer industry is in its early stages. In order to expand the narrow domestic marketing of Korea computer, the application strategies for Korean computer marketing will be discussed in this section.

2. Application Strategies

a. Consumers Education

Currently, most consumers for computer systems are facing five kinds of uncertainty, that is,

(1) Most consumers are a first-time users, most of them don't know computers.

(2) In order to acquire the computer system, the customer must expend a large amount of investment.

(3) Most consumers think that Korean computer technology is low-level. So, most consumers have little confidence in the computer performance.

(4) Most consumers don't know how to operate the computer.

(5) There are doubts as to whether the computer could perform reliably and over the extended period of time as promised by the manufacturer.

Therefore, the Korean computer companies should teach consumers about several topics. At least these aspects of education must be taught to consumers.

(1) Vocational training to explicit information technology.

(2) Adult re-education programs to cope with changing labor patterns as a consequence of the computer technology.

(3) Contextual education to ensure that everyone is aware of the computer technology and its potential consequences.

The main purpose of education for consumers is that, as more and more consumers become knowledgeable about computers, the consumers will buy computers, and the computer domestic marketing will grow naturally. Most of all, Korean computer companies should have an interest in elementary, middle, high school, and college and university students. In other words, Korean computer companies can offer a variety of support to educational institutions in order to expand the narrow domestic marketing in the future. Currently, most consumers can't deal with computers. So, the Korean computer

companies should establish computer education center in Seoul, Bu-San, Dae-Gue, and In-Cheon since Seoul, Bu-San, Dae-Gue, and In-Cheon are four of the largest cities of Korea. In addition to the above argument, discussion of a long term strategy will follow. It is a very important strategy in the distant future. For example, one computer company could donate or sell a computer for a low-price to colleges/universities. Therefore, many students can learn the computer by using the manufactured goods of those computer company. So, when they graduate from their schools, maybe, they could remember the computer company's name. So, they will introduce the manufactured goods of those computer companies to their neighbor (friends). Therefore, more and more, the manufactured goods of those computer company will be expanded. And, after all, domestic computer marketing will grow naturally. From the IBM history, they also used the educational policy in order to assist and teach the consumers. In 1960, the educational allowance policy was "absolutely" one of the "principal forces" in IBM also. [Ref. 17].

k. Low-cost/High-Performance Strategies

Currently, the second growth stage for the computer domestic marketing is ongoing. That is, after the consumers know and understand the computer, the cost/performance strategies can be considered to improve the narrow domestic marketing. This does not mean that the education for the consumers strategy is more important than cost/performance strategies. In other words, they can use the educational and cost/performance strategies simultaneously. And, sometimes, the Korean computer companies may or may not think that the cost/performance strategies is more important than the educational strategy. However, currently, most consumers aren't familiar with computer systems.

Therefore, most of all, at present, the educational strategy is more important than the other strategies. When most consumers understand the computer system, the Korean computer companies should take into account the low-cost/high performance strategies in order to expand the domestic computer marketing. That is, the consumers who know the computer will be interested in low-cost/high-performance. At that time, the cost/performance strategies are more important than the educational strategy. Korean computer companies should learn the current high-level technology from well-developed countries continuously. The reason Korean computer companies should have technical ties with the well-developed countries is as follows; As was discussed before, Korea is a developing country. So, currently the Korean computer technology is in its early stages. Therefore, the Korean computer companies can't get the high-level technology of computer in the near future. On the other hand, the well-developed countries are producing computers with low-cost/high-performance. Also, Korean computer companies can use the overall cost leadership strategy. The overall cost leadership is a classic capitalistic model strategy. From Figure 4.1, the Korean computer companies can choose the point to produce at low average cost. And if there are no competitors in that field, then they can increase the computer price accordingly. That is, they can use the high pricing policy to generate the high profit when there are no competitors. Also, the Korean computer companies can use the low-cost strategy in order to gain enough profit while driving out the foreign competitors in domestic marketing. Korean government announced that the personal computer will be imported tax-free from foreign countries in 1985. Therefore, this strategy will be very useful for Korean computer companies in order to compete with foreign competitors in the near future. Furthermore, the labor wage of

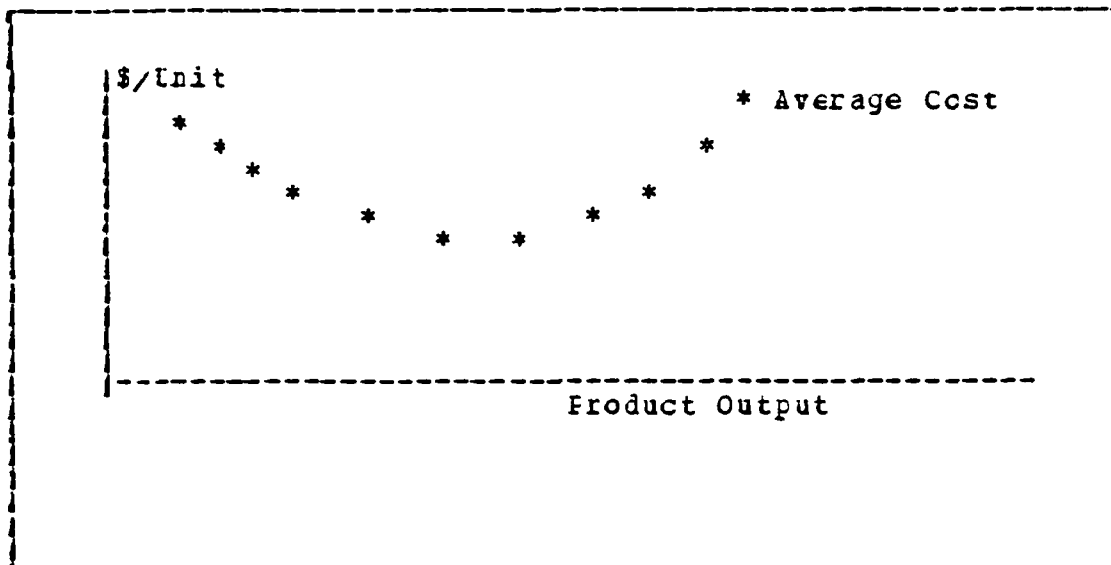

Figure 4.1 Overall Cost Leadership.

Korea is cheap in comparison with the well-developed countries such as United States and Japan. Therefore, Korean computer companies can use the above strategy effectively.

c. Diversification and Differentiation Strategies.

Korean computer companies can also use the Diversification and Differentiation strategies. The diversification strategy means that there are multiple pricing strategies. That is, they can produce several kinds of products in order to compete with competitors. For example, Korean computer companies can produce line printers, mainframes, some automated office equipment, CRTs, etc.. And, the computer companies can take a losing pricing strategy in one product, but still they can get a profit because other products are profitable. The purpose of the losing pricing strategy is to drive out the competitors. In addition to the above Diversification strategy, Korean computer companies can use the Differentiation strategy.

The Differentiation strategy is one of the most generic strategies. That is, it is one of differentiating the product or service offered by the firm, creating something that is perceived industry-wide as being unique. Among the above Differentiation, especially, Korean computer companies can use the Differentiation of the product or service offered by the firm in order to expand the domestic computer marketing. That is, Korea has four large cities, Seoul, Bu-San, In-Cheon, Dae-Gue. In general, the citizens of four large cities have stable income and buying power, which is desirable. And the market will be typical of the national or regional economy and be neither depressed nor computer booming as the result of purely local conditions. Therefore, Korean computer companies can differentiate the products in four large cities. The map of Korea is referred to Appendix B. Also, the Korean computer companies can promise the consumers special services that is not provided until now in order to grow the computer marketing. This is an example of special services for the consumers. If one consumer wants to buy a computer, then the company can promise that they will install your computer, provide special warranties, and we won't charge for special services, etc.. There are other examples of specific services (maybe not concerned with computers). In terms of specific service fields, a barber-shop must provide good haircuts with a minimum of waiting by customers. The television repair shop must repair a television set so that it "stays repaired" for at least a normal interval of time. A photography studio must produce a reasonably good likeness of one who sits for a portrait. [Ref. 20]. Of course, all economic strategies are affected by several environment circumstances. In other words, the theory is not always equal to the practice in real life. Similarly, the Differentiation strategy also has the some risks. By using

the Differentiation strategy, the computer companies will set the price of their products above the minimum average cost according to demand curve. But it will cause another company to take benefit of this, by pricing lower than that price.

d. Focal Point strategy

Some economists say that the Focal Point is not a economic strategy. They say that it is a piece of trickery. [Ref. 8]. However, most economists argued that the Focal Point strategy is a high-level economic strategy which is applied to the people's psychology. Focal points are divided into three kinds of strategies, that is, price, product, and standards. We can see frequently, sales prices of \$1.99, \$15.99, \$10.97, \$199, \$289, in United States. This is an example of Focal Points in terms of price. The Korean computer companies can use this strategies. However, In Korea, the unit of money and people's psychology are much different than those in the United States. Therefore, they should take into account the Korean's psychology when they want to apply the Focal Point strategy. These are good examples of focal point in terms of price in Korea, for examples, ₩299,000, ₩289,000, ₩279,000 (ref: \$1=₩900). But, on the other hand, ₩299,999, ₩289,998, ₩279,997 are not good examples of focal point. Because, the Korean consumers are well aware of the situation already. So, the consumers, may think it is a piece of trickery. Also, the purpose of Focal point strategies is to standardize operations within each industry, so, everyone has its own profit and will not fight each other.

V. CONCLUSIONS AND RECOMMENDATIONS

This thesis project explored the Korean computer industry and technology and provided a general proposal for the Korean computer company which covers:

1. A general proposal for the near future. This includes "software houses" activation, development of a single market segment, and a general idea for solving the problems of technical personnel shortage.
2. A general proposal in terms of the distant future. This includes social policy, computer Research and Development Center's establishment, and semiconductor company establishment.
3. Finally, a general proposal for the Korean computer marketing field. This includes background of Korea computer marketing and several kinds of application marketing strategies.

A study of Korean computer companies and government is not completed, and can not be. This thesis is a general proposal in terms of social and economic factors rather than purely technological factors. Therefore, the author's recommendations are:

1. To continue to detail the general proposals, for the Korean computer companies and government.
2. To support the Korean computer industry completely, including studying and researching the technological factors proposals for the Korean computer industry.

3. To support the Korean computer industry completely, including the proposed solution for the problems of computer hardware technical personnel.

APPENDIX A
COMPARISON OF MANUFACTURED GOODS

This Appendix A explores the major characteristics of manufactured goods of major Korea computer companies.

Manufacturers	Gold-Star	Tri-Gen
Model	Famicon	Tri-Gen 30
CPU model	Z-80A (4MEZ)	6502 (1MHZ)
STORAGE		

Type	ROM, RAM	ROM, RAM
Capacity of basic system	RAM: 16K	RAM: 16K
Maximum Capacity	ROM: 24K	ROM: 12K
	RAM: 16K	RAM: 64K
	ROM: 32K	ROM: 12K
KEYBOARD		

Alphanumeric (Type-writer)	standard	no (63keys)
Parallel connection	no	yes
Full accounting	no	no
Keyboard		

-----	-----	-----
PRINTER		

Type	parallel	parallel/serial
	connection	connection
Graphic	no	yes
-----	-----	-----
SOFTWARE		

BASIC	yes	yes
CCECI	no	no
-----	-----	-----
Number of comm-		
ands, Statemen-	124	100
tions		
-----	-----	-----
FUNCTIONS OF		
COMPILER		

Program	yes	yes
Insertion		
Modification	yes	yes
Deletion	yes	yes
Cursor Control	yes	yes
Line Number	C--65535	0--65535
-----	-----	-----
DISPLAY		
CAPABILITY		

Text	32*16 (C*R)	40*24 (C*R)
Graphic	128*192 (H*V)	280*192 (H*V)
-----	-----	-----

Pricing		

Cassette	\$50	\$62.5
Monitor	\$75	\$112.5--\$162.5
Main-Body (CPU,		
key-board)	\$625	\$625
-----	-----	-----
*****	*****	*****
*****	*****	*****
Manufacturers	Sam-Sung	Korea Commercial
Model	Sic-1000	Spotlight
-----	-----	-----
Storage		

Type	ROM, RAM	ROM, monitor ROM, RAM
Capacity of	ROM:32K	ROM:12K, RAM:16K
basic system	RAM:70K	Monitor ROM:2K
Maximum	RAM:70K	RAM:48K
Capacity		
-----	-----	-----
Key-Board		

Alphanumeric (
Type-Writer)	no (67keys)	yes (72keys)
Full accounting		
Keyboard	no	no
-----	-----	-----

Pritter		

Type	Parallel	Parallel
	connection	connection
Graphic	yes	yes
-----	-----	-----
Software		

BASIC	yes	yes
ASSIMLEF	nc	yes
CCECI	rc	no
-----	-----	-----
Number of comm-		
ands, Statements	155	94
, and Functions		
-----	-----	-----
Functions of		
Compiler		

Program	yes	yes
Insertion		
Modification	yes	yes
Deletion	yes	yes
Cursor Control	yes	yes
Line Number	1--65535	0--65529
Screen Editor	yes	no
Text Edit	yes	yes
-----	-----	-----

Display			
Capability			

Text	32*16 (C*R)	64*16 (C*R)	
		32*16 (C*R)	
Graphic	64*32 (H*V)		
	64*48 (H*V)	128*191 (H*V)	
Pricing			

Monitor	\$125	\$123	
Printer	\$1000	\$1000	
Main-Body (CPU,			
cassette, key-	\$625	\$620	
board)			

APPENDIX B
THE MAP OF KOREA

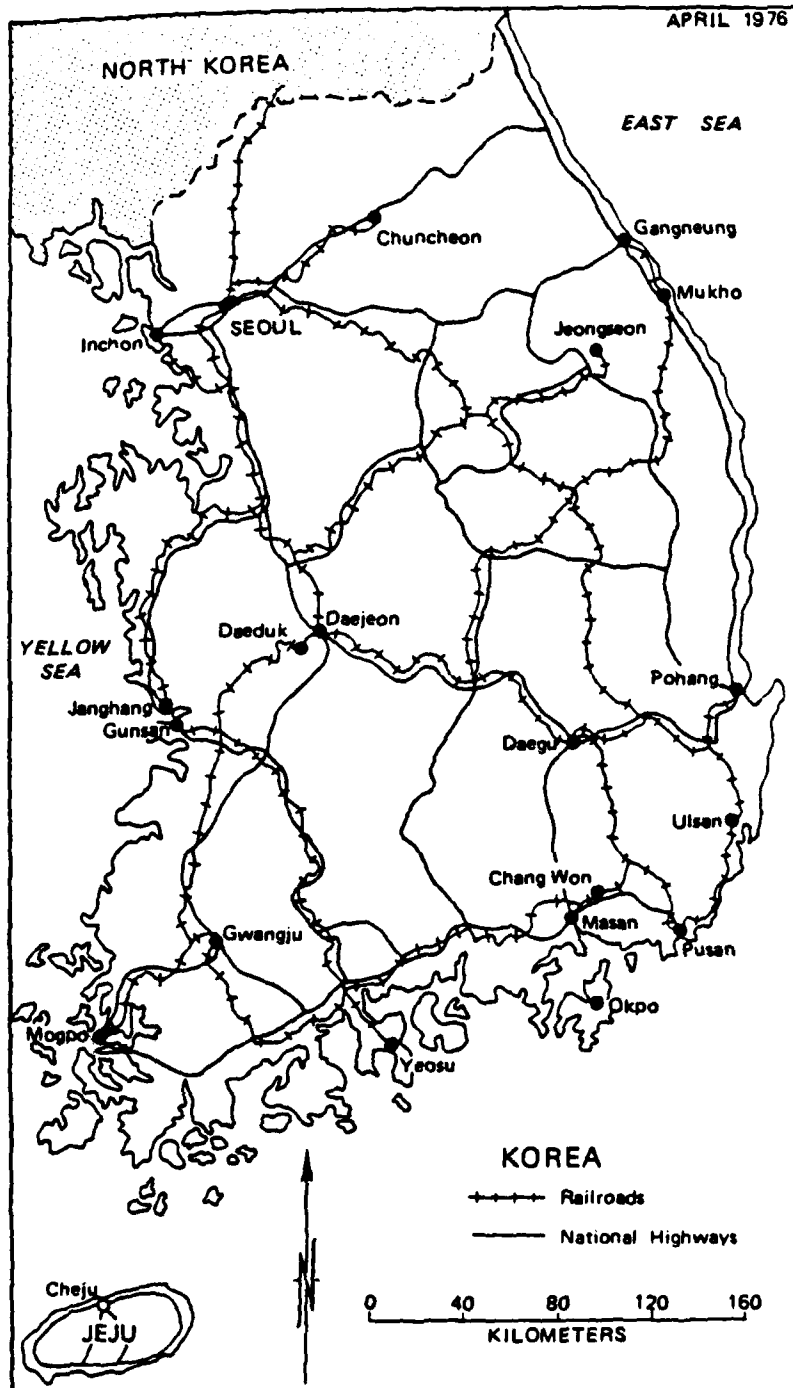

LIST OF REFERENCES

1. Graham, Neill E., Introduction to Computer Science, West Pub. Co., 1982
2. McGlynn, Daniel E., Microprocessors-Technology Architecture and Applications, Wiley-Interscience, 1976
3. Soucek, E., Minicomputers in Data Processing and Simulation, Wiley-Interscience, 1971
4. Eccch, Udo W., Williar H. Greene, Gary G. Moss, Teleccmmunications and Networking, Prentice-Hall, Inc., 1983
5. Deitel, H.M., An Introduction to Operating Systems, Addison-Wesley Pub. Co., 1981
6. Ieventhal, Lance A., Introduction to microprocessor: software, hardware, programming, Prentice-Hall, Inc., 1981
7. Farvez Hasan, Korea, Jchrs Hopkins University Press, 1977
8. The Management and Computer, Korea Monthly Magazine, Donga Press, April 1983
9. Shir-Long-A, Korea Monthly Magazine, Donga Press, May 1983
10. Gore Marvir, John Stubbe, Elements of System Analysis, Wm. C. Brown Company Publishers, 1983
11. Jcrnal Street Newspaper, Feb 21, 1984
12. Han-Kcok Il Bo, Korea Daily Newspaper, Jan 18, 1984
13. Korea Electronics Industry Development Committee's Magazine, Sam Ewa Press, 1981
14. "The Present Status of the United States Computer Industry", EIA, Prentice-Hall, Inc., 1982
15. "The Computer Components Ratio", Electronics, Tokyo Press, 1982

16. "The Present Status of the Japanese Computer Industry", Japan Electronics Industry, Tokyoc Press, 1983
17. Fisher, Franklin M., James W. Mckie, Richard E. Marcke, IBM and the U.S Data Processing Industry, Praeger Publishers, 1983
18. Barroni Iann, Ray Curnow, The Future with Microelectronics, Nichols Pub. Co., 1979
19. Cortada, James W., Managing DP Hardware, Prentice-Hall, 1983
20. Erccn, H.N., Jsting G. longenecker, Small Business Management, South-Western Pub. Co., 1975
21. MacIernan, Bruce J., Principles of Programming Languages, CBS College Publishing, 1983
22. Freeman Peter, Anthony I. Wasserman, Software Design Techniques, IEEE Computer Society, 1983

BIBLIOGRAPHY

Porter, Michael E., Competitive Strategy, Prentice-Hall,
1980.

INITIAL DISTRIBUTION LIST

	No. Copies
1. Defense Technical Information Center Cameron Station Alexandria, Virginia 22314	2
2. Library, Code 0142 Naval Postgraduate School Monterey, California 93943	2
3. Department Chairman, Code 52 Department of Computer Science Naval Postgraduate School Monterey, California 93943	2
4. Professor C. R. Jones, Code 54Js Department of Administrative Science Naval Postgraduate School Monterey, California 93943	1
5. Professor U. R. Kodres, Code 56 Department of Computer Science Naval Postgraduate School Monterey, California 93943	1
6. Ewa Soc Kim, Department of Communication Republic of Korea Naval Headquarters Secul 150-09, Korea	7
7. Computer Technology Curricular Officer, Code 37 Naval Postgraduate School Monterey, California 93943	1
8. Library, Code 1-1 Naval Academy Chir-Hae 602-00, Korea	1
9. Library, Code 1-1 Naval Command and Staff College Chir-Hae 602-00, Korea	1

END

FILMED

4-85

DTIC