

AD-A150 883

PIEZOELECTRIC AND ELECTROSTATIC POLYMERIC TRANSDUCERS
FOR ACOUSTIC EMISSION (U) UNIVERSITY COLL OF NORTH WALES
BANGOR SCHOOL OF ELECTRONIC EN. D K DAS-GUPTA ET AL.

1/1

UNCLASSIFIED

DEC 84 DAJA45-83-C-0008

F/G 9/1

NL

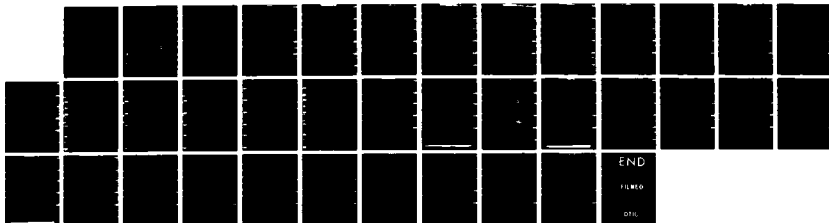

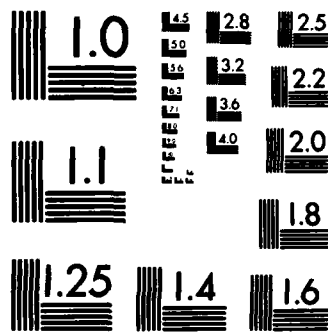

MICROCOPY RESOLUTION TEST CHART
NATIONAL BUREAU OF STANDARDS-1963-A

| REPORT DOCUMENTATION PAGE | | READ INSTRUCTIONS BEFORE COMPLETING FORM |
|---|-----------------------|---|
| 1. REPORT NUMBER | 2. GOVT ACCESSION NO. | 3. RECIPIENT'S CATALOG NUMBER |
| 4. TITLE (and Subtitle) Piezoelectric and Electrostatic Polymeric Transducers for Acoustic Emission Detection | | 5. TYPE OF REPORT & PERIOD COVERED Final Technical Report Dec 82 - June 84 |
| 7. AUTHOR(s) Dr. D.K. Das-Gupta Dr. K. Doughty | | 6. PERFORMING ORG. REPORT NUMBER |
| 9. PERFORMING ORGANIZATION NAME AND ADDRESS School of Electronic Engineering Science University College of North Wales Dean Street, Bangor, Gwynedd LL57 1UT | | 8. CONTRACT OR GRANT NUMBER(s) DAJA45-83-C-0008 |
| 11. CONTROLLING OFFICE NAME AND ADDRESS USARDSG-UK Box 65 FPO NY 09510-1500 | | 10. PROGRAM ELEMENT, PROJECT, TASK AREA & WORK UNIT NUMBERS 61102A 1T161102BH57-03 |
| 14. MONITORING AGENCY NAME & ADDRESS (if different from Controlling Office) | | 12. REPORT DATE December 1984 |
| | | 13. NUMBER OF PAGES 33 |
| | | 15. SECURITY CLASS. (of this report) Unclassified |
| | | 15a. DECLASSIFICATION/DOWNGRADING SCHEDULE |
| 16. DISTRIBUTION STATEMENT (of this Report) Approved for Public Release; distribution unlimited | | |
| 17. DISTRIBUTION STATEMENT (of the abstract entered in Block 20, if different from Report) | | |
| 18. SUPPLEMENTARY NOTES | | |
| 19. KEY WORDS (Continue on reverse side if necessary and identify by block number) Acoustic Emission Detection; Transducer; Polymer; Piezoelectric; Electrostatic; Polymer Film; Broadband | | |
| 20. ABSTRACT (Continue on reverse side if necessary and identify by block number) The work performed during the contactual period falls into three distinct parts:- i) the fabrication of ultrasonic transducers for acoustic emission (A.E.) detection using polyvinylidene fluoride (PVDF) active elements. ii) the fabrication of electrostatic transducers using thin films of non-polar polymers such as polypropylene and polytetrafluoethylene. iii) the development of a flexible composite material with piezoelectric | | |

AD-A150 883

DTIC FILE COPY

DTIC
ELECTED
MAR 6 1985
A

UNCLASSIFIED

SECURITY CLASSIFICATION OF THIS PAGE(When Data Entered)

20. Contd.

properties using powdered ceramic (PZT) dispersed in a polymer matrix.

The first period report dealt with the design and characterization of PVDF transducers. The second report compared the sensitivity of PVDF transducers with polypropylene electrostatic transducer designs. Further work performed to determine optimum charging conditions for high sensitivity and repeatability of electrostatic responses was described in the third report.

The present report briefly describes the work performed over the entire project and then describes, in detail, the development and piezoelectric characterization of a flexible composite material which may be used for acoustic emission monitoring applications.

UNCLASSIFIED

SECURITY CLASSIFICATION OF THIS PAGE(When Data Entered)

REPRODUCTION PROHIBITED

Title: PIEZOELECTRIC AND ELECTROSTATIC POLYMERIC
TRANSDUCERS FOR ACOUSTIC EMISSION DETECTION

Fourth and Final Periodic Report

Principal Investigator: Dr. D. K. Das-Gupta

Associate Investigator: Dr. K. Doughty



ERO Contract No. DAJA45-83C-0008

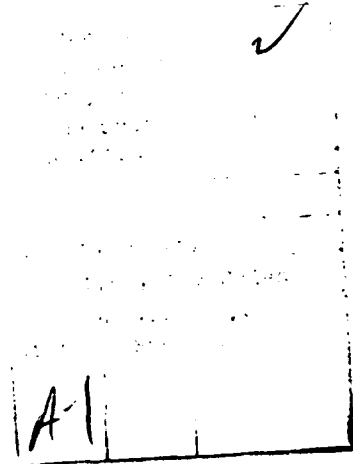

School of Electronic Engineering
Science,
University College of North Wales,
Dean Street,
Bangor, Gwynedd. LL57 1UT
Great Britain

December 1984.

85 02 25 108

- 1 -

Summary

→ The work performed during the contractual period falls into three distinct parts:-

- i) the fabrication of ultrasonic transducers for acoustic emission ~~(A.E.)~~ detection using polyvinylidene fluoride (PVDF) active elements.
- ii) the fabrication of electrostatic transducers using thin films of non-polar polymers such as polypropylene and polytetrafluoroethylene.
- iii) the development of a flexible composite material with piezoelectric properties using powdered ceramic (PZT) dispersed in a polymer matrix.

The first period report dealt with the design and characterization of PVDF transducers. The second report compared the sensitivity of PVDF transducers with polypropylene electrostatic transducer designs. Further work performed to determine optimum charging conditions for high sensitivity and repeatability of electrostatic responses was described in the third report.

^{This}
~~The present~~ report briefly describes the work performed over the entire project and then describes, in detail, the development and piezoelectric characterization of a flexible composite material which may be used for acoustic emission monitoring applications. ←

Review

The Mark III A.E. transducer which had been developed under ERO Contract No. DAJA 37-81-C-0021 (see final report of that contract for details) was tested and compared with a new PVDF transducer which had only one evaporated electrode. The new technique used in this design relied on an earthed conducting sample to provide the second contact and a thin layer of oil was used to produce good mechanical

coupling. It was found that the 'one-electrode transducer' was superior to the Mark III transducer for the detection of Rayleigh Waves in aluminium, but the reverse was true for composite insulating materials on which a thin layer of aluminium had first to be applied for electrical contacting.

A PVDF ring transducer was also produced and it was found that it was capable of detecting events occurring within a volume defined by its outer diameter. Maximum response, with minimum noise, was found for events occurring in line with the central (unelectroded) region. It was concluded that coupling of transducer to test material was one of the greatest sources of poor response using these transducers.

Attempts were made to improve coupling by applying a bias field to the element in order to stick it to the test surface by electrostatic attraction. However, the response enhancement was found to be < 5% even with a 500 volt bias across a 25 μm thick sample. The test procedure enabled comparison to be made of the performances of the PVDF transducers and those of electrostatic transducers produced by the corona charging of polypropylene films.

It was found that the sensitivity of the electrostatic transducer matched that of PVDF designs if a bias potential of a few hundred volts was applied. It was also shown that the frequency responses of both polypropylene and PVDF transducers were basically flat in the range 100 KHz to 2 MHz making them ideal for wide-band acoustic emission monitoring.

Electrostatic transducers were also fabricated from other materials including polytetrafluoroethylene (PTFE) and FEP/TFE copolymer in order to determine the best combination of material, polarization process, and bias voltage to produce good coupling, high

sensitivity and repeatability without deterioration of response with time, temperature, humidity etc. It was found that PTFE electrets were difficult to polarize effectively at temperatures $< 120^{\circ}\text{C}$ whilst FEP/TFE electrets produced inconsistent results but good linearity with bias field.

It was concluded that there was considerable scope for further work into the development of electrostatic transducers but that such work might take several man-years, requiring a comprehensive study of charge trapping and detrapping in a wide range of polymers.

We considered it necessary to investigate briefly the possibility of introducing a third class of transducer material ie. the piezo-composites, before deciding which type of material was best for acoustic emission monitoring in plastic composites.

Much of the work described in the first, second and third periodic reports have been used to form the basis of a review article on the use of electro-active polymers in acoustic emission monitoring. A copy of this publication is attached at the end of this report. Also attached is a published article describing the parametric considerations necessary to produce maximum piezoelectricity from PVDF transducers.

PIEZO-COMPOSITES

Introduction

The advantages of piezo-composites over ceramics are that they are tougher, lighter, more flexible, more processable, have lower sound velocities, lower acoustic impedances and are capable of more efficient coupling to non-flat surfaces. They also have a distinct advantage over the piezoelectric polymer polyvinylidene fluoride in that their electromechanical coupling efficiency is likely to be considerably higher. Also, they are readily poled in thicknesses greater than 100 μm which is not the case for PVDF.

The preparation of the piezo-composite is in three parts:-

- i) mixing the component phases
- ii) fabricating a film of the composite material
- iii) polarizing the film to render it piezoelectric.

(i) Mixing

Ceramic powders of PZT-5 are available with or without a wax binding additive from Unilator Technical Ceramic Ltd., of Ruabon, Great Britain. The method of incorporating the powder into the polymer matrix depends on the type and form of the polymer. If this polymer is of the thermosetting variety, such as the polyester family, then the powder is easily mixed during the polymerisation stage while the polymer components are still liquid. The polymer is then formed in a suitable mould by curing at an appropriate temperature ($\sim 70^{\circ}\text{C}$) for a few hours after which time it will have set into the polymerised state. In order to prevent separation of the dense powder from the lighter polymer, the mould has to be rotated slowly during the curing stage.

Thermoplastics such as polyethylene, polypropylene, polyvinylidene fluoride etc. are available in pellet form. These pellets can be melted and pressed or rolled, extruded or milled in the molten state, regaining their plastic properties when recooled. A filler such as ceramic powder may be introduced during the melting process simply by adding it gradually as the plastic is milled.

Many thermoplastics may be dissolved in organic solvents such as acetone, toluene or xylene at suitable temperatures, and then cast as films on slides or in moulds. This process enables the easy mixing of a powder and also allows a liquid plasticizer to be introduced in order that the final composite is more flexible. The mixture is heated in an oven to about 120°C in order to remove the solvent and to fuse the polymer fully.

(ii) Fabrication of Films

Thermosetting composites have to be set in moulds which set limits to the minimum achievable thickness. In our experiments using a flexible polyester (Scott Bader 390) we were able to obtain defect-free samples not thinner than 1 m.m.. These could further be ground to about 500 µm thickness but the resulting platelets were found to be brittle.

A milled composite can either be scraped directly off the rollers as a random shaped lump, or, by gradually cooling the rollers and decreasing their separation, it can be removed as a milled hide of thickness 200 - 400 µm. A thinner film, limited by the powder particle size, can then be pressed between metal plates at a pressure of a few tons at a temperature about 20°C below the melting point of the host polymer. Similarly, composites prepared from a solvent solution can be pressed as above, though lower pressures and

temperatures are generally required due to the effects of solvent and/or plasticizer.

(iii) Polarizing the Films

Corona charging has proved to be ineffective in poling composite films at room temperature. Therefore, only the thermal poling technique has been used on the samples described below. Generally, a temperature of 100°C was used for poling, as recommended by the PZT manufacturers, though this was reduced to 90°C in samples containing a plasticizing agent.

The polyester composite was capable of withstanding temperatures considerably above the limit of our charging apparatus (150°C) but the surface properties of our samples was so defective that no surface potential above 100 volts could be maintained either in silicon oil or in dry nitrogen. Hence, it was not possible to polarize the polyester composite prepared above.

The maximum field/temperature parameters that could be applied to the other films without breakdown was dependent on thickness and PZT content. 250 μm thick film containing 50% PZT by volume in PVDF, polypropylene or polystyrene could withstand a field of 10^7 Vm^{-1} for an hour. The composite film with PVDF was found to be most flexible and hence the properties of this material, with and without a plasticizer (di-methyl phthalate) are described in the following section.

Piezoelectric Properties of PVDF/PZT Composites

In the present work we have measured the dielectric, piezoelectric and ageing properties of a milled composite of PVDF and a composite prepared from solvent with added plasticizer.

(i) Dielectric Properties

The low frequency (10^{-3} - 10^{-1} Hz) dielectric behaviour has been obtained from an analysis of charging and discharging currents following the step-wise application and removal of a d.c. voltage. Charging currents decayed for about 100 secs. before approaching a quasi-steady state conduction level dependent on temperature and field.

Isochronal charging currents are presented in Figure 1 for the respective composite materials with and without plasticiser at 15 and at 55°C, as a function of applied voltage. The behaviour of current with field becomes super-linear for fields $> 4 \times 10^6$ Vm⁻¹ as dipolar orientation begins to occur.

The low frequency loss behaviour of the same two materials at these temperatures is shown in Figure 2. These data were obtained by Hamon approximations using discharge current transients. They indicate the presence of a loss peak in the 1 Hz region at 15°C and interfacial polarization at a very low frequency ($< 10^{-3}$ Hz) at 55°C.

The presence of the plasticizer has a pronounced effect on the dielectric constant of the composite. Figure 3 shows the frequency dependence of ϵ' without the plasticizer whilst Figure 4 shows it with plasticizers at two temperatures. These differences are mirrored in the corresponding loss behaviour shown in Figure 5.

(ii) Piezoelectric Properties

In the present work we have not attempted to study the temperature variation of the piezoelectricity in these composites. However, it is to be expected that this will be similar to the respective behaviour of dielectric constant. We have determined the d_{31} piezoelectric coefficient by measuring the charge released by a sample strip when a known mass was suspended from its end. At 20°C, d_{31} of the unplasticized

sample was found to be -19.5 pCN^{-1} and -24 pCN^{-1} for the plasticized case. The hydrostatic coefficient d_n ($\approx d_{33}$) was found to be 40 pCN^{-1} for the sample without plasticizer and 50 pCN^{-1} for the sample with plasticizer. Piezoelectric resonance techniques were used to find the electromechanical coupling factors. For the unplasticized sample K_{31} was -5% and K_t ($\approx K_{33}$) was 10% while K_{31} was -6% and K_t was 12.5% for the sample with plasticizer.

(iii) Ageing

The stability of the piezoelectricity was tested by exposing the poled films to a 50Hz a.c. field of increasing magnitude for 10^3 second at 15°C at each voltage and measuring the value of d_{31} at the end of each test period. It was found that the film suffered dielectric breakdown at 4KV . (RMS) before any noticeable reduction in d_{31} could be observed. Hence, the piezoelectricity of the film was shown to be extremely stable at room temperature.

At elevated temperatures, the stability was tested by annealing the film for 15 hours at an increasing temperature and measuring d_{31} at the end of each period. It was found that neither type of film lost more than 10% of its activity below 90°C . The normalised data is shown in Figure 6.

Conclusions

We have shown that piezoelectric composite films can be prepared from PZT powder and a fluoro-polymer such as PVDF in a small laboratory without specialist equipment. The composite materials obtained in this way can be poled to provide greater electro-activity than piezoelectric PVDF whilst maintaining a degree of flexibility suitable for applications in a hostile environment. The degree of flexibility can be increased by the addition of plasticizer but at the expense of stable dielectric properties with temperature and frequency.

We are now designing sensing devices based on this flexible piezo-composite.

Fig. 1. Field effect of 100 s charging current in composite materials.

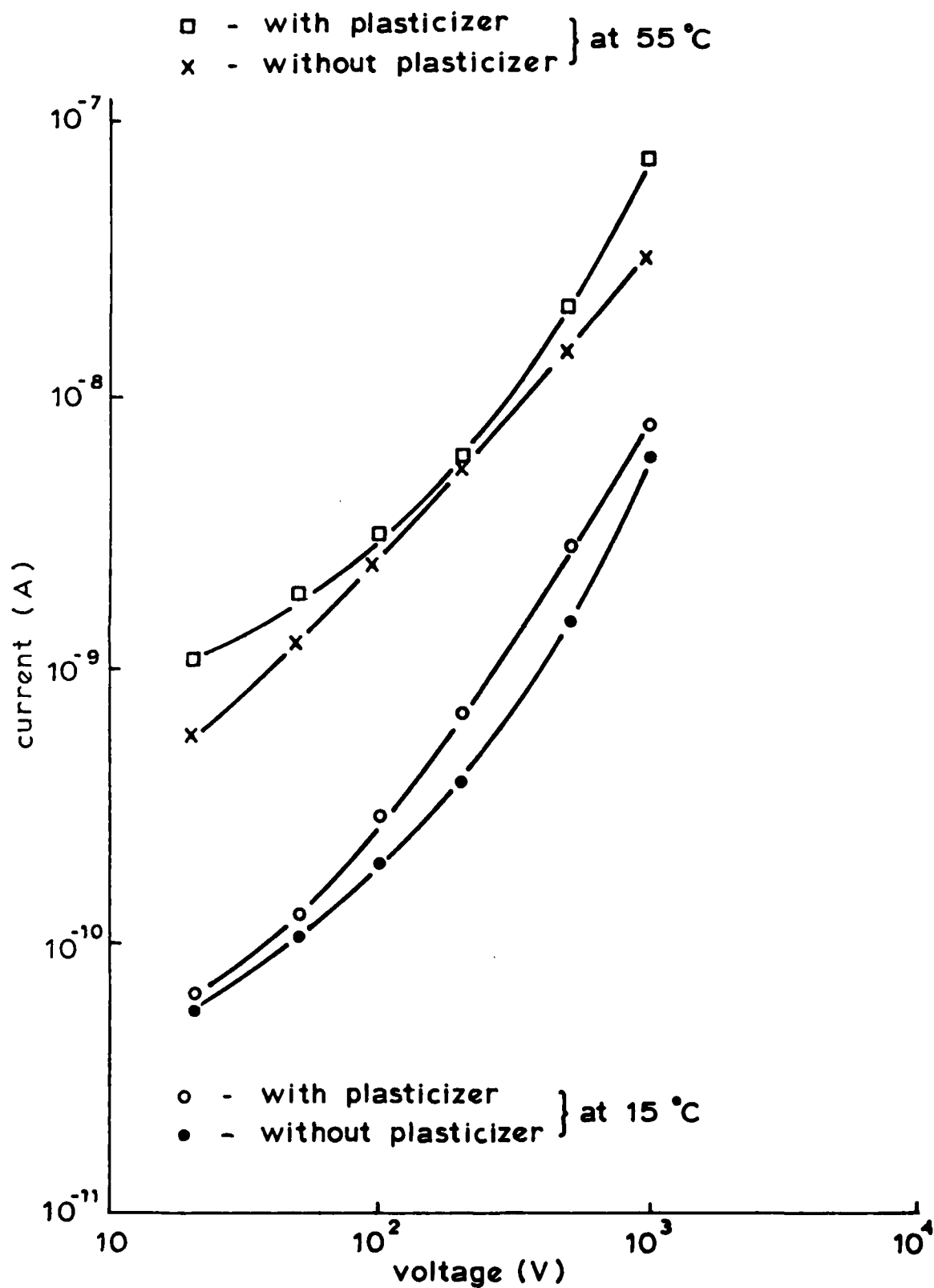

Fig. 2 . Low frequency loss behaviour of composite film.

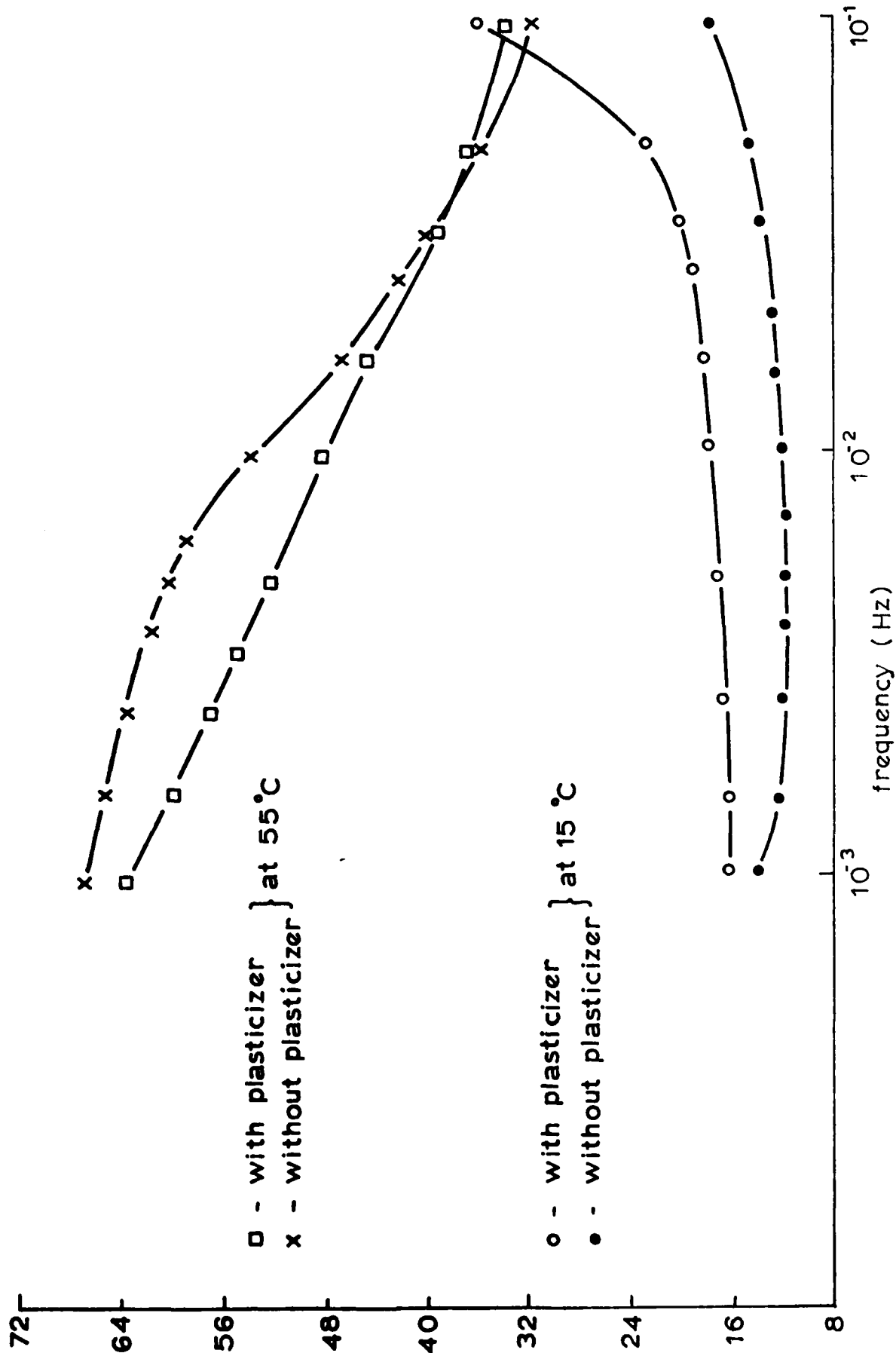

Fig. 3. Frequency dependence of ϵ' in composite film without plasticizer.

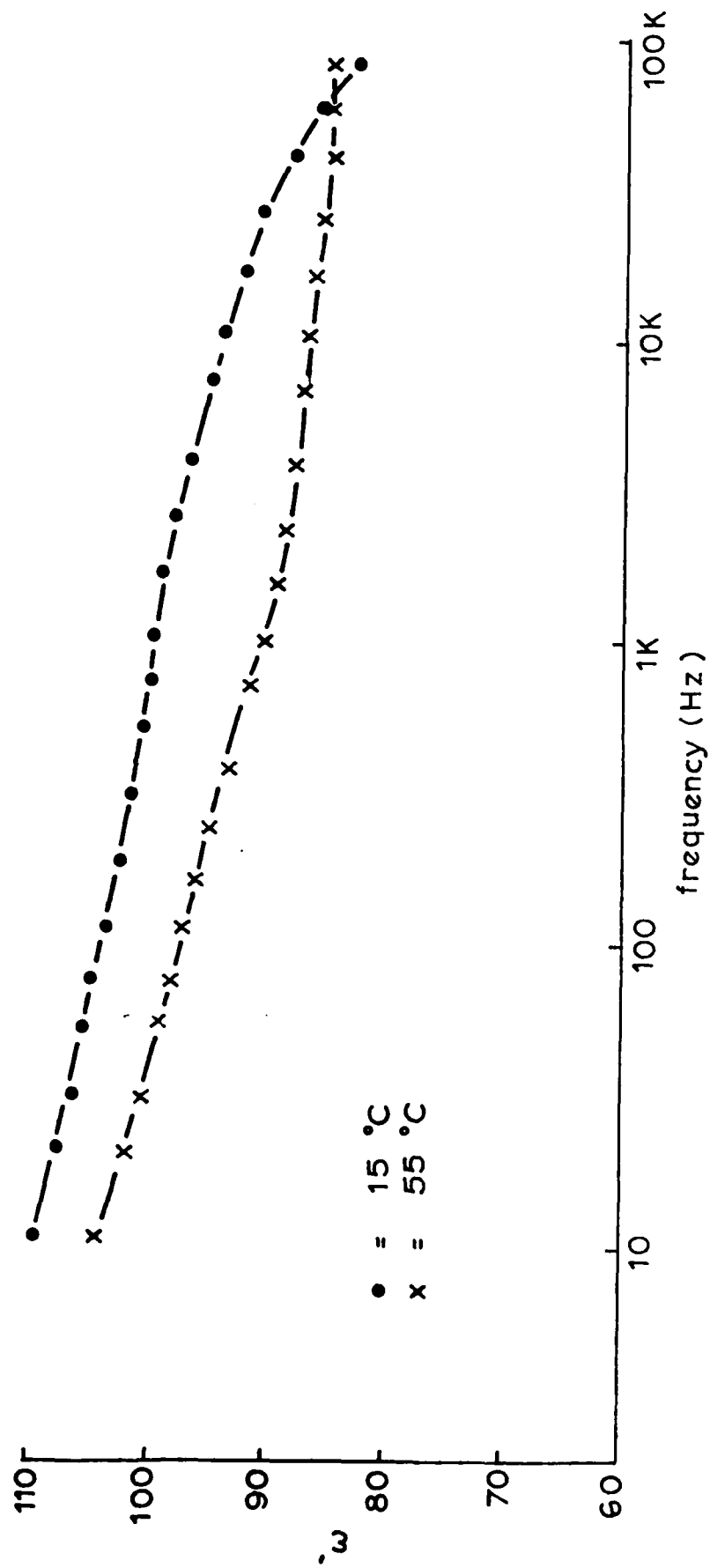

Fig. 4. Frequency dependence of ϵ' in composite film with plasticizer.

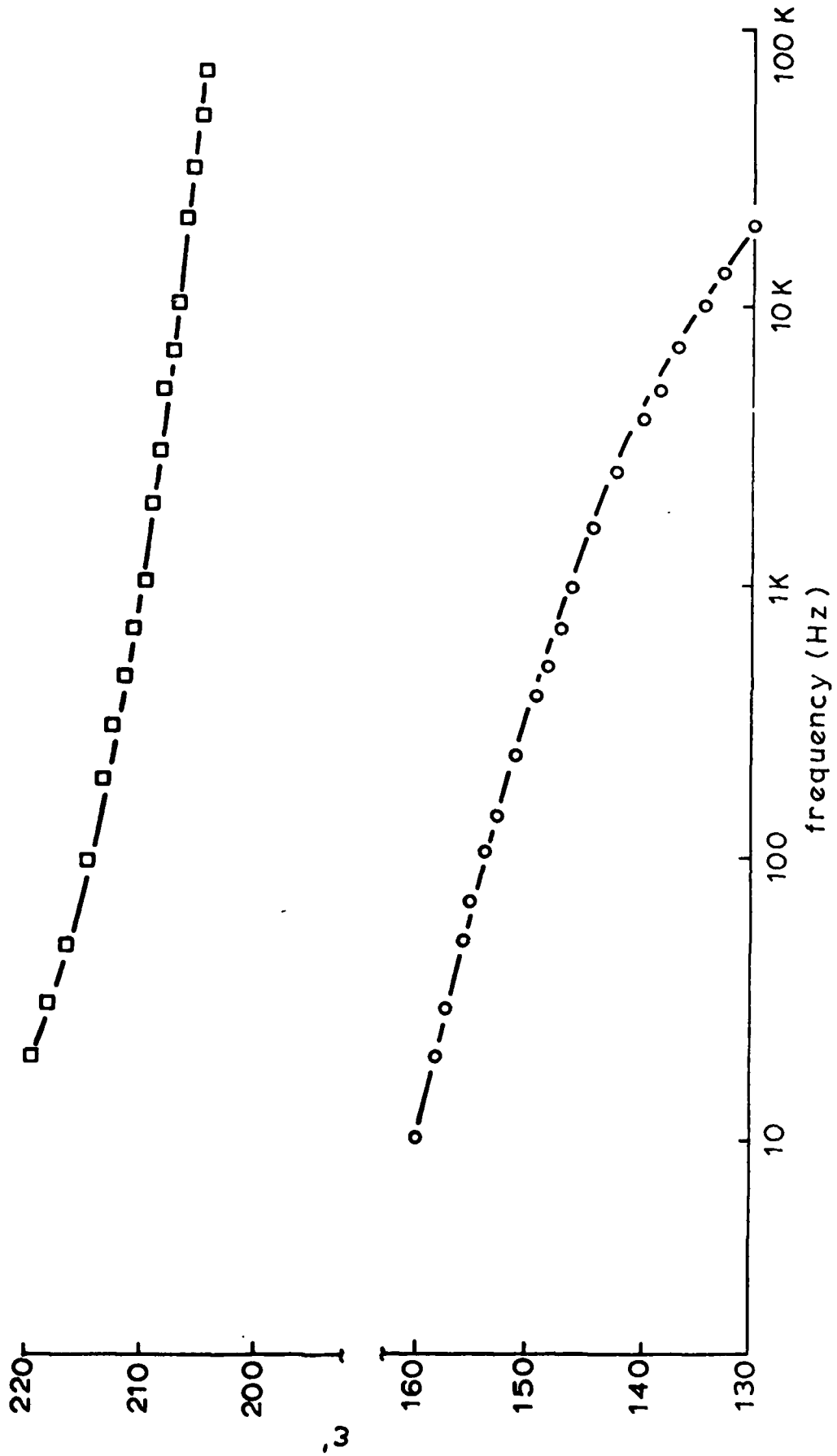

Fig. 5. Frequency dependence of ϵ' in composite materials.

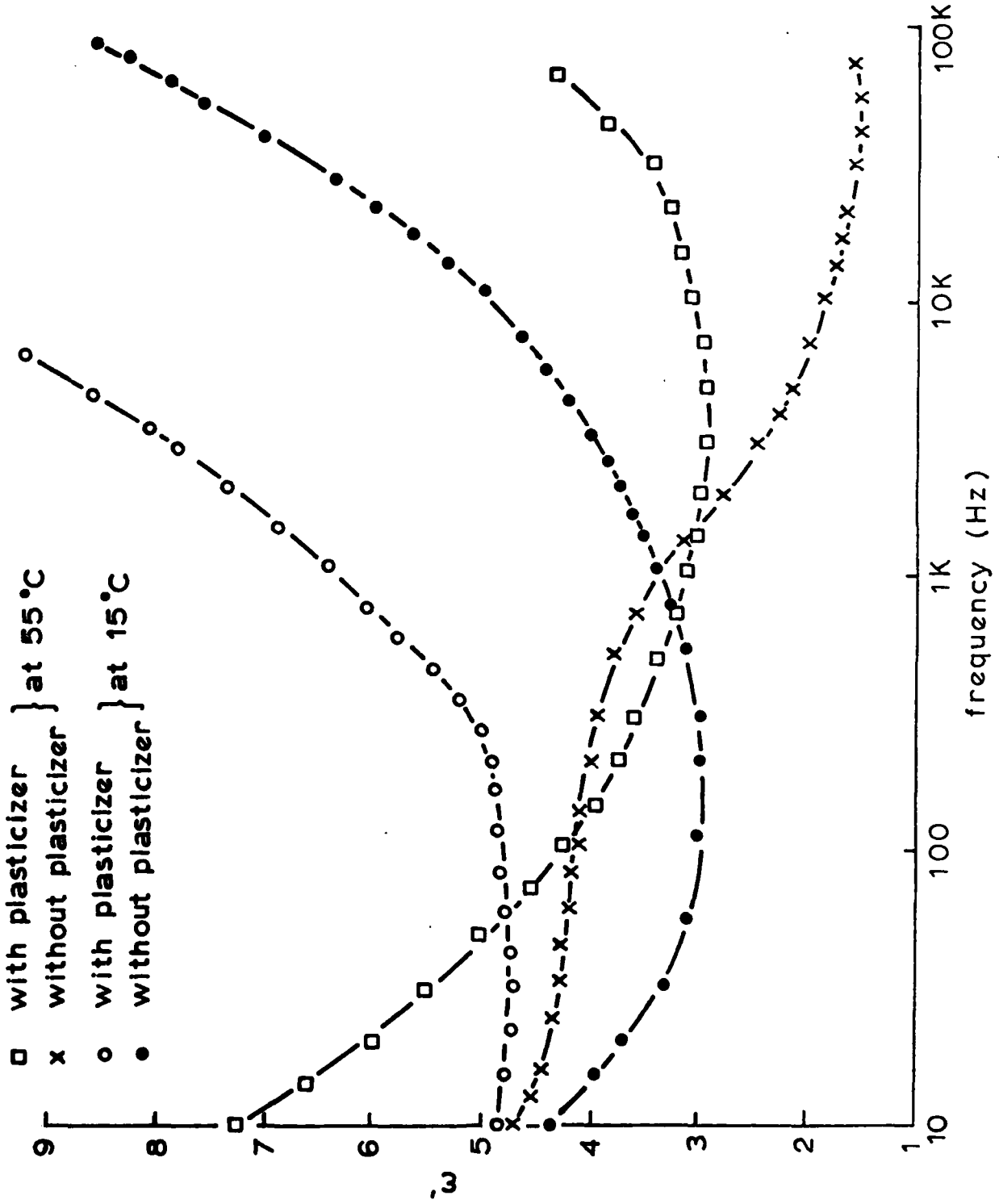
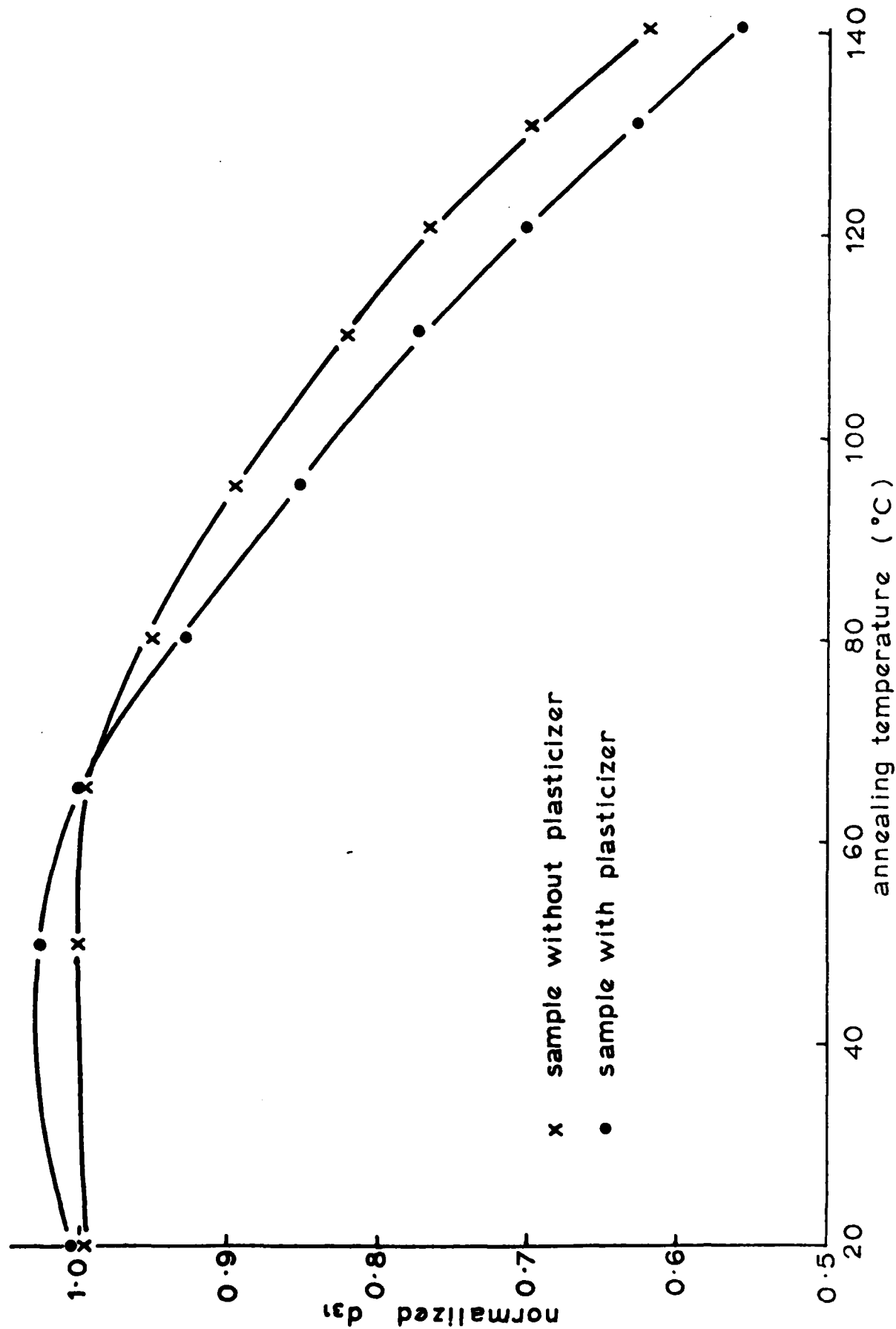

Fig. 6. Thermal ageing of piezoelectricity in composite materials.



To be published in the February 1985
Journal of IEEE Transactions on Electrical Insulation.

ELECTRO-ACTIVE POLYMERS IN NON-DESTRUCTIVE DIELECTRIC EVALUATION

D. K. Das-Gupta and K. Doughty

School of Electronic Engineering Science
University College of North Wales
Dean Street, Bangor, U.K.

ABSTRACT

The piezoelectric nature and acoustic coupling constant K_{33} of corona-poled polyvinylidene fluoride (PVF₂) have been investigated as a function of frequency extending in the MHz region, using different techniques. The frequency response of an electrostatic transducer using corona-poled polypropylene film (PP), as the sensing element, has also been studied and compared with that of corona-poled piezoelectric PVF₂ film. The sensitivity and frequency response of piezoelectric PVF₂ transducer appear to be comparable to those of electrostatic transducer using polypropylene and employing a large bias field.

INTRODUCTION

The purpose of this paper is to outline the experience gained in an evaluation of the acoustic properties dielectric films, polyvinylidene fluoride (PVF₂) and polypropylene (PP) which may be used as piezoelectric and electrostatic transducer for non destructive testing (NDT), i.e., detection of acoustic emission (AE) in materials under stress.

AE is generated during the growth of cracks in materials under stress and has been used to monitor the behavior of flaws both under laboratory conditions and, more recently, in large engineering structures. This technique can be applied to most classes of construction materials [1] including concrete and metals, as well as the plastic composites which are now being employed extensively for load-bearing structures. Ideally an AE transducer should offer both high sensitivity and a flat bandwidth over at least three decades of frequency. Conventional piezoelectric transducers, using brittle ceramic elements, are not ideally suited to measurements on plastics and their composites due to the coupling problem and a large impedance mismatch. A more satisfactory solution might involve the use of thin films of polymers such as PVF₂ and PP which may be rendered electroactive by inducing a long-lived polarization by an application of a high poling field (conventional or corona poling). A field-induced polarization may originate from several complex mechanisms including an orientation of structural dipoles and injection of electrical charges and their subsequent localization in semicrystalline polymers. The mechanical strength of a polymer film, together with its flexibility, reasonably uniform electroactive response over a wide frequency range, and the magnitude of its acoustic impedance, makes it useful for the detection

of AE signals in plastics and composites although its electroactive response may be significantly lower than those of ceramic materials.

Present work describes the acoustic characterization of corona-charged PVF₂ and PP transducers suitable for ultrasonic application over a wide band of frequencies, extending into the MHz range. Corona charging to fields $>10^8$ Vm⁻¹ produces piezoelectric activity in PVF₂ due to a rotation of crystalline axes [2,3], whereas similar treatment of PP films produces considerable charge storage (electrostatic case) in the polymer.

PIEZOELECTRIC TRANSDUCER

The piezoelectricity in poled PVF₂ is due to the pressure dependence of field-induced polarization in the crystalline phase [4]. Therefore, a stress or strain on the film will change the film volume and hence the dipole moment per unit volume. This will result in the production of charges on the film faces which are usually coated with vacuum-deposited metal such as aluminum. AE will produce perturbations in the thickness direction of the film and hence in a variation of charge density dependent on the coupling of the transducer to the test medium, the magnitude of the pressure wave and the piezoelectric d -coefficient in the thickness direction (i.e. d_{33}) of the film. If the response is measured as a voltage, then the sensitivity will be proportional to the thickness of the film, assuming that the lead capacitance is negligible.

Bui et al. [5] have developed a theoretical model (one-dimensional) of a lossy resonator which may be applicable to unsupported PVF₂ films (poled) with electrodes on both sides. In this model the lateral

dimensions of a resonator which may be made to vibrate in its acoustic modes, are assumed to be large in comparison with its thickness and acoustic wavelength. The electrode layers are assumed to be acoustically thin so as not to load the transducer, and their effect is only slight reduction of resonant frequency in the thickness mode.

The electrical behavior of a piezoelectric free resonator may be characterized [5,6] by an electrical circuit (Fig. 1) consisting of a static total electrode capacitance C_0 in series with a resistive component R_0 , accounting for the dielectric loss, an acoustic reactance X_a and an acoustic loss resistance R_a . It may be shown that the acoustic loss (or quality) factor Q is given by [5]

$$\frac{X_a}{R_a} = 2Q \frac{\sin\theta}{\theta + \sin\theta} = -2Q\delta \quad (1)$$

where the frequency is normalized

$$\theta = \omega/\omega_0 \quad (2)$$

and ω_0 is the resonance frequency which is defined by the frequency at which the maximum of R_a (i.e. \hat{R}_a) occurs and

$$\delta = \frac{\sin\theta}{\theta + \sin\theta} \quad (3)$$

Thus Q may be conveniently determined from a knowledge of R_a and X_a , Q being equal to half the slope of a plot of X_a/R_a against frequency near the resonance frequency. It may be noted that the electromechanical coupling factor $K_{33}^2 (=K_t^2)$ is also related to Q thus [5],

$$K_{33}^2 = \frac{\pi}{\delta} \frac{\omega_0 C_0 \hat{R}_a}{Q} \quad (4)$$

Thus a knowledge of the behavior of R_a and X_a with frequency together with the values of ω_0 and C_0 should provide an acoustic characterization of a lossy piezoelectric resonator such as electroded PVF₂.

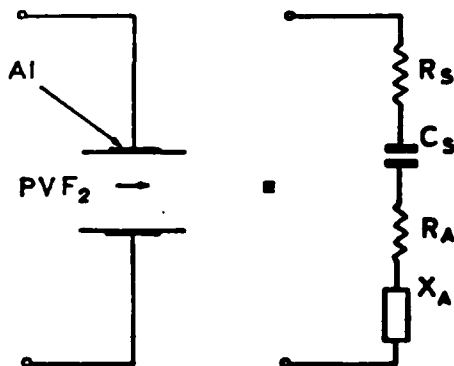

Fig. 1: Electrical equivalent circuit of PVF₂ as a piezoelectric resonator

However, a complex situation may arise when the coupling of the poled PVF₂ transducer film to a dense medium is considered, especially at high frequencies. The straightforward static capacitance of PVF₂ is now shunted by a radiation resistance which is a function of the backing and the load material of the film. In general, their effects will lead to a significant increase in the insertion loss which, in the case of a material with a low value of coupling factor, will render the material significantly less effective for transducer purposes unless the losses are minimized. In the case of PVF₂, this effectively means matching the acoustic impedance of the polymer to the test material in such a manner that no lossy air gaps can exist. This may be achieved by using only one evaporated electrode on the polymer film and employing the metallic surface of a test material as the ground electrode, coupled with a drop of suitable oil. Alternatively, an electrostatic attraction may be employed to adhere the non-metallized film surface to the grounded metallic test surface as in the case of an electrostatic transducer. Numerous applications of poled PVF₂ piezoelectric films have been extensively reviewed [4,7-9].

ELECTROSTATIC TRANSDUCER

An electrostatic transducer relies on a relative movement between two electrodes to produce a change in capacitance, thereby generating a signal in the external circuit. Simple electrostatic transducers [10] use air as dielectric but lack sensitivity and there are difficulties in maintaining a very small electrode separation in normal use. More sensitive devices [11] use a dielectric medium, such as PP (which may be corona charged), to increase the capacitance and provide an internal field by its charge storage properties. This is the basis of an electret microphone and requires that one face of the film be metallized to serve as a flexible electrode, while the other electrode is relatively fixed. In an AE monitoring system the latter electrode would be the material under test, which means that it can only be used on conducting surfaces, although this problem can usually be overcome by evaporating a thin layer of metal (~50 nm) on the insulator surface. Sensitivity can be improved by employing an external bias field to supplement the internal field of the transducer film [12]. The direction of the bias field needs to be opposite to that of the original electrification of the dielectric film in order that an appropriate superposition of fields may occur. It may be shown [13,14] that the efficiency of an electrostatic transducer (ig. 2) K , is given by

$$K = \frac{V + \sigma_1 d_1 / \epsilon_0 \epsilon_r}{d_1 + (d_2 / \epsilon_0 \epsilon_r) + d_2} \quad (5)$$

which is linear with both the bias voltage V and the charge density σ_1 on the central dielectric film surface adjacent to layer 1 (Fig. 2). d_1 and d_2 represent the distances of separation between the dielectric film and the upper lower electrodes respectively and d_2 is the thickness of the dielectric film. ϵ_0 and ϵ_r are the permittivity of free space and the relative permittivity of the transducer film respectively. The bias voltage applied to produce maximum efficiency, also serves to adhere the film to the test block (i.e., lower electrode, Fig. 2). However, since the bias field opposes the internal field of the dielectric film, care should be taken to ensure that a neutralization does not occur. In practice, this means that the maximum bias voltage is limited to values which do not

produce large conduction effects. In good insulating polymers, such as PP and Fluoroethylene propylene (FEP), several hundred V may be applied without depolarizing the film.

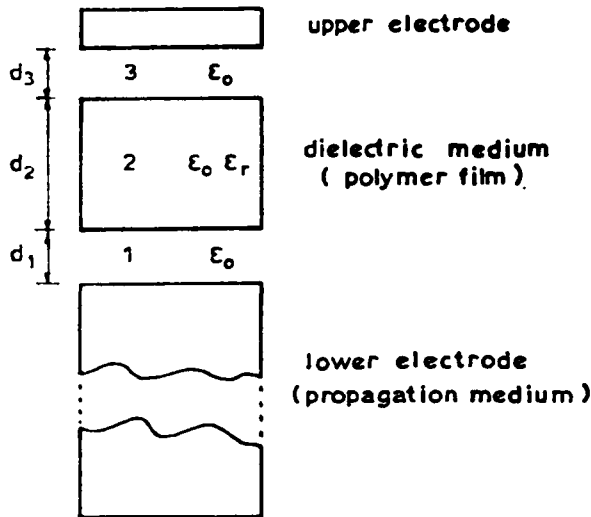

Fig. 2: Representation of an electrostatic transducer

EXPERIMENTAL

PVF₂ films used in this work were kindly provided by the Kureha Chemical Industries Company of Japan and were of 25 and 50 μm thicknesses. Polypropylene films of 30 μm thickness were obtained with the generosity of Hercules Powder Company, U.S.A. Film surfaces were carefully cleaned with isopropanol and corona poling was employed using a technique described elsewhere [15], the maximum poling field being 4×10⁸ Vm⁻¹. The poling was usually done at room temperature for 1 minute.

The electromechanical coupling coefficient K_{33}^2 of the corona poled PVF₂ films was measured using the piezoelectric resonance technique due to Bui et al. [5] which involved measurements of capacitance C and conductance G of an unloaded resonator over a range of frequencies centered at the fundamental thickness mode resonance and determining the acoustic resistance R_a and acoustic reactance X_a of an equivalent series resonance circuit. These measurements were made with Wayne-Kerr VHF impedance bridge extending to a frequency of 100 MHz.

Unfortunately, this method suffers from the disadvantage that it is applicable only at one frequency, i.e. the thickness mode resonance frequency, and this renders it unsuitable for determining the behavior of K_{33}^2 over a wide frequency range. For this reason K_{33} has also been measured [16] in the present work using a simple method due to Dameron and Linvill [17] which involves exciting a poled film with a voltage and then detecting the transmitted signal as an induced voltage on an identically poled film, the two active elements being separated by an impedance matched acoustic delay element. Fig. 3 shows the experimental arrangement in

which the films were mounted on 5 cm diameter brass discs of 5 mm thickness to provide a high impedance backing to minimize energy loss through the metallic backing medium. The films were held rigidly in position by a brass annular ring which also served to make the ground contact to the top electrode. The two corona-poled films were separated from each other by a delay element consisting of an unpoled and unelectroded PVF₂ film of 130 μm thickness.

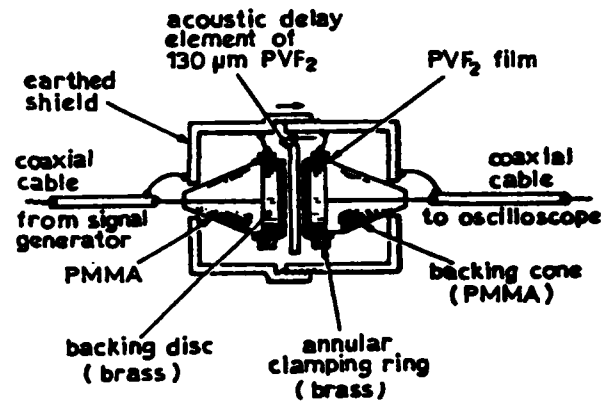

Fig. 3: Schematic diagram for the measurement of electro-mechanical coupling factor K_{33}

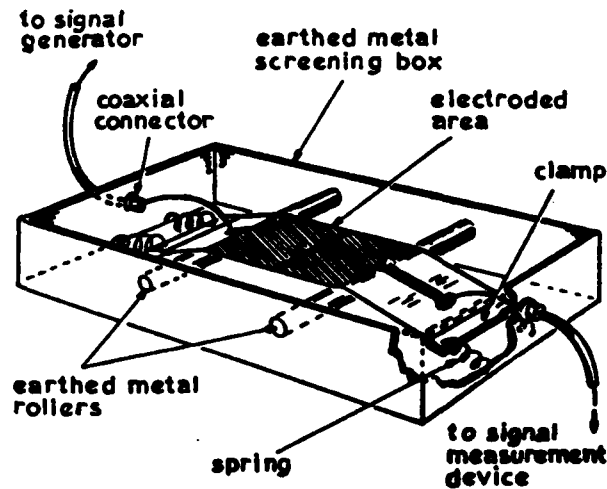

Fig. 4: Schematic arrangement of measurement of piezoelectric response d_{31}

Measurements of the piezoelectric strain constant d_{31} , were also carried out [16] in this work with PVF₂ using an all electrical method due to Rosvams and Linvill [18]. The experimental arrangement is as shown in Fig. 4. The top electrodes (vacuum deposited) were split into two equal halves, generally of length 6 cm and width 1.2 cm, separated by a gap of 2 mm.

bottom electrode was continuous over the entire length of the entire film under investigation. The plate was then located over two grounded aluminum layers which make electrical contact to the bottom electrode, and was held taut with clamp and spring arrangements [16]. An application of a voltage to one of the top electrode will induce a proportional output voltage due to the piezoelectric property of poled film at the other top electrode. In the present work this output voltage has been measured for constant input of 20 V over the frequency range of Hz to 1 MHz.

The experimental arrangement for testing the acoustic response of electrostatic transducer is shown [16] in Fig. 5. A corona-charged polypropylene film with only evaporated aluminum electrode was attached to a 1/8 inch thick block of polished aluminum with the electrode side outermost. An electrical contact was made to the electrode face of the film by a small wire soldered with silver-loaded epoxy. The transducer film is in the direct acoustic field of an ultrasonic transducer driven at a resonant frequency of 43 kHz. The front electrode of the polymer was connected to a coupled oscilloscope via a HV supply. A decoupling coil is necessary between the HV supply and the oscilloscope to prevent signal losses through the supply. The HV supply was used to provide a bias potential to obtain good sensitivity. Similar measurements were made with corona poled PVF₂ films of 25 μm thickness. To compare the wideband frequency responses of the two transducers (i.e. PVF₂ and PP), an arrangement, shown in Fig. 6, was employed in which a noise spectrum is produced by a corona spark technique. It is assumed that high frequency acoustic waves covering a bandwidth of several MHz are produced by such a technique and that they will travel through the aluminum block. A spectrum analyzer was used to record the output of both the PVF₂ and PP electrostatic transducers as a function of frequency.

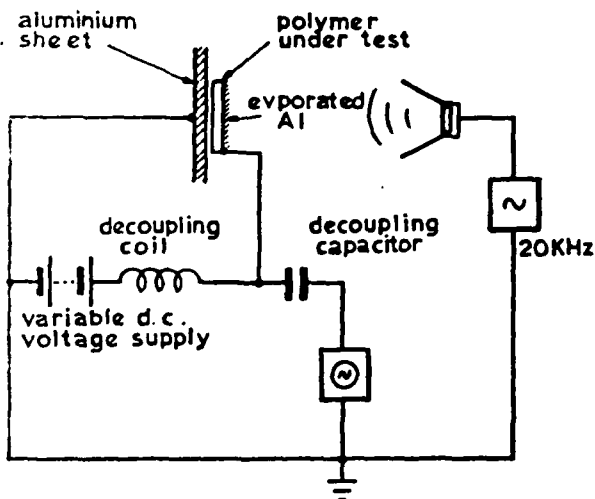

Fig. 5: Experimental arrangement for electrostatic transducer testing

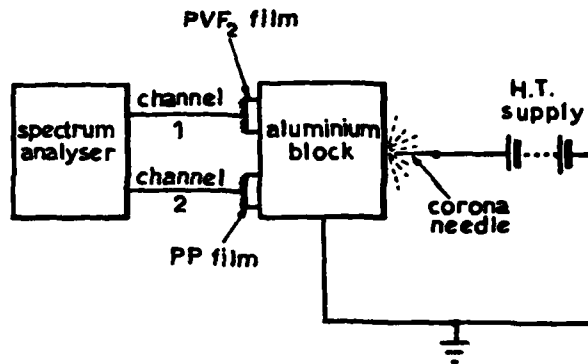

Fig. 6: Experimental arrangement for comparison of wideband response of electrostatic and piezoelectric transducers

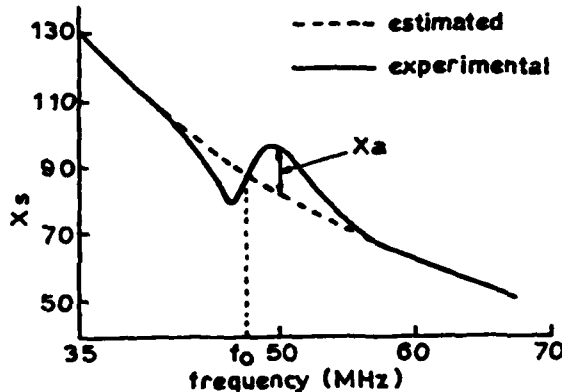

Fig. 7: Behavior of X_s with frequency for 25 μF thick, corona poled ($+ 4 \times 10^8 \text{ Vm}^{-1}$) PVF₂

RESULTS AND DISCUSSION

From the measured values of capacitance and conductance with the VHF impedance bridge X_s and R_s were calculated for the piezoelectric PVF₂ films at different frequencies. It should be noted that X_s and R_s are not purely the acoustic reactance X_a and acoustic resistance R_a , as they include the reactance and resistance of the electrodes and the connecting wires. A straightforward way of removing these unwanted factors is to use a graphical method. From Figs. 7 and 8 it may be observed that the plots of X_s and R_s against frequency are smooth except at values close to the resonance frequency. A smooth curve was drawn through the points and then a second line was drawn which estimated the shape the curve would take if the sample was not piezoelectric. From the differences between these two curves a set of results were derived for X_a and R_a .

The acoustic loss factor was then obtained from the slope of the plot of X_a/R_a against normalized frequency (Fig. 9). Fig. 10 shows a similar plot for 50 μm thick PVF₂, corona poled at the same field as for 25 μm thick PVF₂. The acoustic loss factor Q , determined from the slopes of Figs. 8 and 9 are 10.85 and 10

for the 25 μm thick poled PVF₂ films, respectively, which are not too dissimilar from those obtained by Bui et al. [5] who used a vector impedance bridge in their work. The piezoelectric coupling factor K_{33}^2 is defined as the ratio of electrical energy at the output to the total input mechanical energy and is given by Eq. 4. Using the determined values of the total electrode capacitance C_0 , the K_{33}^2 values for 25 and 50 μm PVF₂ TE resonators were found to be 0.0157 and 0.0204 respectively [20] which are in good agreement with Bui et al. [5] but lower than those obtained by Ohigashi [19]. The latter author, however, used uniaxially stretched films whereas in the present work the films were biaxially oriented. Furthermore, it is established that positive corona charging, which was employed in the present work, produces predominantly hydrated species such as H₂O⁺, H₃O⁺, and N₂H⁺. During the poling process if some of these ions were injected in the film, the profile of the field-induced internal polarization will be different from that due to a conventional poling at an elevated temperature. Perhaps it may be stated that negative corona charging produces predominantly O⁻ ions by dissociative electron attachment and less commonly CO₃⁻ ions. It has been shown [21] that no detectable difference in the piezo- and electroelectric properties have been observed between the positive and negative corona poling PVF₂ at room temperature. Table 1 summarizes the acoustic parameters of PVF₂ film measured near the resonant frequency, using the series equivalent circuit due to Bui et al. [5] which are in good agreement with these workers.

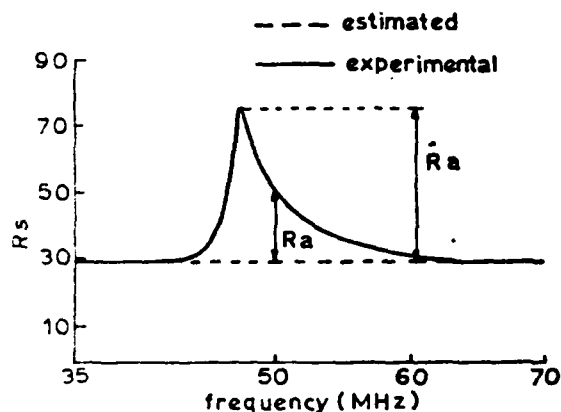

Fig. 8: Behavior of R_s with frequency for 25 μm thick, corona poled ($+4 \times 10^8 \text{ Vm}^{-1}$) PVF₂

It has been stated earlier that resonator models of Bui et al. [5] applies strictly near the resonance frequency and alternative methods [17,18] have also been employed in the present work to measure d_{31} and K_{33}^2 over a wide frequency range [16]. Typical frequency response curves of 50 μm thick, poled and unpoled PVF₂ films, obtained with Rezvani and Linvill [18] method (Fig. 4) are shown in Fig. 11 [16]. It may be observed that the response of the poled sample increases gradually with frequency from 10 Hz to 5 MHz with two dominant peaks at 13 and 70 kHz which may originate from the excitation of standing waves along the length (6 cm) and width (1.2 cm) respectively. Assuming that the resonance condition occurs at a value of $\lambda/2$ of the linear

dimensions, where λ is the wavelength, the corresponding values of the velocity of sound in PVF₂ appear to be 1560 ms^{-1} and 1680 ms^{-1} respectively. These values are lower than those reported in the literature [5], but may still be reasonable as the acoustic velocity is known to decrease with frequency [22] in PVF₂. The piezoelectric coefficient d_{31} may be calculated from such a response (Fig. 11) using the following expression [18],

$$d_{31} = \frac{2 V_2}{V_1} \cdot \frac{C_T}{C_E} \quad (6)$$

where V_1 and V_2 are the input and output voltages respectively ($V_1 \gg V_2$), C_T is the permittivity of the film under constant stress and C_E is the Young's modulus under constant field. No experimental determination of the Young's modulus has been made in this work and a value of $3.6 \times 10^6 \text{ N m}^{-2}$ for C_E , used by Rezvani and Linvill [18] have also been employed here to determine d_{31} . The observed values of d_{31} (Fig. 10) are considerably higher than the largest reported value of $40 \times 10^{-12} \text{ C N}^{-1}$, obtained by corona poling during stretching of the PVF₂ film [23]. This implies that the value of Young's modulus, stated above, is too small and indeed this would appear to be the case as observed by Wang et al. [24] from their work with Brillouin scattering with uniaxially stretched PVF₂ films. These authors suggest that an increase in Young's modulus may result from an orientation of the polymer in the amorphous and the crystalline phases of the polymer. PVF₂ films, used in this work, were biaxially stretched although the stretch ratio remains unknown.

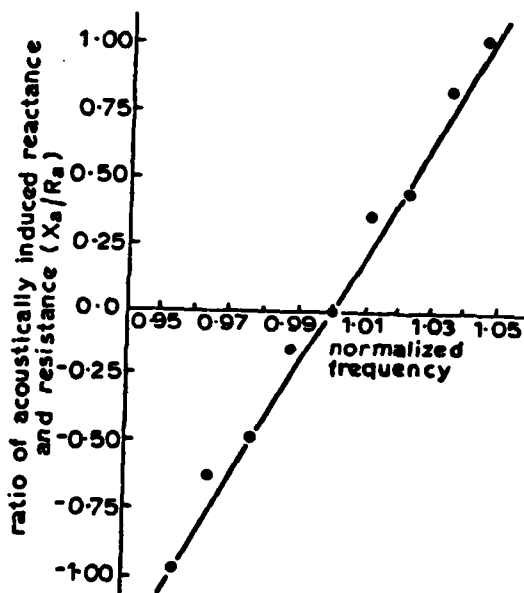

Fig. 9: Behavior of X_a/R_a with normalized frequency for 25 μm thick, corona poled ($+6 \times 10^8 \text{ Vm}^{-1}$) PVF₂

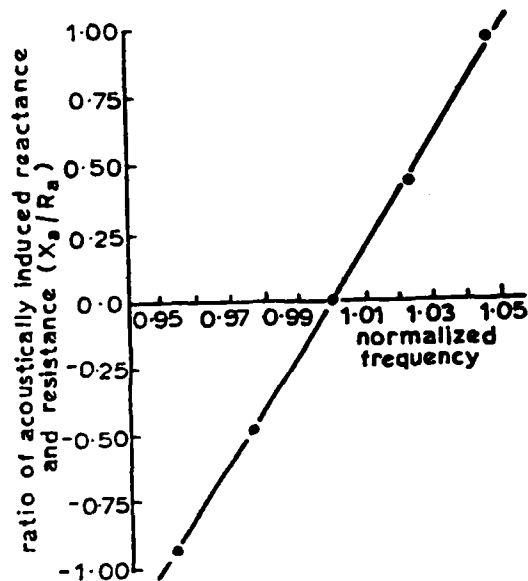

Fig. 10: Behavior of X_a/R_a with normalized frequency for 50 μm thick, corona poled ($+ 3 \times 10^8 \text{ Vm}^{-1}$) PVF₂

Table 1

Measured Acoustic Properties of PVF₂ Film

| File thickness (μm) | 25 | 50 |
|--|--|--|
| Corona poling conditions | $4 \times 10^8 \text{ Vm}^{-1}$ (i.e. 10KV) at room temperature for one minute | $3 \times 10^8 \text{ Vm}^{-1}$ (i.e. 15KV) at room temperature for one minute |
| Resonance frequency in the thickness mode | 43.5 MHz | 21.3 MHz |
| Unloaded acoustic loss factor Q | 10.8 ± 1 | 10 ± 1 |
| Electromechanical coupling constant K_{33} | 12.32 | 14.32 |
| Electrode capacitance | $9 \times 10^{-12} \text{ F}$ | $20 \times 10^{-12} \text{ F}$ |

Fig. 12 shows the frequency response of poled PVF₂ using the method due to Dameron and Linvillé [17] both for a continuous sine wave and for a pulsed train of sine waves [16]. The frequency response appears to be reasonably constant over the frequency range employed in the present work except for the peaks at 15 and 30 kHz which correspond to $\lambda/2$ and λ standing wave conditions across the film surface. The reduction in peak amplitudes with a pulsed sine wave may be explained by less energy being available for the formation of standing waves. The origin of other minor responses are probably related to reflections from the outer casing. In the present method [17], the electromechanical coupling constant K_{33} may be obtained from the following expressions,

$$K_{33} = \frac{2}{1 - \alpha(V_1/V_2)} \quad (7)$$

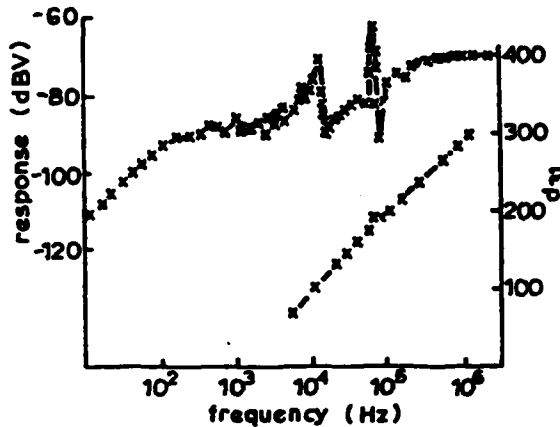

Fig. 11: Frequency response of corona poled and unpoled PVF₂ together with K_{33} values

where V_1 is the input energizing voltage (in the transmitting element), V_2 is the induced voltage in the receiving element and α is the loss of signal resulting from transmission through the delay element. The value of K_{33} , obtained in this work with the method due to Bui et al. [5], was 0.143 for 50 μm thick PVF₂ case. From Eq. 7 it may be observed that for $K_{33} < 0.2$, $1 - \alpha(V_1/V_2) > 10$ which implies that $\alpha(V_1/V_2) \gg 1$.

$$K_{33} = \frac{-2 V_2}{\alpha V_1} \quad (8)$$

Therefore, for a constant input voltage and acoustic loss through the delay element, K_{33} is directly proportional to V_2 . The negative sign of K_{33} reflects the negative values of the piezoelectric coefficient d_{33} . The comparatively flat nature of the frequency response (Fig. 12) suggests little variation in K_{33} with frequency under loaded conditions. Assuming that K_{33} measured at ~ 43 MHz by the method due to Bui et al. [5] is the same as that at 5 MHz, the value of α appears to be 7×10^{-4} [16] which compares well with an acoustic absorption of 11×10^{-4} [17].

With the help of the above results PVF₂ transducers (piezoelectric) have been fabricated and their performances are being investigated for the detection of AE signals. The results will be reported in due course.

Fig. 13 shows the typical bias voltage characteristics of polypropylene (PP) electrostatic transducer at 43 kHz. It may be observed that the response of the PP transducer is highly dependent on the bias voltage, doubling for $+ 500 \text{ V}$ bias. By cycling the bias fields, between $\pm 600 \text{ V}$, the addition and subtraction of internal and external fields can be observed clearly and the internal field may be estimated to be in the range of 100 to 200 V in a negative direction. A saturation of polypropylene transducer response is observed at $+ 600 \text{ V}$. No attempt was made to employ higher bias fields in order not to depolarize the internal field. A commercial loudspeaker was also employed as a source

10 and 20 kHz. The results were qualitatively similar to those shown in Fig. 13 except that the actual responses were dependent on the acoustic power delivered at each frequency. Measurements were also made at 86 kHz using an ultrasonic generator and, once more, the form of the results was as shown in Fig. 13 which so shows the response of a PVF₂ (piezoelectric) transducer of 25 μm thickness, energized in an identical manner (see Fig. 3). At zero bias voltage, the PVF₂ transducer appears to produce a greater signal, but this signal is little affected by a bias potential in either direction. For both materials the cycled response returns to the same position at 0 V bias showing the excellent reproducibility of the results. Measurements were also taken with 50 μm thick samples of PVF₂ and PP. In this case the charging potential of 15 kV, which produced a similar field to that used with the 25 μm thick samples. However, in both cases, the recorded signals were within 10% of those recorded with the 25 μm thick samples. Although it is possible that the respective piezoelectric coefficients or injected charge densities are not simply related to the field and that the thicker films do not act as well for transducing, it is more likely that most of the signals are lost due to various insertion loss factors which do not show such significant thickness dependences. For this reason, it is suggested that thin films may be more suitable for electrostatic transducers. It also emphasizes the need to eliminate the various loss mechanisms when employing PVF₂ as active element in an electrostatic transducer.

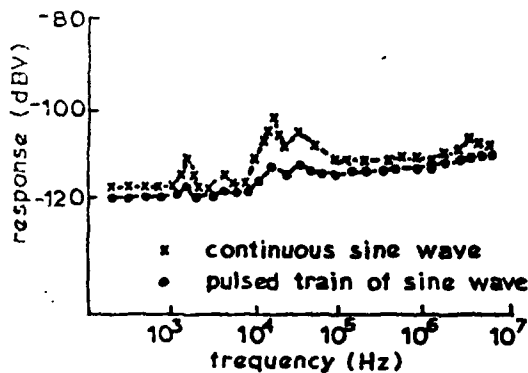

Fig. 12: Frequency response of corona poled PVF₂ obtained with Dameron and Linville method [17]

It may also be stated that for the case of electrostatic transducers when the upper electrode (see Fig. 6) is vacuum deposited, then $d_1 = 0$. Also $d_3 < d_2$, and if $\epsilon_1 d_3 < d_2$ then it may be observed from Eq. 5 that the maximum sensitivity depends on the use of a dielectric medium which can maintain the highest charge density σ_1 , bias field and relative permittivity ϵ_r . These characteristics may be difficult to find in one material because high relative permittivity usually implies large dipole moments which produce dielectric loss processes not only under dc stress but also as a function of frequency. Thus, such a material would neither trap charges effectively over long periods of time nor would it exhibit a flat frequency response. Thus a

compromise must be made between the demands of high permittivity and of large trapped charge density close to one surface. In general, non-polar polymers are ideal materials for electrostatic transducer application because they are excellent insulators even in thin film forms, having high dielectric breakdown strength and long-lived space charge polarization following high field charging.

Fig. 15 shows the response of 30 μm thick electrostatic polypropylene transducer as a function of both positive and negative corona charging potentials. It is significant to note that saturation occurs for charging potentials in the range of 10 to 12 kV for both polarities of the corona poling. However, negatively charged samples give greater zero bias sensitivities and also greater responses at 600 V bias. It may be assumed that it is easier to inject negative charges into polypropylene than positive charges and that the electron traps are also shallow in this material. Thermal poling was found to produce samples with a high sensitivity at zero bias field but bias voltages were only capable of increasing the response by 70 to 80% compared to the 200% possible with corona poling. It is possible that a greater percentage increase in the response of an electrostatic transducer could be achieved by using very thin films of a high dielectric strength non-polar polymer.

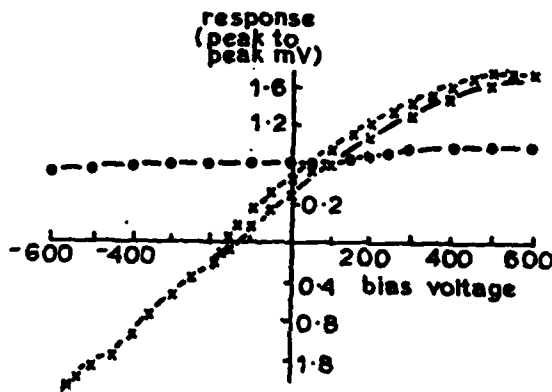

Fig. 15: Effect of bias voltage on response of PVF₂ and PP electrostatic transducers at 63 kHz
 x polypropylene film (electrostatic)
 o polyvinylidene fluoride film

Finally, wideband frequency responses of the electrostatic (PP) and the piezoelectric transducers were obtained using the experimental arrangements of Fig. 6. It may be observed from Fig. 15 that both transducers produce a flat response curve to 2 MHz, which makes them ideal for wideband applications including AE monitoring. Further work is in progress for studying the acoustic properties of polymer-ceramic composites in which ceramic materials have been incorporated in the polymer matrix in order to enhance the detection efficiency of the transducer.

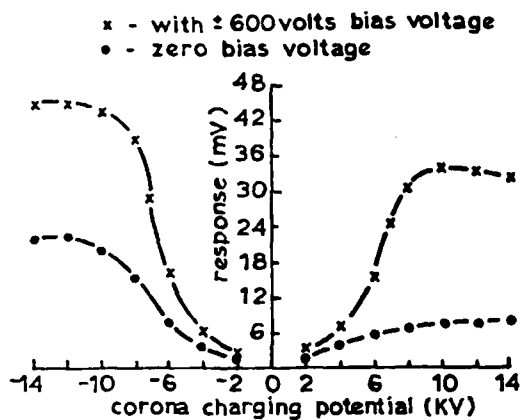

Fig. 14: Effect of corona charging potential and polarity on the response of polypropylene electrostatic transducer with and without bias voltage

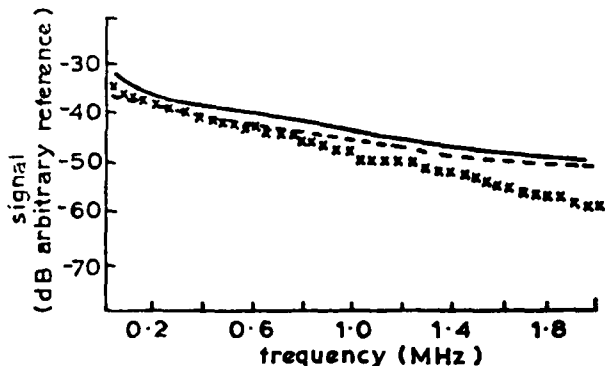

Fig. 15: Corona noise spectra of PVF₂ and PP transducers.

— polypropylene with 500 V bias
 xxx unbiased polypropylene
 ---- PVF₂ (unbiased)

ACKNOWLEDGMENT

This work has been supported by a research grant from the U.S. Army.

REFERENCES

[1] S. P. Ying, "Characteristics and Mechanisms of Acoustic Emission from Solids under Applied Stress" *CRC Crit. Rev. Solid St. Sci.*, **4**, 85-103 (1973).
 [2] D. K. Das-Gupta and K. Doughty, "Piezo- and Pyroelectric Behaviour of Corona-Charged Polyvinylidene-fluoride" *J. Phys. D.*, **11**, 2415-2423 (1978).
 [3] D. K. Das-Gupta and K. Doughty, "Piezoelectricity in Uniaxially Stretched and Corona Poled PVF₂" *J. Phys. D.*, **13**, 95-105 (1980).

[4] M. G. Broadhurst and G. T. Davies, "Topics in Applied Physics - Electrets", Ed. Sessler, G.M., Springer Verlag, **33**, 284-219 (1980).
 [5] Le N. Bui, H. J. Shaw and L. T. Ziteili, "Study of Acoustic Wave Resonance in Piezoelectric PVF₂ Film" *IEEE Trans. Sonics and Ultrasonics*, **SU-24**, 331-336 (1977).
 [6] P. Ravinet, J. Hue, G. Volluet, P. Hartmann, D. Brossoux and F. Micheron, "Acoustic and Dielectric Loss Processes in PVF₂" *IEEE Ultrasonic Symposium*, 1017-1021 (1980).
 [7] H. Sussner, "Piezoelectric Polymer PVF₂ and its Applications", *IEEE Ultrasonic Symp. Proc.*, 491-498 (1979).
 [8] G. M. Sessler, "Piezoelectricity in polyvinylidene-fluoride", *J. Acoust. Soc. Amer.*, **70**, 1596-1607 (1980).
 [9] G. M. Sessler, and J. E. West, "Topics in Applied Physics - Electrets" Ed. G. M. Sessler, Springer Verlag, **33**, 347-381 (1980).
 [10] C. B. Scruby and H. N. G. Wadley, "A Calibrated Capacitance Transducer for the Detection of Acoustic Emission" *J. Phys. D.*, **11**, 1478-1494 (1978).
 [11] G. J. Curtis, "A Broadband Polymeric Foil Transducer" *Ultrasonics*, July, 148-154 (1974).
 [12] G. M. Sessler and J. E. West, "Electret Transducers: A Review", *J. Acoust. Soc. Amer.*, **53**, 1589-1600 (1973).
 [13] D. Legros and J. Lewiner, "Electrostatic Ultrasonic Transducers and Their Utilization with Foil Electrets" *J. Acoust. Soc. Amer.*, **53**, 1663-1672 (1973).
 [14] D. Legros, J. Lewiner and P. Biquard, "Generation of Ultrasound by a Dielectric Transducer" *J. Acoust. Soc. Amer.*, **52**, 196-198 (1972).
 [15] D. K. Das-Gupta and K. Doughty, "Corona Charging and Piezoelectric Effect in Polyvinylidene-fluoride", *J. Appl. Phys.*, **49**, 4601-4603 (1978).
 [16] K. Doughty, D. K. Das-Gupta, R. J. Shuford and Y. Hinton, "Piezoelectric Polymers in Non-destructive Dielectric Evaluation" *Annual Report, IEEE Conference on Electrical Insulation and Dielectric Phenomena (CEIDP)*, 263-269 (1982).
 [17] D. Dameron and J. G. Linville, (Unpublished), Stanford University, USA (1978).
 [18] B. Rezvani and J. G. Linville, "Measurement of Piezoelectric Parameters versus Bias Field Strength in Polyvinylidene-fluoride (PVF₂)", *Appl. Phys. Lett.*, **34**, 828-830 (1979).
 [19] H. Ohigashi, "Electrochemical Properties of Polarized Polyvinylidene-fluoride as Studied by the Piezoelectric Resonance Method" *J. Appl. Phys.*, **47**, 949-955 (1976).

- [20] G. E. Dixon, Acoustic and Piezoelectric Properties of Polyvinylidene fluoride, M.Sc. Dissertation, University of Wales (1981).
- [21] K. Doughty, X-ray Diffraction Studies of PVF₂ Under Electrical Stress, Ph.D. Thesis, University of Wales (1978).
- [22] R. J. Shuford, A. F. Wilde, J. J. Ricca and G. R. Thomas, "Characterization and Piezoelectric Activity of Stretched and Poled PVF₂ Part 1: Effect of Draw Ratio and Poling Conditions" *Polym. Eng. & Sci.*, 16, 25-35 (1976).
- [23] T. Furukawa, T. Goro and M. Date, "Piezoelectricity in Corona Poled PVDF" *Kobunshi Ronbunshi*, 56, 685-689 (1979).
- [24] C. H. Wang, D. B. Cavanaugh and Y. Hasegaki, "Brillouin Scattering Studies of PVDF Films Subject to Uniaxial Stretching", *J. Polym. Sci., Polym. Phys. Ed.* 19, 941-950 (1981).

Manuscript was received 20 July 1984, in revised form 28 September 1984.

SOME PARAMETRIC CONSIDERATIONS FOR PIEZOELECTRIC SENSORS WITH POLYVINYLIDENE FLUORIDE FILMS

K. DOUGHTY AND D. K. DAS-GUPTA

School of Electronic Engineering, University College of North Wales, Dean Street, Bangor, Gwynedd LL57 1UT (Gt. Britain)

(Received August 2, 1983; accepted November 9, 1983)

An investigation has been made into the effect of a poling field on the piezoelectric response d_{31} of commercially available films of polyvinylidene fluoride of different thicknesses (6–130 μm). Other parameters such as the electrical breakdown field strength and variations in d_{31} with poling temperature have also been investigated.

1. INTRODUCTION

Commercially available films of polyvinylidene fluoride (PVF₂) are semicrystalline in nature, consisting of lamellar crystals and amorphous regions. There are two types of unit cell crystal structure^{1–8} in such films, *i.e.* a polar form 1 (or β form) and a non-polar form 2 (or α form). These films, when suitably stretched and poled, may exhibit significant piezoelectricity with d_{31} and d_{33} values of about 20×10^{-12} C N⁻¹ (refs. 9–11). Molecular conformational changes from form 2 to form 1 may occur in PVF₂ on uniaxial stretching^{11–14} without providing any net dipole moment as the crystallites are rotated at random rotational angles about the *c* axis (*i.e.* the carbon–carbon axis). The dipole moments can, however, be oriented favourably during the poling process subsequent to stretching. It is thus established that the preferential alignment of complete chains of polar crystalline molecules by the poling field provides the origin of at least a large part of the piezoelectric response in PVF₂^{15–20}. The piezoelectric frequency response of poled PVF₂ shows that the electromechanical coupling factor K_{33} (not greater than 0.2), and hence d_{33} , is uniform^{10,21–23} over a wide band extending into the megahertz region¹⁰. The acoustic loss factor Q , which is 2π multiplied by the ratio of the average energy stored to the loss per cycle, has a value of about 14²¹. The mechanical strength of PVF₂ film, together with its uniform electroacoustic properties over a wide frequency region, may have important practical applications in diverse fields such as the detection of acoustic emission in materials under mechanical stress^{24,25} and pre-breakdown phenomena in insulating materials under electrical stress²⁶.

X-ray diffraction and IR absorption studies show that the structural transformation from the non-polar form 2 crystallite into a polar form 1 crystallite on high field poling occurs in two stages^{15,27,28}. At fields of about 3×10^8 V m⁻¹ a

transformation of the non-polar monoclinic structure of the form 2 crystallites into an intermediate triclinic polar form 2 structure occurs by a cooperative rotation of alternate chains through 180° about the carbon-carbon axis. At still higher fields (greater than $3 \times 10^8 \text{ V m}^{-1}$) there is a progressive conversion of this intermediate polar form 2 structure into the polar form 1 structure with a zigzag molecular conformation. It is of interest to note that the saturation remanent polarization of a sample of PVF_2 containing both form 1 and form 2 crystallites may be higher than that of a sample containing only crystallites of the form 1 variety¹⁹. This indicates that the crystal form may not be the most significant factor in determining the usefulness of a particular film for device applications and the orientation of the polymer chains may ultimately govern the piezoelectric responses. Now the charge developed across the opposite faces of a piezoelectric film due to a mechanical stress is independent of thickness and depends on the appropriate piezoelectric coefficient. Thus the voltage developed across the faces of a piezoelectric capacitor, for a constant piezoelectric coefficient, is linearly proportional to the film thickness. The requirement for a wide band piezoelectric sensing element is then a well-poled thick PVF_2 film.

The present work is a report of the results of an investigation of the piezoelectric responses obtained with corona-poled PVF_2 films of different thicknesses which were kindly provided by the Kureha Chemical Industries Company Limited of Japan. X-ray diffraction patterns of the structural planes have also been investigated for well-poled samples. An attempt has been made to discuss the parametric considerations which may be relevant to the production of piezoelectric PVF_2 sensors which may be useful for wide band applications.

2. EXPERIMENTAL DETAILS

The films employed in this work were all cut from commercially available rolls of nominal thickness 6, 9, 12, 16, 25, 50 or 130 μm . These fall into two categories: thin films (6–25 μm) and thick films (50–130 μm). The thin films are biaxially oriented so that they contain crystallites of both form 1 and form 2 whereas the thicker films are basically unoriented with a spherulitic structure¹⁷ containing only form 2 crystallites. X-ray diffraction studies show that the crystallinity, the ratio of the form 1 to the form 2 contents and the orientation of all the thin films do not vary with film thickness. The two thicker films were also found to be similar to one another with respect to structural properties.

For the above reasons, most of the experimental work described here will relate to samples 25 and 50 μm thick, which are representative of the two film classes and which have been used most extensively by other workers both for device applications and for fundamental research.

Conventional poling was performed in air, inside a temperature-controlled oven, with cooling to ambient temperature in the presence of the field. Corona charging was performed using the technique described elsewhere^{9,15,17,29}.

The piezoelectric coefficient d_{31} of the poled films was determined from measurements of charges which were produced when a known weight suspended from a sample was released by a pneumatically operated solenoid valve. The magnitude of the released charge was determined by measuring the peak voltage

developed across a large air capacitor connected in parallel with the PVF_2 sample under investigation¹⁵.

X-ray diffraction profiles were recorded before and after corona charging using the reflection diffractometer technique²⁰ and nickel-filtered $\text{Cu K}\alpha$ radiation. The evaporated layer of aluminium served as a useful internal standard to adjust Bragg angle data for any slight sample movement in the sample holder.

Capacitance measurements were performed using a General Radio capacitance bridge (model 1616) from 10 Hz to 100 kHz and two Wayne Kerr bridges (models B660 and B210) to extend the range up to a maximum frequency of 100 MHz.

3. RESULTS AND DISCUSSION

The observed behaviour of d_{31} with poling temperature (conventional poling) for each film thickness is shown in Fig. 1. The curves for each film thickness are of similar form, increasing almost linearly with poling temperature so that the coefficients obtained by poling at 120°C are about an order of magnitude greater than those obtained at 20°C .

The results fall into three distinct groups.

(1) For the samples 6 and $9\ \mu\text{m}$ thick d_{31} reaches a maximum value of about $3 \times 10^{-12}\ \text{C N}^{-1}$.

(2) For the samples 12, 16 and $25\ \mu\text{m}$ thick the piezoelectric coefficients are almost double those of the thinner films, reaching maximum values of about $5 \times 10^{-12}\ \text{C N}^{-1}$. The coefficients generally increase with increasing film thickness.

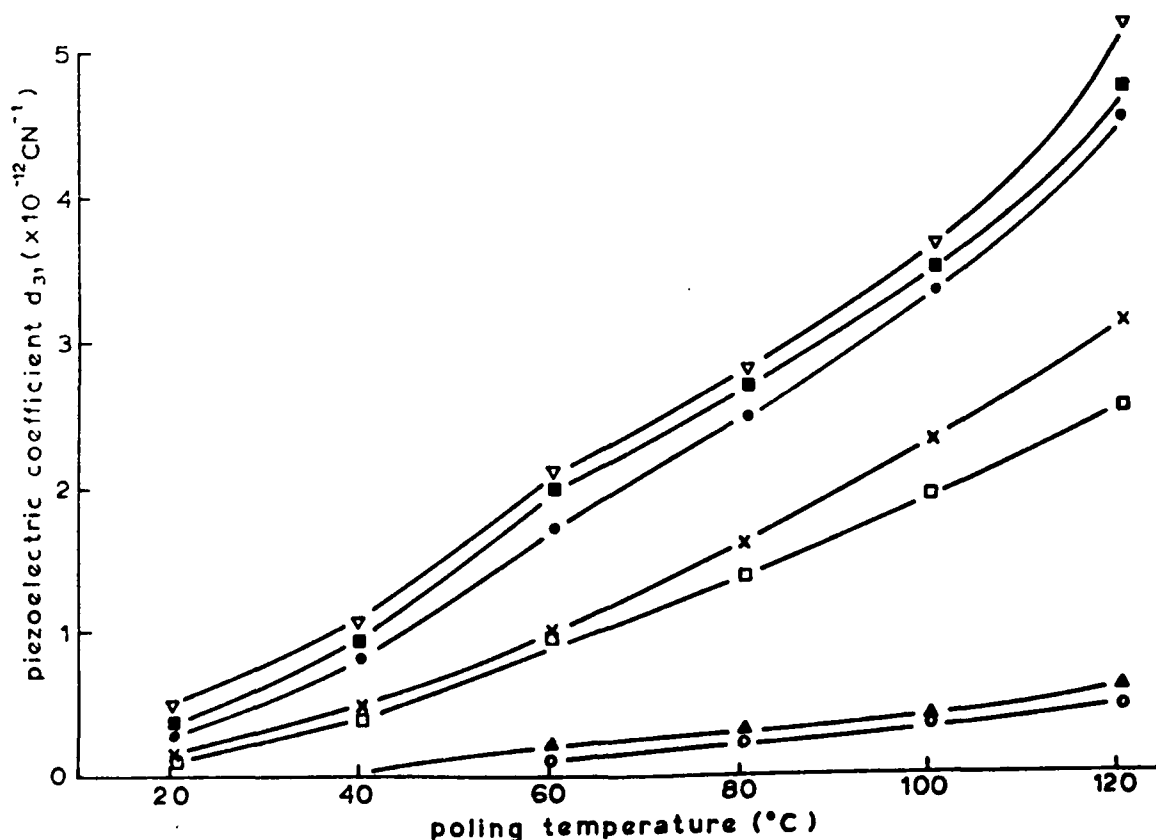

Fig. 1. Effect of poling temperature on the d_{31} coefficient of conventionally poled films of PVF_2 of various thicknesses (poling field, $5 \times 10^7\ \text{V m}^{-1}$; poling time, 30 min): □, 6 μm ; ×, 9 μm ; ●, 12 μm ; ■, 16 μm ; ▽, 25 μm ; ○, 50 μm ; ▲, 130 μm .

(3) For the samples 50 and 130 μm thick no piezoelectric activity can be observed at poling temperatures below 60°C with an applied field of $5 \times 10^7 \text{ V m}^{-1}$. Even at a poling temperature of 120°C , $d_{31} < 10^{-12} \text{ C N}^{-1}$.

It is not surprising that the samples 50 and 130 μm thick give lower coefficients than the thinner films, since they lack orientation and form 1 crystallites. However, it is not possible to invoke similar arguments to explain the apparent differences between the two thinnest films (6 and 9 μm) and the other films (12, 16 and 25 μm). It appears probable that either these films are slightly thicker than their nominal thicknesses, in which case the applied field was lower than that intended, or the stiffness of the aluminium becomes appreciable for very thin samples and distorts the actual stress felt by the sample. It is established²³ that electrode stiffness affects electrical measurements of Young's modulus and, in a similar manner, it may affect the values of d_{31} . The observed thickness dependence supports such a conclusion, although errors in film thickness cannot be excluded.

Figure 2 shows the observed behaviour of the piezoelectric coefficients of films 25 and 50 μm thick as a function of the corona poling field at room temperature. The experimental curves for both the film thicknesses have a similar profile corresponding to a large increase in d_{31} ($6 \times 10^{-12} \text{ C N}^{-1}$) over a relatively small increase in field ($1 \times 10^8 \text{ V m}^{-1}$). It has been shown by X-ray diffraction studies that this corresponds to a rotation of alternate chains of the form 2 crystallites through 90° in opposite directions to produce the intermediate polar form 2 crystallites^{15,20,27,28}, as mentioned earlier. The onset of piezoelectric behaviour is observed to occur at a lower poling field for the sample 25 μm thick (Fig. 2) which suggests that either the biaxial stretching has induced an alignment of the carbon-carbon axis in the surface plane, thereby aiding rotation about this axis in an applied field, or the internal field

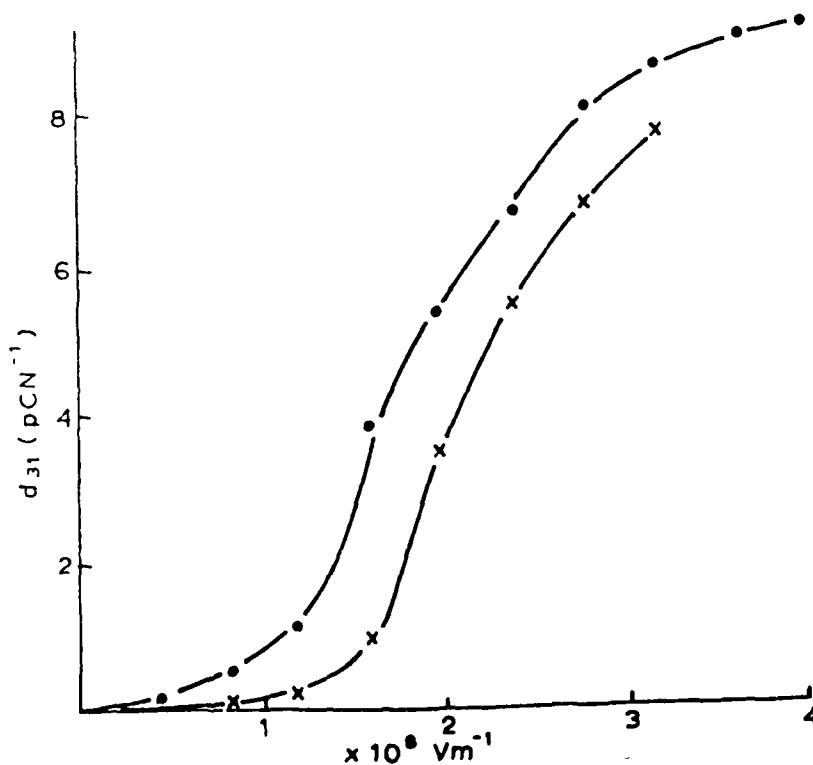

Fig. 2. Piezoelectric coefficient d_{31} of PVF_2 films (●, 25 μm thick; x, 50 μm thick) as a function of corona charging field (samples corona charged at 20°C for 1 min).

generated by the form 1 crystallites of the film 25 μm thick aids the formation of the intermediate polar form 2 crystallites during the process of poling. Increases in the value of d_{31} above $7 \times 10^{-12} \text{ C N}^{-1}$ are only achieved with larger increases in the poling and are considered to be associated with a conversion of the polar form 2 *trans-gauche-trans-gauche* molecules into the polar form 1 zigzag molecules^{10,15,27,28}.

The maximum corona poling voltage that can be applied for 1 min before an electrical breakdown occurs in a film of PVF_2 is shown in Fig. 3. As expected, the thickest film has the highest breakdown voltage, but with respect to the electric field (Fig. 3) it may be observed that the thickest film has the lowest electrical breakdown strength. It may also be observed from Fig. 2 that the film 25 μm thick containing both form 1 and form 2 crystallites appears to have the highest breakdown strength (about $5 \times 10^8 \text{ V m}^{-1}$). It is possible that, as the films are stretched more and more to produce still thinner samples, voids and defects are introduced³⁰, resulting in a reduction in the breakdown strength of the film. Although films charged with higher fields than those shown in Fig. 2 will suffer dielectric breakdown within 1 min, it is possible to employ much higher fields for a matter of seconds, achieving significant piezoelectric activity²⁰. Even if minor breakdown does occur, it is often possible to cut away the affected part and to use the remainder of the film for piezoelectric and X-ray diffraction measurements. In the present work piezoelectric studies have been restricted to films of 25 and 50 μm thickness which produce the best responses for the poling fields which can be applied by corona charging. The X-ray diffraction profile of a film 50 μm thick which suffered an electrical breakdown after 1 min of high field poling at ambient temperature is shown in Fig. 4. The evidence of the two-step process of structural changes of the non-polar form 2 crystallites into their polar variation and subsequently into the polar form 1 structure on poling, as discussed above, may be observed in Fig. 4. These changes are indicated (i) by the decreases in

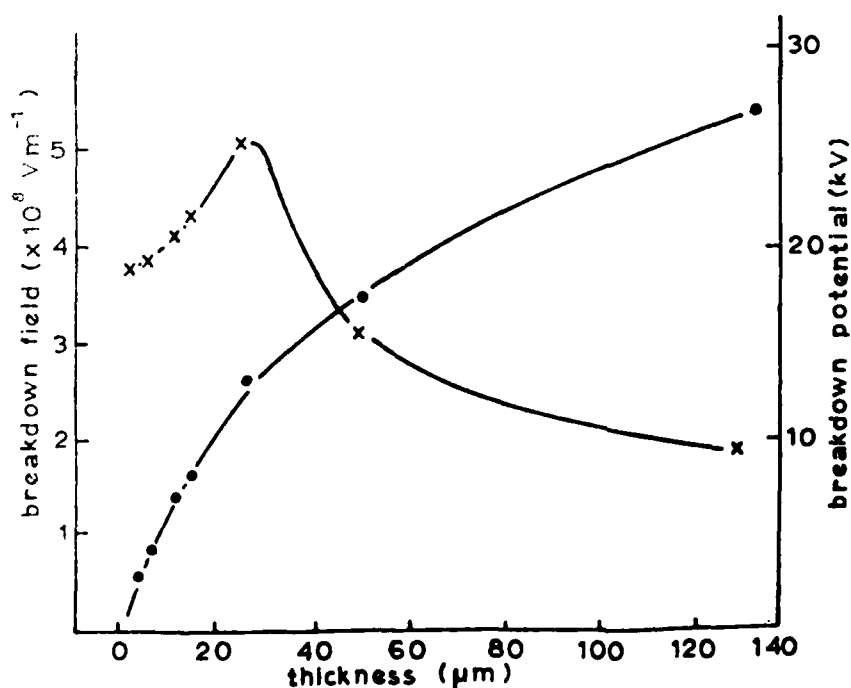

Fig. 3. The breakdown behaviour of PVF_2 film due to corona charging for 1 min at 20°C as a function of film thickness: \times , field; \bullet , potential.

the diffracted peak heights of the (100) and (020) planes of the non-polar form 2 structure at 2θ values of 17.9° and 18.6° respectively, (ii) by the increase in the (110) peak height of the intermediate polar form 2 at the 2θ value of 20.2° and finally (iii) by the appearance of a small shoulder (Fig. 3) due to the presence of the composite peak of (110)-(200) planes of the polar form 1 structure at the 2θ value of 20.8° . It is of interest to note that on corona poling at elevated temperatures the conversion of the non-polar form 2 structure into the polar form 1 structure is significantly enhanced as may be seen in Fig. 5. It has been suggested³¹ that an increased piezoelectric activity in PVF_2 may be achieved by corona poling at elevated temperatures. However, the results¹¹, shown in Fig. 6 for films $50\ \mu\text{m}$ thick, demonstrate that, although the threshold field for the initiation of the piezoelectric activity is reduced by raising the temperature of the sample for corona poling, the maximum achievable piezoelectric coefficient d_{31} is not increased. This may be

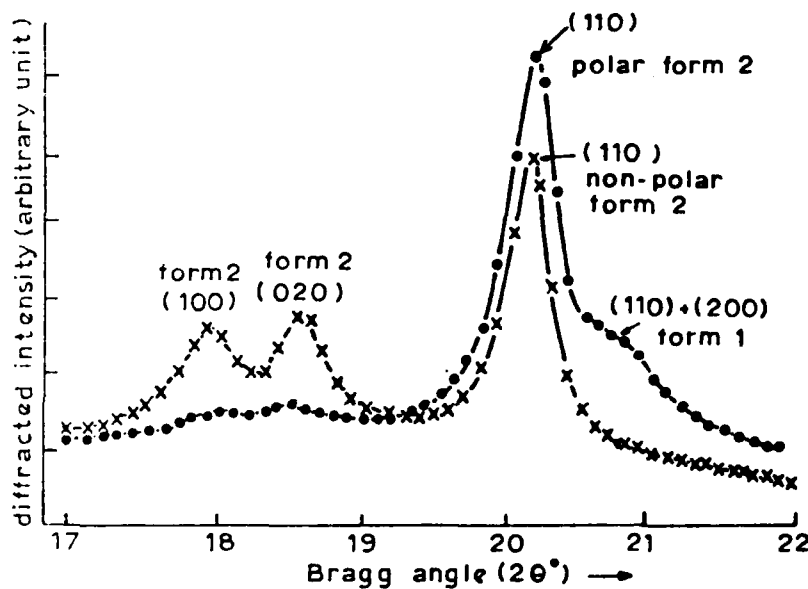

Fig. 4. The effect of breakdown field on the X-ray diffraction profile of a PVF_2 film $50\ \mu\text{m}$ thick: x, virgin sample; ●, after breakdown.

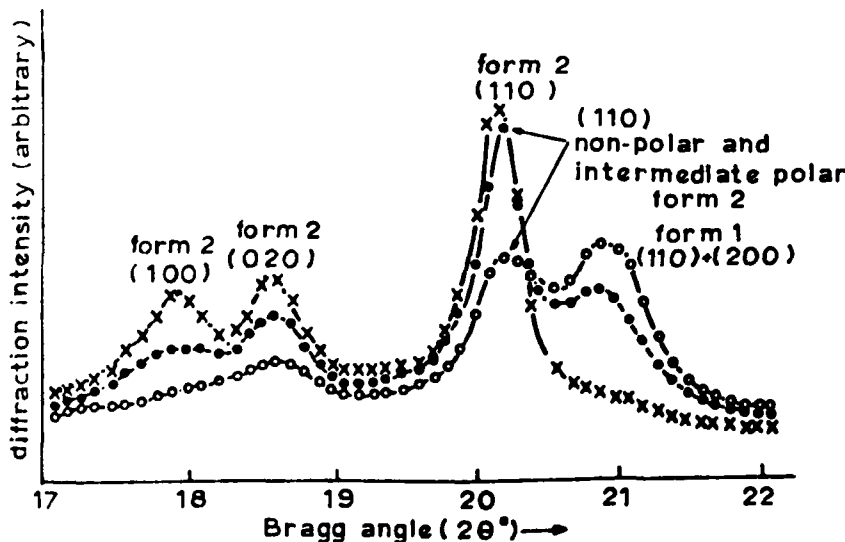

Fig. 5. Field-induced structure modification in a PVF_2 film $50\ \mu\text{m}$ thick: x, virgin sample; ●, after charging to 10 kV for 1 min at 100°C ; ○, after charging to 10 kV for 1 min at 150°C .

adequately explained by the fact that the dielectric breakdown strength is significantly reduced with increasing temperature. As a result the poling field needs to be considerably reduced at elevated temperatures. Although it is possible to pole PVF₂ of either form 1 or form 2 structure successfully by corona charging, there is still a need to overcome the problem of dielectric breakdown associated with thick films³².

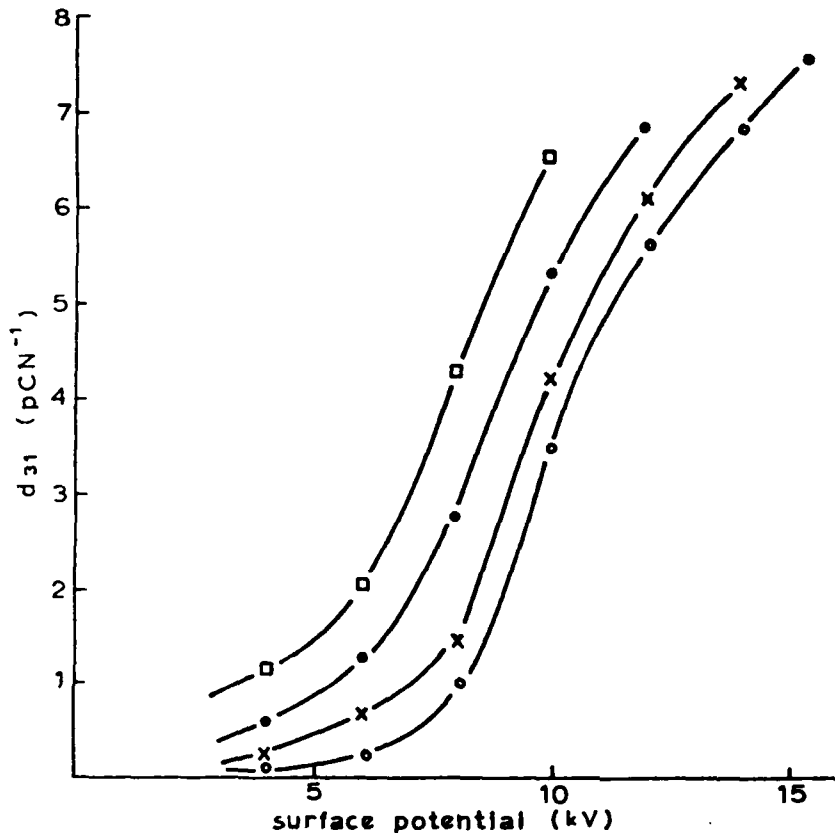

Fig. 6. The variation in the piezoelectric coefficient d_{31} with poling voltage at various temperatures for a PVF₂ film 50 μm thick (charging time, 1 min): ○, 20 °C; ×, 60 °C; ●, 100 °C; □, 140 °C.

For piezoelectric sensing elements, using the thickness mode effect, the most relevant piezoelectric coefficient is d_{33} which is associated with a uniaxial stress normal to the surfaces of the film. In practice, a measurement of d_{33} is difficult because the film must be completely free to move laterally while the stress is being applied and some workers³³ have been forced to work around the problem by measuring the inverse piezoelectric effect. Other workers¹⁶ have measured the hydrostatic coefficient d_h , which is related to d_{33} by the following expression:

$$d_h = d_{31} + d_{32} + d_{33} \quad (1)$$

However, even this technique is often erroneous because of a pyroelectric effect which is produced when a change in temperature accompanies a change in pressure. d_{31} has been found to be proportional to the hydrostatic coefficient d_h for unstretched and biaxially stretched films²⁰ and, for all films employed in the present work, was found to be equal to d_{32} . Thus, a single measurement of d_{31} completely characterizes the field-induced polarization of these samples.

There are two other factors, however, which might influence a decision on

material thickness and these are (i) the electrode capacitance and (ii) the frequency of the fundamental thickness mode resonance. An active element size of no greater than 1 cm diameter may be considered to be acceptable. From the dielectric constant *versus* frequency plot, shown in Fig. 7, it may be observed that the real part of the dielectric constant ϵ' of PVF₂, measured by the conventional bridge technique, approaches a value of 6 at 1 MHz which implies a total sample capacitance of 42×10^{-12} F for films 100 μm thick. When such an element is mounted appropriately in a transducer body and fitted with a coaxial connector and a length of coaxial cable about 1 m long, approximately half of the signal will be lost owing to the capacitance of the transmission line. This, however, may be overcome with the use of a unity gain high impedance field effect transistor buffer amplifier driving the guard of a triaxial cable but the bandwidth may have to be sacrificed. The fundamental thickness mode resonance for the sample 100 μm thick occurs at a frequency of about 11 MHz. However, if the sample is non-uniformly polarized, the thickness mode resonance frequency may be significantly reduced.

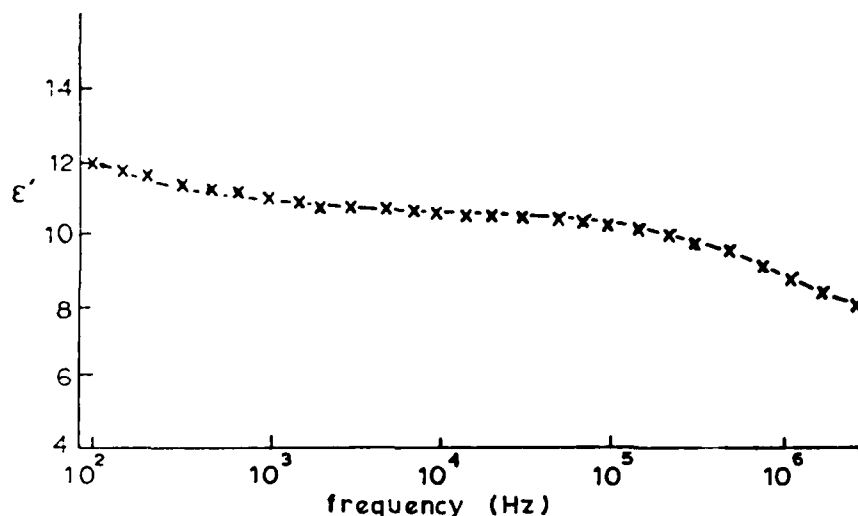

Fig. 7. Frequency variation of the dielectric constant of a PVF₂ film 50 μm thick measured at 20°C.

4. CONCLUSIONS

It has been shown that, by corona charging, films of PVF₂ can be rendered piezoelectric with high values of d_{31} irrespective of orientation and crystal structure. Conventional charging methods have demonstrated that the thinnest films may not be the most useful owing to the influence of the metallized electrodes.

The piezoelectric coefficients are limited by the dielectric breakdown strength, especially at elevated temperatures, which means that the thinner biaxially oriented materials have the highest coefficients.

Increasing the charging temperature of form 2 films modifies the crystal transformation process but does not increase the maximum achievable coefficient because of a decrease in the dielectric strength.

It is concluded that films 25 and 50 μm thick are best suited to wideband pressure transducer applications.

ACKNOWLEDGMENT

This work is financially supported by a U.S. Army research grant.

REFERENCES

- 1 R. Hasegawa, Y. Takahashi, Y. Chatani and H. Tadokoro, *Polym. J.*, **3** (1972) 591.
- 2 R. Hasegawa, Y. Takahashi, Y. Chatani and H. Tadokoro, *Polym. J.*, **3** (1972) 600.
- 3 J. B. Lando, H. G. Off and A. Peterlin, *J. Polym. Sci., Part A*, **4** (1966) 941.
- 4 J. B. Lando and W. W. Doll, *J. Macromol. Sci., Phys.*, **2** (1968) 205.
- 5 W. W. Doll and J. B. Lando, *J. Macromol. Sci., Phys.*, **2** (1968) 219.
- 6 W. W. Doll and J. B. Lando, *J. Macromol. Sci., Phys.*, **4** (1970) 309.
- 7 Ye. L. Gal'perin, Yn. V. Strogalin and M. P. Mlenik, *Vysokomol. Soedin.*, **7** (1965) 933.
- 8 Ye. L. Gal'perin and B. P. Kosmynin, *Vysokomol. Soedin., Ser. A*, **11** (1969) 1432.
- 9 D. K. Das-Gupta and K. Doughty, *J. Phys. D*, **13** (1980) 95.
- 10 H. Ohigashi, *J. Appl. Phys.*, **47** (1976) 949.
- 11 R. J. Shuford, A. F. Wilde, J. J. Ricca and G. R. Thomas, *Polym. Eng. Sci.*, **16** (1976) 25.
- 12 G. Cessac and J. G. Curso, *J. Polym. Sci., Polym. Phys. Edn.*, **12** (1974) 695.
- 13 M. Oshiki and E. Fukada, *Jpn. J. Appl. Phys.*, **15** (1976) 43.
- 14 M. Latour, *J. Electrostat.*, **2** (1977) 241.
- 15 D. K. Das-Gupta and K. Doughty, *J. Appl. Phys.*, **49** (8) (1978) 4601.
- 16 M. G. Broadhurst, G. T. Davis, J. E. McKinney and R. E. Collins, *J. Appl. Phys.*, **49** (10) (1978) 4992.
- 17 D. K. Das-Gupta, K. Doughty and D. B. Shier, *J. Electrostat.*, **7** (1979) 267.
- 18 M. R. Broadhurst and G. T. Davis, in G. M. Sessler (ed.), *Electrets*, Springer, Berlin, 1980, p. 285.
- 19 R. G. Kepler and R. A. Anderson, *Crit. Rev. Solid State Mater. Sci.*, **9** (4) (1980) 399.
- 20 K. Doughty, *Ph.D. Thesis*, University of Wales, 1979.
- 21 L. N. Bui, H. J. Shaw and T. Zitelli, *IEEE Trans. Sonics Ultrason.*, **24** (1977) 331.
- 22 D. Dameron and J. G. Linvill, Stanford University, unpublished, 1978.
- 23 D. K. Das-Gupta, K. Doughty, R. J. Shuford and Y. Hinton, *Annu. Rep., Conf. Electr. Insul. Dielectr. Phenom.*, (1982) 268.
- 24 R. V. Williams, *Acoustic Emission*, Hilger, Bristol, 1980.
- 25 S. P. Ying, *Crit. Rev. Solid State Sci.*, **4** (1973) 475.
- 26 N. Yoshimura, H. Judo and F. Noto, *Jpn. J. Appl. Phys.*, **20** (11) (1981) L775.
- 27 D. K. Das-Gupta and K. Doughty, *J. Phys. D*, **11** (1978) 2415.
- 28 G. T. Davis, J. E. McKinney, M. G. Broadhurst and S. C. Roth, *J. Appl. Phys.*, **49** (1978) 4998.
- 29 K. Doughty and P. Pantelis, *J. Mater. Sci.*, **15** (1980) 974.
- 30 N. Takahashi and A. Odajima, unpublished work, 1979.
- 31 S. S. Bamji and M. M. Perlman, *J. Polym. Sci., Polym. Phys. Edn.*, **19** (1981) 1365.
- 32 F. M. Clark, *Insulating Materials for Design and Engineering Practice*, Wiley, New York, 1962.
- 33 R. G. Kepler and R. A. Anderson, *J. Appl. Phys.*, **49** (8) (1978) 4490.

END

FILMED

4-85

DTIC