

AD-A151 746

RADIOMETER INTEGRATED INTO A COMMUNICATION TERMINAL(U)
AEROSPACE CORP EL SEGUNDO CA ELECTRONICS RESEARCH LAB
R B DYBDAL 05 FEB 85 TR-0084A(5417-01)-1 SD-TR-85-05
F04701-83-C-0084

1/1

UNCLASSIFIED

F/G 1772

NL

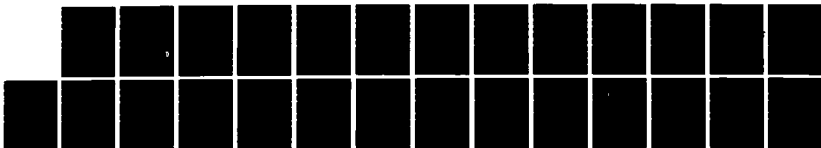

END
FILMED
DTIC

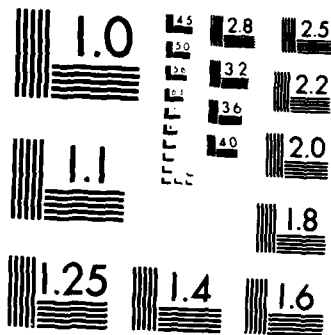

MICROCOPY RESOLUTION TEST CHART
NATIONAL BUREAU OF STANDARDS-1963-A

Radiometer Integrated into a Communication Terminal

AD-A151 746

R. B. DYBDAL
✓ Electronics Research Laboratory
Laboratory Operations
The Aerospace Corporation
El Segundo, Calif. 90245

5 February 1985

DTIC FILE COPY

APPROVED FOR PUBLIC RELEASE;
DISTRIBUTION UNLIMITED

DTIC
SELECTED
MAR 27 1985
E D

Prepared for
SPACE DIVISION
AIR FORCE SYSTEMS COMMAND
Los Angeles Air Force Station
P.O. Box 92960, Worldway Postal Center
Los Angeles, Calif. 90009-2960

85 03 11 082

This report was submitted by The Aerospace Corporation, El Segundo, CA 90245, under Contract No. FO4701-83-C-0084 with the Space Division, P.O. Box 92960, Worldway Postal Center, Los Angeles, CA 90009-2960. It was reviewed and approved for The Aerospace Corporation by D. H. Phillips, Director, Electronics Research Laboratory. Lt. Harold J. Morgan, SD/CGX, was the Air Force project officer.

This report has been reviewed by the Public Affairs Office (PAS) and is releasable to the National Technical Information Service (NTIS). At NTIS, it will be available to the general public, including foreign nationals.

This technical report has been reviewed and is approved for publication. Publication of this report does not constitute Air Force approval of the report's findings or conclusions. It is published only for the exchange and stimulation of ideas.

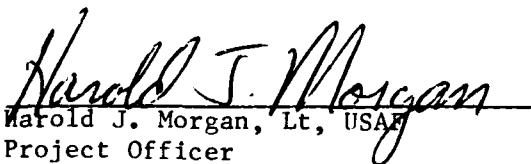
Harold J. Morgan, Lt, USAF
Project Officer

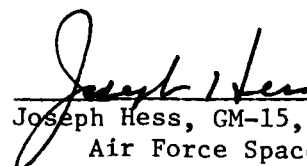
Joseph Hess, GM-15, Director, West Coast Office
Air Force Space Technology Center

UNCLASSIFIED

SECURITY CLASSIFICATION OF THIS PAGE (When Data Entered)

REPORT DOCUMENTATION PAGE		READ INSTRUCTIONS BEFORE COMPLETING FORM
1. REPORT NUMBER SD-TR-85-05	2. GOVT ACCESSION NO. AD-A151746	3. RECIPIENT'S CATALOG NUMBER
4. TITLE (and Subtitle) RADIOMETER INTEGRATED INTO A COMMUNICATION TERMINAL		5. TYPE OF REPORT & PERIOD COVERED
		6. PERFORMING ORG. REPORT NUMBER TR-0084A(5417-01)-1
7. AUTHOR(s) Robert B. Dybdal		8. CONTRACT OR GRANT NUMBER(s) FO4701-83-C-0084
9. PERFORMING ORGANIZATION NAME AND ADDRESS The Aerospace Corporation El Segundo, Calif. 90245		10. PROGRAM ELEMENT, PROJECT, TASK AREA & WORK UNIT NUMBERS
11. CONTROLLING OFFICE NAME AND ADDRESS Space Division Los Angeles Air Force Station Los Angeles, Calif. 90009-2960		12. REPORT DATE 5 February 1985
		13. NUMBER OF PAGES 22
14. MONITORING AGENCY NAME & ADDRESS (if different from Controlling Office)		15. SECURITY CLASS. (of this report) Unclassified
		15a. DECLASSIFICATION/DOWNGRADING SCHEDULE
16. DISTRIBUTION STATEMENT (of this Report) Approved for public release; distribution unlimited.		
17. DISTRIBUTION STATEMENT (of the abstract entered in Block 20, if different from Report)		
18. SUPPLEMENTARY NOTES		
19. KEY WORDS (Continue on reverse side if necessary and identify by block number) Communication Terminal, Propagation Propagation Loss Radiometer		
20. ABSTRACT (Continue on reverse side if necessary and identify by block number) Passive radiometric techniques for the measurement of weather-induced propagation loss in real time are well established. As communications systems move into the EHF bands, such a real-time indication of link loss would provide terminal operators with availability information, and in addition, a complementary diagnostics capability for terminal performance. A low-cost technique and its design issues to integrate a radiometer into a communications terminal are discussed. The radiometer is designed to work simultaneously with a frequency-hopped communication receiver and provides		

UNCLASSIFIED

SECURITY CLASSIFICATION OF THIS PAGE(When Data Entered)

19. KEY WORDS (Continued)

20. ABSTRACT (Continued)

a real-time measurement of propagation loss, detection and angular location of interference, transmitter power control to reduce excess margin and detectability, and diagnostics which complement typical BITE capability. The cost of the additional hardware for the radiometric capability is low, because the high cost elements are those shared and already an inherent part of the communication terminal. The addition of such a radiometric capability to SHF/EHF terminals should be considered in future designs.

up. v. n. h. p. n. n.

Reynolds

extremely high frequency

UNCLASSIFIED

SECURITY CLASSIFICATION OF THIS PAGE(When Data Entered)

CONTENTS

I. INTRODUCTION..... 5

II. RADIOMETRIC SYSTEM OPERATION..... 7

III. CANDIDATE DESIGN IMPLEMENTATION..... 13

 A. Design Concept..... 13

 B. Projected Characteristics and Design Considerations..... 14

 C. Filter Separation Requirements..... 18

 D. Radiometric Response..... 20

 E. Projected Costs..... 21

IV. SUMMARY AND CONCLUSIONS..... 23

Accession For	
NTIS GRA&I	<input checked="" type="checkbox"/>
DTIC TAB	<input type="checkbox"/>
Unannounced	<input type="checkbox"/>
Justification	
By	
Distribution/	
Availability Codes	
Dist	Avail and/or Special
A-1	



FIGURES

1. Radiometric System Operation.....	7
2. Emission Temperature vs. Attenuation.....	8
3. Radiometer Electronics.....	10
4. Increase in System Noise Figure and Emission Temperature as a Function of Increased Attenuation Relative to a 5 dB Margin.....	12
5. Block Diagram of Radiometer Integration into Frequency-Hopped Terminal.....	14
6. Relationship Between Communication and Radiometer Bandwidths.....	15
7. Spectral Characteristics at Each Hopped Frequency.....	18
8. Equivalent Temperature of the Signal Power in the Radiometer Passband vs. Filter Separation.....	19
9. Display Concept.....	21

I. INTRODUCTION

As the operation of communications terminals extends into the extremely high frequency (EHF) band, increased sensitivity to weather conditions leads to greater concern for system availability, and a radiometer is a well-established technique to measure weather-induced propagation loss in real time. For tactical terminals, a low-cost indication of the potential link availability and outage can provide a useful aid for system operation. The purpose of this report is to describe a radiometric subsystem that is integrated into a communications terminal so as to capitalize on the existing investment of high cost elements, such as the antenna and radio frequency/intermediate frequency (RF/IF) front end subsystems; thus, a cost-effective implementation results.

While a major concern for EHF system operations stems from outages induced by propagation loss, other applications for the real-time output of the radiometer naturally evolve. All aircraft, naval, and some ground terminal installations incorporate a radome whose transmission efficiency is extremely sensitive to not only wetting by precipitation, but also condensation and salt spray and deposits; changes in radome transmission efficiency can be directly measured by a radiometer. In tactical applications, attenuation can occur if the terminal has to operate under a foliage cover; the radiometer can measure such attenuation. System link budgets typically include an allocation for propagation loss so that the system will operate to a projected availability level. In clear conditions, the excess margin conflicts with the objectives of systems which have low probability of intercept (LPI) requirements or susceptibility to physical attacks directed by radiation-homing sensors. For such systems, the effective radiated power (ERP) of the terminal can be controlled in proportion to the real-time propagation loss measured by the radiometer to minimize detectability. Similarly, power control can also be used in frequency-division multiple access (FDMA) systems for leveling. The radiometer can also measure intentional or unintentional interference on the downlink independent of other techniques, and if

used in a direction-finding mode, can identify the direction of arrival of the interference. Finally, the radiometer provides a limited diagnostics capability, which can independently augment the normal built-in test equipment (BITE) functions. The potential applications for the integrated radiometer therefore extend well beyond just measuring the propagation loss.

The design and performance requirements for the radiometer will be reviewed. A technique that integrates the radiometer into a communications terminal, which uses a frequency-hopped spread spectrum modulation, will be developed. Finally, a rough estimate of the production costs for the additional hardware required to add the radiometric capability is presented.

II. RADIOMETRIC SYSTEM OPERATION

This section will review the operation of a radiometer and establish the requirements for this application. The basis for the measurement of attenuation stems from the thermal noise radiation associated with the loss as described by Fig. 1. The spectral density of the thermal noise contributed by the path and measured at the terminals of the radiometric antenna is given by kT_E , where k is Boltzmann's constant, and T_E is the emission temperature. This spectral density expression is the Rayleigh-Jeans approximation of Planck's law and is valid at millimeter-wave frequencies, e.g., the error of this approximation at 100 GHz for $T_E = 300$ K is 0.8%.

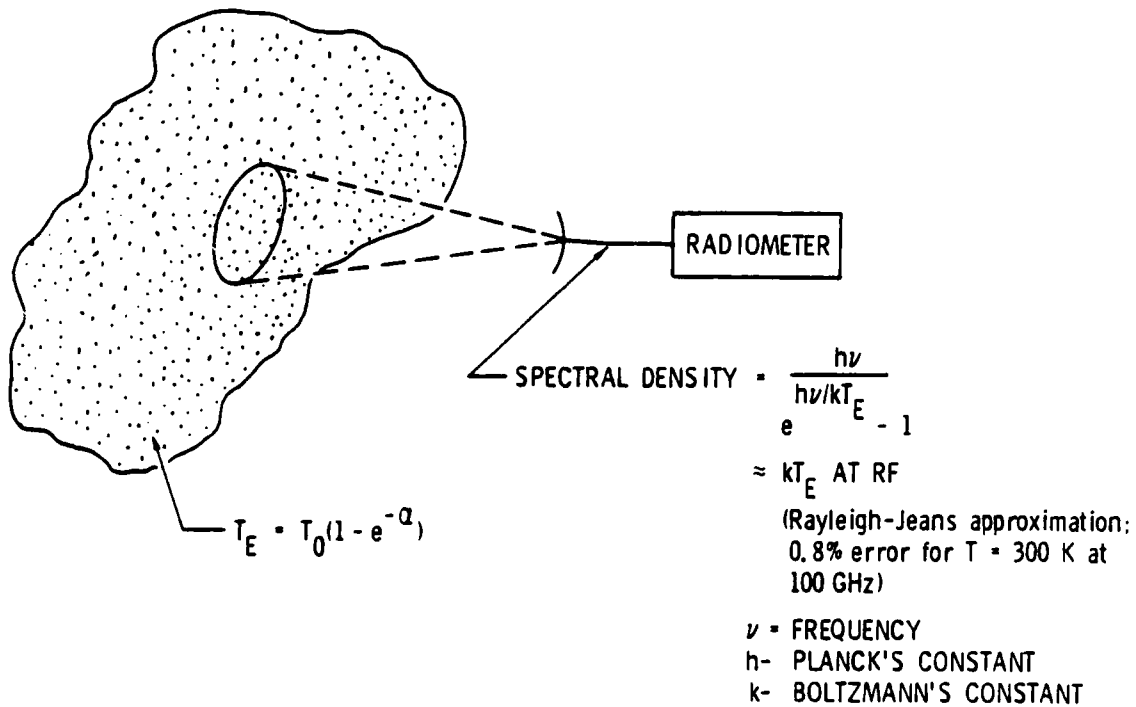

Fig. 1. Radiometric System Operation

The emission temperature, T_E , is related to the path loss, $L(\text{ind B})$, by

$$T_E = T_0(1 - 10^{-L/10}) \quad (1)$$

where T_0 is an empirically derived constant. It should be noted that the same physics and analysis are used to calculate noise temperature contributions of waveguide loss.

The relationship between the emission temperature and the attenuation is plotted in Fig. 2. Three values of T_0 are presented in this curve. The value $T_0 = 290 \text{ K}$ is appropriate for loss at an ambient temperature, e.g., condensation or water on the radome. The value $T_0 = 270 \text{ K}$ is a nominal number for rain loss and is somewhat lower than ambient because the physical temperature of raindrops reduces with increasing altitude; $T_0 = 270 \text{ K}$ therefore represents

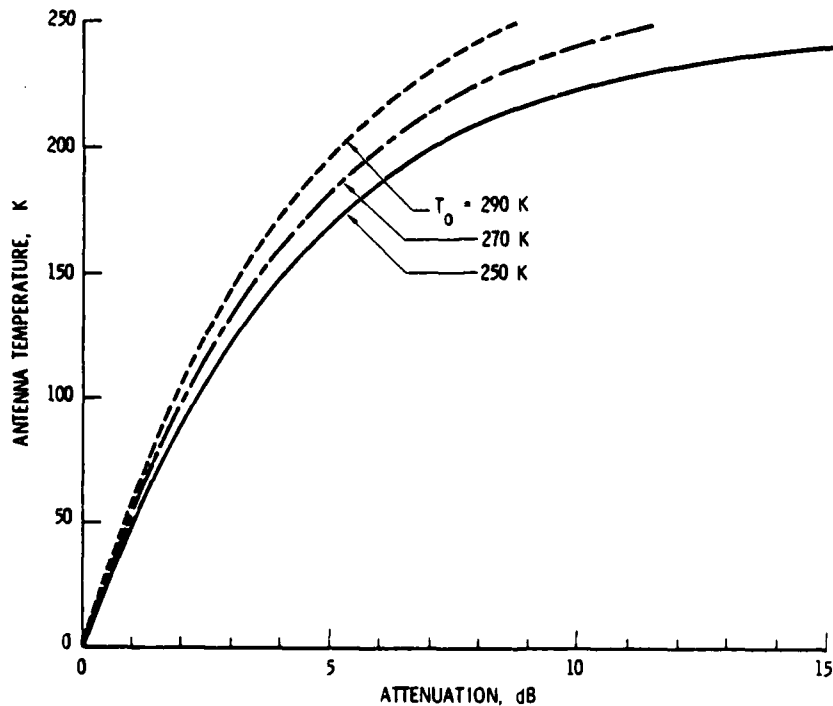

Fig. 2. Emission Temperature vs. Attenuation

an average value between ground level and the altitude at which raindrops turn into ice particles, which have relatively little loss. The value $T_0 = 250$ K is appropriate for higher rain rates at higher millimeter-wave frequencies; in this case, energy is scattered from the beam reducing the value of T_0 .

Several points should be made regarding the values in Fig. 2:

1. The dynamic range of the attenuation measurement is limited by the uncertainty in the value of T_0 , which can be refined when specific mechanisms and frequencies are considered.
2. Typically, the radiometer would operate on a lower downlink frequency and project the loss for the higher uplink frequency. In this case, only a limited dynamic range is required to measure the weather loss margin appropriate for a tactical terminal.
3. A measurement of changes in attenuation to the order of 1 dB does not require great resolution of the emission temperature relative to state-of-the-art radiometric performance. Thus, the opportunity for a cost-effective implementation is enhanced.

The electronics for the radiometric receiver are relatively simple and would be implemented, as indicated in Fig. 3. The thermal noise at RF, T_E , is downconverted and amplified, square-law detected, and integrated. The output of the radiometer is a DC voltage whose level is linearly related to the difference between the emission temperature, T_E , and a known reference temperature, T_{REF} , by a scale factor of β . The attenuation can be related to the emission temperature through Eq. (1). The accuracy of the radiometer is typically specified in terms of ΔT , which is the standard deviation of the measured temperature value. The value of ΔT can be obtained from

$$\Delta T = \frac{K(T_E + T_{REC})}{\sqrt{B\tau}} \quad (2)$$

where

K varies from 1 to 2 depending on hardware implementation

T_E = emission temperature to be measured

T_{REC} = noise temperature of receiver exclusive of T_E

B = IF bandwidth

τ = integration time

The sensitivity of a radiometer, ΔT , is often specified for a 1 sec integration time. The present state-of-the-art for millimeter-wave radiometers used in remote sensing applications is a ΔT of a few hundredths degrees Kelvin. Such sensitivity far exceeds the resolution needed to measure attenuation shown in Fig. 2 to a 1 dB accuracy.

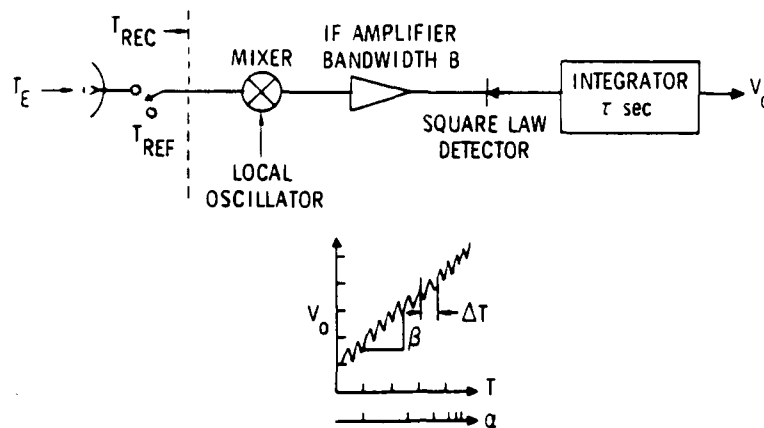

Fig. 3. Radiometer Electronics

In operation, a system of this type has a small, but finite, probability that the antenna beam will intercept the sun. In this case, the radiometer output will greatly increase. A typical radiometric temperature for the sun is 10,000 K, and it subtends an angle of 0.5 deg. For tactical systems, the beamwidth of the antenna is somewhat broader than 0.5 deg, so that the peak temperature indicated by the radiometer would be less than 10,000 K even if the antenna were boresighted with the sun. When the system is operated with the antenna pointed towards the sun, the communications system is also degraded because the total system noise temperature increases with the contribution from the sun. However, the necessary alignment between the terminal, satellite, and sun has a low probability which could be determined a priori, and the alignment would persist for a relatively short period.

LABORATORY OPERATIONS

The Laboratory Operations of The Aerospace Corporation is conducting experimental and theoretical investigations necessary for the evaluation and application of scientific advances to new military space systems. Versatility and flexibility have been developed to a high degree by the laboratory personnel in dealing with the many problems encountered in the nation's rapidly developing space systems. Expertise in the latest scientific developments is vital to the accomplishment of tasks related to these problems. The laboratories that contribute to this research are:

Aerophysics Laboratory: Launch vehicle and reentry fluid mechanics, heat transfer and flight dynamics; chemical and electric propulsion, propellant chemistry, environmental hazards, trace detection; spacecraft structural mechanics, contamination, thermal and structural control; high temperature thermomechanics, gas kinetics and radiation; cw and pulsed laser development including chemical kinetics, spectroscopy, optical resonators, beam control, atmospheric propagation, laser effects and countermeasures.

Chemistry and Physics Laboratory: Atmospheric chemical reactions, atmospheric optics, light scattering, state-specific chemical reactions and radiation transport in rocket plumes, applied laser spectroscopy, laser chemistry, laser optoelectronics, solar cell physics, battery electrochemistry, space vacuum and radiation effects on materials, lubrication and surface phenomena, thermionic emission, photosensitive materials and detectors, atomic frequency standards, and environmental chemistry.

Electronics Research Laboratory: Microelectronics, GaAs low noise and power devices, semiconductor lasers, electromagnetic and optical propagation phenomena, quantum electronics, laser communications, lidar, and electro-optics; communication sciences, applied electronics, semiconductor crystal and device physics, radiometric imaging; millimeter wave, microwave technology, and RF systems research.

Information Sciences Research Office: Program verification, program translation, performance-sensitive system design, distributed architectures for spaceborne computers, fault-tolerant computer systems, artificial intelligence and microelectronics applications.

Materials Sciences Laboratory: Development of new materials: metal matrix composites, polymers, and new forms of carbon; nondestructive evaluation, component failure analysis and reliability; fracture mechanics and stress corrosion; analysis and evaluation of materials at cryogenic and elevated temperatures as well as in space and enemy-induced environments.

Space Sciences Laboratory: Magnetospheric, auroral and cosmic ray physics, wave-particle interactions, magnetospheric plasma waves; atmospheric and ionospheric physics, density and composition of the upper atmosphere, remote sensing using atmospheric radiation; solar physics, infrared astronomy, infrared signature analysis; effects of solar activity, magnetic storms and nuclear explosions on the earth's atmosphere, ionosphere and magnetosphere; effects of electromagnetic and particulate radiations on space systems; space instrumentation.

IV. SUMMARY AND CONCLUSIONS

The objective of this effort was to develop a cost-effective technique to integrate a radiometer into a communications terminal. Applications for the real-time radiometric output include a determination of the propagation loss, radome transmission efficiency, transmitter power control for systems with LPI requirements or a susceptibility to physical attack directed by radiation-homing sensors or for leveling in FDMA systems, detection and angular location of interference, and a diagnostics capability which complements typical BITE functions.

A technique was proposed that implements the radiometer at an IF level and allows the high cost antenna and RF/IF subsystems to be simultaneously used by the radiometer and the communications receiver. The output from the radiometer could be displayed in a simple analog format, which would be effective for the terminal operator. The projected production cost for the additional radiometric capability would be a small fraction of the total terminal cost.

subjective, the conclusion that the relative cost of the radiometric capability compared with the total terminal cost is a very small fraction remains true. Thus, a major goal, a cost-effective integration of a radiometer into a communications terminal, has been achieved.

<u>Components</u>	<u>Costs</u>
Calibration	200
Power Divider	200
IF Amplifier and Filter	1500
Detector	200
Integrator	100
Display	<u>1000</u>
Total	\$3200

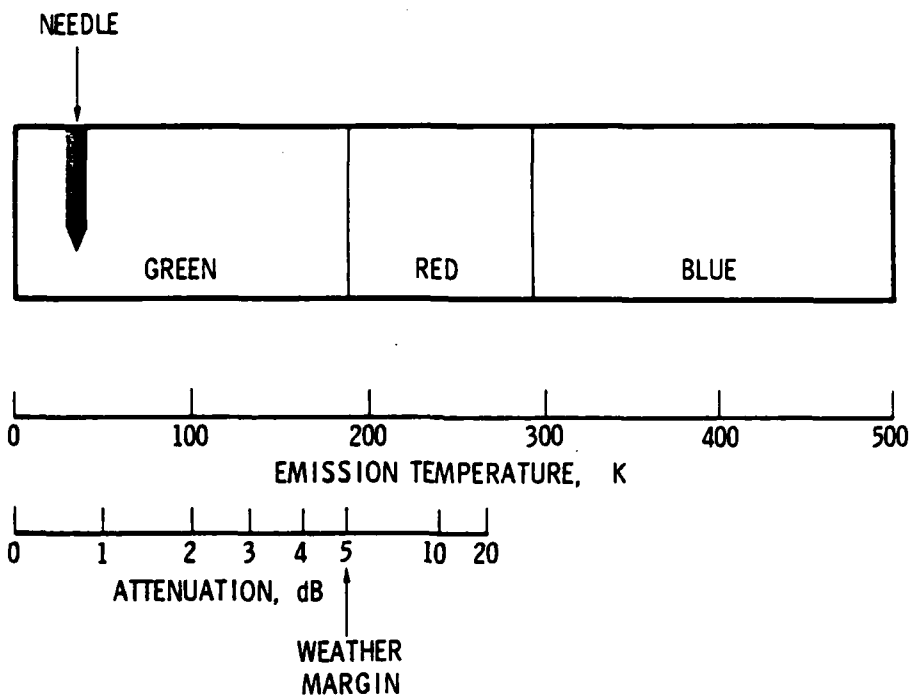

Fig. 9. Display Concept

E. PROJECTED COSTS

An important issue is the hardware cost required for the additional radiometric capability. The proposed implementation capitalizes on the existing investment of high cost components, which are an inherent part of every communications terminal. The additional parts needed by the radiometer are at the IF and DC levels and, thus, are relatively inexpensive. A rough estimate of these costs based on commercial components is presented in the listing below, and the individual elements are indicated by the portion of the terminal enclosed by the dotted lines in Fig. 5. Whereas such cost estimates are

D. RADIOMETRIC RESPONSE

The response of the radiometer to different conditions will be discussed in this section. These considerations also lead to a simple display concept, which could be used effectively by terminal personnel. A key factor to keep in mind is that the DC output level of the radiometer is linearly related to the emission temperature.

The radiometer normally indicates a DC voltage corresponding to the sky temperature, which under clear conditions and typical elevation angles may be 20 to 40 K. As the loss increases, the emission temperature rises in accordance with Fig. 2, and the DC voltage increases. At some point, the margin assigned to weather loss is exceeded. As the loss continues to increase, the emission temperature will approach 290 K, and a second threshold can be assigned. If this second threshold is exceeded, the presence of interference is indicated.

This situation suggests a simple analog voltmeter display which could be effectively used by personnel who operate the terminal. A green range indicating potential link availability could be used when the radiometric voltage is less than the first threshold. A red range, indicating the weather margin has been exceeded, could be used when the radiometric output lies between the two thresholds. A blue range indicating interference could be used when the second threshold is exceeded. The display concept is represented in Fig. 9.

A radiometer might be particularly useful for systems which have LPI objectives or susceptibility to physical attack directed by radiation-homing sensors. The DC output of the radiometer could be used in a closed-loop fashion to vary the terminal's transmitter output in accordance with the propagation loss. When the first threshold is exceeded, the radiometer could terminate transmission. When the second threshold is exceeded, transmission from the terminal might not be desirable, because the presence of interference might also indicate a threat to the terminal. In this case, the radiometer could be used to more extensively explore the nature and location of the interference prior to resuming transmission.

The signal power can be converted into an equivalent temperature, which is the most useful form for this application. For this analysis, the signal power over a 1 MHz bandwidth for the radiometer was computed by the integration of the $[(\sin X)/X]^2$ representation of the signal structure. The equivalent temperature of the signal, T_{eq} , can be related to the received signal power, P_{rec} , by

$$P_{rec} = k T_{eq} B \quad (3)$$

where B is the 1 MHz bandwidth of the radiometer. The results of this computation are presented in Fig. 8 as a function of the frequency separation of the two filters. For the values assumed, a frequency separation of 5 MHz or greater would result in less than a 10 K bias offset in the radiometric output and represents only a small error relative to the emission temperature of the propagation loss. A filter frequency separation of 10 MHz would result in a smaller 2.5 K offset. These values are a worst case level for a signal constantly present; when the system provides multiple access, the temperatures are reduced by the duty cycle of the total signal dwell time relative to the radiometric integration time,

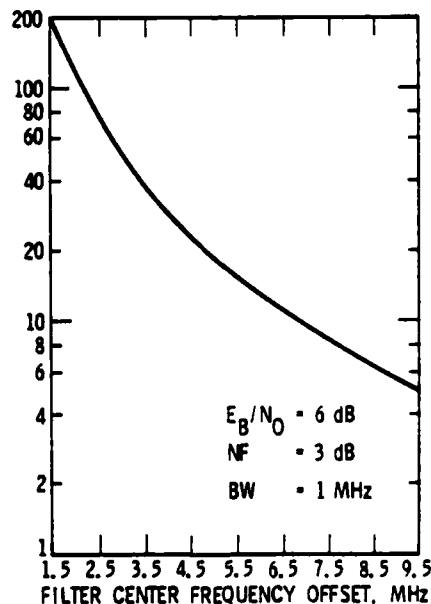

Fig. 8. Equivalent Temperature of the Signal Power in the Radiometer Passband vs. Filter Separation

C. FILTER SEPARATION REQUIREMENTS

Another design issue which remains is the selection of the filter frequency separation between the communication and the radiometric channels. The problem results because signal power in the skirts of the signal spectrum contributes to the radiometric output; thus, the two bandwidths must be separated sufficiently so that the signal power represents only a small temperature bias error. The following assumptions were used in this analysis:

1. The signal is frequency shift keyed at a 1 Mbps rate, and its power spectrum can be modeled as a $[(\sin X)/X]^2$ function.
2. The signal has a 6 dB E_b/N_0 level.
3. The radiometric system parameters are identical with those previously used.

Based on these assumptions the signal spectrum at each hop frequency presented in Fig. 7 was derived. For reference purposes, the spectral density of the receiver noise and emission temperatures of 30 and 290 K, the normal extremes for propagation loss, are also shown.

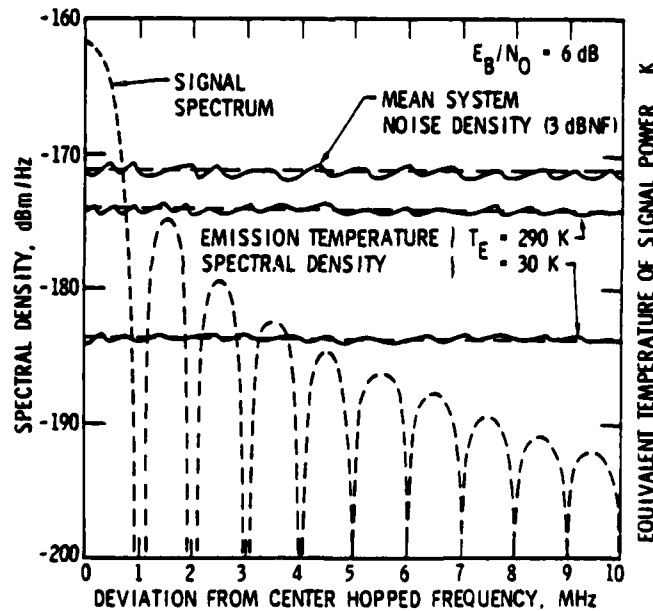

Fig. 7. Spectral Characteristics at Each Hopped Frequency

For applications in which the radiometer is used to measure the arrival angle of interference in a direction-finding mode, dynamic range considerations also affect the selection of the IF gain level. Whereas interference may result in a small increase in the power level when the antenna is pointed towards the satellite, pointing the antenna towards the interference increases the interference power by the ratio of the main beam gain to the antenna gain in its sidelobe region; this ratio is large for millimeter wave antennas. In a direction-finding mode, the receiver should not saturate, so that either automatic gain control (AGC) techniques or switching out some of the IF gain must be used to preserve system linearity. It should be noted that other techniques for interference detection, such as bit error rate measurements, have an extremely limited dynamic range for such an application. When the interference signal structure is unknown, a radiometric receiver provides optimum detection. When detecting interference, the synthesizer could be reprogrammed to linearly sweep over the operating bandwidth. The 1 MHz resolution of the radiometer provides good definition of the spectral structure of the interference.

Finally, provision to switch the radiometer from its normal filter to the one that contains the communication signal can provide a diagnostic capability for the receiver dehopping, which is independent of the BITE functions typically provided. Under normal operation, the channel with the communication signal will provide a higher output than the radiometric channel because signal and noise components are present. If no difference in signal power is observed, frequency and/or timing errors in the dehopping process are indicated. This usage illustrates the capability of the radiometer to independently augment the normal BITE functions. In its BITE capacity, the radiometer provides information regarding:

1. Link propagation losses
2. Radome degradation
3. Receiver operation through dehopping

Thus, the radiometer can complement the normal BITE functions.

Gain fluctuations are increasingly important for applications which require long integration times to achieve the desired sensitivity; the modest sensitivity requirements of this application have relatively short integration times. Moreover, the gain fluctuation is aggravated by the relatively high gain values typically used in a radiometer. High amplifier gain is required ahead of the detector, so that the $1/f$ noise contributions from the detector and integrator do not degrade the overall system noise temperature. Typically, the square law detector is operated at a -30 dBm input level. For a 3 dB noise figure and a 1 MHz bandwidth, an insertion gain of 81 dB is required between the antenna feed and the square law detector.

In this application, the gain fluctuations play a minor role because high sensitivity is not required. As shown in Fig. 5, a temperature reference is provided at the IF level. The design of frequency-hopped receivers generally employs only enough gain in the receiver up to the frequency de hopping by the synthesizer to establish the system noise figure; the gain in these stages is purposely limited so that strong interference cannot saturate the system at that point and cause suppression of the desired signal. The bulk of the insertion gain for the radiometer occurs beyond the filter at the IF level. In this case, the gain fluctuation at the IF level is principally responsible for the ΔT degradation, and the use of the reference temperature can adequately monitor those changes. Given the low sensitivity requirements, the reference temperature needs to be monitored infrequently to correct for gain changes; e.g., every 10 to 100 sec. This correction would be automated so that no burden would exist for the user. The operation of this system is therefore substantially that of a total power system.

Some variation in the radiometric response will result as the system hops over its operating bandwidth, which is typically 1 GHz wide. The variations in radiometric response result because the noise figure and insertion gain of the receiver front end are not altogether independent of frequency. In operation, high hopping rates would be used, and the integrated radiometric response would consist of samples collected over the entire bandwidth. In this manner, the radiometer would respond to the average noise and insertion gain characteristics of the receiver front end.

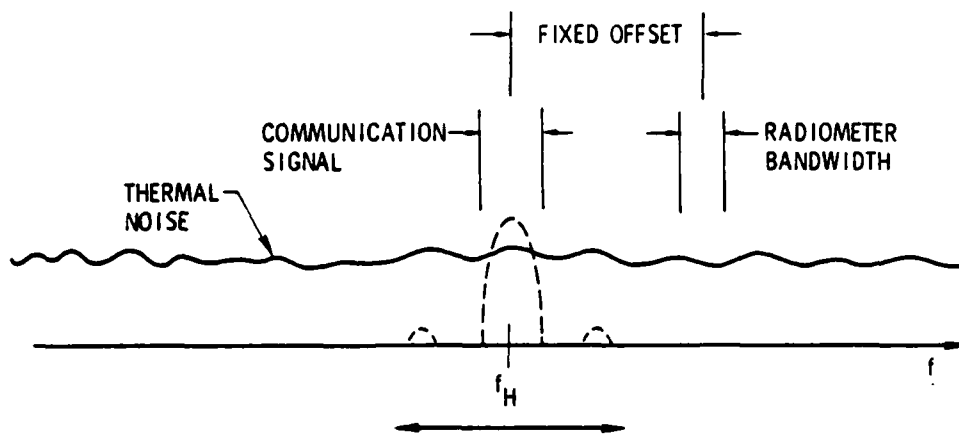

Fig. 6. Relationship Between Communication and Radiometer Bandwidths

channel will be taken as 1 MHz. An integration time of 1 sec and total power operation are also assumed. The total power operation, as discussed later, corresponds to a K value of 1 in Eq. (2). Under these assumptions a ΔT value of 0.6 K is projected, which is more resolution than required for this application.

A total power mode of operation for the radiometer basically means the radiometer continuously measures the noise during the integration time. The limitation of this mode of operation is the stability of the insertion gain of the system; i.e., changes in the gain value can be mistaken for changes in the emission temperature. The alternative is to switch to a stable reference temperature and examine the output voltage relative to that for the stable reference temperature. In practice, a matched load can provide such a reference. If the switching time is short relative to the gain fluctuation rate, any change in the insertion gain of the radiometer would be compensated. This process is referred to as Dicke switching and is commonly used in systems requiring extremely high resolution of emission temperature and long integration times. Because a Dicke-switched radiometer looks at the reference temperature as much as it looks at the antenna input, $K = 2$, in Eq. (2), and the ΔT is degraded by a factor of 2 relative to a total power radiometer.

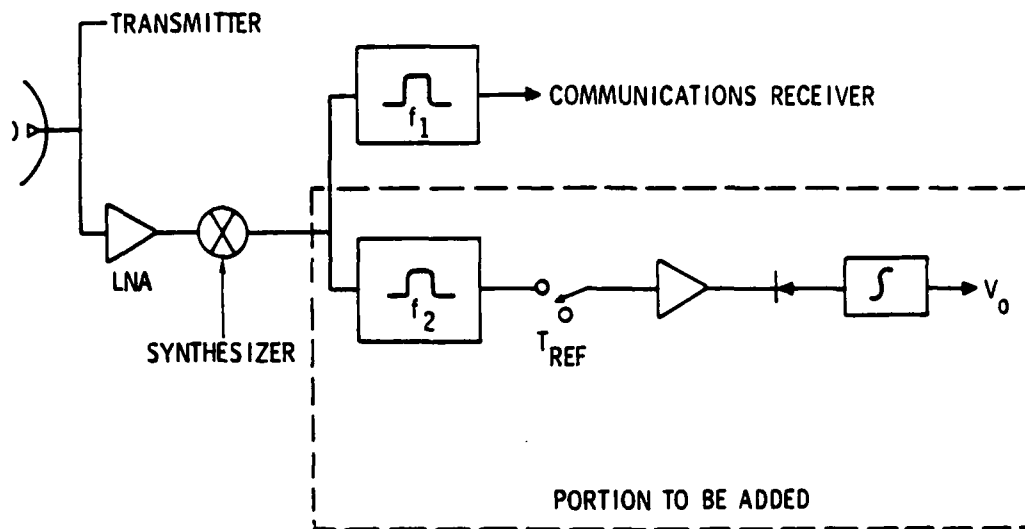

Fig. 5. Block Diagram of Radiometer Integration into Frequency-Hopped Terminal

If a hybrid power splitter is used at this point, outputs for the communications receiver and the radiometer are obtained. A filter, which is offset in frequency from the communication signal, would provide the radiometric receiver with basically a thermal noise output. A second filter would provide the normal output for the communications receiver. This technique would use the synthesizer to carry the communication signal and radiometer signal over the operating bandwidth and maintain a fixed offset between the communication signal and the segment used by the radiometer (Fig. 6). This achieves the basic goal of separating the communication and radiometric signal components.

B. PROJECTED CHARACTERISTICS AND DESIGN CONSIDERATIONS

The performance of the radiometer and some of its design considerations will be discussed in this section. The radiometric operation previously discussed is unique because it operates at IF frequencies rather than at RF frequencies as normally configured. The ΔT for the radiometer can be projected using Eq. (2). The receiver, as referenced to the antenna input, is assumed to have a 3 dB noise figure, and the IF bandwidth for the radiometric

III. CANDIDATE DESIGN IMPLEMENTATION

One goal of this effort is to identify a low-cost implementation that integrates the radiometer capability into a tactical communications terminal. The high cost components of a radiometer include the antenna and RF/IF front end electronics. However, the costs for square law detection, integration, and display are relatively minor. Thus, if the existing investment in the antenna and RF/IF front end subsystems could be used simultaneously by both the communications receiver and the radiometer, the potential for a cost-effective integration of the two functions could be realized. The use of a common antenna for the radiometer and communications receiver is desirable, not only from a cost viewpoint, but also because this assures the radiometer measures the attenuation over precisely the same path used by the communications terminal. In addition, a second antenna must not be accommodated.

Many tactical terminals are required to operate in an interference environment and, consequently, use spread spectrum techniques. In this application, the tactical terminal is assumed to operate with a frequency-hopped modem. In terms of spectral use, the communications receiver operates on a bandwidth segment that contains signal + noise, whereas the radiometer needs to operate on a bandwidth which contains predominantly thermal noise. The radiometer bandwidth must therefore be separated from the bandwidth containing the communication signal.

A. DESIGN CONCEPT

A block diagram of a typical tactical terminal design is shown in Fig. 5. The receiver front end uses a low-noise amplifier (LNA) to establish the system noise figure, and the signal is downconverted. In practice, two downconversions, the first with a fixed LO, are typically used. The frequency hopping of the signal is removed by the synthesizer, and the resulting narrowband signal is processed by the communication receiver.

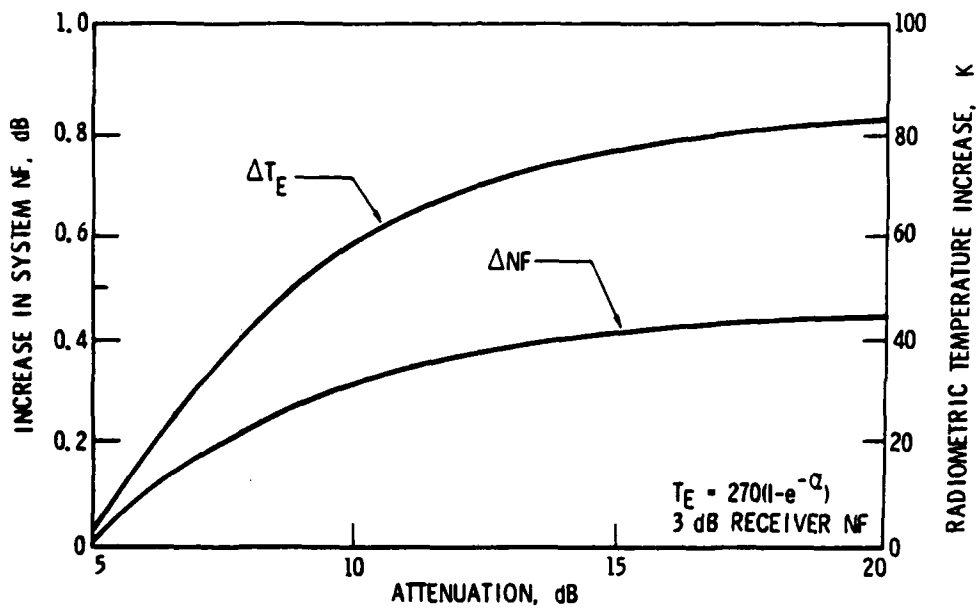

Fig. 4. Increase in System Noise Figure and Emission Temperature as a Function of Increased Attenuation Relative to a 5 dB Margin

The capabilities provided by the radiometer can be used either prior to terminal operation or simultaneously with terminal operation. When the radiometer is used prior to operation of the terminal, the measured propagation loss can be used to assess the potential of link closure and to establish an appropriate level of transmit power; such a capability has particular importance for terminals which strive to minimize detectability. During the operation of the terminal, other tests, such as bit error rate measurements, provide a measure of overall system loss. Under such conditions, the radiometric measurement of the propagation loss provides a separation of the individual loss components. For example, if the propagation loss measured by the radiometer is subtracted from the total system loss, other loss components, such as antenna pointing, can be assessed. The radiometric output augments the information derived from other measures of terminal performance.

A radiometric output provides a sensitive indication of the propagation loss. As an alternative, one might propose to measure the increase in the total system noise temperature induced by additional propagation loss; however, the precision required to make an adequate measurement of propagation loss from the total noise power far exceeds the accuracy which can be achieved in an operational environment. As an example, consider a system with a 5 dB weather margin that is waiting to operate in a rainstorm. When the rain slackens sufficiently, link closure is possible, and because the link is not established, error rate measurements of rain loss are unavailable.

In this case, propagation loss relative to the 5 dB margin is required. In Fig. 4, a comparison is made between the increase in the total system noise figure and the emission temperature increase for attenuation values, which exceed the 5 dB margin. The noise figure increased by 0.1 dB for a 1 dB increase in loss; measurements of such precision are difficult to achieve in a laboratory environment, let alone under tactical conditions. By contrast, a 1 dB increase in attenuation would result in a 17.6 K increase in emission temperature, which is easily detected by a crude radiometer. Thus, the radiometric measurement is a very sensitive measurement of propagation loss.

END

FILMED

5-85

DTIC