

DTIC
O

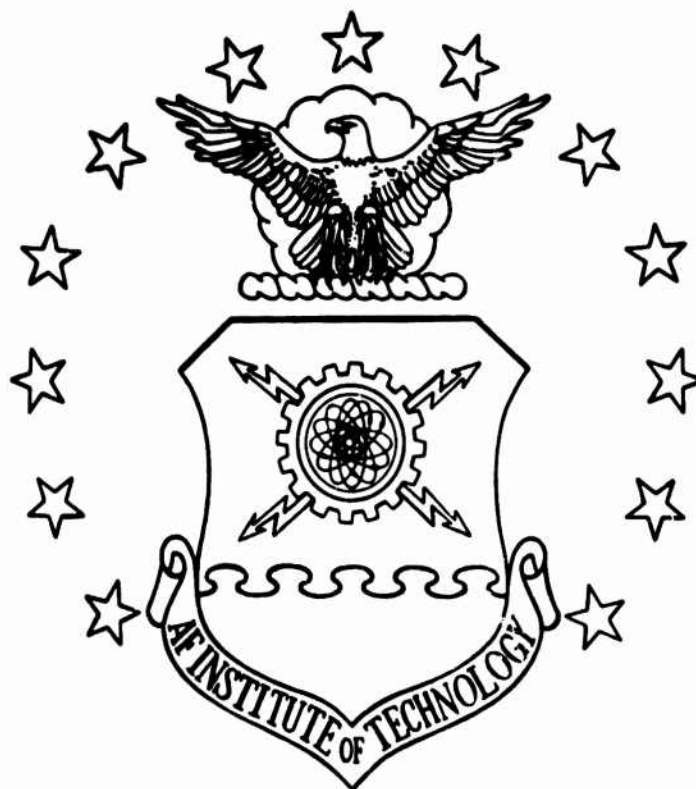

AD-A151 963

CREATING A MOBILE AUTONOMOUS
ROBOT RESEARCH SYSTEM (MARRS)

THESIS

Thomas E. Clifford Hubert G. Schneider
First Lieutenant, USAF Captain, USAF

AFIT/GE/ENG/84D-19

DTIC FILE COPY

This document has been approved
for public release and sale; its
distribution is unlimited.

DTIC
ELECTE
APR 02 1985
S
D
E

DEPARTMENT OF THE AIR FORCE
AIR UNIVERSITY

AIR FORCE INSTITUTE OF TECHNOLOGY

Wright-Patterson Air Force Base, Ohio

85 03 13 066

AFIT/GE/ENG/84D-19

CREATING A MOBILE AUTONOMOUS
ROBOT RESEARCH SYSTEM (MARRS)

THESIS

Thomas E. Clifford Hubert G. Schneider III
First Lieutenant, USAF Captain, USAF

AFIT/GE/ENG/84D-19

DTIC
SELECTE
APR 02 1985
S D E

Approved for public release; distribution unlimited

CREATING A MOBILE AUTONOMOUS ROBOT RESEARCH SYSTEM (MARRS)

THESIS

Presented to the Faculty of the School of Engineering
of the Air Force Institute of Technology

Air University

In Partial Fulfillment of the
Requirements for the Degree of

Master of Science in Electrical Engineering

Accession For	
NTIS GRA&I	<input checked="" type="checkbox"/>
DTIC TAB	<input type="checkbox"/>
Unannounced	<input type="checkbox"/>
Justification	
By _____	
Distribution/	
Availability Codes	
Dist	Avail and/or Special
A-1	

Thomas E. Clifford

First Lieutenant, USAF

Hubert G. Schneider III

Captain, USAF



December 1984

Approved for public release; distribution unlimited

Preface

The creation of MARRS-1 and the AFIT Mobile Robotics Laboratory was made possible through the energetic support of many individuals and organizations. In particular, we want to thank our thesis advisor Dr. Matthew Kabrisky and the Department of Electrical Engineering for providing the ultimate research environment where opportunities for self realization and true contributions to science and technology flourish. Additionally we thank Captain Rob Milne, Captain Lee Baker, Robert Durham, Orville Wright, Dan Zambom, Dick Wager, Charlie Powers, Stan Bashore, and Mary Elizabeth Dennis of AFIT/ENG; Leroy Cannon, and Steve Coats of AFIT/ENY; Ron Gabriel of AFIT/ENP; Carl Shortt, Ron Ruley, and Russell Murry of AFIT/RMF; our sponsor, Tim Anderson of AFMRL; Lt. Keith Carter of AFWAL/AADM-2; Amn. John Burns of AFIT/PA; SSgt. Robert Lofland of Det. 2 1361 AV Sq; Doug Sauer of SRL; Tom Meyer and Gordon Doughman of Motorola; Dick Parr, Abe Siff, and Clair King of Datametrics; and Dennis Van Deusen of Virtual Devices.

Many thanks also go to Lt. Randall Owen who started this new endeavor at AFIT and Captain James Holten, an AFIT Phd. candidate, for his suggestions and encouragement.

But most of all, we are especially grateful to our parents, wives, and children whose support and sacrifices have allowed this project to be "more than just a thesis."

Contents

	<u>Page</u>
Preface	ii
List of Figures	vi
List of Tables.	viii
Abstract.	ix
I. Introduction	I-1
Background.	-1
Objective	-2
Why MARRS-1	-3
II. Background issues of Mobile Robotics	II-1
Basic Requirements for a Mobile Robot	-1
Computer Hardware	-2
Computational Element Selection	-3
Microprocessor Features of Interest	-3
Mechanical Drive.	-6
Mechanical Device Performance	-6
Sensors	-7
Robotic Vision.	-9
Range and Direction Techniques.	-10
Triangulation	-10
Controlled Lighting	-10
Stereo Vision	-11
Stereo Convergence in an IC	-12
Range from Time-of-Flight	-12
Ultrasonic Sonar.	-13
Time-of-Flight Limitations.	-14
Robot Software.	-14
Flexibility thru Resources.	-14
Levels of Robot Programming	-15
Basic Functions Required.	-16
Quality Software.	-17
Programming Guidelines.	-18
Decision Making	-19
Deferred Data Items	-19
Resource Allocation	-20
Exception Handling	-20
High Level Language Programming	-21
Sensory Data Processing	-23
Sensor Error.	-23
What is a Robot	-24

III. MARRS-1 DESIGN	III-1
Overview.	-1
Familiarization with the AFIT HERO-1.	-2
What Could the AFIT HERO-1 Robot Do	-3
Deficiency Identification	-3
System Level Description.	-5
Design Philosophy	-7
Mechanical Design	-8
Drive Computer.	-8
Navigation Computer	-9
Nav Computer Hardware	-10
Nav Computer Software	-10
Optical Shaft Encoder (OSE) Subsystem	-11
Ultrasonic Sonar Subsystem.	-12
Software Development Support.	-15
IV. MARRS-1 System Integration	IV-1
Sideline Activities	-4
Robot Integrated Operation Test Plan.	-5
Test Range Environment.	-5
MARRS-1 Operating Modes	-6
Support Equipment	-7
Drive Computer Learn Mode Programs.	-7
Robot Test Procedures	-9
Data Collection	-11
Test Data Usage	-12
V. MARRS-1 Integrated Operation Test Results.	V-1
Minor Test Problems	-1
Mapping Algorithm	-2
Graphics Plots.	-4
Discussion of RIOT Results.	-16
VI. Recommendations for Future Work on MARRS-1	VI-1
Yet Another Computer for MARRS-1.	-3
Cooperation Needed in Mobile Robotics	-4
Conclusion.	-6
Bibliography.	BIB-1
Vita Lieutenant Clifford.	VITA-1
Captain Schneider.	-2
Appendix A: MARRSbug Operating System.	A-1
Appendix B: Extended Interrupt Handler	B-1
Appendix C: Mapper	C-1

Appendix D:	Navigation Computer Definitions. .	D-1
Appendix E:	Drive Computer Definitions	E-1
Appendix F:	Navigation Computer Schematics . .	F-1
Appendix G:	Navigation Computer Parts List . .	G-1
Appendix H:	HERO-1 to MARRS-1 Conversion . . .	H-1
Appendix J:	Lab Equipment, Hardware, Software.	J-1
Appendix K:	K-3 Encoder Installation	K-1
Appendix L:	Polaroid Range Board	L-1
Appendix M:	6800 Hex File Format	M-1
Appendix N:	Nav Computer Software User's Manual	N-1
Appendix O:	RIOT # 20 Raw Data Listing	O-1

List of Figures

<u>Figure</u>	<u>Page</u>
3.1 AFIT HERO-1 Built by Lt. Owen.	III-2
3.2 AFIT MARRS-1	III-6
3.3 MARRS-1 Control Structure.	III-7
3.4 Sonar Transducer Location.	III-13
4.1 Modified Front Wheel Assembly.	IV-2
4.2 MAPPER Heading Convention.	IV-9
5.1 RIOT Range Layout.	V-5
5.2 Location of Objects for Test with Objects.	V-5
5.3 Owen Thesis Test Range and Sonar Map . . .	V-6
5.4 Owen Thesis Coincidence Sonar Map.	V-7
5.5 RIOT #18: Straight One Sonar at a Time	V-8
5.6 RIOT #14: Zig Zag One Sonar at a Time	V-8
5.7 RIOT #19: Straight Two Sonars at a Time	V-9
5.8 RIOT #15: Zig Zag Two Sonars at a Time	V-9
5.9 RIOT #20: Straight Three Sonars at a Time	V-10
5.10 RIOT #16: Zig Zag Three Sonars at a Time	V-10
5.11 RIOT #21: Straight Four Sonars at a Time	V-11
5.12 RIOT #17: Zig Zag Four Sonars at a Time	V-11
5.13 RIOT #5: Straight One Sonar at a Time	V-12
5.14 RIOT #10: Zig Zag One Sonar at a Time	V-12
5.15 RIOT #4: Straight Two Sonars at a Time	V-13
5.16 RIOT #11: Zig Zag Two Sonars at a Time	V-13
5.17 RIOT #7: Straight Three Sonars at a Time	V-14
5.18 RIOT #12: Zig Zag Three Sonars at a Time	V-14

<u>Figure</u>	<u>Page</u>
5.19 RIOT #9: Straight Four Sonars at a Time	V-15
5.20 RIOT #13: Zig Zag Four Sonars at a Time	V-15
6.1 Unified AI/Robotics Model.	VI-5
G.1 CPU Control Bus.	G-2
G.2 CPU Address Bus.	G-3
G.3 CPU Data Bus	G-4
G.4 RAM/ROM Address and Data Bus	G-4
G.5 I/O Address and Data Bus	G-5
G.6 RAM/ROM Chip Enables	G-6
G.7 I/O Chip Enables	G-7
G.8 I/O Auxiliary Signals.	G-8
G.9 ROM Overlay RAM circuits	G-9
G.10 Serial I/O Ports	G-10
G.11 Buffered Sonar Signals	G-11
G.12 Sonar Timer/Range Board Interface.	G-12
G.13 Sonar Transducer Selection Circuitry	G-13
G.14 Sonar Transducer Relay Interface	G-14
G.15 Optical Shaft Encoder Timer/Counter Circuit	G-15
G.16 24 Pin Sonar Transducer Header	G-16
G.17 Dual Sonar Range Board 20 Pin Header	G-16
G.18 Optical Shaft Encoder Board 40 Pin Header.	G-17
H.1 Drive Computer I/O Upgrade	H-2
H.2 MARRS-1 Battery Configuration.	H-2

List of Tables

<u>Table</u>		<u>Page</u>
4.1	RIOT Configurations.	IV-7
4.2	MARRS-1 Straight Line Drive Computer Program	IV-8
4.3	MARRS-1 Zig-Zag Drive Computer Program . .	IV-8
4.4	RIOT Raw Data Format	IV-11

Abstract

↓
The Mobile Autonomous Robot Research System (MARRS-1) was created as the first of a series of autonomous vehicle prototypes for the Air Force Institute of Technology. The major accomplishment in developing MARRS-1 is the integration of Optical Shaft Encoder (OSE) data with Ultrasonic Sonar range and direction information to produce accurate environmental maps that are relative to the robot. The OSE and Sonar subsystems make up the most important part of MARRS-1's Navigation Computer. With these two subsystems and minimal additional software, mapping and obstacle avoidance become a reality. The thesis includes schematics, parts list, and software listings for the MARRS-1 Navigation Computer. Additionally, the mapping and navigation algorithms are shown implemented in the BASIC language with numerous example graphics maps created by the integrated MARRS-1 robot. Issues involved in solving mobile robotics problems are discussed. *Originator - supplied key words included:*

↓
p.1473 (last p.)

CREATING A MOBILE AUTONOMOUS ROBOT RESEARCH SYSTEM (MARRS)

I. Introduction

Background

A Nuclear, Biological, Chemical (NBC) contaminated environment presents a severe hazard for aircraft ground maintenance crews. A mobile autonomous robot capable of performing simple aircraft maintenance tasks could protect many lives from NBC exposure while allowing the Air Force to maintain its combat readiness.

In order for a mobile autonomous robot to function properly on a flight line, the robot must perform the following tasks:

- 1) Avoid obstacles (both static and dynamic),
- 2) Locate the appropriate aircraft,
- 3) Perform fueling and/or maintenance,
- 4) Return to previous work station.

Early AFIT efforts in mobile robotics were hampered by a lack of suitable hardware and software support (1:59-66). The acquisition of a Heathkit Hero-1 robot, laser barcode reader, and additional sonar sensors by 1Lt Randall J. Owen II for his thesis (2:1-3) was a great move forward for AFIT in mobile robotics. Before any autonomous vehicle can fuel its first aircraft there are however, several problems which

must be overcome. These problems may seem trivial but in fact are the limiting factors in mobile robotics today. Many of these problems are found in the Hero-1 as well as other robot systems:

- 1) Lack of robot software,
- 2) Combined error effects in the robot,
- 3) Reduced robot efficiency due to the dedication of resources for error compensation,
- 4) Understanding and reducing the amount of performance data.

Objective

This thesis is a follow-on effort to Lt Owen's thesis: "Environmental Mapping by a Hero-1 Robot Using Sonar and a Laser Barcode Scanner". The main objective of this thesis is to continue the development towards an autonomous robot capable of moving from one location to another while avoiding obstacles. However, the thesis effort is divided into the following sub-objectives:

- 1) Identify and eliminate design deficiencies in the AFIT HERO robot.
- 1) Establish a software development capability for the AFIT HERO robot.
- 2) Establish a library of robot programming software and algorithms.

- 3) Create and conduct tests that will identify system errors and provide figures of merit on robot performance.
- 4) Establish an AFIT mobile robotics laboratory.

Why MARRS-1

The HERO-1 robot has many design deficiencies (chapter III) that make it difficult to continue its use as a research robot beyond what has been done by Lt. Owen. The two greatest deficiencies of the HERO-1 are the front wheel design and the lack of online and offline software development capabilities. The ability to rapidly develop and debug software was seen as one of the most important improvements needed in the AFIT mobile robotics research environment. HERO-1 robot programmers are required to write programs in machine language, assemble the code by hand, then enter the code as hexadecimal numbers from a keypad on the robot. Programs once loaded on the robot may then be saved, for later use, on audio cassette at 300 baud. A better approach to mobile robot programming is necessary.

Although the HERO-1 is well endowed with sensors (a single three degree beamwidth ultrasonic sonar range finder, a 256 level light intensity sensor, a 256 level sound volume sensor, an ultrasonic motion detector, and wheel odometer) ,its abundant selection of sensors is thwarted by its lack of useful and user friendly software.

To make things worse, the HERO-1 robot operates in an open loop (no active feedback) mode. A quality mobile research robot was needed but could not be found commercially. Two options were available:

- 1) Build a mobile robot from scratch.
- 2) Improve the existing HERO-1 design.

The second option was taken resulting in a robot named Mobile Autonomous Robot Research System (MARRS)-1. This also resulted in the creation of the AFIT Mobile Robotics laboratory which initially came more as a necessity rather than as a conscious effort.

AFIT's mobile robotics research was being conducted in the Electrical Engineering Department's Signal Processing laboratory. Work space there was at a premium. A search for lab space and a mobile robotics test range resulted in moving the research effort to a building needing rehabilitation. Over a period of months of scrounging for equipment, furniture, and supplies, the new mobile robotics work area was in fact a laboratory. AFIT building renovation plans have identified 800 square feet for mobile robotics research.

II. Background Issues of Mobile Robotics

Basic Requirements for a Mobile Robot

If a robot is going to move about from one location (present position) to another (the goal), then several important criteria must be met. The robot must know its initial location and heading with respect to some reference point. The location of the goal must also be specified with respect to the reference point or to the robot's own position. Knowledge of the location of all objects around the robot and what the objects are may not be important. However, the locations of obstacles are significant for path planning. An object becomes an obstacle when it becomes apparent that the object lies or will lie along the robot's path towards the goal. This situation is analogous to a human that suffers from agnosia. The person is unable to identify what some objects are but is aware of the object's presence and can maneuver around them. Navigation can be accomplished in a timely manner only if position information can be gathered, coupled together, interpreted, and acted upon.

Four basic elements are required to create a robot that can maneuver its way around objects.

- 1) A computer (hardware) is required to process sensor data and to provide control logic to the robot subsystems.
- 2) A drive system is needed for mobility. The most common mobile robot drive systems are composed of digital

controlled DC motors turning wheels since articulate legs are very rare because of their complexity and expense (3:2). Feedback must be provided from the drive system to the computer to give vital information such as acceleration, velocity, distance traveled, and heading.

3) A variety of types of sensors are needed to provide the robot with far and near range obstacle detection, object identification, and sensory system cross-checks. These sensors, coupled with the drive system feedback give the computer the information necessary to maintain an accurate estimation of its current position and heading.

4) Computer programs (software) are needed to interpret sensory information, plan/execute required operations, and control robot subsystems.

Computer Hardware

Until a few years ago autonomous vehicles were unheard of in real life. The advent of the microcomputer has made fact possible out of fiction.

The two most important uses of a microcomputer in robotics are device control and data processing. In a dynamic environment, multiple computers may be employed to process data and control devices.

Several prototype robots with multiple computers operate under a master-slave principle. Generally the motion controllers act as slaves to the sensory

processors/interpreters. Communication between masters and slaves is handled by an interrupt scheme (4:212).

Computational Element Selection

Computational elements in a robot can be anything from a hydraulic valve to a multiuser/multiprocessor mainframe computer. For now, the discussion centers on digital microprocessors since most present day robotics projects are so based. It should be remembered, however, that there are many alternatives available for fulfilling a robot's computational needs.

Microprocessor Features of Interest

Although the following list of microprocessor features is not complete nor exhaustive in identifying a robot designer's needs, it does point to those features needing greatest consideration when choosing a microprocessor for an imbedded robotics computer application. The features are:

- 1 Existing software support;
- 2 Interrupt structure:
 - a. Nonmaskable interrupt;
 - b. Maskable interrupt;
 - c. Software or System interrupt;
 - d. Priority interrupt;
 - e. Buffered interrupts when masked;
- 3 Input/Output facilities;

- 4 Instruction set and addressing modes;
- 5 A Test and Set instruction for resource control;
- 6 Addressable memory space;
- 7 Hardware support chips:
 - a. DMA controller;
 - b. Memory management;
 - c. Numeric coprocessor for floating point operations;
 - d. I/O;
- 8 Special supervisor modes for system failsafe monitoring;
- 9 Processor compatibility with support chips/devices;
- 10 Minimum system and support cost; and
- 11 Development team familiarity with the chosen microprocessor.

Existing software to support the chosen microprocessor has to be the single most important factor used in the selection process since 90% of project costs historically have been for software development. By procuring commercial support software, in-house software development overhead is decreased and more resources can be directed toward robot specific software. Development team familiarity with a given microprocessor has been an overriding choice factor in a number of projects such as in the development of the Motorola 6808 based HERO-1 robot.

In reviewing the presently available microprocessors against the above criteria, the 280 microprocessor is the best choice (here at AFIT) mainly because of available hardware/software support. However, when not considering available support, the MC68000 family of microprocessors has the best feature set for robotics applications because (5,6,7):

1 Its memory oriented architecture (as opposed to register oriented) facilitates memory to memory transfers of data which is very useful for sensory data processing.

2 Sixteen Megabytes of memory may be directly addressed allowing for a mobile robot to carry with it a tremendous amount of instructions and data without the need for an external mass storage device.

3 A test and set instruction is provided for controlling access to shared resources in a multiprocess, multiprocessor, and/or interrupt driven environment typical of robot designs and applications.

4 Synchronous or asynchronous interfacing to external devices allows great flexibility to the hardware designer.

5 Any combination of processor registers may be saved or restored with a single instruction.

6 All program code is directly relocatable since all address references are added to a base register that is set to effect the relocation.

7 The UNIX operating system is widely used for MC68000 systems and has with it some very powerful features. However, the overhead in terms of memory usage and speed of execution may make this a negative feature for mobile robotics. Also, although UNIX is multiuser/multitasking, it is not optimized for the realtime computational environment required by robotics. It is, however, a very powerful operating system for software development.

Today's choice in the use of a particular microprocessor for a robotics application may not be tomorrow's choice. Designers must plan for an upward migration of requirements and capabilities and yet accomplish tomorrow's job today.

Mechanical Drive

A typical drive system of a robot utilizes a computer controlled DC motor capable of variable speeds in both forward and reverse directions. Motors are mounted on one or more wheels to provide steering and motion control.

Mechanical Device Performance (8:12-24)

Software routines that control mechanical devices must be designed with the following items in mind:

- 1 Servo systems must be stable over wide dynamic ranges.
- 2 Spatial resolution has finite errors (mechanical accuracy) and errors due to quantization.

- 3 Repeatability is more difficult when the mechanical accuracy of the robot is less than the accuracy of the sensory data used to modify the robot's action.
- 4 Repeatability will suffer from component wear and aging.
- 5 Errors will accumulate. Sensory data must be used to update mechanical device commands.
- 6 Compliance to a command may be dependent upon the mechanical loading of system components.
- 7 Compliance to a command may exhibit a hysteresis effect depending on the direction of arrival (such as an accumulated 360 degree turn from the right is really 365 degrees but coming from the left it is only 355 degrees).
- 8 Oscillations may occur if command compliance is too slow.

Sensors

Without sensors, a robot is nothing more than a Numerically Controlled (NC) machine (8:57). Sensors allow a robot's actions to be determined based upon the robot's sensory interpretation of the world.

Before a robot can move about and perform any function, it has to sense its surroundings. This information will allow it to compute a clear path of travel and prevent it from bumping into obstacles.

There are numerous types of sensors commercially available today for object detection and identification. These sensors range from the simplest contact switch to the most complex vision systems. Yet each sensor has its own limitations.

For example, a microswitch can be used to detect whether or not an object has made contact with the robot. However, it can not tell how much pressure is on the object nor the maximum amount of pressure that can be tolerated. A fragile item such as a flower might be crushed by a robot hand that lacks very low pressure touch sensors.

The sensing of position can be simulated through optical devices (9:71). The use of photo emitters and receptors can measure intensity of light as well as touch. Another method of simulating touch is through membrane contact surfaces. Many of these membrane sheets form an array of switches. The greater the number of switches used, the better the resolution will be. However, increasing the number of sensors means an increased amount of data which requires much more computing time (10:73). This holds true for sensors in any domain and not just touch sensors.

The sensors discussed thus far will only give the robot information about its immediate surroundings. If the robot is to maneuver around in some unknown environment then it must also have access to sensory information about objects at much greater distances. What is required is some form of vision.

Robotic Vision

Moravec sized up the state of the art in robotic vision by saying, "There's a handful of techniques for robot vision that sort of work, but none that works spectacularly well. We're all still groping in the dark (11:73)." As robotic vision goes, so goes mobile robotics.

Jarvis (12) points out that the human visual system uses many techniques to extract range information about the objects in the field of view and which may be used by robots. These include; changes in brightness level, binocular convergence (the inward pointing of the eyeballs which is inversely proportional to the range of the object), stereo disparity (the closer the object the greater the disparity), vertical position in the visual field (closer objects are usually lower in the field of view), diminution of size with distance, occlusion clues and outline continuity (complete objects look closer than partially obscured ones).

Range and Direction Techniques

The principal range with direction vision techniques used by robots are triangulation, surface orientation from image brightness, stereo disparity and binocular convergence, ultrasonic sonar, radar, and laser time-of-flight (12).

Triangulation

Triangulation techniques use a narrow beam of light and a camera that is physically displaced from the light beam source. The camera tracks the light beam as it is swept across the field of view. The azimuth and elevation (pointing direction) of the camera and light beam are recorded during the scan. Using Euclidean geometry, a three dimensional picture (3-D) is generated from the camera's 2-D picture and the direction information. Since the camera is physically displaced from the light beam, it can see points in the scene that the light beam can not and vice versa. This lack of common origin causes problems for scene interpretation and is only used in controlled situations.

Controlled Lighting

Surface orientation from scene brightness gives range information indirectly. Using high contrast controlled lighting, edges of objects are defined by looking for a change in brightness between adjacent pixels (picture elements). Keller (13:123) indicates that the generally

accepted minimum pixel count for robotic vision purposes is 256 horizontal by 256 vertical with 256 levels of brightness (grey scale). This pixel brightness comparison creates a tremendous computational burden on a robot and is normally performed remotely by special computers. Once the edges of an object are defined, the relative range of the object is estimated using occlusion clues and outline continuity rules.

Stereo Vision

The stereo disparity and binocular convergence combine the techniques of triangulation and edge detection in that the pixels of two physically separated cameras are matched. The angular position in the field of view of each camera for a specific common point will be different from one camera to the other because of the physical separation of the cameras. The difference between the angular position of the two views is equivalent to the amount of inward turning of the eyes in the human visual system which is inversely proportional to the range of the common point. The greatest problem with this technique is being able to distinguish which pixel of one camera is the same point in the other camera (13:123). This problem can be compounded when the picture being processed has a periodic pattern such as a brick wall or a fence with a vertical or horizontal pattern. In such situations, the computer that is correlating points between pictures gets confused and usually can't solve the problem.

Stereo Convergence in an IC

Iverson (14) describes an integrated circuit (IC) that has 23 pairs of light detectors lined up in two rows with each having its own microlens bonded directly to the chip carrier. The IC is placed behind the lens of a single camera and is capable of doing edge detection and range calculations using stereo disparity and binocular convergence techniques passively without using special lighting. Such an equipped camera system does not suffer from most of the problems of the previous paragraphs and holds great promise for freeing mobile robots from the lab. The accuracy of the system depends on the distance to the object being sensed and the focal length of the imaging lens used on the camera.

Range from Time-of-Flight

Ultrasonic sonar, radar, and laser time-of-flight techniques rely on the propagation of energy (sound, electromagnetic, and light) through air to an object that reflects the energy back. The time to make the trip is proportional to the range of the reflecting object. The problem with these techniques is that the power of the return energy received by the sensor decreases at a rate proportional to the range to the fourth power. Hence, an increase in range coverage requires a tremendous increase in transmitted power which may be beyond safe levels.

Ultrasonic Sonar

Laser light and television systems can provide distance information and much more. However, these systems tend to be very complex and expensive (10:180). A low cost alternative approach is to use an ultrasonic device (like the ones found on the Polaroid Land cameras.)

A high frequency "chirp" is transmitted from the sonar device. A counter keeps track of the time between the instant the signal is transmitted and the time the signal returns. The Polaroid sensor for example has a range of 0.9 feet to 35.0 feet (15:15). Although this sensor can provide the robot with limited information about its surroundings, the object's inclination and geometry could affect the quality of the returned signal. Better results can be obtained with multiple ultrasonic sensors mounted on the robot in different directions (10:183).

Owen (2) showed that mobile robot obstacle avoidance was possible by reducing the amount of information to be processed by the use of multiple ultrasonic sonar sensors giving the range to the closest obstacle at known directions. He also showed that a crude map of the robot's environment could be made from robot position and sonar information.

Jarvis (12:135) indicates that obstacle detection and robot navigation are good applications for ultrasonic sonar because of their low cost and ease of use.

Radar range finders have given way to laser time-of-flight range finders since the beam of the laser is very narrow and can be precisely controlled. Since the path traveled to the object is done at the speed of light, the supporting instrumentation must be capable of 30 nanosecond resolution for range accuracy of 1 centimeter. This requirement pushes the present limits of economical electronics. Jarvis (16) feels that such laser range finders used with standard single camera 2-D vision systems could yield sufficient quality for robotic scene analysis.

Robot Software

Robotics research, development, and applications require advanced engineering and technical skills (8:55). The key element here is computer control via software. The sophistication of the robot's software will vary directly with the complexity of the task to be performed. What distinguishes robot software from other software is the robot's interaction with the real world. The software must account for numerous possibilities and outcomes of situations.

Flexibility thru Resources

Computer software enables a robot to perform a myriad of tasks. However, there is no standard or universal robot programming language. For every unique robot, there is a

unique set of instructions to control that robot.

Flexibility in robot programming is found in the basic operations the robot can perform as determined by its resources. A robot's resources are:

- 1 algorithms;
- 2 data;
- 3 computational power;
- 4 storage capacity;
- 5 commandable devices (motors, relays, servos, wheels, arms, end effectors, and other special purpose devices);
- 6 sensors (gathers or verifies data on system operation or the environment);
- 7 and master/slave connections with other robots, machines, systems, computers, and/or humans.

Levels of Robot Programming

There are three distinct levels of robot programming: system, task, and operator (8:55). System programming provides the lowest level of routines to control robot resources and interfaces between resources. Task level programming is done as high level calls of the lower system level routines. Operator programming may consist of loading programs into the robot, adding required or optional data, turning the robot on or off, teaching the robot a sequence of operations to be remembered for later use by means of a

"teach box" or "pendant", or physically leading the robot by the hand thru the required operation while having the robot memorize the sequence for later use. Each level of robot programming requires a different level of skill and understanding.

Basic Functions Required

The set of required basic functions for a robot are (8:57):

- 1 Computation:
 - a. analytic geometry is most useful;
 - b. coordinate representation and transformation;
 - c. vector operations (dot product, cross product, scaling, normalization, and linear operations);
- 2 Decision (conditional branch based on processed sensor data):
 - a. sign test (+, -, 0);
 - b. relation (<, >, =);
 - c. Boolean (on, off, true, false, 1, 0);
 - d. bit pattern given a reference pattern;
 - e. set operations (member, nonmember, subset, empty set);
- 3 Communication (internal and external);
- 4 Movement;

- 5 Sensor data gathering; and
- 6 Sensor data processing.

Quality Software

Quality software development comes from discipline in following an established methodology. Top down structured programming can produce software that is (8:62):

- 1 correct (hard to determine);
- 2 reliable (no detected errors);
- 3 valid (meets specifications and is suitable for the job);
- 4 resilient (degrades gracefully when things go wrong, checks for errors, and provides recovery routines);
- 5 usable (shows consideration for human factors consistent conventions, few if any arbitrary codes/names, through diagnostics and error messages);
- 6 clear (design structure apparent from program listing, meaningful names, use of well known algorithms, frequent and effective comments, modular structure);
- 7 maintainable/modifiable (a by-product of clarity, changes due to detected errors or system changes are easily incorporated);

- 8 generalized (performs over a wide range of input values, modes, and use);
- 9 portable (hardware specific and software dependent features are isolated for easy change to another computer system);
- 10 and is testable (step by step testing is possible due to simple structured algorithms).

Programming Guidelines

The following guidelines for structured programming provide a methodology for program development (8:69):

- 1 Program in small modules.
- 2 Comment programs telling what and why things are done and what assumptions exist if any.
- 3 Don't misuse the instruction set or software language.
- 4 Don't write self modifying programs.
- 5 Avoid complex statements - break them up into smaller parts.
- 6 Use indentation and a format that makes listings more readable.
- 7 Avoid negative Boolean logic. Reversing an if - then clause allows dropping a NOT in front of an expression.

- 8 Use meaningful names for variables, constants, and procedures.
- 9 Make modules that do not interfere with the code or data of other modules.
- 10 Uncommented code that works is better than commented code that doesn't work, until it comes time to modify the code. Comments should clarify. Clarity is its own reward.

Decision Making

A major part of a robot control system is decision making. The more decisions that can be deferred until run time, the better the robot program can be adapted to changing task requirements. There are four kinds of decisions that may be deferred until run time (8:74):

- 1 What initial data items are required.
- 2 How to allocate resources.
- 3 How to coordinate concurrent processes.
- 4 How to handle exceptions.

Deferred Data Items

Determining deferred data items may require communication with an external computer system, locating an index mark or calibration jig for sensor alignment, or even human interaction with the robot computer and/or sensors.

Resource Allocation

Resource allocation becomes a problem when two or more processes require the same resource. This still may be deferred past the start of run time to the concurrent process coordinator to resolve once the resources are requested during program execution.

The concurrent process coordinator switches the attention of the central processor and possibly other system resources between processes by use of a semaphore or Dijkstra flag. In multiple processor, multiple process, and/or interrupt driven robots, the use of special hardware (or a software instruction like the afore mentioned MC68000 test and set instruction) may be required to insure resolution of resource allocation conflicts. The coordinator must never allow a situation to exist where two processes or processors have been allocated resources and will not release them to another and yet can not proceed until a resource controlled by another is obtained. This is the classic deadlock or deadly embrace.

Exception Handling

Exceptions are either predictable or unpredictable (8:77). Predictable exceptions occur when a verification step returns false such as a mobile robot not finding a position update marker as planned. Unpredictable exceptions occur during well defined procedures. These are hardware

failures or the selection of a software path that was not tested and has an error. Software failures are best treated with preventive measures earlier discussed. Hardware redundancy, parity bits, checksums, cyclic redundancy check characters (CRC), message sequence numbers, send and receive addresses, and error detection/correction codes are possible ways to decrease or handle unpredictable exceptions.

It may be advisable to disable the robot on certain exceptions. Time-outs may be implemented in hardware or software to disable a robot if a "keep alive" signal is not updated every so often. If disabled by a time-out, the robot should only be restarted by a special manual or automatic procedure. Robots should have deadman and panic switches to protect both humans and equipment.

High Level Language Programming

Programming should be done at the highest level of language possible consistent with the needs of efficiency and clarity. It is imperative that task level programming discussed earlier be done in an interpretive or halttable/restartable language so as to be able to debug programs while running on the robot. Software facilities required for program debugging include utilities to:

- 1 Up-load/down-load code from an off-line (off-robot) software development system to the robot;

- 2 Relocate code in memory;
- 3 Link modules;
- 4 Allow Symbolic debugging;
- 5 Set/reset breakpoints; and
- 6 Single step program execution.

Programming languages used should conform to the structured programming guidelines. Possible languages include:

- 1 Assembly language in the processor's instruction set;
- 2 The C programming language;
- 3 Structured FORTRAN;
- 4 PASCAL;
- 5 ADA;
- 6 LISP;
- 7 PROLOG; and
- 8 FORTH.

Many other good languages exist, but the mentioned languages have virtues which make them desirable for program development and debugging. There are also many robot specific languages but are usually processor and hardware dependent. These can, however, be used as a basis for developing new robot languages if concern for quality software design is maintained.

A quality editor/word processor software package is a must for software development, documentation, and reporting.

Sensory Data Processing

The only arguments against the use of a particular sensor are its cost in terms of software overhead, required computing power support, time to process the sensor's data, fit on robot, weight, robot capability without the sensor (which may be an argument for the sensor), external equipment/personnel support required to use this sensor, and money (8:25).

The major robot sensor categories are:

- 1 Proprioceptors (sense position);
- 2 Touch;
- 3 Proximity;
- 4 Range;
- 5 Force;
- 6 Movement;
- 7 and Vision (really only a subset of the vision that humans experience).

Sensor Error

Sensor errors may be due to changes in sensor characteristics over time, quantization error, or sensor susceptibility to noise of some form. Filtering techniques may therefore have to be incorporated to compensate for or minimize the effects of noise.

Crowley has proposed a computational paradigm or model for three dimensional scene analysis (17). He explains that

multiple sensor systems may be used to gather information about a robot's environment and a sensor model of the environment developed. Models from many sensors are combined to create a combined or composite model that can change with a dynamic environment. This composite model is then used to solve a mobile robot's problem of global navigation, local navigation, and position estimation (18).

What is a Robot

A robot is a device that performs functions normally ascribed to human beings, operates with what appears to be almost human intelligence, or is a mechanism guided by automatic controls (19:744). Industrial robots generally consist of an arm bolted to a platform with an end effector (gripper, spot welder, drill, or special tool) affixed and which is controlled by a computer. A robot is distinguished from a Numerically Controlled (NC) machine (such as an automatic lathe) in that a robot's actions are determined by sensor feedback and not just a sequence of computer instructions. Most mobile robots still remain in research labs because of the demanding requirement to have some form of vision to allow obstacle avoidance and object identification to allow a solution to the mobile robot navigation problem. New forms of vision based on range and direction information may soon allow mobile robots to function in environments previously requiring human workers.

III. MARRS-1 Design

Overview

One of the major efforts of this thesis has been to develop hardware and software to control and communicate with the AFIT MARRS-1 robot. Additionally, three important steps were taken to improve the robot. First, the robot was taught and run thru a simple sequence of operations to identify the errors involved with moving the robot in various directions. Second, the robot was then modified to make optimum use of its sensors and to eliminate where possible the errors identified in the first step. And thirdly, a software development system was established to aid in the design, testing, and maintenance of the robot and its subsystems.

After a period of hardware evaluation, mechanical redesign, fabrication, and electronics upgradeing was completed, the remaining task involved many iterations of program development, testing, data analysis, and program modification based on test results.

A series of Robot Integrated Operation Tests (RIOTs) were then performed that have great value in many key areas. The tests establish a benchmark that can be used as a point of reference for further work. In addition, if the errors in a particular device are consistently similar to previous test cases, then error compensation is relatively simple.

If on the other hand, the errors are random, then much more emphasis must be placed on multiple sensor feedback. The tests may be expanded as the mobile robot project continues and should be updated as automated tools are made available (or developed). The objective of the tests should not only be to demonstrate a capability but to also identify deficiencies that may exist in the robot and to what extent.

Familiarization with the AFIT HERO-1 Robot

Before a prospectus for this thesis could be submitted, some familiarity with the AFIT HERO-1 robot built by Lt. Owen was necessary (see figure 3.1). What could the robot do? What would be the next step in developing a truly autonomous mobile robot? Could the robot be made autonomous? The answers to these questions would be the driving force in determining the direction of this thesis.

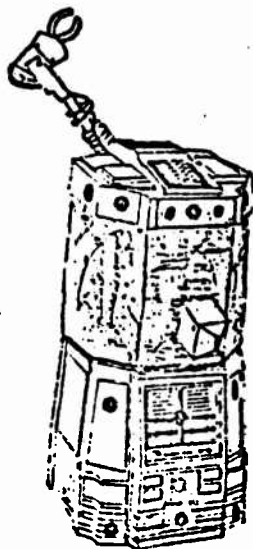

Figure 3.1 AFIT HERO-1 Robot Built by Lt. Owen

What Could the AFIT HERO-1 Robot Do?

The AFIT HERO-1 robot had an arm with 145 angular degrees of movement, a wrist with two axis of motion, and a two claw gripper. Locomotion was developed from a tricycle gear wheel configuration with the front wheel the only wheel actively propelled and steered plus or minus 90 degrees from center. The drive of the front wheel had three speeds in both the forward and reverse directions. There were two levels to the body with the top level being able to turn plus or minus 178 degrees. Additionally, the robot had a Votrax SC01 speech synthesizer, a single three degree beamwidth ultrasonic sonar range finder in its head with separate transmit and receive transducers, a calendar with clock, a 256 level light intensity sensor, a 256 level sound volume sensor, and an ultrasonic motion detector. Lt Owen had added a laser barcode reader and 15 Polaroid type ultrasonic sonar range finder transducers. The robot had an impressive list of resources for mobile robotics research, could make crude maps of its environment, and move about randomly without hitting obstacles under self control. Yet, the AFIT HERO-1 robot had some major deficiencies.

Deficiency Identification

Initial investigation into the opportunities for improving AFIT's mobile robotics research revealed the following:

The ability to rapidly develop and debug software was seen as one of the most important improvements necessary for the AFIT mobile robotics research environment.

The front wheel design of the HERO-1 robot needed to be improved since the steering gearbox bearings wore excessively over a short period of robot use. The bearing wear and the additional weight from the laser barcode reader distributed high in the robot's body caused the robot to be mechanically noncompliant, nonrepeatable, and top heavy (unstable). Motion of the robot now became random since commands to the stepper motor controlling the steering of the front wheel, were sent from the robot's computer and assumed to have been obeyed, when in fact, it was very easy for small impeding forces to withstand and overcome the torque of the steering stepper motor. Thus, robot steering and position estimation algorithms were defeated. This condition could have been avoided in part by determining the position of the steering shaft explicitly with a sensor and implementing a closed loop feedback system.

The AFIT HERO-1 robot Polaroid ranging system was not as fast in gathering data as it could have been since only one transducers could be used at a time.

The creation of a sonar range map from data gathered by the AFIT HERO-1 robot required undesirable human intervention to:

1. Determine the robot's heading for each sonar sample period.

2. Provide a robot position correction factor for each sonar reading. The barcode that was read by the robot was taped to the floor and was from one and a half to two feet away from the center of the robot. Thus, position of the robot was loosely based on the number appearing on the barcode. The position of objects in the test environment was based on data from the sonar system which was not firmly referenced to the barcode taped to the floor.

3. Draw the two dimensional (birds eye view) map post mission in a form useful to humans from sonar data, barcode position information, and notes taken by human observers during the mission (or test run).

The AFIT HERO-1 robot was then redesigned, rebuilt, and renamed the AFIT Mobile Autonomous Robot Research System (MARRS-1) and is shown in figure 3.2.

System Level Description

The overall system structure for control of MARRS-1 is shown in figure 3.3. Note that the vertically integrated control structure from the external computer to the Nav Computer to the Drive computer is only one of many configurations possible. The RIOTs of chapter 5 used this structure minus the control shown from the Nav Computer to the Drive Computer.

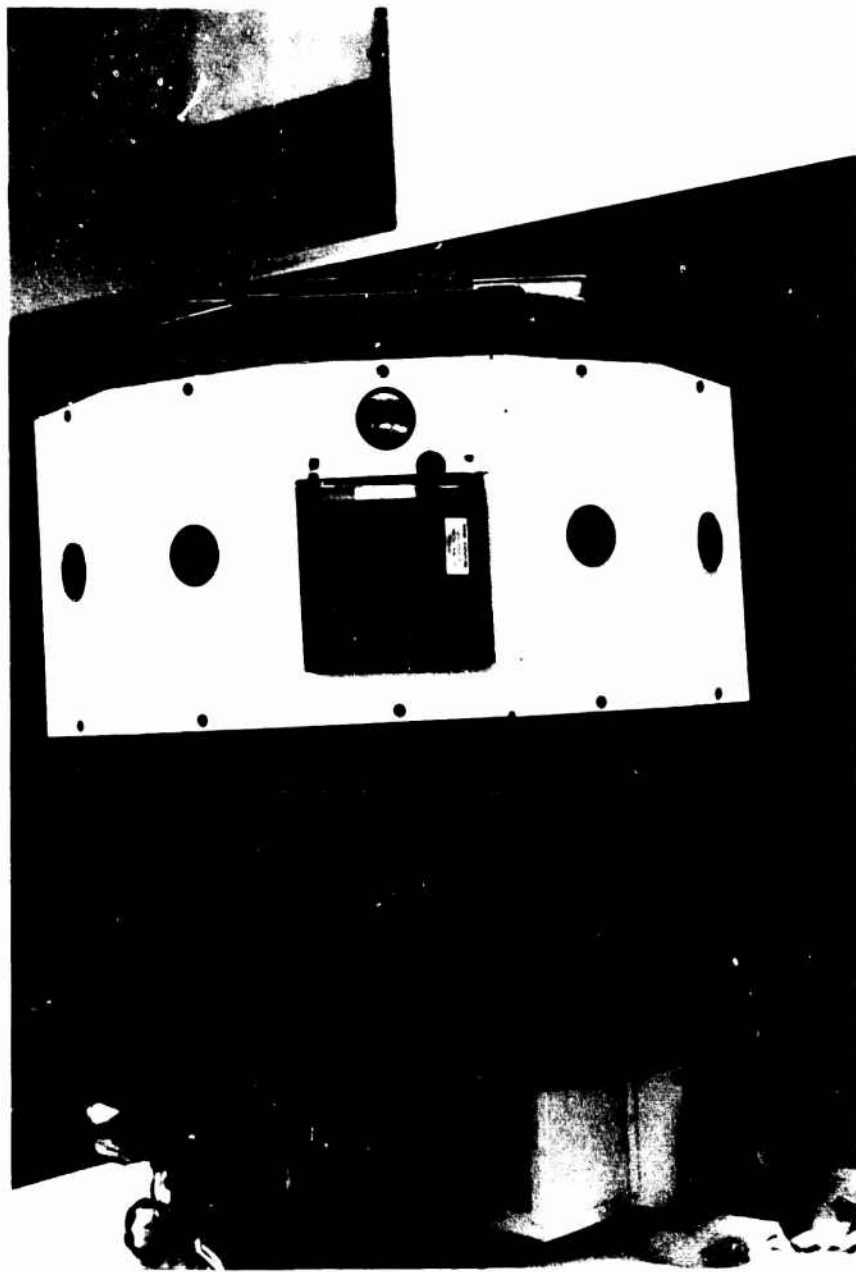

Figure 3.2 AFIT Mobile Autonomous Robot Research System (MARRS-1)

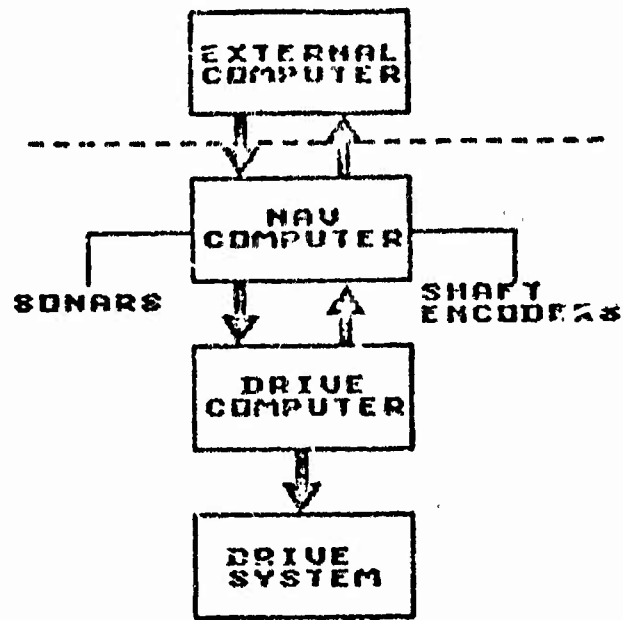

Figure 3.3 MARRS-1 Control Structure

Design Philosophy

Several key factors have molded the design of MARRS-1 into its final form. The first and foremost important design criteria was: Never discard a capability, only add to or enhance the original design. The second design criteria was to treat all system components and sub-elements as black boxes with standard interfaces (in this case serial RS-232). Modularity and expansion was always kept in mind as systems were designed and developed. Hardware implementation of a given task was always chosen over software (if a trade-off existed) to alleviate unnecessary burdens from the CPU.

Mechanical Design

The MARRS-1 robot is 29 and a half inches high, 21 and a half inches in diameter at its widest point, has two decks with 12 sides each, an improved tricycle configuration with a front wheel only drive system, separate shafts for each rear wheel, and a low slung 8 gel cell battery compartment. It has retained all the features of the HERO-1 robot except those modified to improve performance and the arm. The arm was intentionally left off MARRS-1 since the intent is to work toward solving mobile autonomous robot problems and not fixed arm problems. Once a good autonomous mobile platform has been developed, it will become desirable to add a quality robot arm with special end effectors. The twelve side design grew out of an attempt to have symmetrical sonar coverage at two levels erroneously thinking that the beamwidth of the Polaroid sonar transducers was 30 degrees when they are more like 10 to 15 degrees. The twelve side design impact on the sonar system will be discussed later.

Drive Computer

The original HERO-1 contained a MC6808 computer system with no RS-232 serial capabilities. The Virtual Devices Inc. MENOS-1 MC6801 upgrade CPU board enhanced the HERO-1 and gave it RS-232 capability (at 300 baud however) and tremendous new programming possibilities. The MENOS-1 ROM was modified to support 9600 baud rate communications

(see Appendix E). It is now possible to program the Drive Computer in the C language, in Virtual Devices tokenized Vamp language, in HERO-1 learn mode (teach pendant), in HERO-1 Robot language, and in 6801 Assembly language (a superset of the 6800 family with internal 16 bit operations). The Drive Computer (Menos I upgraded HERO-1 computer) is described in Virtual Device's Menos I user's manual, Virtual Devices Robo C user's manual, Heathkit's HERO-1 documentation, and in Appendix E.

Navigation Computer

The Navigation Computer is the keystone of MARRS-1. It controls both the Optical Shaft Encoder Subsystem and the Sonar Subsystem.

Serial RS 232 communication links are provided from the Nav Computer to both the Drive Computer and an external computer. Programs can now be cross assembled and downloaded from an external computer via serial ports to either the Nav or Drive computers on the MARRS-1 robot. In addition a third serial interface connects the Nav Computer to a laser 3 of 9 barcode reader enabling MARRS-1 to run software developed by Lt Owen. However, the laser barcode reader was not used for the Robot Integrated Operation Tests (RIOTs) (chapters IV and V).

Nav Computer Hardware

The digital portion of the Nav Computer is centered around Motorola 6800 family devices (see Appendices F and G). The operating system fits entirely on an 8K ROM with room to spare. An additional 8K ROM is located in parallel with the base page 8K RAM. System initialization software and page select circuitry load into the base page 8K RAM the contents of the base page 8K ROM after any hardware reset or call of the subroutine labeled ROMLAYRAM. A full contiguous 48K of static RAM exists on board. Input and output devices are memory mapped as is the case with all Motorola 68XX, 68XXX devices.

Nav Computer Software

MARRSBUG (see Appendix A and D) is an interrupt driven, heavily modified serial version of Motorola's MIKBUG and American Microsystem's PROTO operating systems. Data from the Nav Computer's Sonar and Optical Shaft Encoder subsystems is constantly being updated by a maskable hardware interrupt handler and made available to any user programs that run on the Navigation Computer. Hence, the net effect of the MARRSBUG interrupt driven data acquisition system is transparent to the user. The operating system is flexible enough to allow changes to vectors and constants which are loaded into system RAM on power up. An important feature of MARRSBUG is that on power up, the system performs a RAM check to verify where

the largest contiguous block of good RAM is located and updates the system RAM vectors appropriately. Additionally, numerous callable subroutines, software interrupts, and system utilities exist within the ROMs to aid the development of application programs for the Nav Computer (see Appendices A, B, D, and N).

Optical Shaft Encoder (OSE) Subsystem

The OSE Subsystem is perhaps the most important of the two Nav Computer subsystems (although one subsystem cannot perform to its utmost without the other). A 1200 count per revolution OSE is placed on the shaft of each rear wheel (two independent shafts) and on the front wheel steering shaft. By maintaining the distance traveled by each rear wheel, both heading and position information (relative to initial heading and position) are readily obtainable by calculating simple trigonometric equations (see Chapter V). The instantaneous steering position of the front wheel is maintained by subtracting the clockwise and counterclockwise counts of the front wheel steering OSE.

Cumulative counts are required to integrate this sensor data into the Navigation Computer. Thus, an incremental encoder was chosen. The Datametrics K3 encoder (see Appendix K) provides both incremental pulses and two channels which are 90 degrees out of phase with each other. With the proper interface circuitry,

this phase relationship enables the robot to distinguish between forward and reverse motion of each rear wheel.

A Motorola 6840 Programable Timer/Counter chip, in conjunction with a DM9602 dual precision one shot multivibrator, provides an optimum circuit to interface each OSE with the CPU (see Appendix G, Figure G.15). By using a 6840 as a counter (of which there are three 16 bit down counters on each chip) the burden of keeping track of continuously rotating wheels is removed from the CPU.

The DM9602's determine wheel direction (forwards or backwards). This is accomplished by testing for a low signal on one OSE channel and a negative transition on the other OSE channel. The 6840's act as divide by 64 counters which equates to one inch of wheel travel. When this distance has been reached, an interrupt is generated and a variable counter in system RAM is incremented (cumulative counts). Since the 6840 is programable, this divide by XX value may be modified to suit the user's scale factor and precision needs (see chapters V and VI).

Ultrasonic Sonar Subsystem

The AFIT MARRS-1 robot utilizes a simple vision system to aid in the solution of the mobile robot point to point navigation problem. The system acquires range and direction information from 32 polaroid sonar transducers attached to the robot's exterior.

Figure 3.4 illustrates the placement of 24 of these transducers on the robot as seen from an overhead view.

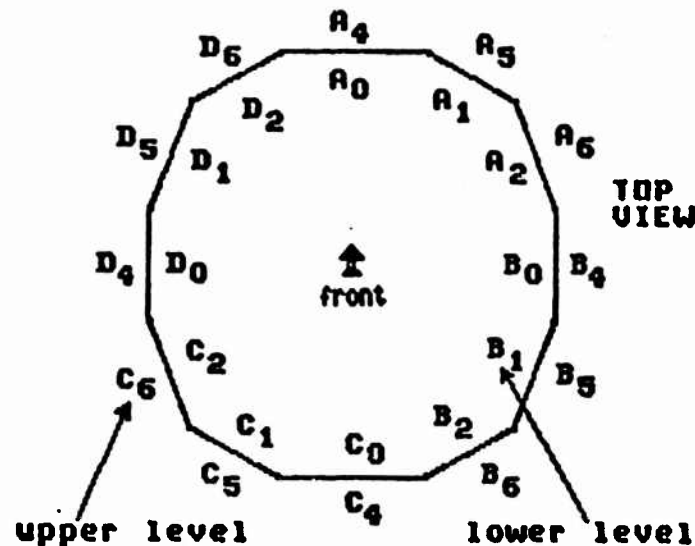

Figure 3.4 Sonar Transducer Locations

The robot's sonar sensors are divided into two different groupings by physical location on the robot or into four different groupings according to their attachment to one of four sonar range boards (Group A, B, C, or D). The lower body deck houses sonar transducers labeled A0, A1, A2, B0, B1, B2, C0, C1, C2, D0, D1, and D2. The upper body deck is comprised of sonar transducers labeled A4, A5, A6, B4, B5, B6, C4, C5, C6, D4, D5, and D6. There are an additional eight transducers in the head of the robot but

are not used in the RIOTs (Chapter V, Chapter VI). The selection of these eight transducers is however supported in the MARRS-1 operating system. The lower and upper body decks have 12 equal sides. Each side points 30 degrees away from its two neighbors on the same deck. The drive computer can rotate the upper deck plus or minus 178 degrees by controlling a stepper motor. Each sonar transducer is electrically connected to one of four sonar range boards (Sonar Board A, Sonar Board B, Sonar Board C, and Sonar Board D) by means of coaxial cable to one of 32 dual inline package (DIP) relays. Transducer selection is accomplished by energizing a DIP relay.

Only a maximum of four sonar readings are valid during a sonar sample period (one from each sonar range board). If multiple paths exist between a range board and its associated transducers then direction information is forfeited and maximum detection range is attenuated. It may be useful however to energize more than one transducer at a time and establish a minimum distance for obstacle avoidance. In this mode of operation, a full 360 degree coverage can be obtained each sample period if the user is willing to disregard the direction information. Distance information can be obtained from four mutually exclusive quadrants with one quadrant covered by each range board by turning MARRS-1's upper deck 15 degrees clockwise.

Scan patterns may be established to give discrete 360 degree coverage (with individual readings corresponding to each 15 degree segment) by selecting only one transducer of six attached to a range board. Range readings are taken from one, two, three, or four range boards during a sample period and then a different combination of transducers are selected during subsequent sample periods until receiving range readings from all 24 transducers.

By carefully choosing the transducers selected, separations of 90, 120, or 180 degrees between selected transducers may be achieved during each sample period when four, three, or two range boards are used during the sample period respectively so as to minimize the possibility of intersonar interference.

Software Development Support

An H89 running CP/M was chosen to do the cross assembly and program development due to the large amount of software supported by it and the abundance of H89 and CP/M systems at AFIT. A number of cross assemblers (running under CP/M) were found for the 6800 family of processors. Two of the cross assemblers were even in the Public Domain. In contrast, it was difficult to even find a 6800 based system to do software development work on for the existing HERO-1 computer let alone the software tools such as assemblers, compilers, and editors to do the job.

Most software development efforts for MARRS-1 took advantage of Virtual Devices Robo C compiler and Robo Assembler.

The next best alternative to the nonexistent universal robot programming language was to develop a library of robot software routines. These are generic in nature so that they may be combined to form larger modules of software. A MARRS-1 Nav Computer user manual is provided in Appendix N. Software provided by Virtual Devices for Menos I, Robo C, and Robo Assembler contain many excellent routines for controlling the original HERO-1 resources and the 6801 upgraded Drive Computer. However, autonomous operation of MARRS-1 will require integrated control of the Nav Computer, Drive Computer, subsystems, resources, and possibly sensors and computers yet to be developed.

IV. MARRS-1 System Integration

Once the MARRS-1 design was completed, a number of projects were tackled in order to bring the robot to a point where it could be tested as a system. Specifically:

1. The new two deck, twelve sided body, battery compartment, reinforced front wheel, and rear wheel assemblies were fabricated by the AFIT Shop Personnel.

2. The robot was painted red white and blue so as to create interest in the goals of the thesis and for patriotic impact.

3. All electrical wiring for the original HERO-1 was replaced with longer cables since the electronics were now mounted on swing out doors to allow ease of access for modification or maintenance.

4. Operation of the robot with the original HERO-1 electronics and new wiring was verified before installing the MENOS-1 6801 upgrade computer. It became evident that the modification to the front wheel (see figure 4.1) had made the robot's movements repeatable and compliant to program command. On six different test runs the robot was able to return to the same spot (within three inches) after going over a 50 foot figure eight course in the HERO-1 learn mode.

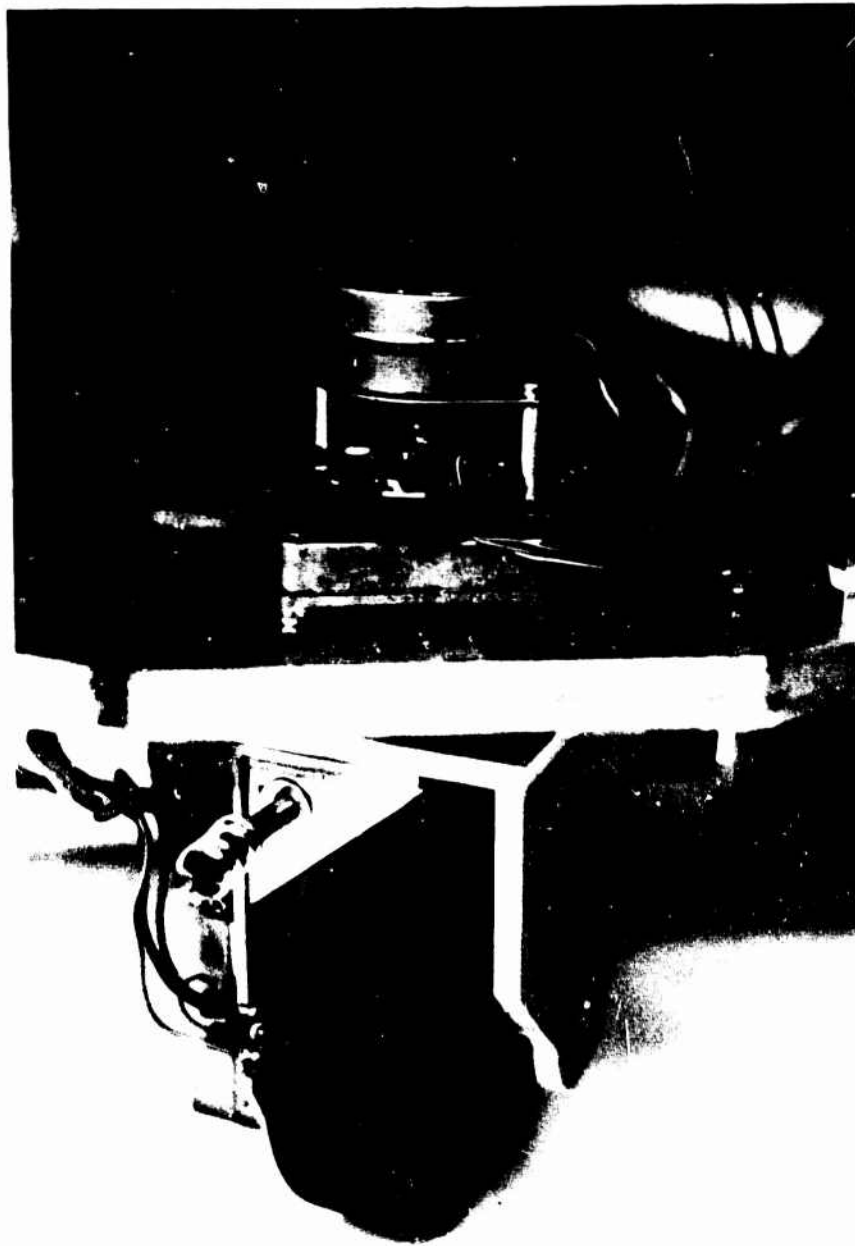

Figure 4.1 Modified Front Wheel Assembly

5. The MENOS-1 upgrade was then installed and tested. Proper operation of the original HERO-1 electronics and the new serial communication port was verified by connecting the robot to the lab H89 computer. The resulting combination of robot electronics was named the Drive Computer so as to distinguish it from the electronics yet to be added. The Input/Output (I/O) decoding scheme for the Drive Computer was extended (as shown in Appendix H) to allow further I/O expansion.

6. The Optical Shaft Encoder (OSE) Subsystem was built, installed and initially connected to the Drive Computer thru a 40 pin connector. In spite of extreme efforts to be careful, four glass encoder disks were cracked or broken while trying to install the OSEs (Appendix K) on the front wheel steering shaft (see figure 4.1) and the rear wheel shafts. The alignment of the OSEs took on the order of four hours for each encoder. What is needed is an encoder that that is sealed, prealigned, small, inexpensive, and connects to the shaft with a flexible linkage.

7. The Nav Computer was wirewrapped on an Augat prototyping board and hardware/software debugged using a Hewlett Packard 1610A logic analyzer. The OSE Subsystem was disconnected from the Drive Computer and connected instead to the Nav Computer with the Sonar Subsystem. The two subsystems conceptually can be used as a crosscheck against each other if a priori knowledge about an environment is

given and function optimally if the subsystems are connected to the same virtual computer.

8. The Sonar Subsystem was connected and debugged on the Nav Computer only after proper operation of the computer (CPU, ROM, RAM, and interrupt driven I/O devices) was verified.

Sideline Activities

Many side issues, projects, and activities consumed time during the thesis and in their own way contributed to the success of the effort. These included:

1. Participation in the 10th Annual Dayton International Air Show representing AFIT with the newly painted and rewired MARRS-1 robot.

2. Taking MARRS-1 to the National Explorer Scout Fly-In at Columbus, Ohio (once again to represent AFIT).

3. Television, radio, and newspaper interviews, along with presentations to public school groups, kept MARRS-1 (and its creators) busy informing the public about AFIT research.

4. The AFIT Mobile Robotics Laboratory was created during the thesis by scrounging for resources necessary to do this type of hardware/software development project. The physical space of the lab was absolutely essential for the success of the thesis. The floor of the test area had to be leveled by using wall plaster to fill in holes and depressions.

5. Two other computer systems were built during the thesis effort to support software and hardware development. A Motorola Exorciser and a 6802 based printer controller card (previously developed for an AFIT project) were the only 6800 family computers in the school. Both needed extensive modification and rehabilitation to meet the development needs of the thesis.

With the robot hardware and software development complete, a series of Robot Integrated Operation Tests (RIOTs) were conducted.

Robot Integrated Operation Test (RIOT) Plan

The RIOTs demonstrate the ability of MARRS-1 to keep track of its own location and map out the environment. The RIOTs also identify anomalies (if any) in robot and algorithm operation while they (the tests) manipulate data collected from both the OSE and Sonar subsystems into a form useful for robot obstacle avoidance, path planning, and robot performance benchmarking.

Test Range Environment

The test range used for the RIOTs is part of the AFIT Mobile Robotics Laboratory with dimensions of 13 feet by 25 feet. All doors to the test range remain closed during each test run. Test conditions are broken into two categories; tests without objects in the test range and tests with two objects in the test range (see figures 5.1 and 5.2).

Object number one is composed of a large 3' diameter 2' 7" high cylinder. Object number two is a box with the following dimensions: 1' 6.5" wide, 2' 9.5" long, 2' 3" high. Both objects have cardboard material surfaces. The test range floor is a reasonably flat tile surface. The walls of the test range are painted hardboard. Some minor protrusions such as door knobs, conduit, and molding jut out from the surface of the walls. All walls are assumed to be flat surfaces since the 0.1 foot sonar range resolution of cannot accurately distinguish these protrusions.

MARRS-1 Operating Modes

In order to collect enough data to form a map of the test range the robot is operated in an open loop mode and moved throughout the test range. Two patterns of movement will be tested; a straight line path and a zig-zag pattern. The initial test run location and heading of the robot should be kept the same (in this case X = 2 feet, Y = 7 feet) for ease of setup. Sight tubes, mounted on the robot, aide in the initial positioning of the robot. The upper level head of the robot is rotated 15 degrees clockwise to provide a 360 degree coverage from the 24 ultrasonics transducers with 15 degrees of separation between each transducer. Additionally, the number of sonar transducers selected during each cycle of the interrupt handler varied from test to test. Table 4.1 lists sixteen different test configurations that were used.

TEST #	OBJECTS	PATH	# SONARS	SELECTED PER PERIOD
4	TWO	STRAIGHT	2 PER	.1 sec
5	TWO	STRAIGHT	1 PER	.1 sec
7	TWO	STRAIGHT	3 PER	.1 sec
9	TWO	STRAIGHT	4 PER	.1 sec
10	TWO	ZIG ZAG	1 PER	.1 sec
11	TWO	ZIG ZAG	2 PER	.1 sec
12	TWO	ZIG ZAG	3 PER	.1 sec
13	TWO	ZIG ZAG	4 PER	.1 sec
14	NONE	ZIG ZAG	1 PER	.1 sec
15	NONE	ZIG ZAG	2 PER	.1 sec
16	NONE	ZIG ZAG	3 PER	.1 sec
17	NONE	ZIG ZAG	4 PER	.1 sec
18	NONE	STRAIGHT	1 PER	.1 sec
19	NONE	STRAIGHT	2 PER	.1 sec
20	NONE	STRAIGHT	3 PER	.1 sec
21	NONE	STRAIGHT	4 PER	.1 sec

Table 4.1 RIOT Configurations

Support Equipment

The following equipment provides the necessary support to conduct this test; the AFIT MARRS-1 robot, Heath H-89 computer with H-27 8 inch disk drive system, Modem 720 communication program, and an RS-232 cable. Post mission processing of the collected data is performed on a TRS-80 (6809 based) Color Computer.

Drive Computer Learn Mode Programs

The learn mode programs shown in tables 4.2 and 4.3 run in the Drive Computer and cause the MARRS-1 robot to perform either straight line motion or a zig-zag pattern within the confines of the test range. (For a more detailed discussion of robot interpreter commands the reader is referred to the Heathkit Educational Systems ET-18 ROBOT Technical Manual.)

ADDRESS	DATA	HERO-1 ROBOT LANGUAGE AND MEANING
0400	C3 19 6F	MOTOR MOVE, WAIT ;ABSCLUTE(IMMEDIATE) DRIVE MOTOR SELECTED FORWARD \$16F FAST GEAR
0403	8F 00 20	PAUSE (IMMEDIATE)
0406	3A	RETURN TO EXECUTIVE ("READY")

Table 4.2 MARRS-1 Straight Line Drive Computer Program

ADDRESS	DATA	HERC-1 ROBOT LANGUAGE AND MEANING
0400	C3 18 06	MOVE DRIVE MOTOR (HIGH SPEED) FORWARD \$06
0403	CC 18 15	MOVE DRIVE MOTOR (HIGH SPEED) FORWARD \$15
0406	C3 E8 33	TURN LEFT TO POSTION \$33
0409	CC 18 4E	MOVE DRIVE MOTOR (HIGH SPEED) FORWARD \$4E
040C	C3 E8 49	TURN STRAIGHT AHEAD
040F	CC 18 1C	MOVE DRIVE MOTOR (HIGH SPEED) FORWARD \$1C
0422	C3 E8 64	TURN RIGHT TO POSITION \$64
0425	CC 18 22	MOVE DRIVE MOTOR (HIGH SPEED) FORWARD \$22
0428	C3 E8 49	TURN STRAIGHT AHEAD
042B	CC 18 12	MOVE DRIVE MOTOR (HIGH SPEED) FORWARD \$12
042E	C3 E8 57	TURN RIGHT TO POSITION \$57
0431	CC 18 0C	MOVE DRIVE MOTOR (HIGH SPEED) FORWARD \$0C
0434	C3 E8 49	TURN STRAIGHT AHEAD
0437	CC 18 0D	MOVE DRIVE MOTOR (HIGH SPEED) FORWARD \$0D
043A	C3 E8 58	TURN RIGHT TO POSITION \$58
043D	CC 18 39	MOVE DRIVE MOTOR (HIGH SPEED) FORWARD \$39
0440	C3 E8 49	TURN STRAIGHT AHEAD
0443	CC 18 17	MOVE DRIVE MOTOR (HIGH SPEED) FORWARD \$17
0449	C3 E8 31	TURN LEFT TO POSTION \$31
044C	CC 18 18	MOVE DRIVE MOTOR (HIGH SPEED) FORWARD \$18
044F	C3 E8 46	TURN RIGHT TO POSITION \$46
0452	CC 18 00	MOVE DRIVE MOTOR (HIGH SPEED) FORWARD \$00
0455	C3 E8 42	TURN LEFT TO POSTION \$42
0458	CC 18 25	MOVE DRIVE MOTOR (HIGH SPEED) FORWARD \$25
045B	C3 E8 49	TURN STRAIGHT AHEAD
045E	8F 00 FF	PAUSE
0461	3A	RETURN TO EXECUTIVE ("READY")

Table 4.3 MARRS-1 Zig-Zag Drive Computer Program

Robot Test Procedures

1. Objects (if any) are placed in the test range with their location and orientation documented.

2. Document and mark on the floor the initial heading and position of the robot. Heading is normalized for the program MAPPER (Appendix C) as a value between 0 and 1 as shown in figure 4.2. The (X,Y) location of the robot is represented in terms of tenth's of feet (resolution of 1.2"). The initial location and all subsequent locations of the robot are relative to the mid point between the two rear wheels. Both heading and location are crucial in conducting this test with any accuracy/repeatability and are required for post mission processing of the Sonar and OSE data.

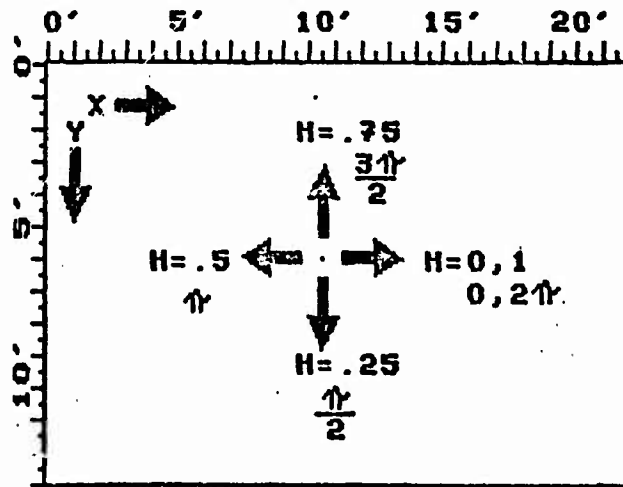

Figure 4.2 MAPPER Heading Convention

3. Straighten out the front wheel and insure that the count at memory location \$0026 of the Drive Computer contains the value \$49. (\$49 is the value for straight forward steering.)

4. Insure that the top deck is rotated clockwise (looking down on robot) by 15 degrees and secured in place.

5. Put MARRS-1 in the learn mode and maneuver it throughout the test range. NOTE: The Drive Computer will operate the robot in an open loop mode for the entire test, i.e. there will be no feedback from the Nav Computer to the Drive Computer as a result of MARRS-1's movements or the environment.

6. After completion of the learn mode, reset the Drive Computer and bring MARRS-1 back to the marked starting position. Insure that the front wheel is straight and location \$0026 contains \$49. With all of this completed, execute the learned program to confirm that the robot performs adequately. If so, continue. If the robot fails to repeat the learned operation, then go back to step 2 and begin over again.

7. As in step 6, position the robot at the starting point. Now, upload the learned Drive Computer program to an external computer via the serial RS-232 port and save.

8. Before executing the test program, open a file buffer on an external computer connected to the Nav computer.

9. Reset the timer on Navigation Computer to zero.

10. Initialize the Extended Interrupt Handler to select the number of sonars activated per sample period (i.e. one, two, three, or four sonars selected during 1/10th of a second interval) and execute the Drive Computer's learned test program (Table 4.2 or 4.3).

11. After each test run, insure that the captured test data is saved on magnetic media in ASCII format before continuing on with the next test run.

Data Collection

Data from each of the subsystems will be gathered every 0.1second via the Extended Interrupt Handler (see Appendix B) and stored into a temporary line buffer in the Navigation Computer's memory as follows:

```
/time/fw/lw1/lw2/rw1/rw2/A#____/B#____/C#____/D#____/<CR><LF>
```

Where time = tenth's of seconds count - 2 bytes

fw = front wheel direction - 1 byte

lw1 = left wheel reverse counts - 2 bytes

lw2 = left wheel forward counts - 2 bytes

rw1 = right wheel reverse counts - 2 bytes

rw2 = right wheel forward counts - 2 bytes

Table 4.4 RIOT Raw Data Format

The buffer is then transmitted to an external computer at 9600 baud (in this case an H-89 running M720 communication software). Buffer contents are then stored onto magnetic media for post mission processing.

Test Data Usage

After completion of the entire test all data is then transferred from the H-89 to the Color Computer. Using MAPPER, a mapping algorithm, (see Appendix C) the test data will be transformed into a bit plane graphics representation of the test range. Optical shaft encoder readings determine position and heading of the robot relative to the starting position (calculated with respect to the center between the rear wheels). Sonar transducer readings provide range and direction information about the robots environment from the current robot position (with respect to the center of the robot). This graphics display provides a good first order approximation of the robots environment.

V. MARRS-1 Integrated Operation Test Results

Minor Test Problems

Three minor problems occurred during the MARRS-1 Robot Integrated Operation Tests (RIOTs). However, these three anomalies did not remove the essence of the tests. They are minor and can be overcome. First, the front wheel optical shaft encoder resolution was much greater than was required. The slightest hint of mechanical vibration caused excessive jitter in the signal detected by the photo head assembly. This resulted in erroneous accumulation of counts for front wheel direction. Fortunately MARRS-1 was operated in an open loop mode. The mapping algorithm, MAPPER did not require the data from the front wheel shaft encoder. An example of these erroneous readings can be seen in Appendix O.

The second problem was with the right wheel optical shaft encoder. In spite of efforts to align the glass encoder disk, some reverse direction counts were detected while going forward. This error was of no consequence since all test runs were designed for forward motion of the robot and the MAPPER program disregarded the reverse counts from the left and right wheels. However, Navigation algorithms in general should take into account any reverse counts of either the left or right wheels. For instance, a very tight turn may cause the wheel on the inside of the turn to move

in the reverse direction. The slightly eccentric alignment of the right wheel optical shaft encoder causes erroneous reverse direction counts which may require the construction and installation of a new shaft.

The third minor setback to the completion and final testing of MARRS-1 was the inadequate current capabilities of the sonar power supply. The current surge requirements of more than one sonar transducer activated at once increased the effective internal impedance of the batteries. This reduced the output voltage applied to the sonar range boards (as well as all other subsystems) and hence maximum sonar detection range was reduced to 3.5 feet. An AC to DC power supply was employed to provide additional current drive for the sonar subsystem thus extending the maximum reliable sonar detection range to 7.5 feet.

Mapping Algorithm

The program MAPPER (see Appendix C) takes large amounts of test data and compacts it into an array of 256 by 192 picture elements (pixels) that can be displayed as a map for humans and/or used by a computer for robot control. If the heading of the robot is known at some initial starting point, then all other robot headings can be determined from the counts of the left and right optical shaft encoders. Instantaneous heading calculations may be performed if the initial heading and distances traveled by

each rear wheel are known. The following equation describes this principle (20:163):

$$HB = HA + (L - R)/D \quad \text{rad} \quad (5.1)$$

Where HB is the current heading of the robot in radians, HA is some initial heading in radians, L and R are absolute distances traversed by each wheel starting from the initial heading position, and D is the distance between the left wheel and the right wheel. It is interesting to point out however, that the initial heading is not absolutely required since all successive heading computations are relative to the first and so on. Naturally with a digital device, a continuous sampling is impossible. Thus the traversed distance of each wheel is broken up into incremental segments. The K-3 shaft encoder has a resolution of 1200 counts per revolution. MARRS-1's rear wheel circumference is equal to 18.75". The units used in the test were inches, thus it turned out that 64 counts on the shaft encoder equalled one inch of travel by the wheel exactly. The effective resolution of the wheels now becomes 18.75 counts per revolution. Just how much resolution do the robot's wheels need for navigation and environmental mapping? These test results show that fine detailed resolution may not be required. However, optimum wheel count resolution has not been considered here and is left as an area for further investigation.

Graphics Plots

The plots shown on the next several pages are the final output from MAPPER. There are perhaps several ways of displaying the data collected from each test run. Figure 5.1 shows a layout of the size of the test range in units of feet. It was in this benign environment that half of the test runs were conducted. Figure 5.2 identifies the location of the two objects used during the other half. As a comparison, figures 5.3 and 5.4 are taken from Lt Owen's thesis and show how he accomplished mapping from a HERO-1(2:VII-6,VII-7). A key point about Owen's work is that precise heading and position information was not available for displaying the relative position of sonar readings. The remaining graphic plots (figures 5.5 thru 5.20) are of the Robot Integrated Operation Tests (RIOTs) and demonstrate that a robot can create a low resolution map of its environment (relative to itself) using ultrasonic sonar as a "vision" device while keeping track of its orientation and location from wheel counts. Each sonar reading is displayed as an arc of 20 degrees at the distance measured from the center of the robot and plotted based on position and heading information determined from rear wheel optical shaft encoder data. The tests are termed integrated since robot performance is evaluated based on all systems working in concert.

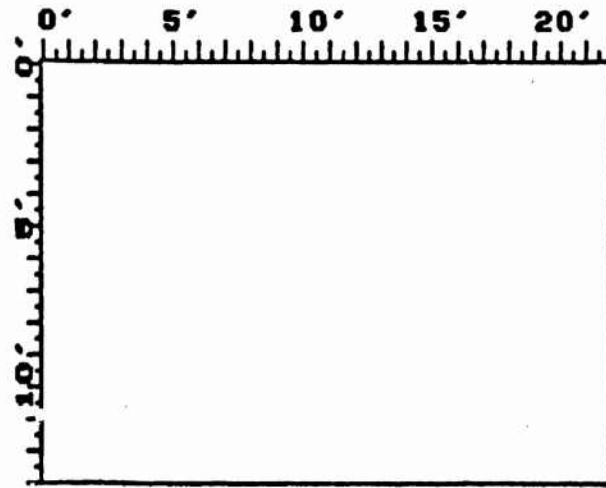

Figure 5.1 Robot Integrated Operation Test (RIOT) Range Layout

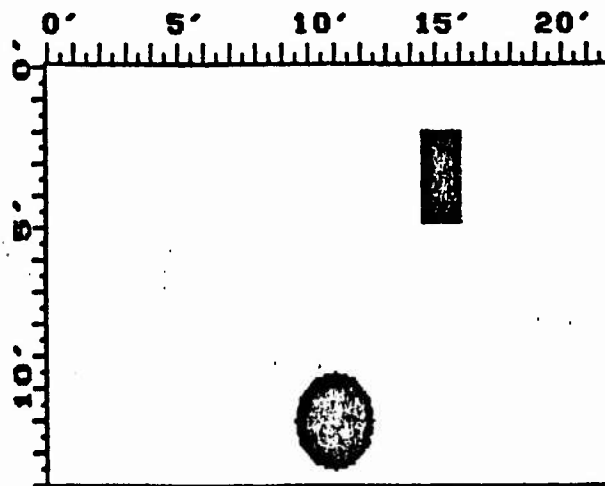

Figure 5.2 Location of Objects for RIOTs with Objects

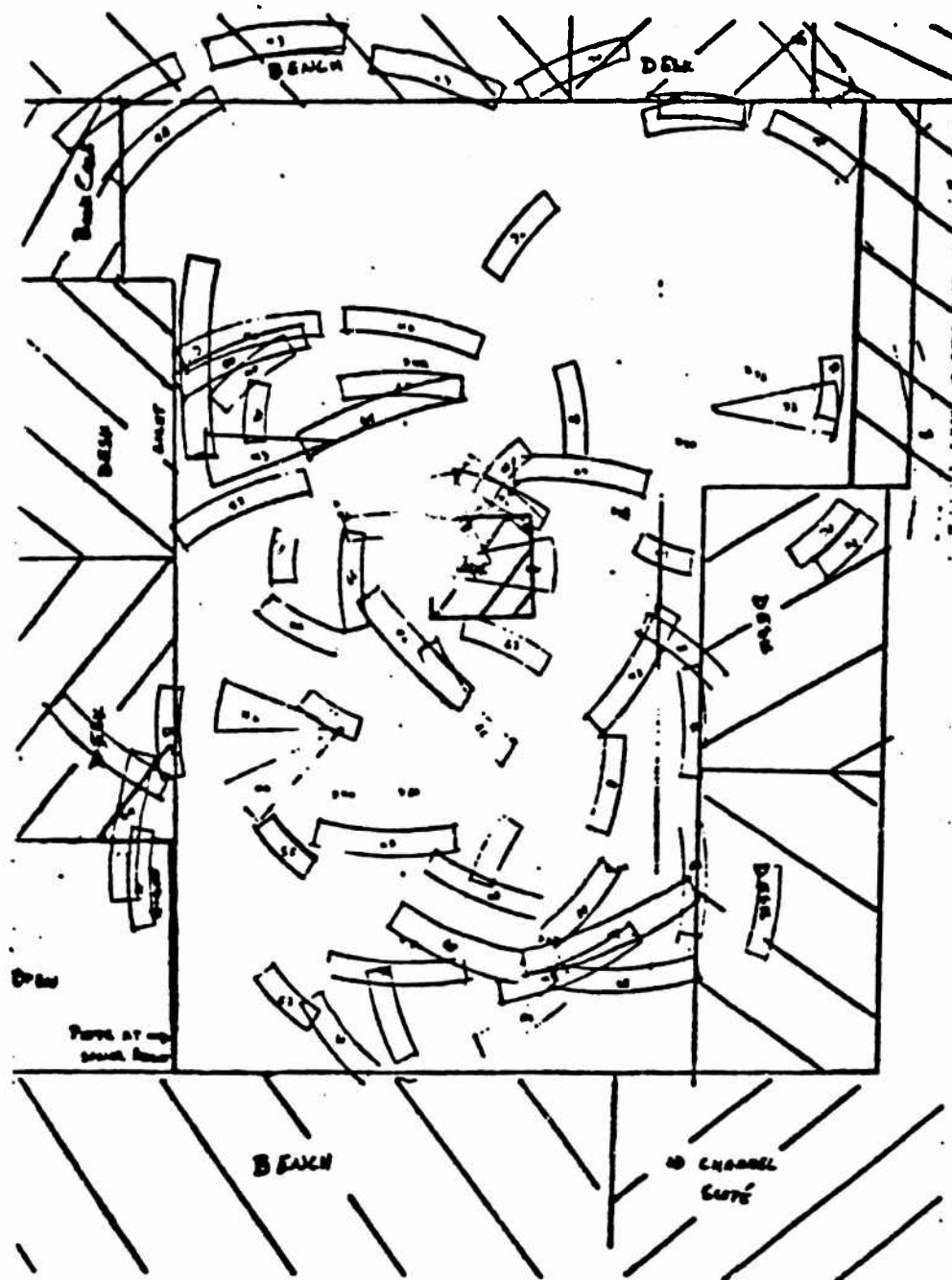

Figure 5.3 Owen Thesis Test Range Layout and Sonar Map

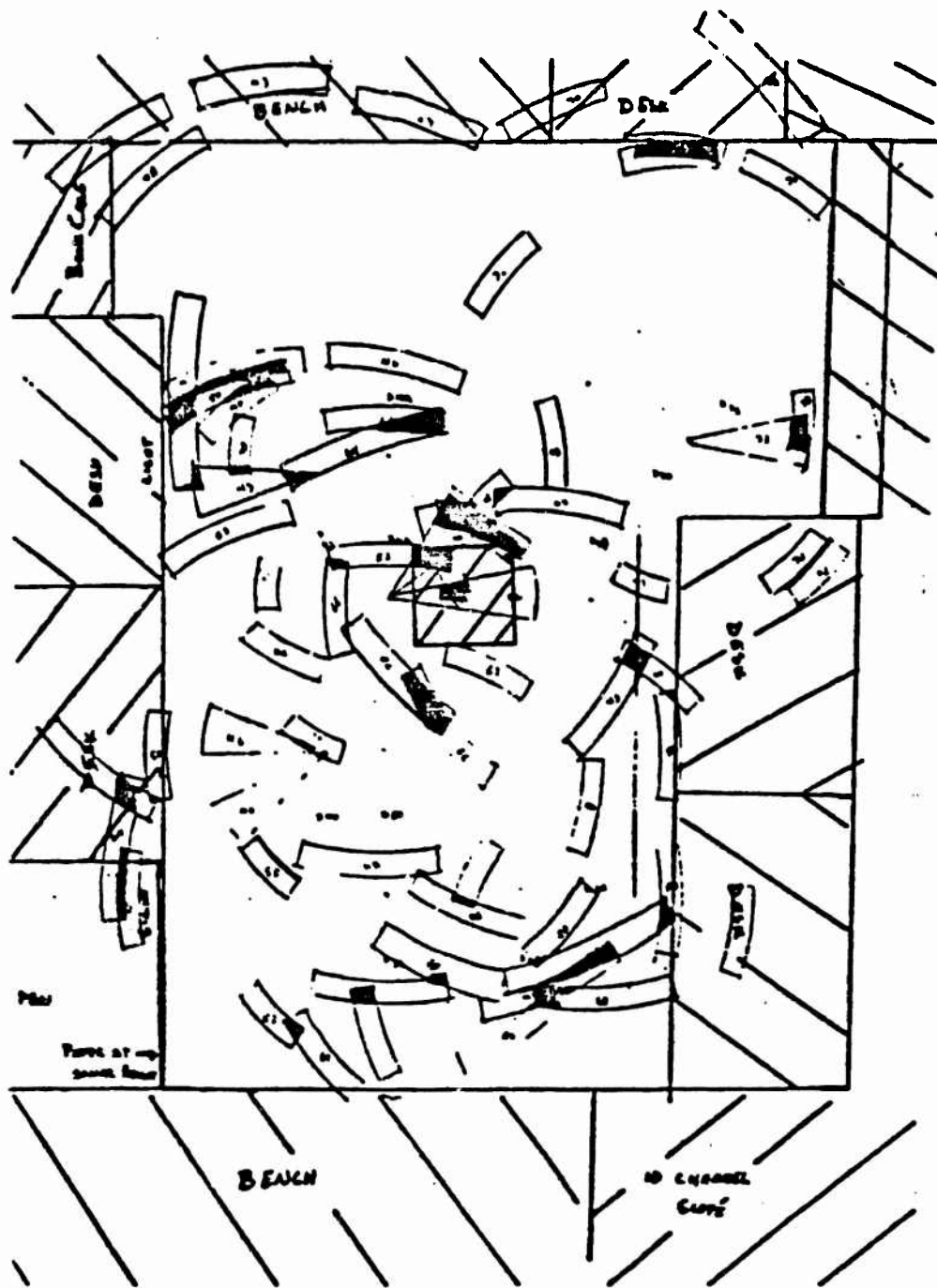
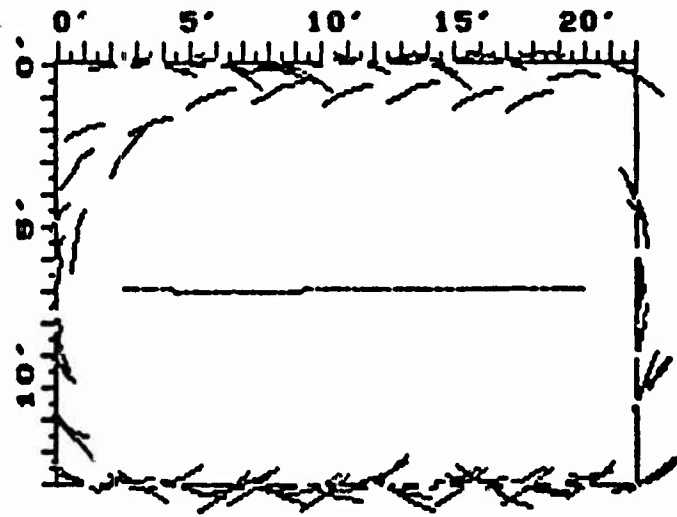

Figure 5.4 Owen Thesis Sonar Map Showing Sonar Coincidence.



1 SONAR/ 0.1 SEC TEST # 18

Figure 5.5 RIOT #18: Straight One Sonar at a Time

6

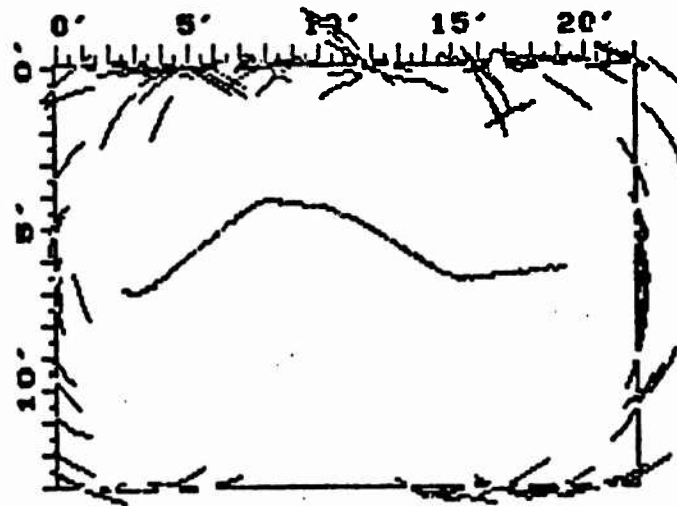

1 SONAR/ 0.1 SEC TEST # 14

Figure 5.6 RIOT #14: Zig Zag One Sonar at a Time

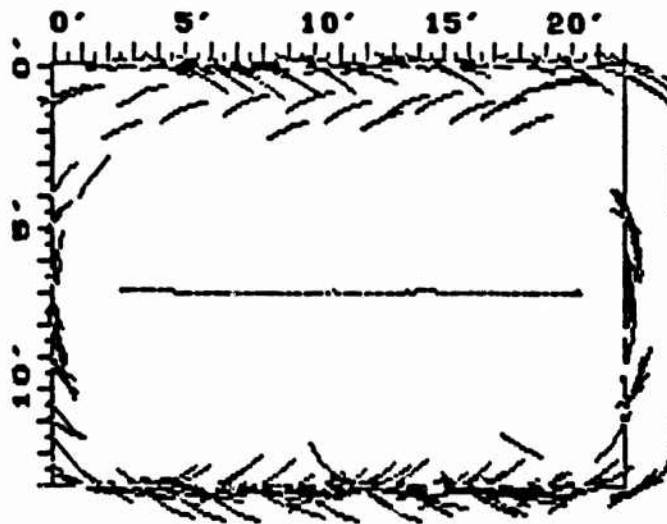

2 SONARS/ 0.1 SEC TEST # 19

Figure 5.7 RIOT #19: Straight Two Sonars at a Time

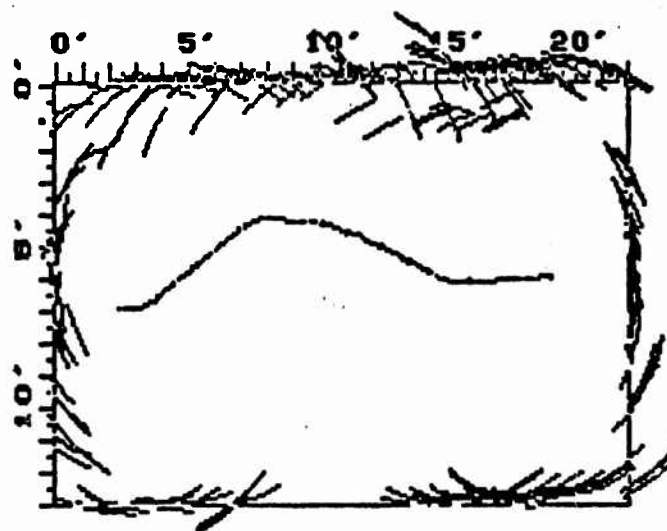

2 SONARS/ 0.1 SEC TEST # 15

Figure 5.8 RIOT #15: Zig Zag Two Sonars at a Time

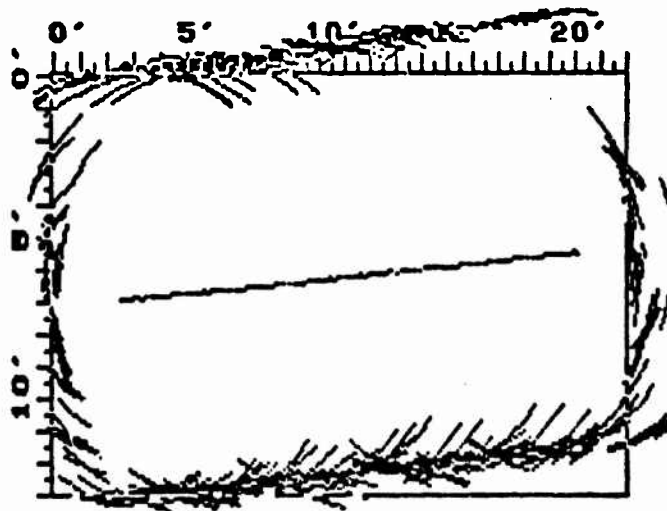

3 SONARS/ 0.1 SEC TEST # 20

Figure 5.9 RIOT #20: Straight Three Sonars at a Time

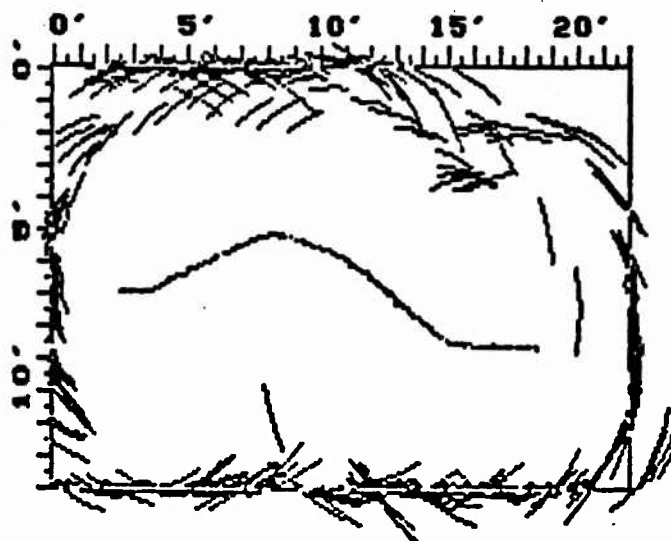

3 SONARS/ 0.1 SEC TEST # 16

Figure 5.10 RIOT #16: Zig Zag Three Sonars at a Time

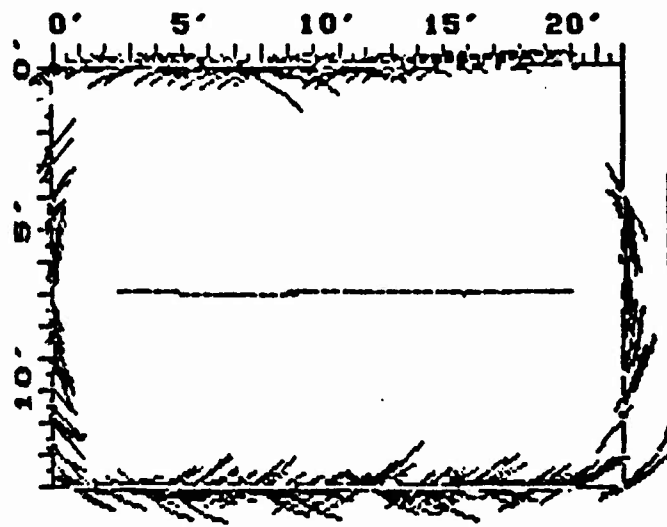

4 SONARS/ 0.1 SEC TEST # 21

Figure 5.11 RIOT #21: Straight Four Sonars at a Time

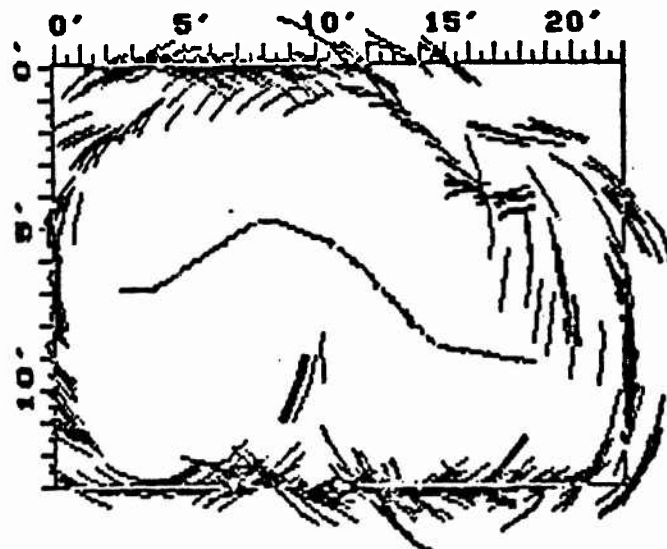

4 SONARS/ 0.1 SEC TEST # 17

Figure 5.12 RIOT #17: Zig Zag Four Sonars at a Time

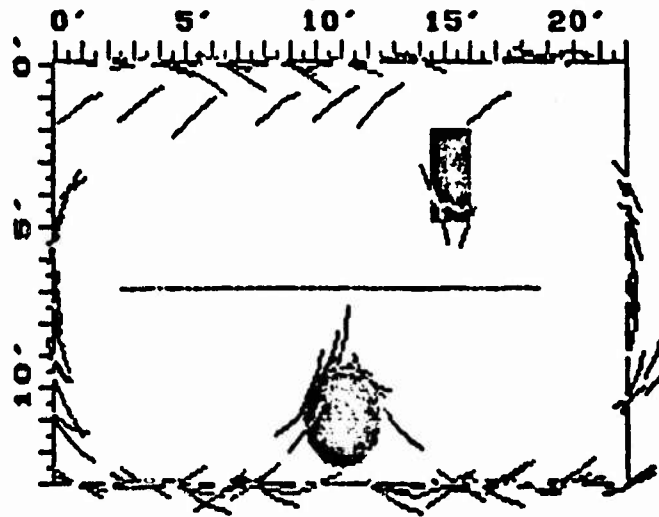

1 SONAR/ 0.1 SEC TEST # 5

Figure 5.13 RIOT #5: Straight One Sonar at a Time

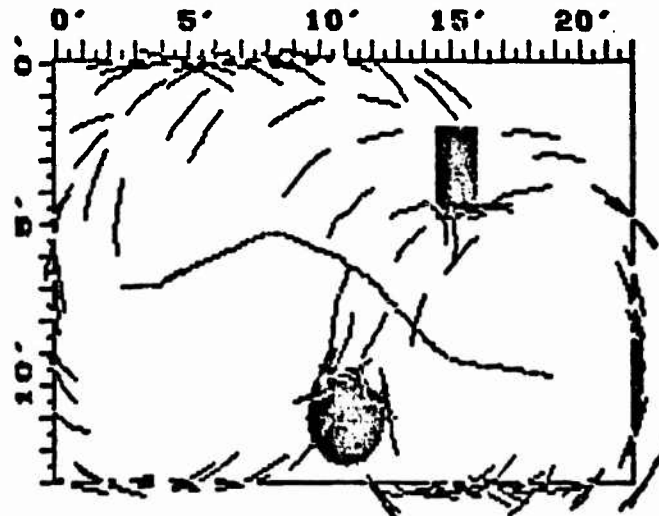

1 SONAR/ 0.1 SEC TEST # 10

Figure 5.14 RIOT #10: Zig Zag One Sonar at a Time

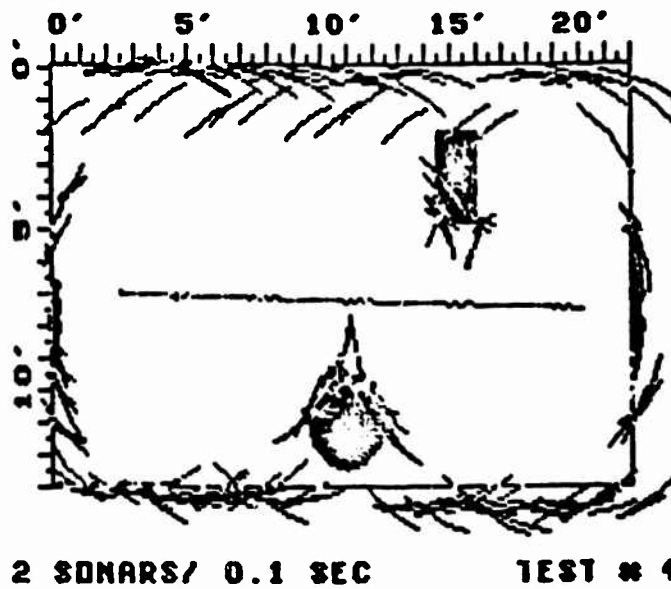

Figure 5.15 RIOT #4: Straight Two Sonars at a Time

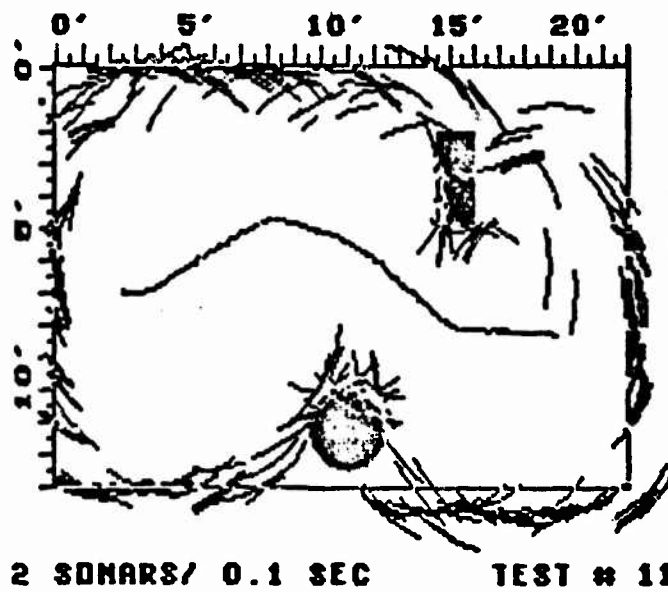
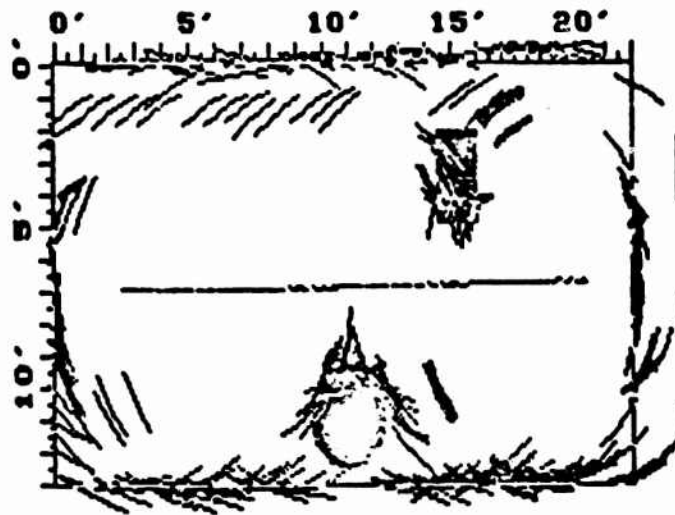
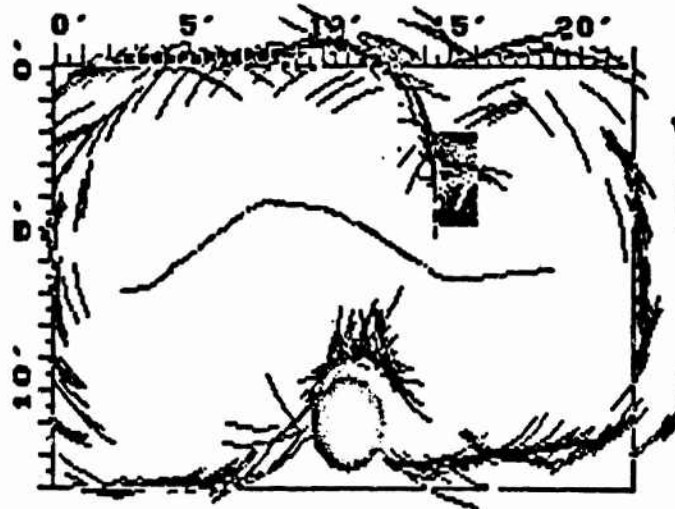

Figure 5.16 RIOT #11: Zig Zag Two Sonars at a Time



3 SONARS/ 0.1 SEC TEST # 7

Figure 5.17 RIOT #7: Straight Three Sonars at a Time



3 SONARS/ 0.1 SEC TEST # 12

Figure 5.18 RIOT #12: Zig Zag Three Sonars at a Time

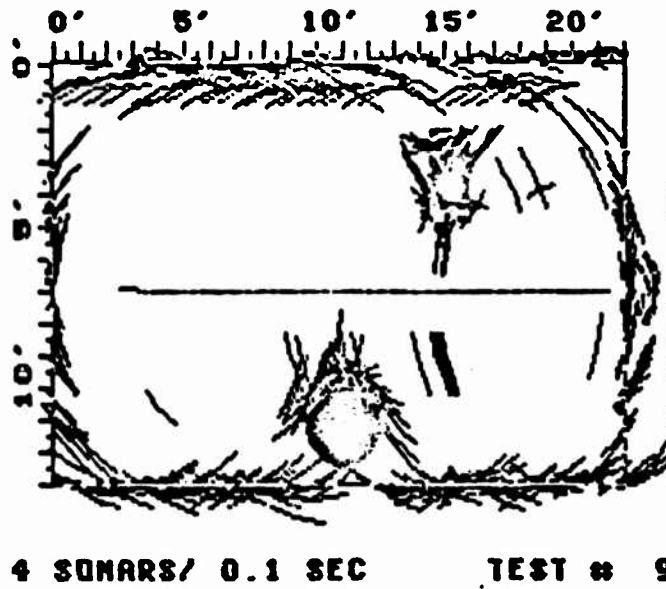

Figure 5.19 RIOT #9: Straight Four Sonars at a Time

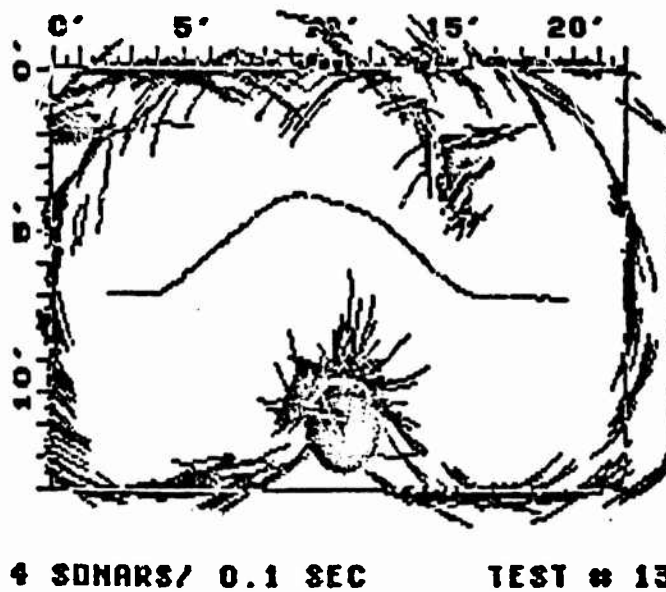

Figure 5.20 RIOT #13: Zig Zag Four Sonars at a Time

Discussion of RIOT Results

Each plot from figures 5.5 thru 5.20 represents 14 to 20 thousand eight bit words (bytes) of data like that shown in Appendix O. The data could have been encoded by the Extended Interrupt Handler (Appendix B) and reduced by a factor of four to one, however, the data reduction would have cost increased processing time by the MAPPER program of Appendix C.

Figures 5.5 thru 5.20 are accurate sonar environmental maps as compared to those of figures 5.3 and 5.4 because of the accurate heading and position information coming from the shaft encoders.

The new sonar maps show that robot navigation and obstacle avoidance in simple environments are possible from low resolution sonar vision with accurate position information.

Particular attention should be given to figure 5.9. This map identifies a skew of the sonar map with respect to the test range outline. The skew was a result of having an initial one and a half inches of right wheel travel recorded in the data (see start of Appendix O) when in fact the right wheel travel distance should have tracked the values recorded for the left wheel for straight motion (which was the case for all other straight line motion RIOTs). The difference between the right and left wheel counts was a result of having not reset the Navigation Computer after

preparing the robot for RIOT #20. The skew of figure 5.9 is therefore the result of robot operator error. It does, however, show the effect of initial heading error or isolated wheel slippage with respect to an external benchmark reference system. Note that the sonar map can be accurately created without an external reference since the map is always relative to the robot's own internal heading and position. Therefore, the map created by the robot may require a coordinate transformation to a global or external reference.

Sonar ranges greater than 7.5 feet were disregarded for all RIOT plots since the power supply problem attenuated the maximum reliable detection for the Sonar Subsystem. Additionally, stray sonar readings are seen in a few plots. Sonar transducer C2 (figure 3.4) appears to have a maximum reliable detection range of about 7 feet and hence, the stray readings from C2 were not deleted with the 7.5 foot filter algorithm in the MAPPER program.

VI. Recommendations for Future Work on MARRS-1

Unlike some products on the market today, MARRS-1 was designed and built with modularity and expansion in mind. In addition, there are a few minor flaws in the original design that can be improved. The following are just some of the recommendations and suggestions for additional work and enhancements that will some day make MARRS-1 a truly autonomous vehicle.

1. Exercise the existing MARRS-1 robot to identify the limit of its usefulness and capabilities.
2. Transport the mapping algorithm MAPPER from an external computer to an onboard computer (either as part of the Navigation Computer interrupt handler or on another computer which communicates to the Navigation Computer via RS-232).
3. Design, develop, and interface an on board compass (perhaps using an A to D converter or absolute encoder) to provide MARRS-1 with instantaneous heading information. This sensor data could be used as an additional check to verify data coming from other subsystems and provide initial heading data on power-up.
4. Develop filtering algorithms that provide MARRS-1 with more accurate maps of its environment. Perhaps further characterization of the sensor subsystems is required before this can be accomplished.

5. The entire front wheel assembly requires a re-design effort. The combined mass of the yoke and the drive motor puts too much of a strain on the small gear box and shaft encoder disk mounted above. A larger frame gear box with a similar gear reduction ratio is required to eliminate false readings from the shaft encoder.

6. The MARRS-1 steering shaft feedback uses a high resolution incremental encoder to do a low resolution absolute encoder's job. A low resolution absolute encoder connected to the steering shaft by a flexible link will provide accurate information about the direction of the front wheel without excessive software/hardware overhead.

7. A better power supply for the sonar subsystem is required.

8. Integrate the electronics developed for the MARRS-1 robot structure on a larger heavier frame: a fork lift, a golf cart, or perhaps a rugged all-terrain vehicle used by the U.S. ARMY or coal mine companies.

9. Integrate Captain Glenn Monaghan's robot task planning thesis (AFIT/ENG/84D-47) with the MARRS-1.

10. Investigate the advantages/disadvantages of three wheel, four wheel, and tracked mobility configurations along with different drive and steering control systems as they apply to the mobile autonomous robot problem.

Yet Another Computer for MARRS-1

The next logical progression of MARRS-1 is to provide another computer which will control the functions of all subordinate computer systems. Its function would be much like that of a computer operating system only it would perform path planning based on sensory information fed to it from its subordinate systems and from requirements passed to it by an external computer data link. An onboard MC6809 based Radio Shack Color Computer would be the perfect addition to the droid ensemble. By adding a disk controller and disk drives, the robot becomes a stand alone hardware/software development device (minus a keyboard and monitor which may be connected remotely, or as needed).

There are several reasons for choosing the MC6809 or MC6809E over other microprocessors. First, all hardware and software developed thus far for MARRS-1 is upward compatible with the 6809. Second, with the use of OS-9 (a UNIX derivative) as the operating system, the computer can perform multi-tasking and supervise a multi-user environment. These characteristics are ideal for control of a mobile autonomous robot. Third, hardware/software availability is perhaps the most important issue as discussed in chapter II. The AFIT Mobile Robotics Lab has in its inventory (see Appendix J) a Color Computer with OS-9 and BASIC09. The Motorola Exorciser can also accommodate a 6809 card to enhance lab capabilities.

High level languages such as C open the door to increased routines and utilities that can be used to control MARRS-1. "Fortunately, the 6809 microprocessor, the OS-9 operating system, and the C language form an outstanding combination. The 6809 was specifically designed to efficiently run high level languages, and its stack-oriented instruction set and versatile repertoire of addressing modes handle the C language very well. As mentioned previously, UNIX and C are closely related, and because OS-9 is derived from UNIX, it also supports C to the degree that almost any application written in C can be transported from a UNIX system to an OS-9 system, recompiled, and correctly executed"(21:1-1). Migration toward the 68000 family is also possible by first going to the 6809 and OS-9. There is even a version of OS-9 for the 68000 family of processors making a simplified software transition guaranteed.

Cooperation Needed in Mobile Robotics

Mobile Robotics has the responsibility of bringing many technologies and disciplines together as a unified whole and has two closely related areas of research: 1) Artificial Intelligence (AI), and 2) Pattern Recognition (PR). In their report to the U.S. Army Engineer Topographic Laboratory, researchers from Stanford Research Institute (SRI) made no distinction between AI and Robotics giving instead a unified model of the two as shown in figure 6.1 (22:1).

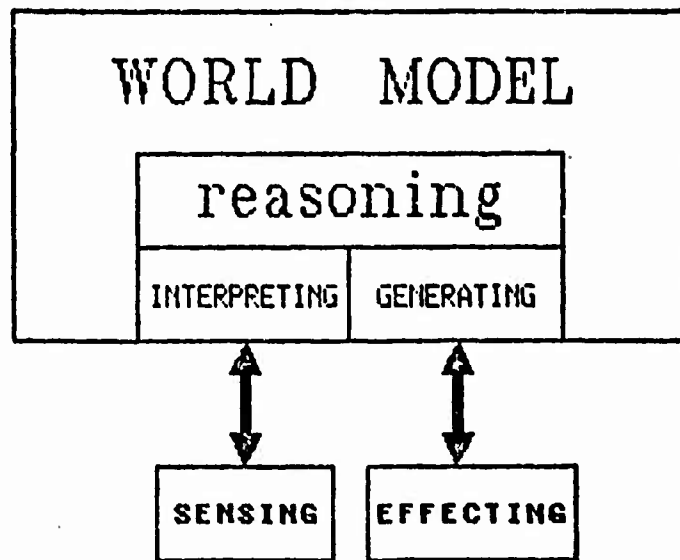

Figure 6.1 Unified AI/Robotics Model

The part of Pattern Recognition (PR) that deals with the gathering and interpreting of sensory information falls in the area of figure 6.1 labeled SENSING<--->INTERPRETING. The AFIT MARRS-1 robot in conjunction with the stereo vision system being developed by Captain James Holten of the AFIT Signal Processing lab could form the hardware of the SENSING<--->INTERPRETING and GENERATING<--->EFFECTING blocks of figure 1. Pattern Recognition would provide software for these same blocks while software for the REASONING and WORLD MODEL blocks would be provided by Artificial Intelligence. Additional sensor systems, communications, computers, software, and hardware are required to make MARRS-1 a truly autonomous robot. However, the required resources do exist within the AFIT Electrical Engineering

Department. It may be argued that it is impossible to build a truly autonomous robot since all machines created by mankind have limitations. Yet, if allowed only to use existing technology, a mobile robot with tremendous capabilities could still be realized. What is needed is a commitment from the highest level possible to solve the autonomous robot problem. The MARRS-1 robot is only a start towards that solution.

Intradepartment and interdepartment cooperation to solve problems would benefit all involved. Dr. Hans Moravec, creator of the Stanford Cart and the Carnegie-Mellon University (CMU) Rover, argues that advances in mobile robotics would bring more robust and general AI tools (23:1), (24:882). Would that not be true for all disciplines that cooperated?

Conclusion

Robots need sensors along with their mechanical devices and computational elements to be effective. This places a new perspective on the responsibilities of mobile robot designers and programmers in the way that they attack and solve their problems. These are system integration problems with demanding requirements. Overlooking an item that seems trivial may have long range negative consequences. To be sure, all that is important in mobile robotics has not been identified in this thesis.

Bibliography

1. Taylor, Captain Roslyn J. An Android Research and Development Program, MS Thesis AFIT/GE/EE/83M-3. School of Engineering, Air Force Institute of Technology (AU), Wright-Patterson AFB OH, March 1983 (AD-A127 359).
2. Owen, 1Lt Randall J. III. Environmental Mapping by a Hero-1 Robot Using Sonar and a Laser Barcode Scanner, MS thesis, AFIT/GE/EE/83D-52. School of Engineering, Air Force Institute of Technology (AU), Wright-Patterson AFB OH, December 1983 (AD-A138 348).
3. Craig, John. "Digital Speed Control of DC Motors," in the Beginning, New Jersey: Hayden Book Co, 1983.
4. Iijima, J, and others; "Elementary Functions of a Self-contained Robot 'Yamabico 3.1'," Proceedings of the 11th International Symposium on Industrial Robots; 7, 8, and 9 Oct, 1981.
5. Starns, Thomas W. "Design Philosophy Behind Motorola's MC68000 Part 1," Byte, 8-4: 70-91 (April 1983).

6. Starns, Thomas W. "Design Philosophy Behind Motorola's MC68000 Part 2," Byte, 8-5: 342-367 (May 1983).
7. Starns, Thomas W. "Design Philosophy Behind Motorola's MC68000 Part 3," Byte, 8-6: 339-349 (June 1983).
8. ICAM Robotics Application Guide (RAG), Air Force Wright Aeronautical Laboratories, Materials Laboratory, AFWAL TR-80-4042-VOL-2, Wright-Patterson AFB, OH, 1980 (AD-B050 811).
9. Robillard, Mark J. Microprocessor Based Robotics, Indiana. Howard W. Sams & Co., Inc., 1983.
10. Lemaire, B., and others. "A Self Adapting Low Cost Sonair for Use on Mobile Robots," Sensor Review, Oct, 1981.
11. McKean, Kevin "Computers that See," Discovery, 7:72-73, September 1984.
12. Jarvis, R. A. "A Perspective on Range Finding Techniques for Computer Vision," IEEE Transactions on Pattern Analysis and Machine Intelligence, 5:122-139 (March 1983).

13. Keller, Erik L. "Clever Robots Set to Enter Industry En Masse," Electronics, 56: 116-129 (November 17, 1983).
14. Iverson, Wesley R. "Low Cost Eyes Judge Distance," Electronics, 56: 54,56 (November 17, 1983).
15. Polaroid, Ultrasonic Ranging System, Undated.
16. Jarvis R. A. "A Laser Time-of-Flight Range Scanner for Robotic Vision," IEEE Transactions on Pattern Analysis and Machine Intelligence, 5: 505-512 (September 1983).
17. Crowley, James L. A Computational Paradigm for Three Dimensional Scene Analysis, The Robotics Institute, Carnegie-Mellon University, Pittsburgh, PA, April 1984.
18. Crowley, James L. Navigation for an Intelligent Mobile Robot, The Robotics Institute, Carnegie-Mellon University, Pittsburgh, PA, March 1984.
19. Webster's Seventh New Collegiate Dictionary, Springfield, Mass: G. & C. Merriam Co., 1972.
20. Fujiwara, N. and Tsumura, T. "An Experimental System For Processing Movement Information of Vehicle," 28th IEEE Vehicular Technology Conference Proceedings, Denver, CO, 163-168, March 1978.

21. MICROWARE C COMPILER USER'S GUIDE, Radio Shack, a Division of Tandy Corporation, 1983.

22. Brown, David R.; Fowler, Darrell V.; et al; R&D Plan for Army Applications of AI/Robotics; ETL-0296, U.S. Army Engineer Topographic Laboratories, Fort Belvoir, Virginia, May 1982, (AD-A118 297).

23. Elfes, Alberto; Talukdar, Sarosh N. A Distributed Control System for the CMU Rover, The Robotics Institute, Carnegie-Mellon University, Pittsburgh, PA, January 1983.

24. Moravec, Hans P. "The Stanford Cart and the CMU Rover," Proceedings of the IEEE, 71: 872-884 (July 1983).

Vita

First Lieutenant Thomas E. Clifford was born [REDACTED] [REDACTED] in [REDACTED] [REDACTED] [REDACTED] where, in 1968, he graduated from [REDACTED] [REDACTED] and enlistmented in the Utah Air National Guard.

He enlisted in the Regular Air Force in 1973 and became an honor graduate of the B-52 Bomb-Navigation maintenance school at Lowry AFB, Colorado. He was assigned to the 92 Bomb Wing at Fairchild AFB, Washington in 1974 and was President of the Wing Enlisted Advisory Council in 1976. In 1977 he was assigned as an IBM computer operator at the 1035th Technical Operations Group, Patrick AFB, Florida.

He received an Associate degree from the Community College of the Air Force in 1978, and a Bachelor of Science degree in Electrical Engineering from Texas Tech University in 1980 under the Airman Education and Commissioning Program. He was commissioned a Reserve Second Lieutenant in December of 1980 from Officer Training School and assigned to the 3246th Test Wing, Eglin AFB, Florida as an Electronic Warfare Test Engineer.

Lieutenant Clifford is the 1982 recipient of the Air Force Systems Command's General James Ferguson Engineering Award. He entered the Air Force Institute of Technology in May 1983 and was selected for Regular Commission status in June 1984.

Lieutenant Clifford is married to the former [REDACTED] [REDACTED] of [REDACTED] [REDACTED] [REDACTED] [REDACTED]. They have five children: [REDACTED] [REDACTED] [REDACTED] [REDACTED] [REDACTED] i.

Address: [REDACTED]
[REDACTED] [REDACTED] [REDACTED]

Vita

CAPTAIN HUBERT G. SCHNEIDER III

Captain Schneider was born [REDACTED]
Upon graduation in 1976 from [REDACTED] [REDACTED] in
[REDACTED] [REDACTED] he matriculated as a cadet at the
Virginia Military Institute, where in 1980 he completed the
requirements for a B.S. in Electrical Engineering and was
commissioned a Reserve Second Lieutenant of the United
States Air Force.

He was then assigned as Chief, Minuteman Survival Power
at the Ballistic Missile Office at Norton AFB, California
where he managed the production and deployment of a new
generation of high energy lithium batteries as part of the
Minuteman Extended Survival Power Program.

In 1983 he entered the Masters program at the Air Force
Institute of Technology, Wright Patterson AFB, Ohio and
received a Regular Commission while attending the school.

He is married to [REDACTED] [REDACTED] and they have one
daughter, [REDACTED]

Address: [REDACTED]
[REDACTED] [REDACTED] [REDACTED]

*
* APPENDIX A *
*

FILE: NAVROM.A MINUS NAVDEF.A
WHICH IS LISTED IN APPENDIX D

NOTE: PORTIONS OF THIS LISTING DO NOT HAVE COMMENTS.
MOTOROLA ENGINEERING NOTE 100 IS A COMPLETE LISTING FOR MIKBUG.
AMERICAN MICROSYSTEMS AMI 6800 PROTOTYPING BOARD MANUAL CONTAINS
A COMPLETE SOURCE CODE LISTING FOR THE PROTO PORTION OF THE CODE.

NAV COMPUTER ROM AS OF MONDAY 15 OCTOBER 1984 2:30 PM

get navhead.a

VERSION 1.0 OF MARRSBUG

LT TOM CLIFFORD, CAPT BERT SCHNEIDER

MARRSBUG IS A ROM BASED OPERATING SYSTEM FOR THE AFIT

MOBILE AUTONOMOUS ROBOT RESEARCH SYSTEM I (MARRS-1).

THE ROM CONTAINS A SERIAL VERSION OF THE MOTOROLA MIKBUG

OPERATING SYSTEM AND A HIGHLY MODIFIED VERSION OF AMERICAN

MICROSYSTEMS PROTO OPERATING SYSTEM. SYSTEM INITIALIZATION

ON POWER UP RESET OR EXTERNAL RESET CONFIGURES ALL INPUT/OUTPUT

DEVICES, PERFORMS A ROM TO RAM OVERLAY AS APPLICABLE, SIZES AND

TESTS RAM MEMORY, AND JUMPS TO THE PROTO PORTION OF THE OPERATING

SYSTEM.

get navdef.a ;NAV COMPUTER EQUATES AND SYS RAM USAGE

NAVDEF.A DEFINES THE INPUT/OUTPUT AND SYSTEM RAM USAGE FOR
THE MARRS-1 NAVIGATION COMPUTER

SEE APPENDIX D FOR A COMPLETE LISTING OF NAVDEF.A

E055	8D 53	MBYTE	BSR MINHEX
E057	48		ASLA
E058	48		ASLA
E059	48		ASLA
E05A	48		ASLA
E05B	16		TAB
E05C	8D 4C		BSR MINHEX
E05E	1B		ABA
E05F	16		TAB
E060	FB A0 0A		ADDB MCKSM
E063	F7 A0 0A		STAB MCKSM
E066	39		RTS
E067	44	MOUTH	LSRA
E068	44		LSRA
E069	44		LSRA
E06A	44		LSRA
E06B	84 0F	MOUTH	ANDA #0FH
E06D	88 30		ADDA #30H
E06F	81 39		CMPA #39H
E071	23 02		BLS MOUTCH
E073	88 07		ADDA #07
E075	7E E1 D1	MOUTCH	JMP MOUTEEE
E078	7E E1 AC	MINCH	JMP MINEEE
E07B	8D F8	MPDATA2	BSR MOUTCH
E07D	08		INX
E07E	A6 00	MPDATA1	LDAA 00,X
E080	81 04		CMPA #04
E082	26 F7		BNE MPDATA2
E084	39		RTS
E085	8D C0	MCHANGE	BSR MBADDR
E087	CE E1 9D	MCHAS1	LDX #MCHL
E08A	8D F2		BSR MPDATA1
E08C	CE A0 0C		LDX #MXHI
E08F	8D 37		BSR MOUT4HS
E091	FE A0 0C		LDX #XHI
E094	8D 34		BSR MOUT2HS
E096	FF A0 0C		STX #XHI
E099	8D DD		BSR MINCH
E09B	81 20		CMPA #20H
E09D	26 E8		BNE MCHAS1
E09F	8D B4		BSR MBYTE
E0A1	09		DEX
E0A2	A7 00		STAA 00,X
E0A4	A1 00		CMPA 00,X
E0A6	27 DF		BEQ MCHAS1
E0A8	20 96		BRA MLOAD19
E0AA	8D CC	MINHEX	BSR MINCH
E0AC	80 30		SUBA #30H
E0AE	2B 94		BMI MCI
E0B0	81 09		CMPA #09
E0B2	2F 0A		BLE MINIHC
E0B4	81 11		CMPA #11H

E0B6	28 8C		BNI MC1
E0B8	81 16		CHPA #16H
E0BA	2E 88		BGT MC1
E0BC	80 07		SUBA #07
E0BE	39	MIN1HC	RTS
E0BF	A6 00	MOUT2H	LDA #00,X
E0C1	8D A7		BSR MOUTH
E0C3	A6 00		LDA #00,X
E0C5	08		INX
E0C6	20 A3		BRA MOUTH
E0C8	8D F3	MOUT4HS	RSR MOUT2H
E0CA	8D F3	MOUT2HS	BSR MOUT2H
E0CC	86 20	MOUTS	LDA #20H
E0CE	20 A5	MOUTS2	BRA MOUTCH
E0D0	CE BF F3		LDX #MACIAI
E0D3	8E 00 00		LDS #MACIA
E0D6	AF 00		STS #00,X
E0D8	8E E0 00		LDS #M10
E0DB	AF 03		STS #3,X
E0DD	8E E1 13		LDS #MSFE
E0E0	AF 06		STS #6,X
E0E2	01		NOP
E0E3	8E E0 05	MCONTRL	LDS #MPONDAN
E0E6	AF 09		STS #9,X
E0E8	8E A0 42		LDS #MSTACK
E0EB	BF A0 08		STS MSP
E0EE	CE E1 9C		LDX #MNCLOFF
E0F1	8D 88		BSR MPDATAI
E0F3	8D 83		BSR MINCH
E0F5	16		TAB
E0F6	8D D4		BSR MOUTS
E0F8	C1 4C		CHPB #4CH
E0FA	26 03		BNE MCONTRL2
E0FC	7E E0 0A		JMP MLOAD
E0FF	C1 4D	MCONTRL2	CHPB #4DH
E101	27 82		BEQ MCHANGE
E103	C1 52		CHPB #52H
E105	27 18		BEQ MPRINT
E107	C1 50		CHPB #50H
E109	27 32		BEQ MPUNCH
E10B	C1 47		CHPB #47H
E10D	26 D4		BNE MCONTRL
E10F	BE A0 08		LDS MSP
E112	3B		RTI
E113	BF A0 08	MSFE	STS MSP
E116	30		TSX
E117	6D 06		TST #6,X
E119	26 02		BNE MSFE1
E11B	6A 05		DEC #5,X
E11D	6A 06	MSFE1	DEC #6,X
E11F	FE A0 08	MPRINT	LDX MSP
E122	08		INX

E123	80 A5		BSR MOUT2HS
E125	80 A3		BSR MOUT2HS
E127	80 A1		BSR MOUT2HS
E129	80 9D		BSR MOUT4HS
E12B	80 9B		BSR MOUT4HS
E12D	CE A0 09		LDX #MSP
E130	80 96		BSR MOUT4HS
E132	20 AF	MC2 BRA	MCONTRL
E134	0D	MNTAPE1	FCB 0DH
E135	0A		FCB 0AH
E136	C0		FCB 00
E137	00		FCB 00
E138	00		FCB 00
E139	00		FCB 00
E13A	53		FCB 53H
E13B	31		FCB 31H
E13C	04		FCB 04
E13D	86 12	MPUNCH	LDA #12H
E13F	BD E0 75		JSR MOUTCH
E142	FE A0 02		LDX #BEGA
E145	FF A0 0F		STX #TW
E148	B6 A0 05	MPUN11	LDA #MEND1
E14B	B0 A0 10		SUB #M1
E14E	F6 A0 04		LDA #MEND1
E151	F2 A0 0F		SBC #M1
E154	26 04		BNE #MPUN22
E156	81 10		CPA #10H
E158	25 02		BCS #M1
E15A	86 0F	MPUN22	LDA #0FH
E15C	8B 04	MPUN23	ADDA #04
E15E	B7 A0 11		STAA #MCONT
E161	80 03		SUB #03
E163	B7 A0 0E		STAA #MTEMP
E166	CE E1 34		LDX #MNTAPE1
E169	BD E0 7E		JSR #MPDATA1
E16C	5F		CLRB
E16D	CE A0 11		LDX #MCONT
E170	8D 25		BSR #PUNT2
E172	CE A0 0F		LDX #M1
E175	8D 20		BSR #PUNT2
E177	8D 1E		BSR #PUNT2
E179	FE A0 0F		LDX #M1
E17C	8D 19	MPUN32	BSR #PUNT2
E17E	7A A0 0E		DEC #MTEMP
E181	26 F9		BNE #MPUN32
E183	FF A0 0F		STX #M1
E186	53		COMB
E187	37		PSHB
E188	30		TSX
E189	8D 0C		BSR #PUNT2
E18B	33		PULB
E18C	FE A0 0F		LDX #M1

E18F	09		DEX
E190	BC A0 04		CPX MENDA
E193	26 B3		ENE MPUN11
E195	20 9B		BRA MC2
E197	EB 00	PUNT2	ADD8 00, X
E199	7E E0 BF		JMP HGUT2H
E19C	13	MMCLOFF	FCB 13H
E19D	0D	MMCL	FCB 0DH
E19E	0A		FCB 0AH
E19F	14		FCB 14H
E1A0	00		FCB 00
E1A1	00		FCB 00
E1A2	00		FCB 00
E1A3	2A		FCB 2AH
E1A4	04		FCB 04
E1A5	FF A0 12	MSAV	STX MIXTEMP
E1A8	FE BF F5		LDX MACIAI
E1AB	39		RTS
E1AC	37	MINEEE	PSHB
E1AD	8D F6		BSR MSAV
E1AF	EE 00		LDX 00, X
E1B1	A6 00	MINOEK0	LDA 00, X
E1B3	47		ASRA
E1B4	24 FB		BCC MINOEK0
E1B6	A6 01		LDA 01, X
E1B8	84 7F		ANDA 07FH
E1BA	36	MINOEK1	PSHA
E1BB	A6 00	MINOEK2	LDA 00, X
E1BD	85 02		BITA 02
E1BF	27 FA		BEQ MINOEK2
E1C1	32		PULA
E1C2	A7 01		STAA 01, X
E1C4	20 24		BRA M10S
E1C6	01		NOP
E1C7	01		NOP
E1C8	01		NOP
E1C9	01		NOP
E1CA	01		NOP
E1CB	01		NOP
E1CC	01		NOP
E1CD	01		NOP
E1CE	01		NOP
E1CF	01		NOP
E1D0	01		NOP
E1D1	37	MOUTEEE	PSHB
E1D2	8D D1		BSR MSAV
E1D4	EE 00		LDX 00, X
E1D6	20 E2		BRA MINOEK1
E1D8	01		NOP
E1D9	01		NOP
E1DA	01		NOP
E1DB	01		NOP

;INPUT WITH ECHO THRU ACIA WITH NO PARITY

E1DC	01		NOP
E1DD	01		NOP
E1DE	01		NOP
E1DF	01		NOP
E1E0	01		NOP
E1E1	01		NOP
E1E2	01		NOP
E1E3	01		NOP
E1E4	01		NOP
E1E5	01		NOP
E1E6	01		NOP
E1E7	01		NOP
E1E8	01		NOP
E1E9	01		NOP
E1EA	FE A0 12	MIOS	LDX MXTMP
E1ED	33		PULB
E1EE	39		RTS

```

;
;
;      END OF MSBUG (SERIAL VERSION OF MIKBUG (SEE MOTOROLA
;      ENGINEERING NOTE 100) )
;
;
;

```

E1EF

```

;*****
;      get nbug3.a          ;HIGHLY MODIFIED VERSION OF PROTO
;
;
;

```

```

;      NBUG3.A          (NEW BUG)
;
;
;

```

```

;      PROTO OPERATING SYSTEM VERSION 3.0
;      (HIGHLY MODIFIED FOR HGS/TEC BUILT 6802/6808 COMPUTERS)
;
;
;

```

```

;      26 SEPTEMBER 1984 -- LT TOM CLIFFORD, CAPT BERT SCHNEIDER
;      SEE AMI 6800 PROTOTYPING BOARD MANUAL FOR COMPLETE
;      SOURCE CODE LISTING
;
;

```

E1EF	8E BE 00	START	LDS #USRSTAK
E1F2	BF BF F1		STS SREG
E1F5	7E E1 FD		JMP START1
E1F8	7E E2 91	BREAK	JMP BREAK1
E1FB	C0 00	ACTAA	FDB IO+ACTAT
E1FD	36	START1	PSHA
E1FE	07		TPA
E1FF	B7 BF EA		STAA CREG
E202	32		PULA
E203	B7 BF EC		STAA AREG
E206	F7 BF EB		STAB BREG
E209	FF BF ED		STX XREG
E20C	BF BF F1		STS SREG
E20F	8E BE 7F		LDS #BOS
E212	CE E1 F8		LDX #BREAK
E215	FF BF FE		STX NHIVEC+1
E218	01		NOP
E219	01		NOP

```

;      ;THESE THREE LINES MAY BE REPLACED WITH:
;      ;      STX IRGVEC+1
;

```

E21A	01		NOP		;THE THREE NOPS ARE USED TO KEEP A STANDARD ;CONFIGURATION OF THE ROM SUBROUTINE ADDRESSES ;FROM ONE COMPUTER TO ANOTHER RUNNING NEW BUG.
E21B	06 7E		LDA #7EH		
E21D	B7 BF F7		STAA IRQVEC		
E220	B7 BF FA		STAA SWIVEC		
E223	B7 BF FD		STAA NMIVEC		
E226	CE E2 A8		LDX #SWI30		
E229	FF BF F3		STX USWI		
E22C	CE E2 95		LDX #SWIHAN		
E22F	FF BF FB		STX SWIVEC+1		
E232	CE E1 FB		LDX #ACIAA		
E235	FF BF F3		STX ACIAI		
E238	06 03		LDA #03		
E23A	B7 C0 00		STAA IO+ACIAT		
E23D	06 15		LDA #15H		
E23F	B7 C0 00		STAA IO+ACIAT		
E242	BD E5 2A	MONENT	JSR PCRLF		
E245	9E 7E 7F	MONITR	LDS #BOS		
E248	B6 C0 01		LDA IO+ACIAT+A.RX		
E24B	06 3E		LDA #3EH		
E24D	BD E5 08		JSR OUTCH		
E250	CE BF 80		LDX #BUF		
E253	FF BF D0		STX BUFPTR		
E256	00		SEC		
E257	79 BF E8		ROL ECHO		
E25A	8C BF C7	RT10	CPX #BUFEND		
E25D	26 02		BNE RT20		
E25F	20 26		BRA ABORT		
E261	BD E6 11	RT20	JSR WAITTY		
E264	A7 00		STAA 00,X		
E266	00		INX		
E267	01 00	RT90	CPA 00DH		
E269	26 EF		BNE RT10		
E26B	BD E5 AC		JSR PEXISTS		
E26E	00		INX		
E26F	FF BF D0		STX BUFPTR		
E272	CE E8 82		LDX #CTABLE		
E275	A1 00	DLOOP	CPA 00,X		
E277	26 04		BNE DL10		
E279	EE 01		LDX 01,X		
E27B	6E 00		JMP 00,X		
E27D	00	DL10	INX		
E27E	00		INX		
E27F	00		INX		
E280	8C E8 A3		CPX #QBADR		
E283	26 F0		BNE DLOOP		
E285	20 00		BRA ABORT		
E287	CE E8 B9	ABORT	LDX #GQUES		
E28A	8E BE 7F	MSGNON	LDS #BOS		
E28D	3F		SWI		
E28E	12		FCB 12H		

E28F	20 B1		BRA MONENT	
E291	86 80	BREAK1	LDA #00H	
E293	20 1A		BRA SW140	
E295	30	SWIHAN	TSX	
E296	EE 05		LDX #5, X	
E298	A6 00		LDA #0, X	
E29A	28 0C		BMI SW130	
E29C	80 18		SUBA #18H	
E29E	2A 03		BPL SW120	
E2A0	7E E6 5A		JMP RSRSR	
E2A3	FE BF F3	SW120	LDX USWI	
E2A6	6E 00		JMP #0, X	
E2A8	30	SW130	TSX	
E2A9	6C 06		INC #6, X	
E2AB	26 02		BNE SW140	
E2AD	6C 05		INC #5, X	
E2AF	CE BF EA	SW140	LDX #CREG	
E2B2	33	SW150	PULB	
E2B3	E7 00		STAB #0, X	
E2B5	08		INX	
E2B6	8C BF F1		CPX #SREG	
E2B9	26 F7		BNE SW150	
E2BB	AF 00		STS #0, X	
E2BD	81 81		CMPA #81H	
E2BF	26 04		BNE PREGS	
E2C1	80 07		BSR PR1	
E2C3	20 2C		BRA RESTAK	
E2C5	80 03	PREGS	BSR FR1	
E2C7	7E E2 45		JMP MONITR	
E2CA	BD E5 2A	PR1	JSR PCRLF	;PRINT CRLF
E2CD	CE E8 EB		LDX #REGNAM	;POINT TO PROMPT STRING
E2D0	3F		SWI	
E2D1	12		FCB 12H	;AND PRINT IT
E2D2	BD E5 2A		JSR PCRLF	;PRINT CRLF
E2D5	CE BF EA		LDX #CREG	;POINT TO TEMPORARY REGISTERS
E2D8	C6 03		LDAB #03	;PRINT 3 SINGLE BYTE REGISTERS
E2DA	3F	PR10	SWI	
E2DB	0F		FCB 0FH	
E2DC	BD E5 A7		JSR PSPACE	;WITH A SPACE BETWEEN EACH PAIR
E2DF	5A		DECB	;OF HEX CHARACTERS
E2E0	2E F8		BGT PR10	
E2E2	C6 03		LDAB #03	;NOW PRINT 3 TWO BYTE REGISTERS
E2E4	BD E5 A5	PR20	JSR P4HEXS	;WITH A SPACE BETWEEN FOUR
E2E7	BD E5 A7		JSR PSPACE	;HEX CHARACTERS
E2EA	5A		DECB	
E2EB	2E F7		BGT PR20	
E2ED	BD E5 2A		JSR PCRLF	
E2F0	39		RTS	
E2F1	BE BF F1	RESTAK	LDS SREG	
E2F4	CE BF F0		LDX #PREG+1	
E2F7	A6 00	RUS10	LDA #0, X	
E2F9	36		PSHA	

E2FA	09		DEX	
E2FB	8C BF E9		CPI #TCOUNT	
E2FE	26 F7		BNE RUS10	
E300	38		RTI	
E301	B6 BF D4	CHEKSH	LDAA CKSUM	
E304	36		PSHA	
E305	80 E4 CC		JSR NEX20	
E309	33		PULB	
E309	53		COMB	
E30A	11		CBA	
E30B	26 01		BNE CSI	
E30D	39		RTS	
E30E	30	CSI	TSX	
E30F	09		DEX	
E310	3F		SWI	
E311	0F		FCB 0FH	
E312	80 E5 A7		JSR PSPACE	
E315	CE E8 BE		LDX #CKSHR	
E318	39		RTS	
E319	36	READACI	PSHA	;LILBUG READ PORT WITHOUT WAIT
E31A	B6 C0 01		LDAA IO+ACIAT+A.RX	
E31D	84 7F		ANDA #7FH	;CLEAR PARITY BIT
E31F	81 17		CHPA #17H	;IS IT CONTROL W ?
E321	26 02		BNE ISCTRLX	;IF SO WAIT FOR FURTHER INPUT
E323	3F		SWI	;BEFORE CONTINUING
E324	14		FCB 14H	
E325	81 18	ISCTRLX	CHPA #18H	;IS IT CONTROL X ?
E327	32		PULA	;IF YES THEN CC IS SET
E328	39	RET39	RTS	
E329	84 0F	CONV4	ANDA #0FH	;LILBUG CONVERT RIGHT 4 BITS AND
E32B	88 90		ADDA #90H	;PRINT ROUTINE
E32D	19		DAA	
E32E	89 40		ADCA #40H	
E330	19		DAA	
E331	3F		SWI	
E332	11		FCB 11H	
E333	39		RTS	
E334	08	ROZR2P2	INX	;Advance compare TO pointer
E335	FF BF D9		STX TEMP2	;Save compare TO pointer
E338	FE BF D7	CPRMEM	LDX TEMP1	;Fetch compare pointer
E338	A6 00		LDAA 0,X	;Fetch compare data
E33D	08		INX	;Advance compare pointer
E33E	FF BF D7		STX TEMP1	;Store compare pointer
E341	FE BF D9		LDX TEMP2	;Fetch compare TO pointer
E344	A1 00		CHPA 0,X	;Compare A to indexed data
E346	26 03		BNE CPRET	;If not equal, return
E348	5A		DECB	;Decremnt byte counter
E349	26 E9		BNE ROZR2P2	;Counter <>0, continue comparing
E34B	39	CPRET	RTS	;Return with flags conditioned
E34C	8D E3 F0	DISHM1	JSR GETRND	;DISPLAY MEMORY ROUTINE STARTS HERE
E34F	8D 03		BSR DISMEM1	
E351	7E E2 42		JMP MOMENT	

E354	CE BF CC	DISHEN1	LXI #ADDL	;POINT TO THE 'FROM' ADDRESS
E357	A6 01		LDAA 01,X	;GET LOW ORDER PART OF ADDRESS
E359	84 F0		ANDA #0F0H	;MASK LOW ORDER 4 BITS
E35B	A7 01		STAA 01,X	;RETURN NEW LOW ORDER PART OF ADDRESS
E35D	FE BF CE		LXI ADDH	;GET THE 'TO' ADDRESS
E360	09		DEX	;MAKE IT WHAT THE USER SAID IT WAS TO BE
E361	3F		SWI	;
E362	02		FCB 02H	;
E363	CA 0F		ORAB #0FH	;SET LOW ORDER 4 BITS
E365	3F		SWI	;
E366	03		FCB 03H	;
E367	FF BF CE		STX ADDH	;RESTORE NEW 'TO' ADDRESS
E36A	BD E5 2A	BYTENUM	JSR PCRLF	;PRINT BYTE NUMBER GUIDE LINE BY FIRST PRINTING CRLF
E36D	BD E5 2A		JSR PCRLF	;TWICE
E370	CE E8 E4		LXI #06SPACE	;PRINT 6 LEADING SPACES
E373	3F		SWI	
E374	12		FCB 12H	
E375	4F		CLRA	
E376	36	BYTENM1	PSHA	;CONVERT RIGHT 4 BITS AND PRINT AS ASCII
E377	BD E3 29		JSR CONV4	;UPPER CASE CHARACTER
E37A	BD E5 A7		JSR PSPACE	;PRINT TWO
E37D	BD E5 A7		JSR PSPACE	;SPACES
E380	32		PULA	;GET COUNTER
E381	4C		INCA	;HAVE WE PRINTED
E382	81 10		CMPA #10H	;HEX NUMBERS 0 THRU F?
E384	26 F0		BNE BYTENM1	;KEEP PRINTING THEM IF NOT FINISHED
E386	8D 91	OUTLOOP	BSR READAC1	;CHECK FOR PRINT END OR WAIT FROM USER
E388	27 57		BEQ ENDOM	;END PRINT IF CONTROL X KEY WAS HIT
E38A	BD E5 2A		JSR PCRLF	;ELSE CONTINUE PRINT WITH CRLF
E38D	CE BF CC		LXI #ADDL	;GET ADDRESS OF DATA TO BE PRINTED
E390	BD E5 A5		JSR P4HEX5	;PRINT ADDRESS AS 4 HEX WITH A SPACE
E393	FE BF CC		LXI ADDL	;POINT TO THE DATA
E396	C6 10		LDAB #10H	;SET UP A COUNTER FOR 16 BYTES
E398	3F	INLOOP1	SWI	;PRINT BYTE AS TWO HEX AND POINT TO NEXT BYTE
E399	0F		FCB 0FH	
E39A	BD E5 A7		JSR PSPACE	;PRINT A SPACE
E39D	5A		DECB	;ONE LESS BYTE TO PRINT
E39E	26 FB		BNE INLOOP1	;PRINT NEXT BYTE IF NOT DONE
E3A0	BD E5 A7		JSR PSPACE	;PRINT ANOTHER SPACE
E3A3	C6 10		LDAB #10H	;NOW PRINT THE 16 BYTES AS ASCII IF POSSIBLE
E3A5	FE BF CC		LXI ADDL	;POINT TO THE FIRST BYTE
E3A8	A6 00	INLOOP2	LDAA 00,X	;GET THE BYTE
E3AA	84 7F		ANDA #7FH	;STRIP OFF EIGHTH BIT
E3AC	81 20		CMPA #20H	;IF BYTE IS LESS THAN ASCII SPACE
E3AE	2D 04		BLT PERIOD	;PRINT A PERIOD
E3B0	81 61		CMPA #61H	;ELSE CHECK TO SEE IF IT IS A PRINTABLE CHARACTER
E3B2	2D 02		BLT PRNTASC	
E3B4	86 2E	PERIOD	LDAA #2EH	;NOT PRINTABLE SO PRINT A PERIOD
E3B6	3F	PRNTASC	SWI	;PRINT THE CHARACTER OR A PERIOD
E3B7	11		FCB 11H	
E3B8	08		INX	;POINT TO NEXT BYTE
E3B9	5A		DECB	;ONE LESS TO PRINT

E38A	26 EC	BNE INLOOP2	;GO PRINT THE REST OF THE 16 BYTES
E38C	09	DEX	;POINT TO THE LAST BYTE PRINTED
E38D	FF BF CC	STX ADDL	;SAVE THE ADDRESS
E3C0	CE BF CC	LDX #ADDL	;GET A POINTER TO THE LAST BYTE PRINTED
E3C3	FF BF D7	STX TEMP1	;SAVE THE POINTER FOR COMPARISON
E3C6	CE BF CE	LDX #ADDH	;GET A POINTER TO THE LAST BYTE TO BE PRINTED
E3C9	FF BF D9	STX TEMP2	;SAVE THE POINTER FOR COMPARISON
E3CC	C6 02	LDAB #02	;THE POINTERS ARE 2 BYTES EACH
E3CE	BD E3 38	JSR CPRMEM	;COMPARE ADDRESSES
E3D1	22 0E	BHI ENDM	;BRANCH IF FINISHED WITH MEMORY PRINT
E3D3	FE BF CC	LDX ADDL	;ELSE GET THE ADDRESS OF LAST BYTE PRINTED
E3D6	00	INX	;AND POINT TO NEXT BYTE TO BE PRINTED
E3D7	FF BF CC	STX ADDL	;SAVE THE ADDRESS
E3DA	7D BF CD	TST ADDL+1	;IF WE HAVE PRINTED A BLOCK OF DATA
E3DD	26 A7	BNE OUTLOOP	;THEN GO PRINT THE BYTE NUMBER GUIDE LINE AND 16 BYTES
E3DF	20 89	BRA BYTENUM	;ELSE GO PRINT NEXT 16 BYTES
E3E1	39	ENDM RTS	;RETURN TO CALLER
E3E2	8D 03	EOF BSR EOF1	
E3E4	7E E2 42	JMP MOMENT	
E3E7	CE E8 D0	EOF1 LDX #OTPEOF	
E3EA	3F	SMT	
E3EB	12	FCB 12H	
E3EC	BD E5 2A	JSR PCRLF	
E3EF	39	RTS	
E3F0	BD E4 E6	GETRNG JSR NXTADR	
E3F3	FE BF CA	LDX ADR	
E3F6	FF BF CC	STX ADDL	
E3F9	FF BF CE	STX ADDH	
E3FC	BD E4 E6	JSR NXTADR	
E3FF	27 06	BEQ GETRG3	
E401	FE BF CA	GETRG1 LDX ADR	
E404	FF BF CE	STX ADDH	
E407	CE BF 80	GETRG3 LDX #BUF	
E40A	A6 4E	LDAA 4EH,X	
E40C	E6 4F	LDAB 4FH,X	
E40E	E0 4D	SUBB 4DH,X	
E410	A2 4C	SBCA 4CH,X	
E412	24 04	BCC GETRG4	
E414	CE E8 AB	RNGERR LDX #RNGERR	
E417	39	RTS	
E418	FE BF CE	GETRG4 LDX ADDH	
E41B	00	INX	
E41C	FF BF CE	STX ADDH	
E41F	39	RTS	
E420	BD E4 E6	GO JSR NXTADR	
E423	27 06	BEQ GO10	
E425	FE BF CA	LDX ADR	
E428	FF BF EF	STX PREG	
E42B	7E E2 F1	GO10 JMP RESTAK	
E42E	8D 03	LOAD BSR LOAD2	
E434	7E E2 8A	JMP MSGMON	
E433	CE 00 00	LOAD2 LDX #XZERO	

E436	FF BF C8		STX OFFSET
E439	FF BF CC		STX ADDL
E43C	09	LOOFST	TEX
E43D	FF BF CE		STX ADDH
E440	BD E4 E6		JSR NXTADR
E443	27 1E		BEQ LOAD1
E445	FE BF CA		LDX ADR
E448	FF BF C8		STX OFFSET
E44B	BD E4 E6		JSR NXTADR
E44E	27 13		BEQ LOAD1
E450	FE BF C8		LDX OFFSET
E453	FF BF CC		STX ADDL
E456	CE 00 00		LDX #XZERO
E459	FF BF C8		STX OFFSET
E45C	8D A3		BSR GETR01
E45E	FE BF CF		LDX ADDH
E461	20 D9		BRA LOOFST
E463	01	LOAD1	NOP
E464	8D 5D	ROPRE	BSR FINDS
E466	BD E6 11		JSR WAITTY
E469	81 30		CHPA #30H
E46B	27 F7		BEQ ROPRE
E46D	B7 BF D2		STAA RECTYP
E470	7F BF 04		CLR CKSUM
E473	BD E4 CC		JSR NEX2D
E476	4A		DECA
E477	4A		DELA
E478	4A		DECA
E479	B7 BF D3		STAA COUNT
E47C	BD E4 CC		JSR NEX2D
E47F	B7 BF CA		STAA ADR
E482	BD E4 CC		JSR NEX2D
E485	B8 BF C9		ADDA OFFSET+1
E488	B7 BF CB		STP., ADR+1
E48B	B6 BF CA		LDAA ADR
E48E	B9 BF C8		ADCA OFFSET
E491	B7 BF CA		STAA ADR
E494	B6 BF D2		LDAA RECTYP
E497	81 31		CHPA #31H
E499	26 14		BNE LHF4
E49B	BD E4 CC	LDR10	JSR NEX2D
E49E	FE BF CA		LDX ADR
E4A1	BD E3 C2		JSR SETOFF
E4A4	08		INX
E4A5	FF BF CA		STX ADR
E4A8	7A BF D3		DEC COUNT
E4AB	2E EE		BGT LDR10
E4AD	20 04		BRA LHF9
E4AF	81 39	LHF4	CHPA #39H
E4B1	26 0E		BNE BADTAP
E4B3	BD E3 01	LHF9	JSR CHEKSH
E4B6	B6 BF D2		LDAA RECTYP

E4B9	81 39		CMPA #39H
E4BB	26 A6		BNE LOAD1
E4BD	CE E8 B5		LDX #GE0F
E4C0	39		RTS
E4C1	20 A1	BADTAP	BRA ROPRE
E4C3	01	FINDS	NOP
E4C4	80 E6 11	FS10	JSR WAITTY
E4C7	81 53		CMPA #53H
E4C9	26 F9		BNE FS10
E4CB	39		RTS
E4CC	80 E6 11	NEX20	JSR WAITTY
E4CF	16		TAB
E4D0	80 E6 11		JSR WAITTY
E4D3	36		PSHA
E4D4	37		PSHB
E4D5	30		TSX
E4D6	C6 #2		LDAB #02
E4D8	3F		SMT
E4D9	15		FCB 15H
E4DA	24 E5		BCC BADTAP
E4DC	17		TBA
E4DD	FB BF D4		ADDB CKSUM
E4E0	F7 BF D4		STAB CKSUM
E4E3	31		INS
E4E4	31		INS
E4E5	39		RTS
E4E6	7F BF CA	NXTADR	CLR ADR
E4E9	7F BF CB		CLR ADR+1
E4EC	80 E5 AC		JSR PEXISTS
E4EF	26 01		BNE NA1
E4F1	39	NXTRTS	RTS
E4F2	C6 47	NA1	LDAB #47H
E4F4	3F		SMT
E4F5	15		FCB 15H
E4F6	FF BF D0		STX BUFPTR
E4F9	B7 BF CA		STAA ADR
E4FC	F7 BF CB		STAB ADR+1
E4FF	A6 00		LDA #00,X
E501	3F		SMT
E502	13		FCB 13H
E503	25 01		BCS NA3
E505	39		RTS
E506	7E E2 87	NA3	JMP ABORT
E509	A6 00	OUTCHX	LDA #00,X
E50B	37	OUTCh	PSHB
E50C	F6 C0 00		LDAB 10+ACIAT
E50F	57		ASRB
E510	24 0A		BCC OC10
E512	F6 C0 01		LDAB 10+ACIAT+A.RX
E515	C1 1B		CMPB #1BH
E517	26 03		BNE OC10
E519	7E E2 87		JMP ABORT

E51C	3F	OC10	SWI
E51D	11		FCB 11H
E51E	81 0D		CMPA #0DH
E520	26 06		BNE OC20
E522	86 0A		LDAA #0AH
E524	3F		SWI
E525	11		FCB 11H
E526	86 0D		LDAA #0DH
E527	33	OC20	PULB
E529	39		RTS
E52A	86 0D	PCRLF	LDAA #0DH
E52C	20 DD		BRA OUTCH
E52E	8D 03	PUNCH	BSR PUNCH1
E530	7E E2 42		JMP MOMENT
E533	BD E3 F0	PUNCH1	JSR GETRNG
E536	CE 00 06		LDX #XZERO
E539	FF BF C8		STX OFFSET
E53C	8D A8		BSR NXTADR
E53E	27 06		BEQ PHF20
E540	FE BF CA		LDX ADR
E543	FF BF C8		STX OFFSET
E546	F6 BF CF	PHF20	LDAB ADDH+1
E549	F0 BF CD		SUBB ADDL+1
E54C	B6 BF CE		LDAA ADDH
E54F	B2 BF CC		SBCA ADDL
E552	26 04		BNE PUND10
E554	C1 10		CMPB #10H
E556	23 02		BLS PUND20
E558	C6 10	PUND10	LDAB #10H
E55A	5C	PUND20	INCB
E55B	5C		INCB
E55C	5C		INCB
E55D	F7 BF D3		STAB COUNT
E560	CE E8 DB		LDX #QSI
E563	3F		SWI
E564	12		FCB 12H
E565	5F		CLRB
E566	CE BF D3		LDX #COUNT
E569	8D 32		BSR PUNBYTE
E56B	37		PSHB
E56C	FE BF CC		LDX ADDL
E56F	B6 BF C8		LDAA OFFSET
E572	F6 BF C9		LDAB OFFSET+1
E575	3F		SWI
E576	08		FCB 08
E577	FF BF CA		STX ADR
E57A	CE BF CA		LDX #ADR
E57D	33		PULB
E57E	8D 1D		BSR PUNBYTE
E580	8D 1B		BSR PUNBYTE
E582	FE BF CC		LDX ADDL
E585	8D 16	PREC10	BSR PUNBYTE

E587	2E FC		BGT PREC10
E589	FF BF CC		STX ADDL
E58C	CE BF D4		LDX #CKSUM
E58F	53		COMB
E590	E7 00		STAB 00,X
E592	80 09		BSR PUNBYTE
E594	FE BF CC		LDX ADDL
E597	BC BF CE		CPX ADDH
E59A	26 AA		BNE PHF20
E59C	39		RTS
E59D	EB 00	PUNBYTE	ADDB 00,X
E59F	3F		SWI
E5A0	0F		FCB 0FH
E5A1	7A BF D3		DEC COUNT
E5A4	39		RTS
E5A5	3F	PAHEXS	SWI
E5A6	10		FCB 10H
E5A7	86 20	PSPACE	LDA #20H
E5A9	3F		SWI
E5AA	11		FCB 11H
E5AB	39		RTS
E5AC	FE BF D0	PEXISTS	LDX BUFPTR
E5AF	A6 00	PXISTX	LDA 00,X
E5B1	3F		SWI
E5B2	13		FCB 13H
E5B3	25 07		BCS PX2
E5B5	81 00		CHPA #0DH
E5B7	27 03		BEQ PX2
E5B9	08		INX
E5BA	20 F3		BRA PXISTX
E5BC	FF BF D0	PX2	STX BUFPTR
E5BF	81 00		CHPA #0DH
E5C1	39		RTS
E5C2	36	SETOFF	PSHA
E5C3	B6 BF CC		LDA ADDL
E5C6	F6 BF CD		LDAB ADDL+1
E5C9	3F		SWI
E5CA	0B		FCB 0BH
E5CB	22 0A		BHI SETOUT
E5CD	B6 BF CE		LDA ADDH
E5D0	F6 BF CF		LDAB ADDH+1
E5D3	3F		SWI
E5D4	0B		FCB 0BH
E5D5	24 07		BCC SETPUL
E5D7	32	SETOUT	PULA
E5D8	86 FF		LDA #0FFH
E5DA	3F		SWI
E5DB	11		FCB 11H
E5DC	20 15		BRA SETM1
E5DE	32	SETPUL	PULA
E5DF	A7 00	SETM1	STAA 00,X
E5E1	A1 00		CHPA 00,X

E5E3	27 0E		BEQ	SETH1
E5E5	FF BF CA		STX	ADR
E5E8	CE BF CA		LDX	#ADR
E5EB	8D B8		BSR	P4HEXS
E5ED	CE E8 A3	PBADR	LDX	#QBADR
E5F0	7E E2 8A		JMP	MSGMON
E5F3	39	SETH1	RTS	
E5F4	BD E4 E6	SM	JSR	NXTADR
E5F7	FE BF CA		LDX	ADR
E5FA	FF BF CC		STX	ADDL
E5FD	BD E4 E6	SM10	JSR	NXTADR
E600	27 0C		BEQ	SM30
E602	FE BF CC		LDX	ADDL
E605	17		TBA	
E606	8D D7		BSR	SETHEN
E608	08		INX	
E609	FF BF CC		STX	ADDL
E60C	20 EF		BRA	SM10
E60E	7E E2 45	SM30	JMP	MONITR
E611	3F	WAITTY	SM1	
E612	14		FCB	14H
E613	81 1B		CMPA	#1BH
E615	26 03		BNE	W20
E617	7E E2 87		JMP	ABORT
E61A	81 7F	W20	CMPA	#7FH
E61C	27 F3		BEQ	WAITTY
E61E	7D BF E8		TST	ECHO
E621	27 03		BEQ	W30
E623	BD E3 08		JSR	OUTCH
E626	39	W30	RTS	
E627	FE BF CC	INK	LDX	ADDL
E62A	08		INX	
E62B	FF BF CC		STX	ADDL
E62E	DC BF CE		CPX	ADDH
E631	26 02		BNE	ADDRS
E633	31		INS	
E634	31		INS	
E635	39	ADDRS	RTS	
E636	7E E5 ED	JBAD	JMP	PBADR
E639	8D 03	MOVE	BSR	MOVE2
E63B	7E E2 45		JMP	MONITR
E63E	BD E3 F0	MOVE2	JSR	GETRNG
E641	BD E4 E6		JSR	NXTADR
E644	27 F0		BEQ	JBAD
E646	FE BF CC	MOVE1	LDX	ADDL
E649	A6 00		LDA	#00,X
E64B	FE BF CA		LDX	ADR
E64E	BD E5 DF		JSR	SETHEN
E651	08		INX	
E652	FF BF CA		STX	ADR
E655	BD E6 27		JSR	INK
E658	20 EC		BRA	MOVE1

E65A	30	RSRSR	TSX
E65B	EE 05		LDX 05, X
E65D	4F		CLRA
E65E	E6 00		LDAB 00, X
E660	58		ASLB
E661	49		ROLA
E662	8D 00		BSR LOCW
E664	30	LOCW	TSX
E665	EB 01		ADDB 01, X
E667	A9 00		ADCA 00, X
E669	CB 24		ADDB #24H
E66B	89 01		ADCA #01
E66D	A7 00		STAA 00, X
E66F	E7 01		STAB 01, X
E671	EE 00		LDX 00, X
E673	EB 01		ADDB 01, X
E675	A9 00		ADCA 00, X
E677	30		TSX
E678	A7 00		STAA 00, X
E67A	E7 01		STAB 01, X
E67C	A6 02		LDA A 02, X
E67E	06		TAP
E67F	EE 00		LDX 00, X
E681	31		INS
E682	31		INS
E683	AD 00		JSR 00, X
E685	30		TSX
E686	6C 06		INC 06, X
E688	26 02		BNE RSRXIT
E68A	6C 05		INC 05, X
E68C	38	RSRXIT	RTI
E68D	34		DES
E68E	34		DES
E68F	34		DES
E690	34		DES
E691	34		DES
E692	C6 09		LDAB #09
E694	30		TSX
E695	A6 05	PS	LDA A 05, X
E697	A7 00		STAA 00, X
E699	08		INX
E69A	5A		DECB
E69B	26 F8		BNE PS
E69D	C6 05		LDAB #05
E69F	30		TSX
E6A0	A6 02	PC	LDA A 02, X
E6A2	A7 09		STAA 09, X
E6A4	08		INX
E6A5	5A		DECB
E6A6	26 F8		BNE PC
E6A8	39		RTS
E6A9	30		TSX

E6AA	C6 05		LDAB 005
E6AC	A6 09	TRC	LDA 09, X
E6AE	A7 02		STAA 02, X
E6B0	08		INX
E6B1	5A		DECB
E6B2	26 F8		BNE TRC
E6B4	C6 09		LDAB 009
E6B6	A6 03	RS	LDA 03, X
E6B8	A7 08		STAA 08, X
E6BA	09		DEX
E6BB	5A		DECB
E6BC	26 F8		BNE RS
E6BE	31		INS
E6BF	31		INS
E6C0	31		INS
E6C1	31		INS
E6C2	31		INS
E6C3	39		RTS
E6C4	30		TSX
E6C5	A6 05		LDA 05, X
E6C7	E6 06		LDAB 06, X
E6C9	A7 04	STAB	STAA 04, X
E6CB	E7 03		STAB 03, X
E6CD	39		RTS
E6CE	30		TSX
E6CF	A6 04	TABX1	LDA 04, X
E6D1	A7 05		STAA 05, X
E6D3	A6 03		LDA 03, X
E6D5	A7 06		STAA 06, X
E6D7	39		RTS
E6D8	30		TSX
E6D9	A6 05	XABX1	LDA 05, X
E6DB	36		PSHA
E6DC	E6 06		LDAB 06, X
E6DE	8D EF		BSR TABX1
E6E0	32		PULA
E6E1	20 E6		BRA STAB
E6E3	34		DES
E6E4	34		DES
E6E5	30		TSX
E6E6	86 09		LDA 009
E6E8	E6 02	MA	LDAB 02, X
E6EA	E7 00		STAB 00, X
E6EC	03		INX
E6ED	4A		DECA
E6EE	26 F8		BNE MA
E6F0	30		TSX
E6F1	A6 05		LDA 05, X
E6F3	A7 09		STAA 09, X
E6F5	A6 06		LDA 06, X
E6F7	A7 0A		STAA 0AH, X
E6F9	39		RTS

E6FA	30		TSX
E6FB	A6 09		LDA 09, X
E6FD	A7 05		STAA 05, X
E6FF	A6 0A		LDA 0AH, X
E701	A7 06		STAA 06, X
E703	86 09		LDA 099
E705	E6 08	PULXA	LDAB 08, X
E707	E7 0A		STAB 0AH, X
E709	09		DEX
E70A	4A		DECA
E70B	26 F8		BNE PULXA
E70D	31		INS
E70E	31		INS
E70F	39		RTS
E710	30		TSX
E711	8D C6		BSR XABX1
E713	8D 03		BSR ADDABX1
E715	20 C2		BRA XABX1
E717	30		TSX
E718	A6 03	ADDABX1	LDA 03, X
E71A	E6 04		LDAB 04, X
E71C	AB 06	ADDAB	ADD 06, X
E71E	A7 06		STAA 06, X
E720	E9 05		ADCB 05, X
E722	07	STAUHX	TPA
E723	E7 05		STAB 05, X
E725	6D 06		TST 06, X
E727	27 02	TESTZ	BEQ TA
E729	84 FB		ANDA 00FBH
E72B	A7 02	TA	STAA 02, X
E72D	39		RTS
E72E	30		TSX
E72F	A6 04		LDA 04, X
E731	C6 00	ADDZ	LDAB 00
E733	20 E7		BRA ADDAB
E735	30		TSX
E736	A6 03		LDA 03, X
E738	20 F7		BRA ADDZ
E73A	30		TSX
E73B	8D 9C		BSR XABX1
E73D	8D 03		BSR SUBABX1
E73F	20 98		BRA XABX1
E741	30		TSX
E742	E6 05	SUBABX1	LDAB 05, X
E744	A6 06		LDA 06, X
E746	A0 03		SUBA 03, X
E748	A7 06		STAA 06, X
E74A	E2 04		SBCB 04, X
E74C	20 D4		BRA STAUHX
E74E	30		TSX
E74F	E6 04		LDAB 04, X
E751	A6 06	TSUB	LDAB 06, X

E753	10		SBA
E754	A7 06		STAA 06, X
E756	E6 05		LDAB 05, X
E758	C2 00		SBCB 000
E75A	20 C6		BRA STAUXH
E75C	30		TSX
E75D	E6 03		LDAB 03, X
E75F	20 F0		BRA TSUB
E761	80 11		BSR MPY8
E763	37		PSHB
E764	16		TAB
E765	32		PULA
E766	30		TSX
E767	20 B3		BRA ADDAB
E769	80 09		BSR MPY8
E76B	30		TSX
E76C	E7 03		STAB 03, X
E76E	A7 04		STAA 04, X
E770	07		TPA
E771	50		TSTB
E772	20 B3		BRA TESTZ
E774	86 08	MPY8	LDAA 008
E776	36		PSHA
E777	4F		CLRA
E778	30		TSX
E779	E6 06		LDAB 06, X
E778	56		RORB
E77C	24 02	MPYLP	BCC MPYSHT
E77E	AB 07		ADDA 07, X
E780	46	MPYSHT	RORA
E781	56		RORB
E782	6A 00		DEC 00, X
E784	26 F6		BNE MPYLP
E786	31		INS
E787	39		RTS
E788	FF		FCB 0FFH
E789	05		FCB 05
E78A	FF		FCB 0FFH
E78B	1F		FCB 1FH
E78C	FF		FCB 0FFH
E78D	38		FCB 38H
E78E	FF		FCB 0FFH
E78F	40		FCB 40H
E790	FF		FCB 0FFH
E791	48		FCB 48H
E792	FF		FCB 0FFH
E793	51		FCB 51H
E794	FF		FCB 0FFH
E795	66		FCB 66H
E796	FF		FCB 0FFH
E797	7A		FCB 7AH
E798	FF		FCB 0FFH

E799	7F		FCB 7FH
E79A	FF		FCB 0FFH
E79B	94		FCB 94H
E79C	FF		FCB 0FFH
E79D	99		FCB 99H
E79E	FF		FCB 0FFH
E79F	9C		FCB 9CH
E7A0	FF		FCB 0FFH
E7A1	A1		FCB 0A1H
E7A2	FF		FCB 0FFH
E7A3	AC		FCB 0ACH
E7A4	FF		FCB 0FFH
E7A5	B8		FCB 0B8H
E7A6	00		FCB 00
E7A7	17		FCB 17H
E7A8	00		FCB 00
E7A9	10		FCB 10H
E7AA	00		FCB 00
E7AB	2F		FCB 2FH
E7AC	00		FCB 00
E7AD	4F		FCB 4FH
E7AE	00		FCB 00
E7AF	5D		FCB 5DH
E7B0	00		FCB 00
E7B1	86		FCB 86H
E7B2	00		FCB 00
E7B3	96		FCB 96H
E7B4	FF		FCB 0FFH
E7B5	AD		FCB 0ADH
E7B6	FF		FCB 0FFH
E7B7	B3		FCB 0B3H
E7B8	30		TSX
E7B9	EE 05		LDX 05, X
E7BA	8D 06		BSR PHEX
E7BB	30		TSX
E7BE	EE 05		LDX 05, X
E7C0	8D 01		BSR PHEX
E7C2	39		RTS
E7C3	A6 00	PHEX	LDA 00, X
E7C5	8D 29		BSR ASCII R
E7C7	36		PSHA
E7C8	A6 00		LDA 00, X
E7CA	8D 20		BSR ASCII L
E7CC	8D 0E		BSR PUTAX
E7CE	32		PULA
E7CF	8D 10		BSR PUTA
E7D1	30	PINCX	TSX
E7D2	6C 08		INC 08, X
E7D4	26 02		BNE PINXRTS
E7D6	6C 07		INC 07, X
E7D8	39	PINXRTS	RTS
E7D9	30		TSX

E7DA	A6 04		LDA 04,X
E7DC	FE BF F5	PUTAX	LDX ACIAI
E7DF	EE 00		LDX 00,X
E7E1	36	PUTA	PSHA
E7E2	A6 00	PUTRDY	LDA 00,X
E7E4	85 02		BITA 002
E7E6	27 FA		BEQ PUTRDY
E7E8	32		PULA
E7E9	A7 01		STAA 01,X
E7EB	39		RTS
E7EC	44	ASCII	LSRA
E7ED	44		LSRA
E7EE	44		LSRA
E7EF	44		LSRA
E7F0	84 0F	ASCII	ANDA 00FH
E7F2	88 30		ADDA 030H
E7F4	81 39		CHPA 039H
E7F6	23 02		BLS ASCRTS
E7F8	88 07		ADDA 007
E7FA	39	ASCRTS	RTS
E7FB	30	PNESH	TSX
E7FC	EE 05		LDX 05,X
E7FE	A6 00		LDA 00,X
E800	81 04		CHPA 004
E802	27 06		BEQ PMSRTS
E804	80 D6		BSR PUTAX
E806	80 C9		BSR PINCX
E808	20 F1		BRA PNESS
E80A	39	PMSRTS	RTS
E80C	30		TSX
E80E	EE 05		LDX 05,X
E810	8D 05		BSR ALPNUM
E811	07	SCARRY	TPA
E812	30	SETUS	TSX
E814	A7 02		STAA 02,X
E815	39		RTS
E817	A6 00	ALPNUM	LDA 00,X
E819	81 41		CHPA 041H
E81B	2D 0E		BLT ANNUM
E81D	81 5A		CHPA 05AH
E81F	2E 12		BGT ANNOTOK
E821	81 C7		CHPA 0C7H
E823	29 10		BVS ANRTS
E825	80 07		SUBA 007
E827	84 0F	ANOK	ANDA 00FH
E828	0D		SEC
E829	39		RTS
E82B	81 30	ANUM	CHPA 030H
E82D	2D 04		BLT ANNOTOK
E82F	81 39		CHPA 039H
E831	2F F4		BLE ANOK
	0C	ANNOTOK	CLC

E832	69	SEV
E833	39	ANRTS RTS
E834	20 9B	JPINCX BRA PINCX
E836	FE BF F5	LDX ACIAI
E839	EE 00	LDX 00,X
E83B	A6 00	INWAIT LDAA 00,X
E83D	47	ASRA
E83E	24 FB	BCC INWAIT
E840	A6 01	LDAA 01,X
E842	84 7F	ANDA #7FH
E844	30	TSX
E845	A7 04	STAA 04,X
E847	39	RTS
E848	30	TSX
E849	E6 03	LDAB 03,X
E84B	6F 04	CLR 04,X
E84D	6F 03	CLR 03,X
E84F	30	CONHB TSX
E850	EE 05	LDX 05,X
E852	8D C1	BSR ALPNUM
E854	25 09	BCS CONFND
E856	5A	DECB
E857	2F 04	BLE CONENDC
E859	8D D9	BSR JPINCX
E85B	20 F2	BRA CONHB
E85D	20 B1	CONENDC BRA SCARRY
E85F	30	CONFND TSX
E860	EE 05	LDX 05,X
E862	8D B1	BSR ALPNUM
E864	29 18	BVS CONNOGD
E866	37	PSHB
E867	C6 04	LDAB #04
E869	30	TSX
E86A	68 04	CONSLP ASL 04,X
E86C	69 05	ROL 05,X
E86E	5A	DECB
E86F	2E F9	BGT CONSLP
E871	AA 04	ORAA 04,X
E873	A7 04	STAA 04,X
E875	33	PULB
E876	8D BC	BSR JPINCX
E878	5A	DECB
E879	2E E4	BGT CONFND
E87B	0D	SEC
E87C	20 92	BRA SCARRY
E87E	07	CONNOGD TPA
E87F	4C	INCA
E880	20 8F	BRA SETUS

;
 ;
 ;
 ;

E882	4C	CTABLE	FCC 'L'
E883	E4 2E		FDB LOAD
E885	47		FCC 'O'
E886	E4 20		FDB GO
E888	50		FCC 'P'
E889	E5 2E		FDB PUNCH
E888	40		FCC 'H'
E88C	E6 39		FDB MOVE
E88E	53		FCC 'S'
E88F	E5 F4		FDB SH
E891	44		FCC 'D'
E892	E3 4C		FDB DISHEN
E894	52		FCC 'R'
E895	E2 C5		FDB PREGS
E897	45		FCC 'E'
E898	E3 E2		FDB EOF
E89A	43		FCC 'C'
E89B	BF 05		FDB COLD
E89D	57		FCC 'W'
E89E	BF 08		FDB WARM
E8A0	4F		FCC 'O'
E8A1	BF 08		FDB ODESSEY
E8A3	42	QBADR	FCB 42H
E8A4	41		FCB 41H
E8A5	44		FCB 44H
E8A6	20		FCB 20H
E8A7	41		FCB 41H
E8A8	44		FCB 44H
E8A9	52		FCB 52H
E8AA	04		FCB 04
E8AB	52	QRNGERR	FCB 52H
E8AC	41		FCB 41H
E8AD	4E		FCB 4EH
E8AE	47		FCB 47H
E8AF	45		FCB 45H
E8B0	20		FCB 20H
E8B1	45		FCB 45H
E8B2	52		FCB 52H
E8B3	52		FCB 52H
E8B4	04		FCB 04
E8B5	45	QEOF	FCB 45H
E8B6	4F		FCB 4FH
E8B7	46		FCB 46H
E8B8	04		FCB 04
E8B9	3F	QQUES	FCB 3FH
E8BA	3F		FCB 3FH
E8BB	3F		FCB 3FH
E8BC	3F		FCB 3FH
E8BD	04		FCB 04
E8BE	43	QCKSNER	FCB 43H
E8BF	4B		FCB 4BH
E8C0	53		FCB 53H

```

;
; INTERRUPT HANDLER FOR TIME CLOCK AND SONAR AT 10 HZ
; THIS SUBROUTINE IS CALLED BY HARDWARE INTERRUPT (IRQ) AND AS
; SUCH, ALL REGISTERS AND SYSTEM STATUS ARE PRESERVED ON THE STACK.
; ON ENTRY, THE PROCESSOR WILL SET THE INTERRUPT MASK. IT WILL
; CLEAR THE MASK ON EXIT AND RESTORE THE PROCESSOR REGISTERS/STATUS
; ON EXIT.
;

```

```

E904 8D E9 1E TICHAN JSR FEE ;GO CHECK OPTICAL SHAFT ENCODERS FIRST
E907 3B RTI
;

```

```

;
; INCMEM
E908 6C 00 INCMEM INC X ;Increment memory contents
E90A 26 04 BNE INRET ;If result not 0, return
E90C 09 INCMEM INX ;Advance memory pointer
E90D 5A DECB ;Decrement precision counter
E90E 26 F8 BNE INCMEM ;If counter <0, continue incrementing
E910 39 INRET RTS ;Return
;

```

```

;
; DCRMEM
E911 A6 00 DCRMEM LDA X ;Fetch byte from memory
E913 80 01 SUBA #01H ;Decrement the byte
E915 A7 00 STAA X ;Save byte in memory
E917 21 04 BCC DCRET ;If no borrow required, return
E919 09 DCRMEM DEX ;Advance memory pointer
E91A 5A DECB ;Decrement precision counter
E91B 26 F4 BNE DCRMEM ;If counter <0, continue decrementing
E91D 39 DCRET RTS ;Return
;

```

```

*****
*
*
* DATE: 8 OCT 84
* VERSION: 1.0
* NAME: FEE (AS IN THE NURSERY RHYME)
* FUNCTION: THIS INTERRUPT HANDLER UPDATES THE COUNTS
* IN PREDEFINED INCREMENTS (DEFAULT 1" (3FH)
* WHEN THE PTM REACHES ITS TIME-OUT (I.E.
* INCREMENT DISTANCE HAS BEEN MEASURED, THEN
* THE PTM AUTOMATICALLY RESETS THE COUNTER
* AND THIS ROUTINE INCREMENTS THE COUNT IN
* MEMORY
* THE FRONT WHEEL OSE MEASURES THE ANGULAR
* POSITION OF THE FRONT WHEEL AND NOT DISTANCE
* TRAVELED BY THE FRONT WHEEL.
*
*
* OUTPUTS: INCREMENTS THE FOLLOWING REGISTERS IN MEMORY:
* FWCOUNT
* RWCOUNT1, RWCOUNT2, RWMOD1, RWMOD2,
* LWCOUNT1, LWCOUNT2, LWMOD1, LWMOD2
*****

```

```

;
;
;
E91E B6 C0 31 FEE LDAA IO+PTMF+PTMSTAT ;GET FRONT WHEEL STATUS
E921 48 ASLA ;CHECK FRONT WHEEL IRQ FLAG
E922 25 0F BCS FRONTWHEEL ;CONTINUE IF TRUE INTERRUPT
E924 B6 C0 41 FIE LDAA IO+PTMR+PTMSTAT ;ELSE GET RIGHT WHEEL STATUS
E927 48 ASLA ;CHECK RIGHT WHEEL IRQ FLAG
E928 25 1E BCS RIGHTWHEEL ;CONTINUE IF TRUE INTERRUPT
E92A B6 C0 39 FOE LDAA IO+PTML+PTMSTAT ;ELSE GET LEFT WHEEL STATUS
E92D 48 ASLA ;CHECK LEFT WHEEL IRQ FLAG
E92E 25 37 BCS LEFTWHEEL ;CONTINUE IF TRUE INTERRUPT
E930 7E E9 C2 FUM JMP TICHANI ;DONE WITH OSE INTERRUPTS
;
; HEAR
; THE
; CHIRP
; OF
; SONAR
; ONE!
; (SO GO CHECK THE SONAR INTERRUPTS)
;
E933 47 FRONTWHEEL ASRA ;
E934 47 ASRA ;SEE IF COUNTER 1 GENERATED IRQ..
E935 24 06 BCC CHKFWC2 ;IF NOT THEN SERVICE COUNTER 2
E937 7A BE FB CHKFWC1 DEC FWCOUNT+1 ;WHEEL HAS TURNED CCM
E93A FE C0 32 LDX IO+PTMF+T.CNT1 ;CLEAR INTERRUPT
E93D 47 CHKFWC2 ASRA ;SEE IF COUNTER 2 GENERATED IRQ
E93E 24 06 BCC FWDONE ;IF NOT CHECK OTHER WHEELS
E940 7C BE FB INC FWCOUNT+1 ;WHEEL HAS TURNED CLOCKWISE
E943 FE C0 3A LDX IO+PTMF+T.CNT2 ;CLEAR INTERRUPT
E946 20 DC FWDONE BRA FIE ;GO CHECK OTHER WHEELS
;
E948 47 RIGHTWHEEL ASRA ;
E949 47 ASRA ;SEE IF COUNTER 1 GENERATED IRQ
E94A 24 0B BCC CHKRWC2 ;IF NOT THEN SERVICE COUNTER 2
E94C C6 02 CHKRWC1 LDAB #02 ;#BYTES IN RWCOUNT1 (SIZE)
E94E CE BE FA LDX #RWCOUNT1+1 ;SET POINTER TO RWCOUNT1 LSBYTE
E951 BD E9 0B JSR INCMEM ;WHEEL HAS MOVED FORWARD 1"
;THAT'S ONE SMALL STEP FOR MARRS-1
;ONE GIANT LEAP FOR ROBOT KIND!!
;CLEAR INTERRUPT
E954 FE C0 42 LDX IO+PTMR+T.CNT1 ;SEE IF COUNTER 2 GENERATED IRQ
E957 47 CHKRWC2 ASRA ;IF NOT CHECK OTHER WHEELS
E958 24 0B BCC RWDONE ;#BYTES IN RWCOUNT2 (SIZE)
E95A C6 02 LDAB #02 ;SET POINTER TO RWCOUNT2 LSBYTE
E95C CE BE FC LDX #RWCOUNT2+1 ;WHEEL HAS MOVED BACKWARDS
E95F BD E9 0B JSR INCMEM ;CLEAR INTERRUPT
E962 FE C0 4A LDX IO+PTMR+T.CNT2 ;GO CHECK OTHER WHEELS
E965 20 C3 RWDONE BRA FOE
;
E967 47 LEFTWHEEL ASRA ;

```

RIGHT WHEEL:

FORWARD MOTION

A CHANNEL (COUNTER 2) GATES B CHANNEL (COUNTER 1)

REVERSE MOTION

B CHANNEL (COUNTER 1) GATES A CHANNEL (COUNTER 2)

LEFT WHEEL:

FORWARD MOTION

B CHANNEL (COUNTER 2) GATES A CHANNEL (COUNTER 1)

REVERSE MOTION

A CHANNEL (COUNTER 1) GATES B CHANNEL (COUNTER 2)

FRONT WHEEL PTM KEEPS TRACK OF ABSOLUTE HEADING OF FRONT DRIVE WHEEL. WITH THE DRIVE WHEEL CENTERED, THE COUNT AT FWCOUNT+1 SHOULD BE \$49.

WITH THE FRONT DRIVE WHEEL MAX LEFT FWCOUNT+1 SHOULD BE \$FF.

WITH THE FRONT DRIVE WHEEL 90 DEGREES RIGHT OF CENTER, THE FWCOUNT+1 SHOULD BE \$94.

THIS IS ASSUMING THAT A DEFAULT VALUE OF \$03 IS USED AS AN INCREMENTAL VALUE ON THE FRONT WHEEL PTM ALSO KNOWN AS BCPTRF1 OR BCPTRF2

FRONT WHEEL:

CLOCKWISE MOTION

B CHANNEL (COUNTER 2) GATES A CHANNEL (COUNTER 1)

COUNTER-CLOCKWISE MOTION

A CHANNEL (COUNTER 1) GATES B CHANNEL (COUNTER 2)

E9C2 CE C0 00
E9C5 A6 49
E9C7 48
E9C8 25 03
E9CA 7E BE C7

TICHAN1 LDX #10 ;POINT TO I/O AREA
LDAA PIAAB+P.SRA,X ;GET PIA A STATUS
ASLA ;CHECK INTERRUPT FLAG OF PIA A
BCS TICHAN2 ;CONTINUE IF TRUE INTERRUPT
JMP MORETIC ;ELSE RETURN TO CALLER

E9CD EE 1A
E9CF FF BE E6
E9D2 B6 BE E7
E9D5 43

TICHAN2 LDX PTMAB+T.CNT1,X ;GET SONAR READING FROM CHANNEL A
STX TICTEMP0 ;SAVE IT
LDAA TICTEMP0+1 ;GET LOW 8 BITS
COMA ;DATA IS IN NEGATIVE 1'S COMPLEMENT
;SO WE MUST CONVERT IT TO BE POSITIVE
;THE DISTANCE MEASURED
;IS FROM THE CENTER OF THE ROBOT

E9D6 B7 BE C1

STAA SONARA

E9D9 CE C0 00

LDX #10 ;POINT TO I/O AREA

E9DC	EE 1C	LDX	PTMAB+T.CNT2,X	;GET SONAR READING FROM CHANNEL B
E9DE	FF BE E6	STX	TICTEMP0	;SAVE IT
E9E1	B6 BE E7	LDA	TICTEMP0+1	;GET LOW 8 BITS
E9E4	43	COMA		;DATA IS IN ONE'S COMPLEMENT ;SO WE MUST CONVERT IT TO BE POSITIVE ;THE DISTANCE MEASURED ;IS FROM THE CENTER OF THE ROBOT
E9E5	B7 BE C2	STAA	SONARB	
E9E8	CE C0 00	LDX	#10	;POINT TO I/O AREA
E9EB	EE 22	LDX	PTMCD+T.CNT1,X	;GET SONAR READING FROM CHANNEL C
E9ED	FF BE E6	STX	TICTEMP0	;SAVE IT
E9F0	B6 BE E7	LDA	TICTEMP0+1	;GET LOW 8 BITS
E9F3	43	COMA		;DATA IS IN ONE'S COMPLEMENT ;SO WE MUST CONVERT IT TO BE POSITIVE ;THE DISTANCE MEASURED ;IS FROM THE CENTER OF THE ROBOT
E9F4	B7 BE C3	STAA	SONARC	
E9F7	CE C0 00	LDX	#10	;POINT TO I/O AREA
E9FA	EE 24	LDX	PTMCD+T.CNT2,X	;GET SONAR READING FROM CHANNEL D
E9FC	FF BE E6	STX	TICTEMP0	;SAVE IT
E9FF	B6 BE E7	LDA	TICTEMP0+1	;GET LOW 8 BITS
EA02	43	COMA		;DATA IS IN ONE'S COMPLEMENT ;SO WE MUST CONVERT IT TO BE POSITIVE ;THE DISTANCE MEASURED ;IS FROM THE CENTER OF THE ROBOT
EA03	B7 BE C4	STAA	SONARD	
EA06	FE C0 2E	LDX	10+PTM+T.CNT3	;UPDATE TIME SINCE TIME ZERO
EA09	00	INX		
EA0A	FF BE D9	STX	TICTIME	;TIME FROM COUNTER IS IN ONE'S COMPLEMENT
EA0D	73 BE D9	COM	TICTIME	
EA10	73 BE DA	COM	TICTIME+1	
EA13	FE BE D9	LDX	TICTIME	
EA16	FF BE C5	STX	SONTIME	;UPDATE TIME OF LAST SONAR READING
EA19	CE C0 00	LDX	#10	;POINT TO IO AREA
EA1C	A6 48	LDA	PIAAB+PIAPA,X	;GET SONAR SELECTED FOR A CHANNEL
EA1E	B7 BE B0	STAA	SONARSLA	;TELL USER WHICH SONAR WAS SELECTED
EA21	A6 4A	LDA	PIAAB+PIAPB,X	;GET SONAR SELECTED FOR B CHANNEL
EA23	B7 BE BE	STAA	SONARSLB	;TELL USER WHICH SONAR WAS SELECTED
EA26	A6 50	LDA	PIACD+PIAPC,X	;GET SONAR SELECTED FOR C CHANNEL
EA28	B7 BE BF	STAA	SONARSLC	;TELL USER WHICH SONAR WAS SELECTED
EA2B	A6 52	LDA	PIACD+PIAPD,X	;GET SONAR SELECTED FOR D CHANNEL
EA2D	B7 BE C0	STAA	SONARSLD	;TELL USER WHICH SONAR WAS SELECTED
EA30	7D BE E1	TST	SONCHANGE	;SEE IF NEW SONARS ARE TO BE SELECTED
EA33	27 03	BEQ	TICHANG	
EA35	7E BE C7	JMP	MORETIC	
EA38	B6 BE E2	TICHANG LDA	SONNEXA	;GET NEXT SONAR SELECT BYTE FOR SONAR A
EA3B	A7 48	STAA	PIAAB+PIAPA,X	;WRITE IT OUT TO THE PIA
EA3D	B6 BE E3	LDA	SONNEXB	;GET NEXT SONAR SELECT BYTE FOR SONAR B
EA40	A7 4A	STAA	PIAAB+PIAPB,X	;WRITE IT OUT TO THE PIA

```
EA42 B6 BE E4
EA45 A7 50
EA47 B6 BE E3
EA4A A7 52
EA4C 86 55
EA4E B7 BE E1
EA51 7E BE C7
```

```
LDAA SONNEXC ;GET NEXT SONAR SELECT BYTE FOR SONAR C
STAA PIACD+PIAPC,X ;WRITE IT OUT TO THE PIA
LDAA SONNEXD ;GET NEXT SONAR SELECT BYTE FOR SONAR D
STAA PIACD+PIAPD,X ;WRITE IT OUT TO THE PIA
LDAA #055H
STAA SONCHANGE ;TELL USER SONAR SELECTS HAVE BEEN CHANGED
JMP MORETIC
```

```
SUBROUTINE: READSONAR
BUFFERS USER PROGRAM FROM INTERRUPT PROCESSING
OF SONAR DATA. SONAR SELECT-READING PAIRS IN
LOCATIONS SONDATSA THRU SONDATRD ARE PLACED THERE
BY THIS SUBROUTINE AND AS SUCH ARE GUARENTEED TO
REPRESENT VALID/CURRENT SONAR READINGS.
```

PLEASE TAKE NOTE !!!!!!!

SONAR DATA READINGS SHOULD BE OBTAINED BY USER PROGRAMS
BY CALLING THIS SUBROUTINE AND THEN CHECKING THE VALUES
STORED IN LOCATIONS SONDATSA THRU SONDATRD I.E.:

```
SONDATSA THIS IS THE SELECT BYTE FOR SONAR A
SONDATRA THIS IS THE READING FROM SONAR A
SONDATSB THIS IS THE SELECT BYTE FOR SONAR B
SONDATRB THIS IS THE READING FROM SONAR B
SONDATSC THIS IS THE SELECT BYTE FOR SONAR C
SONDATRC THIS IS THE READING FROM SONAR C
SONDATSD THIS IS THE SELECT BYTE FOR SONAR D
SONDATRD THIS IS THE READING FROM SONAR D
```

```
EA54 0F
EA55 36
EA56 B6 BE BD
EA59 B7 BE FF
EA5C B6 BE BE
```

```
READSONAR SEI ;MASK THE INTERRUPT SYSTEM
PSHA ;SAVE THE A REGISTER
LDAA SSLA ;GET SONAR SELECT BYTE A
STAA SONDATSA ;STORE SONAR SELECT BYTE A
LDAA SSLB ;GET SONAR SELECT BYTE B
```

EA5F	B7 BE F1	STAA	SONDATSB	;STORE SONAR SELECT BYTE B
EA62	B6 BE BF	LDA	SSLC	;GET SONAR SELECT BYTE C
EA65	B7 BE F3	STAA	SONDATSC	;STORE SONAR SELECT BYTE C
EA68	B6 BE C0	LDA	SSLD	;GET SONAR SELECT BYTE D
EA6B	B7 BE F5	STAA	SONDATSD	;STORE SONAR SELECT BYTE D
EA6E	B6 BE C1	LDA	SONARA	;GET SONAR READING FOR SONAR A
EA71	B7 BE F0	STAA	SONATRA	;STORE SONAR READING FOR SONAR A
EA74	B6 BE C2	LDA	SONARB	;GET SONAR READING FOR SONAR B
EA77	B7 BE F2	STAA	SONATRB	;STORE SONAR READING FOR SONAR B
EA7A	B6 BE C3	LDA	SONARC	;GET SONAR READING FOR SONAR C
EA7D	B7 BE F4	STAA	SONATRC	;STORE SONAR READING FOR SONAR C
EA80	B6 BE C4	LDA	SONARD	;GET SONAR READING FOR SONAR D
EA83	B7 BE F6	STAA	SONATRD	;STORE SONAR READING FOR SONAR D
EA86	7D BE EE	TST	INTMASK	;CHECK TO SEE IF OTHERS WANT INTERRUPTS MASKED
EA89	26 01	BNE	RDSONDONE	;DONE IF YES
EA8B	0E	CLI		;ELSE CLEAR INTERRUPT MASK
EA8C	32	RDSONDONE	PULA	;RESTORE A REGISTER
EA8D	39	RTS		;RETURN TO CALLER

```

;
;
; SUBROUTINE POS (PUSH ON STACK) IS REENTRANT BUT MAY NOT
; BE USED BY AN INTERRUPT ROUTINE SINCE THE SYSTEM TEMPORARY
; REGISTERS ARE USED.
; POS PUSHES N BYTES ONTO THE STACK. ON ENTRY, THE A REGISTER
; CONTAINS THE BYTE COUNT (N) AND THE X REGISTER POINTS TO THE
; FIRST BYTE TO BE PUSHED ON TO THE STACK. THE B AND C REGISTERS
; ARE CLOBBERED. ON RETURN, X = X + N + 1, A = N, SP = SP - (N + 1)
; BECAUSE THE STACK GROWS DOWNWARD! THE STACK POINTER MUST EVENTUALLY
; RETURN TO IT'S PREVIOUS VALUE OR OTHER SYSTEM PROGRAMS OR DATA WILL
; BE CLOBBERED BY THE DOWNWARD GROWING STACK!
;
;

```

EA8E	0F	POS	SEI	;MASK HARDWARE INTERRUPTS	
EA8F	B7 BF D5		STAA	TEMP0	;SAVE THE A REGISTER
EA92	FF BF D7		STX	TEMP1	;AND THE X REGISTER
EA95	30		TSX		;GET THE RETURN ADDRESS OF THE SUBROUTINE
					;CALLER
EA96	EE 00		LDX	0,X	
EA98	FF BF D9		STX	TEMP2	;SAVE THE RETURN ADDRESS
EA9B	FE BF D7		LDX	TEMP1	;POINT TO THE BYTES TO BE PUSHED ON THE STACK
EA9E	16		TAB		;BYTE COUNT IS NOW IN B REGISTER
EA9F	A6 00	LOOPPOS1	LDA	0,X	;LOOP HERE N TIMES
EAA1	36		PSHA		;PUSHING VALUES ONTO THE STACK
EAA2	08		INX		;POINT TO NEXT BYTE
EAA3	5A		DECB		;ONE LESS BYTE TO PUSH
EAA4	26 F9		BNE	LOOPPOS1	;IF B IS NOT ZERO, LOOP UNTIL DONE
EAA6	B6 BF DA		LDA	TEMP2+1	;ELSE PUSH RETURN ADDRESS
EAA9	36		PSHA		;ONTO THE STACK
EAAA	B6 BF D9		LDA	TEMP2	
EAAD	36		PSHA		

EAFB	27 02	BEQ	DINESZMEM	; IF YES THEN DONE
EAFD	20 C0	BRA	SIZELP1	; CONTINUE MEMORY SIZE LOOP
EAFF	09	DINESZMEM	DEX	
EB00	FF BE DF	STX	RAMSIZEN	; STORE ADDRESS OF LAST MEMORY LOCATION TESTED
EB03	B6 BE EE	LDA	INTMASK	; CHECK TO SEE IF MASK IS TO BE LEFT SET
EB06	20 01	BNE	DSZMEM2	; RETURN TO CALLER IF MASK IS TO BE LEFT SET
EB08	0E	CLI		; ELSE CLEAR MASK AND
EB09	39	DSZMEM2	RTS	; RETURN TO CALLER

SUBROUTINE: ROMLAYRAM OVERLAYS ROM TO RAM AND RETURNS
RAM TO TRUE RAM STATE OVER ENTIRE
PROCESSOR ADDRESS SPACE

EB0A	CE 00 00	ROMLAYRAM	LDX	#XZERO	; POINT TO LOW MEMORY
EB0D	FF BE DD		STX	RAMSIZEL	
EB10	CE A0 00		LDX	#0A000H	; LAST USER RAM + 1
EB13	FF BE DF		STX	RAMSIZEN	
EB16	B6 BE 95	ROMOVERRAM	LDA	CRPIAA	; ENABLE ROM TO RAM OVERLAY
EB19	8A 38		ORAA	#038H	
EB1B	B7 C0 49		STAA	IO+PIAAB+PIACRA	
EB1E	8D EA B8		JSR	SIZEMEM	; SIZE MEMORY AND OVERLAY ROM TO RAM
EB21	B6 BE 95		LDA	CRPIAA	; RESTORE PIA A TO PREVIOUS MODE
EB24	B7 C0 49		STAA	IO+PIAAB+PIACRA	; THIS DISABLES THE ROM TO RAM OVERLAY
EB27	CE 00 00		LDX	#XZERO	; POINT TO LOW MEMORY
EB2A	FF BE DD		STX	RAMSIZEL	
EB2D	CE C0 00		LDX	#10	; POINT TO LAST RAM + 1 (I/O AREA)
EB30	FF BE DF		STX	RAMSIZEN	
EB33	8D EA B8		JSR	SIZEMEM	; SIZE MEMORY AGAIN TO SHOW TRUE RAM
EB36	39		RTS		; RETURN TO CALLER

SUBROUTINE: INTPIAAB INITIALIZE PIA AB ACCORDING TO VALUES
STORED IN SYSTEM RAM (COPIES OF THE
CONTROL REGISTERS)

EB37	CE C0 48	INTPIAAB	LDX	#IO+PIAAB	; POINT TO PIA
EB3A	B6 BE 95		LDA	CRPIAA	; GET CONTROL WORD
EB3D	84 FB		ANDA	#0FBH	; ACCESS DATA DIRECTION REGISTER
EB3F	A7 01		STAA	P.CRA,X	
EB41	B6 BE 96		LDA	CRPIAB	
EB44	84 FB		ANDA	#0FBH	
EB46	A7 03		STAA	P.CRB,X	
EB48	CE FF FF		LDX	#0FFFH	; MAKE ALL PIA LINES OUTPUTS
EB4B	FF C0 48		STX	IO+PIAAB+P.DDA	
EB4E	FF C0 4A		STX	IO+PIAAB+P.DDB	
EB51	C0 C0 48		LDX	#IO+PIAAB	; POINT TO PIA
EB54	B6 BE 95		LDA	CRPIAA	; GET CONTROL WORD

```

EB57 8A 04      ORAA #04H      ;ACCESS PREIPHERAL REGISTER
EB59 A7 01      STAA P.CRA, X
EB5B B6 BE 96   LDAA CRPIAB
EB5E 8A 04      ORAA #04H
EB60 A7 03      STAA P.CRB, X
EB62 B6 BE B0   LDAA SONARSLA      ;SELECT A SONAR
EB65 A7 00      STAA P.PRA, X
EB67 B6 BE BE   LDAA SONARSLB      ;SELECT A SONAR
EB6A A7 02      STAA P.PRB, X
EB6C 39        RTS      ;RETURN TO CALLER

```

```

SUBROUTINE:  INTPIACD      INITIALIZE PIA CD ACCORDING TO VALUES
                        STORED IN SYSTEM RAM (COPIES OF THE
                        CONTROL REGISTERS)

```

```

INTPIACD LDX #IO+PIACD      ;POINT TO PIA
EB6D CE C0 50   LDAA CRPIAC      ;GET CONTROL WORD
EB70 B6 BE 97   ANDA #0FBH      ;ACCESS DATA DIRECTION REGISTER
EB73 84 FB      STAA P.CRC, X
EB75 A7 01      LDAA CRPIAD
EB77 B6 BE 98   ANDA #0FBH
EB7A 84 FB      STAA P.CRD, X
EB7C A7 03      LDX #0FFFFH      ;MAKE ALL PIA LINES OUTPUTS
EB7E CE FF FF   STX IO+PIACD+P.DOC
EB81 FF C0 50   STX IO+PIACD+P.DOD
EB84 FF C0 52   LDX #IO+PIACD      ;POINT TO PIA
EB87 CE C0 50   LDAA CRPIAC      ;GET CONTROL WORD
EB8A B6 BE 97   ORAA #04H      ;ACCESS PREIPHERAL REGISTER
EB8D 8A 04      STAA P.CRC, X
EB8F A7 01      LDAA CRPIAD
EB91 B6 BE 98   ORAA #04H
EB94 8A 04      STAA P.CRD, X
EB96 A7 03      LDAA SONARSLC      ;SELECT A SONAR
EB98 B6 BE BF   STAA P.PRC, X
EB9B A7 00      LDAA SONARSLD      ;SELECT A SONAR
EB9D B6 BE C0   STAA P.PROD, X
EBA0 A7 02      RTS      ;RETURN TO CALLER
EBA2 39

```

```

SUBROUTINE:  INTPTMAB      INITIALIZE PTM AB FROM VALUES STORED
                        IN SYSTEM RAM

```

```

INTPTMAB LDX #IO+PTMAB      ;POINT TO PTM AB
EBA3 CE C0 18   LDAA CRPTMAB2      ;GET CONTROL WORD FOR TIMER 2
EBA6 B6 BE 84   STAA PTMCR2, X
EBA9 A7 01      LDAA CRPTMAB3      ;GET CONTROL WORD FOR TIMER 3
EBAE B6 BE 85   STAA PTMCR3, X
EBAE A7 00      LDAA CRPTMAB2
EBB0 B6 BE 84   ORAA #01H      ;POINT TO CONTROL REGISTER 1
EBB3 8A 01

```



```

EC1D FF C0 2C      STX  IO+PTM+T.LATCH2
EC20 FE BE A9      LDX  BCPHM3      ;GET BINARY PRELOAD VALUE FOR TIMER/COUNTER
EC23 FF C0 2E      STX  IO+PTM+T.LATCH3
EC26 39            RTS           ;RETURN TO CALLER

```

```

SUBROUTINE:  INTPMF      INITIALIZE PTH F FROM VALUES STORED
                    IN SYSTEM RAM

```

```

INTPMF LDX  #IO+PTMF      ;POINT TO PTH F
EC27 CE C0 30      LDAA CRPTMF2      ;GET CONTROL WORD FOR TIMER 2
EC2A B6 BE 80      STAA PTHCR2,X
EC2D A7 01          LDAA CRPTMF3      ;GET CONTROL WORD FOR TIMER 3
EC2F B6 BE 8E      STAA PTHCR3,X
EC32 A7 00          LDAA CRPTMF2
EC34 B6 BE 80      ORAA #01H        ;POINT TO CONTROL REGISTER 1
EC37 8A 01          STAA PTHCR2,X
EC39 A7 01          LDAA CRPTMF1      ;GET CONTROL WORD FOR TIMER 1
EC3B B6 BE 8C      STAA PTHCR1,X
EC3E A7 04          LDX  BCPMF1      ;GET BINARY PRELOAD VALUE FOR TIMER/COUNTER
EC40 FE BE AB      STX  IO+PTMF+T.LATCH1
EC43 FF C0 32      LDX  BCPMF2      ;GET BINARY PRELOAD VALUE FOR TIMER/COUNTER
EC46 FE BE AD      STX  IO+PTMF+T.LATCH2
EC49 FF C0 34      LDX  BCPMF3      ;GET BINARY PRELOAD VALUE FOR TIMER/COUNTER
EC4C FE BE AF      STX  IO+PTMF+T.LATCH3
EC4F FF C0 36      RTS           ;RETURN TO CALLER
EC52 39

```

```

SUBROUTINE:  INPTML      INITIALIZE PTH L FROM VALUES STORED
                    IN SYSTEM RAM

```

```

INPTML LDX  #IO+PTML      ;POINT TO PTH L
EC53 CE C0 38      LDAA CRPTML2      ;GET CONTROL WORD FOR TIMER 2
EC56 B6 BE 90      STAA PTHCR2,X
EC59 A7 01          LDAA CRPTML3      ;GET CONTROL WORD FOR TIMER 3
EC5B B6 BE 91      STAA PTHCR3,X
EC5E A7 00          LDAA CRPTML2
EC60 B6 BE 90      ORAA #01H        ;POINT TO CONTROL REGISTER 1
EC63 8A 01          STAA PTHCR2,X
EC65 A7 01          LDAA CRPTML1      ;GET CONTROL WORD FOR TIMER 1
EC67 B6 BE 8F      STAA PTHCR1,X
EC6A A7 00          LDX  BCPML1      ;GET BINARY PRELOAD VALUE FOR TIMER/COUNTER
EC6C FE BE B1      STX  IO+PTML+T.LATCH1
EC6F FF C0 3A      LDX  BCPML2      ;GET BINARY PRELOAD VALUE FOR TIMER/COUNTER
EC72 FE BE B3      STX  IO+PTML+T.LATCH2
EC75 FF C0 3C      LDX  BCPML3      ;GET BINARY PRELOAD VALUE FOR TIMER/COUNTER
EC78 FE BE B5      STX  IO+PTML+T.LATCH3
EC7B FF C0 3E      RTS           ;RETURN TO CALLER
EC7E 39

```

```

;
;
; SUBROUTINE:   INTPTMR      INITIALIZE PTH R FROM VALUES STORED
;                                     IN SYSTEM RAM
;
INTPTMR LDX   #IO+PTMR      ;POINT TO PTH R
        LDAA  CRPTMR2      ;GET CONTROL WORD FOR TIMER 2
        STAA  PTHCR2,X
        LDAA  CRPTMR3      ;GET CONTROL WORD FOR TIMER 3
        STAA  PTHCR3,X
        LDAA  CRPTMR2
        ORAA  #0:H         ;POINT TO CONTROL REGISTER 1
        STAA  PTHCR2,X
        LDAA  CRPTMR1      ;GET CONTROL WORD FOR TIMER 1
        STAA  PTHCR1,X
        LDX   BCPTMR1      ;GET BINARY PRELOAD VALUE FOR TIMER/COUNTER
        STX   IO+PTMR+T.LATCH1
        LDX   BCPTMR2      ;GET BINARY PRELOAD VALUE FOR TIMER/COUNTER
        STX   IO+PTMR+T.LATCH2
        LDX   BCPTMR3      ;GET BINARY PRELOAD VALUE FOR TIMER/COUNTER
        STX   IO+PTMR+T.LATCH3
        RTS                ;RETURN TO CALLER

```

```

;
;
; SUBROUTINE:   INTACIAT    INITIALIZE ACIAT FROM VALUES STORED
;                                     IN SYSTEM RAM
;
INTACIAT LDX   #IO+ACIAT    ;POINT TO ACIA T
        LDAA  #003H
        STAA  ACIACR,X      ;RESET THE ACIA
        LDAA  CRACIAT       ;GET CONTROL WORD FOR ACIA T
        STAA  ACIACR,X
        LDAA  ACIARX,X      ;THROW AWAY ANY TRASH ON RECEIVE LINE
        RTS                ;RETURN TO CALLER

```

```

;
;
; SUBROUTINE:   INTACIAX    INITIALIZE ACIAX FROM VALUES STORED
;                                     IN SYSTEM RAM
;
INTACIAX LDX   #IO+ACIAX    ;POINT TO ACIA X
        LDAA  #003H
        STAA  ACIACR,X      ;RESET THE ACIA
        LDAA  CRACIAX       ;GET CONTROL WORD FOR ACIA X
        STAA  ACIACR,X
        LDAA  ACIARX,X      ;THROW AWAY ANY TRASH ON RECEIVE LINE
        RTS                ;RETURN TO CALLER

```

```

;
;
; SUBROUTINE:   INTACIAL    INITIALIZE ACIAL FROM VALUES STORED
;                                     IN SYSTEM RAM
;

```

```

;
ECC9 CE C0 10 INTACIAL LDX #10+ACIAL ;POINT TO ACIA L
ECCC 86 03 LDAA #003H
ECCE A7 00 STAA ACIACR,X ;RESET THE ACIA
ECD0 B6 BE 82 LDAA CRACIAL ;GET CONTROL WORD FOR ACIA L
ECD3 A7 00 STAA ACIACR,X
ECD5 A6 01 LDAA ACIARX,X ;THROW AWAY ANY TRASH ON RECEIVE LINE
ECD7 39 RTS ;RETURN TO CALLER
;
;
;

```

```

;
;
;
ECC8 BD EB 37 INITPIA JSR INTPIAAB
ECCB BD EB 6D JSR INTPIACC
ECDE 39 RTS
;
;
;

```

```

;
;
;
ECDF BD EB A3 INITPTM JSR INTPTMAB
ECE2 BD EB CF JSR INTPTMCD
ECE5 BD EB FB JSR INTPTMV
ECE8 BD EC 27 JSR INTPTMF
ECEB BD EC 53 JSR INTPTML
ECEE BD EC 7F JSR INTPTMR
ECF1 39 RTS
;
;
;

```

```

;
;
;
ECF2 BD EC AB INITACIA JSR INTACIAT
ECF5 BD EC BA JSR INTACIAX
ECF8 BD EC C9 JSR INTACIAL
ECFB 39 RTS
;
;
;

```

MAIN INITIALIZATION ROUTINE ON POWER UP

```

;
;
;
;
;
INIT SEI ;MASK INTERRUPTS
LDS #BOS ;INITIALIZE STACK POINTER FOR SYSTEM
CLRA
COMA
STAA INTMASK ;INTERRUPTS NOT ALLOWED UNTIL INITIALIZATION
CLR POWERUP ;AND POWER UP COMPLETE
LDX #ADR ;SET UP BLOCK MOVE
LDS #PREG ;(DESTINATION) TO INITIALIZE USER REGISTERS
STS 0,X ;AND SYSTEM VECTORS
LDS #BLOCK1 ;POINT TO START OF BLOCK DATA
STS 2,X
LDS #BLOCK2 ;END OF BLOCK
STS 4,X
LDS #BOS ;RESET STACK POINTER TO SYSTEM STACK
JSR MOVE1 ;DO BLOCK MOVE
LDX #ADR ;SET UP BLOCK MOVE

```

```

ED23 8E BE 00      LDS    #CRACIAT      ;(DESTINATION) IO INITIALIZATION PARAMETERS
ED26 AF 00        STS    0,X
ED28 8E F1 BC      LDS    #BLOCK2      ;POINT TO START OF BLOCK DATA
ED2B AF 02        STS    2,X
ED2D 8E F2 4A      LDS    #BLOCK3      ;END OF BLOCK
ED30 AF 04        STS    4,X
ED32 8E BE 7F      LDS    #BOS          ;RESET STACK POINTER TO SYSTEM STACK
ED35 BD E6 46      JSR    MOVE1         ;DO BLOCK MOVE
ED38 8E BE 7F      LDS    #BOS          ;RESET STACK POINTER TO SYSTEM STACK
ED3B BD EC D8      INIT2 JSR    INITPIA      ;INITIALIZE PIA'S
ED3E 8E BE 7F      LDS    #BOS          ;RESET STACK POINTER TO SYSTEM STACK
ED41 BD EC DF      JSR    INITPTM      ;INITIALIZE PTM'S
ED44 8E BE 7F      LDS    #BOS          ;RESET STACK POINTER TO SYSTEM STACK
ED47 BD EC F2      JSR    INITACIA     ;INITIALIZE ACIA'S
ED4A 8E BE 7F      LDS    #BOS          ;RESET STACK POINTER TO SYSTEM STACK
ED4D BD EB 0A      JSR    ROMLAYRAM    ;SIZE MEMORY AND OVERLAY ROM TO RAM
ED50 8E BE 7F      LDS    #BOS          ;RESET STACK POINTER TO SYSTEM STACK
ED53 C6 53        LDAB   #055H        ;POWER UP IS COMPLETE
ED55 F7 BE DC      STAB   POWERUP
ED58 7F BE EE      DONEPOWER CLR    INTMASK      ;NO INTERRUPT MASK REQUIRED NOW SO
ED5B 0E           CLI           ;CLEAR INTERRUPT MASK
ED5C 7E E1 EF      JMP    START        ;GO TO PROTO PORTION OF OPERATING SYSTEM

```

SUBROUTINE: SONPRINT

ON ENTRY THE A REGISTER HAS THE VALUE TO PRINT AS A NUMBER FROM 0 TO 25.5
THE X REGISTER POINTS TO THE ADDRESS WHERE 4 ASCII BYTES WILL BE PLACED AS A DECIMAL REPRESENTATION OF THE VALUE IN THE A REGISTER. ACTUAL PRINTING IS PERFORMED BY SOME OTHER ROUTINE.

```

ED5F FF BF 7E      SONPRINT STX    LSXTEMP      ;SAVE POINTER TO PRINT BUFFER
ED62 CE ED AB      LDX    #LOOKS*8      ;GET STARTING ADDRESS OF LOOKUP TABLE
ED65 FF BF 7C      STX    LKSONTMP      ;SAVE IT IN A WORKING TEMP REGISTER
ED68 48           ASLA           ;IF VALUE OF A REGISTER IS ABOVE 127
ED69 25 28        BCS    SPA128        ;ADD 512 TO LOOKUP POINTER ELSE
ED6B 48           SP1 ASLA           ;IF VALUE OF A REGISTER WAS ABOVE 64
ED6C 25 31        BCS    SPA64         ;ADD 256 TO LOOKUP POINTER ELSE
ED6E 5F           SP2 CLRB           ;ADD REMAINING VALUE OF A REGISTER TO
ED6F BB BF 7D      ADDA   LKSONTMP+1    ;LOOKUP POINTER
ED72 B7 BF 7D      STAA   LKSONTMP+1
ED75 F9 BF 7C      ADCB   LKSONTMP      ;LOOKUP POINTER NOW POINTS 4*A BYTES
ED78 F7 BF 7C      STAB   LKSONTMP      ;INTO THE LOOKUP TABLE
ED7B C6 04        LDAB   #04H          ;SET UP TO TRANSFER TO PRINT BUFFER
ED7D FE BF 7C      SP3 LDX    LKSONTMP    ;FOUR ASCII BYTES
ED80 A6 00        LDAA  0,X           ;GET A BYTE

```

ED82	00		INX		;POINT TO NEXT BYTE IN TABLE
ED83	FF BF 7C		STX	LKSONTMP	;SAVE TABLE POINTER
ED86	FE BF 7E		LDX	LSXTEMP	;GET PRINT BUFFER POINTER
ED89	A7 00		STAA	0,X	;PUT ASCII CHARACTER INTO PRINT BUFFER
ED8B	00		INX		;POINT TO NEXT POSITION OF PRINT BUFFER
ED8C	FF BF 7E		STX	LSXTEMP	;SAVE PRINT BUFFER POINTER
ED8F	5A		DECB		;ONE LESS BYTE TO GO
ED90	26 EB		BNE	SP3	;LOOP BACK IF NOT THRU WITH FOUR BYTES
ED92	39		RTS		;ELSE RETURN TO CALLER
ED93	36	SPA128	PSHA		;SAVE VALUE TO BE PRINTED
ED94	86 02		LDAA	#02H	;ADD 512 TO INDEX POINTING INTO THE PRINT TABLE
ED96	BB BF 7C		ADDA	LKSONTMP	
ED99	B7 BF 7C		STAA	LKSONTMP	;SAVE THE POINTER
ED9C	32		PULA		;RESTORE VALUE TO BE PRINTED
ED9D	20 CC		BRA	SPI	;CONTINUE FINDING INDEX INTO PRINT TABLE
ED9F	36	SPA64	PSHA		;SAVE VALUE TO BE PRINTED
EDA0	86 01		LDAA	#01H	;ADD 256 TO INDEX POINTING INTO THE PRINT TABLE
EDA2	BB BF 7C		ADDA	LKSONTMP	
EDA5	B7 BF 7C		STAA	LKSONTMP	
EDA8	32		PULA		;RESTORE VALUE TO BE PRINTED
EDA9	20 C3		BRA	SP2	;CONTINUE FINDING INDEX INTO PRINT TABLE
		:			
		:			
EDAB	20 30 20 20	LOOKSON	FCC	' 0 '	;SONAR HEX TO ASCII DECIMAL LOOKUP TABLE
EDAF	20 30 2E 31		FCC	' 0.1'	
EDB3	20 30 2E 32		FCC	' 0.2'	
EDB7	20 30 2E 33		FCC	' 0.3'	
EDB8	20 30 2E 34		FCC	' 0.4'	
EDBF	20 30 2E 35		FCC	' 0.5'	
EDC3	20 30 2E 36		FCC	' 0.6'	
EDC7	20 30 2E 37		FCC	' 0.7'	
EDCB	20 30 2E 38		FCC	' 0.8'	
EDCF	20 30 2E 39		FCC	' 0.9'	
EDD3	20 31 2E 30		FCC	' 1.0'	
EDD7	20 31 2E 31		FCC	' 1.1'	
EDDB	20 31 2E 32		FCC	' 1.2'	
EDDF	20 31 2E 33		FCC	' 1.3'	
EDE3	20 31 2E 34		FCC	' 1.4'	
EDE7	20 31 2E 35		FCC	' 1.5'	
EDEB	20 31 2E 36		FCC	' 1.6'	
EDEF	20 31 2E 37		FCC	' 1.7'	
EDF3	20 31 2E 38		FCC	' 1.8'	
EDF7	20 31 2E 39		FCC	' 1.9'	
EDFB	20 32 2E 30		FCC	' 2.0'	
EDFF	20 32 2E 31		FCC	' 2.1'	
EE03	20 32 2E 32		FCC	' 2.2'	
EE07	20 32 2E 33		FCC	' 2.3'	
EE0B	20 32 2E 34		FCC	' 2.4'	
EE0F	20 32 2E 35		FCC	' 2.5'	
EE13	20 32 2E 36		FCC	' 2.6'	
EE17	20 32 2E 37		FCC	' 2.7'	
EE1B	20 32 2E 38		FCC	' 2.8'	

EE1F	20 32 2E 39	FCC	' 2.9'
EE23	20 33 2E 30	FCC	' 3.0'
EE27	20 33 2E 31	FCC	' 3.1'
EE28	20 33 2E 32	FCC	' 3.2'
EE2F	20 33 2E 32	FCC	' 3.3'
EE33	20 33 2E 34	FCC	' 3.4'
EE37	20 33 2E 35	FCC	' 3.5'
EE38	20 33 2E 36	FCC	' 3.6'
EE3F	20 33 2E 37	FCC	' 3.7'
EE43	20 33 2E 38	FCC	' 3.8'
EE47	20 33 2E 39	FCC	' 3.9'
EE4B	20 34 2E 30	FCC	' 4.0'
EE4F	20 34 2E 31	FCC	' 4.1'
EE53	20 34 2E 32	FCC	' 4.2'
EE57	20 34 2E 33	FCC	' 4.3'
EE5B	20 34 2E 34	FCC	' 4.4'
EE5F	20 34 2E 35	FCC	' 4.5'
EE63	20 34 2E 36	FCC	' 4.6'
EE67	20 34 2E 37	FCC	' 4.7'
EE6B	20 34 2E 38	FCC	' 4.8'
EE6F	20 34 2E 39	FCC	' 4.9'
EE73	20 35 2E 30	FCC	' 5.0'
EE77	20 35 2E 31	FCC	' 5.1'
EE7B	20 35 2E 32	FCC	' 5.2'
EE7F	20 35 2E 33	FCC	' 5.3'
EE83	20 35 2E 34	FCC	' 5.4'
EE87	20 35 2E 35	FCC	' 5.5'
EE8B	20 35 2E 36	FCC	' 5.6'
EE8F	20 35 2E 37	FCC	' 5.7'
EE93	20 35 2E 38	FCC	' 5.8'
EE97	20 35 2E 39	FCC	' 5.9'
EE9B	20 36 2E 30	FCC	' 6.0'
EE9F	20 36 2E 31	FCC	' 6.1'
EEA3	20 36 2E 32	FCC	' 6.2'
EEA7	20 36 2E 33	FCC	' 6.3'
EEAB	20 36 2E 34	FCC	' 6.4'
EEAF	20 36 2E 35	FCC	' 6.5'
EEB3	20 36 2E 36	FCC	' 6.6'
EEB7	20 36 2E 37	FCC	' 6.7'
EEBB	20 36 2E 38	FCC	' 6.8'
EEBF	20 36 2E 39	FCC	' 6.9'
EEC3	20 37 2E 30	FCC	' 7.0'
EEC7	20 37 2E 31	FCC	' 7.1'
EECB	20 37 2E 32	FCC	' 7.2'
EECF	20 37 2E 33	FCC	' 7.3'
EED3	20 37 2E 34	FCC	' 7.4'
EED7	20 37 2E 35	FCC	' 7.5'
EEDB	20 37 2E 36	FCC	' 7.6'
EEDF	20 37 2E 37	FCC	' 7.7'
EEE3	20 37 2E 38	FCC	' 7.8'
EEE7	20 37 2E 39	FCC	' 7.9'
EEEB	20 38 2E 30	FCC	' 8.0'

EEEF	20	38	2E	31	FCC	' 8.1'
EEF3	20	38	2E	32	FCC	' 8.2'
EEF7	20	38	2E	33	FCC	' 8.3'
EEFB	20	38	2E	34	FCC	' 8.4'
EEFF	20	38	2E	35	FCC	' 8.5'
EF03	20	38	2E	36	FCC	' 8.6'
EF07	20	38	2E	37	FCC	' 8.7'
EF0B	20	38	2E	38	FCC	' 8.8'
EF0F	20	38	2E	39	FCC	' 8.9'
EF13	20	39	2E	30	FCC	' 9.0'
EF17	20	39	2E	31	FCC	' 9.1'
EF1B	20	39	2E	32	FCC	' 9.2'
EF1F	20	39	2E	33	FCC	' 9.3'
EF23	20	39	2E	34	FCC	' 9.4'
EF27	20	39	2E	35	FCC	' 9.5'
EF2B	20	39	2E	36	FCC	' 9.6'
EF2F	20	39	2E	37	FCC	' 9.7'
EF33	20	39	2E	38	FCC	' 9.8'
EF37	20	39	2E	39	FCC	' 9.9'
EF3B	31	30	2E	30	FCC	'10.0'
EF3F	31	30	2E	31	FCC	'10.1'
EF43	31	30	2E	32	FCC	'10.2'
EF47	31	30	2E	33	FCC	'10.3'
EF4B	31	30	2E	34	FCC	'10.4'
EF4F	31	30	2E	35	FCC	'10.5'
EF53	31	30	2E	36	FCC	'10.6'
EF57	31	30	2E	37	FCC	'10.7'
EF5B	31	30	2E	38	FCC	'10.8'
EF5F	31	30	2E	39	FCC	'10.9'
EF63	31	31	2E	30	FCC	'11.0'
EF67	31	31	2E	31	FCC	'11.1'
EF6B	31	31	2E	32	FCC	'11.2'
EF6F	31	31	2E	33	FCC	'11.3'
EF73	31	31	2E	34	FCC	'11.4'
EF77	31	31	2E	35	FCC	'11.5'
EF7B	31	31	2E	36	FCC	'11.6'
EF7F	31	31	2E	37	FCC	'11.7'
EF83	31	31	2E	38	FCC	'11.8'
EF87	31	31	2E	39	FCC	'11.9'
EF8B	31	32	2E	30	FCC	'12.0'
EF8F	31	32	2E	31	FCC	'12.1'
EF93	31	32	2E	32	FCC	'12.2'
EF97	31	32	2E	33	FCC	'12.3'
EF9B	31	32	2E	34	FCC	'12.4'
EF9F	31	32	2E	35	FCC	'12.5'
EFA3	31	32	2E	36	FCC	'12.6'
EFA7	31	32	2E	37	FCC	'12.7'
EFAB	31	32	2E	38	FCC	'12.8'
EFAF	31	32	2E	39	FCC	'12.9'
EFB3	31	33	2E	30	FCC	'13.0'
EFB7	31	33	2E	31	FCC	'13.1'
EFB8	31	33	2E	32	FCC	'13.2'

EFBF	31 33 2E 33	FCC	'13.3'
EFC3	31 33 2E 34	FCC	'13.4'
EFC7	31 33 2E 35	FCC	'13.5'
EFCB	31 33 2E 36	FCC	'13.6'
EFCF	31 33 2E 37	FCC	'13.7'
EFD3	31 33 2E 38	FCC	'13.8'
EFD7	31 33 2E 39	FCC	'13.9'
EFD8	31 34 2E 30	FCC	'14.0'
EFDf	31 34 2E 31	FCC	'14.1'
EFE3	31 34 2E 32	FCC	'14.2'
EFE7	31 34 2E 33	FCC	'14.3'
EFE8	31 34 2E 34	FCC	'14.4'
EFEF	31 34 2E 35	FCC	'14.5'
EFF3	31 34 2E 36	FCC	'14.6'
EFF7	31 34 2E 37	FCC	'14.7'
EFF8	31 34 2E 38	FCC	'14.8'
EFFf	31 34 2E 39	FCC	'14.9'
F003	31 35 2E 30	FCC	'15.0'
F007	31 35 2E 31	FCC	'15.1'
F008	31 35 2E 32	FCC	'15.2'
F00F	31 35 2E 33	FCC	'15.3'
F013	31 35 2E 34	FCC	'15.4'
F017	31 35 2E 35	FCC	'15.5'
F018	31 35 2E 36	FCC	'15.6'
F01F	31 35 2E 37	FCC	'15.7'
F023	31 35 2E 38	FCC	'15.8'
F027	31 35 2E 39	FCC	'15.9'
F028	31 36 2E 30	FCC	'16.0'
F02F	31 36 2E 31	FCC	'16.1'
F033	31 36 2E 32	FCC	'16.2'
F037	31 36 2E 33	FCC	'16.3'
F038	31 36 2E 34	FCC	'16.4'
F03F	31 36 2E 35	FCC	'16.5'
F043	31 36 2E 36	FCC	'16.6'
F047	31 36 2E 37	FCC	'16.7'
F048	31 36 2E 38	FCC	'16.8'
F04F	31 36 2E 39	FCC	'16.9'
F053	31 37 2E 30	FCC	'17.0'
F057	31 37 2E 31	FCC	'17.1'
F058	31 37 2E 32	FCC	'17.2'
F05F	31 37 2E 33	FCC	'17.3'
F063	31 37 2E 34	FCC	'17.4'
F067	31 37 2E 35	FCC	'17.5'
F068	31 37 2E 36	FCC	'17.6'
F06F	31 37 2E 37	FCC	'17.7'
F073	31 37 2E 38	FCC	'17.8'
F077	31 37 2E 39	FCC	'17.9'
F078	31 38 2E 30	FCC	'18.0'
F07F	31 38 2E 31	FCC	'18.1'
F083	31 38 2E 32	FCC	'18.2'
F087	31 38 2E 33	FCC	'18.3'
F088	31 38 2E 34	FCC	'18.4'

F06F	31 38 2E 35	FCC	'18.5'
F093	31 38 2E 36	FCC	'18.6'
F097	31 38 2E 37	FCC	'18.7'
F098	31 38 2E 38	FCC	'18.8'
F09F	31 38 2E 39	FCC	'18.9'
F0A3	31 39 2E 30	FCC	'19.0'
F0A7	31 39 2E 31	FCC	'19.1'
F0AB	31 39 2E 32	FCC	'19.2'
F0AF	31 39 2E 33	FCC	'19.3'
F0B3	31 39 2E 34	FCC	'19.4'
F0B7	31 39 2E 35	FCC	'19.5'
F0BB	31 39 2E 36	FCC	'19.6'
F0BF	31 39 2E 37	FCC	'19.7'
F0C3	31 37 2E 38	FCC	'19.8'
F0C7	31 39 2E 39	FCC	'19.9'
F0CB	32 30 2E 30	FCC	'20.0'
F0CF	32 30 2E 31	FCC	'20.1'
F0D3	32 30 2E 32	FCC	'20.2'
F0D7	32 30 2E 33	FCC	'20.3'
F0DB	32 30 2E 34	FCC	'20.4'
F0DF	32 30 2E 35	FCC	'20.5'
F0E3	32 30 2E 36	FCC	'20.6'
F0E7	32 30 2E 37	FCC	'20.7'
F0EB	32 30 2E 38	FCC	'20.8'
F0EF	32 30 2E 39	FCC	'20.9'
F0F3	32 31 2E 30	FCC	'21.0'
F0F7	32 31 2E 31	FCC	'21.1'
F0FB	32 31 2E 32	FCC	'21.2'
F0FF	32 31 2E 33	FCC	'21.3'
F103	32 31 2E 34	FCC	'21.4'
F107	32 31 2E 35	FCC	'21.5'
F10B	32 31 2E 36	FCC	'21.6'
F10F	32 31 2E 37	FCC	'21.7'
F113	32 31 2E 38	FCC	'21.8'
F117	32 31 2E 39	FCC	'21.9'
F11B	32 32 2E 30	FCC	'22.0'
F11F	32 32 2E 31	FCC	'22.1'
F123	32 32 2E 32	FCC	'22.2'
F127	32 32 2E 33	FCC	'22.3'
F12B	32 32 2E 34	FCC	'22.4'
F12F	32 32 2E 35	FCC	'22.5'
F133	32 32 2E 36	FCC	'22.6'
F137	32 32 2E 37	FCC	'22.7'
F13B	32 32 2E 38	FCC	'22.8'
F13F	32 32 2E 39	FCC	'22.9'
F143	32 33 2E 30	FCC	'23.0'
F147	32 33 2E 31	FCC	'23.1'
F14B	32 33 2E 32	FCC	'23.2'
F14F	32 33 2E 33	FCC	'23.3'
F153	32 33 2E 34	FCC	'23.4'
F157	32 33 2E 35	FCC	'23.5'
F15B	32 33 2E 36	FCC	'23.6'

F15F	32 33 2E 37	FCC	'23.7'
F163	32 33 2E 38	FCC	'23.8'
F167	32 33 2E 39	FCC	'23.9'
F16B	32 34 2E 36	FCC	'24.0'
F16F	32 34 2E 31	FCC	'24.1'
F173	32 34 2E 32	FCC	'24.2'
F177	32 34 2E 33	FCC	'24.3'
F17B	32 34 2E 34	FCC	'24.4'
F17F	32 34 2E 35	FCC	'24.5'
F183	32 34 2E 36	FCC	'24.6'
F187	32 34 2E 37	FCC	'24.7'
F18B	32 34 2E 38	FCC	'24.8'
F18F	32 34 2E 39	FCC	'24.9'
F193	32 35 2E 36	FCC	'25.0'
F197	32 35 2E 31	FCC	'25.1'
F19B	32 35 2E 32	FCC	'25.2'
F19F	32 35 2E 33	FCC	'25.3'
F1A3	32 35 2E 34	FCC	'25.4'
F1A7	32 35 2E 35	FCC	'25.5'

BLOCKS FOR INCLUSION WITH MARRS-1 OPERATING SYSTEM ROM

F1AB	E1 EF	BLOCK1	FDB START
F1AD	BE 00		FDB USRSTAK
F1AF	E2 A8		FDB SWI30
F1B1	E1 FB		FDB ACTAA
F1B3	7E		FCB 07EH
F1B4	E9 04		FDB TICHAN
F1B6	7E		FCB 07EH
F1B7	E2 93		FDB SWIHAN
F1B9	7E		FCB 07EH
F1BA	E1 FB		FDB BREAK

F1BC	15	BLOCK2	FCB 15H	; COPY OF CONTROL REGISTER BYTE FOR ACIAT
F1BD	15		FCB 15H	; COPY OF CONTROL REGISTER BYTE FOR ACIAX
F1BE	15		FCB 15H	; COPY OF CONTROL REGISTER BYTE FOR ACIAL

F1BF	00		FCB 0H	; COPY OF CONTROL REGISTER BYTE FOR PTMAB1
F1C0	00		FCB 0H	; COPY OF CONTROL REGISTER BYTE FOR PTMAB2
F1C1	00		FCB 080H	; COPY OF CONTROL REGISTER BYTE FOR PTMAB3
F1C2	00		FCB 0H	; COPY OF CONTROL REGISTER BYTE FOR PTMCD1
F1C3	00		FCB 0H	; COPY OF CONTROL REGISTER BYTE FOR PTMCD2
F1C4	00		FCB 0H	; COPY OF CONTROL REGISTER BYTE FOR PTMCD3
F1C5	00		FCB 080H	; COPY OF CONTROL REGISTER BYTE FOR PTMV1
F1C6	00		FCB 080H	; COPY OF CONTROL REGISTER BYTE FOR PTMV2
F1C7	00		FCB 0H	; COPY OF CONTROL REGISTER BYTE FOR PTMV3

F1C8	40	FCB 040H	; COPY OF CONTROL REGISTER BYTE FOR PTHF1
F1C9	40	FCB 040H	; COPY OF CONTROL REGISTER BYTE FOR PTHF2
F1CA	00	FCB 0H	; COPY OF CONTROL REGISTER BYTE FOR PTHF3
F1CB	40	FCB 040H	; COPY OF CONTROL REGISTER BYTE FOR PTHL1
F1CC	40	FCB 040H	; COPY OF CONTROL REGISTER BYTE FOR PTHL2
F1CD	00	FCB 0H	; COPY OF CONTROL REGISTER BYTE FOR PTHL3
F1CE	40	FCB 040H	; COPY OF CONTROL REGISTER BYTE FOR PTHR1
F1CF	40	FCB 040H	; COPY OF CONTROL REGISTER BYTE FOR PTHR2
F1D0	00	FCB 0H	; COPY OF CONTROL REGISTER BYTE FOR PTHR3
;			
F1D1	F5	FCB 0F5H	; COPY OF CONTROL REGISTER BYTE FOR PIAA
F1D2	04	FCB 04H	; COPY OF CONTROL REGISTER BYTE FOR PIAB
F1D3	04	FCB 04H	; COPY OF CONTROL REGISTER BYTE FOR PIAC
F1D4	04	FCB 04H	; COPY OF CONTROL REGISTER BYTE FOR PIAD
;			
F1D5	FF F6	FDB 0FFF6H	; BINARY COUNT PRELOAD FOR PTHA81
F1D7	FF F6	FDB 0FFF6H	; BINARY COUNT PRELOAD FOR PTHA82
F1D9	00 24	FDB 00024H	; BINARY COUNT PRELOAD FOR PTHA83
F1DB	FF F6	FDB 0FFF6H	; BINARY COUNT PRELOAD FOR PTHC01
F1DD	FF F6	FDB 0FFF6H	; BINARY COUNT PRELOAD FOR PTHC02
F1DF	FF FF	FDB 0FFFFH	; BINARY COUNT PRELOAD FOR PTHC03
F1E1	52 07	FDB 05207H	; BINARY COUNT PRELOAD FOR PTHV1
F1E3	52 07	FDB 05207H	; BINARY COUNT PRELOAD FOR PTHV2
F1E5	FF FF	FDB 0FFFFH	; BINARY COUNT PRELOAD FOR PTHV3
F1E7	00 03	FDB 00003H	; BINARY COUNT PRELOAD FOR PTHF1
F1E9	00 03	FDB 00003H	; BINARY COUNT PRELOAD FOR PTHF2
F1EB	FF FF	FDB 0FFFFH	; BINARY COUNT PRELOAD FOR PTHF3
F1ED	00 3F	FDB 0003FH	; BINARY COUNT PRELOAD FOR PTHL1
F1EF	00 3F	FDB 0003FH	; BINARY COUNT PRELOAD FOR PTHL2
F1F1	FF FF	FDB 0FFFFH	; BINARY COUNT PRELOAD FOR PTHL3
F1F3	00 3F	FDB 0003FH	; BINARY COUNT PRELOAD FOR PTHR1
F1F5	00 3F	FDB 0003FH	; BINARY COUNT PRELOAD FOR PTHR2
F1F7	FF FF	FDB 0FFFFH	; BINARY COUNT PRELOAD FOR PTHR3
;			
F1F9	01	FCB 01H	; SONAR SELECT BYTE WRITTEN TO PIA A
F1FA	01	FCB 01H	; SONAR SELECT BYTE WRITTEN TO PIA B
F1FB	01	FCB 01H	; SONAR SELECT BYTE WRITTEN TO PIA C
F1FC	01	FCB 01H	; SONAR SELECT BYTE WRITTEN TO PIA D
;			
F1FD	12	FCB 012H	; LAST SONAR A READING
F1FE	12	FCB 012H	; LAST SONAR B READING
F1FF	12	FCB 012H	; LAST SONAR C READING
F200	12	FCB 012H	; LAST SONAR D READING
;			
F201	00 00	FDB 0000H	; TIC TIME OF LAST SONAR READING
;			
F203	39	FCB 039H	; JUMP VECTOR FOR EXTENDED TIC INTERRUPT

```

;ROUTINE (PRESENTLY SET TO RTS)
F204 01 01      FDB 00101H
;
F206 00      FCB 000H
F207 00      FCB 000H
F208 00      FCB 000H
F209 00      FCB 000H
F20A 02      FCB 002H
F20B 0A      FCB 00AH
F20C 05      FCB 005H
F20D 04      FCB 004H
F20E 01      FCB 001H
F20F 02      FCB 002H
F210 01      FCB 001H
F211 04      FCB 004H
F212 08      FCB 008H
F213 09      FCB 009H
F214 01      FCB 001H
;
F215 00 00      FDB 00000H      ;ONE TENTH SECOND TIC TIME COUNT SINCE TIME ZERO
;
F217 48      FCB 048H      ;OFFSET INTO I/O AREA FOR PORT INITIALIZATION
;
F218 00      FCB 000H      ;POWERUP NOT COMPLETE
;
F219 00 00      FDB 00000H      ;START OF RAM
F21B 08 00      FDB 10      ;END OF RAM + 1 (I/O AREA)
F21D 55      FCB 055H      ;CHANGE SELECTED SONARS IF 00 ELSE INTERRUPT
;HANDLER SETS THIS BYTE TO 055H
F21E 01      FCB 001H      ;NEXT SONAR SELECT BYTE WRITTEN TO PIA A
F21F 01      FCB 001H      ;NEXT SONAR SELECT BYTE WRITTEN TO PIA B
F220 01      FCB 001H      ;NEXT SONAR SELECT BYTE WRITTEN TO PIA C
F221 01      FCB 001H      ;NEXT SONAR SELECT BYTE WRITTEN TO PIA D
F222 00 00      FDB 0      ;TICTEMP0 TEMPORARY REGISTER FOR TIC INTERRUPT
F224 00 00      FDB 0      ;TICTEMP1 TEMPORARY REGISTER FOR TIC INTERRUPT
F226 00 00      FDB 0      ;TICTEMP2 TEMPORARY REGISTER FOR TIC INTERRUPT
F228 00 00      FDB 0      ;TICTEMP3 TEMPORARY REGISTER FOR TIC INTERRUPT
F22A FF      FCB 0FFH      ;INTMASK INTERRUPTS MASKED IF 4FF ELSE NOT MASKED IF 000
F22B 00      FCB 0      ;SONDATSA SONAR SELECT BYTE FROM READSONAR ROUTINE
F22C 00      FCB 0      ;SONDATRA SONAR READING FROM READSONAR ROUTINE
F22D 00      FCB 0      ;SONDATSB SONAR SELECT BYTE FROM READSONAR ROUTINE
F22E 00      FCB 0      ;SONDATRB SONAR READING FROM READSONAR ROUTINE
F22F 00      FCB 0      ;SONDATSC SONAR SELECT BYTE FROM READSONAR ROUTINE
F230 00      FCB 0      ;SONDATRC SONAR READING FROM READSONAR ROUTINE
F231 00      FCB 0      ;SONDATSD SONAR SELECT BYTE FROM READSONAR ROUTINE
F232 00      FCB 0      ;SONDATRD SONAR READING FROM READSONAR ROUTINE
F233 00 49      FDB 0049H      ;FWCOUNT FRONT WHEEL ABSOLUTE COUNT FOR STRAIGHT AHEAD
F235 00 00      FDB 0      ;RWCOUNT1 RIGHT WHEEL PTM COUNTER 1 COUNTS
F237 00 00      FDB 0      ;RWCOUNT2 RIGHT WHEEL PTM COUNTER 2 COUNTS
F239 00 00      FDB 0      ;LMCOUNT1 LEFT WHEEL PTM COUNTER 1 COUNTS
F23B 00 00      FDB 0      ;LMCOUNT2 LEFT WHEEL PTM COUNTER 2 COUNTS
F23D 00 00      FDB 0      ;RWMOD1 RIGHT WHEEL PTM 1 MODULO COUNT

```

```

F23E 00          FCB 0          ;RWM002 RIGHT WHEEL PTH 2 MODULO COUNT
F23F 00          FCB 0          ;LWM001 LEFT WHEEL PTH 1 MODULO COUNT
F240 00          FCB 0          ;LWM002 LEFT WHEEL PTH 2 MODULO COUNT
F241 7E          FCB 07EH
F242 01 00       FDB 00100H ;JUMP VECTOR FOR C (COLD START) COMMAND
F244 7E          FCB 07EH
F245 01 03       FDB 00103H ;JUMP VECTOR FOR W (WARM START) COMMAND
F247 7E          FCB 07EH
F248 20 01       FDB 02001H ;JUMP VECTOR FOR O (ODESSEY) COMMAND
F24A 01          NOP          ;MARK END OF BLOCK 2

```

```

BLOCK3
;
;
;
;

```

```

FF00          ORG 0FF00H          ;MARRS-1 SYSTEM CREDIT AREA
FF00 40 41 52 52 FCC 'MARRS-1 CREATORS'

```

```

FF04 53 2D 31 20
FF08 43 52 45 41
FF0C 54 4F 52 53
FF10 31 4C 54 20
FF14 52 41 4E 44
FF18 41 4C 4C 20
FF1C 4F 57 45 4E
FF20 43 41 50 54
FF24 20 20 20 20
FF28 20 20 20 20
FF2C 20 20 20 20
FF30 20 20 42 45
FF34 52 54 20 20
FF38 20 20 20 20
FF3C 20 20 20 20
FF40 20 20 20 20
FF44 53 43 48 4E
FF48 45 49 44 45
FF4C 52 20 20 20
FF50 31 4C 54 20
FF54 54 4F 4D 20
FF58 43 4C 49 46
FF5C 46 4F 52 44

```

```

FCC 'ILT RANDALL OWEN'

```

```

FCC 'CAPT '

```

```

FCC ' BERT '

```

```

FCC ' SCHNEIDER '

```

```

FCC 'ILT TOM CLIFFORD'

```

```

FFF3          ORG 0FFF3H          ;RESET VECTOR AREA
FFF3 7E EC FC   LASTCH JMP INIT          ;LAST CHANCE FOR RECOVERY
FFF8 BF F7     SYSIRQ FDB IRQVEC        ; * FOR MASKABLE INTERRUPT REQUEST
FFFA BF FA     SYSSMI FDB SMIVEC        ; * FOR SOFTWARE INTERRUPT REQUEST
FFFC BF FD     SYSNMI FDB NMIVEC        ; * FOR NONMASKABLE IRQ
FFFE EC FC     RESETV FDB INIT          ; * FOR MASTER AND POWER ON RESET
;
;
;
;

```

```

;*****
;

```

```

0000          end          ;THAT'S ALL FOLKS

```

No error(s).

SYMBOL TABLE FOR FILE NAVRON.A

A.C	0000	A.L	0010	A.RX	0001	A.S	0000
A.T	0000	A.TX	0001	A.X	0008	40	0001
A1	0002	A2	0004	A3	0008	A4	0010
A5	0020	A6	0040	A7	0060	ABORT	E287
ACIAA	E1FB	ACIACR	0060	ACIAI	BFF5	ACIAL	0010
ACIARI	0001	ACIASTAT	0000	ACIAT	0000	ACIATX	0001
ACIAX	0008	ADDAB	E71C	ADDABX1	E718	ADDH	BFCE
ADDL	BFCC	ADDRS	E635	ADDZ	E731	ADR	BFCA
ALPHUM	E815	ANNOTOK	E831	ANNUM	E829	ANOK	E825
ANRTS	E833	AREG	BFEC	ASCIIIL	E7EC	ASCIIIR	E7F0
ASCRTS	E7FA	B0	0001	B1	0002	B2	0004
B3	0008	B4	0010	B5	0020	B6	0040
B7	0080	BADSZMEM	EAE4	BADTAP	E4C1	BCPTMAB1	BE99
BCPTMAB2	BE98	BCPTMAB3	BE9D	BCPTMCD1	BE9F	BCPTMCD2	BEA1
BCPTMCD3	BEA3	BCPTMF1	BEAB	BCPTMF2	BEAD	BCPTMF3	BEAF
BCPTML1	BEB1	BCPTML2	BEB3	BCPTML3	BEB5	BCPTMR1	BEB7
BCPTMR2	BEB9	BCPTMR3	BEB8	BCPTMV1	BEA5	BCPTMV2	BEA7
BCPTMV3	BEA9	BLOCK1	F1AB	BLOCK2	F1BC	BLOCK3	F24A
BOS	BE7F	BREAK	E1F8	BREAK1	E291	BREG	BFEB
BU-	BF80	BUFEND	BFC7	BUFPTR	BF00	BYTENM1	E376
BYTENUM	E36A	C0	0001	C1	0002	C2	0004
C3	0008	C4	0010	C5	0020	C6	0040
C7	0080	CHEKSH	E301	CHKFWC1	E937	CHKFWC2	E930
CHKLWC1	E968	CHKLWC2	E976	CHKRWC1	E94C	CHKRWC2	E957
CKSUM	BFD4	COLD	BF05	CONENDC	F550	CONFND	E85F
CONHB	E84F	CONNOGD	E87E	CONSLP	E86A	CONV4	E329
COUNT	BFD3	CPRET	E34B	CPRMEM	E338	CRACIAL	BE82
CRACIAT	BE80	CRACIAX	BE81	CREG	BFEA	CRPIAA	BE95
CRPIAB	BE96	CRPIAC	BE97	CRPIAD	BE98	CRPTMAB1	BE83
CRPTMAB2	BE84	CRPTMAB3	BE85	CRPTMCD1	BE86	CRPTMCD2	BE87
CRPTMCD3	BE88	CRPTMF1	BE8C	CRPTMF2	BE8D	CRPTMF3	BE8E
CRPTML1	BE8F	CRPTML2	BE90	CRPTML3	BE91	CRPTMR1	BE92
CRPTMR2	BE93	CRPTMR3	BE94	CRPTMV1	BE89	CRPTMV2	BE8A
CRPTMV3	BE8B	CS1	E30E	CTABLE	E882	D0	0001
D1	0002	D2	0004	D3	0008	D4	0010
D5	0020	D6	0040	D7	0080	DCRET	E91D
DCRMEM	E911	DISHEM	E34C	DISHEM1	E354	DL10	E27D
DLOOP	E275	DNSZMEM	EAF7	DONEPOMU	ED58	DSZMEM2	EB09
ECHO	BFE8	ENDDM	E3E1	EOF	E3E2	EOF1	E3E7
FEE	E91E	FIE	E924	FINDS	E4C3	FOE	E92A
FRONTMHE	E933	FS10	E4C4	FSTSZGD	EAF1	FUM	E930
FWCOUNT	BEF7	FWDONE	E946	FWRESET	E9A4	GETRG1	E401
GETRG3	E407	GETRG4	E41B	GETRNG	E3F0	GO	E420
GO10	E42B	INCMEM	E908	INIT	ECFC	INIT2	ED38
INITACIA	ECF2	INITPIA	ECD8	INITPTH	ECDF	INK	E627
INLOOP1	E398	INLOOP2	E3A8	INRET	E910	INTACIAL	ECC9
INTACIAT	ECAB	INTACTAX	ECBA	INTMASK	BEEE	INTPIAAB	EB37
INTPIACD	EB6D	INTPTMAB	EBA3	INTPTMCD	EBCF	INTPTMF	EC27
INTPTML	ECS3	INTPTR	EC7F	INTPTHV	EBFB	INWAIT	E838

IO	C000	IOFFSET	BEDB	IROVEC	BFF7	ISCTRLX	E325
JBAD	E636	JPINCX	E834	LASTCH	FFF5	LDR10	E498
LEFTWEE	E967	LHF4	E44F	LHF9	E483	LKSONTHP	BF7C
LOAD	E42E	LOAD1	E463	LOAD2	E433	LOCVV	E664
LODFST	E43C	LOOKSON	EDAB	LOOPPOS1	EA9F	LSXTEMP	BF7E
LWCOUNT1	BEFD	LWCOUNT2	BEFF	LWDONE	E984	LWMOD1	BF03
LWMOD2	BF04	LWRESET	E985	MA	E6E8	MACIA	0000
MACIA1	BFF5	MBADDR	E047	MBEGA	A002	MBYTE	E053
MBYTECT	A008	MC1	E044	MC2	E132	MCHANGE	E085
MCHASI	E087	MCKSN	A00A	MCONTL2	E0FF	MCONTRL	E0E3
MENDA	A004	MENDAI	A005	MINIHC	E0BE	MINCH	E078
MINEEE	E1AC	MINHEX	E0AA	MINDEK1	E1BA	MINDEK2	E188
MINDEK0	E1B1	MIO	E000	MIOS	E1EA	MIOV	A000
MLOAD	E00A	MLOAD11	E02F	MLOAD15	E038	MLOAD19	E040
MLOAD3	E013	MMCL	E19D	MMCLOFF	E19C	MMCONT	A011
MNTAPE1	E134	MNIO	A006	MMONENT	E242	MMONITR	E243
MORETIC	BEC7	MOUT2H	E0BF	MOUT2HS	E0CA	MOUT4HS	E0C8
MOUTCH	E075	MOUTEEE	E1D1	MOUTH	E067	MOUTH	E068
MOUTS	E0CC	MOUTS2	E0CE	MOVE	E639	MOVE1	E646
MOVE2	E63E	MPDATA1	E07E	MPDATA2	E07B	MPDOWN	E005
MPRINT	E11F	MPUN11	E148	MPUN22	E15A	MPUN23	E15C
MPUN32	E17C	MPUNCH	E13D	MPY8	E774	MPYLP	E77C
MPYSHT	E780	MSAV	E1A5	MSFE	E113	MSFE1	E11D
MIGNON	E28A	MSP	A008	MSTACK	A042	MTEMP	A00E
MTW	A00F	MTW1	A010	MXHI	A00C	MXLOW	A00D
MXTEMP	A012	MYFLAG0	BFE5	MYFLAG1	BFE6	NAI	E4F2
NA3	E506	NEX2D	E4CC	NHIVEC	BFFD	NSSLA	BEE2
NSSLB	BEE3	NSSLC	BEE4	NSSLD	BEE5	NXTADR	E4E6
NXTRTS	E4F1	OC10	E51C	OC20	E528	ODESSEY	BF0B
OFFSET	BFC8	OSEMOD	BF01	OSEREG	BEF7	OSRAM	BE00
OUTCH	E508	OUTCHX	E509	OUTLOOP	E386	P.AB	0048
P.CD	0050	P.CRA	0001	P.CRB	0003	P.CRC	0001
P.CRD	0003	P.DOA	0000	P.DOB	0002	P.DOC	0000
P.DOD	0002	P.PRA	0000	P.PRB	0002	P.PRC	0000
P.PRD	0002	P.SRA	0001	P.SRB	0003	P.SRC	0001
P.SRD	0003	P4HEXS	ESA5	PBADR	E5ED	PC	E6A0
PCRLF	E52A	PERIOD	E3B4	PEXISTS	E5AC	PHEX	E7C3
PHF20	E546	PIAAB	0048	PIACD	0050	PIACRA	0001
PIACRB	0003	PIACRC	0001	PIACRD	0003	PIADDA	0000
PIADDB	0002	PIADDC	0000	PIADDD	0002	PIAPA	0000
PIAPB	0002	PIAPC	0000	PIAPD	0002	PIASTATA	0001
PIASTATB	0003	PIASTATC	0001	PIASTATD	0003	PINCX	E7D1
PINXRTS	E7D8	PMESS	E7FB	PMSRTS	E80A	POS	E88E
POSDONE	E8B7	POWERUP	BEDC	PRI	E2CA	PRI0	E2DA
PR20	E2E4	PREC10	E585	PREG	BFEF	PREGS	E2C5
PRELPTHF	E986	PRELPTML	E99A	PRELPTH	E990	PRNTASC	E3B6
PS	E675	PSPACE	ESA7	PTNAB	0018	PTMCD	0020
PTMCR1	0000	PTMCR2	0001	PTMCR3	0000	PTHF	0030
PTML	0038	PTNR	0040	PTNSTAT	0001	PTHV	0028
PULXA	E705	PUNBYTE	E59D	PUNCH	E52E	PUNCH1	E533
PUND10	E558	PUND20	E55A	PUNT2	E197	PUTA	E7E1
PUTAX	E7DC	PUTRDY	E7E2	PX2	E58C	PXISTX	E5AF

Q6SPACE	E8E4	QBADR	E8A3	QOKSMER	E88E	QEOF	E8B5
QQUES	E889	QREGNAM	E8EB	QRNGERR	E8AB	QSI	E808
QTAPER	E8C7	QTPEOF	E8D0	RAMSIZEN	BEDF	RAMSIZEL	BED0
RDPRE	E464	RDSORDON	E89C	READAC1	E319	READSONA	EAS4
RECTYP	BFD2	RESETV	FFFE	RESTAK	E2F1	RET39	E328
RIGHTWHE	E948	RNGERR	E414	ROMLAYRA	E80A	ROMOVERR	EB16
ROZR2P2	E334	RS	E686	RSRSR	E65A	RSRXIT	E68C
RT10	E25A	RT20	E261	RT90	E267	RUS10	E2F7
RWCOUNT1	BEF9	RWCOUNT2	BEFB	RWDONE	E965	RWMOD1	BF01
RWMOD2	BF02	RWRESET	E9A8	SCARRY	E810	SETH1	ESF3
SETHM	ESDF	SETOFF	E5C2	SETOUT	E5D7	SETPUL	ESDE
SETUS	E811	SIZELP1	EABF	SIZEMH	EAB8	SH	ESF4
SM10	ESFD	SM30	E60E	SONARA	BEC1	SONARB	BEC2
SONARC	BEC3	SONARD	BEC4	SONARSLA	BEB0	SONARSLB	BEBE
SONARSLC	BEFB	SONARSLD	BEC0	SONCHANG	BEE1	SONDATRA	BEF0
SONDATRB	BEF2	SONDATRC	BEF4	SONDATRO	BEF6	SONDATSA	BEFF
SONDATSB	BEF1	SONDATSC	BEF3	SONDATSO	BEF5	SONNEXA	BEE2
SONNEXB	BEE3	SONNEXC	BEE4	SONNEXD	BEE5	SONPRINT	ED5F
SONTIME	BEC5	SP1	ED6B	SP2	ED6E	SP3	ED70
SPA128	ED93	SPA64	ED9F	SREG	BFF1	SSLA	BEBD
SSLB	BEBE	SSLC	BEBF	SSLD	BEC0	STAB	E6C9
START	E1EF	START1	E1FD	STAXH	F722	SUBABX1	E742
SW120	E2A3	SW130	E2A8	SW140	E2AF	SW150	E2B2
SWIHAK	E295	SWIVEC	BFFA	SYSFLAG	BFE7	SYSIRQ	FFF8
SYSSMI	FFFC	SYSSMI	FFFA	T.AB	0018	T.C1	0000
T.C2	0001	T.C3	0000	T.CD	0020	T.CNT1	0002
T.CNT2	0004	T.CNT3	0006	T.F	0030	T.L	0038
T.LATCH1	0002	T.LATCH2	0004	T.LATCH3	0006	T.R	0040
T.S	0001	T.V	0028	TA	E728	TABX1	E6CF
TCOUNT	BFE9	TEMP0	BFD5	TEMP1	BFD7	TEMP2	BFD9
TEMP3	BFD8	TEMP4	3FD0	TEMP5	BFD7	TEMP6	BFE1
TEMP7	BFE3	TESTZ	E727	TICHAN	E904	TICHAN1	E9C2
TICHAN2	E9CD	TICHAN3	EA38	TICTEMP0	BEE6	TICTEMP1	BEE8
TICTEMP2	BEEA	TICTEMP3	BEEC	TICTIME	BED9	TIMEZERO	BECA
TRC	E6AC	TSUB	E751	TUSRAM	BC00	USRSTAK	BE00
USW1	BFF3	W20	E61A	W30	E626	WATTY	E611
WARN	BF08	XABX1	E6D9	XREG	BFFD	XZERO	0000

 *
 * APPENDIX B *
 *

FILE: XTEND.A
 EXTENDED INTERRUPT HANDLER AS OF 20 OCT 1984

```

BC00      TUSRAM      EQU      0BC00H      ;TOP OF USER RAM
ECFC      INIT       EQU      0ECFCH      ;SYSTEM INITIALIZATION ENTRY POINT
0000      XZERO      EQU      00000H      ;LOAD ZERO INTO INDEX REGISTER
C000      IO         EQU      0C000H      ;IO AREA
0000      ACIAT      EQU      0         ;TERMINAL ACIA OFFSET INTO IO AREA
0000      A.S        EQU      0         ;ACIA STATUS OFFSET
0000      A.C        EQU      0         ;ACIA CONTROL OFFSET
0001      A.TX       EQU      1         ;ACIA TRANSMIT REGISTER OFFSET
0001      A.RX       EQU      1         ;ACIA RECEIVE REGISTER OFFSET
BEEE      INTMASK    EQU      0BEEEH     ;INTERRUPT MASK 0=NO 1FF=YES
EA54      READSONAR  EQU      0EA54H     ;READ SONAR SUBROUTINE
BEE1      SONCHANGE  EQU      0BEE1H     ;CHANGE SONARS IF=0 ELSE NO=155
BFB       INTPTRV   EQU      0BFBH
0011      XON        EQU      011H
0013      XOFF       EQU      013H
BEC7      MORETIC    EQU      0BEC7H     ;JUMP VECTOR FOR EXTENDED INTERRUPTS
BED9      TICTIME    EQU      0BED9H     ;TIME SINCE TIME ZERO OR LAST RESET
                                                ;IN TENTHS OF SECONDS OR REPETITIONS
                                                ;OF THE SONAR INTERRUPT CLOCK
E7EC      ASCII_L    EQU      0E7ECH     ;CONVERT LEFT NIBBLE OF A BYTE TO ASCII
E7F0      ASCII_R    EQU      0E7F0H     ;CONVERT RIGHT NIBBLE OF BYTE TO ASCII
BEF7      FWCOUNT    EQU      0BEF7H     ;FRONT WHEEL COUNT
BEF9      RWCOUNT1   EQU      0BEF9H     ;RIGHT WHEEL COUNT BACKWARD
BEFB      RWCOUNT2   EQU      0BEFBH     ;RIGHT WHEEL COUNT FORWARD
BEFD      LWCOUNT1   EQU      0BEFDH     ;LEFTWHEEL COUNT BACKWARD
BEFF      LWCOUNT2   EQU      0BEFFH     ;LEFTWHEEL COUNT FORWARD
BEEF      SOND.TSA   EQU      0BEEFH     ;AS IN 'WHERE'S THE ____'
BEF0      SONDATRA   EQU      0BEF0H     ;SONAR RANGE FOR A
BEF1      SONDATSB   EQU      0BEF1H     ;SONAR SELECT BYTE FOR B
BEF2      SONDATRB   EQU      0BEF2H     ;SONAR RANGE FOR B
BEF3      SONDATSC   EQU      0BEF3H     ;SONAR SELECT BYTE FOR C
BEF4      SONDATRC   EQU      0BEF4H     ;SONAR RANGE FOR C
BEF5      SONDATSD   EQU      0BEF5H     ;SONAR SELECT BYET FOR D
BEF6      SONDATRD   EQU      0BEF6H     ;SONAR RANGE FOR D
ED5F      SONPRINT   EQU      0ED5FH     ;SUBROUTINE THAT CONVERTS THE SONAR RANGE
                                                ;IN BINARY TO DECIMAL TENTHS OF FEET
BFC A     ADR        EQU      0BFC A H   ;DESTINATION ADDRESS FOR MOVE COMMAND
BFC C     ADDL       EQU      0BFC C H   ;START OF MOVE ADDRESS FOR MOVE COMMAND
BFC E     ADDH       EQU      0BFC E H   ;END OF MOVE ADDRESS FOR MOVE COMMAND
E646     MOVE1       EQU      0E646 H   ;SUBROUTINE ADDRESS OF MOVE COMMAND
BEE2     SONNEXA     EQU      0BEE2 H   ;NEXT SONAR TO BE SELECTED FOR A
BEE3     SONNEXB     EQU      0BEE3 H   ;NEXT SONAR TO BE SELECTED FOR B
  
```

```

BEE4      SONNEXC      EQU      0BEE4H      ;NEXT SONAR TO BE SELECTED FOR C
BEE5      SONNEXD      EQU      0BEE5H      ;NEXT SONAR TO BE SELECTED FOR D
;
;
0100      ;
0100      0F          MAININIT      SETI          ;ALLOW NO INTERRUPTS UNTIL
;INITIALIZATION IS COMPLETE
0101      8E BC 00      LDS          #TUSRAM      ;INITIALIZE STACK POINTER
0104      96 B5          LDAA         #0B5H          ;SET UP CONTROL WORD FOR TERMINAL
0106      B7 C0 00      STAA        IO+ACIAT+A.C      ;ACIA TO ALLOW INTERRUPT GENERATION
;ON BOTH TRANSMIT AND RECEIVE
0109      CE 01 21      LDX          #XTEND        ;SET UP MORETIC EXTENDED INTERRUPT
010C      FF BE C8      STX          MORETIC+1      ;HANDLER
010F      86 7E          LDAA         #07EH
0111      B7 BE C7      STAA        MORETIC
0114      CE 00 00      LDX          #XZERO
0117      FF BE D9      STX          TICTIME
011A      BD EB FB      JSR          INTPTMV        ;REINITIALIZE THE TICTIME COUNTER
011D      0E          CLI          ;ALLOW INTERRUPTS
;
;

```

```

011E      3E          TWIDDLE      WAI          ;DO NOTHING. WAIT FOR INTERRUPTS
011F      20 FD      BRA          TWIDDLE
;
;

```

```

*****
NOTE THAT THE MAIN PROGRAM IS DOING NOTHING AND *
AS SUCH CAN BE MODIFIED TO TAKE ADVANTAGE OF PROCESSOR *
CYCLES NOT USED BY THE INTERRUPT HANDLER *
*****

```

```

SUBROUTINE: XTEND      AN EXTENSION OF THE EXISTING
NAV COMPUTER INTERRUPT HANDLER.
ITS PURPOSE IS TO GATHER TIME
TAGED SONAR AND OPTICAL SHAFT
ENCODER DATA AND SEND IT OUT
THE TERMINAL PORT TO AN EXTERNAL
COMPUTER FOR POST MISSION
PROCESSING OR REAL TIME ANALYSIS
FOR DRIVE COMPUTER COMMAND GENERATION.

```

```

0121      7D BE E1      XTEND      TST          SONCHANGE      ;HAVE SONARS BEEN CHANGED SINCE
;LAST REQUEST?
0124      27 3B          BEQ          XTEND2        ;IF NOT THEN CONTINUE INTERRUPT
;PROCESSING
0126      7D 05 6A      CANDATA   TST          BUFLEFT        ;ELSE SEE IF MORE THAN 256 BYTES IN
0129      22 03          BHI          CALLRDSON      ;IN BUFFER. IF YES CALL READSONAR

```

012B	7E 01 61		JMP	XTEND2	;ELSE CONTINUE INTERRUPT PROCESSING
012E	4F	CALLROSON	CLRA		
012F	43		CONA		;CREATE A LINE OF SONAR AND USE TIME
0130	B7 BE EE		STAA	INTMASK	;TAGED DATA
0133	BD EA 54		JSR	READSONAR	;GET THE SONAR DATA AND TIME
0136	4F		CLRA		
0137	B7 BE EE		STAA	INTMASK	
013A	BD 04 2D		JSR	SONSWITCH	;SET UP NEXT SONARS TO BE USED
013D	BD 02 43		JSR	PUTTIME	;PUT TIME IN BUFFER
0140	BD 02 62		JSR	PUTFW	;PUT FRONT WHEEL COUNT IN BUFFER
0143	BD 02 6C		JSR	PUTLW	;PUT LEFT WHEEL COUNTS IN BUFFER
0146	BD 02 8B		JSR	PUTRW	;PUT RIGHT WHEEL COUNTS IN BUFFER
0149	BD 02 AA		JSR	PUTA	;PUT SONAR READINGS IN BUFFER
014C	BD 02 FA		JSR	PUTB	
014F	BD 03 4A		JSR	PUTC	
0152	BD 03 9A		JSR	PUTD	
0155	BD 03 EA		JSR	PUTLINE	;PUT THE LINE BUFFER INTO THE SPOOLER
0158	BD 04 00		JSR	DECBLEFT	;DECREMENT THE SPOOLER BUFFER BY 64
015B	BD 04 0B		JSR	ADDLEFTPR	;ADD 64 TO NUMBER LEFT TO PRINT
015E	BD 04 16		JSR	ADDBUFNX	;POINT TO NEXT AVAILABLE SPOOLER ADDRESS
0161	CE 00 00	XTEND2	LDX	#XZERO	
0164	BC 05 66		CPX	LEFTPR	;ARE CHARACTERS AVAILABLE TO TRANSMIT?
0167	26 03		BNE	XTEND3	;YES GO TRANSMIT
0169	7E 01 9A		JMP	TSTRX	;NO. CONTINUE INTERRUPT PROCESSING.
016C	7D 05 65	XTEND3	TST	MEXOFF	;IS XOFF IN EFFECT?
016F	26 29		BNE	TSTRX	;YES. GO CHECK RECEIVE BUFFER.
0171	B6 C0 00		LDA	10+ACIAT+A.S	;ELSE CHECK FOR TRANSMIT BUFFER EMPTY.
0174	47		ASRA		
0175	47		ASRA		
0176	24 22		BCC	TSTRX	;NOT EMPTY SO CHECK RECEIVE BUFFER.
0178	FE 05 68		LDX	NXCHPR	;YES EMPTY SO POINT TO NEXT CHARACTER
017B	A6 00		LDA	0,X	;GET IT AND TRANSMIT IT OUT.
017D	B7 C0 01		STAA	10+ACIAT+A.TX	
0180	08		INX		;POINT TO NEXT CHARACTER
0181	8C A0 00		CPX	#SPBUFEND+1	;IS IT THE END OF THE BUFFER?
0184	26 03		BNE	UPNXCHPR	;NO. RESTORE THE POINTER
0186	FE 05 6E		LDX	SPBUFST	;YES. POINT TO THE START OF THE BUFFER
0189	FF 05 68	UPNXCHPR	STX	NXCHPR	;RESTORE THE POINTER
018C	FE 05 66		LDX	LEFTPR	;ONE LESS TO PRINT
018F	09		DEX		
0190	FF 05 66		STX	LEFTPR	
0193	FE 05 6A		LDX	BUFLEFT	;ONE MORE FOR THE AVAILABLE BUFFER
0196	08		INX		
0197	FF 05 6A		STX	BUFLEFT	
019A	B6 C0 00	TSTRX	LDA	10+ACIAT+A.S	;CHECK TO SEE IF CHARACTER RECEIVED
019D	47		ASRA		
019E	24 25		BCC	TSTRX2	;NOTHING RECEIVED
01A0	B6 C0 01		LDA	10+ACIAT+A.RX	;YES. GET RECEIVED CHARACTER.
01A3	81 11		CHPA	#011H	;IS IT XON?
01A5	26 05		BNE	TSTRX3	;NO. CHECK FOR OTHER COMMANDS
01A7	7F 05 65		CLR	MEXOFF	;YES SO CLEAR THE XOFF FLAG
01AA	20 B5		BRA	XTEND2	;AND GO TRY TO TRANSMIT A CHARACTER

01AC	81 13	TSTRX3	CHPA	#013H	; IS IT XOFF?
01AE	26 07		BNE	TSTRX4	; NO. CHECK FOR OTHER COMMANDS
01B0	86 FF		LDAA	#0FFH	; YES. GO SET THE XOFF FLAG
01B2	B7 05 65		STAA	HEXOFF	
01B5	20 0E		BRA	TSTRX2	; END RECEIVE FUNCTION
01B7	81 07	TSTRX4	CHPA	#007	; IS IT CONTROL G?
01B9	26 00		BNE	TSTRX5	; NO. CHECK FOR OTHER COMMANDS
01BB	BD EB FB		JSR	INTPTMV	; RESET 10 HZ COUNTER
01BE	DE 00		LDX	XZERO	; YES. RESET TICTIME TO ZERO
01C0	FF BE D9		STX	TICTIME	
01C3	20 00		BRA	TSTRX2	
01C5	39	TSTRX2	RTS		; END OF INTERRUPT PROCESSING
01C6	01		NOP		
01C7	01		NOP		
01C8	81 31	TSTRX5	CHPA	#031H	; IS IT 1?
01CA	26 19		BNE	TSTRX6	; NO. CHECK FOR OTHER COMMANDS
					; YES. DO SONARS 1 AT A TIME
01CC	CE 04 B9		LDX	#PTAB1END	; POINT TO END OF TABLE
01CF	FF 04 48		STX	SONEND+1	
01D2	CE 04 5D		LDX	#PTAB1	; POINT TO START OF TABLE
01D5	FF 04 4D		STX	SONEND2+1	
01D8	FF 04 5B		STX	PTABNEXT	
01DB	BD EB FB		JSR	INTPTMV	; RESET 10 HZ COUNTER
01DE	DE 00		LDX	XZERO	; YES. RESET TICTIME TO ZERO
01E0	FF BE D9		STX	TICTIME	
01E3	20 E0		BRA	TSTRX2	
01E5	81 32	TSTRX6	CHPA	#032H	; IS IT 2?
01E7	26 19		BNE	TSTRX7	; NO. CHECK FOR OTHER COMMANDS
					; YES. DO SONARS 2 AT A TIME
01E9	CE 04 E9		LDX	#PTAB2END	; POINT TO END OF TABLE
01EC	FF 04 48		STX	SONEND+1	
01EF	CE 04 BD		LDX	#PTAB2	; POINT TO START OF TABLE
01F2	FF 04 4D		STX	SONEND2+1	
01F5	FF 04 5B		STX	PTABNEXT	
01F8	BD EB FB		JSR	INTPTMV	; RESET 10 HZ COUNTER
01FB	DE 00		LDX	XZERO	; YES. RESET TICTIME TO ZERO
01FD	FF BE D9		STX	TICTIME	
0200	20 C3		BRA	TSTRX2	
0202	81 33	TSTRX7	CHPA	#033H	; IS IT 3?
0204	26 19		BNE	TSTRX8	; NO. CHECK FOR OTHER COMMANDS
					; YES. DO SONARS 3 AT A TIME
0206	CE 05 09		LDX	#PTAB3END	; POINT TO END OF TABLE
0209	FF 04 48		STX	SONEND+1	
020C	CE 04 ED		LDX	#PTAB3	; POINT TO START OF TABLE
020F	FF 04 4D		STX	SONEND2+1	
0212	FF 04 5B		STX	PTABNEXT	
0215	BD EB FB		JSR	INTPTMV	; RESET 10 HZ COUNTER
0218	DE 00		LDX	XZERO	; YES. RESET TICTIME TO ZERO
021A	FF BE D9		STX	TICTIME	
021D	20 A6		BRA	TSTRX2	
021F	81 34	TSTRX8	CHPA	#034H	; IS IT 4?
0221	26 19		BNE	TSTRX9	; NO. CHECK FOR OTHER COMMANDS

```

0223 CE 05 21          LDX  #PTABAEND          ;YES. DO SONARS 4 AT A TIME
0226 FF 04 48          STX  SONEND+1          ;POINT TO END OF TABLE
0229 CE 05 00          LDX  #PTAB4           ;POINT TO START OF TABLE
022C FF 04 4D          STX  SONEND2+1
022F FF 04 5B          STX  PTABNEXT
0232 BD EB FB          JSR  INTPTMV          ;RESET 10 KHZ COUNTER
0235 DE 00            LDX  XZERO           ;YES. RESET TICTIME TO ZERO
0237 FF BE D9          STX  TICTIME
023A 20 89            BRA  TSTRX2
023C 81 03            CHPA #0003H         ;IS IT CONTROL C?
023E 26 85            BNE  TSTRX2         ;NO. END RECEIVE FUNCTION
0240 7E EC FC          JMP  INIT           ;JUMP TO RESET SYSTEM

;
;
;
;
SUBROUTINE: PUTTIME          PUTS TIME INTO THE LINE BUFFER
PUTTIME  LDX  #LNTIME
          LDAA TICTIME
          JSR  PUT2HEX
          LDAA TICTIME+1
          JSR  PUT2HEX
          RTS

;
;
;
;
SUBROUTINE: PUT2HEX          CONVERTS A BYTE INTO TWO ASCII
                              CHARACTERS. ON ENTRY, THE INDEX
                              REGISTER POINTS TO WHERE THE TWO
                              ASCII CHARACTERS ARE TO BE PLACED.
PUT2HEX  PSHA
          JSR  ASCIIIL          ;CONVERT THE LEFT NIBBLE
          STAA 0,X
          INX
          PULA
          JSR  ASCIIR          ;CONVERT THE RIGHT NIBBLE
          STAA 0,X
          INX
          RTS

;
;
;
;
SUBROUTINE: PUTFW           PUT FRONT WHEEL COUNT IN LINE BUFFER
PUTFW   LDX  #LNFW
          LDAA FWCOUNT+1
          JSR  PUT2HEX
          RTS

```

```

:
:
:
:
:
SUBROUTINE: PUTLM          PUT LEFT WHEEL COUNTS IN LINE BUFFER
PUTLM          LDX          #LNBLW1
                LDAA         LMCOUNT1          ;GET THE REVERSE COUNTS
                JSR          PUT2HEX
                LDAA         LMCOUNT1+1
                JSR          PUT2HEX
                LDX          #LNFLW2          ;GET THE FORWARD COUNTS
                LDAA         LMCOUNT2
                JSR          PUT2HEX
                LDAA         LMCOUNT2+1
                JSR          PUT2HEX
                RTS

```

```

:
:
:
:
:
SUBROUTINE: PUTRW          PUT RIGHT WHEEL COUNTS IN LINE BUFFER
PUTRW          LDX          #LNBRW1
                LDAA         RMCOUNT1          ;GET REVERSE COUNTS
                JSR          PUT2HEX
                LDAA         RMCOUNT1+1
                JSR          PUT2HEX
                LDX          #LNFRW2          ;GET FORWARD COUNTS
                LDAA         RMCOUNT2
                JSR          PUT2HEX
                LDAA         RMCOUNT2+1
                JSR          PUT2HEX
                RTS

```

```

:
:
:
:
SUBROUTINE: PUTA          PUT SONAR A SELECTED IN LINE BUFFER
PUTA          LDX          #LNATRANS          ;POINT TO LINE POSITION
                LDAA         SONDATSA        ;GET THE SELECTED TRANSDUCER #

```

02B0	81 01		CMPA	#1	; WAS IT 0
02B2	26 06		BNE	PUTA2	; NO CONTINUE SEARCH
02B4	86 70		LDA	#'0'	
02B6	A7 00		STAA	0,X	
02B8	20 36		BRA	PUTA8	; GO PUT DISTANCE READING
02BA	81 02	PUTA2	CMPA	#2	; WAS IT 1
02BC	26 06		BNE	PUTA3	; NO CONTINUE SEARCH
02BE	86 31		LDA	#'1'	
02C0	A7 00		STAA	0,X	
02C2	20 2C		BRA	PUTA8	; GO PUT DISTANCE READING
02C4	81 04	PUTA3	CMPA	#4	; WAS IT 2
02C6	26 06		BNE	PUTA4	; NO CONTINUE SEARCH
02C8	86 32		LDA	#'2'	
02CA	A7 00		STAA	0,X	
02CC	20 22		BRA	PUTA8	; GO PUT DISTANCE READING
02CE	81 10	PUTA4	CMPA	#010H	; WAS IT 4
02D0	26 06		BNE	PUTA5	; NO CONTINUE SEARCH
02D2	86 34		LDA	#'4'	
02D4	A7 00		STAA	0,X	
02D6	20 18		BRA	PUTA8	; GO PUT DISTANCE READING
02D8	81 20	PUTA5	CMPA	#020H	; WAS IT 5
02DA	26 06		BNE	PUTA6	; NO CONTINUE SEARCH
02DC	86 35		LDA	#'5'	
02DE	A7 00		STAA	0,X	
02E0	20 0E		BRA	PUTA8	; GO PUT DISTANCE READING
02E2	81 40	PUTA6	CMPA	#040H	; WAS IT 6
02E4	26 06		BNE	PUTA7	; NO CONTINUE SEARCH
02E6	86 36		LDA	#'6'	
02E8	A7 00		STAA	0,X	
02EA	20 04		BRA	PUTA8	; GO PUT DISTANCE READING
02EC	86 2A	PUTA7	LDA	#'8'	
02EE	A7 00		STAA	0,X	
02F0	B6 BE F0	PUTA8	LDA	SONDATRA	; GET THE DISTANCE READING
02F3	CE 05 45		LX	#LNAREADING	; POINT TO THE LINE POSITION
02F6	BD ED 5F		JSR	SONPRINT	; CONVERT THE READING TO DECIMAL
					; AND PUT IT IN THE LINE BUFFER
02F9	39		RTS		; RETURN TO CALLER

;
;
;
;
;
;
;
;
;

02FA CE 05 4B
02FD B6 BE FI
0300 81 01
0302 26 06
0304 86 30
0306 A7 00
0308 20 36

PUTB

SUBROUTINE:	PUTB	PUT SONAR B SELECTED IN LINE BUFFER
LX	#LNTRANS	; POINT TO LINE POSITION
LDA	SONDATSB	; GET THE SELECTED TRANSDUCER #
CMPA	#1	; WAS IT 0
BNE	PUTB2	; NO CONTINUE SEARCH
LDA	#'0'	
STAA	0,X	
BRA	PUTB3	; GO PUT DISTANCE READING

```

030A 81 02      PUTB2  CHPA  #2      ;WAS IT 1
030C 26 06      BNE   PUTB3  ;NO CONTINUE SEARCH
030E 86 31      LDAA  #'1'
0310 A7 00      STAA  0,X
0312 20 2C      BRA   PUTB8  ;GO PUT DISTANCE READING
0314 81 04      PUTB3  CHPA  #4      ;WAS IT 2
0316 26 06      BNE   PUTB4  ;NO CONTINUE SEARCH
0318 86 32      LDAA  #'2'
031A A7 00      STAA  0,X
031C 20 22      BRA   PUTB8  ;GO PUT DISTANCE READING
031E 81 10      PUTB4  CHPA  #010H ;WAS IT 4
0320 26 06      BNE   PUTB5  ;NO CONTINUE SEARCH
0322 86 34      LDAA  #'4'
0324 A7 00      STAA  0,X
0326 20 18      BRA   PUTB8  ;GO PUT DISTANCE READING
0328 81 20      PUTB5  CHPA  #020H ;WAS IT 5
032A 26 06      BNE   PUTB6  ;NO CONTINUE SEARCH
032C 86 35      LDAA  #'5'
032E A7 00      STAA  0,X
0330 20 0E      BRA   PUTB8  ;GO PUT DISTANCE READING
0332 81 40      PUTB6  CHPA  #040H ;WAS IT 6
0334 26 06      BNE   PUTB7  ;NO CONTINUE SEARCH
0336 86 36      LDAA  #'6'
0338 A7 00      STAA  0,X
033A 20 04      BRA   PUTB8  ;GO PUT DISTANCE READING
033C 86 2A      PUTB7  LDAA  #'*'
033E A7 00      STAA  0,X
0340 B6 BE F2    PUTB8  LDAA  SONDATRB ;GET THE DISTANCE READING
0343 CE 05 4C    LDX   #LNBREADING ;POINT TO THE LINE POSITION
0346 BD ED 5F    JSR   SONPRINT  ;CONVERT THE READING TO DECIMAL
                                ;AND PUT IT IN THE LINE BUFFER
0349 39          RTS   ;RETURN TO CALLER

```

```

;
;
;
;
;
;
SUBROUTINE:  PUTC          PUT SONAR C SELECTED IN LINE BUFFER
034A CE 05 52    PUTC  LDX   #LNCNTRANS ;POINT TO LINE POSITION
034D B6 BE F3    LDAA  SONDATSC ;GET THE SELECTED TRANSDUCER #
0350 81 01      CHPA  #1      ;WAS IT 0
0352 26 06      BNE   PUTC2  ;NO CONTINUE SEARCH
0354 86 30      LDAA  #'0'
0356 A7 00      STAA  0,X
0358 20 36      BRA   PUTC8  ;GO PUT DISTANCE READING
035A 81 02      PUTC2  CHPA  #2      ;WAS IT 1
035C 26 06      BNE   PUTC3  ;NO CONTINUE SEARCH
035E 86 31      LDAA  #'1'
0360 A7 00      STAA  0,X
0362 20 2C      BRA   PUTC8  ;GO PUT DISTANCE READING
0364 81 04      PUTC3  CHPA  #4      ;WAS IT 2

```

```

0366 26 06          BNE    PUTC4          ;NO CONTINUE SEARCH
0368 86 32          LDAA   #'2'
036A A7 00          STAA   0,X
036C 20 22          BRA    PUTC8          ;GO PUT DISTANCE READING
036E 81 10          CMPA   #010H        ;WAS IT 4
0370 26 06          BNE    PUTC5          ;NO CONTINUE SEARCH
0372 86 34          LDAA   #'4'
0374 A7 00          STAA   0,X
0376 20 18          BRA    PUTC8          ;GO PUT DISTANCE READING
0378 81 20          CMPA   #020H        ;WAS IT 5
037A 26 06          BNE    PUTC6          ;NO CONTINUE SEARCH
037C 86 35          LDAA   #'5'
037E A7 00          STAA   0,X
0380 20 0E          BRA    PUTC8          ;GO PUT DISTANCE READING
0382 81 40          CMPA   #040H        ;WAS IT 6
0384 26 06          BNE    PUTC7          ;NO CONTINUE SEARCH
0386 76 36          LDAA   #'6'
0388 A 00           STAA   0,X
038A 20 04          BRA    PUTC8          ;GO PUT DISTANCE READING
038C 86 2A          CMPA   #'8'
038E A7 00          STAA   0,X
0390 B6 BE F4       PUTC8   LDAA   SONDATRC      ;GET THE DISTANCE READING
0393 CE 05 53       LDX    #LNCREADING  ;POINT TO THE LINE POSITION
0396 BD ED 5F       JSR    SONPRINT     ;CONVERT THE READING TO DECIMAL
                                ;AND PUT IT IN THE LINE BUFFER
                                ;RETURN TO CALLER
0399 39             RTS

```

```

;
;
;
;
;
SUBROUTINE:  PUTD          PUT SONAR D SELECTED IN LINE BUFFER
039A CE 05 59       PUTD   LDX    #LNDRANS      ;POINT TO LINE POSITION
039D B6 BE F5       LDAA   SONDATSD      ;GET THE SELECTED TRANSDUCER #
03A0 81 01          CMPA   #1             ;WAS IT 0
03A2 26 06          BNE    PUTD2          ;NO CONTINUE SEARCH
03A4 86 30          LDAA   #'0'
03A6 A7 00          STAA   0,X
03A8 20 36          BRA    PUTD8          ;GO PUT DISTANCE READING
03AA 81 02          CMPA   #2             ;WAS IT 1
03AC 26 06          BNE    PUTD3          ;NO CONTINUE SEARCH
03AE 86 31          LDAA   #'1'
03B0 A7 00          STAA   0,X
03B2 20 2C          BRA    PUTD8          ;GO PUT DISTANCE READING
03B4 81 04          CMPA   #4             ;WAS IT 2
03B6 26 06          BNE    PUTD4          ;NO CONTINUE SEARCH
03B8 86 32          LDAA   #'2'
03BA A7 00          STAA   0,X
03BC 20 22          BRA    PUTD8          ;GO PUT DISTANCE READING
03BE 81 10          CMPA   #010H        ;WAS IT 4
03C0 26 06          BNE    PUTD5          ;NO CONTINUE SEARCH

```

```

03C2 86 34          LDAA 0'4'
03C4 A7 00          STAA 0,X
03C6 20 18          BRA PUTD8          ;GO PUT DISTANCE READING
03C8 81 20          CMPA 0020H        ;WAS IT 5
03CA 26 06          BNE PUTD6          ;NO CONTINUE SEARCH
03CC 86 35          LDAA 0'5'
03CE A7 00          STAA 0,X
03D0 20 0E          BRA PUTD8          ;GO PUT DISTANCE READING
03D2 81 40          CMPA 0040H        ;WAS IT 6
03D4 26 06          BNE PUTD7          ;NO CONTINUE SEARCH
03D6 86 36          LDAA 0'6'
03D8 A7 00          STAA 0,X
03DA 20 04          BRA PUTD8          ;GO PUT DISTANCE READING
03DC 86 2A          LDAA 0'7'
03DE A7 00          STAA 0,X
03E0 86 BE F6       LDAA SONDATRD      ;GET THE DISTANCE READING
03E3 CE 05 5A       LDX  #LNDREADING   ;POINT TO THE LINE POSITION
03E6 BD ED 5F       JSR  SONPRINT      ;CONVERT THE READING TO DECIMAL
                                     ;AND PUT IT IN THE LINE BUFFER
03E9 39             RTS          ;RETURN TO CALLER

```

```

;
;
SUBROUTINE: PUTLINE          PUT LINE BUFFER IN SPOOLER BUFFER
;
;
03EA CE 05 25       FUTURE LDX  #LNSTART      ;POINT TO START OF LINE BUFFER
03ED FF BF CC       STX  ADOL
03F0 CE 05 65       LDX  #LNEND+6          ;POINT TO END OF LINE BUFFER
03F3 FF BF CE       STX  ADCH
03F6 FE 05 6C       LDX  SPUFNX          ;POINT TO POSITION OF SPOOLER BUFFER
03F9 FF BF CA       STX  ADR
03FC BD E6 46       JSR  MOVE1          ;MOVE THE LINE
03FF 39             RTS

```

```

;
;
SUBROUTINE: DECBLEFT        DECREMENT BY 54 THE AMOUNT LEFT IN
;                             THE SPOOLER BUFFER
;
;
0400 FE 05 6A       DECBLEFT LDX  BUFLEFT
0403 C6 40          LDAB  #64
0405 3F             SWI
0406 0E             FCB  00EH
0407 FF 05 6A       STX  BUFLEFT
040A 39             RTS

```

```

;
;
SUBROUTINE: ADDLEFTPR      ADD 54 TO THE NUMBER LEFT TO PRINT
;
;

```

040B FE 05 66
040E C6 40
0410 3F
0411 0A
0412 FF 05 66
0415 39

ADOLEFTPR LDX LEFTPR
LDAB 064
SWI
FCB 00AH
STX LEFTPR
RTS

SUBROUTINE: ADDBUFNX ADD 64 TO THE NEXT BUFFER POINTER

0416 FE 05 6C
0419 C6 40
041B 3F
041C 0A
041D 8C A0 00
0420 27 04
0422 FF 05 6C
0425 39
0426 CE 20 00
0429 FF 05 6C
042C 39

ADDBUFNX LDX SPBUFNX ;GET THE PRESENT 'NEXT LINE'
;POINTER
LDAB 0040H ;ELSE ADD 64 TO THE POINTER
SWI
FCB 00AH
CPX #SPBUFEND+1 ;IS IT THE END OF THE BUFFER?
BEQ ADDBUF2 ;IF YES RESET TO START OF BUFFER
STX SPBUFNX ;STORE THE NEW POINTER
RTS ;RETURN TO CALLER
ADDBUF2 LDX #SPBUFSTAR ;POINT TO THE START OF THE BUFFER
STX SPBUFNX ;STORE THE NEW POINTER
RTS ;RETURN TO CALLER

SUBROUTINE: SONSWITCH SWITCHES THE SELECTED SONAR
TRANSDUCERS IN A PATTERN CONTAINED IN A
USER DEFINED TABLE. BEFORE ENTRY, SONCHANGE
MUST BE \$55

042D FE 04 5B
0430 A6 00
0432 B7 BE E2
0435 A6 01
0437 B7 BE E3
043A A6 02
043C B7 BE E4
043F A6 03
0441 B7 BE E5
0444 7F BE E1
0447 8C 04 E9
044A 26 07
044C CE 04 BD
044F FF 04 5B

SONSWITCH LDX PTABNEXT ;GET POINTER TO NEXT TABLE ENTRY
LDAA 0,X ;GET TABLE ENTRY FOR A SONAR
STAA SONNEXA ;STORE THE TRANSDUCER SELECT BYTE
LDAA 1,X ;GET TABLE ENTRY FOR B SONAR
STAA SONNEXB ;STORE THE TRANSDUCER SELECT BYTE
LDAA 2,X ;GET TABLE ENTRY FOR C SONAR
STAA SONNEXC ;STORE THE TRANSDUCER SELECT BYTE
LDAA 3,X ;GET TABLE ENTRY FOR D SONAR
STAA SONNEXD ;STORE THE TRANSDUCER SELECT BYTE
CLR SONCHANGE ;TELL TICHANZ TO CHANGE THE SONARS
CPX #PTAB2END ;IS THIS THE LAST OF THE TABLE?
BNE SONSM2 ;IF NO THEN BRANCH
SONEND LDX #PTAB2 ;ELSE RESET TO START OF TABLE
STX PTABNEXT ;STORE THE POINTER

0452	39		RTS		
0453	08	SONSM2	INX		;AND RETURN TO CALLER
0454	08		INX		;POINT TO NEXT TABLE ENTRY
0455	08		INX		
0456	08		INX		
0457	FF 04 58		STX	PTABNEXT	;STORE THE POINTER
045A	39		RTS		;RETURN TO CALLER
045B	04 80	PTABNEXT	FDB	PTAB2	
045D	01 00 00 00	PTAB1	FCB	1,0,0,0	
0461	00 01 00 00		FCB	0,1,0,0	
0465	00 00 01 00		FCB	0,0,1,0	
0469	00 00 00 01		FCB	0,0,0,1	
046D	02 00 00 00		FCB	2,0,0,0	
0471	00 02 00 00		FCB	0,2,0,0	
0475	00 00 02 00		FCB	0,0,2,0	
0479	00 00 00 02		FCB	0,0,0,2	
047D	04 00 00 00		FCB	4,0,0,0	
0481	00 04 00 00		FCB	0,4,0,0	
0485	00 00 04 00		FCB	0,0,4,0	
0489	00 00 00 04		FCB	0,0,0,4	
048D	10 00 00 00		FCB	16,0,0,0	
0491	00 10 00 00		FCB	0,16,0,0	
0495	00 00 10 00		FCB	0,0,16,0	
0499	00 00 00 10		FCB	0,0,0,16	
049D	20 00 00 00		FCB	32,0,0,0	
04A1	00 20 00 00		FCB	0,32,0,0	
04A5	00 00 20 00		FCB	0,0,32,0	
04A9	00 00 00 20		FCB	0,0,0,32	
04AD	40 00 00 00		FCB	64,0,0,0	
04B1	00 40 00 00		FCB	0,64,0,0	
04B5	00 00 40 00		FCB	0,0,64,0	
04B9	00 00 00 40	PTABIEND	FCB	0,0,0,64	
04BD	01 00 01 00	PTAB2	FCB	1,0,1,0	
04C1	00 01 00 01		FCB	0,1,0,1	
04C5	02 00 02 00		FCB	2,0,2,0	
04C9	00 02 00 02		FCB	0,2,0,2	
04CD	04 00 04 00		FCB	4,0,4,0	
04D1	00 04 00 04		FCB	0,4,0,4	
04D5	10 00 10 00		FCB	16,0,16,0	
04D9	00 10 00 10		FCB	0,16,0,16	
04DD	20 00 20 00		FCB	32,0,32,0	
04E1	00 20 00 20		FCB	0,32,0,32	
04E5	40 00 40 00		FCB	64,0,64,0	
04E9	00 40 00 40	PTAB2END	FCB	0,64,0,64	
04ED	01 02 04 00	PTAB3	FCB	1,2,4,0	
04F1	02 04 00 01		FCB	2,4,0,1	
04F5	04 00 01 02		FCB	4,0,1,2	
04F9	00 01 02 04		FCB	0,1,2,4	
04FD	10 20 40 00		FCB	16,32,64,0	
0501	20 40 00 10		FCB	32,64,0,16	
0505	40 00 10 20		FCB	64,0,16,32	
0509	00 10 20 40	PTAB3END	FCB	0,16,32,64	

0500	01 01 01 01	PTAB4	FCB	1,1,1,1
0511	02 02 02 02		FCB	2,2,2,2
0515	04 04 04 04		FCB	4,4,4,4
0519	10 10 10 10		FCB	16,16,16,16
051D	20 20 20 20		FCB	32,32,32,32
0521	40 40 40 40	PTAB4END	FCB	64,64,64,64

```

; THE FOLLOWING FORMAT IS USED FOR THE DATA FILE:
; /time/fu/lw1/lw2/rw1/rw2/A#____/B#____/C#____/D#____/ <CR> <LF>
; WHERE time = TENTH'S OF SECONDS COUNT - 2 BYTES
; fu = FRONT WHEEL POSITION - 1 BYTE
; lw#,rw# = REAR WHEEL COUNTS - 2 BYTES EA.
; A#____ = SONAR NUMBER AND READING - 4 BYTES EA.
;
;
;

```

0525	09	LNSTART	FCB	09H
0526	2F	LNBUF	FCC	'/'
0527	74 69 6D 65	LNTIME	FCC	'time/'
0528	2F			
052C	66 77 2F	LNFW	FCC	'fu/'
052F	62 6C 77 31	LNBLW1	FCC	'blw1/'
0533	2F			
0534	66 6C 77 32	LNFLW2	FCC	'flw2/'
0538	2F			
0539	62 72 77 31	LNBRW1	FCC	'brw1/'
0530	2F			
053E	66 72 77 32	LNFRW2	FCC	'frw2/A'
0542	2F 41			
0544	23	LNATRANS	FCC	'B'
0545	5F 5F 5F 5F	LNAREADING	FCC	'____/B'
0549	2F 42			
054B	23	LNSTRANS	FCC	'B'
054C	5F 5F 5F 5F	LNREADING	FCC	'____/C'
0550	2F 43			
0552	23	LNCTTRANS	FCC	'B'
0553	5F 5F 5F 5F	LNCFREADING	FCC	'____/D'
0557	2F 44			
0559	23	LNCTTRANS	FCC	'B'
055A	5F 5F 5F 5F	LNCFREADING	FCC	'____/E'
055E	2F			
055F	0D 0A 00 00	LNEND	FCB	0DH,0AH,0,0,0,0
0563	00 00			
0565	00	MEXOFF	FCB	0
0566	00 00	LEFTPR	FDB	0
0568	20 00	NXCHPR	FDB	SPBUFSTAR
056A	80 00	BULEFT	FDB	08000H
056C	20 00	SPBUFNX	FDB	SPBUFSTAR
056E	20 00	SPBUFST	FDB	SPBUFSTAR
2000			ORG	02000H
2000		SPBUFSTAR	RMB	07FFFH
9FFF		SPBUFEND	END	

No error(s).

SYMBOL TABLE FOR FILE XTEND.A

A.C	0000	A.RX	0001	A.S	0000	A.TX	0001
ACIAT	0000	ADDBUF2	0426	ADDBUFNX	0416	ADJH	BFCE
ADDL	BFCC	ADDLEFTP	0408	ADR	BFCA	ASCIIIL	E7EC
ASCIIR	E7F0	BUFLEFT	056A	CALLRDSO	012E	CANDATA	0126
DECBLEFT	0400	FWCOUNT	BEF7	INIT	ECFC	INTMASK	BEEE
INTPTMV	EBFB	IO	C000	LEFTPR	0566	LNAREADI	0545
LNATRANS	0544	LNBLWI	052F	LNAREADI	054C	LNBRWI	0539
LNBRANS	0548	LNBUF	0526	LNCREADI	0553	LNCTRANS	0552
LNREADI	055A	LNDRANS	0559	LNEND	055F	LNFLW2	0534
LNFRW2	053E	LNFM	052C	LNSTART	0525	LNTIME	0527
LMCOUNT1	BEFD	LMCOUNT2	BEFF	MAININIT	0100	MEYOFF	0565
MORETIC	BEC7	MOVE1	E646	NXCHPR	0568	PTAB1	0450
PTABIEND	0489	PTAB2	0480	PTAB2END	04E9	PTAB3	04ED
PTAB3END	0509	PTAB4	0500	PTABAEND	0521	PTABNEXT	0458
PUT2HEX	0253	PUTA	02AA	PUTA2	02BA	PUTA3	02C4
PUTA4	02CE	PUTA5	02D8	PUTA6	02E2	PUTA7	02EC
PUTA8	02F0	PUTB	02FA	PUTB2	030A	PUTB3	0314
PUTB4	031E	PUTB5	0328	PUTB6	0332	PUTB7	033C
PUTB8	0340	PUTC	034A	PUTC2	035A	PUTC3	0364
PUTC4	036E	PUTC5	0378	PUTC6	0382	PUTC7	038C
PUTC8	0390	PUTD	039A	PUTD2	03AA	PUTD3	0384
PUTD4	03BE	PUTD5	03C8	PUTDL	03D2	PUTD7	03DC
PUTD8	03E0	PUTFW	0262	PUTLINE	03EA	PUTLW	026C
PUTRW	0288	PUTTIP	0243	READSONA	EA54	RWCOUNT1	BEF9
RWCOUNT2	BEFB	SONCHANG	BEE1	SONDATRA	BEF0	SONDATR8	BEF2
SONDATRC	BEF4	SONDATRO	BEF6	SONDATSA	BEEF	SONDATS8	BEF1
SONDATSC	BEF3	SONDATSD	BEF5	SONEND	0447	SONEND2	044C
SONNEXA	BEE2	SONNEXB	BEE3	SONNEXC	BEE4	SONNEXD	BEE5
SONPRINT	ED5F	SONSW2	0453	SONSWITC	0420	SPBUFEND	9FFF
SPBUFNX	056C	SPBUFST	056E	SPBUFSTA	2000	TICTIME	BED9
TSTRX	019A	TSTRX2	01C5	TSTRX3	01AC	TSTRX4	0187
TSTRX5	01C8	TSTRX6	01E5	TSTRX7	0202	TSTRX8	021F
TSTRX9	023C	TUSRAM	BC00	TWIDDLE	011E	UPNXCHPR	0189
XOFF	0013	XON	0011	XTEND	0121	XTEND2	0161
XTEND3	016C	XZERO	0000				

APPENDIX C

```

10 '
20 'DATE: 25 OCT 84
30 '
40 '***** M A P P E R *****
50 '
60 'THIS PROGRAM IS DESIGNED TO RUN ON A TRS-80 COLOR COMPUTER
70 'IT IS WRITTEN IN MICROSOFT DISK EXTENDED COLOR BASIC
80 'THE PURPOSE OF THIS PROGRAM IS TO TRANSFORM SONAR READINGS
85 'FROM THE AFIT ROBOT MARRS-1 INTO GRAPHICS FORMAT
90 'THE TEST ROOM IS 13' X 22' AND EACH PIXEL REPRESENTS 0.1 FT
100 'PROGRAM CONCEIVED AND WRITTEN BY CAPT HUBERT G. SCHNEIDER III
110 '
120 '
130 '
140 '
150 'MEMORY INITIALIZATION
160 CLEAR1000,3H6FFF:PCLEAR8:PMODE4,1:DEFUSR0 = &H7000
170 LOADM"ANDPAGE"
180 PMODE4,5:PCLS1:PMODE4,1:PCLS1
190 '
200 '
210 '
220 '
230 '
240 'GLOBAL DECLARATIONS
250 LI=0:L2=0:L3=0:L4=0:L5=0:R1=0:R2=0:R3=0:R4=0:R5=0:LM=0:RM=0
260 D=17.75:'DISTANCE BETWEEN REAR WHEELS IN INCHES
270 SN#="A0A4A1A5A2A6B0B4B1B5B2B6C0C4C1C5C2C6L0D4D1D5D2D6":' SONAR LOOKUP TABLE
280 C = 0:'COLOR
290 PI = 3.14159
300 '
310 'THE FOLLOWING FORMAT IS USED FOR THE DATA FILE:
320 '/time/fw/lw1/lw2/rw1/rw2/A#___/B#___/C#___/D#___/ <CR> <LF>
330 'WHERE time = TENTH'S OF SECONDS COUNT - 2 BYTES
340 '      fw = FRONT WHEEL DIRECTION - 1 BYTE
350 '      lw1,rw1 = REAR WHEEL COUNTS - 2 BYTES EA.
360 '      A#___ = SONAR NUMBER AND READING - 4 BYTES EA.
370 '
380 'MAIN PROGRAM
390 '
400 '      GET INITIAL INFORMATION
410 '      GOSUB 1910
420 '
430 '      GET DRIVE NUMBERS
440 '      GOSUB1990
450 '
460 '      OPEN DATA FILE
470 '      GOSUB 2000
480 '
490 '      READ IN DATA

```

```

500 ' PCLS1
510 SCREEN1,1
520 FOR I=1TO6
530 SD$=""
540 LINEINPUT #1,SD$
550 IF EOF(1)=-1 THEN 720 : 'CHECK FOR END OF FILE
560 FOR J=1TO11
570 P1=INSTR(1,SD$,"/")
580 A$=LEFT$(SD$,P1-1)
590 ON J GOSUB 840,870,930,960,1000,1040,1080,1500,1500,1500,1500
600 SD$=RIGHT$(SD$,LEN(SD$)-P1)
610 NEXT J
620 NEXT I
630 Q=USR0(0) : 'CALL ML ROUTINE "ANDPAGE"
640 '
650 ' Z$=INKEY$:IF Z$="" THEN 322 : ' THESE LINES ARE FOR
660 ' IF Z$="S" THEN 330 ELSE 360 : ' THE OPTION OF SAVING
670 ' SAVE PICTURE : ' EACH INCREMENTAL
680 ' F$=TIME$+".BIN:"+DN$ : ' PICTURE OF WHAT THE
690 ' GOSUB1830 : ' SONARS "SEE"
700 ' GOTO 490 : 'CONTINUE
710 '
720 ' CLOSE DATA FILE
730 ' GOSUB 2120
740 '
750 ' SAVE COMPOSITE PICTURE
760 ' FOR X= 5 TO 8:PCOPY X TO X-4:NEXT X:F$=T1$+"#COMP/BIN:"+DN$
770 ' GOSUB1830
780 '
790 END
800 '*****END OF PROGRAM*****
810 '
820 '*****SUBROUTINES*****
830 '
840 'FIND FIRST DELIMITER IN DATA STRING ("/")
850 RETURN
860 '
870 'GET TIME
880 'TIC - COUNT FROM ROBOT
890 'TIME$ - DECIMAL COUNT
900 IF I=1 THEN TIME$=T1$+"0"+A$ ELSE RETURN
910 RETURN
920 '
930 'CONVERT FWCOUNT TO A VALUE
940 FW = VAL("&H"+A$) :RETURN
950 '
960 'CONVERT LWCOUNT1 TO A VALUE (LEFT WHEEL BACKWARDS)
970 LW=VAL("&H"+A$)
980 L1 = LW-L4:L4=LW:RETURN
990 '
1000 'CONVERT LWCOUNT2 TO A VALUE (LEFT WHEEL FORWARDS)
1010 LW=VAL("&H"+A$)

```

```

1020 L2 = LW-L5:L5=LW:RETURN
1030 '
1040 'CONVERT RMCOUNT1 TO A VALUE (RIGHT WHEEL BACKWARDS)
1050 RW=VAL("&H"+A$)
1060 R1= RW-R4:R4=RW:RETURN
1070 '
1080 'CONVERT RMCOUNT2 TO A VALUE (RIGHT WHEEL FORWARDS)
1090 RW=VAL("&H"+A$)
1100 R2 = RW-R5:R5=RW:GOSUB1110:PSET(X,Y,0):RETURN
1110 '
1120 'CALCULATE POSITION AND HEADING
1130 GOSUB1180 : 'FIRST CALCULATE IN INCHES
1140 GOSUB1430 : 'THEN CONVERT TO GRAPHICS FORMAT
1150 XA=XB:YA=YB
1160 RETURN
1170 '
1180 ' DETERMINE HEADING & POSITION
1190 ' HEADING & POSITION ARE RELATIVE TO THE CENTER POINT BETWEEN THE WHEELS
1200 ' WHILE THE SONAR READINGS ARE RELATIVE TO THE CENTER OF THE ROBOT
1210 ' (XA,YA) - PREVIOUS POSITION
1220 ' (XB,YB) - CURRENT POSITION
1230 ' HA & HB ARE IN RADIANS
1240 ' HA - INITIAL HEADING
1250 ' HB - CURRENT HEADING
1260 ' H - GRAPHICS HEADING (0-1)
1270 ' D - DISTANCE BETWEEN WHEELS ( 17.75" )
1280 ' *** NOTE ***
1290 ' FOR PURPOSES OF THIS TEST AND THESIS,
1300 ' THE UPPER LEVEL SONARS WILL REMAIN IN A FIXED POSITION
1310 ' DURING THE TEST (I.E. NO HEAD MOVEMENTS,
1320 '
1330 L3 = L2:R3 = R2
1340 DLR =L5-R5
1350 HB =(DLR/D) + HA
1360 HC=COS(HB):HS=SIN(HB)
1370 XB = XA +(((R3+L3)/2) * HC)
1380 YB = YA +(((R3+L3)/2) * HS)
1390 'NORMALIZE HEADING
1400 H = HB/(2*PI):IF H < 0 THEN H = 1 + H ELSE IF H=0 THEN H=1
1410 IF H>1 THEN H=H-1:GOTO 1410
1420 RETURN
1430 ' GET (X,Y)
1440 ' THIS ROUTINE CONVERTS THE (XB,YB) LOCATIONS INTO INTEGER NUMBERS
1445 ' SO THAT EACH PIXEL REPRESENTS 0.1 FT
1450 ' X OFFSET -> 17, Y OFFSET -> 30
1460 X=INT(((XB+(6*HC))*10)/12)+17
1470 Y=INT(((YB+(6*HS))*10)/12)+30
1480 RETURN
1490 '
1500 ' DISPLAY SONAR DATA
1510 A1$=LEFT$(A$,2):A2$=RIGHT$(A$,LEN(A$)-2)
1520 GOSUB1550:GOSUB1680:GOSUB1740

```

```

1530 RETURN
1540 '
1550 '   CALCULATE DIRECTION OF SONAR BEAM
1560 'A1$ - SONAR NUMBER
1570 'H - HEADING (0 - 1)
1580 'S1 - START ARC POSITION
1590 'S2 - STOP ARC POSITION
1600 IF H=1 THEN H=0
1610 SN=INT((INSTR(1,SN$,A1$)/2))
1630 S1=-.025+(SN/24)+H
1640 S2=S1+.05
1650 IF H=0 THEN H=1
1660 RETURN
1670 '
1680 '   CALCULATE RADIUS (RANGE OF TARGET)
1690 R=VAL(A2$)*10
1700 IF (R>75 OR R<18 OR R=255) THEN R=0
1710 IF RIGHT$(A1$,1)="*" THEN R=0
1720 RETURN
1730 '
1740 '   DRAW SONAR ARC
1750 ' X - X DIRECTION - GRAPHICS LOCATION
1760 ' Y - Y DIRECTION - GRAPHICS LOCATION
1770 ' R - RADIUS
1780 ' C - COLOR
1790 IF S1<0 THEN CIRCLE(X,Y),R,C,1,S1+1,0:CIRCLE(X,Y),R,C,1,0,S2 ELSE CIRCLE(X,Y),R,C,1,S1,S2
1810 RETURN
1820 '
1830 '   SAVE SONAR PICTURE
1840 FR=FREE(DN):IF FR<3 THEN 1850 ELSE 1870
1850 SOUND100,10:CLS:PRINT"  D I S K  F U L L  ! ! ! ! "
1855 PRINT"PLEASE CHANGE DISK IN DRIVE  NUMBER "DN" AND PRESS ENTER TO CONTINUE"
1860 Z$=INKEY$:IF Z$=""THEN 1860 ELSE 1840
1870 SAVEM F$,&HE00,&H25FF,&H0000
1880 SCREEN1,1
1890 RETURN
1900 '
1910 '   GET INITIAL HEADING AND POSITION
1920 CLS:PRINT"PLEASE INPUT INITIAL HEADING AND POSITION OF ROBOT FOR THIS TEST RUN."
1925 PRINT"POSITION IN TERMS OF (X,Y)"
1927 PRINT"WHERE X AND Y ARE TENTHS OF FEET AND HEADING IS BETWEEN 0 AND 1."
1930 INPUT"HEADING";H:HA=2*PI*H:IF HA=0 THEN HA=2*PI
1940 INPUT"POSITION X";X:INPUT"POSITION Y";Y:XA=1.2*X:YA=1.2*Y
1950 PR. IT"INPUT DATA FILENAME":PRINT:LINEINPUT T1$:T$=T1$+$/DAT"
1960 R$=MID$(T1$,3,1):' GET ROOM CONFIGURATION NUMBER
1970 RETURN
1980 '
1990 '   GET DRIVE NUMBERS
2000 CLS:PRINT" WELCOME":PRINT" TO THE LAB OF MAKE BELIEVE!"
2010 PRINT:PRINT:PRINT
2020 PRINT"WHICH DRIVE HAS THE SONAR/OSE DATA IN IT?"
2030 A$=INKEY$:IF A$=""THEN 2030

```

```

2040 A=VAL(A$): IF A= 0 THEN DN = 1:DRIVE(0):DN1="1" ELSE IF A=1 THEN DN = 0:DRIVE(1):DN1="0" ELSE 2030
2050 PRINT:PRINT"          THANK YOU"
2060 RETURN
2070 '
2080 '   OPEN FILE
2090 OPEN"1",#1,T$
2100 RETURN
2110 '
2120 '   CLOSE FILE
2130 CLOSE #1
2140 RETURN
2150 '
2160 '
2170 '
2180 '
2190 '
2200 '*****
2210 '*                                     *
2220 '*   NAME: ANDPAGE                                     *
2230 '*   WRITTEN IN 6809 MACHINE CODE                                     *
2240 '*   THIS ROUTINE MAKES A COMPOSITE OF PAGES-1                                     *
2250 '*   SONAR/USE DATA BY ANDING ONE PAGE WITH ANOTHER. THIS PROGRAM DESIGNED TO RUN *
2260 '*   WITH ANOTHER. THIS PROGRAM DESIGNED TO RUN *
2270 '*   ON A TRS-80 COLOR COMPUTER *
2280 '*                                     *
2290 '*****
2300 '   ORG   $7000
2310 '   PSHS  Y           *SAVE Y REGISTER
2320 '   LDX   $1E00       *START OF PAGE 1
2330 '   LDY   $12600      *START OF PAGE 2
2340 ' LOOP  LDA   ,X+     *GET BYTE FROM PAGE 1
2350 '       ANDA  ,Y       *AND IT WITH BYTE FROM PAGE 2
2360 '       STA   ,Y+     *STORE BACK IN PAGE 2
2370 '       CMPX  $12600   *DONE YET?
2380 '       BNE  LOOP     *IF NOT CONTINUE
2390 '       PULS  Y       *GET BACK Y
2400 '       RTS                    *RETURN
2410 '   END

```

171

```

;*****
;*
;*          APPENDIX D
;*
;******

```

```

;          FILE: NAVDEF.A
0000      get navdef.a          ;NAV COMPUTER EQUATES AND SYS RAM USAGE
;
;          NAVDEF.A DEFINES THE INPUT/OUTPUT AND SYSTEM RAM USAGE FOR
;          THE MARRS-1 NAVIGATION COMPUTER
;
BC00      TUSRAM   EQU 0BC00H          ;TOP OF USER STACK RAM (STACKS GROW DOWNWARD)
BE00      OSRAM   EQU TUSRAM+0200H     ;BASE ADDRESS FOR OPERATING SYSTEM RAM
BE00      USRSTAK EQU OSRAM           ;USER STACK
BE7F      BOS    EQU OSRAM+07FH       ;BOTTOM OF OPERATING SYSTEM STACK (BOS)
;
;
;          INPUT/OUTPUT EQUATE AREA
;
C000      IO      EQU 0C000H          ;BASE ADDRESS FOR ALL INPUT/OUTPUT
;
;
0000      ACIAT   EQU 0                ;TERMINAL ACIA OFFSET FROM I/O BASE ADDRESS
0000      A.T     EQU ACIAT
0008      ACIAX   EQU 8                ;XTRA ACIA OFFSET FROM I/O BASE ADDRESS
0008      A.X     EQU ACIAX
0010      ACIAL   EQU 16               ;LASER ACIA OFFSET FROM I/O BASE ADDRESS
0010      A.L     EQU ACIAL
;
;
0018      PTMAB   EQU 24               ;SONAR A&B TIMER OFFSET FROM I/O BASE ADDRESS
0018      T.AB    EQU PTMAB
0020      PTMCD   EQU 32               ;SONAR C&D TIMER OFFSET FROM I/O BASE ADDRESS
0020      T.CD    EQU PTMCD
0028      PTHV    EQU 40               ;VSW DRIVE/TIC TIMER OFFSET FROM I/O BASE ADDRESS
0028      T.V     EQU PTHV
0030      PTMF    EQU 48               ;FRONT WHEEL TIMER OFFSET FROM I/O BASE ADDRESS
0030      T.F     EQU PTMF
0038      PTML    EQU 56               ;LEFT WHEEL TIMER OFFSET FROM I/O BASE ADDRESS
0038      T.L     EQU PTML
0040      PTHR    EQU 64               ;RIGHT WHEEL TIMER OFFSET FROM I/O BASE ADDRESS
0040      T.R     EQU PTHR
;
;
0048      PIAAB   EQU 72               ;SONAR A&B TRANSDUCER SELECT PIA I/O OFFSET
0048      P.AB    EQU PIAAB
0050      PIACD   EQU 80               ;SONAR C&D TRANSDUCER SELECT PIA I/O OFFSET
0050      P.CD    EQU PIACD
;
;

```

0001	A0	EQU 1	; MASK BIT TO SELECT SONAR TRANSDUCER A0
0002	A1	EQU 2	; MASK BIT TO SELECT SONAR TRANSDUCER A1
0004	A2	EQU 4	; MASK BIT TO SELECT SONAR TRANSDUCER A2
0008	A3	EQU 8	; MASK BIT TO SELECT SONAR TRANSDUCER A3
0010	A4	EQU 16	; MASK BIT TO SELECT SONAR TRANSDUCER A4
0020	A5	EQU 32	; MASK BIT TO SELECT SONAR TRANSDUCER A5
0040	A6	EQU 64	; MASK BIT TO SELECT SONAR TRANSDUCER A6
0080	A7	EQU 128	; MASK BIT TO SELECT SONAR TRANSDUCER A7
0001	B0	EQU 1	; MASK BIT TO SELECT SONAR TRANSDUCER B0
0002	B1	EQU 2	; MASK BIT TO SELECT SONAR TRANSDUCER B1
0004	B2	EQU 4	; MASK BIT TO SELECT SONAR TRANSDUCER B2
0008	B3	EQU 8	; MASK BIT TO SELECT SONAR TRANSDUCER B3
0010	B4	EQU 16	; MASK BIT TO SELECT SONAR TRANSDUCER B4
0020	B5	EQU 32	; MASK BIT TO SELECT SONAR TRANSDUCER B5
0040	B6	EQU 64	; MASK BIT TO SELECT SONAR TRANSDUCER B6
0080	B7	EQU 128	; MASK BIT TO SELECT SONAR TRANSDUCER B7
0001	C0	EQU 1	; MASK BIT TO SELECT SONAR TRANSDUCER C0
0002	C1	EQU 2	; MASK BIT TO SELECT SONAR TRANSDUCER C1
0004	C2	EQU 4	; MASK BIT TO SELECT SONAR TRANSDUCER C2
0008	C3	EQU 8	; MASK BIT TO SELECT SONAR TRANSDUCER C3
0010	C4	EQU 16	; MASK BIT TO SELECT SONAR TRANSDUCER C4
0020	C5	EQU 32	; MASK BIT TO SELECT SONAR TRANSDUCER C5
0040	C6	EQU 64	; MASK BIT TO SELECT SONAR TRANSDUCER C6
0080	C7	EQU 128	; MASK BIT TO SELECT SONAR TRANSDUCER C7
0001	D0	EQU 1	; MASK BIT TO SELECT SONAR TRANSDUCER D0
0002	D1	EQU 2	; MASK BIT TO SELECT SONAR TRANSDUCER D1
0004	D2	EQU 4	; MASK BIT TO SELECT SONAR TRANSDUCER D2
0008	D3	EQU 8	; MASK BIT TO SELECT SONAR TRANSDUCER D3
0010	D4	EQU 16	; MASK BIT TO SELECT SONAR TRANSDUCER D4
0020	D5	EQU 32	; MASK BIT TO SELECT SONAR TRANSDUCER D5
0040	D6	EQU 64	; MASK BIT TO SELECT SONAR TRANSDUCER D6
0080	D7	EQU 128	; MASK BIT TO SELECT SONAR TRANSDUCER D7
	;		
	;		
0000	ACIASTAT	EQU 0	; OFFSET FROM ACIA BASE FOR STATUS REGISTER
0000	A.S	EQU ACIASTAT	
0000	ACTIACR	EQU 0	; OFFSET FROM ACIA BASE FOR CONTROL REGISTER
0000	A.C	EQU ACTIACR	
0001	ACIATX	EQU 1	; OFFSET FROM ACIA BASE FOR TRANSMIT REGISTER
0001	A.TX	EQU ACIATX	
0001	ACIARX	EQU 1	; OFFSET FROM ACIA BASE FOR RECEIVE REGISTER
0001	A.RX	EQU ACIARX	
	;		
	;		
0001	PTMSTAT	EQU 1	; OFFSET FROM PTM BASE FOR STATUS REGISTER
0001	T.S	EQU PTMSTAT	
	;		
	;		
0000	PTMCR1	EQU 0	; OFFSET FROM PTM BASE FOR TIMER 1 CONTROL REGISTER
0000	T.C1	EQU PTMCR1	
0001	PTMCR2	EQU 1	; OFFSET FROM PTM BASE FOR TIMER 2 CONTROL REGISTER
0001	T.C2	EQU PTMCR2	

```

0000      PTMCR3 EQU 0      ;OFFSET FROM PTM BASE FOR TIMER 3 CONTROL REGISTER
0000      T.C3   EQU PTMCR3
;
;
0002      T.LATCH1 EQU 2    ;PTM COUNTER LATCH FOR TIMER 1
0004      T.LATCH2 EQU 4    ;PTM COUNTER LATCH FOR TIMER 2
0006      T.LATCH3 EQU 6    ;PTM COUNTER LATCH FOR TIMER 3
;
;
0002      T.CNT1  EQU 2    ;PTM COUNTER COUNT FOR TIMER 1
0004      T.CNT2  EQU 4    ;PTM COUNTER COUNT FOR TIMER 2
0006      T.CNT3  EQU 6    ;PTM COUNTER COUNT FOR TIMER 3
;
;
0001      PIACRA  EQU 1    ;PIA A CONTROL REGISTER OFFSET FROM PIA BASE
0001      P.CRA   EQU PIACRA
0003      PIACRB  EQU 3    ;PIA B CONTROL REGISTER OFFSET FROM PIA BASE
0003      P.CRB   EQU PIACRB
0001      PIACRC  EQU 1    ;PIA C CONTROL REGISTER OFFSET FROM PIA BASE
0001      P.CRC   EQU PIACRC
0003      PIACRD  EQU 3    ;PIA D CONTROL REGISTER OFFSET FROM PIA BASE
0003      P.CRD   EQU PIACRD
;
;
0001      PIASTATA EQU 1    ;PIA A STATUS REGISTER OFFSET FROM PIA BASE
0001      P.SRA   EQU PIASTATA
0003      PIASTATB EQU 3    ;PIA B STATUS REGISTER OFFSET FROM PIA BASE
0003      P.SRB   EQU PIASTATB
0001      PIASTATC EQU 1    ;PIA C STATUS REGISTER OFFSET FROM PIA BASE
0001      P.SRC   EQU PIASTATC
0003      PIASTATD EQU 3    ;PIA D STATUS REGISTER OFFSET FROM PIA BASE
0003      P.SRD   EQU PIASTATD
;
;
0000      PIADDA  EQU 0    ;PIA A DATA DIRECTION REGISTER OFFSET FROM PIA BASE
0000      P.DDA   EQU PIADDA
0002      PIADDB  EQU 2    ;PIA B DATA DIRECTION REGISTER OFFSET FROM PIA BASE
0002      P.DDB   EQU PIADDB
0000      PIADDC  EQU 0    ;PIA C DATA DIRECTION REGISTER OFFSET FROM PIA BASE
0000      P.DDC   EQU PIADDC
0002      PIADDD  EQU 2    ;PIA D DATA DIRECTION REGISTER OFFSET FROM PIA BASE
0002      P.DDD   EQU PIADDD
;
;
0000      PIAPA   EQU 0    ;PIA A PERIPHERAL REGISTER OFFSET FROM PIA BASE
0000      P.PRA   EQU PIAPA
0002      PIAPB   EQU 2    ;PIA B PERIPHERAL REGISTER OFFSET FROM PIA BASE
0002      P.PRBB  EQU PIAPB
0000      PIAPC   EQU 0    ;PIA C PERIPHERAL REGISTER OFFSET FROM PIA BASE
0000      P.PRC   EQU PIAPC
0002      PIAPD   EQU 2    ;PIA D PERIPHERAL REGISTER OFFSET FROM PIA BASE
0002      P.PRDD  EQU PIAPD

```

SYSTEM RAM USAGE EQUATE AREA

```

;
;
;
BE80 CRACIAT EQU OSRAM+080H ;COPY OF CONTROL REGISTER BYTE FOR ACIAT
BE81 CRACIAX EQU OSRAM+081H ;COPY OF CONTROL REGISTER BYTE FOR ACIAX
BE82 CRACIAL EQU OSRAM+082H ;COPY OF CONTROL REGISTER BYTE FOR ACIAL
;
;
BE83 CRPTMAB1 EQU OSRAM+083H ;COPY OF CONTROL REGISTER BYTE FOR PTHAB1
BE84 CRPTMAB2 EQU OSRAM+084H ;COPY OF CONTROL REGISTER BYTE FOR PTHAB2
BE85 CRPTMAB3 EQU OSRAM+085H ;COPY OF CONTROL REGISTER BYTE FOR PTHAB3
BE86 CRPTMCD1 EQU OSRAM+086H ;COPY OF CONTROL REGISTER BYTE FOR PTMCD1
BE87 CRPTMCD2 EQU OSRAM+087H ;COPY OF CONTROL REGISTER BYTE FOR PTMCD2
BE88 CRPTMCD3 EQU OSRAM+088H ;COPY OF CONTROL REGISTER BYTE FOR PTMCD3
BE89 CRPTHV1 EQU OSRAM+089H ;COPY OF CONTROL REGISTER BYTE FOR PTHV1
BE8A CRPTHV2 EQU OSRAM+08AH ;COPY OF CONTROL REGISTER BYTE FOR PTHV2
BE8B CRPTHV3 EQU OSRAM+08BH ;COPY OF CONTROL REGISTER BYTE FOR PTHV3
BE8C CRPTHF1 EQU OSRAM+08CH ;COPY OF CONTROL REGISTER BYTE FOR PTHF1
BE8D CRPTHF2 EQU OSRAM+08DH ;COPY OF CONTROL REGISTER BYTE FOR PTHF2
BE8E CRPTHF3 EQU OSRAM+08EH ;COPY OF CONTROL REGISTER BYTE FOR PTHF3
BE8F CRPTML1 EQU OSRAM+08FH ;COPY OF CONTROL REGISTER BYTE FOR PTML1
BE90 CRPTML2 EQU OSRAM+090H ;COPY OF CONTROL REGISTER BYTE FOR PTML2
BE91 CRPTML3 EQU OSRAM+091H ;COPY OF CONTROL REGISTER BYTE FOR PTML3
BE92 CRPTMR1 EQU OSRAM+092H ;COPY OF CONTROL REGISTER BYTE FOR PTMR1
BE93 CRPTMR2 EQU OSRAM+093H ;COPY OF CONTROL REGISTER BYTE FOR PTMR2
BE94 CRPTMR3 EQU OSRAM+094H ;COPY OF CONTROL REGISTER BYTE FOR PTMR3
;
;
BE95 CRPIAA EQU OSRAM+095H ;COPY OF CONTROL REGISTER BYTE FOR PIAA
BE96 CRPIAB EQU OSRAM+096H ;COPY OF CONTROL REGISTER BYTE FOR PIAB
BE97 CRPIAC EQU OSRAM+097H ;COPY OF CONTROL REGISTER BYTE FOR PIAC
BE98 CRPIAD EQU OSRAM+098H ;COPY OF CONTROL REGISTER BYTE FOR PIAD
;
;
BE99 BCPTMAB1 EQU OSRAM+099H ;BINARY COUNT PRELOAD FOR PTHAB1
BE9B BCPTMAB2 EQU OSRAM+09BH ;BINARY COUNT PRELOAD FOR PTHAB2
BE9D BCPTMAB3 EQU OSRAM+09DH ;BINARY COUNT PRELOAD FOR PTHAB3
BE9F BCPTMCD1 EQU OSRAM+09FH ;BINARY COUNT PRELOAD FOR PTMCD1
BEA1 BCPTMCD2 EQU OSRAM+0A1H ;BINARY COUNT PRELOAD FOR PTMCD2
BEA3 BCPTMCD3 EQU OSRAM+0A3H ;BINARY COUNT PRELOAD FOR PTMCD3
BEA5 BCPTHV1 EQU OSRAM+0A5H ;BINARY COUNT PRELOAD FOR PTHV1
BEA7 BCPTHV2 EQU OSRAM+0A7H ;BINARY COUNT PRELOAD FOR PTHV2
BEA9 BCPTHV3 EQU OSRAM+0A9H ;BINARY COUNT PRELOAD FOR PTHV3
BEAB BCPTHF1 EQU OSRAM+0ABH ;BINARY COUNT PRELOAD FOR PTHF1
BEAD BCPTHF2 EQU OSRAM+0ADH ;BINARY COUNT PRELOAD FOR PTHF2
BEAF BCPTHF3 EQU OSRAM+0AFH ;BINARY COUNT PRELOAD FOR PTHF3
BEB1 BCPTML1 EQU OSRAM+0B1H ;BINARY COUNT PRELOAD FOR PTML1
BEB3 BCPTML2 EQU OSRAM+0B3H ;BINARY COUNT PRELOAD FOR PTML2
BEB5 BCPTML3 EQU OSRAM+0B5H ;BINARY COUNT PRELOAD FOR PTML3

```

```

BEB7      BCPTMR1 EQU OSRAM+0B7H      ;BINARY COUNT PRELOAD FOR PTHR1
BEB9      BCPTMR2 EQU OSRAM+0B9H      ;BINARY COUNT PRELOAD FOR PTHR2
BEBB      BCPTMR3 EQU OSRAM+0BBH      ;BINARY COUNT PRELOAD FOR PTHR3
;
;
BEBD      SONARSLA EQU OSRAM+0BDH      ;SONAR SELECT BYTE WRITTEN TO PIA A
BEBD      SSLA EQU SONARSLA
BEDE      SONARSLB EQU OSRAM+0BEH      ;SONAR SELECT BYTE WRITTEN TO PIA B
BEDE      SSLB EQU SONARSLB
BEBF      SONARSLC EQU OSRAM+0BFH      ;SONAR SELECT BYTE WRITTEN TO PIA C
BEBF      SSLC EQU SONARSLC
BEC0      SONARSLD EQU OSRAM+0C0H      ;SONAR SELECT BYTE WRITTEN TO PIA D
BEC0      SSLD EQU SONARSLD
;
;
BEC1      SONARA EQU OSRAM+0C1H      ;LAST SONAR A READING
BEC2      SONARB EQU OSRAM+0C2H      ;LAST SONAR B READING
BEC3      SONARC EQU OSRAM+0C3H      ;LAST SONAR C READING
BEC4      SONARD EQU OSRAM+0C4H      ;LAST SONAR D READING
;
;
BEC5      SONTIME EQU OSRAM+0C5H      ;TIC TIME OF LAST SONAR READING
;
BEC7      MORETIC EQU OSRAM+0C7H      ;JUMP VECTOR FOR EXTENDED TIC INTERRUPT ROUTINE
;
BECA      TIMEZERO EQU OSRAM+0CAH      ;TIME ZERO FROM DRIVE COMPUTER (15 BCD LS NIBBLES)
;
BED9      TICTIME EQU OSRAM+0D9H      ;ONE TENTH SECOND TIC TIME COUNT SINCE TIME ZERO
;
BEDB      IOOFFSET EQU OSRAM+0DBH      ;OFFSET INTO I/O AREA FOR PORT INITIALIZATION
;
BEDC      POWERUP EQU OSRAM+0DCH      ;SET TO 40 IF POWER UP NOT COMPLETE ELSE 55
;
BEDD      RAMSIZEL EQU OSRAM+0DDH      ;LOWER LIMIT OF RAM IN SYSTEM
;
BEDF      RAMSIZEH EQU OSRAM+0DFH      ;HIGH LIMIT OF RAM IN SYSTEM
;
BEE1      SONCHANGE EQU OSRAM+0E1H      ;CHANGE SELECTED SONARS IF 00 ELSE INTERRUPT
;HANDLER SETS THIS BYTE TO 055H
;NEXT SONAR SELECT BYTE WRITTEN TO PIA A
BEE2      SONNEXA EQU OSRAM+0E2H      ;NEXT SONAR SELECT BYTE WRITTEN TO PIA A
BEE2      NSSLA EQU SONNEXA
BEE3      SONNEXB EQU OSRAM+0E3H      ;NEXT SONAR SELECT BYTE WRITTEN TO PIA B
BEE3      NSSLB EQU SONNEXB
BEE4      SONNEXC EQU OSRAM+0E4H      ;NEXT SONAR SELECT BYTE WRITTEN TO PIA C
BEE4      NSSLC EQU SONNEXC
BEE5      SONNEXD EQU OSRAM+0E5H      ;NEXT SONAR SELECT BYTE WRITTEN TO PIA D
BEE5      NSSLD EQU SONNEXD
BEE6      TICTEMP0 EQU OSRAM+0E6H      ;TEMPORARY REGISTER FOR TIC INTERRUPT
BEE8      TICTEMP1 EQU OSRAM+0E8H      ;TEMPORARY REGISTER FOR TIC INTERRUPT
BEEA      TICTEMP2 EQU OSRAM+0EAH      ;TEMPORARY REGISTER FOR TIC INTERRUPT
BEEC      TICTEMP3 EQU OSRAM+0ECH      ;TEMPORARY REGISTER FOR TIC INTERRUPT
;
;

```



```

BFD3      COUNT      EQU  OSRAM+01D3H
BFD4      CKSUM      EQU  OSRAM+01D4H
BFD5      TEMP0      EQU  OSRAM+01D5H
BFD7      TEMP1      EQU  OSRAM+01D7H
BFD9      TEMP2      EQU  OSRAM+01D9H
BFD8      TEMP3      EQU  OSRAM+01DBH
BFD0      TEMP4      EQU  OSRAM+01DDH
BFD6      TEMP5      EQU  OSRAM+01DFH
BFE1      TEMP6      EQU  OSRAM+01E1H
BFE3      TEMP7      EQU  OSRAM+01E3H
BFE5      MYFLAG0    EQU  OSRAM+01E5H
BFE6      MYFLAG1    EQU  OSRAM+01E6H
BFE7      SYSFLAG    EQU  OSRAM+01E7H
BFE8      ECHO      EQU  OSRAM+01E8H
BFE9      TCOUNT   EQU  OSRAM+01E9H
BFEA      CREG      EQU  OSRAM+01EAH
BFEB      BREG      EQU  OSRAM+01EBH
BFEC      AREG      EQU  OSRAM+01ECH
BFED      XREG      EQU  OSRAM+01EDH
BFEF      PREG      EQU  OSRAM+01EFH
BFF1      SREG      EQU  OSRAM+01F1H
BFF3      USWI      EQU  OSRAM+01F3H
BFF5      ACIAI     EQU  OSRAM+01F5H
BFF7      IPOVEC    EQU  OSRAM+01F7H
BFFA      SWIVC     EQU  OSRAM+01FAH
BFFD      MWIVC     EQU  OSRAM+01FDH
A000      MIOV      EQU  0A000H
A002      MBEGA     EQU  0A002H
A004      MENDA     EQU  0A004H
A005      MENDA1    EQU  0A005H
A006      MNIO      EQU  0A006H
A008      MSP       EQU  0A008H
A00A      MCKSM     EQU  0A00AH
A00B      MBYTECT   EQU  0A00BH
A00C      MXHI      EQU  0A00CH
A00D      MXLOW     EQU  0A00DH
A00E      MTEMP     EQU  0A00EH
A00F      MTW       EQU  0A00FH
A010      MTK1      EQU  0A010H
A011      MRCUNT    EQU  0A011H
A012      MXTMP     EQU  0A012H
A042      MSTACK    EQU  0A042H
0000      MACIA     EQU  ACIAI
BFF5      MACIAI    EQU  ACIAI
;
; THIS AREA FOR SPECIAL SYMBOLIC EQUATES
;
0000      XZERO     EQU  0000H      ;LOADS ZERO INTO INDEX REGISTER
;
0000      END

```

No error(s).

SYMBOL TABLE FOR FILE NAVDEF.A

A.C	0000	A.L	0010	A.RX	0001	A.S	0000
A.T	0000	A.TX	0001	A.X	0008	A0	0001
A1	0002	A2	0004	A3	0008	A4	0010
A5	0020	A6	0040	A7	0080	ACIACR	0000
ACIAI	BFF5	ACIAL	0010	ACIARX	0001	ACIASTAT	0000
ACIAT	0000	ACIATX	0001	ACIAX	0008	ADDH	BFCE
ADDL	BFCC	ADR	BFCA	AREG	BFEC	B0	0031
B1	0002	B2	0004	B3	0008	B4	0010
B5	0020	B6	0040	B7	0080	BCPTMAB1	BE99
BCPTMAB2	BE98	BCPTMAB3	BE9D	BCPTMCD1	BE9F	BCPTMCD2	BEA1
BCPTMCD3	BEA3	BCPTMF1	BEAB	BCPTMF2	BEAD	BCPTMF3	BEAF
BCPTML1	BEB1	BCPTML2	BEB3	BCPTML3	BEDE	BCPTMR1	BEB7
BCPTMR2	BEB9	BCPTMR3	BEB8	BCPTMV1	BEA5	BCPTMV2	BEA7
BCPTMV3	BEA9	BOS	BE7F	BREG	BFEB	BUF	BF80
BUFEND	BFC7	BUFPTR	BFD0	C0	0001	C1	0002
C2	0004	C3	0008	C4	0010	C5	0020
C6	0040	C7	0080	CKSUM	BFD4	COLD	BF05
COUNT	BFD3	CRACIAL	BE82	CRACIAT	BE80	CRACIAX	BE81
CREG	BFEA	CRPIAA	BE95	CRPIAB	BE96	CRPIAC	BE97
CRPIAD	BE98	CRPTMAB1	BE83	CRPTMAB2	BE84	CRPTMAB3	BE85
CRPTMCD1	BE86	CRPTMCD2	BE87	CRPTMCD3	BE88	CRPTMF1	BE8C
CRPTMF2	BE8D	CRPTMF3	BE8E	CRPTML1	BE8F	CRPTML2	BE90
CRPTML3	BE91	CRPTMR1	BE92	CRPTMR2	BE93	CRPTMR3	BE94
CRPTMV1	BE89	CRPTMV2	BE8A	CRPTMV3	BE8B	D0	0001
D1	0002	D2	0004	D3	0008	D4	0010
D5	0020	D6	0040	D7	0080	ECHO	BFEB
FWCOUNT	BEF7	INTHASK	BEEE	I0	C000	IOFFSET	BEDE
IRQVEC	BFF7	LKSONTMP	BF7C	LSXTEMP	BF7E	LWCOUNT1	BEFD
LWCOUNT2	BEFF	LWMOD1	BF03	LWMOD2	BF04	MACIA	0000
MACIAI	BFF5	MBEGA	A002	MBYTECT	A00B	MCKSM	A00A
MENDA	A004	MENDA1	A005	MIOV	A000	MMCONT	A011
MNIO	A006	MORETIC	BEC7	MSP	A008	MSTACK	A042
MTEMP	A00E	MTW	A00F	MTW1	A010	MXHI	A00C
MXLOW	A00D	NXTEMP	A012	MYFLAG0	BFES	MYFLAG1	BFE6
MNIVEC	BFFD	NSSLA	BEE2	NSSLB	BEE3	NSSLC	BEE4
NSSLD	BEE5	ODESSEY	BF0B	OFFSET	BFC8	OSEMOD	BF01
OSEREG	BEF7	OSRAM	BE00	P.AB	0048	P.CD	0050
P.CRA	0001	P.CRB	0003	P.CRC	0001	P.CRD	0003
P.DDA	0000	P.DDE	0002	P.DDC	0000	P.DDD	0002
P.PRA	0000	P.PRB	0002	P.PRC	0000	P.PRD	0002
P.SRA	0001	P.SRB	0003	P.SRC	0001	P.SRD	0003
PIAAB	0048	PIACD	0050	PIACRA	0001	PIACRB	0003
PIACRC	0001	PIACRD	0003	PIADDA	0000	PIADDB	0002
PIADDC	0000	PIADDD	0002	PIAPA	0000	PIAPB	0002
PIAPC	0000	PIAPD	0002	PIASTATA	0001	PIASTATB	0003
PIASTATC	0001	PIASTATD	0003	POWERUP	BEDC	PREG	BFEF
PTMAB	0018	PTMCD	0020	PTMCR1	0000	PTMCR2	0001
PTMCR3	0000	PTMF	0030	PTML	0038	PTMR	0040
PTKSTAT	0001	PTMV	0028	RAMSIZE1	BEDF	RAMSIZE2	BED0

RECTYP	BFD2	RWCOUNT1	BEF9	RWCOUNT2	BEFB	RWMOD1	BF01
SONMOD2	BF02	SONARA	BEC1	SONARB	BEC2	SONARC	BEC3
SONARD	BEC4	SONARSLA	BEBD	SONARSLB	BEBE	SONARSLC	BEBF
SONARSLD	BEC0	SONCHANG	BEE1	SONDATRA	BEF0	SONDATRB	BEF2
SONDATRC	BEF4	SONDATRD	BEF6	SONDATSA	BEF7	SONDATSB	BEF1
SONDATSC	BEF3	SONDATSD	BEF5	SONEXA	BEE2	SONEXB	BEE3
SONNEXC	BEE4	SONNEXD	BEE5	SONTIME	BEC5	SREG	BFF1
SSLA	BEBD	SSLB	BEBE	SSLC	BEBF	SSLD	BEC0
SMIVEC	BFFA	SYSFLAG	BFE7	T.AB	0018	T.C1	0000
T.C2	0001	T.C3	0000	T.CD	0020	T.CNT1	0002
T.CNT2	0004	T.CNT3	0006	T.F	0030	T.L	0038
T.LATCH1	0002	T.LATCH2	0004	T.LATCH3	0006	T.R	0040
T.S	0001	T.V	0028	TCOUNT	BFE9	TEMP0	BFD5
TEMP1	BFD7	TEMP2	BFD9	TEMP3	BFD8	TEMP4	BFD0
TEMP5	BFD7	TEMP6	BFE1	TEMP7	BFE3	TICTEMP0	BEE6
TICTEMP1	BEF8	TICTEMP2	BEEA	TICTEMP3	BEEC	TICTIME	BED9
TIMEZERO	BECA	TUSRAM	BC00	USRSTAK	BE00	USWI	BFF3
YARM	BF08	XREG	BFE0	XZERO	0000		

```
*****
*
* APPENDIX E *
*
*
*****
```

```
FILE: DRIVEDEF.A
```

```
PARS-1 DRIVE COMPUTER DEFINITIONS
```

```
THE DRIVE COMPUTER USES THE VIRTUAL DEVICES
MENOS UPGRADE FOR THE HEATH HERO COMPUTER. AS SUCH,
THE CPU IS A MOTOROLA 6801 AND SYSTEM RAM USAGE IS
SLIGHTLY DIFFERENT FROM THE STANDARD HERO COMPUTER.
THE BAUD RATE FOR THE 6801 SERIAL COMMUNICATION INTERFACE
IS 300 BAUD WHEN POWERING UP IN LILBUG MODE AND 9600
BAUD WHEN IN MENOS MODE. THE ORIGINAL BAUD RATE
FOR MENOS WAS 300. THE 9600 BAUD RATE WAS OBTAINED BY
BURNING A NEW ROM (U301) FOR THE MENOS UPGRADE BOARD
AND CHANGING THE FOLLOWING ROM LOCATIONS
```

```
0FEE9H 0FF06H 0FF91H
```

```
WITH A NEW BAUD RATE DIVISOR BYTE:
```

```
05 FOR 9600 BAUD
```

```
06 FOR 1200 BAUD
```

```
07 FOR 300 BAUD
```

```
0000
```

```
ORG 0000H
```

```
;RAM ALLOCATIONS FOR MODIFIED HERO (0000-03FF)
```

```
;Version 1.1C.
```

```
;Written by A. H. Ballard 10/22/33
```

```
;Version 2.
```

```
;Written by A. H. Ballard 1/14/84
```

```

; The original HERO ROM monitor (version 1.0) made use
; of the first 63 bytes of the 4K RAM for status data and
; jump vectors, and the top 287 bytes of RAM for stacks
; and scratchpad areas. The central 3746 bytes (003F to
; 0EE0) were left available for user programs. Version
; 1.1 of the HERO ROM used another 2 bytes in high RAM.
; The modified ROM produced by Virtual Devices reserves
; the first 32 bytes in ROM for use as control and status
; registers for a new 6801 microprocessor. The original
; 63 bytes in RAM were moved up by 32 bytes (20 Hex added
; to all addresses). In addition, the Virtual Devices
; modification (Version 10) uses 2 bytes in high RAM as a
; buffer for serial communications.

```

```

; Immediately after a cold start or a warm restart,
; certain of these RAM locations are initialized to
; default values. See the file MHINI1.A for details
; of RAM initialization in the HERO robot, as modified by
; Virtual Devices.

```

```

;Current overall allocation of RAM:

```

```

; Low RAM used by Mod HERO      75 bytes (0000-005E)
; User memory available        3710 bytes (005F-0EDC)
; High RAM used by Mod HERO    291 bytes (0EDD-03FF)

```

```

;Reserved bytes in low RAM:

```

```

;6801 control and status registers:

```

```

0000      DDR1      RMB 1      ;Port 1 data direction register
;
;          0 = input
;          1 = output
;
0001      DDR2      RMB 1      ;Port 2 data direction register
;
;          0 = input
;          1 = output
;
;
0002      DR1       RMB 1      ;Port 1 data register
;
;          Bits 7,6 = select memory map
;
;          00 = (not used)
;          01 = SYSROM $6000, SYSRAM $E000
;          10 = SYSRAM $6000, HROM $E000
;          11 = SYSRAM $6000, SYSROM $E000

```

```

;
; Bit 5 = green LED (0/1 = OFF/ON)
; Bit 4 = select memory bank 0/1
; Bit 3 = radio (0/1 = RCV/XMT)
; Bit 2 = timer 3 output
; Bit 1 = timer 2 output
; Bit 0 = timer 2 input
;
0003 DR2 RMB 1 ;Port 2 data register
;
; Bits 7,6,5 = 6801 mode (R/O)
; Bit 4 = serial comm output
; Bit 3 = serial comm input
; Bit 2 = clock for serial comm
; Bit 1 = timer 1 output
; Bit 0 = timer 1 input
;
;
;
0004 ORG $0004
;
0004 DDR3 RMB 1 ;Port 3 data direction register (not used)
;
0004 DR2CPY EQU $04 ; COPY OF Port 2 data register
;
; CRITICAL ADDRESS!!!!!!!!!!!!!!
;
;
;
0005 ORG $0005
;
;
0005 DDR4 RMB 1 ;Port 4 data direction register
;
; Set 1's for address output
;
;
;
0006 ORG $0006
;
0006 DR3 RMB 1 ;Port 3 data register (not used)
;
0006 DDR1CPY EQU $06 ; COPY OF Port 1 data direction register
;
;
;
0007 ORG $0007
;
0007 DR4 RMB 1 ;Port 4 data register (not used)
;

```

```

:
:
0008          ORG 10008
:
0008          TCSR   RMB 1   ;Timer 1 control and status register
:
:           ; Bit 7 = ICF, input capture flag (R/O)
:           ; Bit 6 = OCF, output compare flag (R/O)
:           ; Bit 5 = TOF, timer overflow flag (R/O)
:           ; Bit 4 = EICI, enable input capture interrupts
:           ; Bit 3 = EOCI, enable output compare interrupts
:           ; Bit 2 = ETOI, enable timer overflow interrupts
:           ; Bit 1 = IEDG, input edge polarity (0=L, 1=LH)
:           ; Bit 0 = OLVL, output level select (0=L, 1=H)
:
0009          CNTR   RMB 2   ;16-bit CPU counter register (R/O)
:
:
000B          OCR1   RMB 2   ;16-bit output compare register 1
:
:
000D          ICR1   RMB 2   ;16-bit input capture register 1 (R/O)
:
:
:
000F          ORG 1000F
:
000F          CR3    RMB 1   ;Port 3 control register (not used)
000F          DRICPY EQU 10F   ; COPY OF Port 1 data register
:
:
:
0010          ORG 10010
:
0010          RMCR   RMB 1   ;SCI rate and mode control register
:
:           ; Bits 7-4 = (not used)
:
:           ; Bits 3,2 = format and clock control
:
:           ; 00 = Bi-phase, internal clock, P22 not used
:           ; 01 = NRZ, internal clock, P22 not used
:           ; 10 = NRZ, internal clock, P22 is clock output
:           ; 11 = NRZ, external clock, P22 is clock input
:
:           ; Bits 1,0 = baud rate select
:
:           ; 00 = 76800 bps
:           ; 01 = 9600 bps
:           ; 10 = 1200 bps
:           ; 11 = 300 bps
:
:

```

```

0011      TRCS   RMB 1 ;SCI transmit/receive control/status
;
; Bit 7 = RDRF, receive data register full flag (R/O)
; Bit 6 = ORFE, overrun/framing error flag (R/O)
; Bit 5 = TDRE, transmit data register empty flag (R/O)
; Bit 4 = RIE, receiver interrupt enable
; Bit 3 = RE, receiver enable
; Bit 2 = TIE, transmitter interrupt enable
; Bit 1 = TE, transmitter enable
; Bit 0 = WU, enable wake-up on next message
;
0012      RDR    RMB 1 ;SCI receive data register
;
0013      TDR    RMB 1 ;SCI transmit data register
;
0014      RAMC   RMB 1 ;RAM control register
;
; Bit 7 = STBY, set to monitor voltage (0/1=LO/HI)
; Bit 6 = RAME, 0/1=enable/disable on-chip RAM ($80FF)
; Bits 5-0 = (not used)
;
;
;
0015      ORG $0015
;
;Additional registers for 6801U4 version:
;
; THE FOLLOWING ARE NOT IMPLEMENTED IN THE BASIC 6801 OR 6301
; THESE ARE BEING RESERVED FOR THE POTENTIAL USE OF THE 6801U4
;
0015      ACNT   RMB 2 ;Alternate counter address
0017      TCR1   RMB 1 ;Timer control register 1
0018      TCR2   RMB 1 ;Timer control register 2
0019      TSR    RMB 1 ;Timer status register
001A      OCR2   RMB 2 ;Output compare register 2
001C      OCR3   RMB 2 ;Output compare register 3
001E      ICR2   RMB 2 ;Input capture register 2
;
;
;
0020      ORG $0020
;

```

```

;HERO status data:
;
0020      mpos      EQU #
0020      EXTPOS   RMB 1 ;Current position of arm extend motor
0021      SHLPOS   RMB 1 ;Current position of shoulder motor
0022      ROTPOS   RMB 1 ;Current position of wrist rotate motor
0023      PVTPOS   RMB 1 ;Current position of wrist pivot motor
0024      GRPPOS   RMB 1 ;Current position of gripper motor
0025      HEDPOS   RMB 1 ;Current position of head motor
0026      STRPOS   RMB 1 ;Current position of steering motor
0027      DRVPOS   RMB 2 ;Spoke count for base motor command
0029      DRVODM   RMB 2 ;Odometer spoke count for base motor
;
;
002B      ACTSTAT  RMB 1 ;Activity status byte
;
;      Bits 7-5 = (not used)
;      Bit 4 = base speed ramping
;      Bit 3 = speech active
;      Bit 2 = arm/head motors active
;      Bit 1 = steering motor active
;      Bit 0 = base motor active
;
;
002C      ABTSTAT  RMB 1 ;Abort request status byte
;
;      Bits 7-4 = (not used)
;      Bit 3 = abort speech
;      Bit 2 = abort arm/head motors
;      Bit 1 = abort steering motor
;      Bit 0 = abort base motor
;
;
002D      SLEEPER  RMB 2 ;Sleep count, 10 sec steps
002F      HUNGRY   RMB 1 ;Low (logic) battery indicator byte
0030      SNRHIT   RMB 1 ;Cum count for detected sonar echoes
0031      SNRRNG   RMB 1 ;Most recently measured sonar range
;
;
;
0032      ORG $0032
;
;User-supplied jump vectors:
;
;      Default (R) = RTS; (SR) = SEC,RTS; (-) = none
;
0032      USRCYCLE RMB 3 ;Customize start of interp cycle      (R)
0035      USRINTRP RMB 3 ;Extend interp command list      (SR)
0038      USRIRQ   RMB 3 ;Customize IRQ handler      (R)
003B      USRCLOCK RMB 3 ;Customize clock IRQ routine (R)
003E      USRSPD   RMB 3 ;Customize drive speed routine (R)
0041      USRLLB   RMB 3 ;New IRC, low logic battery  (SR)

```



```

0EE1      MODE      RMB 1 ;00= native mode, FF=robot mode
          ;
0EE2      PCSAVE   RMB 2 ;User program counter stored here
          ;
0EE4      STRSTP   RMB 12 ;Buffer area for steer stepper motor
0EF0      ARMSTP   RMB 12 ;Buffer area for arm/head steppers
          ;
          ; Format for STRSTP and ARMSTP buffers:
          ;
          ; Byte 0 = STPMASK, mask for output port
          ;
          ; $0F = low nibble
          ; $F0 = high nibble
          ;
          ; Byte 1 = STPSCL, scale factor
          ;
          ; $03 = 4 physical steps per logical step
          ; $07 = 8 physical steps per logical step
          ; $0F = 16 physical steps per logical step
          ; $1F = 32 physical steps per logical step
          ;
          ; Bytes 2,3 = STPPORT, stepper output port
          ;
          ; Bytes 4,5 = STPPOS, address of current position
          ;
          ; Byte 6 = STPLIM, limit switch mask for port $C260
          ;
          ; $24 for shoulder motor
          ; $12 for head motor
          ; $48 for steering motor
          ; $00 for other motors
          ;
          ; Byte 7 = STPTIME, speed divisor (decremented to 0)
          ;
          ; Byte 8 = STPTIME0, speed divisor (fixed)
          ;
          ; Byte 9 = STPSEQ, step pattern sequence select
          ;
          ; $00-03 for forward (start at $00)
          ; $04-07 for reverse (start at $04)
          ;
          ; Bytes 10,11 = STPNO, number of physical steps to go
          ;
          ;
0EFC      CLKTIME  RMB 1 ;8-bit count for 1024 Hz clock
          ;
0EFD      DRVNO    RMB 2 ;Steps to go (DPOS) for base motor
          ;
0EFF      STRPCPY  RMB 1 ;Last byte sent to STRPORT=C260

```

```

0F00      DRVPCPY RMB 1 ;Last byte sent to DRVPORT=C2A0
0F01      DRVPMEM RMB 1 ;New byte to go to DRVPORT=C2A0
0F02      ADRPCPY RMB 1 ;Last byte sent to ADRPORT=C2C0
0F03      PWRPCPY RMB 1 ;Last byte sent to PWRPORT=C2E0
0F04      IRQPCPY RMB 1 ;Last byte sent to IRQPORT=C220
;
0F05      SPSKAREA RMB 16 ;Speech stack, max of 8 addresses
0F15      SPSKFMA RMB 2 ;Location, 1st speech stack entry
0F17      SPSKLEMA RMB 2 ;Location, 8th speech stack entry
0F19      SPSKPTR RMB 2 ;Speech stack pointer saved here
;
0F1B      MTRSPD RMB 1 ;Base motor speed byte stored here
0F1C      STRCTADR RMB 2 ;STRSTP/ARMSTP selection saved here
0F1E      MCB RMB 2 ;Buffer for motor control bytes
0F20      ACTMASK RMB 1 ;Mask bits for ACTSTAT byte
0F21      ACTIVATE RMB 1 ;Buffer for new ACTSTAT bits
0F22      DEST RMB 2 ;Destination address for block move
0F24      SRC RMB 2 ;Source address for block move
0F26      MVALLOP RMB 2 ;Buffer for address of 1st MVALL operand
;
;
;
;
;Used in learn/manual mode only:
;
0F28      REVPOS RMB 2 ;
0F2A      REVADDR RMB 2 ;
0F2C      ADDRPTR RMB 2 ;
0F2E      ADDR RMB 2 ;
0F30      OLDADDR RMB 2 ;
0F32      FRSTADDR RMB 2 ;
0F34      LASTADDR RMB 2 ;
0F36      LRMODE RMB 1 ;
0F37      OLDSLCT RMB 1 ;
0F38      OLDDIR RMB 1 ;
0F39      OLDPOS RMB 1 ;
0F3A      ISOLD RMB 1 ;
0F3B      SLCT RMB 1 ;
0F3C      DIR RMB 1 ;
0F3D      ISARM RMB 1 ;
0F3E      DRVON RMB 1 ;
0F3F      STRGON RMB 1 ;
0F40      ARMON RMB 1 ;
0F41      ARMBACK RMB 1 ;
0F42      ARMSTOP RMB 1 ;
0F43      DELAYTH RMB 2 ;
0F45      TRIGIN RMB 1 ;
0F46      BASEOP RMB 1 ;
0F47      OPCODE RMB 1 ;
0F48      POS RMB 2 ;
0F4A      MTR RMB 1 ;
0F4B      SPD RMB 1 ;

```

```

0F4C      OLDDIS  RMB 2 ;
0F4E      DISLME  RMB 1 ;
0F4F      OLDLME  RMB 1 ;
0F50      XTEMP   RMB 2 ;
;
;Used by IRQ handler only;
;
0F52      STPPTR  RMB 2 ;
0F54      TEMP1   RMB 2 ;
0F56      SPSAVE  RMB 2 ;
;
;Used in executive and interpreter mode;
;
0F58      USRSTK  RMB 64 ;User stack area
0F98      MONSTK  RMB 64 ;Monitor stack area
0FD8      PWRSTK  RMB 8  ;Power-on stack area
0FE0      BKTBL   RMB 12 ;Table of 4 breakpoint vectors
0FEC      BKPNTSTK RMB 2 ;Pointer for breakpoint stack
0FEE      TE0     RMB 2 ;Temporary register, exec mode
0FF0      TE1     RMB 2 ;Temporary register, exec mode
0FF2      DIGADD  RMB 2 ;Address of next LED display digit
0FF4      USERS   RMB 2 ;User's stack pointer
0FF6      SYSSNI  RMB 3 ;Software interrupt vector
0FF9      DSHPTR  RMB 2 ;Digit address for moving dash display
0FFB      DSHDIR  RMB 1 ;Direction of moving dash display
0FFC      TIME1   RMB 2 ;Display time for "HERO 1.x"
0FFE      TIME2   RMB 2 ;Display time for moving dash
;
;Used in executive and interpreter modes;
;
;
;End of 4K RAM
;
;
; CONTROL AND STATUS PORTS -- MEMORY MAPPED PHYSICAL ADDRESSES
;
C220      SNRTMR  EQU %C220 ;SONAR TIMER
C240      SENSE   EQU %C240 ;SENSE INPUT
C260      LIMIT   EQU %C260 ;LIMIT SWITCH INPUT BYTE
C280      TEACHING EQU %C280 ;TEACHING_PNDT (REMOTE) INPUT BYTE
C200      IRQ_PORT EQU %C200 ;IRQ INTERRUPT BYTE INPUT
C220      EXP_OUT_ EQU %C220 ;EXP_OUT_ADDR EXPERIMENTAL BOARD OUTPUT BYTE
C2A0      EXP_IN_A EQU %C2A0 ;EXP_IN_ADDR EXPERIMENTAL BOARD INPUT BYTE
;
;PORT DEFINITIONS FOR HERO ROBOT (%C000-D000)
;
;Version 1.0, 1/16/84, written by A. H. Ballard
;
;
;(6801 ports are defined in HERODEF1.a)

```

```

;Input ports:
;
C003 COL1 EQU %C003 ;Input from keypad column 1
C005 COL2 EQU %C005 ;Input from keypad column 2
C006 COL3 EQU %C006 ;Input from keypad column 3
;
C220 SNRPORT EQU %C220 ;Sonar range data (8 bits)
;
C240 SENSPORT EQU %C240 ;Light/sound intensity (8 bits)
;
C260 LIMPORT EQU %C260 ;Limit switches + miscellaneous
;
; Bit 7 = Cassette tape input
; Bit 6 = Steering motor full CCW
; Bit 5 = Shoulder motor full DOWN
; Bit 4 = Head motor full CCW
; Bit 3 = Steering motor full CW
; Bit 2 = Shoulder motor full UP
; Bit 1 = Head motor full CW
; Bit 0 = Speech board ready for next phoneme
;
C280 REMPORT EQU %C280 ;Remote teach pendant, sleep sw.
;
; Bit 7 = Select base (0) or arm (1) motion
;
; Bits 6,5,4 = rotary selector
;
; If base selected: 000 = stop base drive
;                   001 = drive forward, slow
;                   010 = drive forward, medium
;                   011 = drive forward, fast
;                   100 = (not used)
;                   101 = drive reverse, slow
;                   110 = drive reverse, medium
;                   111 = drive reverse, fast
;
; If arm selected: 000 = (not Used)
;                 001 = select wrist pivot motor
;                 010 = select wrist rotate motor
;                 011 = select gripper motor
;                 100 = (not used )
;                 101 = select shoulder motor
;                 110 = select arm extend motor
;                 111 = select head motor
;
; Bit 3 = 0 for left/down/in/open direction, 1 for OFF
;
; Bit 2 = 0 for right/up/out/close direction, 1 for OFF
;
; Bit 1 = Sleep switch (0 = sleep, 1 = normal)
;
; Bit 0 = Pendant trigger (0 = released, 1 = active)

```

```

;
C2A0      EXPINPUT EQU %C2A0      ;Experiment board input port (8 bits)
;
;Input/output ports:
;
C200      IRGPORT EQU %C200      ;Interrupt request port
;
;   Input = read interrupt flags
;   Output = reset interrupt flags
;
;   Bit 7 = experiment board interrupt
;   Bit 6 = drive wheel spoke sensor
;   Bit 5 = trigger on teach pendant
;   Bit 4 = 1024 Hz clock
;   Bit 3 = low logic battery sensor
;   Bit 2 = low drive battery sensor
;   Bit 1 = motion detector
;   Bit 0 = sonar echo detector
;
C300      CLKPORT EQU %C300      ;Set or read time/date
;
;   Bits 7-4 = Mode select
;
;   0100 = Write
;   0101 = Hold
;   1010 = Read
;   (other codes not used)
;
;   Bits 3-0 = input/output data bus
;
;   Range = 0000-1001 (0-9) except:
;
;       For tens of hours, bit 2 = 0/1 for AM/PM
;       bit 3 = 0/1 for 12/24 hour clock
;       For tens of days, bit 2 = 0/1 for normal/leap year
;
;   Clock digits are selected by bits 3-0 of ADRPORT
;
;Output ports:
;
C16F      DG6ADD EQU %C16F      ;Leftmost display digit
C15F      DG5ADD EQU %C15F
C14F      DG4ADD EQU %C14F
C13F      DG3ADD EQU %C13F
C12F      DG2ADD EQU %C12F
C11F      DG1ADD EQU %C11F      ;Rightmost display digit
;
;   See MHSYM681.A for definition of display symbols
;
;
C220      EXPCPORT EQU %C220     ;Experiment board output port

```

```

C240      SPCHPORT EQU %C240      ;Speech port
;
; Bits 7-6 = pitch select (00-11 for levels 1-4)
; Bits 5-0 = phoneme select (1 of 64)
;
; See MHSYM681.A for definition of phoneme symbols
;
C260      STRPORT EQU %C260      ;Steer and wrist motor port
;
; Bits 7-4 = output step pattern for steer motor
;
; Bits 3-0 = output step pattern for:
;
;           Wrist pivot motor if ARMSEL = 01
;           Wrist rotate motor if ARMSEL = 10
;
; ARMSEL = bits 7,6 of ADRPORT
;
C280      EXTPORT EQU %C280      ;Extend/head/gripper/shoulder port
;
; Bits 7-4 = output step pattern for:
;
;           Arm extend motor if ARMSEL = 01
;           Head motor if ARMSEL = 10
;
; Bits 3-0 = output step pattern for:
;
;           Gripper motor if ARMSEL = 01
;           Shoulder motor if ARMSEL = 10
;
; ARMSEL = bits 7,6 of ADRPORT
;
C2A0      DRVPORT EQU %C2A0      ;Base drive port
;
; Bit 7 = direction (0 = forward, 1 = reverse)
;
; Bits 6-0 = magnitude of speed
;
; $00-3F = zero speed (dead zone)
; $40-FF = actual speed range
;
C2C0      ADRPORT EQU %C2C0      ;Address port
;
; Bits 7-6 = ARMSEL
;
; 01 = select wrist pivot, arm extend, gripper motors
; 10 = select wrist rotate, head, shoulder motors
;      (other codes not used)
;
; Bit 5 = speech strobe (for phoneme code)

```

```

; Bit 4 = (not used)
;
; Bits 3-0 = select real-time clock digit
;
; 0000 = seconds (0-9)
; 0001 = tens of seconds (0-5)
; 0010 = minutes (0-9)
; 0011 = tens of minutes (0-5)
; 0100 = hours (0-9)
; 0101 = tens of hours (0-2)
; 0110 = day of week (0-6)
; 0111 = days (0-9)
; 1000 = tens of days (0-3)
; 1001 = months (0-9)
; 1010 = tens of months (0-1)
; 1011 = years (0-9)
; 1100 = tens of years (0-9)

```

C2E0

```

PWRPORT EQU %C2E0 ;Power control + miscellaneous

```

```

; Bit 7 = Select light (1) or sound (0) sensor
; Bit 6 = Main power (0/1 = OFF/ON)
; Bit 5 = Light/sound sense board power
; Bit 4 = Display board power
; Bit 3 = Speech board power
; Bit 2 = Motion detector power
; Bit 1 = Sonar power
; Bit 0 = Cassette tape output

```

```

;DEFINITION OF DISPLAY, PHONEME, AND OTHER SYMBOLS
; USED WITH HERO ROBOT

```

```

;Version 1.0, 1/16/84, written by A. H. Ballard

```

```

;DISPLAY ( YES

```

```

; The HERO display has 6 digits. Each digit is
; an LED display assembly having 7 segments and a dot
; (decimal point) arranged in the following pattern.

```

—		6	
	SEGMENT	1 5	CODE BIT
—	PATTERN	0	ASSIGNMENT
		2 4	
— .		3 7	

```

;The segments to be lit are identified by individual
;bits in an 8-bit code character, as shown. Adding a
;dot after any character is achieved by adding 80 hex
;to the original display character code.

```

A display character will be designated by preceding it with the ' symbol (accent grave).

HEX NUMBERS

007E	'	EQU \$7E
0030	'1	EQU \$30
006D	'2	EQU \$6D
0079	'3	EQU \$79
0033	'4	EQU \$33
0058	'5	EQU \$58
005F	'6	EQU \$5F
0070	'7	EQU \$70
007F	'8	EQU \$7F
007B	'9	EQU \$7B
0077	'A	EQU \$77
001F	'B	EQU \$1F
004E	'C	EQU \$4E
003D	'D	EQU \$3D
004F	'E	EQU \$4F
0047	'F	EQU \$47

LETTERS

0077	'A	EQU \$77	;Same as hex A
007D	'a	EQU \$7D	
001F	'b	EQU \$1F	;Same as hex B
004E	'c	EQU \$4E	;Same as hex C
000D	'c	EQU \$0D	
003D	'd	EQU \$3D	;Same as hex D
004F	'E	EQU \$4F	;Same as hex E
0047	'F	EQU \$47	;Same as hex F
005E	'g	EQU \$5E	
0037	'	EQU \$37	
0017	'	EQU \$17	
0030	'i	EQU \$30	
003C	'J	EQU \$3C	
000E	'L	EQU \$0E	
0015	'n	EQU \$15	
007E	'O	EQU \$7E	;Same as hex 0
001D	'o	EQU \$1D	
0067	'p	EQU \$67	
0005	'r	EQU \$05	
0058	'S	EQU \$58	
0070	't	EQU \$70	;Same as hex 7
003E	'U	EQU \$3E	
001C	'u	EQU \$1C	
003B	'y	EQU \$3B	

```

;PUNCTUATION
;
0001      'hy      EQU $01      ;Hyphen, dash or minus
0008      ' _      EQU $08      ;Underscore
0009      ' .      EQU $09      ;Dot or period
000A      ' !      EQU $0A      ;Exclamation point
0022      ' "      EQU $22      ;Double quote
0065      ' ?      EQU $65      ;Question mark
0000      ' sp     EQU $00      ;Space or blank
;
;PHONEME CODES
;
;       The speech synthesizer in the HERO accepts 8-bit
;phoneme codes. The lower 6 bits select 1 of 64 coded
;phonemes, while the upper two bits select 1 of 4 pitch
;levels. The basic phoneme codes range from $00 to $3F
;at pitch level 1. To vary the pitch (inflection) to
;get greater naturalness:
;
;       Add $40 to get pitch level 2
;       Add $80 to get pitch level 3
;       Add $C0 to get pitch level 4
;
;The STOP phoneme ($3F) is the only code that should
;never be raised in pitch. Raising it to $BF or $FF
;would change its meaning.
;
;       A phoneme code will be designated by preceding
;it with the ~ symbol (tilde). Phoneme durations in
;milliseconds are shown in parentheses in the comments.
;
0000      ~EH3    EQU $00      ;( 59) as in jack_e_t
0001      ~EH2    EQU $01      ;( 71) as in e_nlist
0002      ~EH1    EQU $02      ;(121) as in h_ea_vy
0003      ~sp     EQU $03      ;( 47) short pause
0004      ~DT     EQU $04      ;( 47) as in bu_tt_er
0005      ~A2     EQU $05      ;( 71) as in m_a_de
0006      ~A1     EQU $06      ;(103) as in m_a_de
0007      ~ZH     EQU $07      ;( 90) as in a_z_ure
0008      ~AH2    EQU $08      ;( 71) as in h_o_nest
0009      ~I3     EQU $09      ;( 55) as in inhib_i_t
000A      ~I2     EQU $0A      ;( 80) as in i_nhibit
000B      ~I1     EQU $0B      ;(121) as in inh_i_bit
000C      ~M      EQU $0C      ;(103) as in m_at
000D      ~N      EQU $0D      ;( 80) as in su_n
000E      ~B      EQU $0E      ;( 71) as in b_ag
000F      ~V      EQU $0F      ;( 71) as in v_an
0010      ~CH     EQU $10      ;( 71) as in ch_ip (~T first)
0011      ~SH     EQU $11      ;(121) as in sh_op
0012      ~Z      EQU $12      ;( 71) as in z_oo
0013      ~AW1    EQU $13      ;(146) as in l_aw_ful
0014      ~NG     EQU $14      ;(121) as in thi_ng

```

```

0015      ~WHI EQU $15      ;(146) as in f_a_ther
0016      ~QOI EQU $16      ;(103) as in l_oo_king
0017      ~QOO EQU $17      ;(185) as in b_oo_k
0018      ~L EQU $18      ;(103) as in l_and
0019      ~K EQU $19      ;( 80) as in tric_k
001A      ~J EQU $1A      ;( 47) as in ju_dg_e (~D first)
001B      ~H EQU $1B      ;( 71) as in h_ello
001C      ~G EQU $1C      ;( 71) as in g_et
001D      ~F EQU $1D      ;(103) as in f_ast
001E      ~D EQU $1E      ;( 55) as in pai_d
001F      ~S EQU $1F      ;( 90) as in pa_ss
0020      ~A EQU $20      ;(185) as in d_ay
0021      ~AY EQU $21      ;( 65) as in d_ay
0022      ~YI EQU $22      ;( 80) as in y_ard
0023      ~UH3 EQU $23      ;( 47) as in miss_io_n
0024      ~AH EQU $24      ;(250) as in m_o_p
0025      ~P EQU $25      ;(103) as in p_ast
0026      ~O EQU $26      ;(185) as in c_o_ld
0027      ~I EQU $27      ;(185) as in p_i_n
0028      ~U EQU $28      ;(185) as in m_o_ve
0029      ~Y EQU $29      ;(103) as in an_y
002A      ~T EQU $2A      ;( 71) as in t_ap
002B      ~R EQU $2B      ;( 90) as in r_ed
002C      ~E EQU $2C      ;(185) as in m_ee_t
002D      ~W EQU $2D      ;( 80) as in w_in
002E      ~AE EQU $2E      ;(185) as in d_a_d
002F      ~AE1 EQU $2F      ;(103) as in a_fter
0030      ~AM2 EQU $30      ;( 90) as in s_a_lty
0031      ~UH2 EQU $31      ;( 71) as in a_bout
0032      ~UH1 EQU $32      ;(103) as in u_ncle
0033      ~UH EQU $33      ;(185) as in c_u_p
0034      ~O2 EQU $34      ;( 80) as in f_o_r
0035      ~O1 EQU $35      ;(121) as in ab_oa_rd
0036      ~IU EQU $36      ;( 59) as in y_ou
0037      ~UI EQU $37      ;( 90) as in y_ou
0038      ~THV EQU $38      ;( 80) as in th_e
0039      ~TH EQU $39      ;( 71) as in th_in
003A      ~ER EQU $3A      ;(146) as in b_ir_d
003B      ~EH EQU $3B      ;(185) as in g_e_t
003C      ~E1 EQU $3C      ;(121) as in b_e
003D      ~AM EQU $3D      ;(250) as in c_a_ll
003E      ~lp EQU $3E      ;(185) long pause
003F      ~stop EQU $3F      ;( 47) no sound
;
2143      ORG      02143H
;
;

```

;HERO COMMAND INTERFACE ROUTINES - C Language Interface

;Version 6
;Written by A. H. Ballard, 11/21/83
;Updated 7-6-84

; These routines allow external programs to interface
;with the motors, sensors, speech, and other subsystems
;in the Hero 1.x robot. The interface is implemented
;as a series of subroutine calls. The parameters, or
;operands, for each subroutine are first pushed onto the
;stack. All operands have 16 bits, with right justifi-
;cation. The last operand is stacked first, and the
;first operand is stacked last. A subroutine call is
;then made to one of the 85 jump vectors provided at the
;beginning of this program.

; In this version, 35 of the 38 interpreted HERO
;commands are included in the jump table, although the
;SLEEP is not actually implemented in this version. The
;CRL (change to robot language) and CML (change to
;machine language) are not included because they are
;not appropriate for external use. The JISP (jump if
;speaking) command is actually a subroutine call to a
;lower level in the phoneme tree, and is not included
;either. Room for expansion to a total of 85 commands
;is provided in the jump table.

; Maximum use is made of subroutines which already
;exist in the Hero ROM. Where no operands need to be
;passed, it is usually possible to jump directly to an
;existing ROM subroutine. Where one or more operands
;have to be passed, they are reformatted in this pro-
;gram to satisfy the entry conditions required by
;existing ROM subroutines.

;Entry points in existing ROM:

E390	ABM	EQU	4E390	;First of 16 direct entry points
E399	ASH	EQU	4E399	; (see jump table for comments)
E39D	AAH	EQU	4E39D	
E3B2	ASP	EQU	4E3B2	
E417	ZERO	EQU	4E417	
F423	RTE	EQU	4F423	
E0A9	ENEYE	EQU	4E0A9	
E0AD	ENEAR	EQU	4E0AD	
E0B8	ENSON	EQU	4E0B8	
E0BC	ENMDT	EQU	4E0BC	
E0C0	ENDIS	EQU	4E0C0	
E0CA	DISEYE	EQU	4E0CA	
E0D5	DISEAR	EQU	4E0D5	
E0E0	DISSON	EQU	4E0E0	

```

; USER DECLARED TABLES
0023 NVEC EQU 35 ;Current number of jump vectors
;
;
;
2143 SPKTAB RMB 1 ;Table of phrase addresses
;
2144 POSITAB RMB 1 ;Table of motor positions
;
;
;RAM locations for parameters:
;
0020 CPOSTAB EQU 10020 ;CURRENT MOTOR POSITION TABLE
002B ACTSTAT EQU 1002B ;Activity status byte
0F20 ACTMASK EQU 10F20 ;Mask to select ACTSTAT bits
;
;
C220 EXP_OUT EQU 1C220 ;EXP_OUT_ADDR EXPERIMENTAL BOARD OUTPUT BYTE
C2A0 EXP_IN_A EQU 1C2A0 ;EXP_IN_ADDR EXPERIMENTAL BOARD INPUT BYTE
;
0023 NVEC EQU 35 ;Current number of jump vectors
;
;
;
2145 39 RTRN RTS ;Default for unimplemented
; routines
;
;
;
;activity()
activity
;{
; char *stat;
; /* check if motors are currently running, return true if they are,
; false otherwise. */
;
; stat = ACTSTAT;
; return (*stat & 0x0F);
2146 C6 0F LDAB #10F ;LOAD MASK FOR ACTSTAT
2148 20 0E BRA BUSY
;}
;
214A C4 01 BBSY LDAB #01 ;Activity bit for base
214C 20 0A BRA BUSY
214E C6 02 SBSY LDAB #02 ;Activity bit for steering
2150 20 06 BRA BUSY
2152 C6 04 ABSY LDAB #04 ;Activity bit for arm/head
2154 20 02 BRA BUSY

```

```

2156 C6 08 VBSY LDAB #08 ;Activity bit for voice (speech)
;
2158 D4 2B BUSY ANDD ACTSTAT ;Test busy status
215A 4F CLRA
215B 39 RTS ;Return with D = 0 if not busy
;
;
;
;
215C 86 08 SPWX LDAA #08 ;Setup wait for speech
215E 20 01 BRA SPCX.1
;
;
2160 4F SPCX CLRA ;Setup to continue
2161 B7 0F 20 SPCX.1 STAA ACTMASK
2164 30 TSX
2165 E6 03 LDAB 3,X ;B = phrase number
2167 58 ASLB ;B = address offset
2168 FE 21 43 LDX SPKTAB ;Point to phrase table
216B 3A ABX ;Point to phrase address
216C E6 00 LDAB 0,X
216E A6 01 LDAA 1,X ;BA = phrase address
2170 7E E3 5F JMP SPKEXTRN
;
;
2173 86 08 SPWE LDAA #08 ;Setup wait for speech
2175 20 01 BRA SPCE.1
;
;
2177 4F SPCE CLRA ;Setup to continue
2178 B7 0F 20 SPCE.1 STAA ACTMASK
217B 30 TSX
217C E6 02 LDAB 2,X
217E A6 03 LDAA 3,X ;BA = phrase address
2180 7E E3 5F JMP SPKEXTRN
;
;
2183 30 PAUSE TSX
2184 EE 02 LDX 2,X ;IX = count (1/16 sec steps)
2186 7E E4 99 JMP PSE.EXT
;
;
2189 7E 21 45 SLEEP JMP RTRN ;Not currently implemented
;
;
218C 86 07 MVMR LDAA #07 ;Setup motor wait bits
218E 20 01 BRA MVCR.1
;
;
2190 4F MVCR CLRA ;Setup to continue
2191 B7 0F 20 MVCR.1 STAA ACTMASK
2194 30 TSX
2195 EE 02 LDX 2,X ;IX = 2-byte operand
2197 7E E1 69 JMP MVR.EXT ;Use existing ROM routine
;
;
219A 86 07 MVMI LDAA #07 ;Setup motor wait bits
219C 20 01 BRA MVCI.1
;

```

210

219E	4F	MVCI	CLRA	;Setup to continue
219F	B7 0F 20	MVCI.1	STAA ACTMASK	
21A2	30		TSX	
21A3	EE 02		LDX 2,X	;IX = 2-byte operand
21A5	7E E1 14		JMP MVI.EXT	;Use existing ROM routine
21A8	86 07	MVIX	LDA 007	;Setup motor wait bits
21AA	20 01		BRA MVX.1	
21AC	4F	MVCX	CLRA	;Setup to continue
21AD	B7 0F 20	MVCX.1	STAA ACTMASK	
21B0	30		TSX	
21B1	E6 03		LDAB 3,X	;B = position index
21B3	58		ASLB	;B = address offset
21B4	FE 21 44		LDX POSITAB	;Point to table of positions
21B7	3A		ABX	;Point to selected position
21B8	7E E1 51		JMP MVX.EXT	;Use existing ROM routine
21BB	86 07	MVME	LDA 007	;Setup motor wait bits
21BD	20 01		BRA MVCE.1	
21BF	4F	MVCE	CLRA	;Setup to continue
21C0	B7 0F 20	MVCE.1	STAA ACTMASK	
21C3	30		TSX	
21C4	EE 02		LDX 2,X	;IX = address of operand
21C6	7E E1 2A		JMP MVE.EXT	;Use existing ROM routine
21C9	30	MVALL	TSX	
21CA	08		INX	
21CB	08		INX	;IX will point to 1st operand
21CC	A6 01		LDA 1,X	
21CE	A7 00		STAA 0,X	;1st operand = EXTPOS
21D0	A6 03		LDA 3,X	
21D2	A7 01		STAA 1,X	;2nd operand = SHLPOS
21D4	A6 05		LDA 5,X	
21D6	A7 02		STAA 2,X	;3rd operand = ROTPOS
21D8	A6 07		LDA 7,X	
21DA	A7 03		STAA 3,X	;4th operand = PVTPOS
21DC	A6 09		LDA 9,X	
21DE	A7 04		STAA 4,X	;5th operand = GRPPOS
21E0	A6 0B		LDA 11,X	
21E2	A7 05		STAA 5,X	;6th operand = HEDPOS
21E4	A6 0D		LDA 13,X	
21E6	A7 06		STAA 6,X	;7th operand = STRPOS
21E8	7E E1 FC		JMP MVALLX	
21EB	30	MV	TSX	
21EC	C6 40		LDAB #01000000B	;SET FOR SLOW SPEED
21EE	A6 03		LDA 3,X	;A NOW IS MOTOR INDEX
21F0	04		LSRD	;ALIGN BITS IN B REG
21F1	04		LSRD	
21F2	04		LSRD	

```

21F3 A6 05          LDA  5,X          ;A IS POSITION
21F5 36            PSHA          ; NOTE FOLLOWING REVERSAL FROM STANDARD PUSH
21F6 37            PSHB          ; <<<<<<----- ORDER
21F7 38            PULX          ; IX = 2-BYTE OPERAND
21F8 7E E1 14      JNP   MVI.EXIT ; GO TO HERO ROM AND RETURN
;
;
0F24              SRC.H EQU  $0F24
0F22              DEST.H EQU $0F22
E291              MOVE.H EQU $E291
;
21FB CE 22 0C      MAXPOS LDX  @MAXTBL ;POINT TO TABLE OF MAX POSITIONS
21FE FF CF 24      STY   SRC.H   ;$0F24 IN HERO RAM
2201 CE 00 20      LDX  @CPOSTAB ;$0020 IN HERO RAM
2204 FF 0F 22      STX   DEST.H  ; $0F22 IN HERO RAM
2207 C6 07         LDAB @7       ; COUNT IS 7 BYTES
2209 7E E2 91      JNP   MOVE.H  ;$E291 IN HERO ROM
220C 98 86 93 A5   MAXTBL FCB  $98,$86,$93,$A5,$75,$C9,$93
2210 75 C9 93
;
;
;EXPOUT(c)
; char c;
EXPOUT
;( EXPOUTPUT = c; /* output the data to the experimenter port */
TSX
ldab 3,X
stab $C220
;)
2213 30            RTS
;EXPINP()
EXPINP
;( return EXPINPUT ; /* input the data from the experimenter port */
cra
ldab $C2A0
RTS
221A 4F
221B F6 C2 A0
221E 39
;
;
; The following equates state how the functions in Menos utilize the
;routines above. Please do not assume that Menos uses all of the
;above routines. Menos must never wait too long for a routine (such
;as zero) to execute, and thus has equivalent routines, with the names
;given as below, which perform the function of the above routines.
;
;
E390 abmvec EQU  ABM   ;Abort base motor
E399 asmvec EQU  ASH   ;Abort steering motor
E39D aanvec EQU  AAM   ;Abort arm/head motors
E3B2 aspvec EQU  ASP   ;Abort speech
214A bbsyvec EQU  BBSY  ;Test for base busy
214E sbsyvec EQU  SBSY  ;Test for steering busy

```

2152	absyvec	EQU	ABSY	;Test for arm/head busy
2156	vbsyvec	EQU	VBSY	;Test for voice (speech) busy
E417	zrovec	EQU	ZERO	;Initialize all stepper motors
F423	rtevec	EQU	RTE	;Return to executive mode
E0A9	eldvec	EQU	ENEYE	;Enable light detector (eye)
E0AD	esdvec	EQU	ENEAR	;Enable sound detector (ear)
E0B8	eurvec	EQU	ENSON	;Enable ultrasonic ranger
E0BC	endvec	EQU	ENMDT	;Enable motion detector
E0C0	edsvec	EQU	ENDIS	;Enable display
E0CA	dldvec	EQU	DISEYE	;Disable light detector (eye)
E0D5	dsdvec	EQU	DISEAR	;Disable sound detector (ear)
E0E0	durvec	EQU	DISSON	;Disable ultrasonic ranger
E0E4	dadvec	EQU	DISMDT	;Disable motion detector
E0E8	ddsvec	EQU	DISDIS	;Disable display
215C	spwxvec	EQU	SPWX	;Speak and wait (indexed)
2160	spcxvec	EQU	SPCX	;Speak and continue (indexed)
2173	spwvec	EQU	SPWE	;Speak and wait (extended)
2177	spcevec	EQU	SPCE	;Speak and continue (extended)
2183	psevec	EQU	PAUSE	;Pause for specified time
2189	slpvec	EQU	SLEEP	;Sleep for specified time
219A	mwivec	EQU	MWVI	;Move and wait (immediate)
219E	mcivec	EQU	MVCI	;Move and continue (immediate)
218C	mwrvec	EQU	MVMR	;Move relative, wait (immediate)
2190	mcrvec	EQU	MVCR	;Move relative, continue (immed)
21A8	mwxvec	EQU	MVWX	;Move and wait (indexed)
21AC	mcxvec	EQU	MVCX	;Move and continue (indexed)
21B8	mwevec	EQU	MVWE	;Move and wait (extended)
21BF	mcevec	EQU	MVCE	;Move and continue (extended)
21C9	mvlvec	EQU	MVALL	;Move all 7 stepper motors
21FB	satrmax	EQU	MAXPOS	;Set all motor position registers to max
21EB	mtrmvec	EQU	MNV	;Special MVCI at medium speed
221A	expinpve	EQU	EXPINP	;Get experimental board input
2213	expoutve	EQU	EXPOUT	;Output byte to experimental port
F37E	PWRON	EQU	9F37E	;WARM START ADDRESS—NO RETURN EXPECTED
7EFD	RTHH	EQU	97EFD	;RETURN TO MOD-HERO IN VERSION 1.1B OF VAMP
221F			END	

No error(s).

SYMBOL TABLE FOR FILE: DRIVEDEF.A

AAM	E39D	ABM	E39D	ABSY	2152	ABTSTAT	002C
ACNT	0015	ACTIVATE	0F21	ACTMASK	0F20	ACTSTAT	002B
ADDR	0F2E	ADDRPTR	0F2C	ADRPCPY	0F02	ADRPORT	C2C0
ARMBACK	0F41	ARMON	0F40	ARMSTOP	0F42	ARMSTP	0EF0
ASN	E399	ASP	E3B2	BASEDP	0F46	BBSY	214A
BKPNSTK	0FEC	BKTBL	0FE0	BUSY	2158	CLKPORT	C300
CLCKTIME	0FEC	CLRDIS	F65B	CNTR	0009	COL1	C003
COL2	C005	COL3	C006	CPOSTAB	0020	CR3	000F
DOR1	0000	DORICPY	0006	DOR2	0001	DOR3	0004
DOR4	0005	DELAYTM	0F43	DEST	0F22	DEST.H	0F22
DG1ADD	C11F	DG2ADD	C12F	DG3ADD	C13F	DG4ADD	C14F
DG5ADD	C15F	DG6ADD	C16F	DIGADD	0FF2	DIR	0F3C
DISDIS	E0E8	DISEAR	E0D5	DISEYE	E0CA	DISLMD	0F4E
DISMDT	E0E4	DISSON	E0E0	DR1	0002	DRICPY	000F
DR2	0003	DRZCPY	0004	DR3	0006	DR4	0007
DRVNO	0EFD	DRVON	0029	DRVON	0F3E	DRVPCPY	0F00
DRVPMEN	0F01	DRVPORT	C2A0	DRVPOS	0027	DSHDIR	0FFB
DSHPTR	0FF9	ENDIS	E0C0	ENEAR	E0AD	ENEYE	E0A9
ENDMT	E0BC	ENSON	E0B8	EXPINP	221A	EXPIPORT	C2A0
EXPOGRT	C220	EXPOUT	2213	EXP_IN_A	C2A0	EXP_OUT_	C220
EXTPORT	C280	EXTPOS	0020	FRSTADDR	0F32	GRPPOS	0024
HEDPOS	0025	HUNGRY	002F	ICR1	000D	ICR2	001E
IRGCPY	0F04	IRGPORT	C200	IRQ_PORT	C200	ISARM	0F3D
ISOLD	0F3A	LASTADDR	0F34	LIMIT	C260	LIMPORT	C260
LRMODE	0F36	MAXPOS	21FB	MAXTBL	220C	NCB	0F1E
MNV	21EB	MODE	0EE1	MONSTK	0F98	MOVE.H	E291
MTR	0F4A	MTRSPD	0F1B	MVALL	21C9	MVALLOP	0F26
MVALLX	E1FC	MVCE	21BF	MVCE.1	21C0	MVCI	219E
MVC1.1	219F	MVCR	2190	MVCR.1	2191	MVCX	21AC
MVCX.1	21AD	MVE.EXT	E12A	MVI.EXT	E114	MVR.EXT	E169
MME	21BB	MWI	219A	MWR	218C	MWX	21A8
MVX.EXT	E151	MVEC	0023	OCR1	000B	OCR2	001A
OCR3	001C	OLDADDR	0F30	OLDDIR	0F38	OLDDIS	0F4C
OLDLMD	0F4F	OLDPOS	0F39	OLDS'.CT	0F37	OPCODE	0F47
OUTSTR	F7E5	PAUSE	2183	PCSAVE	0EE2	POS	0F48
POSITAB	2144	PSE.EXT	E499	PVTPOS	0023	PMRON	F37E
PWRPCPY	0F03	PWRPORT	C2E0	PWRSTK	0F18	PWRTEMP	0EDF
RANC	0014	RDR	0012	REMPORT	C280	REVADDR	0F2A
REVPOS	0F28	RMCR	0010	ROTPOS	0022	RTE	F423
RTMH	7EFD	RTRN	2145	RXBUF	0EDE	RXSTAT	0EDD
SBSY	214E	SENSE	C240	SENSPORT	C240	SHLPOS	0021
SLCT	0F3B	SLEEP	2189	SLEEPER	002D	SNRHIT	0030
SNRPORT	C220	SNRRNG	0031	SNRTMR	C220	SPCE	2177
SPCE.1	2178	SPCHPORT	C240	SPCX	2160	SPCX.1	2161
SPD	0F4B	SPKEXTRN	E35F	SPKTAB	2143	SPSAVE	0F56
SPSKAREA	0F05	SPSKFWA	0F15	SPSKLWA	0F17	SPSKPTR	0F19
SPWE	2173	SPWX	215C	SRC	0F24	SRC.H	0F24
STPPTR	0F52	STRCTADR	0F1C	STRGON	0F3F	STRPCPY	0EF1
STRPORT	C260	STRPOS	0026	STRSTP	0EE4	SYSSWI	0FF6

T0	0059	T1	005B	T2	005D	TCR1	0017
TCR2	0018	TCSR	0008	TDR	0013	TE0	0FE0
TE1	0FF0	TEACHING	C280	TEMP1	0F54	TIME1	0FFC
TIME2	0FFE	TRCS	0011	TRIGIN	0F45	TSR	0019
UEXCLOCK	F01E	UEXCYLE	E001	UEXEXP	F012	UEXINTRP	E024
UEXIRQ	EF0C	UEXLD8	F2D9	UEXLLB	F256	UEXMOT	F004
UEXSPD	F02E	UEXTRG	F00B	UEXUSER1	F53B	UEXUSER2	F541
UEXUSER3	F547	USER1	0050	USER2	0053	USER3	0056
USERS	0FF4	USRCLOCK	003B	USRCYCLE	0032	USREXP	004D
USRINTRP	0035	USRIRQ	0038	USRLDB	0044	USRLLB	0041
USRMDT	0047	USRRAH	005F	USRSPD	003E	USRSTK	0F58
USRTRG	004A	VBSY	2156	XTEMP	0F50	ZERO	E417
'!	00A0	'.	0060	'0	007E	'1	0030
'2	006D	'3	0079	'4	0033	'5	005B
'6	005F	'7	0070	'8	007F	'9	007B
'?	0065	'A	0077	'B	001F	'C	004E
'D	003D	'E	004F	'F	0047	'G	005E
'H	0037	'I	0030	'J	003C	'L	000E
'O	007E	'S	005B	'U	003E	'_	0008
'a	007D	'b	001F	'c	000D	'd	003D
'h	0017	'hy	0001	'n	0015	'o	001D
'p	0067	'qt	0022	'r	0005	'sp	0000
't	0070	'u	001C	'y	003B	aanvec	E39D
abnvec	E390	absyvec	2152	activity	2146	asnvec	E399
asbvec	E3B2	bbsyvec	214A	ddsvec	E0E8	dldvec	E0CA
dsdvec	E0E4	dsdvec	E0D5	durvec	E0E0	edsvec	E0C0
eldvec	E0A9	emdvec	E0BC	esdvec	E0AD	eurvec	E0B8
expinpve	Z21A	expoutve	Z213	mcevec	21BF	ncivec	219E
mcrvec	2190	mcxvec	21AC	npos	0020	ntravec	21EB
mlvec	21C9	mvevec	21BB	mwivec	219A	nrvec	218C
muxvec	21A8	psevec	2183	rtevec	F423	sbsyvec	214E
slpvec	2189	sntrmax	21FB	spcvec	2177	spcxvec	2160
spwvec	2173	spuxvec	215C	vbsyvec	2156	zrevec	E417
~A	0020	~A1	0006	~A2	0005	~AE	002E
~AE1	002F	~AH	0024	~AH1	0015	~AH2	0008
~AW	003D	~AW1	0013	~AW2	0030	~AY	0021
~B	000E	~CH	0010	~D	001E	~DT	0004
~E	002C	~E1	003C	~EH	003B	~EH1	0002
~EH2	0001	~EH3	0000	~ER	003A	~F	001D
~G	001C	~H	001B	~I	0027	~I1	0008
~I2	000A	~I3	0009	~IU	0036	~J	001A
~K	0019	~L	0018	~H	000C	~H	000D
~NG	0014	~O	0025	~O1	0035	~O2	0034
~OO	0017	~OO1	0016	~P	0025	~R	002B
~S	001F	~SH	0011	~T	002A	~TH	0039
~THV	0038	~U	0028	~U1	0037	~UH	0033
~UH1	0032	~UH2	0031	~UH3	0023	~V	000F
~W	002D	~Y	0029	~Y1	0022	~Z	0012
~ZH	0007	~lp	003E	~sp	0003	~stop	003F

APPENDIX F

Navigation Computer Parts List

U0 LOC.	TYPE	#PINS	PARTS USED	+5VDC	GROUPO	+6VDC	+12VDC	-12VDC
1	DC-DC	24	ALL	1	10,12,13,15		11,14	
0	AA37 DC-DC	24	ALL	1	11,12,13,14			10,15
1	AA15 6802	40	ALL	2,3,8,35	1,21			
2	AD1 74LS244	20	ALL	20	10			
3	AD14 74LS244	20	ALL	20	10			
4	AD26 74LS245	20	ALL	20	10			
5	AD38 74LS245	20	ALL	20	10			
6	AF1 74LS04	14	1,2,3,4	14	7			
7	AF10 74LS14	14	1,2,3,4,11,15, 13,14	14	7			
8	AF18 74LS138	16	ALL	16	8			
9	AF28 74LS138	16	ALL	16	8			
10	AF38 74LS00	14	1,2,3,4,5,6	14	7			
11	AH1 EDH8800	28	ALL	28	14			
12	AH18 EDH8800	28	ALL	28	14			
13	AH34 EDH8800	28	ALL	28	14			
14	BB1 EDH8800	28	ALL	28	14			
15	BB18 EDH8800	28	ALL	28	14			
16	BB34 EDH8800	28	ALL	28	14			
17	BE1 6850	24	ALL	12	1			
18	BE18 2764	28	ALL	1,26,28	14			
19	BE34 14411	24	ALL	26	12			
20	BH1 6850	24	ALL	12	1			
21	BH20 6821	40	ALL	20	1			
22	BH42 1488	14			7		14	1
23	CB1 74125	14	1,2,3,4,5,6	14	1,7			
24	CB20 6821	40	ALL	20	1			
25	CB42 1609	14		14	7			
26	CE1 6840	28	T1, T2	14	1			
27	CE18 6840	28	T1, T2	14	1			
28	CE34 6840	28	T3	14	1			
29	CJ1 75468	16	ALL	9	8			
30	CJ10 75468	16	ALL	9	8			
31	CJ20 75468	16	ALL	9	8			
32	CJ30 75468	16	ALL	9	8			
33	CJ42 75468	16	ALL	9	8			
34	DC1 RELAY	14	A0			2		
35	DC9 RELAY	14	B0			2		
36	DC17 RELAY	14	C0			2		
37	DC25 RELAY	14	D0			2		

UO LOC.	TYPE	#PINS	PARTS USED	+5VDC	GROUND	+6VDC	+12VDC	-12VDC
38	DC33 S2	16	ALL					
39	DC42 S1	16	ALL					
40	DE1 RELAY	14	A1			2		
41	DE9 RELAY	14	B1			2		
42	DE17 RELAY	14	C1			2		
43	DE25 RELAY	14	D1			2		
44	DE33 74LS74	14		14	7			
45	DE42 74LS74	14		14	7			
46	DO1 RELAY	14	A2			2		
47	DO9 RELAY	14	B2			2		
48	DO17 RELAY	14	C2			2		
49	DO25 RELAY	14	D2			2		
50	DC33 75468	16	SPARE	9	8			
51	DC42 7404	14	1,2,3,4,5,6,8,9 14		7			
52	DJ1 RELAY	14	A4			2		
53	DJ9 RELAY	14	B4			2		
54	DJ17 RELAY	14	C4			2		
55	DJ25 RELAY	14	D4			2		
56	DJ33 7404	14	1,2,3,4,5,6,8,9 14		7			
57	EC1 RELAY	14	A5			2		
58	EC9 RELAY	14	B5			2		
59	EC17 RELAY	14	C5			2		
60	EC25 RELAY	14	D5			2		
61	EE1 RELAY	14	A6			2		
62	EE9 RELAY	14	B6			2		
63	EE17 RELAY	14	C6			2		
64	EE25 RELAY	14	D6			2		
65	EO1 RELAY	14	SPARE			2		
66	EO9 RELAY	14	SPARE			2		
67	EO17 RELAY	14	SPARE			2		
68	EO25 RELAY	14	SPARE			2		
69	EJ1 RELAY	14	SPARE			2		
70	EJ9 RELAY	14	SPARE			2		
71	EJ17 RELAY	14	SPARE			2		
72	EJ25 RELAY	14	SPARE			2		
73	EB34 2764	28	ALL	1,26,28	14			
74	CB10 74LS138	16		16	8			
75	EE34 6850	24		12	1			
76	FB33 74LS138	16	ALL	16	8			
77	FB43 74LS138	16	ALL	16	8			
78	OSE 6840	28	ALL	19	20			
79	OSE 6840	28	ALL	19	20			
80	OSE 6840	28	ALL	19	20			
81	OSE CONNECTOR							
82	OSE CONNECTOR							
83	EJ43 74LS123	16		16	8			
84	OSE DM9602	16	ALL	16	8			
85	OSE DM9602	16	ALL	16	8			
86	OSE DM9602	16	ALL	16	8			

UN LOC.	TYPE	#PINS	PARTS USED	+5VDC	GROUND	+6VDC	+12VDC	-12VDC
CD1	420 KHz		Clock Board					
EB1	TIP125 and D1-D9		(silicon signal diodes)					
			Sonar Boards (A,B,C,D)					
			S1 (Reset, momentary)					
DJ41	RESISTOR PACK	(5.1 K)						
AA13	6 MHz		CRYSTAL					
BF47	1.8432 MHz		CRYSTAL					
			RESISTOR PACK (5.1 K)					
			(BUTTON OF NAV CPU BOARD)					
			24 POLAROID SONAR TRANSDUCERS					
			(ON ROBOT BODY PANNELS)					

APPENDIX G

NAVIGATION COMPUTER SCHEMATICS

Appendix G contains the following schematics:

Fig	Page
G.1 CPU ControlBus.....	G-2
G.2 CPU Address Bus.....	G-3
G.3 CPU Data Bus.....	G-4
G.4 RAM/ROM Address and Data Bus.....	G-4
G.5 I/O Address and Data Bus.....	G-5
G.6 RAM/ROM Chip Enables.....	G-6
G.7 I/O Chip Enables.....	G-7
G.8 I/O Auxiliary Signals.....	G-8
G.9 ROM Overlay RAM circuits.....	G-9
G.10 Serial I/O Ports.....	G-10
G.11 Buffered Sonar Signals.....	G-11
G.12 Sonar Timer/Range Board Interface.....	G-12
G.13 Sonar Transducer Selection Circuitry.....	G-13
G.14 Sonar Transducer Relay Interface.....	G-14
G.15 Optical Shaft Encoder Timer/Counter Circuit.....	G-15
G.16 24 Pin Sonar Transducer Header.....	G-16
G.17 Dual Sonar Range Board 20 Pin Header.....	G-16
G.18 Optical Shaft Encoder Board 40 Pin Header.....	G-17

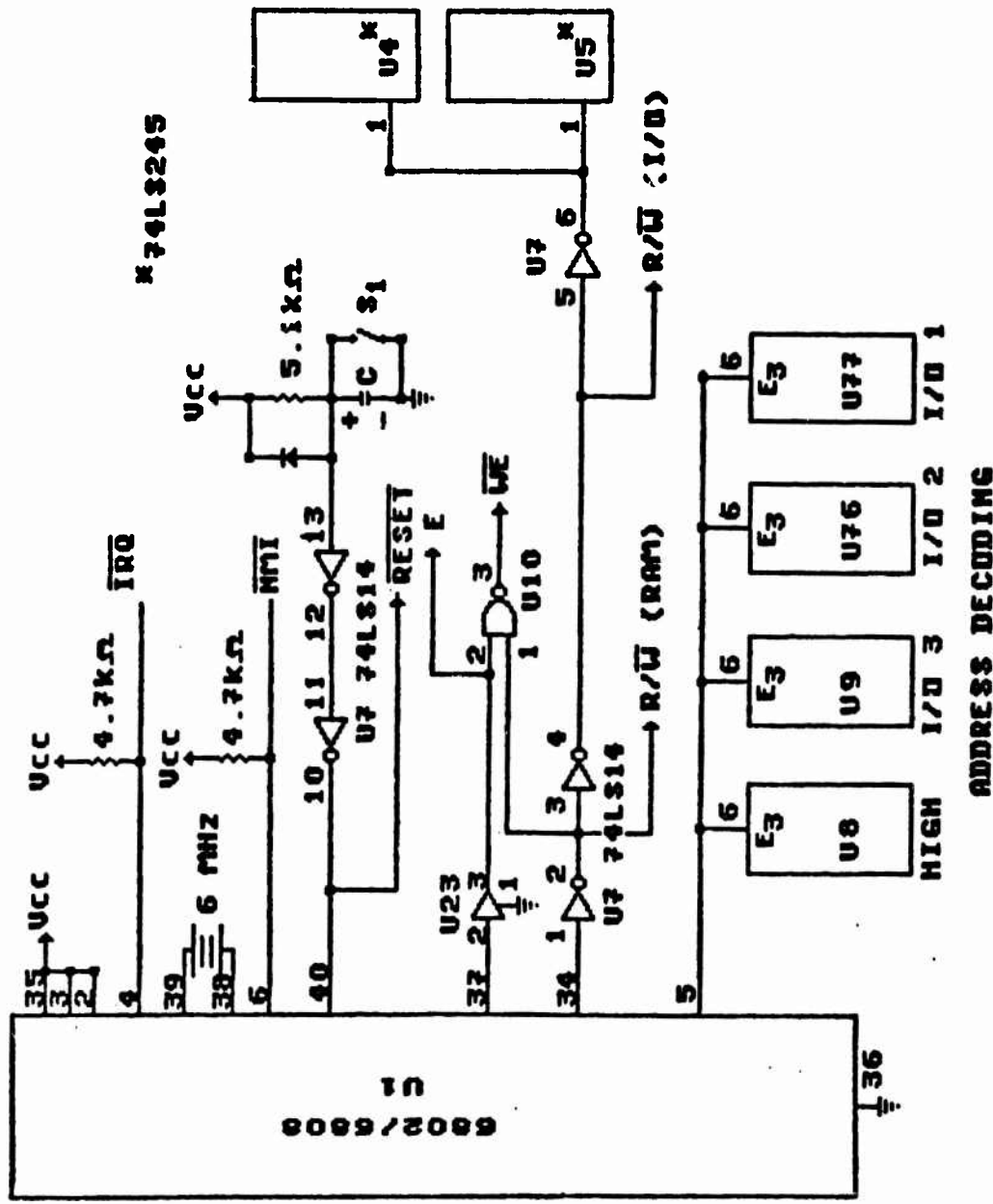
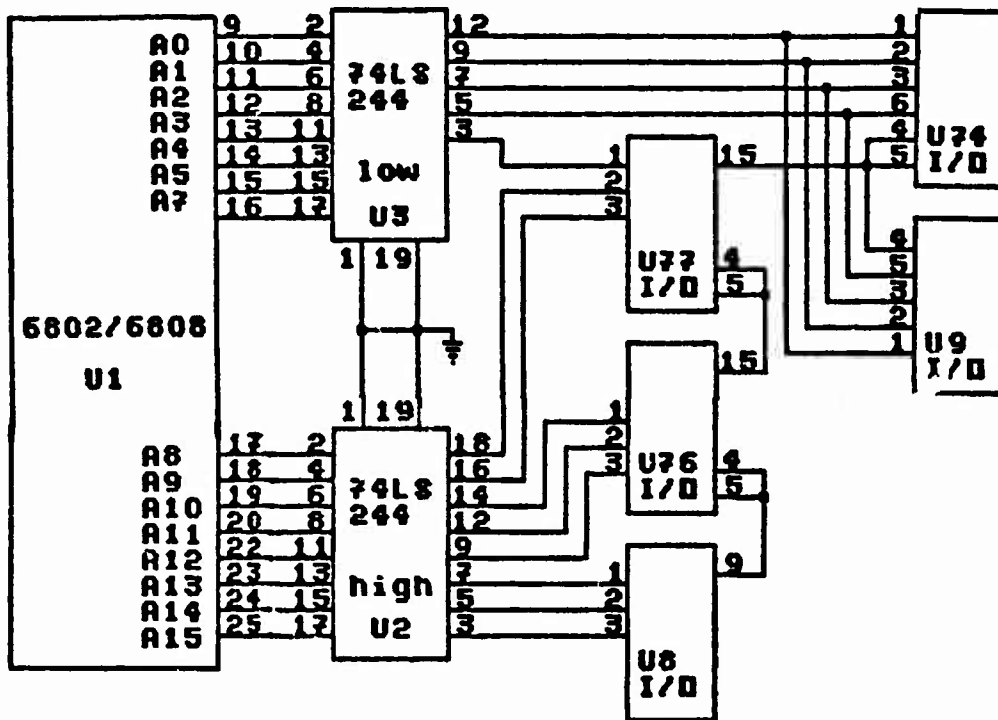

Fig. G.1 CPU Control Bus



U2	74LS244	HIGH ADDRESS
U3	74LS244	LOW ADDRESS
U8	74LS138	8K of 64K
U9	74LS138	8 of 64
U74	74LS138	8 of 64
U76	74LS138	1K of 8K
U77	74LS138	128 of 1K

Fig. G.2 CPU Address Bus

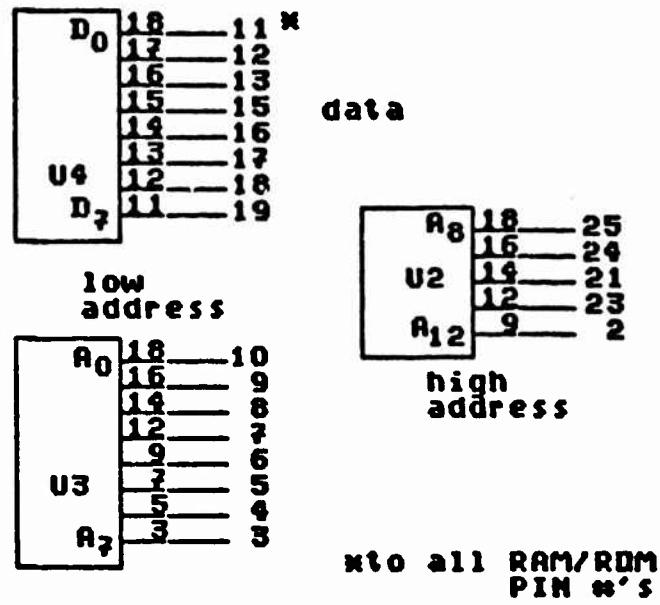

Fig. G.3 CPU Data Bus

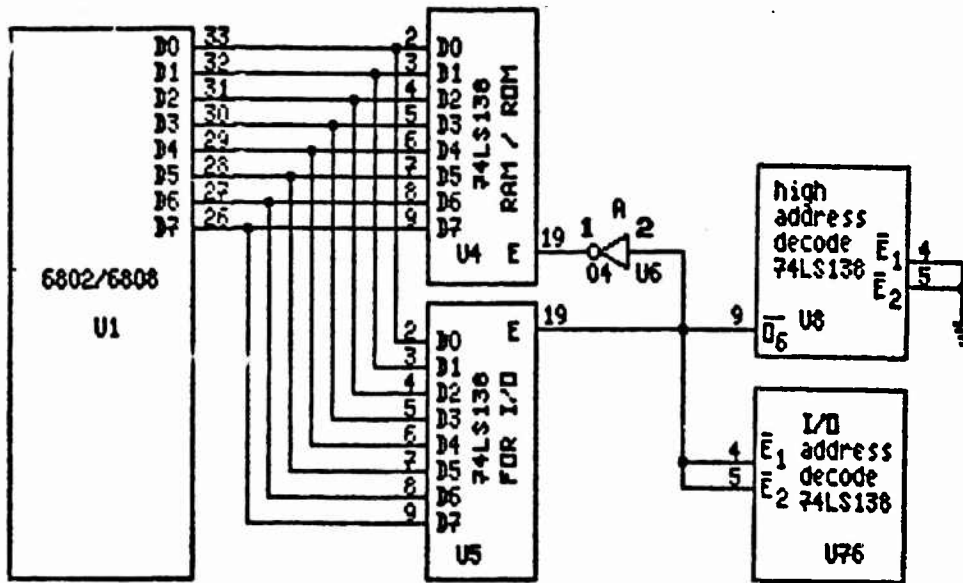

Fig. G.4 RAM/ROM Address and Data Bus

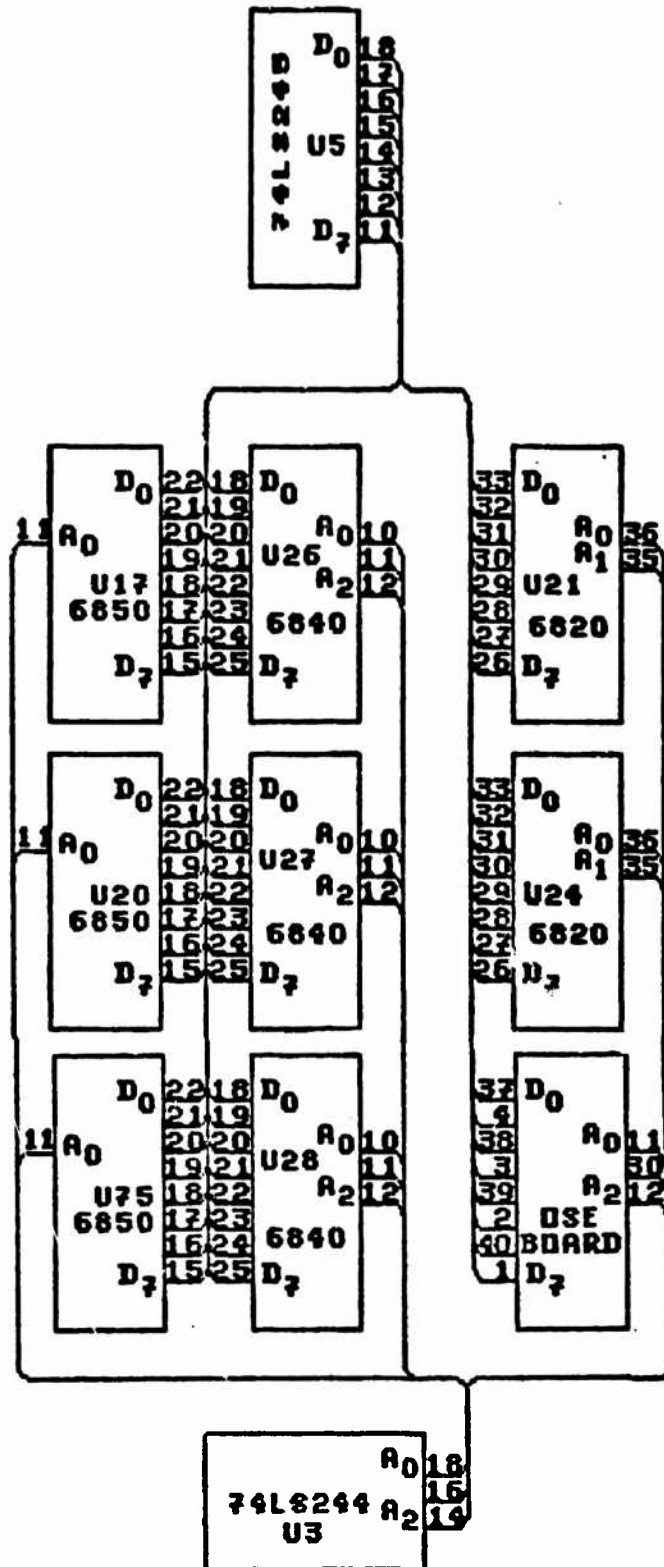

Fig. G.5 I/O Address and Data Bus

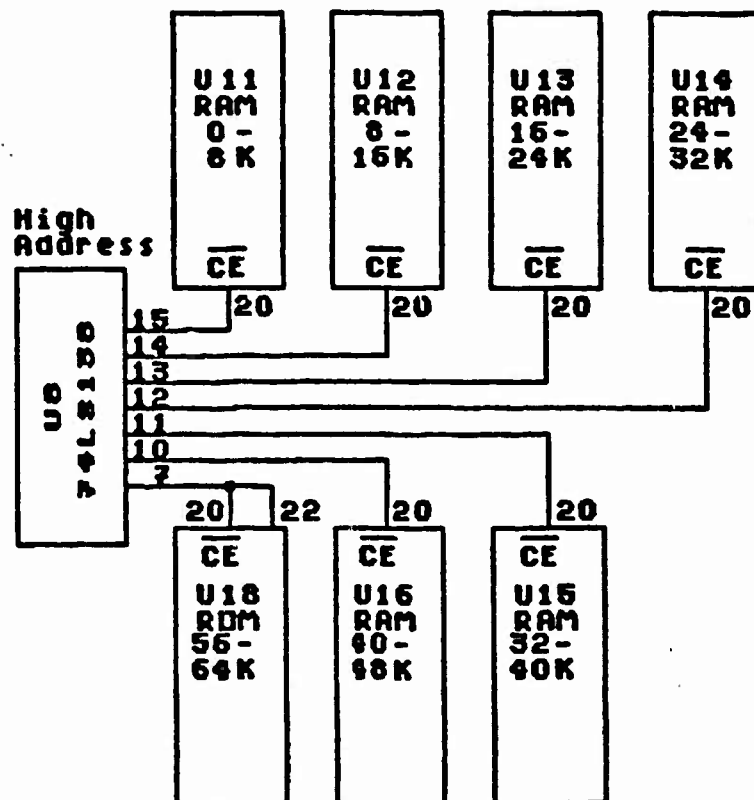

Fig. G.6 RAM/ROM Chip Enables

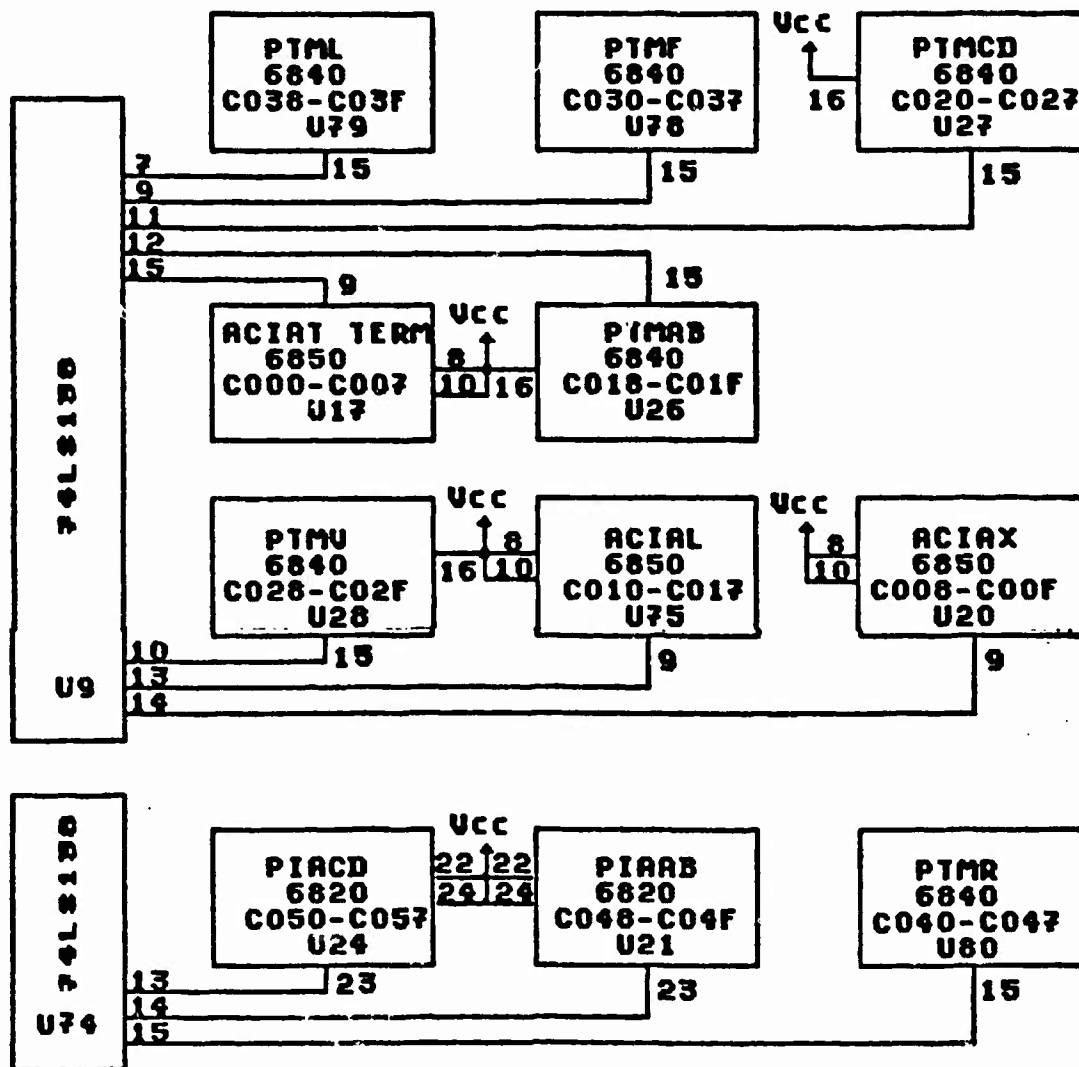

Fig.G.7 I/O Chip Enables

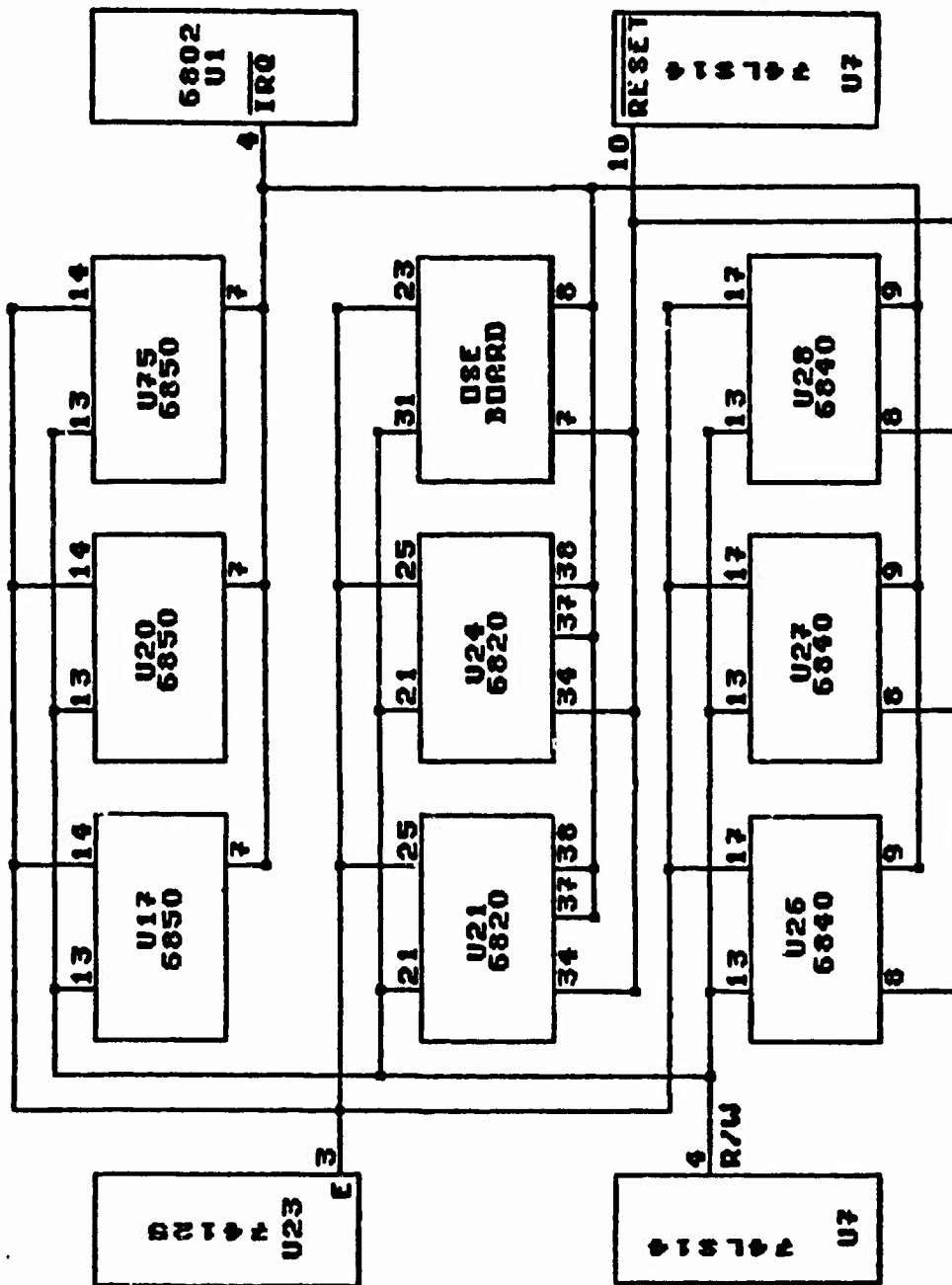

Fig. G-8 I/O Auxiliary Signals

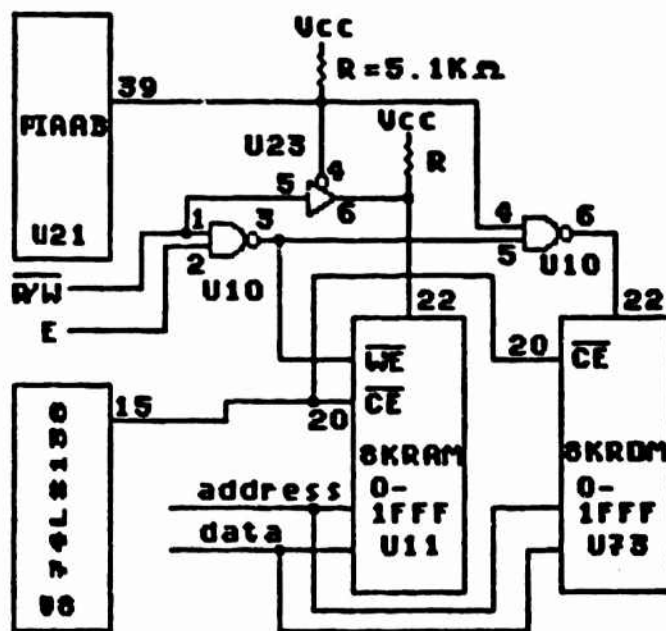

Fig. G.9 ROM Overlay RAM Circuit

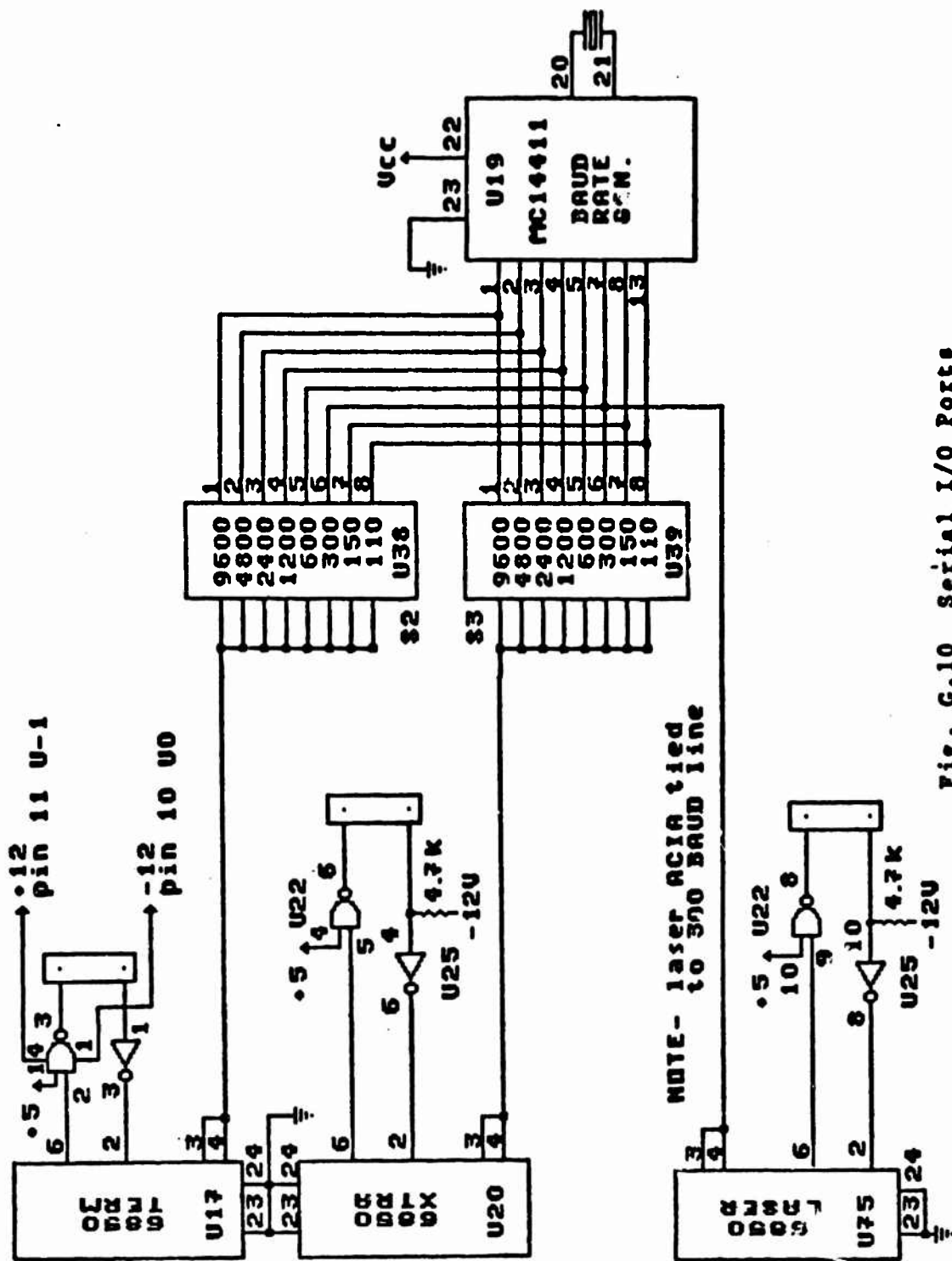

Fig. G.10 Serial I/O Ports

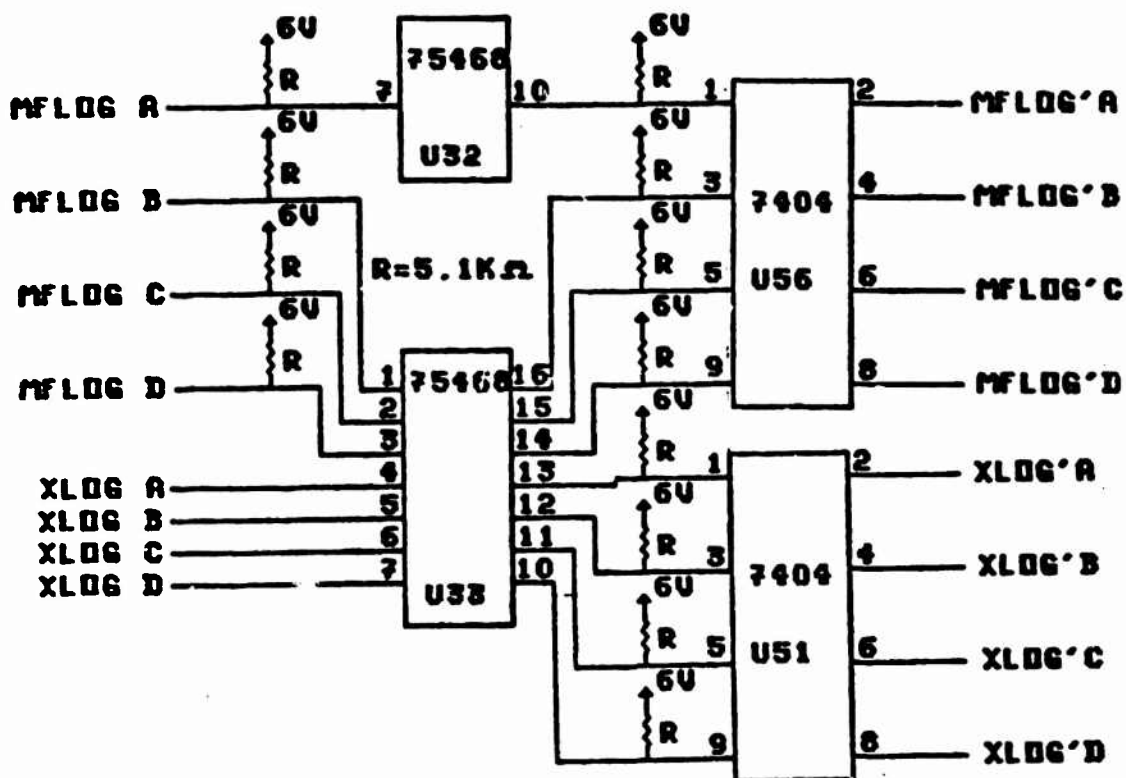

Fig. G.11 Buffered Sonar Signals

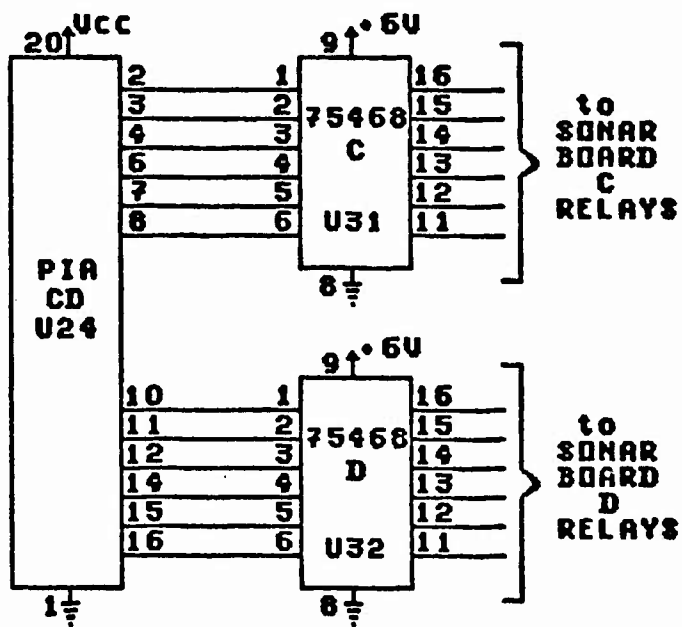
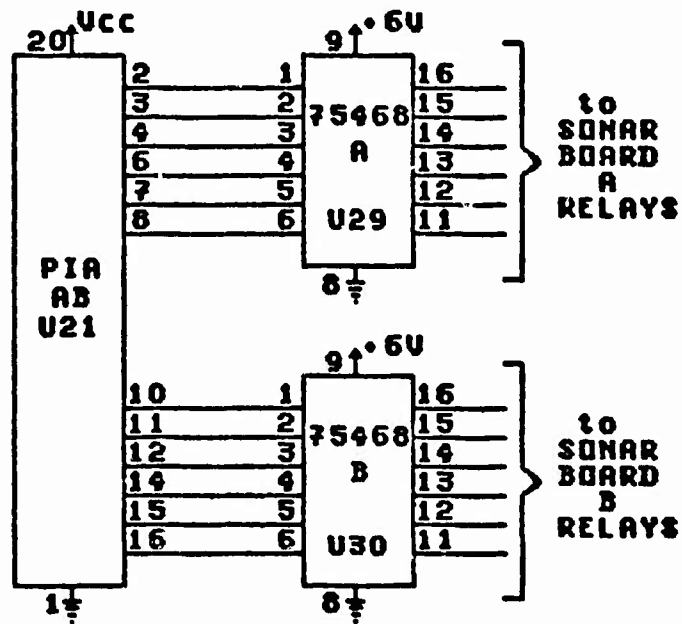
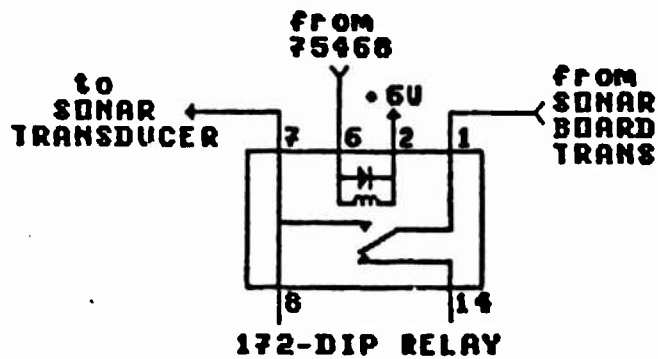

Fig. G-13 Sonar Transducer Selection Circuitry



The transmit line of each SONAR BOARD is tied to eight relays. Each relay is tied to one SONAR transducer. A shielded coaxial line is used between each relay and each transducer.

Fig. G.14 Sonar Transducer Relay Interface

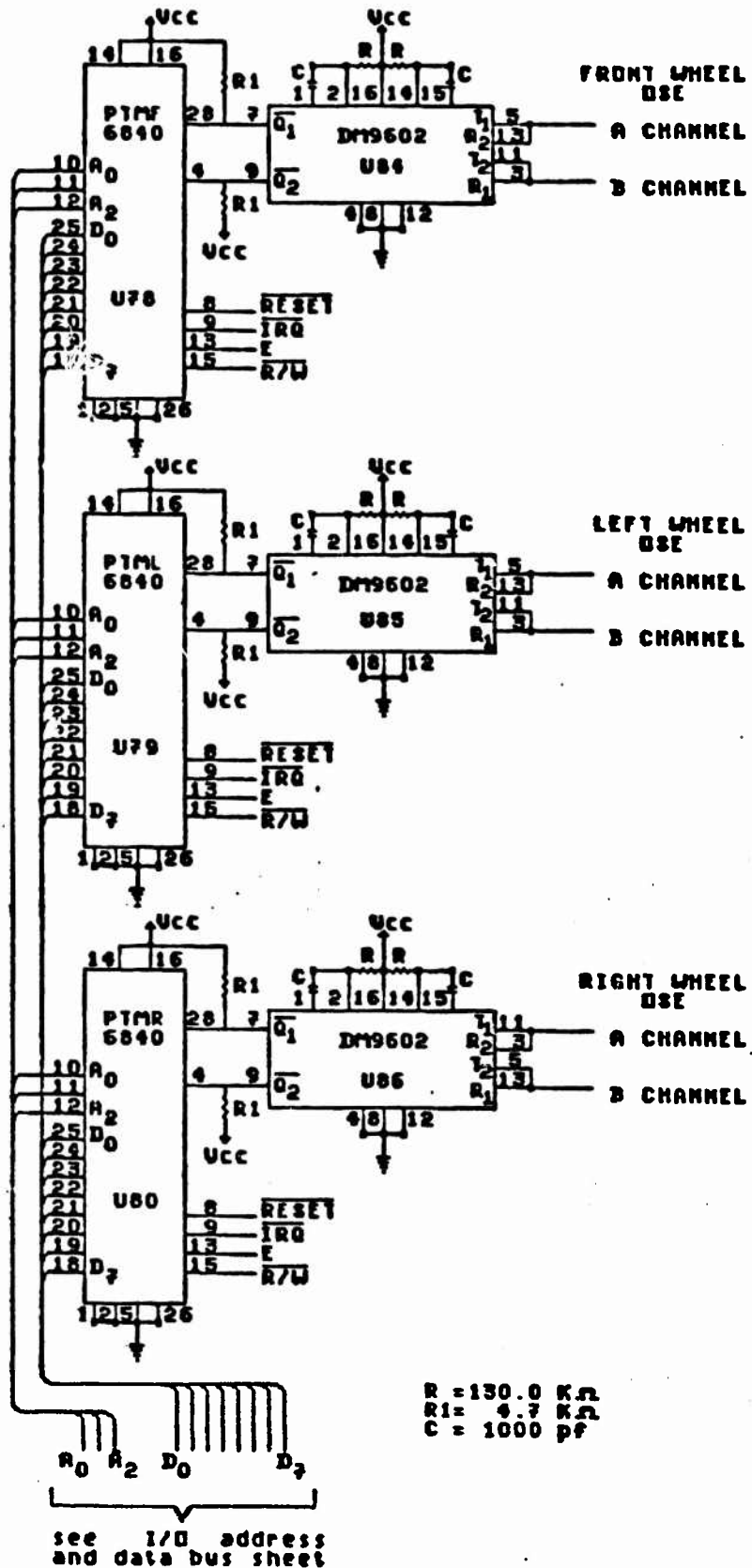

Fig. G.15 Optical Shaft Encoder Timer/Counter Circuit

C0	C1	C2	C4	C5	C6	D0	D1	D2	D4	D5	D6
13	14	15	16	17	18	19	20	21	22	23	24

12	11	10	9	8	7	6	5	4	3	2	1
B6	B5	B4	B2	B1	B0	A6	A5	A4	A2	A1	A0

Fig. G.16 24 Pin Sonar Transducer Header

VSW	6VDC	XLOG		GND	XMIT		MFLOG	6VDC	GND
20	19	18	17	16	5	4	3	2	1
1	2	3	4	5	16	17	18	19	20
GND	6VDC	MFLOG		XMIT	GND		XLOG	6VDC	VSW

Fig. G.17 Dual Sonar Range Board 20 Pin Header

D7	1	40	D6
D5	2	39	D4
D3	3	38	D2
D1	4	37	D0
	5	36	
	6	35	
RESET*	7	34	
IRQ*	8	33	
	9	32	
	10	31	R/W
A0	11	30	A1
A2	12	29	
	13	28	
	14	27	
	15	26	
	16	25	
	17	24	
	18	23	E
GND	19	22	
5VDC	20	21	

Fig. G.18 Optical Shaft Encoder Board 40 Pin Header

APPENDIX H

HERO-I TO MARRS-1 CONVERSION

CONTENTS OF APPENDIX H

FIG. H.1	DRIVE COMPUTER I/O UPGRADE.....	H-2
FIG. H.2	MARRS-1 BATTERY CONFIGURATION.....	H-2

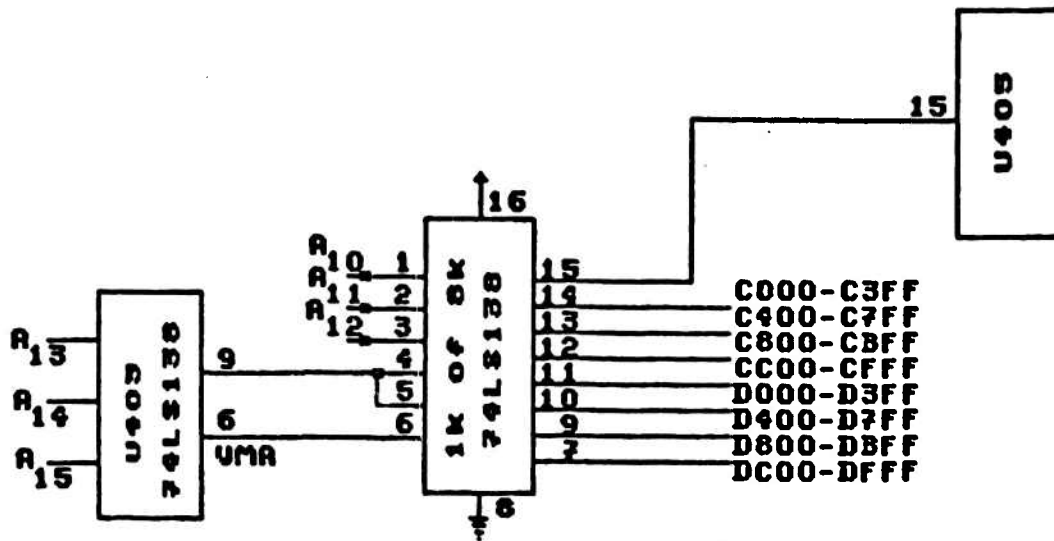

FIG. H.1 DRIVE COMPUTER I/O UPGRADE

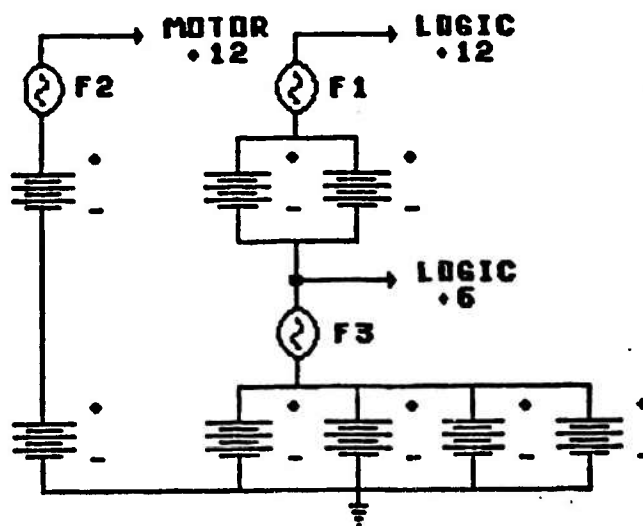

FIG H.2 MARRS-1 BATTERY CONFIGURATION

APPENDIX J

AFIT MOBILE ROBOTICS LABORATORY EQUIPMENT,
COMPUTER HARDWARE, AND SOFTWARE

EQUIPMENT

QUANTITY	DESCRIPTION
1	AFIT MARRS-1 ROBOT
2	WORK BENCH
1	SMALL TABLE
2	CHAIR WITH WHEELS
3	CHAIR
2	CHAIR, HIGH
1	TABLE, FOLDING
1	TABLE, EQUIPMENT
1	LAMP, DESK
2	LAMP, WORK BENCH
1	FAN
2	TRASH CAN
2	PAPER HOLDER, TYPIST
1	HP6236B POWER SUPPLY
1	BECKMAN 3010 UL DIGITAL VOM
1	BK 1570A OSCILLOSCOPE
1	ANDERSON-JACOBSON MODEM AD342
1	HP 1610A LOGIC STATE ANALYZER
1	RACAL-VADIC VA3414 1200/300 BAUD MODEM
2	STANDING BOOK CASE

COMPUTER HARDWARE

MARRS-1 NAVIGATION COMPUTER

MARRS-1 DRIVE COMPUTER

(MENOS I UPGRADE TO HERO COMPUTER BY VIRTUAL DEVICES)

HEATH H-89 COMPUTER

H-27 8 INCH DISK DRIVE SYSTEM

TRS 80 COLOR COMPUTER (64K EXTENDED BASIC)

5.25 INCH DISK DRIVE

TRS 80 COLOR MONITOR

TRS 80 CGP 115 COLOR GRAPHIC PRINTER

TRS 80 MULTIPACK INTERFACE

TRS 80 X PAD MODEL GT116

MOTOROLA 6800 EXORCISER COMPUTER SYSTEM

HEATH H125 DOT MATRIX PRINTER

COMPUTER SOFTWARE

WORDSTAR (EDITOR) BY MICROPRO INTERNATIONAL

MENOS I VAMP (ROBOT PROGRAMMING LANGUAGE BY VIRTUAL DEVICES)

ROBO C (C CROSS COMPILER FOR HERO ROBOT BY VIRTUAL DEVICES)

ROBO A (CROSS ASSEMBLER FOR HERO ROBOT BY VIRTUAL DEVICES)

MODEM 720 (PUBLIC DOMAIN COMMUNICATION PROGRAM)

TRS 80 EXTENDED COLOR DISK BASIC

OS-9 (OPERATING SYSTEM FOR TRS 80 COLOR COMPUTER)

BASIC09 (BASIC RUNNING UNDER OS-9)

APPENDIX K



Datametrics Inc., 340 Fordham Road, Wilmington, Mass 01887 • Tel (617) 658-5410 TWX 710-347-7672

K3 SERIES KIT ENCODER INSTALLATION INSTRUCTIONS (SQUAREWAVE VERSION)

1. MOUNTING ARRANGEMENT

Refer to Datametrics Dwg. B02537 for mounting surface arrangement. Note that (2) #4-40 X .18 deep tapped holes are called for. The two tapped holes are used to mount the kit encoder to the motor surface with #4-40 X 5/16 socket head screws.

Two #2-56 X 3/4 pan head screws are used to hold down the encoder cover. These screws thread into the encoder housing at the places indicated.

Note that an alternative mounting arrangement is possible. The two #4-40 mounting screws may be replaced by three #2-56 X 5/16 socket head screws located at the positions indicated on Dwg. B02537. In this case note that the two holes that are diametrically opposite in the encoder housing will have oversize clearance for #2-56 hardware. This clearance is reduced to appropriate size using the two fibre shoulder washers supplied with the unit.

2. INSTALLATION PROCEDURE

Step 1- INSTALL ROTOR/HUB ASSEMBLY

Slide rotor/hub assembly onto the shaft. A close sliding fit is desired. Excessive looseness can cause high rotor wobble. Slide the assembly to a position which will allow the rotor to enter the photohead gap with safe clearance both above and below the rotor disc. The bottom of the disc surface will be approximately 1/4" above the encoder mounting surface. Lightly tighten one hub set screw.

Note that the #4-48 hub set screws are much easier to handle if the hex wrench is held in a pin vise.

Step 2- INSTALL PHOTOHEAD ASSEMBLY

Slide the photohead assembly along the motor mounting surface so that the disc enters the photohead gap. Find the mounting hole locations and drop in the mounting screws. Be sure there is safe clearance above and below the disc. Tighten down the mounting screws. Note that the mounting hardware is easier to handle if a ball-tip Allen wrench is used.

Loosen the hub set screw and set the working air gap using the blue plastic shim. Insert the shim along the right side of the horseshoe opening as the opening faces you. Place the shim on top of the stator located on the upper right side of the horseshoe opening.

Step 3- ELECTRICAL CONNECTIONS

See Table 1.

Step 4- TEST ENCODER

Run the shaft at the desired speed and functionally test the encoder. The output signals' dc balance (symmetry) and quadrature phase relationship are factory set and should ordinarily not require adjustment. However, should finer trim be desired continue as follows: Adjustment pots are accessible on the photohead printed circuit board which allow a fine trim of the symmetry of the output signals. See Figure 2. The phase relationship of the output signals can be changed by movement of the photohead assembly on the mounting surface within the range of clearance around the mounting hardware. Both symmetry and phase adjustments described above can only be achieved while observing the output waveforms with an oscilloscope. See Figure 1.

CAUTION

ALWAYS APPLY DOWNWARD PRESSURE ON THE PHOTOHEAD ASSEMBLY WHILE ATTEMPTING PHASE ADJUSTMENT IN ORDER TO AVOID RUBBING THE DISC AGAINST THE STATOR.

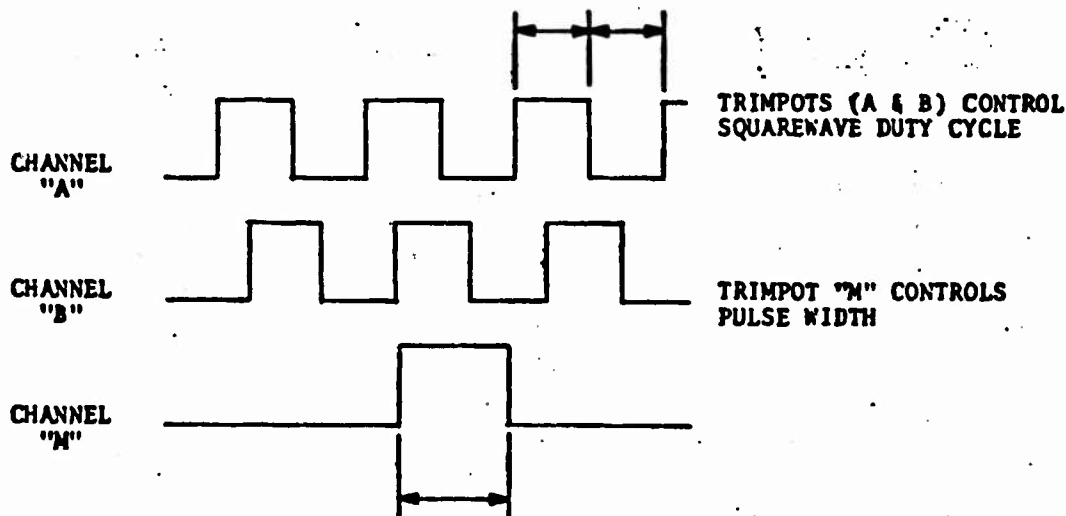

Figure 1 - Waveform Characteristics
(CCW rotation viewed from encoder end)

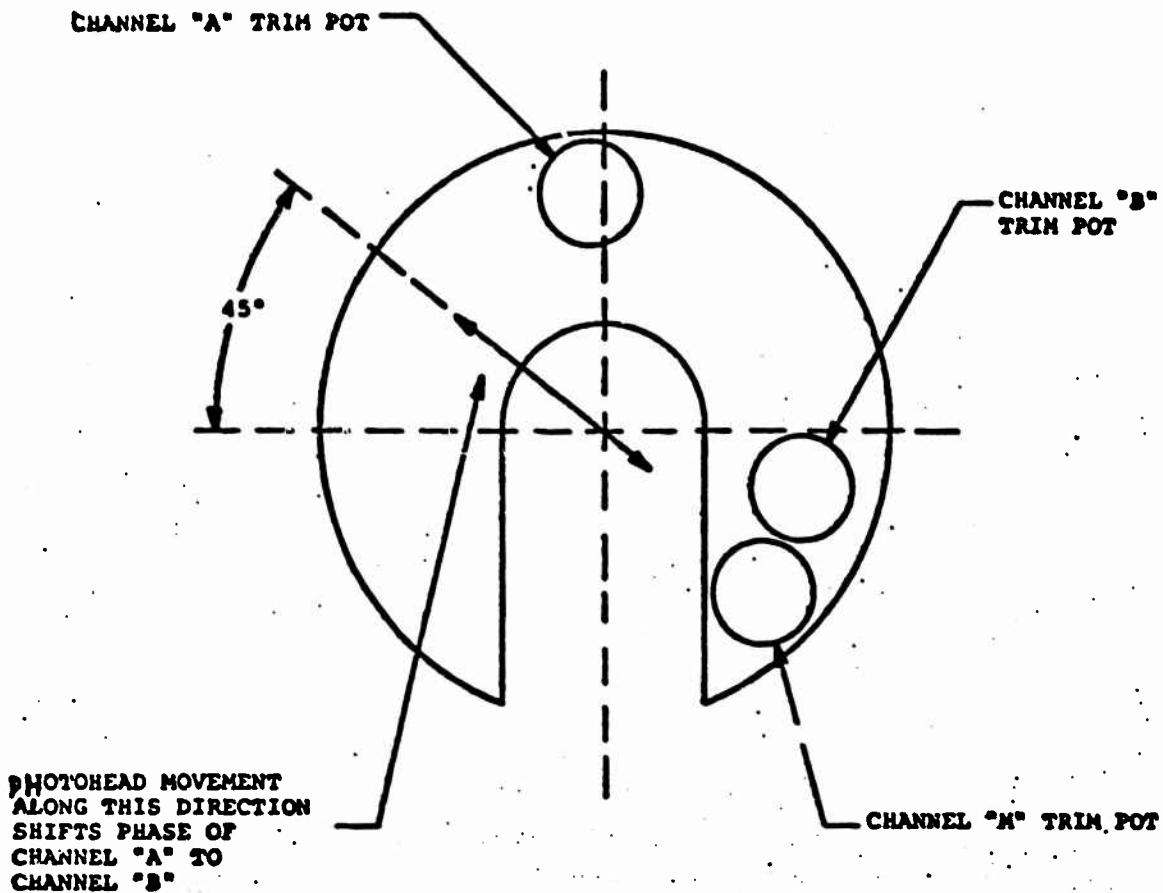

Figure 2 - Photohead Board Pot Layout

NOTE: The trim pots are factory set and glyptolled. They ordinarily should not require re-adjustment.

Step 5 - INSTALL COVER

Install cover over encoder using (2) #2-56 screws provided...Do not over tighten cover screws.

Table 1 - Electrical Connections

Wire Color	Function
Yellow	Output A
Blue	Output B
Orange	Output M
Red	+V
Black	Ground

APPENDIX L
POLAROID ULTRASONIC RANGING SYSTEM

Unmodified Ranging Circuit Board #606191
Modified Ranging Circuit Board #606745

TECHNICAL DATA

General Description:

The ranging module contains all necessary components to: generate the drive signal for the transducer; control timing functions; receive, amplify and filter the returned echo; and process this signal providing a step function output at the time of the received echo. The distance from the transducer to the target can then be computed with additional circuitry, knowing the speed of sound in air (or other gas), and the time interval between the transmit signal and the received echo as provided by the ranging module.

The #606745 board supplied with the designer's kit consists of a #606191 board which has had a six-wire, ribbon cable attached as shown on Figure 2 and has been modified as shown on Figures 4 and 5. The #606745 board does not have the transducer cable attached; however, this cable can be purchased from Polaroid by requesting Cable Assembly #604789.

Features:

Measurement range of 0.9 feet to 35 feet

Nominal resolution ± 0.12 inches to 10 feet
 $\pm 1\%$ over entire range

Multiple measurement capability

Drives Polaroid Electrostatic Transducer which requires 50kHz 300V signal with no additional interface.

Designed to operate with the Polaroid Instrument Grade Electrostatic Transducer #G04142.

Operation Conditions:

Supply Voltage	5.0 Vdc
Continuous Operating Current	250 mAmp
Peak Current During Transmit	2.5 Amp
Temperature Range	0 to 40 Deg. C.

Unmodified Ranging Circuit Board #606191
 Modified Ranging Circuit Board #606745

Schematic:

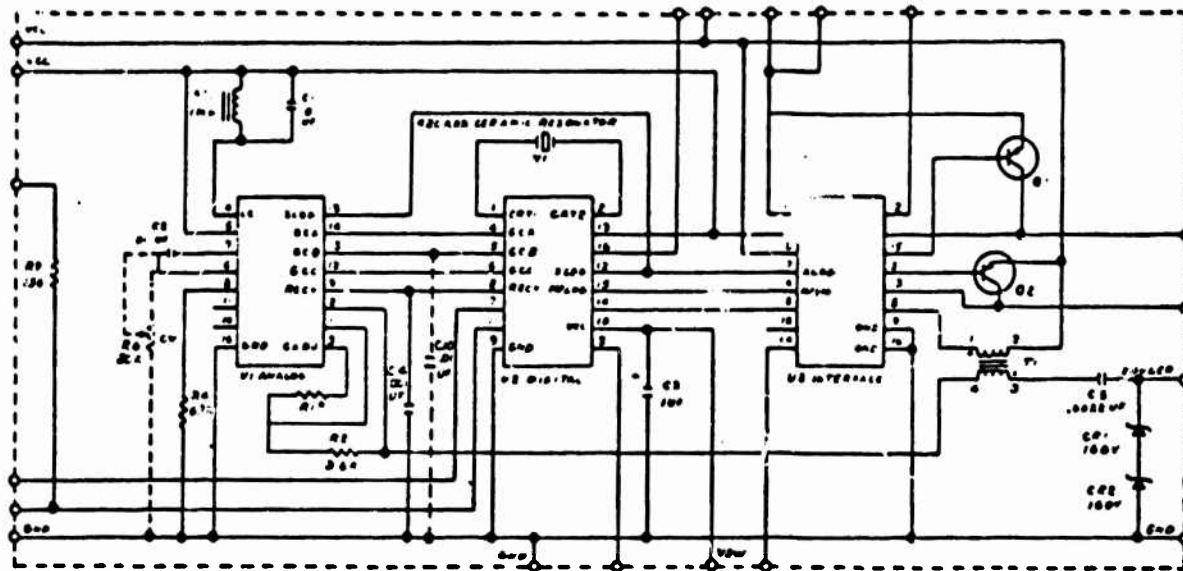

NOTES: 1. R1 is selected to set gain 2. R6 & C10 are only added if necessary at factory

FIG. 1

Interconnect Diagram:

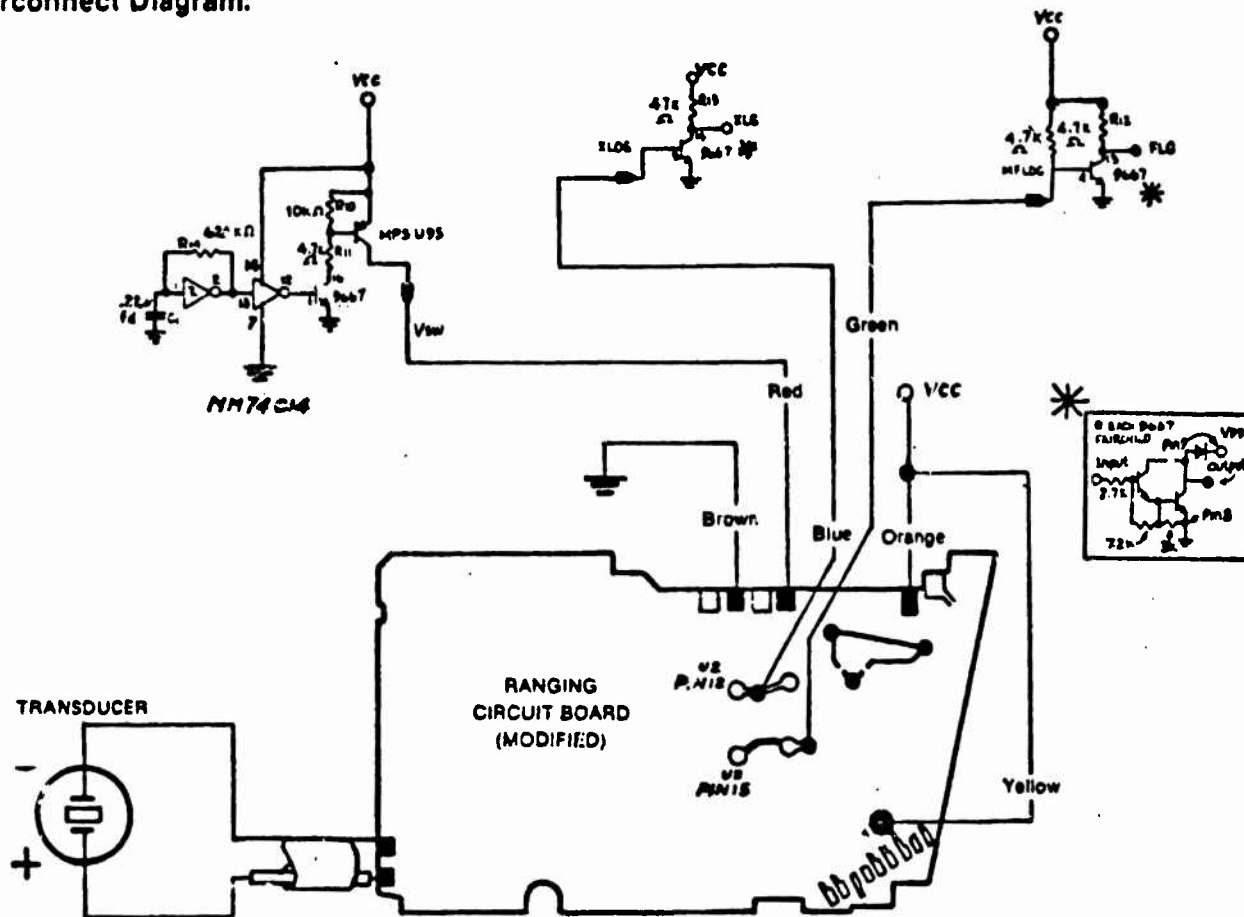

NOTE: Color Codes are for the ribbon cable supplied with #606745 Modified Ranging Circuit Board.

VCC (+) 60 Vdc
 25 Amps

FIG. 2

Unmodified Ranging Circuit Board #606191
 Modified Ranging Circuit Board #606745

Signal Description:

NAME	DESCRIPTION	Wire Color On #606745
VCC	Positive, Power Supply	Yellow & Orange
VSW	Starts a transmit/receive cycle when taken high Resets for next cycle when taken low	Red
XLOG	Transmit detect, use first falling edge after VSW high	Blue
MFLOG	Receiver detect, goes low when an echo is detected	Green
GND	Ground, power supply	Brown
XDUCER	Transducer input	—
GND	Transducer ground	—

Electrical Characteristics:

PARAMETER	MIN.	TYP.	MAX.	UNITS
Supply Voltage	4.9		6.8	Vdc
Continuous Operating Current			250	mAmp
Peak Current (during transmit)		2.5		Amp
VSW				
Vih	4.0		Vcc	Vdc
Iih	100			mA
Vil			0.4	Vdc
XLOG				
Voh	2.0			Vdc
Vol			0.8	Vdc
Iol			0.5	mA
MFLOG				
Voh	2.0			Vdc
Vol			0.8	Vdc
Iol			1.0	mA

Unmodified Ranging Circuit Board #606191
Modified Ranging Circuit Board #606745

Timing:

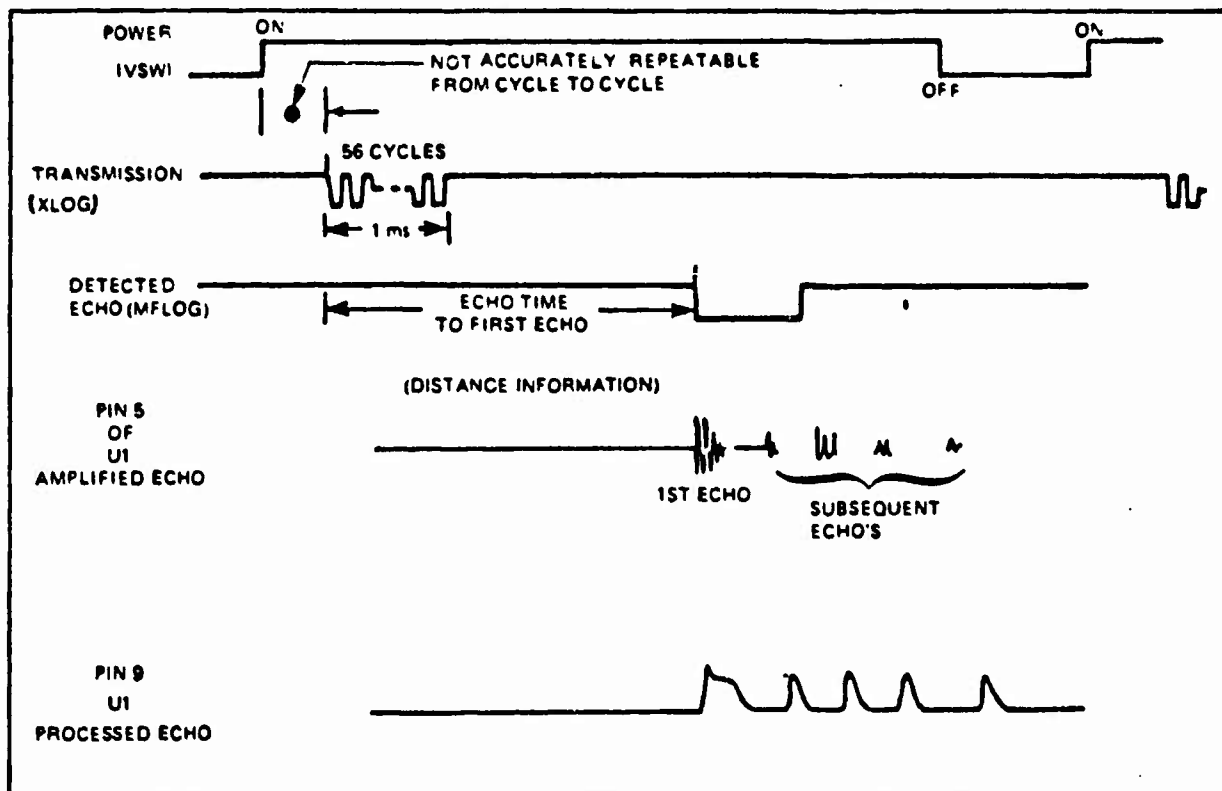

Unmodified Ranging Circuit Board #606191
 Modified Ranging Circuit Board #606745

Typical Relative Gain Bandwidth:

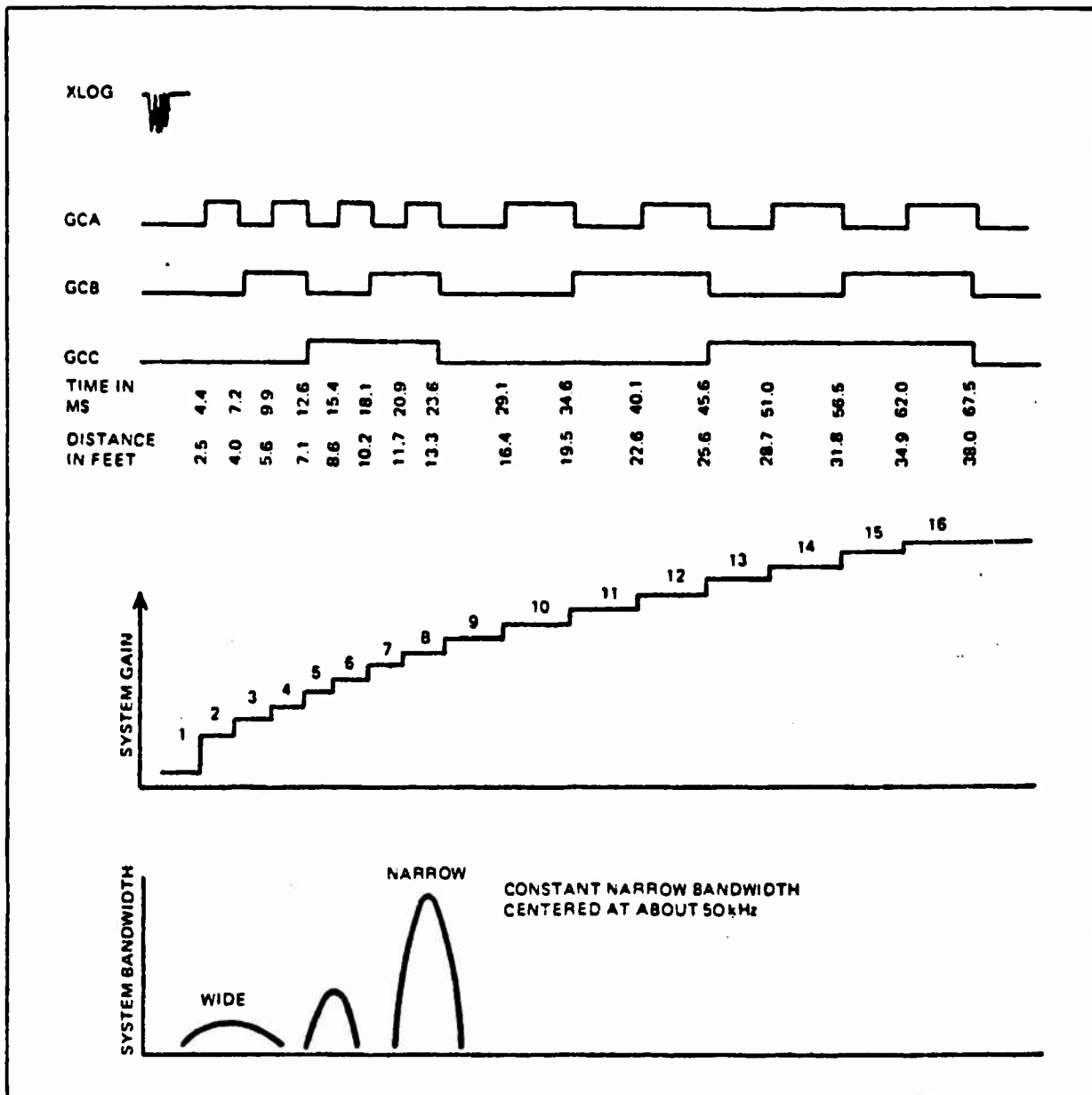

Unmodified Ranging Circuit Board #606191
 Modified Ranging Circuit Board #606745

Parts List:

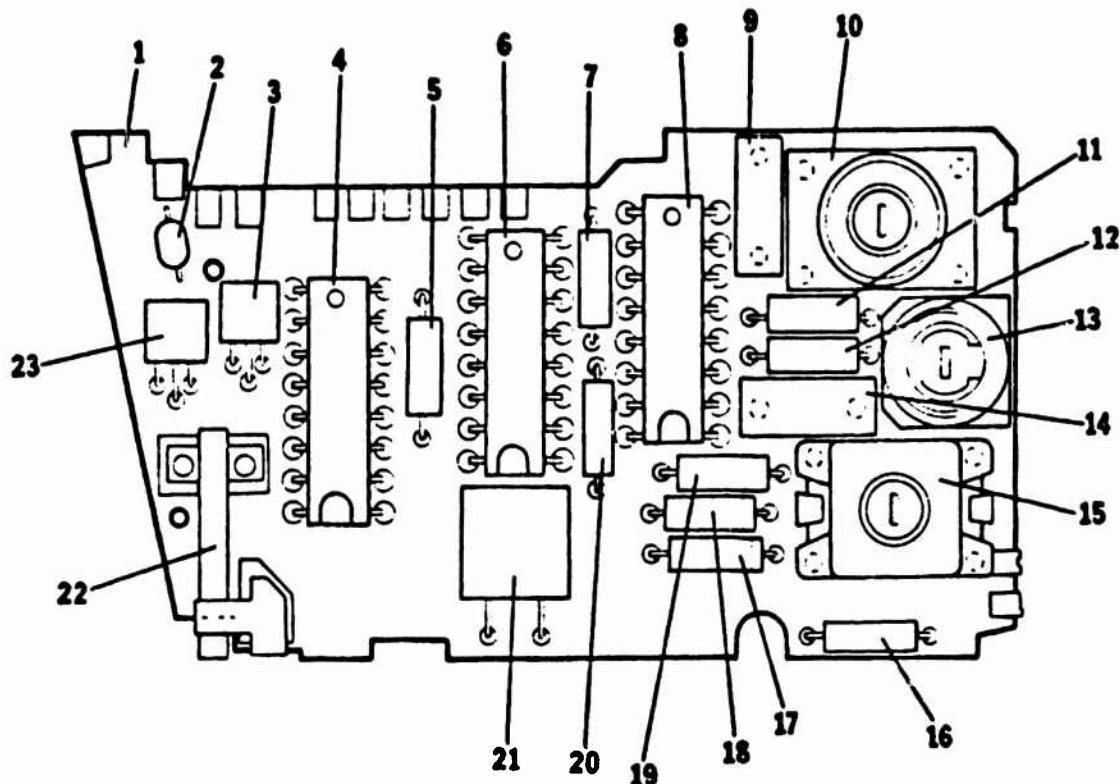

ITEM	REF.	DESCRIPTION
1		P.C. BOARD
2	C3	CAPACITOR 1 μ f, 35V
3	Q2	TRANSISTOR
4	U3	POWER IC
5	R9	RES. 150 Ω
6	U2	DIGITAL IC
7	C4	CAPACITOR .001 μ f, 10V
8	U1	ANALOG IC
9	C1	CAPACITOR .01 μ f, 10V
10	L1	TUNED CIRCUIT INDUCTOR
11	C2	CAPACITOR .01 μ f, 10V
12	R4	RESISTOR (62K, 5%, 1/4W)
13	R6	VARIABLE RESISTOR (25K, 1/4W) (See Note 2)
14	C5	CAPACITOR .0022 μ f, 400V
15	T1	TRANSFORMER
16	R1	RESISTOR (1-10K, 5%, 1/4W) See Note (1)
17	CR1	DIODE ZENER (IN4006)
18	CR2	DIODE ZENER (IN4006)
19	R2	RESISTOR (130K, 5%, 1/4W)
20	C10	CAPACITOR .01 μ f, 10V See Note (2)
21	XTAL	CRYSTAL 420 kHz
22	S1	SWITCH
23	Q1	TRANSISTOR

NOTE: 1. Resistor Value Set at Factory

NOTE: 2. Only Added If Necessary at Factory

Unmodified Ranging Circuit Board #606191
 Modified Ranging Circuit Board #606745

Dimensions

SIZE MAX DIM.
 3.025 IN. X 1.652 IN.
 X 0.520 IN.

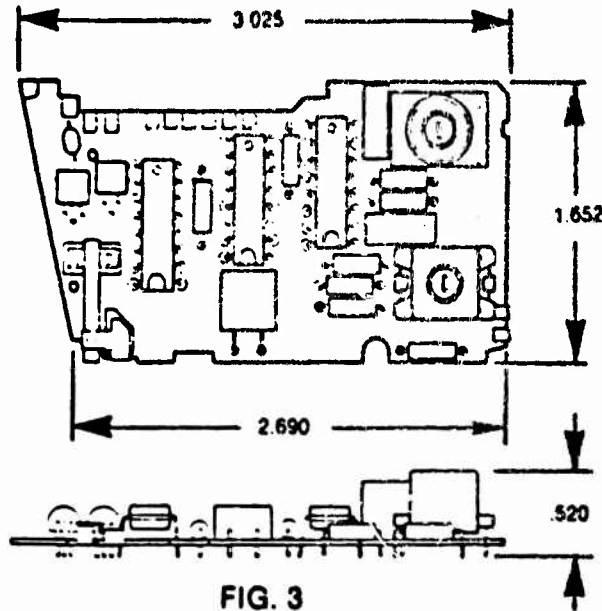

FIG. 3

Application Notes:

The ranging modules #606191 and #606745 are designed to function with the Polaroid Instrument Grade Transducer #604142.

Power the module through VCC. Next bring VSW high. The transmit burst of 56 pulses will begin approximately 5 msec later. The 56 pulses consist of 8 cycles at 60 kHz, 8 cycles at 56 kHz, 16 cycles at 52.5 kHz and 24 cycles at 49.41 kHz and lasts for a period of about 1.0 msec. Detected transmit can be observed at U2-12. The receiver is blanked for 1.6 msec. If an echo is not detected within 62.5 msec MFLOG will go high. Also if an echo is detected before 62.5 msec and after 1.6 msec MFLOG will go high.

Range information is determined by the time interval between the first falling edge of XLOG and the falling edge of MFLOG. The speed of sound in air is:

$$C = 331.4 \sqrt{\frac{T}{273}} \text{ M/Sec}$$

C = Speed of sound in air

T = Temperature in degree Kelvin

(Kelvin = Celsius + 273)

M = Meters

Sec = Seconds

To initiate another range measurement bring VSW low then high again while leaving VCC on.

The system (transducer and ranging module) gain is set to detect a 1.34 inch diameter sphere at 4 feet 3 inches on the acoustic axis.

If the ranging circuit board contains R6, adjustments are not recommended. R6 can change system gain and will change these specifications. If R6 is needed, refer to the parts list for installation location and specification. C2 will have to be relocated to the unused pad connected to the R6 wiper.

Unmodified Ranging Circuit Board #606191
Modified Ranging Circuit Board #606745

Modifications:

The Ultrasonic Circuit Board (#606745) included with the Ultrasonic Designer's Kit has been modified for use in ranging applications. Module #606191, ordered separately, will have to be modified by the purchaser to achieve the same performance. Other changes could be necessary for a particular application. Refer to the figure below to see how the ranging module #606191 must be altered to obtain performance similar to that of module #606745 in the kit. Make the alterations as follows:

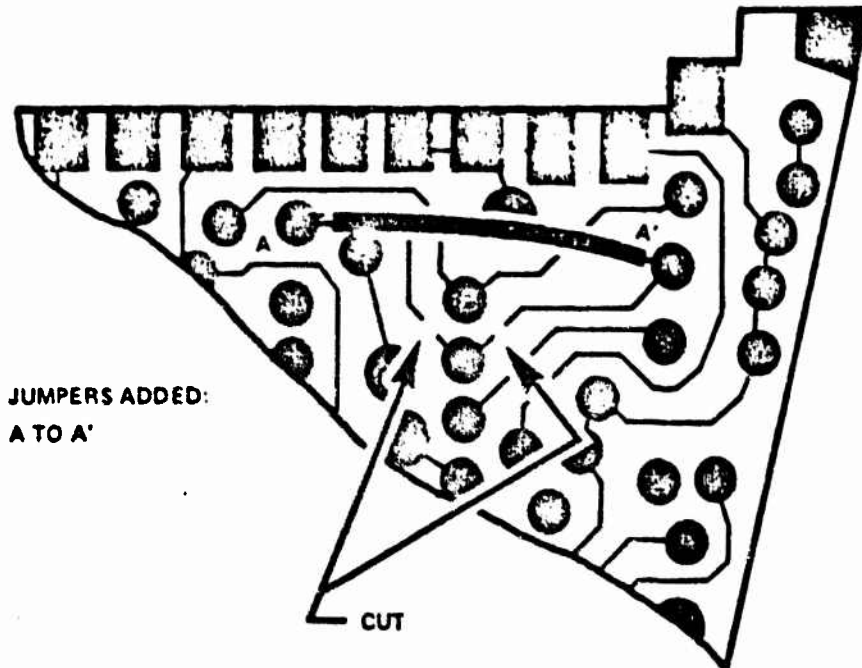

FIG. 4

- A. Cut the metallic circuit path on the board at the two points indicated by the arrows. Scrape the metal away or use any other effective method.
- B. Solder 1 jumper wire to the board as shown: between points A and A'.
- C. Cut switch as shown.



FIG. 5

For additional information or technical assistance contact:

Polaroid Corporation
Battery Division
784 Memorial Drive - 4A
Cambridge, Massachusetts 02139
(617) 577-4681

Specifications Subject
To Change Without Notice

BD-263 "Polaroid" and "Polapulse"®
Printed in U.S.A. 7/83

Appendix M

6800 Hex File Format

The 6800 Hex file format provides a compact representation of binary data patterns for transmission using ASCII communication terminals.

The Hex file is organized into data records with each record containing information in the same format. The record information consists of type, length, address, data and checksum. All records begin with an 'S' character for start of record identification. All information in the file which is not between a start of record and the checksum is ignored.

ditive summation (without carry) of the data bytes, the address, and the byte count.

Example Data Record

Memory Contents	
Address	Data
A000	10
A001	1A
A002	20
A003	2A

TAPE FORMAT

ASCII Character	Description
1	Start of record (S)
2	Type of record 0 - Header record 1 - Data record, 9 - End of file record.
3-4	Byte Count Since each data byte is represented as two hex characters, the byte count must be multiplied by two to get the number of characters to the end of the record. (This includes checksum and address data.)
5, 6, 7, 8	Address Value The memory location where this record is to be stored.
9, ..., N	Data Each data byte is represented by two hex characters.
N+1, N+2	Checksum The one's complement of the ad-

Data Record Contents

Character	Tape
1	Start of record 53 S
2	Type of record 31 1
3	Byte count 30 0
4	37 7
5	41 A
6	30 0
7	Address 30 0
8	30 0
9	Data byte 1 31 1
10	30 0
11	Data byte 2 31 1
12	41 A
13	Data byte 3 32 2
14	30 0
15	Data byte 4 32 2
16	41 A
17	Checksum 38 8
18	34 4

Checksum

Byte Count * 2

The format for all hex file records is diagrammed below.

Character		Header Record		Data Record		End-of-File Record	
1	Start of Record	53	S	53	S	53	S
2	Type of Record	30	0	31	1	39	9
3	Byte Count	31	12	31	16	30	03
4		32		36		33	
5	Address (if any)	30	0000	31	1100	30	0000
6		30		31		30	
7		30		30		30	
8		30		30		30	
9	Data	34		39		46	FC
10		38		38	98	43	
.		34		30	02		(Checksum)
.		34		32			
.		35		.			
.		32		.			
.				41			
.				48	A8 (Checksum)		
N	Checksum	39					
		45	9E				

APPENDIX M

NAVIGATION COMPUTER SOFTWARE USER'S MANUAL

(EXTRACTED IN PART FROM AMERICAN MICROSYSTEMS 6800 PROGRAMMING MANUAL.)

THE NAVIGATION COMPUTER SOFTWARE IS COMPRISED OF THE MIKBUG AND PROTO OPERATING SYSTEMS, A ROM SUBROUTINE LIBRARY (RS)3, A SYSTEM HARDWARE INITIALIZER, AND A SYSTEM MASKABLE INTERRUPT HANDLER. MIKBUG IS SELDOM USED EXCEPT BY SPECIAL COMMERCIAL SOFTWARE SUCH AS BASIC INTERPRETERS. THE PROTO OPERATING SYSTEM RESPONDS TO THE COMMANDS DESCRIBED IN THE FOLLOWING PARAGRAPHS. A COMMAND CONSISTS OF A ONE CHARACTER COMMAND IDENTIFIER FOLLOWED BY ADDITIONAL PARAMETERS IF NEEDED, SEPERATED BY BLANKS OR COMMAS. ALL COMMANDS END WITH A CARRIAGE RETURN. SINCE NO ACTION IS TAKEN BEFORE THE CARRIAGE RETURN, AND INPUT LINE MAY BE DELETED BY USE OF THE ESCAPE KEY. (PAPER TAPE AS A STORAGE MEDIA IS MENTIONED IN THE FOLLOWING PARAGRAPHS. IT SHOULD BE INTERPRETED AS THE DEVICE OR MEDIA WHICH IS USED TO STORE AND RETRIVE DATA IN THE ROBOT TO EXTERNAL COMPUTER SYSTEM.)

L, ADDL, ADDH, OFFSET

The Load file command loads data from a hex formatted file. (see Appendix M) into the user's memory between ADDL and ADDH, inclusive. The OFFSET is added to the memory address specified on the tape to form the actual memory starting address for the data stored. If a byte to be stored into memory has an address outside of the range ADDL, ADDH, it is not entered into memory, but a Delete character (H'FF) is transmitted to the terminal.

Example: L 0100 02FF FFFA

The address range in the L command is optional, and if omitted is assumed to be the full range of memory (0000-FFFF). The offset parameter is also optional, and if omitted is assumed to be zero (0000). Thus the L command with no parameters loads the tape into the memory locations specified on the tape with no offset. The offset value in the L command is a two's complement signed number, entered in unsigned hexadecimal. For example, an offset of -6 is entered as FFFA.

If an attempt is made to load non-existent memory, or ROM, the loading operation will terminate, typing out the address and the message "BAD ADR".

In operating the Load command, PROTO goes into a receive md and scans the file for the first ASCII "S", which indicates start of record. It is not necessary to position the file at the first record of a file since each record contains its own starting address.

PROTO will load data records until it encounters an end of file (EOF) record or a file error (Check Sum or illegal character). When PROTO reads a header record (start of record and address), it translates the header into ASCII characters and prints the result. The Check Sum is the binary sum of all characters in the block.

PROTO does not list the file contents as the file is being read.

When PROTO encounters an end of file record or a file error, it turns off the reader and prints "EOF" or "CKSM ERR" respectively.

P, ADDL, ADDH, OFFSET

The put hex file command causes PROTO to create a hex file of the contents of memory between ADDL and ADDH, inclusive. Each record is created with a four-digit hex address of the starting byte of the record. This address is derived from the memory address of the byte being filed , plus the offset value, OFFSET. The offset is optional, and if omitted is assumed to be zero.

Records using this command (except the last record) contain 16 bytes of data plus the start code, byte count, address, and the checksum. The P command does not cause an EOF record to be created so that several disjoint blocks of memory can be combined into one file.

Example: P F000 F07F 0F00

S, ADDR, BYTE1, BYTE2, ---, BYTEN

The Set memory command writes the 8-bit data words specified by BYTE1 to BYTEN into consecutive memory locations starting at ADDR. If ADDR has more than 4 (hexadecimal) characters or if any of the data bytes have more than 2 characters each, only the last 4 or 2 characters are used respectively.

Example: S 0000 86 05 97 28

Memory locations at 0000 thru 0003 are loaded as shown.

D, ADDL, ADDH

The Display memory command prints the contents of memory between ADDL and ADDH, inclusive, in hex format. Up to sixteen bytes per line are printed, preceded by the hexadecimal address of the first byte of the line.

G, ADDR

The Go command starts execution of the user program at the address specified by the input parameter. To insure that all registers contain the same information they held before the user program was interrupted, PROTO pushes into the stack the copy of the user registers that it keeps at locations BFEA-BFF2 (CC, B, A, X, P, S) then executes an RTI instruction. The user can change the initial values of the registers by changing the contents of these locations.

Example: G 300

Program will branch to address 0300 and start execution from that point.

R

The Registers command prints the contents of memory locations BFEA-BFF2 which contain the values that were in the user's C, B, A, X, P, and S registers (in that order) when the user's program was last interrupted.

M, ADDL, ADDH, DEST

The Move command copies memory from the range ADDL - ADDH, inclusive, to the RAM locations starting at DEST. This copy begins at the lower address, so if DEST lies within the range ADDL - ADDH, some of the original data will be lost, and other parts will be duplicated.

E

The End of Transmission command is used to cause an EOT character to be punched on the paper tape. After a field has been punched, an EOT will terminate the record and punch a trailer tape. When reading a record, the reader will stop at the EOT character. If no EOT character is present, the reader must be manually turned off and the Reset switch must be pressed to enter the operating system program.

C
Cold start at address 0100H in the system. Presently this has the effect of executing the extended interrupt handler that was loaded into RAM from ROM during power-up. Data from the optical shaft encoders and the four sonar range boards are sent thru the terminal serial port of the navigation computer to whatever device is connected to it at 9600 baud. (The extended interrupt handler, when active, will respond to the following commands:

Control S Stop sending data.
Control Q Resume sending data.
Control C Restart Nav computer.
1 Select sonars 1 at a time. 2
Select sonars 2 at a time. 3 Select
sonars 3 at a time. 4 Select sonars
4 at a time.) If the ROM located at U7 is replaced with a ROM containing a 6800 BASIC interpreter then a cold start of BASIC is made.

W
Warm start at address 0103H in the system. This command is only effective if the ROM located at U7 is replaced with a ROM containing a 6800 BASIC interpreter. However, PROTO will jump to address 0103H any time this command is given irregardless of the contents of that location.

Q
Odyssey command. Causes PROTO to jump to address 02001H in the system.

INTERRUPTS

Of the four available interrupt vectors, RESET and SWI are used by PROTO. IRQ is used by the Sonar/Optical Shaft Encoder/Tic Time system. NMI is not used and is available for future designs. All interrupt vectors are in RAM except RESET so that a program can reconfigure the interrupt structure. A hardware RESET always returns the user to the PROTO operating system after a hardware initialization and ROM to RAM overlay has been performed.

The upper memory locations are ROM. If the user expects either NMI or IRQ interrupts to occur, he may reinitialize the vector addresses to the starting address of his IRQ and NMI handler routines by changing addresses BFF7-BFFF.

PROTO must have control of the RESET vector so that the RESET switch on the Prototyping Board can return program control to PROTO at any time.

The reset routine copies the contents of the B, A, X, CC, and S registers into a fixed area of memory. This means that the program can be aborted at any time by using the reset switch while still saving all the registers except the program counter. Unfortunately, the contents of the program counter are lost.

It is possible for the user to use the NMI interrupt to abort a program execution without losing the contents of the P and C registers. This condition is automatically set in the NMI handling routine when PROTO is called. This interrupt vector will cause the contents of the user's registers to be printed when the $\overline{\text{NMI}}$ lines goes low.

Since the SWI instruction is used to call sub-routines between 00 and H'18 from (RS)³ as described later in "The Subroutine ROM", the user is somewhat limited in the ways he can use SWI instructions. However, he can access an SWI handler routine in his own program by an SWI instruction followed by a byte containing the decimal number less than H'80 but greater than H'19 < n < H'80 sequence, PROTO passes control at address BFF3. If the user expects to access his own SWI routine and use PROTO, he must use the Set Memory command to store the address of this routine at location BFF3 and BFF4.

PROTO makes sure that the user's SWI routine is entered from the stack with all registers containing the same information that they would hold if the routine were entered directly through the SWI vector.

EXTENDED INTERRUPT HANDLER

The extended interrupt handler that was loaded into RAM from ROM during power-up sends data from the optical shaft encoders and the four sonar range boards thru the terminal serial port of the navigation computer to whatever device is connected to it at 9600 baud. The extended interrupt handler becomes active when the Cold command is given from PROTO. The Nav computer will then respond to the following commands ONLY:

Control S Stop sending data.
Control Q Resume sending data.
Control C Restart Nav computer.
1 Select sonars 1 at a time. 2
Select sonars 2 at a time. 3 Select
sonars 3 at a time. 4 Select sonars
4 at a time.

THE SUBROUTINE ROM

Many of the monitor's functions are accomplished with the help of the Re-Entrant Self-Relative Subroutine ROMs (RS)². This standard ROM, which can be considered a software extension to the 6800 instruction set, is also available to be used by the user both on the prototype board and in his final production system. The user can call one of the 25 (RS)² subroutines with an SWI instruction followed by the number of the desired subroutine. The details of the subroutines available in the (RS)² user's manual.

The user should be aware of the fact that the (RS)² pushes from 7 to 10 bytes of data onto the stack, depending upon which subroutines are called. This means that if the user calls (RS)² routines, he must make sure that the necessary memory space is available for stack expansion.

Since PROTO assigns its own stack area, the user need not be concerned about how (RS)² is used.

BREAKPOINTS

Breakpoints allow the user to halt his program and examine the contents of the internal registers. PROTO provides two types of breakpoints. In this system, breakpoints are actually debugging routines that can be called from the user's program just like (RS)² routines.

Each breakpoint requires a two byte calling sequence: an SWI instruction followed by a number.

Breakpoints may be inserted either by reassembling the program with the extra SWI instructions added the Set Memory command may be used to replace parts of the code with SWI instructions. Note that the second method is not satisfactory for the snapshot option (described below) since the replaced code must be restored before execution can be continued. When using the second method, the user must make sure that he replaces the first two bytes of an instruction. If the SWI replaces the second or third byte of an instruction, it may be interpreted as an address rather than an opcode.

The different types of breakpoints are:

1. Print registers (SWI, H'80)
2. Snapshot (SWI, H'81)

The sequence SWI, H'80 saves the user's registers at the vector stored in BFF1-BFF2, prints their contents (in the order CC BB AA XXXX PPPP SSSS), then returns control to PROTO.

The sequence SWI, H'81 prints out the contents of the user's registers then continues executing the user's program starting at the address following the byte containing the number H'81. Note that if this address does not contain a valid opcode, unpredictable results will occur.

Reentrant Self-Relative Subroutine ROMs (RSRSRS) = (RS)³

The cost of microprocessor software development is many small items: the cost of assembly time, storage time, transmission time, loading time, design, development, documentation and debug. The cost of many of these items continues to accumulate even though a subroutine library exists for common functions, in particular the time and cost of transmission, loading and ROM pattern generation.

The purpose of Reentrant Self-Relative Subroutine ROMs (RS)³ is to give the user a hardware subroutine package which exists in the breadboard design from the beginning. The programs are documented, debugged and constitute some of the most commonly performed subroutines that assembly language programmers generate. The subroutines are not complex and are not intended to be. Any subroutine could easily be reproduced by a user; however, the intention is that the routine exists now and the user does not have to reproduce it. The routines tend to be slow because of their generality but the intention is immediate availability. If a particular program is time critical, it can be regenerated later when the time critical elements are known.

CONCEPTS

The (RS)³ uses a number of concepts to allow flexibility in the user environment. The first concept is self-relative programming. This simply means that the program will function correctly regardless of where it is located in memory. The user will need to know where it is located so he can reference it. However, this actual location will only have to be recorded once. The self-relative program uses relative address instructions for program control and the index and stack pointer instructions for data manipulation.

The stack is used for temporary storage of data to prevent (RS)³ from being tied to fixed addresses. This allows the program to be reentrant; i.e. the program can be called at different times without completing the previous call. This means that the same routine can be called by the interrupt processor as well as by the program which was interrupted. The concept of reentrant code is not to be confused with recursive code; even though recursive coding could have been used in the subroutine package, it is not.

The subroutine calling mechanism uses the SWI instruction followed by a single byte index for the particular subroutine invoked. This was chosen because the SWI is the most convenient from an internal programming viewpoint and the safest. It is safe because an error in a ROM can be corrected by replacing the subroutine ROM without altering any other user ROM. If direct addresses to subroutine code exist in the user's domain, his ROMs would change if the location of the routine in the (RS)³ changed.

IMPLEMENTATION

The user places the base address of the (RS)³ into the SWI vector address. Each SWI instruction requires an index byte to follow the SWI instruction where the index indicates the function to be executed. After the function is performed, the user program will continue with the instruction following the index byte. In essence, a whole new set of instructions have been created for the user which are two bytes long.

To make the entry easier, a macro call can be provided which will assemble the correct index byte when the function name is used. A set of EQU assembler commands associates the name and the index byte value.

(RS)³ IN PROTO – SUBROUTINE DESCRIPTIONS

Each of the subroutines in the ROM are described here, giving the index for the call, a mnemonic subroutine name, a descriptive title, and the number of bytes in the stack used by the call (including the SWI). A brief description of the subroutine operation is also given, with the entry requirements, the exit conditions, and the registers altered by the subroutine. Only those registers indicated are altered by any (RS)³ subroutine.

Index	Name	Title	Stack Bytes
-------	------	-------	-------------

00	PUSH ALL	Push All Registers	14
----	----------	--------------------	----

Five bytes are pushed onto the stack, containing, respectively, the Condition Codes, the B and A accumulators, and the Index Register. No registers are altered (except the stack pointer, which is decremented by 5).

Entry: Any

Exit: Stack: SP +1 +2 +3 +4 +5 (=old SP)
CC, B, A, XHXL

Registers Altered: SP

01	POPALL	Pop (=Pull) All Registers	9
----	--------	---------------------------	---

Five bytes are pulled from the stack into the Condition Codes, the B and A accumulators, and the Index register, respectively. The Stack Pointer is incremented by 5.

Entry: Stack, as by PUSH ALL

Exit: CC, B, A, X pulled from stack

Registers Altered: CC, B, A, X, SP

02	TXAB	Transfer Index Register to A and B	9
----	------	------------------------------------	---

The most significant eight bits of the index register are copied to the A accumulator, and the least significant eight bits are copied to the B accumulator.

Entry: Any

Exit: A, B loaded from X

Registers Altered: A, B

Index	Name	Title	Stack Bytes
-------	------	-------	-------------

03	TABX	Transfer A and B to Index	9
----	------	---------------------------	---

Accumulator A is copied to the most significant byte position of the index register, and accumulator B is copied to the least significant byte position of the index register.

Entry: Any

Exit: X loaded from A, B

Registers Altered: X

04	XABX	Exchange A and B with Index	12
----	------	-----------------------------	----

The contents of the Index register and the two accumulators are exchanged, A with the most significant byte of X, B with the least significant byte.

Entry: Any

Exit: A, B and X exchanged

Registers Altered: A, B, X

05	PUSHX	Push Index Register	11
----	-------	---------------------	----

The contents of the index register is pushed onto the stack. The Stack Pointer is decremented by two.

Entry: Any

Exit: Stack: SP +1 +2 (=old SP)
XH XL

Registers Altered: SP

06	PULLX	Pop (=Pull) Index Register from Stack	9
----	-------	---------------------------------------	---

Two bytes are pulled from the stack into the index register, and the stack pointer is incremented by two.

Entry: Two bytes on stack

Exit: X pulled from stack

Registers Altered: X, SP

Index Name	Title	Stack Bytes
------------	-------	-------------

07 ADDXAB Add Index to A and B 14

Add the contents of the Index Register to the two accumulators, as a 16-bit sum, leaving the result in the two accumulators. The most significant byte is assumed to be in accumulator A. The condition codes are set according to the result.

Entry: Addend in X, augend in A, B

Exit: Sum in A, B

Condition

Codes: H = carry from bit 11 to bit 12 of sum
 N = bit 15 of sum
 Z = 1 if sum is zero; else = 0
 V = 1 if two's complement overflow
 C = carry out of bit 15 of sum

Registers Altered: A, B, CC

08 ADDABX Add A and B to Index Register 9

Add the contents of the two accumulators to the Index register, leaving the 16-bit sum in the index register. Accumulator A is assumed to be more significant than accumulator B. The condition codes are set according to the result.

Entry: Addend in A, B; augend in X

Exit: Sum in X

Condition Codes: H = carry from bit 11 to bit 12 of sum
 N = bit 15 of sum
 Z = 1 if sum is zero, =0 otherwise
 V = 1 if two's complement overflow
 C = carry out of bit 15 of sum

Registers Altered X, CC

Index Name	Title	Stack Bytes
------------	-------	-------------

09 ADDAX Add A to Index Register 9

Add the A accumulator to the contents of the Index register, and return the sum to the index register. The Condition Codes are set according to the result.

Entry: Addend in A, augend in X

Exit: Sum in X

Condition

Codes: (Same as ADDABX)

Registers Altered: X, CC

0A ADDBX Add B to Index Register 9

Add the contents of the B accumulator to the Index register, and leave the sum in the Index register. The Condition Codes are set according to the result.

Entry: Addend in B, augend in X

Exit: Sum in X

Condition

Codes: (Same as ADDABX)

Registers Altered: X, CC

0B SUBXAB Subtract Index from A, B 14

Subtract the contents of the index register from accumulators A and B as a 16-bit difference. The Condition Codes are set according to the result.

Entry: Subtrahend in X, minuend in A, B

Exit: Difference in A, B

Condition

Codes: H = undefined
 N = bit 15 of difference
 Z = 1 if result is zero, =0 otherwise
 V = 1 if two's complement overflow
 C = borrow into bit 15 of difference

Registers Altered: A, B, CC

Index Name	Title	Stack Bytes
------------	-------	-------------

0C	SUBABX	Subtract A and B from Index Register	9
----	--------	--------------------------------------	---

Subtract the contents of the A and B accumulators from the Index register, leaving the difference in the Index. The Condition Codes are set according to the result.

Entry: Subtrahend in A, B; minuend in X

Exit: Difference in X

Condition

Codes: (Same as SUBXAB)

Registers Altered: X, CC

0D	SUBAX	Subtract A from Index Register	9
----	-------	--------------------------------	---

Subtract the contents of the A accumulator from the contents of the Index register and return the difference to the index register. The Condition Codes are set according to the result.

Entry: Subtrahend in A, minuend in X

Exit: Difference in X

Condition

Codes: (Same as SUBXAB)

Registers Altered: X, CC

0E	SUBBX	Subtract B from Index Register	9
----	-------	--------------------------------	---

Subtract the contents of the B accumulator from the Index register, leaving the difference in the index register. The Condition Codes are set according to the result.

Entry: Subtrahend in B, minuend in X

Exit: Difference in X

Condition

Codes: (Same as SUBXAB)

Registers Altered: X, CC

Index Name	Title	Stack Bytes
------------	-------	-------------

0F	P2HEX	Print Byte in Hex	15
----	-------	-------------------	----

The byte pointed to by the address in the Index register is converted to hexadecimal notation in ASCII, and output to the ACIA located as follows: memory locations BFF5-BFF6 contain an address of a pair of bytes (indirect pointer) which in turn contain the address of the ACIA status register.

BFF6

iL

BFF5

iH

...

j+1

aL

i

aH

...

a+1

ACIA Data

a

ACIA Status

Each byte of the output is stored into the ACIA data register after bit 1 of the Status register is true. The Control register of the ACIA is not altered, and the Data register is not read by this routine. The Index register is incremented past the byte which is output.

Entry: Memory byte at (X); ACIA at (BFF5)

Exit: (two ASCII bytes output)

Registers Altered: X

10	P4HEX	Print Address in Hex	15
----	-------	----------------------	----

The two bytes in memory pointed to by the Index register are converted to four ASCII digits and output to the ACIA located at the address pointed to by the pointer pointed to by the byte pair at BFF5-BFF6 (see P2HEX). The Index register is incremented by two.

Entry: Two bytes at (X); ACIA at ((BFF5))

Exit: (four ASCII bytes output)

Registers Altered: X

11	PRINTA	Print the Byte in A	10
----	--------	---------------------	----

The byte in accumulator A is output to the ACIA, the address of whose address is in locations BFF5-BFF6. No registers are altered except the ACIA data register.

Entry: Character in A

Exit: (one byte output)

Registers Altered: None

Index Name	Title	Stack Bytes
------------	-------	-------------

12 PMSG Print Message String 12

A message string, the first byte of which is pointed to by the Index register, is output to the ACIA, the address of whose address is in locations BFF5-BFF6. The string is terminated by an ASCII EXT (=hex 04), and the Index register is left pointing to that byte on return.

Entry: Character string to (X) terminated by 04; ACIA at ((BFF5))

Exit: (in ASCII bytes output), X pointing to 04 byte

Registers Altered: X

13 VALAN Validate AlphaNumeric 11

The character pointed to by the Index register is analyzed, and the Carry flag is set if it is a letter or digit; if it is not a hexadecimal digit, the Overflow flag is set. Other than the condition codes, no registers are altered.

Entry: Memory byte (ASCII) at (X)

Exit: Condition

Codes: H = undefined
 N = undefined
 Z = 0
 V = 0 if character in range 0-9, A-F; else = 1
 C = 1 if character in range 0-9, A-Z; else = 0

Registers Altered: CC

14 INPUTA Input ACIA byte to A 9

One byte is input from the ACIA, the address of whose address is at location BFF5-BFF6, and this byte is returned to accumulator A. The ACIA is not written to, and except for the A accumulator, no registers are changed. (RS)³ samples bit 0 of the status register of the ACIA, and when it goes to one, reads the data register. The input byte has bit 7 removed (set to zero).

Entry: (one byte input)

Exit: Character in A, bit 7=0

Registers Altered: A

Index Name	Title	Stack Bytes
------------	-------	-------------

15 CONHB Convert Hex String to Binary 11

A string of characters in memory beginning at the address in the index register is scanned for valid Hexadecimal digits; when one is found, it and all immediately following hex digits are converted to a binary number, which is left in the A and B accumulators (A is more significant). When this routine is called, the maximum length of the string is in the B accumulator. On exit, the Carry flag is set to one if the conversion resulted in a valid binary number, and the index register is left pointing to the next character in the string, or if the string is exhausted before finding any hex digits, to the last character of the string.

Entry: Character string (including ASCII hex number) at (X)

Max string length in B (<128)

Exit: Binary number in A, B

Condition

Codes: H = undefined
 N = undefined
 Z = undefined
 V = undefined
 C = 1 if valid number; = 0 if not

Registers Altered: A, B, X, CC

16 INDEX Multiply A X B and Add to Index 12

The contents of the A accumulator is multiplied by the contents of the B accumulator, and the product is added to the Index register. The Condition Codes are set according to the result.

Entry: Multiplicand in A, Multiplier in B, augend in X

Exit: Sum in X

Condition

Codes: (Same as ADDABX)

<u>Index</u>	<u>Name</u>	<u>Title</u>	<u>Stack Bytes</u>
--------------	-------------	--------------	------------------------

17	MUL8	Multiply A Times B	12
----	------	--------------------	----

Multiply the contents of the A accumulator times the contents of the B accumulator, and leave the product in both accumulators as a 16-bit number, with the most significant part in A. This is an unsigned multiply, and if either or both of the factors is negative (two's complement signed) the product will not be a true signed product of the signed factors, as may be seen in this formula:

$$(-n) \times (m) = (256 - n) \times m = 256m + (-nm)$$

The condition codes are nonetheless set according to the result.

Entry: Multiplicand in A, multiplier in B

Exit: Product in A, B

Condition

Codes: H = undefined
 N = bit 15 of product
 V = 0
 Z = 1 if product is zero;
 otherwise = D
 C = 0

Registers Altered: A, B, CC

Appendix Q

Data from the Optical Shaft Encoder and Ultrasonic Sonar subsystems are gathered every 0.1 second via the Extended Interrupt Handler (see Appendix B) and stored into a temporary line buffer in the Navigation Computer's memory as follows:

```
/time/fw/lw1/lw2/rw1/rw2/A#____/B#____/C#____/D#____/<CR><LF>
```

Where time = tenth's of seconds count - 2 bytes

fw = front wheel direction - 1 byte

lw1 = left wheel reverse counts - 2 bytes

lw2 = left wheel forward counts - 2 bytes

rw1 = right wheel reverse counts - 2 bytes

rw2 = right wheel forward counts - 2 bytes

A, B, C, or D refer to Sonar transducer selected and range of closest object except where an astrisk (*) indicates no transducer selected.

All numbers are hexadecimal except the sonar ranges which are decimal feet.

Test Data for Robot Integrated Operation Test # 20

```
/0001/49/0000/0000/0000/0001/A2 7.2/B*15.1/C0 2.5/D1 9.4/  
/0002/49/0000/0000/0000/0001/A019.3/B1 4.7/C2 3.9/D*10.7/  
/0003/49/0000/0000/0000/0001/A111.2/E2 2.9/C*11.3/D0 7.1/  
/0004/49/0000/0000/0000/0001/A2 7.4/B*13.7/C0 2.4/D1 8.4/  
/0005/49/0000/0000/0000/0001/A*12.6/B0 6.1/C1 3.0/D2 9.9/
```

/0006/49/0000/0000/0000/0001/A411.6/B5 3.5/C6 6.9/D*10.2/
/0007/49/0000/0000/0000/0001/A5 8.2/B6 2.6/C*11.9/D4 7.3/
/0008/49/0000/0000/0000/0001/A6 6.2/B*14.7/C4 2.7/D5 9.0/
/0009/49/0000/0000/0000/0001/A*17.8/B4 6.4/C5 3.5/D610.0/
/000A/49/0000/0000/0000/0001/A014.2/B1 4.9/C2 3.8/D*10.1/
/000B/49/0000/0000/0000/0001/A111.2/B2 2.9/C*11.3/D0 7.0/
/000C/47/0000/0000/0000/0001/A2 7.2/B*14.9/C0 2.5/D1 7.4/
/000D/47/0000/0000/0000/0001/A*12.9/B0 6.2/C1 3.0/D210.2/
/000E/48/0000/0000/0000/0001/A411.7/B5 3.4/C6 7.0/D* 9.9/
/000F/48/0000/0000/0000/0001/A5 8.1/B6 2.7/C*14.3/D4 7.3/
/0010/48/0000/0000/0000/0001/A6 6.3/B*13.1/C4 2.8/D5 9.1/
/0011/48/0000/0000/0000/0001/A*17.5/B4 6.4/C5 3.4/D611.2/
/0012/48/0000/0000/0000/0002/A013.1/B1 4.8/C2 3.8/D*10.1/
/0013/48/0000/0000/0000/0002/A111.2/B2 3.0/C*11.3/D0 7.1/
/0014/48/0000/0001/0000/0002/A2 7.3/B*14.8/C0 2.5/D1 7.3/
/0015/48/0000/0001/0000/0003/A*14.8/B0 6.1/C1 3.1/D2 8.5/
/0016/48/0000/0002/0000/0003/A411.6/B5 3.6/C6 7.3/D* 8.2/
/0017/48/0000/0003/0000/0004/A5 8.2/B6 2.9/C*14.7/D4 7.2/
/0018/47/0000/0004/0000/0005/A6 6.4/B*12.2/C4 2.9/D5 9.1/
/0019/47/0000/0005/0000/0006/A*17.4/B4 6.4/C5 3.8/D610.4/
/001A/47/0000/0006/0000/0008/A013.4/B1 5.7/C2 5.3/D*10.2/
/001B/47/0000/0007/0000/0009/A110.7/B2 3.4/C*11.4/D0 7.0/
/001C/47/0000/0009/0000/000A/A2 7.3/B*13.0/C0 3.2/D1 7.4/
/001D/47/0000/000A/0001/000B/A*15.5/B0 6.2/C1 3.6/D2 8.5/
/001E/47/0000/000B/0001/000D/A414.5/B5 4.6/C6 6.8/D*10.0/
/001F/47/0000/000D/0001/000E/A5 8.8/B6 3.7/C*14.1/D4 7.3/
/0020/47/0000/000E/0001/000F/A6 6.3/B*11.5/C4 3.6/D510.2/
/0021/46/0000/000F/0001/0011/A*14.7/B4 6.5/C5 4.8/D611.2/
/0022/46/0000/0011/0001/0012/A012.8/B1 6.8/C2 6.6/D*10.1/
/0023/46/0000/0012/0001/0013/A110.1/B2 4.4/C*10.1/D0 7.1/
/0024/46/0000/0013/0001/0015/A2 7.1/B*12.9/C0 4.0/D1 7.3/
/0025/46/0000/0015/0001/0016/A*12.8/B0 6.2/C1 4.7/D2 8.1/
/0026/46/0000/0016/0001/0017/A414.7/B5 5.7/C6 7.1/D* 9.9/
/0027/46/0000/0017/0001/0019/A5 9.6/B6 4.6/C*14.5/D4 7.3/
/0028/46/0000/0018/0001/001A/A6 6.4/B*14.6/C4 4.7/D510.1/
/0029/46/0000/001A/0001/001B/A*17.6/B4 6.3/C5 6.3/D610.7/
/002A/45/0000/001B/0002/001C/A011.1/B1 6.9/C2 7.1/D* 9.0/
/002B/45/0000/001C/0002/001E/A112.9/B2 5.4/C*11.6/D0 7.1/
/002C/45/0000/001E/0002/001F/A2 6.8/B*14.0/C0 5.0/D1 7.5/
/002D/45/0000/001F/0002/0020/A*17.1/B0 6.2/C1 5.5/D210.0/
/002E/45/0000/0020/0002/0022/A417.5/B5 6.8/C6 7.0/D* 9.9/
/002F/44/0000/0022/0002/0023/A5 6.9/B6 5.5/C*14.4/D4 7.4/
/0030/44/0000/0023/0002/0024/A6 6.4/B*14.5/C4 5.5/D5 9.5/
/0031/44/0000/0024/0002/0025/A*15.1/B4 6.5/C5 7.2/D611.4/
/0032/44/0000/0025/0002/0027/A014.9/B1 7.1/C2 6.6/D*10.0/
/0033/44/0000/0027/0002/0028/A111.8/B2 6.2/C*11.8/D0 7.1/
/0034/44/0000/0028/0003/0029/A2 6.8/B*13.0/C0 5.8/D1 7.5/
/0035/44/0000/0029/0003/002B/A*12.8/B0 6.2/C1 6.3/D210.2/
/0036/43/0000/002A/0003/002C/A416.6/B5 7.9/C6 7.0/D* 9.8/
/0037/43/0000/002C/0003/002D/A5 8.3/B6 6.3/C*14.0/D4 7.3/
/0038/43/0000/002D/0003/002E/A6 6.4/B*12.3/C4 6.6/D5 9.1/
/0039/43/0000/002E/0003/0030/A*18.0/B4 6.6/C5 6.6/D6 9.8/

/003A/43/0000/0030/0003/0031/A010.3/B1 6.8/C2 6.9/D*10.3/
/003B/43/0000/0031/0003/0032/A111.5/B2 7.1/C*11.7/D0 7.1/
/003C/43/0000/0032/0003/0033/A216.9/B*13.0/C0 6.5/D1 8.8/
/003D/43/0000/0033/0003/0035/A*17.4/B0 6.3/C1 6.7/D2 8.5/
/003E/42/0000/0035/0004/0036/A4 9.6/B5 8.5/C6 7.3/D* 9.7/
/003F/42/0000/0036/0004/0037/A5 7.9/B6 7.2/C*14.3/D4 7.3/
/0040/42/0000/0037/0004/0038/A6 6.4/B*11.8/C4 7.0/D5 9.0/
/0041/42/0000/0038/0004/003A/A*17.9/B4 6.5/C5 7.9/D610.3/
/0042/42/0000/003A/0004/003B/A014.6/B1 7.2/C2 6.6/D*10.2/
/0043/42/0000/003B/0004/003C/A110.8/B2 7.9/C*13.3/D0 7.1/
/0044/42/0000/003C/0004/003E/A2 7.2/B*14.6/C0 6.6/D1 8.2/
/0045/41/0000/003D/0004/003F/A*18.0/B0 6.1/C1 6.7/D210.2/
/0046/41/0000/003F/0004/0040/A410.4/B5 9.6/C6 7.3/D*10.1/
/0047/41/0000/0040/0004/0041/A510.4/B6 8.0/C*14.8/D4 7.4/
/0048/41/0000/0041/0004/0043/A6 6.3/B*14.6/C4 8.1/D510.4/
/0049/41/0000/0042/0005/0044/A*17.6/B4 6.5/C5 6.9/D612.5/
/004A/41/0000/0044/0005/0045/A014.2/B1 7.3/C2 7.5/D*10.3/
/004B/41/0000/0045/0005/0046/A111.3/B2 8.7/C*11.3/D0 7.1/
/004C/41/0000/0046/0005/0048/A2 7.0/B*14.4/C0 6.7/D1 7.8/
/004D/40/0000/0047/0005/0049/A*17.4/B0 6.2/C1 6.7/D2 8.4/
/004E/40/0000/0049/0005/004A/A414.0/B5 8.1/C6 7.3/D*10.1/
/004F/40/0000/004A/0005/004B/A5 8.7/B6 8.7/C*14.5/D4 7.5/
/0050/40/0000/004B/0005/004D/A6 6.3/B* 9.9/C4 8.1/D5 9.8/
/0051/40/0000/004C/0005/004E/A*16.7/B4 6.3/C5 8.2/D611.5/
/0052/40/0000/004E/0005/004F/A0 9.8/B1 7.3/C2 7.3/D* 9.9/
/0053/40/0000/004F/0006/0051/A111.4/B2 8.8/C*12.6/D0 7.1/
/0054/40/0000/0050/0006/0052/A2 6.7/B*14.4/C0 6.8/D1 8.0/
/0055/40/0000/0052/0006/0053/A*17.4/B0 6.2/C1 6.6/D210.2/
/0056/40/0000/0053/0006/0054/A413.3/B5 8.5/C6 7.2/D*10.6/
/0057/3F/0000/0054/0006/0056/A5 9.0/B6 9.7/C*14.9/D4 7.4/
/0058/3F/0000/0055/0006/0057/A6 6.4/B*14.2/C4 8.1/D5 9.3/
/0059/3F/0000/0057/0006/0058/A*17.3/B4 6.5/C5 6.8/D611.9/
/005A/3F/0000/0058/0007/0059/A012.5/B1 9.9/C2 7.1/D*10.0/
/005B/3E/0000/0059/0007/005B/A111.4/B2 8.6/C*11.4/D0 7.3/
/005C/3E/0000/005A/0007/005C/A2 7.2/B*14.6/C0 6.7/D1 9.0/
/005D/3E/0000/005C/0007/005D/A*17.9/B0 6.2/C1 6.7/D2 9.7/
/005E/3D/0000/005D/0007/005E/A412.3/B5 9.1/C6 7.3/D* 9.8/
/005F/3D/0000/005E/0007/0060/A5 8.5/B6 8.4/C*13.5/D4 7.3/
/0060/3D/0000/005F/0007/0061/A6 6.1/B*14.6/C4 8.2/D5 9.5/
/0061/3D/0000/0061/0007/0062/A*17.9/B4 6.5/C5 6.6/D611.7/
/0062/3C/0000/0062/0007/0063/A011.6/B1 6.8/C2 6.8/D*10.4/
/0063/3C/0000/0063/0008/0065/A111.3/B2 9.7/C*13.3/D0 7.1/
/0064/3C/0000/0064/0008/0066/A2 7.2/B*14.7/C0 6.7/D1 8.6/
/0065/3C/0000/0066/0008/0067/A*12.8/B0 6.2/C1 6.9/D210.2/
/0066/3C/0000/0067/0008/0069/A411.7/B5 9.6/C6 7.5/D* 9.8/
/0067/3C/0000/0068/0008/006A/A5 7.9/B611.3/C*14.4/D4 7.4/
/0068/3C/0000/006A/0008/006B/A6 6.3/B*12.3/C4 8.2/D5 8.1/
/0069/3C/0000/006B/0008/006C/A*18.4/B4 6.5/C5 8.1/D611.2/
/006A/3C/0000/006C/0008/006E/A010.7/B1 7.1/C2 7.2/D*10.7/
/006B/3C/0000/006D/0008/006F/A110.6/B2 9.8/C*13.1/D0 7.1/
/006C/3C/0000/006F/0009/0070/A2 7.2/B*14.4/C0 6.7/D1 8.2/
/006D/3B/0000/0070/0009/0071/A*14.5/B0 5.8/C1 6.8/D210.9/

/006E/3B/0000/0071/0009/0073/A410.7/B510.7/C6 7.7/D*10.7/
/006F/3B/0000/0072/0009/0074/A512.4/B612.1/C*14.6/D4 7.4/
/0070/3B/0000/0074/0009/0075/A6 6.4/B*11.0/C4 8.1/D510.9/
/0071/3B/0000/0075/0009/0076/A*18.2/B4 6.6/C5 8.2/D610.3/
/0072/3B/0000/0076/0009/0078/A010.0/B1 7.5/C2 8.1/D*10.9/
/0073/3B/0000/0077/0009/0079/A110.0/B2 9.7/C*14.0/D0 7.2/
/0074/3B/0000/0079/0009/007A/A2 7.1/B*13.2/C0 6.7/D1 7.9/
/0075/3B/0000/007A/0009/007B/A*17.5/B0 6.1/C1 7.2/D210.2/
/0076/3A/0000/007B/0009/007D/A410.1/B5 8.0/C6 7.4/D*10.1/
/0077/3A/0000/007C/000A/007E/A5 9.7/B6 9.7/C*14.2/D4 7.5/
/0078/3A/0000/007E/000A/007F/A6 6.3/B*14.5/C4 8.3/D510.5/
/0079/3A/0000/007F/000A/0080/A*18.0/B4 6.2/C5 8.1/D6 9.6/
/007A/3A/0000/0080/000A/0082/A0 9.1/B1 7.3/C2 7.8/D* 9.3/
/007B/3A/0000/0081/000A/0083/A1 9.8/B2 9.7/C* 9.9/D0 7.3/
/007C/3A/0000/0082/000A/0084/A2 6.7/B*15.2/C0 6.7/D1 8.1/
/007D/3A/0000/0084/000A/0085/A*17.1/B0 6.1/C1 7.2/D210.3/
/007E/3A/0000/0085/000A/0086/A4 9.3/B5 8.4/C6 7.3/D*11.3/
/007F/3A/0000/0086/000A/0088/A5 8.7/B611.2/C*14.9/D4 7.5/
/0080/3A/0000/0087/000A/0089/A6 6.4/B*12.2/C4 8.2/D5 9.9/
/0081/3A/0000/0089/000B/008A/A*18.8/B4 6.2/C5 8.2/D6 8.7/
/0082/3A/0000/008A/000B/008B/A0 8.3/B1 9.1/C2 7.9/D* 9.6/
/0083/39/0000/008B/000B/008D/A110.1/B210.0/C*10.1/D0 7.4/
/0084/39/0000/008C/000B/008E/A2 5.9/B*14.7/C0 6.7/D1 9.1/
/0085/39/0000/008E/000B/008F/A*17.3/B0 6.1/C1 6.8/D2 8.5/
/0086/39/0000/008F/000B/0090/A4 8.6/B5 9.0/C6 7.3/D*10.5/
/0087/39/0000/0090/000B/0092/A5 8.4/B6 8.4/C*14.4/D4 7.6/
/0088/39/0000/0091/000B/0093/A6 6.2/B*15.4/C4 8.2/D5 9.5/
/0089/39/0000/0093/000B/0094/A*15.7/B4 6.5/C5 8.3/D6 8.0/
/008A/38/0000/0094/000C/0095/A0 7.5/B1 6.6/C2 7.7/D*11.3/
/008B/38/0000/0095/000C/0096/A1 8.5/B2 9.8/C*14.6/D0 7.4/
/008C/38/0000/0096/000C/0098/A2 7.2/B*15.0/C0 7.2/D1 9.2/
/008D/37/0000/0097/000C/0099/A*20.6/B0 6.1/C1 7.9/D2 8.4/
/008E/37/0000/0099/000C/009A/A4 7.8/B5 9.4/C6 7.5/D*11.3/
/008F/37/0000/009A/000C/009B/A5 7.8/B610.1/C*15.3/D4 7.7/
/0090/37/0000/009B/000C/009C/A6 6.1/B*16.0/C4 8.1/D510.2/
/0091/37/0000/009C/000C/009E/A*20.5/B4 6.4/C5 8.1/D6 7.0/
/0092/37/0000/009D/000C/009F/A0 6.7/B1 6.9/C2 7.0/D*11.3/
/0093/37/0000/009E/000D/00A0/A1 7.5/B210.3/C*14.4/D0 7.4/
/0094/37/0000/00A0/000D/00A1/A2 7.1/B*14.6/C0 7.1/D1 8.7/
/0095/37/0000/00A1/000D/00A2/A*17.9/B0 6.1/C1 7.4/D210.0/
/0096/37/0000/00A2/000D/00A3/A4 6.7/B5 9.0/C6 7.5/D*10.9/
/0097/37/0000/00A3/000D/00A5/A5 7.6/B614.5/C*14.5/D4 7.7/
/0098/37/0000/00A4/000D/00A6/A6 6.5/B*14.7/C4 8.2/D5 9.7/
/0099/37/0000/00A5/000E/00A7/A*19.6/B4 6.4/C5 8.2/D6 6.4/
/009A/37/0000/00A7/000E/00A8/A0 5.9/B1 7.3/C2 8.3/D*10.8/
/009B/37/0000/00A8/000E/00A9/A1 6.7/B210.2/C*14.4/D0 7.4/
/009C/37/0000/00A9/000E/00AA/A2 7.1/B*14.4/C0 6.7/D1 8.4/
/009D/37/0000/00AA/000E/00AC/A*16.9/B0 6.0/C1 6.7/D2 6.2/
/009E/37/0000/00AB/000E/00AD/A410.6/B5 7.8/C6 7.5/D*10.7/
/009F/37/0000/00AD/000E/00AE/A5 6.7/B610.0/C*15.6/D4 7.7/
/00A0/37/0000/00AE/000E/00AF/A6 6.5/B*15.5/C4 8.2/D5 9.4/
/00A1/37/0000/00AF/000E/00B0/A*20.5/B4 6.3/C5 8.3/D6 5.5/

/00A2/36/0000/00B0/000F/00B2/A0 5.2/B1 7.2/C2 8.5/D*11.7/
/00A3/36/0000/00B1/000F/00B3/A1 6.0/B210.1/C*14.6/D0 7.4/
/00A4/36/0000/00B2/000F/00B4/A2 6.7/B*15.3/C0 7.3/D1 8.2/
/00A5/36/0000/00B4/000F/00B5/A*17.2/B0 6.1/C1 7.8/D2 5.4/
/00A6/36/0000/00B5/000F/00B5/A4 5.0/B5 8.1/C6 7.6/D*11.3/
/00A7/36/0000/00B6/000F/00B8/A5 7.7/B614.5/C*14.6/D4 7.7/
/00A8/36/0000/00B7/000F/00B9/A6 6.3/B*14.5/C4 8.1/D5 9.1/
/00A9/36/0000/00B9/000F/00BA/A*20.7/B4 6.2/C5 8.5/D6 4.9/
/00AA/36/0000/00BA/000F/00BB/A0 4.3/B1 7.4/C2 8.2/D*10.2/
/00AB/36/0000/00BB/0010/00BD/A1 5.3/B2 9.0/C*14.8/D0 7.4/
/00AC/36/0000/00BC/0010/00BE/A2 6.4/B* 8.2/C0 8.1/D1 8.1/
/00AD/35/0000/00BE/0010/00BF/A*16.8/B0 6.0/C1 6.7/D2 4.7/
/00AE/35/0000/00BF/0010/00C0/A4 4.2/B5 8.7/C6 7.7/D*10.3/
/00AF/35/0000/00C0/0010/00C2/A5 7.4/B615.0/C*15.0/D4 7.6/
/00B0/35/0000/00C1/0010/00C3/A6 6.2/B*12.1/C4 8.5/D5 6.9/
/00B1/35/0000/00C3/0010/00C4/A*20.8/B4 6.3/C5 8.1/D6 7.6/
/00B2/34/0000/00C4/0010/00C6/A0 3.5/B1 6.6/C2 8.1/D*10.1/
/00B3/34/0000/00C5/0010/00C7/A1 5.0/B210.7/C*14.7/D0 7.5/
/00B4/34/0000/00C7/0010/00C8/A2 6.8/B*13.4/C0 7.6/D1 8.2/
/00B5/34/0000/00C8/0010/00C9/A*16.9/B0 6.1/C1 8.6/D2 8.2/
/00B6/33/0000/00C9/0010/00CB/A4 3.5/B5 9.4/C6 7.7/D*12.3/
/00B7/33/0000/00CA/0010/00CC/A5 4.2/B614.9/C*15.0/D4 7.8/
/00B8/33/0000/00CC/0011/00CD/A6 5.9/B*13.2/C410.0/D5 3.8/
/00B9/32/0000/00CD/0011/00CE/A*20.6/B4 6.3/C5 8.5/D6 5.4/
/00BA/32/0000/00CE/0011/00CF/A0 2.7/B1 6.9/C2 8.2/D* 9.0/
/00BB/32/0000/00CF/0011/00D1/A110.4/B210.0/C*13.5/D0 7.5/
/00BC/32/0000/00D0/0011/00D2/A2 6.5/B*15.1/C0 7.6/D1 7.9/
/00BD/31/0000/00D1/0011/00D3/A*17.6/B0 5.9/C1 8.2/D2 8.6/
/00BE/31/0000/00D2/0011/00D4/A412.1/B5 9.9/C6 7.9/D*10.1/
/00BF/31/0000/00D3/0011/00D4/A5 3.7/B615.0/C*15.0/D4 7.8/
/00C0/31/0000/00D3/0011/00D5/A6 6.4/B*12.5/C4 8.2/D5 3.3/
/00C1/31/0000/00D3/0011/00D5/A*18.0/B4 6.3/C5 8.4/D6 4.0/
/00C2/31/0000/00D4/0011/00D5/A0 2.1/B1 7.1/C2 8.2/D*11.7/
/00C3/31/0000/00D4/0011/00D5/A1 9.2/B2 9.1/C*14.5/D0 7.5/
/00C4/31/0000/00D4/0011/00D5/A2 6.4/B*13.2/C0 8.1/D1 8.1/
/00C5/31/0000/00D4/0011/00D5/A*20.0/B0 5.8/C1 8.1/D2 8.5/
/00C6/31/0000/00D4/0011/00D5/A4 2.3/B510.2/C6 7.8/D*11.5/
/00C7/31/0000/00D4/0011/00D5/A5 3.7/B614.4/C*14.4/D4 7.7/
/00C8/31/0000/00D4/0011/00D5/A6 6.2/B*12.6/C4 8.7/D5 3.4/
/00C9/31/0000/00D4/0011/00D5/A*18.3/B4 6.3/C5 9.3/D6 3.9/
/00CA/31/0000/00D4/0011/00D5/A0 2.2/B1 7.1/C2 8.5/D*11.5/
/00CB/31/0000/00D4/0011/00D5/A1 9.1/B2 9.0/C*14.5/D0 7.5/
/00CC/31/0000/00D4/0011/00D5/A2 6.5/B*13.0/C0 7.5/D1 8.1/
/00CD/31/0000/00D4/0011/00D5/A*17.5/B0 5.8/C1 8.2/D2 8.5/
/00CE/31/0000/00D4/0011/00D5/A4 2.4/B510.1/C6 7.8/D*10.1/
/00CF/31/0000/00D4/0011/00D5/A5 3.7/B617.8/C*14.5/D4 7.8/
/00D0/31/0000/00D4/0011/00D5/A6 6.3/B*14.1/C414.2/D5 3.3/
/00D1/31/0000/00D4/0011/00D5/A*20.6/B4 6.3/C5 9.7/D6 3.9/
/00D2/31/0000/00D4/0011/00D5/A0 2.1/B1 7.1/C2 8.4/D*14.8/
/00D3/31/0000/00D4/0011/00D5/A1 9.2/B2 9.1/C*14.8/D0 7.5/
/00D4/31/0000/00D4/0011/00D5/A2 6.4/B*14.8/C010.4/D1 8.2/
/00D5/31/0000/00D4/0011/00D5/A*19.9/B0 5.8/C111.3/D2 8.6/

/00D6/31/0000/00D4/0011/00D5/A4 2.3/B510.2/C6 7.8/D*14.8/
/00D7/31/0000/00D4/0011/00D5/A5 3.7/B618.0/C*18.1/D4 7.7/
/00D8/31/0000/00D4/0011/00D5/A6 6.2/B*14.1/C414.1/D5 3.4/
/00D9/31/0000/00D4/0011/00D5/A*20.5/B4 6.3/C5 9.6/D6 3.9/
/00DA/31/0000/00D4/0011/00D5/A0 2.2/B1 7.1/C2 8.5/D*14.9/
/00DB/31/0000/00D4/0011/00D5/A1 9.1/B2 9.1/C*14.7/D0 7.5/
/00DC/31/0000/00D4/0011/00D5/A2 6.5/B*14.8/C0 8.2/D1 6.1/
/00DD/31/0000/00D4/0011/00D5/A*19.8/B0 5.8/C111.3/D2 8.6/
/00DE/31/0000/00D4/0011/00D5/A4 2.3/B510.1/C6 7.9/D*14.7/
/00DF/31/0000/00D4/0011/00D5/A5 3.7/B615.1/C*15.0/D4 7.8/
/00E0/31/0000/00D4/0011/00D5/A6 6.2/B*14.1/C414.0/D5 3.3/
/00E1/31/0000/00D4/0011/00D5/A*20.6/B4 6.3/C5 9.7/D6 3.9/
/00E2/31/0000/00D4/0011/00D5/A0 2.1/B1 7.1/C2 8.3/D*13.0/
/00E3/31/0000/00D4/0011/00D5/A1 9.2/B2 9.0/C*14.8/D0 7.6/
/00E4/31/0000/00D4/0011/00D5/A2 6.4/B*17.8/C0 8.1/D1 8.1/

REPORT DOCUMENTATION PAGE

1a. REPORT SECURITY CLASSIFICATION UNCLASSIFIED		1b. RESTRICTIVE MARKINGS	
2a. SECURITY CLASSIFICATION AUTHORITY		3. DISTRIBUTION/AVAILABILITY OF REPORT UNLIMITED	
2b. DECLASSIFICATION/DOWNGRADING SCHEDULE			
4. PERFORMING ORGANIZATION REPORT NUMBER(S) AFIT/GE/ENG/84D-19		5. MONITORING ORGANIZATION REPORT NUMBER(S)	
6a. NAME OF PERFORMING ORGANIZATION School of Engineering	6b. OFFICE SYMBOL (If applicable) AFIT/ENG	7a. NAME OF MONITORING ORGANIZATION	
6c. ADDRESS (City, State and ZIP Code) Air Force Institute of Technology Wright-Patterson AFB, Ohio 45433		7b. ADDRESS (City, State and ZIP Code)	
8a. NAME OF FUNDING/SPONSORING ORGANIZATION	8b. OFFICE SYMBOL (If applicable)	9. PROCUREMENT INSTRUMENT IDENTIFICATION NUMBER	
8c. ADDRESS (City, State and ZIP Code)		10. SOURCE OF FUNDING NOS.	
		PROGRAM ELEMENT NO.	PROJECT NO.
		TASK NO.	WORK UNIT NO.
11. TITLE (Include Security Classification) Creating a Mobile Autonomous Robot Research System (MARRS)			
12. PERSONAL AUTHOR(S) Thomas E. Clifford, 1st Lt, USAF Hubert G. Schneider III, Capt, USAF			
13a. TYPE OF REPORT MS Thesis	13b. TIME COVERED FROM _____ TO _____	14. DATE OF REPORT (Yr., Mo., Day) 1984 December	15. PAGE COUNT 256
16. SUPPLEMENTARY NOTATION <i>Approved for public release; LAW AFB 19C-17.</i> <i>Ltjrn E. WOLAVER 28 Feb 85</i> Dean for Research and Professional Development Air Force Institute of Technology (AFIT)			
17. COSATI CODES		18. SUBJECT TERMS (Continue on reverse if necessary and identify by block number)	
FIELD	GROUP	SUB. GR.	Autonomous Vehicle, Robot, Environmental Mapping, Basic, Sonar, Shaft Encoder, Ultrasonics, Navigation, Micro-processors, <i>Computer Programs, Thesis</i>
19. ABSTRACT (Continue on reverse if necessary and identify by block number) The Mobile Autonomous Robot Research System (MARRS-1) was created as the first of a series of autonomous vehicle prototypes for the Air Force Institute of Technology. The major accomplishment in developing MARRS-1 is the integration of Optical Shaft Encoder (OSE) data with Ultrasonic Sonar range and direction information to produce accurate environmental maps that are relative to the robot. The OSE and Sonar subsystems make up the most important part of MARRS-1's Navigation Computer. With these two subsystems and minimal additional software, mapping and obstacle avoidance become a reality. The thesis includes schematics, parts list, and software listings for the MARRS-1 Navigation Computer. Additionally, the mapping and navigation algorithms are shown implemented in the BASIC language with numerous example graphics maps created by the integrated MARRS-1 robot. Issues involved in solving mobile robotics problems are discussed.			
20. DISTRIBUTION/AVAILABILITY OF ABSTRACT UNCLASSIFIED/UNLIMITED <input checked="" type="checkbox"/> SAME AS RPT. <input type="checkbox"/> DTIC USERS <input type="checkbox"/>		21. ABSTRACT SECURITY CLASSIFICATION UNCLASSIFIED	
22a. NAME OF RESPONSIBLE INDIVIDUAL Dr. Matthew Kabrisky		22b. TELEPHONE NUMBER (Include Area Code) 513-255-5276	22c. OFFICE SYMBOL AFIT/ENG