

**B
R
L**

AD A152298

MEMORANDUM REPORT BRL-MR-3427

**DETONATION VELOCITY MEASUREMENTS OF THE
EXPLOSIVES DETASHEET C AND AMATOL**

Paul H. Netherwood, Jr.

January 1985

APPROVED FOR PUBLIC RELEASE; DISTRIBUTION UNLIMITED.

**US ARMY BALLISTIC RESEARCH LABORATORY
ABERDEEN PROVING GROUND, MARYLAND**

Destroy this report when it is no longer needed.
Do not return it to the originator.

Additional copies of this report may be obtained
from the National Technical Information Service,
U. S. Department of Commerce, Springfield, Virginia
22161.

The findings in this report are not to be construed as an official
Department of the Army position, unless so designated by other
authorized documents.

The use of trade names or manufacturers' names in this report
does not constitute indorsement of any commercial product.

TABLE OF CONTENTS

	Page
LIST OF ILLUSTRATIONS	5
LIST OF TABLES	7
I. INTRODUCTION	9
II. PROCEDURE	11
III. RESULTS	14
IV. CONCLUSIONS	19
ACKNOWLEDGEMENTS	20
REFERENCES	21
DISTRIBUTION LIST	23

LIST OF ILLUSTRATIONS

Figure	Page
1. Schematic Drawing of Resistance-Wire Detonation Velocity Gage . . .	11
2. Battery Powered Constant-Current Gage Power Supply	13
3. AC Powered Constant-Current Gage Power Supply	13
4. Gage Signal for Detasheet C. Oscilloscope bandwidth 150 megahertz, battery powered constant-current power supply, and silver print ground contact.	15
5. Gage Signal for Detasheet C. Oscilloscope bandwidth 100 kilohertz, battery powered constant-current power supply, and silver print ground contact.	15
6. Gage Signal for Detasheet C. Oscilloscope bandwidth 100 kilohertz, AC powered constant-current power supply, soldered ground contact .	16
7. Schematic Drawing of Plexiglas Container Used for Detonation Measurements of Powdered Explosives	16

LIST OF TABLES

Table	Page
1. Properties of Explosives10
2. Detonation Velocity Tests - 15.9 mm Detasheet C17
3. Detonation Velocity Tests - 80-20 Amatol18

I. INTRODUCTION

Explosive compaction of powdered materials shows great promise as a way to produce new materials with unique properties and to fabricate current materials more economically.

The explosive must be carefully matched to the material, particle size, initial density, and geometry of the compaction specimen. The two most critical factors are the detonation pressure of the explosive, which determines the intensity of the shock wave delivered to the powder, and the charge weight, which determines the duration of the shock loading and total energy input. An explosive with too low a peak pressure will not compact the specimen; and an explosive with too high a peak pressure can cause cracking, melting, and voids in the specimen. Full density cast or pressed military explosives have proven to be too powerful. The explosives that have worked the best for powder compaction are those whose densities have been reduced (powdered explosives) and those whose chemical compositions limit their peak pressures (blasting explosives, slurry explosives).

We planned to compact materials with a wide range of properties, and it was clear that one explosive would not be able to perform all the tasks. A group of explosives was ordered whose detonation velocities and detonation pressures covered a wide range. Table 1 shows handbook values¹⁻⁵ for the behaviors of these explosives.

The detonation properties of the explosives vary with loading density, and in many cases, with charge thickness. This provides an opportunity to make adjustments in the shock loading, but also provides a potential source of unplanned variation in explosive performance. We concluded that it would be prudent to monitor the explosive performance on all tests. A technique which could be used on field firings was necessary, and it was desirable that the technique show run-up or run-down detonation behavior after initiation so that charge length could be optimized.

¹B. M. Dobratz, "LLNL Explosives Handbook: Properties of Chemical Explosives and Explosive Simulants," Lawrence Livermore National Laboratory Report No. UCRL-52997, March 1981.

²L. Perm, F. Helm, M. Finger, and E. Lee, "Determination of Equation of State Parameters for Four Types of Explosives," Lawrence Livermore Laboratory Report No. UCRL-51829, August 1975.

³B. Crossland and J. A. Cave, Proceedings, 5th International Conference on High Energy Rate Fabrication, University of Denver Research Institute, Colorado, 1975, pp. 4.9.0-4.9.11.

⁴M. A. Cook, E. B. Mayfield, and W. S. Partridge, "Reaction Rates of Ammonium Nitrate in Detonation," Journal of Physical Chemistry, 59, 1955, pp. 675-680.

⁵H. C. Hoenig, E. L. Lee, M. Finger, and J. E. Kurrle, "Equation of State of Detonation Products," Proceedings, 5th Symposium (International) on Detonation, S. J. Jacobs and R. Roberts, Eds., Superintendent of Documents, Washington, DC, 1970, pp. 503-512.

Table 1. Properties of Explosives

TYPE	COMPOSITION	SOURCE	DENSITY	THICKNESS OR	DETONATION	C-J PRESSURE*
			g/cc	DIAMETER	VELOCITY	Gigapascals
				mm	mm/μsec	
AMATOL	80% Ammonium Nitrate 20% TNT	CIL	1.02	N/A	3.65	3.4
ANFO	94% Ammonium Nitrate 6% Fuel Oil	duPont	0.82	30.0 406.0	1.6 5.3	0.54 5.97
ANFO	88% Ammonium Nitrate 12% Fuel Oil	Laboratory Mixture	0.9	30.0 40.0 79.0 86.0	1.25 1.55 2.05 2.10	0.35 0.54 0.79 0.99
AN-TNT	50% Ammonium Nitrate 50% TNT	Laboratory Mixture	1.0	13.0 25.0 50.0 246.0	1.82 2.99 3.79 4.71	0.83 2.24 3.59 5.50
SWP-9	Ammonium Nitrate Waxed PETN	Trojan	1.04	12.7 31.8	1.68 2.44	0.73 1.55
DBA-10HV	Ammonium Nitrate Sodium Nitrate	IRECO	1.25	N/A	3.38	3.57
PETN	PETN Super Fine	duPont	0.25 0.48 0.99 1.53 1.76	44.5 38.1 25.4 25.4 50.8	2.83 3.60 5.48 7.49 8.28	0.7** 2.4 8.7 22.5 33.8

10

$$* P_{CJ} = \frac{\rho D^2}{\gamma + 1}, \gamma = 3$$

** P_{CJ} values from Reference 5

The objectives of the explosives characterization program were to measure the parameters required for a complete description of the explosives input to each test: detonation velocity, Chapman-Jouguet pressure, and pulse duration. The work to date has concentrated on the most accessible of these, the explosive detonation velocity.

II. PROCEDURE

The gage which was selected is the co-axial resistance-wire gage.⁶ The gage, as shown in Figure 1, consists of an 0.076-mm diameter resistance wire inside a thin wall 0.584-mm OD, 0.508-mm ID aluminum tube.** The wire is insulated from the tube by skip-wound nylon thread. This insulation prevents the wire from contacting the tube under normal conditions but leaves a spiral gap which allows contact between wire and tube when the tube is crushed by the detonation front of the explosive.

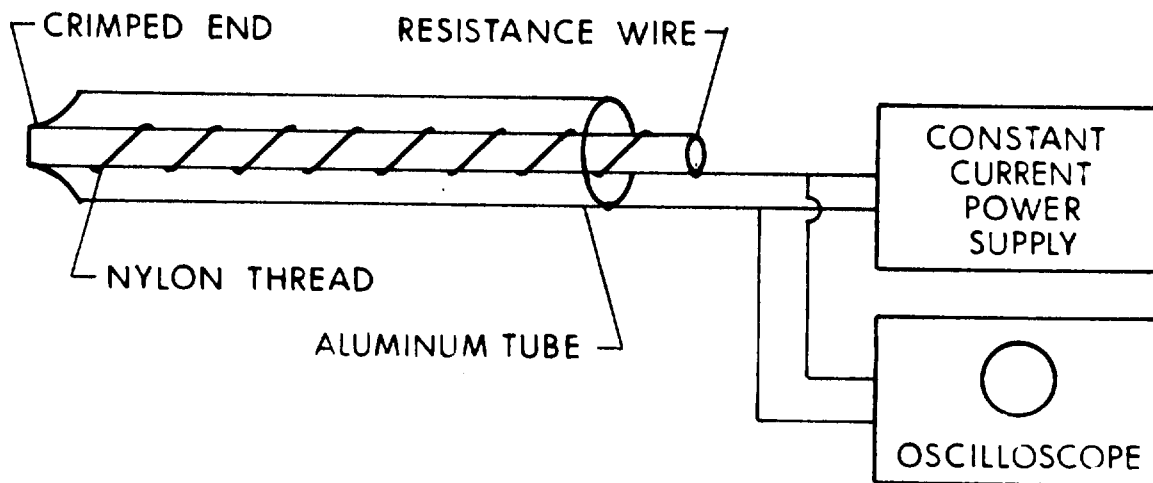

Figure 1. Schematic Drawing of Resistance-Wire Detonation Velocity Gage.

⁶J. Ribovich, R. W. Watson, and F. C. Gibson, "Instrumented Card-Gap Test," *AIAA Journal*, 6, 1968, pp. 1260-1263.

*"Moleculoy," 75NI, 20CR, 3AL, 2CO, Moleculowire Corp., Farmingdale, NJ.

**Precision Tube Co., Inc., North Wales, PA.

The gages were assembled by running a length of the Moleculoy wire through the aluminum tube so that 20 mm of the wire extended from one end of the tube. Approximately 5 mm of the tube was flattened, holding the wire in place. Insulation was stripped from the wire, and it was cut to 5 mm in length. The wire was then bent back against the flattened part of the aluminum tube, which was then folded and crimped over the wire. The joint was painted with conducting silver print.

A contact was made to the other end of the tube by folding a piece of 0.0254 mm brass foil around the aluminum tube, filling the joint with conducting silver print, and clamping the foil with a screw. The contact to the resistance wire was made by clamping the wire between two washers. The cable-gage connections were made inside an aluminum mini-box, to shield against noise pick-up.

The silver print/brass foil ground contact was later found to be unreliable, introducing a variable resistance into the circuit. An improved contact was achieved by soldering a fine copper wire directly to the aluminum tube, using lead-tin solder and LACO #3 Aluminum Flux.*** The aluminum tube was gently scraped clean with a razor blade, fluxed, and heated rapidly with a soldering iron. Excess flux was removed by ultrasonic cleaning in ethanol.

The gage is driven by a constant-current power supply. With a constant current in the gage circuit, the voltage seen on the oscilloscope is directly proportional to the gage resistance and, therefore, to gage length.

The simplest constant-current supply consists of a battery with a large resistor in series with the gage. If the series resistor is sufficiently large, the change in current resulting from the change in gage resistance is small. Figure 2 shows the circuit used for the first tests. The series resistor R_1 is $100K\Omega$, and the gage initial resistance is nominally 100Ω . When the gage resistance decreases, the change in current is $\sim 0.1\%$ and can be neglected. The basic series circuit was modified by the addition of two $100K\Omega$ resistors (R_2) in parallel with the gage. These resistors limit the input voltage to the oscilloscope to 100V in the event that the gage circuit opens.

The battery supply has one major advantage in addition to simplicity. It has no connections to an AC supply and therefore is less vulnerable to noise transmitted over power lines.

The battery supply was used for several tests, then was modified by paralleling a second $100k\Omega$ resistor with the series resistor to double the current to 6 milliamperes. Further tests showed the gage current and signal voltage to be too small for consistent results. Increased current from a battery supply proved impractical, requiring a high-power series resistor and many batteries.

The gage power supply was changed to a derivative of the circuit described by Ribovich, et al (see Figure 3). Parts substitutions were made to enable use of components on hand, and an AC modular power supply was substituted for a battery supply when batteries proved unable to handle the load.

***Lake Chemical Company, Chicago, IL.

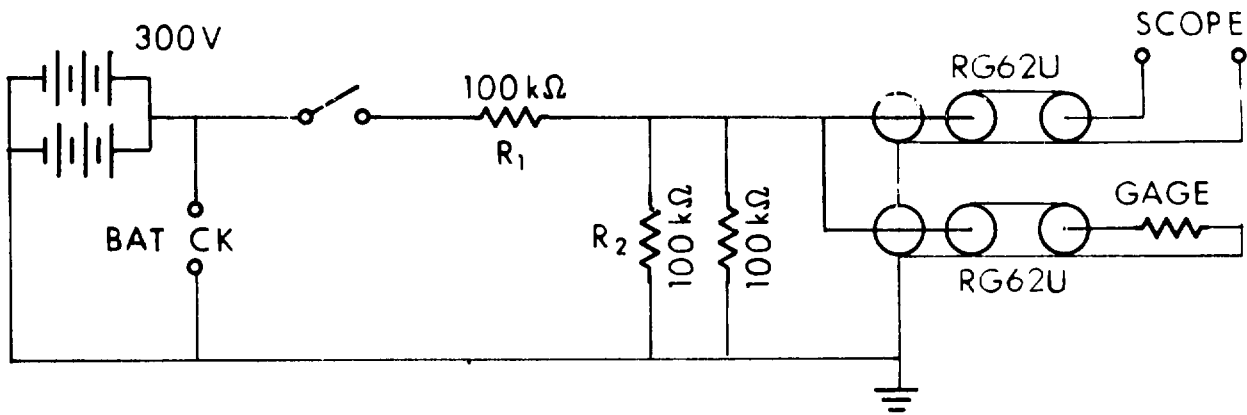

Figure 2. Battery Powered Constant-Current Gage Power Supply.

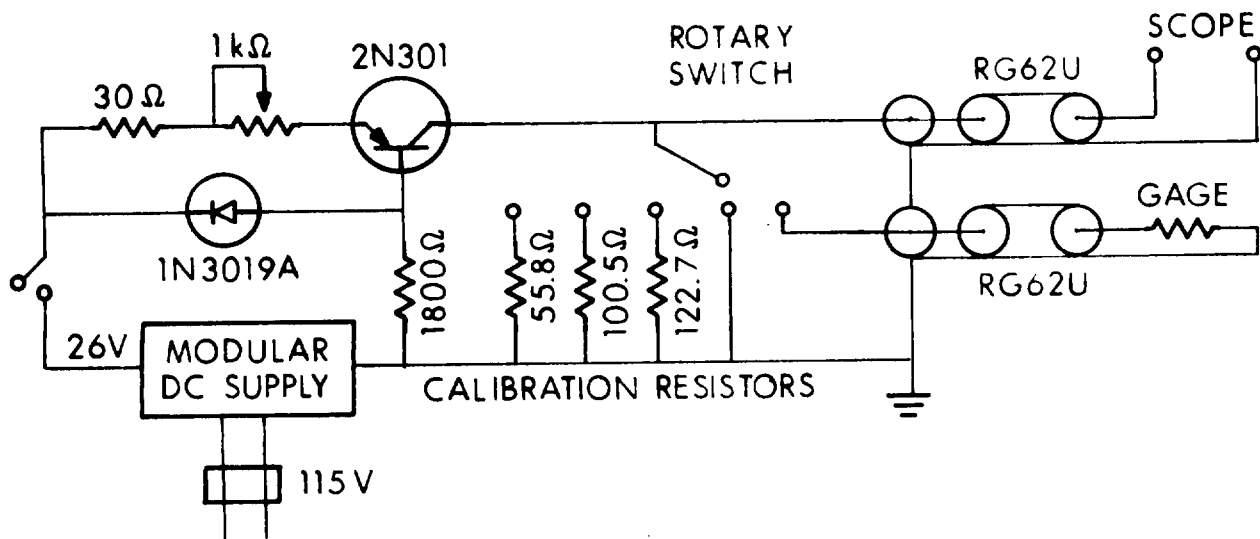

Figure 3. AC Powered Constant-Current Gage Power Supply.

The co-axial design of the gage helps to reduce electrical noise pick-up but does not completely eliminate problems. One of the compaction experiment designs planned required simultaneous initiation of two explosive charges. Exploding bridge-wire detonators provide the most accurate timing of initiation; however, they require a high-voltage firing unit, a frequent cause of noise pick-up. Since it was expected that this firing unit would be required for monitored compaction tests, it was concluded that it would be best to use the high voltage unit on the initial tests and to develop shielding and filtering techniques to reduce noise.

The high-voltage firing unit produced a high-frequency ringing pulse superimposed on the signals. This noise was reduced by the use of a Tektronix type 1A7 preamplifier in the oscilloscope. The 1A7 has a variable band pass, and it was set to eliminate frequencies above 100kHz. This filtered out the high-frequency noise very well on tests using the battery-powered gage supply. When the change was made to an AC powered gage supply, the noise problem recurred. The final tests were fired using low-voltage detonators and a battery-powered firing supply; clean signals were again recorded. Figures 4 - 6 show the changes in recorded signals as the gage, power supply, and recording instruments were changed.

Two explosives were studied during the technique development period. Detasheet C was used for several tests because it is convenient to use and the design and construction of the experiments could be simplified. The Detasheet C charges were tested on supports of 63.5 mm thick plexiglas. The detonation velocity gage was epoxied to the plexiglas, and a strip of 1.59 mm thick Detasheet was epoxied over the gage.

The explosive used for the remaining tests was powdered 80-20 Amatol, which had been passed through a #40 mesh screen. The Amatol powder was fired as rectangular slab charges contained in plexiglas boxes (see Figure 7). Accurately machined spacing bars made from 12.7 mm plexiglas formed the ends and bottom of the box, while sheets of 3.17 mm or 6.35 mm plexiglas were used for the front and back sides. Charge thickness was varied by changing the height of the spacing bars. Initiation was by a linewave generator that entered the box through a machined slot, and a layer of Detasheet covering the end of the box acted as a booster charge. The detonation velocity gage was epoxied to the inside of the box, along the centerline of one side.

III. RESULTS

Detonation velocities were measured for two explosives, Detasheet C and 80-20 Amatol, one of the explosives used for powder compaction work. Tables 2 and 3 summarize the results, showing primarily the changes that occurred as the technique was refined. The early tests using the battery gage supply (gage current = 3 mA) and/or silver print ground connections produced signals with apparent changes in velocity (wander) and also erratic average velocities. After the gage current was increased to 50 mA with the AC powered supply and soldered ground connections were used, clean signals with reproducible velocities were achieved. All tests with the low-current supply and silver print grounds must be regarded as suspect.

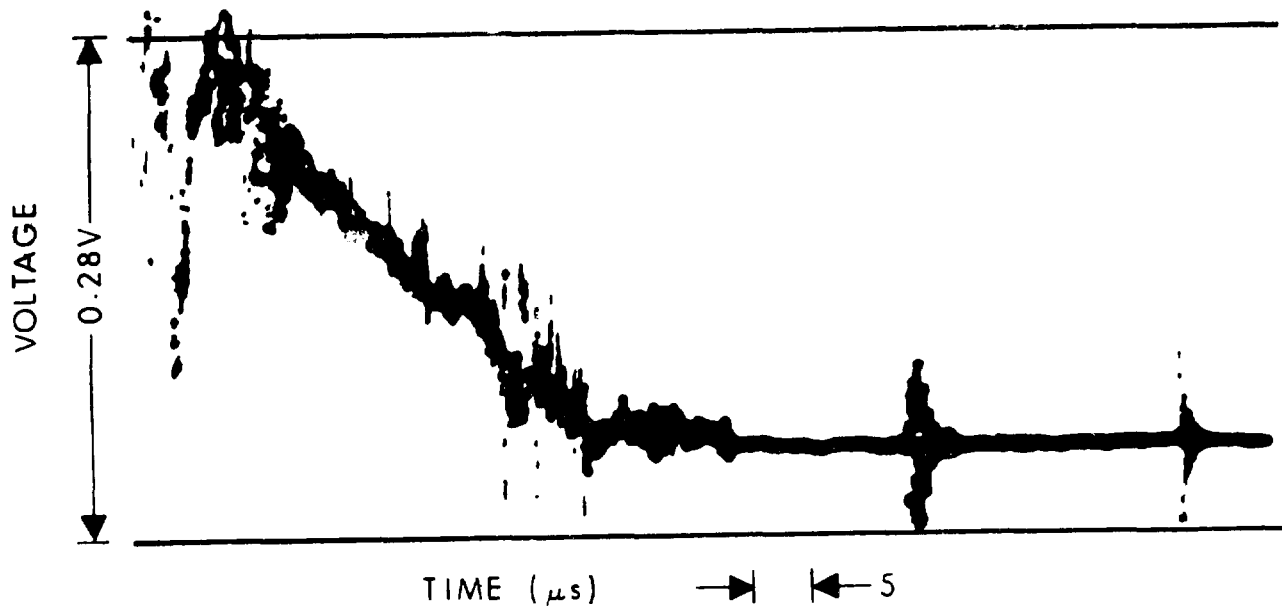

Figure 4. Gage Signal for Detasheet C. Oscilloscope bandwidth 150 megahertz, battery powered constant-current power supply, and silver print ground contact.

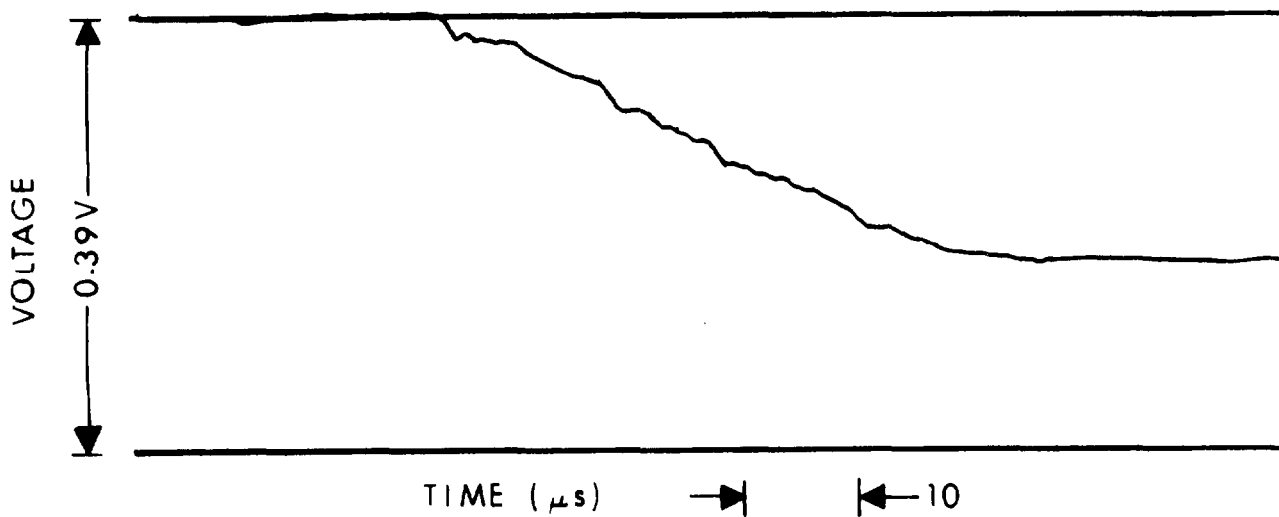

Figure 5. Gage Signal for Detasheet C. Oscilloscope bandwidth 100 kilohertz, battery powered constant-current power supply, and silver print ground contact.

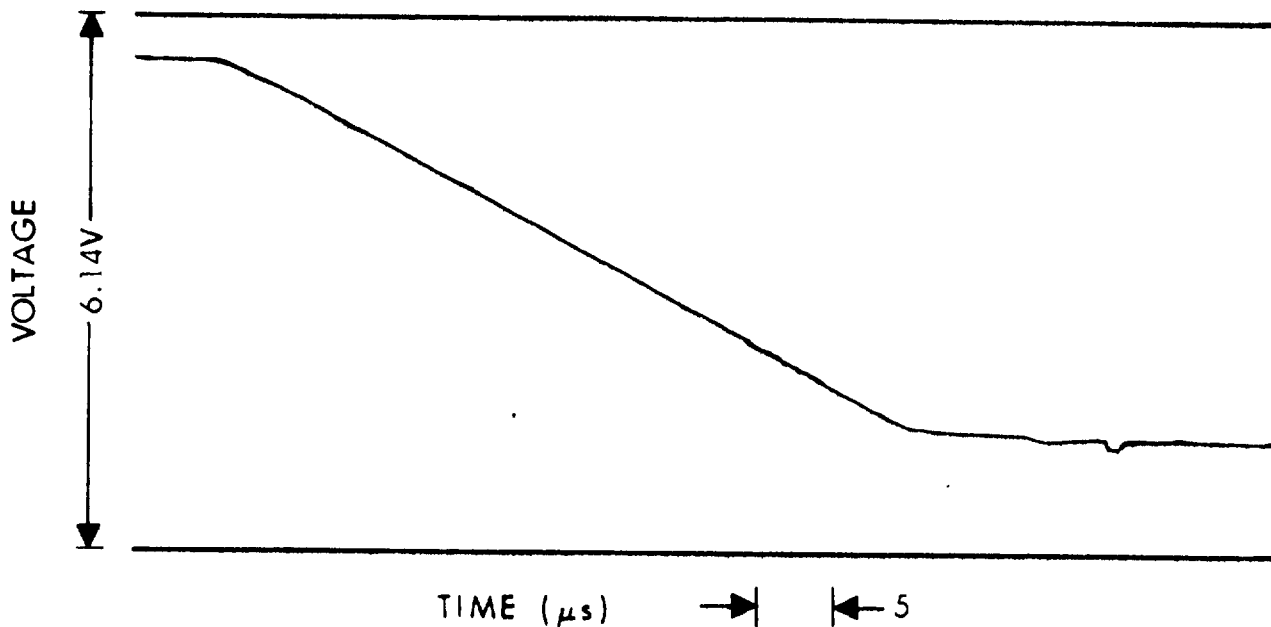

Figure 6. Gage Signal for Detasheet C. Oscilloscope bandwidth 100 kilohertz, AC powered constant-current power supply, soldered ground contact.

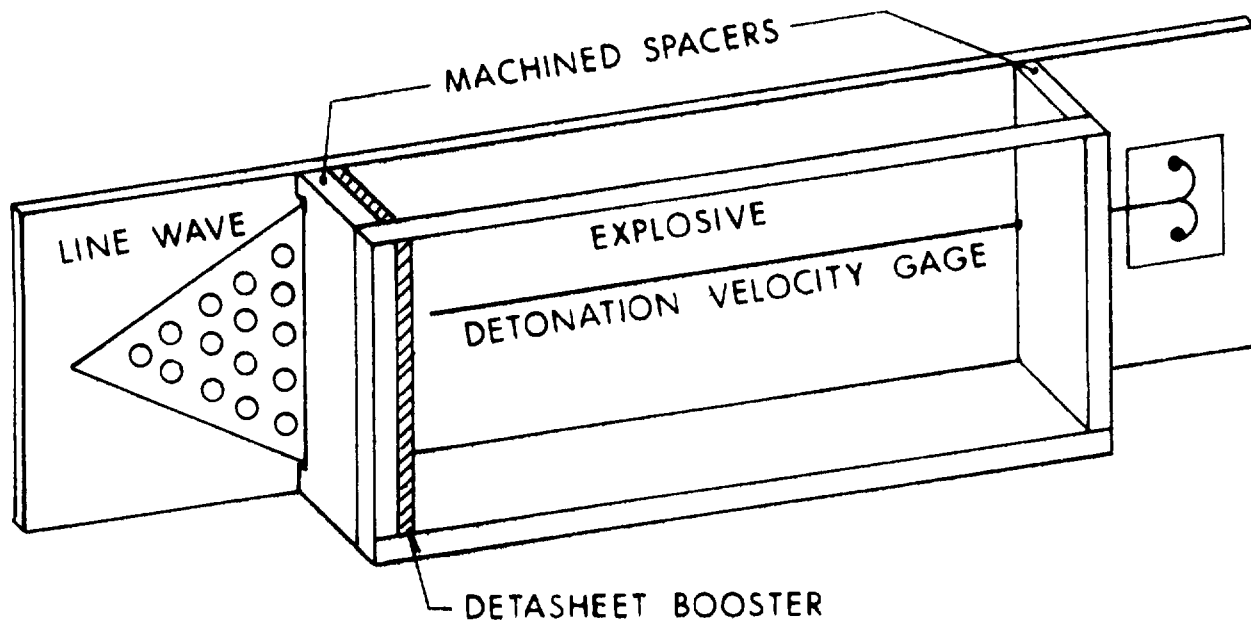

Figure 7. Schematic Drawing of Plexiglas Container Used for Detonation Measurements of Powered Explosives.

Table 2.

Detonation Velocity Tests - 15.9 mm Detasheet C

TEST	GAGE SUPPLY	GAGE GROUND	DETONATION VELOCITY mm/ μ sec	COMMENTS
1	DC ^a	P ^c	7.8	noisy
2	DC	P	5.9	noisy
3	DC	P	5.4	wanders
4	DC	P	6.4	wanders
9	AC ^b	S ^d	6.91	
10	AC	S	6.95	

^abattery supply, I = 3 mA

^bAC supply, I = 50 mA

^cP = silver print

^dS = soldered

Table 3. Detonation Velocity Tests - 80-20 Amatol

TEST	EXPLOSIVE THICKNESS mm	EXPLOSIVE DENSITY g/cc	GAGE SUPPLY	GAGE GROUND	DETONATION VELOCITY mm/ μ sec	CONFINEMENT PLEXIGLAS mm	COMMENTS
5	12.7	-	DC ^a	P ^c	3.32	3.17	wanders
6	25.4	-	DC	P	3.69	3.17	wanders
8	25.4	0.98	AC ^b	P	3.70	3.17	rings
13	6.4	0.91	AC	S ^d	2.32	6.35	
15	19.1	0.96	AC	S	3.78	6.35	
16	20.0	0.92	AC	S	3.86	6.35	
17	20.0	0.95	AC	S	3.86	6.35	

^abattery supply, I = 3 mA

^bAC supply, I = 50 mA

^cP = silver print

^dS = soldered

The nominal detonation velocity for Detasheet C is 6.8 mm/ μ sec, while Wells⁷ measured detonation velocities from 6.94 to 7.03 mm/ μ sec for three lots of EL506C sheet explosive. (EL506C is an older designation for Detasheet C.) The measured values for tests 9 and 10 of 6.91 and 6.95 mm/ μ sec are 2% above the nominal value, within the variation to be expected from manufacturing tolerances and experimental error.

The detonation velocity of a powdered explosive is a function of charge density, particle size, charge thickness (or diameter), and confinement. The manufacturers value for the detonation velocity of 80-20 Amatol at a density of 1.02 g/cc is $V = 3.65$ mm/ μ sec with thickness and confinement unspecified. The velocities reported here are slightly higher, 3.78-3.86 mm/ μ sec for 19.1-20 mm thick charges at densities of 0.92-0.96 kg/cc. The single test at a charge thickness of 6.35 mm is close to the lower limit for detonation propagation, with a measured velocity of 2.32 mm/ μ sec. More tests are required to verify the velocity-thickness relationship in this range.

IV. CONCLUSIONS

The techniques required to use resistance-wire detonation velocity gages accurately and reproducibly have been developed and applied to the determination of detonation behavior of a powdered explosive. The results show that the performance of 80-20 Amatol is sensitive to charge thickness and confinement.

Handbook values of explosive performance are extremely accurate for military explosives at standard densities. When explosives are used in powdered form, at lowered densities, their behavior becomes much more variable, and accurate description of their performance required testing under actual conditions of use.

⁷F. B. Wells, "Some Properties of the Flexible Explosive EL506C, Type 2," Picatinny Arsenal Technical Report 4612 (AD 917792), February 1974.

ACKNOWLEDGEMENTS

This program benefited from the advice and guidance of Dr. Gerald L. Moss. The resurrection of Building 1146 as a firing site by Mr. John R. Stratton greatly expedited the test program, as did his expert contributions to the tests themselves.

REFERENCES

1. B. M. Dobratz, "LLNL Explosives Handbook: Properties of Chemical Explosives and Explosive Simulants," Lawrence Livermore National Laboratory Report No. UCRL-52997, March 1981.
2. L. Penn, F. Helm, M. Finger, and E. Lee, "Determination of Equation of State Parameters for Four Types of Explosives," Lawrence Livermore Laboratory Report No. UCRL-51829, August 1975.
3. B. Crossland and J. A. Cave, Proceedings, 5th International Conference on High Energy Rate Fabrication, University of Denver Research Institute, Colorado, 1975, pp. 4.9.0-4.9.11.
4. M. A. Cook, E. B. Mayfield, and W. S. Partridge, "Reaction Rates of Ammonium Nitrate in Detonation," Journal of Physical Chemistry, 59, 1955, pp. 675-680.
5. H. C. Hoenig, E. L. Lee, M. Finger, and J. E. Kurrle, "Equation of State of Detonation Products," Proceedings, 5th Symposium (International) on Detonation, S. J. Jacobs and R. Roberts, Eds., Superintendent of Documents, Washington, DC, 1970, pp. 503-512.
6. J. Ribovich, R. W. Watson, and F. C. Gibson, "Instrumented Card-Gap Test," AIAA Journal, 6, 1968, pp. 1260-1263.
7. F. B. Wells, "Some Properties of the Flexible Explosive EL506C, Type 2," Picatinny Arsenal Technical Report 4612 (AD 917792), February 1974.

DISTRIBUTION LIST

<u>No. of Copies</u>	<u>Organization</u>	<u>No. of Copies</u>	<u>Organization</u>
12	Administrator Defense Technical Info Center ATTN: DTIC-DDA Cameron Station Alexandria, VA 22314	1	Commander US Army Materiel Command ATTN: AMCDRA-ST 5001 Eisenhower Avenue Alexandria, VA 22333
1	Deputy Assistant Secretary of the Army (R&D) Department of the Army Washington, DC 20310	1	Commander US Army Armament, Munitions and Chemical Command ATTN: SMCAR-ESP-L Rock Island, IL 61299
1	HQDA (DAMA-ART-M) Washington, DC 20310	1	Commander Armament R&D Center US Army Armament, Munitions & Chemical Command ATTN: SMCAR-TSS Dover, NJ 07801
1	HQDA (DAMA-MS) Washington, DC 20310	1	Commander Armament R&D Center US Army Armament, Munitions and Chemical Command ATTN: SMCAR-TDC Dover, NJ 07801
1	Commander US Army Development & Employment Agency ATTN: MODE-TED-SAB Fort Lewis, WA 98433	1	Director Benet Weapons Laboratory Armament R&D Center US Army Armament, Munitions and Chemical Command ATTN: SMCAR-LCB-TL Watervliet, NY 12189
1	Director US Army Ballistic Missile Defense Systems Office 1320 Wilson Boulevard Arlington, VA 22209	1	Commander US Army Aviation Research and Development Command ATTN: AMSAV-E 4300 Goodfellow Blvd. St. Louis, MO 63120
3	Director US Army BMD Advanced Technology Center ATTN: ATC-T, Mr. Capps ATC-M, S. Brockway ATC-RN, P. Boyd P. O. Box 1500, West Station Huntsville, AL 35807	1	Director US Army Air Mobility Research and Development Laboratory Ames Research Center Moffett Field, CA 94035
1	Commander US Army War College ATTN: Lib Carlisle Barracks, PA 17013		
1	Commander US Army Command and General Staff College ATTN: Archives Fort Leavenworth, KS 66027		

DISTRIBUTION LIST

<u>No. of Copies</u>	<u>Organization</u>	<u>No. of Copies</u>	<u>Organization</u>
1	Commander US Army Communications- Electronics Command ATTN: AMSEL-ED Fort Monmouth, NJ 07703	1	Director US Army TRADOC Systems Analysis Activity ATTN: ATAA-SL White Sands Missile Range NM 88002
1	Commander US Army Electronics Research and Development Command Technical Support Activity ATTN: DELSD-L Fort Monmouth, NJ 07703	1	Commander US Army Electronics Research & Development Command ATTN: Tech Lib Fort Huachuca, AZ 85613
1	Commander US Army Harry Diamond Labs ATTN: DRXDO-TI 2800 Powder Mill Road Adelphi, MD 20783	3	Commander US Army Materials and Mechanics Research Center ATTN: DRXMR-T, J. Mescal R. Sinea S. C. Chou Watertown, MA 02172
1	Commander US Army Missile Command ATTN: AMSMI-R Redstone Arsenal, AL 35898	1	Commander US Army Research Office P. O. Box 12211 Research Triangle Park NC 27709-2211
1	Commander US Army Missile Command ATTN: AMSMI-YDL Redstone Arsenal, AL 35898	1	Commandant US Army Infantry School ATTN: ATSH-CD-CSO-OR Fort Benning, GA 31905
2	Commander US Army Mobility Equipment Rsch and Development Command ATTN: STRBE-WC STRBE-RZT Fort Belvoir, VA 22060-5606	1	Office of Naval Research Department of the Navy ATTN: Code 402 Washington, DC 20360
1	Commander US Army Natick Research and Development Center ATTN: AMDNA, Dr. D. Sieling Natick, MA 01760	1	Commander US Naval Surface Weapons Center ATTN: Code Gr-9, Dr. W. Soper Dahlgren, VA 22448
1	Commander US Army Tank Automotive Command ATTN: AMSTA-TSL Warren, MI 48090	1	Air Force Armament Laboratory ATTN: AFATL/DLODL Eglin AFB, FL 32542
1	AFWL/SUL Kirtland AFB, NM 87117		

DISTRIBUTION LIST

<u>No. of Copies</u>	<u>Organization</u>	<u>No. of Copies</u>	<u>Organization</u>
1	Johns Hopkins University ATTN: Prof. W. Sharpe 34th and Charles Streets Baltimore, MD 21218	1.	New Mexico Institute of Mining and Technology Socorro, NM 87801
2	SRI International ATTN: D. Curran L. Seaman 333 Ravenwood Ave. Menol Park, CA 94025	1	University of Denver Denver Research Institute 2390 S. University Boulevard Denver, CO 80201
2	Southwest Research Institute Dept of Mech Sciences ATTN: Dr. W. Baker Dr. U. Lindholm 8500 Culebra Rd. San Antonia, TX 78228		<u>Aberdeen Proving Ground</u> Dir, USAMSAA ATTN: AMXSY-D AMXSY-MP, H. Cohen Cdr, USATECOM ATTN: AMSTE-TO-F Cdr, CRDC, AMCCOM ATTN: SMCCR-RSP-A SMCCR-MU SMCCR-SPS-IL

USER EVALUATION SHEET/CHANGE OF ADDRESS

This Laboratory undertakes a continuing effort to improve the quality of the reports it publishes. Your comments/answers to the items/questions below will aid us in our efforts.

1. BRL Report Number _____ Date of Report _____

2. Date Report Received _____

3. Does this report satisfy a need? (Comment on purpose, related project, or other area of interest for which the report will be used.) _____

4. How specifically, is the report being used? (Information source, design data, procedure, source of ideas, etc.) _____

5. Has the information in this report led to any quantitative savings as far as man-hours or dollars saved, operating costs avoided or efficiencies achieved, etc? If so, please elaborate. _____

6. General Comments. What do you think should be changed to improve future reports? (Indicate changes to organization, technical content, format, etc.) _____

CURRENT
ADDRESS

Name

Organization

Address

City, State, Zip

7. If indicating a Change of Address or Address Correction, please provide the New or Correct Address in Block 6 above and the Old or Incorrect address below.

OLD
ADDRESS

Name

Organization

Address

City, State, Zip

(Remove this sheet along the perforation, fold as indicated, staple or tape closed, and mail.)

FOLD HERE

Director
US Army Ballistic Research Laboratory
ATTN: AMXBR-OD-ST
Aberdeen Proving Ground, MD 21005-5066



NO POSTAGE
NECESSARY
IF MAILED
IN THE
UNITED STATES

OFFICIAL BUSINESS
PENALTY FOR PRIVATE USE, \$300

BUSINESS REPLY MAIL
FIRST CLASS PERMIT NO 12062 WASHINGTON, DC
POSTAGE WILL BE PAID BY DEPARTMENT OF THE ARMY

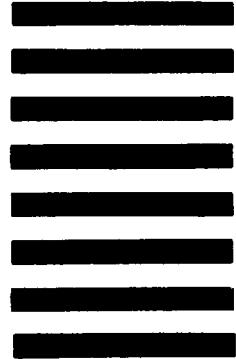

Director
US Army Ballistic Research Laboratory
ATTN: AMXBR-OD-ST
Aberdeen Proving Ground, MD 21005-9989

FOLD HERE