

REPORT DOCUMENTATION PAGE		READ INSTRUCTIONS BEFORE COMPLETING FORM
1. REPORT NUMBER NWC TP 6563	2. GOVT ACCESSION NO.	3. RECIPIENT'S CATALOG NUMBER
4. TITLE (and Subtitle) Maintenance of Photovoltaic Power Systems		5. TYPE OF REPORT & PERIOD COVERED Maintenance Manual
		6. PERFORMING ORG. REPORT NUMBER
7. AUTHOR(s) M. R. Hall		8. CONTRACT OR GRANT NUMBER(s)
9. PERFORMING ORGANIZATION NAME AND ADDRESS Naval Weapons Center China Lake, California 93555		10. PROGRAM ELEMENT, PROJECT, TASK AREA & WORK UNIT NUMBERS NCEL Work Request N6830584WR40045
11. CONTROLLING OFFICE NAME AND ADDRESS Naval Weapons Center China Lake, California 93555		12. REPORT DATE August 1984
		13. NUMBER OF PAGES 69
14. MONITORING AGENCY NAME & ADDRESS (if different from Controlling Office)		15. SECURITY CLASS. (of this report) UNCLASSIFIED
		15a. DECLASSIFICATION/DOWNGRADING SCHEDULE NA
16. DISTRIBUTION STATEMENT (of this Report) Approved for public release; distribution is unlimited.		
17. DISTRIBUTION STATEMENT (of the abstract entered in Block 20, if different from Report)		
18. SUPPLEMENTARY NOTES		
19. KEY WORDS (Continue on reverse side if necessary and identify by block number) Solar energy systems Preventive Maintenance Stand-alone systems Troubleshooting Grid-connected systems Corrective maintenance Photovoltaic power system components		
20. ABSTRACT (Continue on reverse side if necessary and identify by block number) See back of form.		

(U) *Maintenance of Photovoltaic Power Systems*, by M. R. Hall. China Lake, Calif., Naval Weapons Center, August 1984. 69 pp. (NWC TP 6563, publication UNCLASSIFIED.)

(U) This publication establishes standard practices for inspection, testing, and maintenance of photovoltaic power systems at Department of the Navy installations. The practices and procedures are recommended to ensure reliable operation of the power systems. The manual covers photovoltaic-array, battery, voltage-regulator, inverter, and wiring subsystems. In addition, this manual provides a troubleshooting guide and self-study questions and answers.

Maintenance of Photovoltaic Power Systems

by
M. R. Hall
Energy Program Management Office

AUGUST 1984

**NAVAL WEAPONS CENTER,
CHINA LAKE, CA 93555-6001**



Approved for public release; distribution is unlimited.

Naval Weapons Center

AN ACTIVITY OF THE NAVAL MATERIAL COMMAND

FOREWORD

This manual describes the policy and procedures for maintaining photovoltaic power systems at Navy installations. The work was sponsored by the Naval Civil Engineering Laboratory, Port Hueneme, Calif. under Work Request N6830584WR40045. It establishes maintenance standards and provides guidance on identification, isolation, and correction of faults occurring in photovoltaic power systems.

The maintenance standards prescribed have been established to protect personnel and Government property in a manner that facilitates field identification and correction of faults in a timely manner without requiring specialized personnel. The use of these procedures by personnel responsible for maintenance service should ensure uniform, timely, economical, and satisfactory maintenance. Advice concerning any procedure may be obtained from:

Energy Program Office, Code 02A1
Naval Weapons Center
China Lake, California 93555
Autovon 437-3411, ext 225
Commercial (619) 939-3411, ext 225

Recommendations or suggestions for modification, or additional information and instructions that will improve this publication and encourage its use, are invited and should be submitted to the address above.

Approved by
J. R. BOWEN
Deputy Support Director
24 August 1984

Under authority of
K. A. DICKERSON
Capt., U.S. Navy
Commander

Released for publication by
B. W. HAYS
Technical Director

NWC Technical Publication 6563

Published by Technical Information Department
Collation Cover, 36 leaves
First printing 240 copies

NWC TP 6563

CONTENTS

Chapter 1. Introduction	3
1.1 Purpose	3
1.2 Scope	3
1.3 Maintenance Program	4
1.3.1 Inspection	4
1.3.2 Preventive Maintenance	4
1.3.3 Corrective Maintenance	5
1.4 Safety	5
1.5 Maintenance Manual Suggestions	5
Chapter 2. Photovoltaic Power System Description	6
2.1 General	6
2.2 Stand-Alone Photovoltaic Power Systems	6
2.3 Grid-Connected Photovoltaic Power Systems	6
2.4 Photovoltaic Power System Components	8
2.4.1 Photovoltaic Cell	8
2.4.2 Photovoltaic Module	12
2.4.3 Electrical Material	14
2.4.4 Blocking and Bypass Diodes	14
2.4.5 Support Structure	15
2.4.6 Storage Batteries	16
2.4.7 Voltage Regulator	17
2.4.8 Low-Voltage Cutoff	18
2.4.9 Self-Commutated Inverter	18
2.4.10 Line-Commutated Inverter	19
2.4.11 Isolation Transformer	20
Chapter 3. Inspection and Preventive Maintenance of Photovoltaic Power Systems	22
3.1 General	22
3.2 Photovoltaic Module Maintenance	22
3.3 Electrical Subsystem Maintenance	22
3.4 Support Structure Maintenance	23
3.5 Battery Storage Maintenance	23
3.5.1 Safety Warning	23
3.5.2 Cleaning and Inspection	24
3.5.3 Electrolyte	24
3.5.4 Terminal Voltage	24
3.6 Electronic and Power-Conditioning Equipment	25
3.7 Maintenance Checklist	25
Chapter 4. Troubleshooting and Corrective Maintenance of Photovoltaic Power Systems	27
4.1 General	27
4.2 Troubleshooting Guide	27
4.2.1 Stand-Alone Photovoltaic Power Systems	29
4.2.2 Grid-Connected Photovoltaic Power Systems	31

NWC TP 6563

4.2.3	Battery Storage Subsystem	33
4.2.4	Voltage Regulator Subsystem	38
4.2.5	Array Subsystem	46
4.2.6	Inverter Subsystem	49
4.3	Component Failure Form	52
Appendix A: Self-Study Questions on Maintenance of Photovoltaic Power Systems		53
Index		63
Suggestion Form		69

LIST OF FIGURES

Figure	Title	Page
2-1.	Stand-Alone Photovoltaic Power System	7
2-2.	Grid-Connected Photovoltaic Power System	9
2-3.	Construction and Operation of a Photovoltaic Cell	10
2-4.	Typical 3-Inch Silicon Photovoltaic Cell Characteristic Curves	11
2-5.	Effects of Varying Temperature and Solar Radiation Intensity on a Typical Photovoltaic Cell Characteristic Curve	12
2-6.	Photovoltaic Cell Series and Parallel Connections	13
2-7.	Typical Photovoltaic Module Construction	14
2-8.	Operation of a Diode	15
2-9.	Construction of a Typical Lead-Acid Battery	16
2-10.	Series and Parallel Battery Connections	17
2-11.	Typical Voltage Regulators	18
2-12.	Typical Self-Commutated Inverters	19
2-13.	Typical Line-Commutated Inverter	20
2-14.	Typical Isolation Transformer	21
3-1.	Maintenance Checklist	26
4-1.	Troubleshooting Guide Flowchart	28
4-2.	Photovoltaic Power System Connection to Load	29
4-3.	Photovoltaic Power System Connection to Utility Grid	31
4-4.	Measurement of Battery Storage Voltage	33
4-5.	Measurement of Battery Cell Voltage	36
4-6.	Measurement of Battery Cell Specific Gravity	37
4-7.	Measurement of Voltage Regulator Voltage	38
4-8.	Placement of Temperature-Compensating Probe	39
4-9.	Bypassing the Array at the Voltage Regulator	42
4-10.	Measuring the Array Open-Circuit Voltage	43
4-11.	Bypassing the Blocking Diode	44
4-12.	Measuring the Array Short-Circuit Current	48
A-1.	Diagram to be Used for Self-Study Questions 4-2 Through 4-6	60

Chapter 1
INTRODUCTION

1.1 PURPOSE

This manual is a guide for military and civilian personnel who are concerned with the operation, inspection, maintenance, and troubleshooting of photovoltaic power systems.

1.2 SCOPE

This manual describes the operation, inspection, maintenance, and troubleshooting of photovoltaic power systems. Both remote stand-alone and grid-connected photovoltaic power systems are described herein.

Chapter 2 describes the function and configuration of both remote, stand-alone and grid-connected systems. The components that make up these systems will be described individually by their purpose and function. Chapter 3 describes the inspection and preventive maintenance procedures for each photovoltaic power system component. Chapter 4 covers the troubleshooting and corrective-maintenance procedures of the systems in such a manner that a journeyman technician can isolate and identify failures in the systems as well as make minor field repairs.

Because of the large number of manufacturers and models of system components as well as the variety of system designs, this manual is not applicable in every detail to a particular component or system design. Rather, this manual addresses the general procedures to be used with any component or system design.

1.3 MAINTENANCE PROGRAM

An inspection and maintenance program should be developed for photovoltaic power systems to ensure high reliability and availability of the systems. The objective of the maintenance program is the prevention and quick identification of component deficiencies or failures that may lead to overall system failure and the correction of these deficiencies or failures in an economical and timely manner. When a faulty component or condition is identified, it should be corrected as soon as possible. Reliable system operation depends upon the proper operation of each component. The following items should be addressed when developing and implementing a maintenance program.

1.3.1 Inspection

Visual, mechanical, and electrical inspections should be performed on the systems at regular intervals. Inspection intervals for system components that will help ensure long and trouble-free system operation are addressed in Chapter 3. A maintenance checklist is also included at the end of Chapter 3.

1.3.2 Preventive Maintenance

Preventive maintenance is scheduled work that is designed to maintain system component functions at their original performance level. Conscientious adherence to the required maintenance schedules presented in this manual will lead to a long trouble-free system life. Careful inspection of system components during preventive maintenance visits will limit unexpected system failures by identifying potential problems. These procedures are included in Chapter 3.

1.3.3 Corrective Maintenance

Corrective maintenance is unscheduled work that is necessary to identify component or system failures and to return the system performance to its originally designed level. Corrective maintenance will require fault isolation and corrective repairs, and may include component replacement. Corrective maintenance is required because of the catastrophic failure of system components and performance degradation of components caused by aging and environmental stresses. A troubleshooting guide to help isolate and correct system component and design deficiencies is included as Chapter 4 of this manual. A Component Failure Form (see Section 4.3) is provided to record component failures and thereby increase the Navy's component-experience data base.

1.4 SAFETY

Photovoltaic power systems are powered by the sun. If the sun is shining, the system is energized. Extreme caution and awareness should be used when working on photovoltaic power systems. The systems often include battery storage systems that can store lethal amounts of energy. Personnel unfamiliar with photovoltaic power systems should not work on the systems alone. The same caution used with standard electrical circuits should be used when working with photovoltaic power systems.

1.5 MAINTENANCE MANUAL SUGGESTIONS

Photovoltaic power systems are an emerging technology and, as such, situations may arise that are not adequately covered by this manual. If any areas of ambiguity arise, or if any suggestions on improving this manual arise, please complete and return the suggestion form found at the back of this manual.

PHOTOVOLTAIC POWER SYSTEM DESCRIPTION

2.1 GENERAL

Photovoltaic power systems capture solar radiation, convert it to DC power and condition the DC power to meet the load power requirements. The systems supply reliable, quiet, pollution-free power and are a viable, cost-effective alternative to conventional power sources for remote applications. The systems are either stand-alone or grid-connected. Both types will be addressed in this manual.

2.2 STAND-ALONE PHOTOVOLTAIC POWER SYSTEMS

A stand-alone system is one in which no power or system control is obtained from the utility grid; for this reason, the system can be remotely located from all other power sources. The major elements of a stand-alone system are photovoltaic modules, rechargeable batteries, and in most cases a voltage regulator. For loads requiring AC power, an inverter is required to convert the system DC power to the load AC power. All systems contain modules and a load. The systems do not necessarily have to contain voltage regulators, batteries, or inverters. The system configuration depends on the load requirements. Figure 2-1 shows the configuration of a typical stand-alone photovoltaic power system.

2.3 GRID-CONNECTED PHOTOVOLTAIC POWER SYSTEMS

A grid-connected system is one in which inverter control is derived from the utility grid and the power produced is supplied to the

7

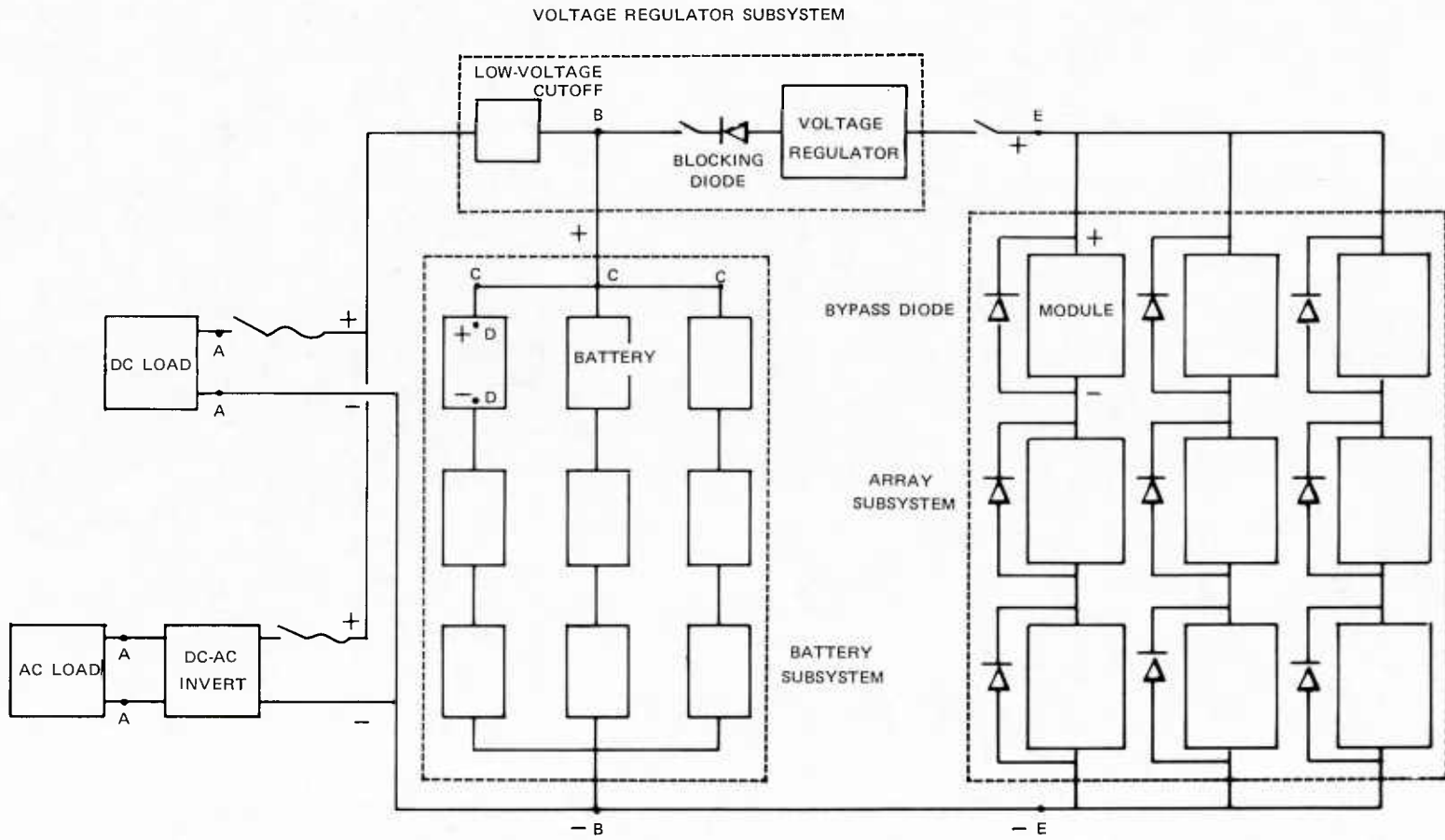

NWC TP 6563

FIGURE 2-1. Stand-Alone Photovoltaic Power System.

utility grid. The major elements of a grid-connected system are photovoltaic modules and a line-commutated inverter. Figure 2-2 shows the configuration of a typical grid-connected photovoltaic power system.

2.4 PHOTOVOLTAIC POWER SYSTEM COMPONENTS

The components found in both stand-alone and grid-connected photovoltaic power systems include the photovoltaic cells and modules, wiring and switches, blocking and bypass diodes, and the system support structure. The components associated with the stand-alone systems only are the storage batteries, voltage regulator, low-voltage cutoff, and the self-commutated inverter. The components associated with the grid-connected systems only are the line-commutated inverter and the isolation transformer. Each of these components is discussed in detail in the following paragraphs.

2.4.1 Photovoltaic Cell

The photovoltaic cell, also known as a solar cell, is the power source for the system. The cell, which converts solar radiation directly into DC power, is made of a semiconducting material with chemical additives that produce a P-N junction near the surface of the material. Solar radiation reaches the earth in discrete amounts of pure energy called photons. When the photons hit the P-N junction near the surface of the material, the photon's energy is used to produce a positive and a negative charge. These charges would recombine if it were not for the P-N junction, which acts as a barrier and keeps the charges apart. The positive charges collect on the P-side of the junction and the negative charges collect on the N-side, creating a voltage potential across the junction. When electrical contacts are added to

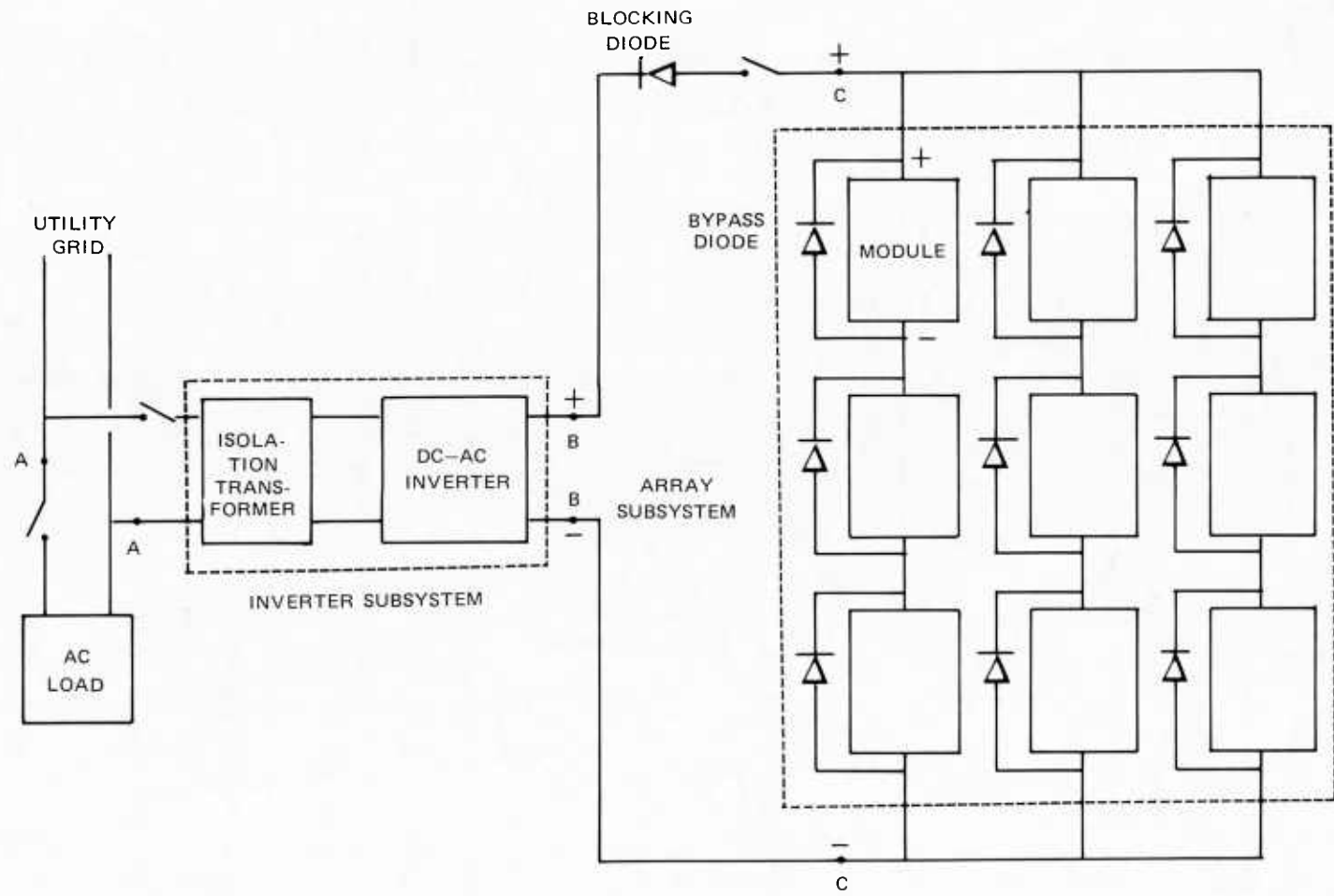

FIGURE 2-2. Grid-Connected Photovoltaic Power System.

the P-side and N-side of the solar cell, this separation of charges can be used to supply power to an external load. The photovoltaic cell can be considered a "solar battery." Like a battery, the cell has positive and negative terminals, and will supply power when connected to an external load. Unlike a battery, the cell cannot store energy, but only supplies energy when exposed to solar energy. The cell is, in effect, a constant-voltage DC generator. Figure 2-3 shows the construction and operation of a photovoltaic cell.

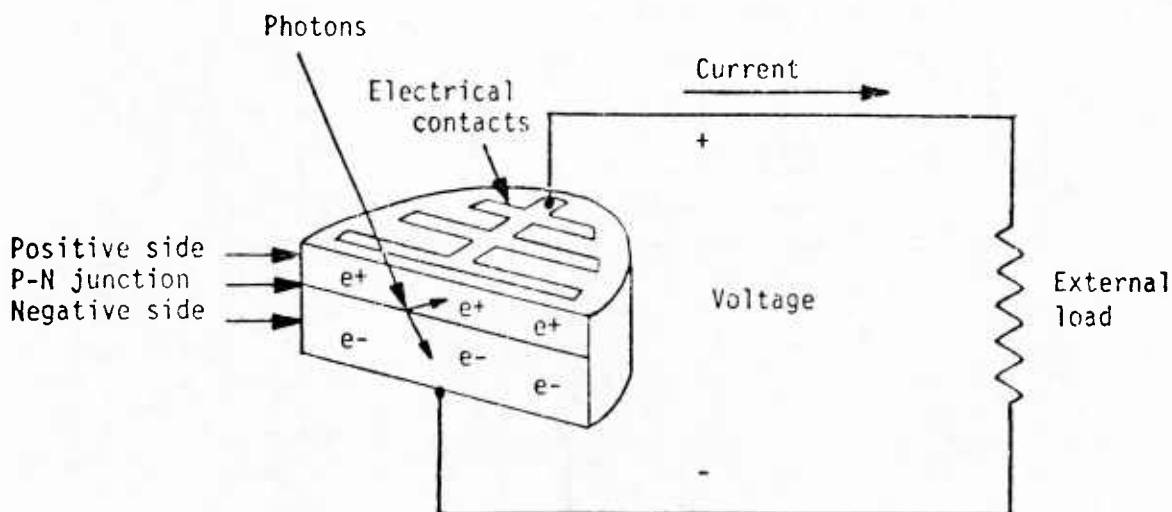

FIGURE 2-3. Construction and Operation of a Photovoltaic Cell.

The photovoltaic cell current is primarily dependent on the amount of solar radiation striking the cell and the exposed cell area. The voltage produced is primarily dependent on the cell temperature. To compare photovoltaic cells from different manufacturers, it is necessary to state the different cell output characteristics under standard conditions of solar radiation and temperature. The photovoltaic industry has agreed to use the following conditions as standard test conditions:

$$\text{Solar radiation striking the cell} = 100 \text{ mW/cm}^2 = 1 \text{ kW/m}^2 \\ (317 \text{ Btu/h}^\circ\text{F})$$

$$\text{Cell operating temperature} = \text{approximately } 27^\circ\text{C (80}^\circ\text{F)}$$

Figure 2-4 shows the typical output of a 3-inch-diameter silicon solar cell under standard test conditions. The cell output is also shown normalized to indicate at what operating point the maximum power is supplied by the cell.

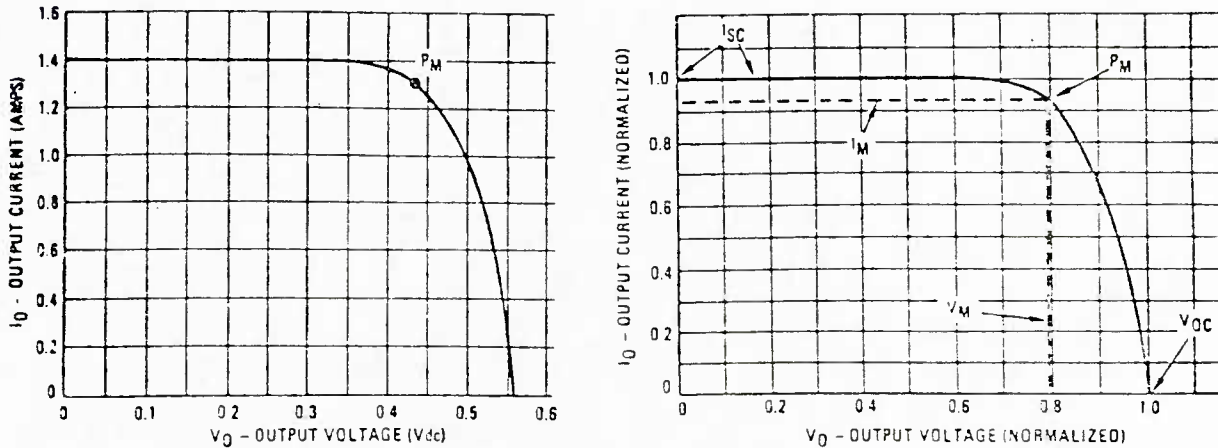

FIGURE 2-4. Typical 3-Inch Silicon Photovoltaic Cell Characteristic Curves.

When the cell's electrical contacts are shorted, the output voltage is zero and the cell supplies the maximum amount of current physically possible. This is the short-circuit current (I_{SC}). When the electrical contacts are opened, the cell is forced to provide the highest voltage possible. This is the open circuit voltage (V_{OC}). The operating voltage, current, and power (power = volts x amperes) supplied by the cell to an external load will depend on the external load's electrical resistance. The photovoltaic cell's operating point will lie on the characteristic curve, and the cell will supply the maximum power to the load at the maximum power point (P_M) on the characteristic curve. I_M and V_M are the current and voltage, respectively, at the maximum power point. The maximum power will be supplied when the load voltage is approximately 80% of the open circuit voltage.

Figure 2-5 shows how the short-circuit current, open-circuit voltage, and maximum power point change with varying solar radiation intensities and cell temperatures.

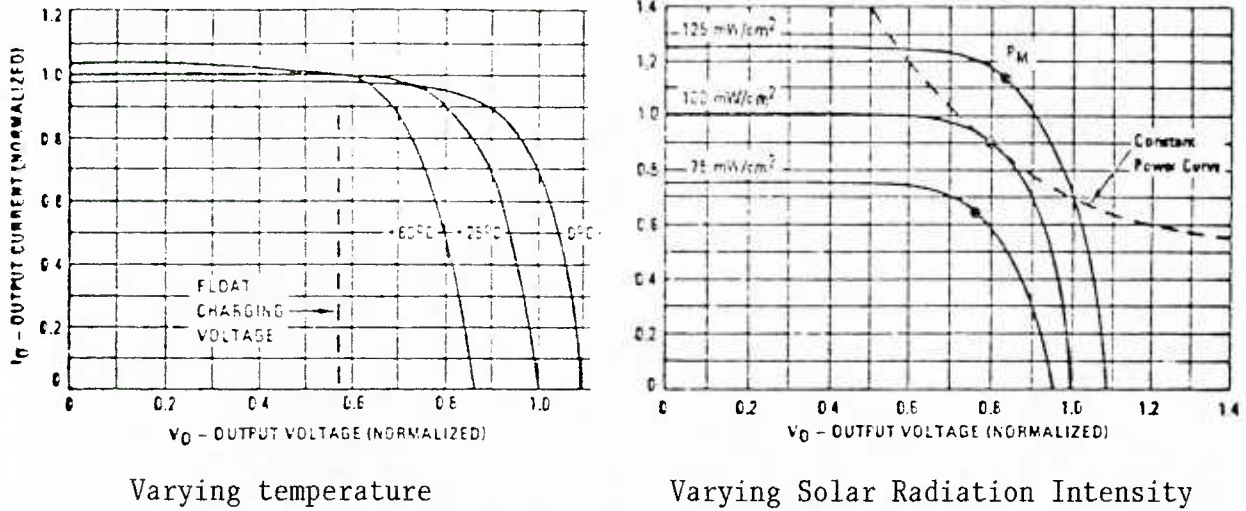

FIGURE 2-5. Effects of Varying Temperature and Solar Radiation Intensity on a Typical Photovoltaic Cell Characteristic Curve.

As stated earlier, the photovoltaic cell acts like a battery because the cells can be connected in series to increase system output voltage or in parallel to increase system output current (Figure 2-6). When photovoltaic cells are connected in series, their output current is the same as for a single cell. When cells are connected in parallel, their output voltage is the same as for a single cell.

2.4.2 Photovoltaic Module

Virtually all photovoltaic power systems require power at a higher output than a single photovoltaic cell. Individual cells are assembled into photovoltaic modules because mounting single cells would be time-consuming and tedious. The modules usually contain 36 to 40 cells connected in series. Modules are easier to handle and quicker to install

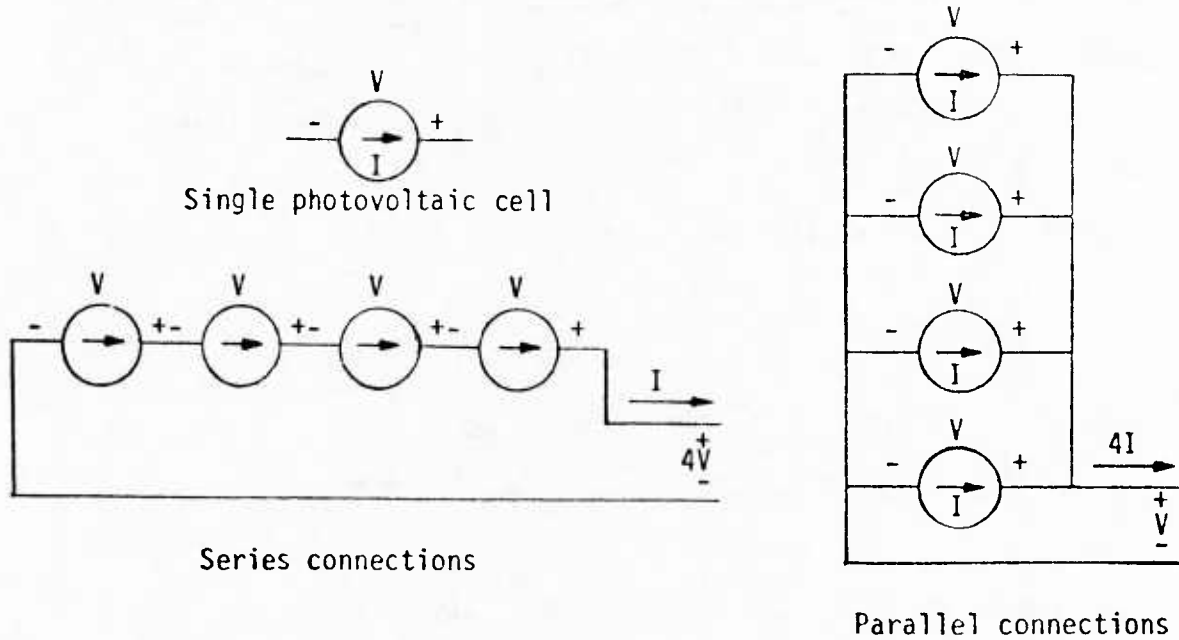

FIGURE 2-6. Photovoltaic Cell Series and Parallel Connections.

than single cells. Like photovoltaic cells, modules can be connected in series for a higher system-output voltage or in parallel for a higher system-output current. A module is electrically no more than a preassembled block of cells and functions to protect the cells from the environment. The module is a sandwich of a superstrate (usually tempered glass), an encapsulant, photovoltaic cells, and a substrate laminated together under pressure and temperature. The lamination protects the cells from damage due to hail, wind, moisture, dirt and handling. Terminals are located on the back of the module to facilitate intermodule electrical connections. The photovoltaic array is the entire field of modules connected in series and in parallel. Figure 2-7 shows the module construction.

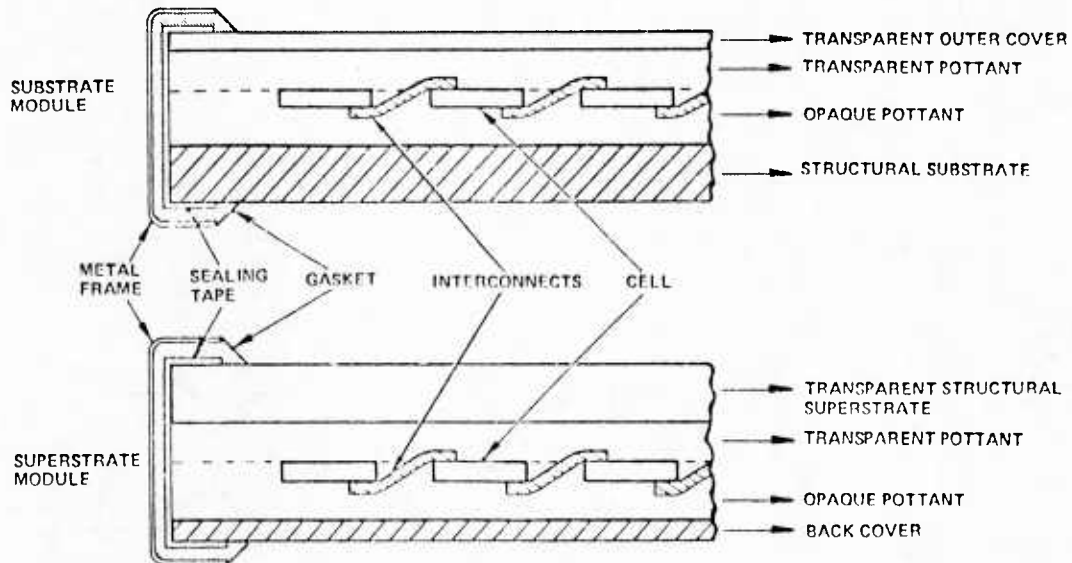

FIGURE 2-7. Typical Photovoltaic Module Construction.

2.4.3 Electrical Material

The electrical material includes circuit breakers, disconnects, wire and cable, plugs, sockets, fuses, and terminals, as well as all conduits, enclosures, and other electrical protection. The electrical material and installation should be in accordance with the National Electrical Code. The circuit breakers, switches, and relays handling DC currents should be designed to handle DC arcs.

2.4.4 Blocking and Bypass Diodes

Diodes are solid-state electronic devices that let current in a circuit flow in only one direction. The diode allows current to flow in the direction of the "arrow" when the voltage at the back of the

arrow is positive with respect to the front of the arrow, but does not allow the current to flow in the reverse direction (see Figure 2-8). Blocking diodes are used to allow current to flow from the array and voltage regulator to the batteries, but they prevent the batteries from losing current at night through the array and voltage regulator. Bypass diodes are included in some module designs to enhance the array reliability. The bypass diode allows the current in a series string to flow around a module in the event that the module is damaged and stops producing power. Without the bypass diode, the power produced by the entire series string would be lost. With the bypass diode, only the power of the damaged module is lost.

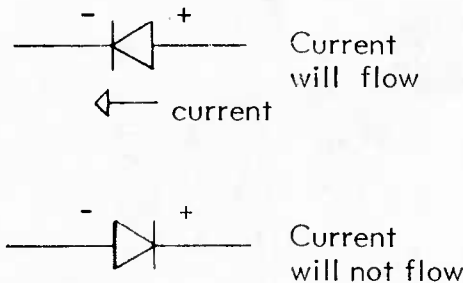

FIGURE 2-8. Operation of a Diode.

2.4.5 Support Structure

The support structure is a rigid material used to hold the array in a fixed position. This material is usually steel or aluminum, but may be wood or other metals. The material used should be painted or protected to prevent rusting and deterioration of the support structure. When dissimilar metals are used, a means should be employed to prevent galvanic corrosion.

2.4.6 Storage Batteries

The battery storage is used to store energy produced by the array and not used by the load, and also is used to supply power to the load at night and on cloudy days. The ideal storage battery for a photovoltaic power system must hold a charge (have a low self-discharge) for an extended period of time. The battery must be able to survive a number of cycles of deep discharge and subsequent recharge, and must also have a long life with very little maintenance. The most commonly used storage battery is the lead-acid battery. Figure 2-9 shows the construction of a typical lead-acid battery.

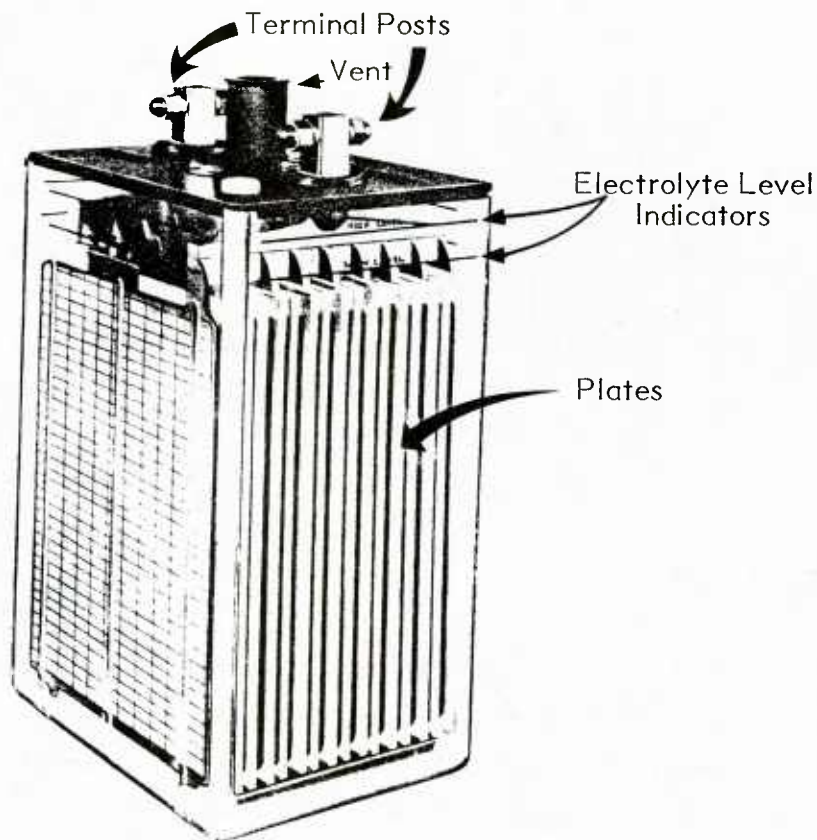

FIGURE 2-9. Construction of a Typical Lead-Acid Battery.

Storage batteries are connected in series to increase the battery storage voltage and in parallel to increase the battery storage current. The current supplied by a series string of batteries will be the

same as the current supplied by a single battery. The voltage supplied by parallel-connected batteries will be the same as the voltage supplied by a single battery. Figure 2-10 shows series and parallel battery connections.

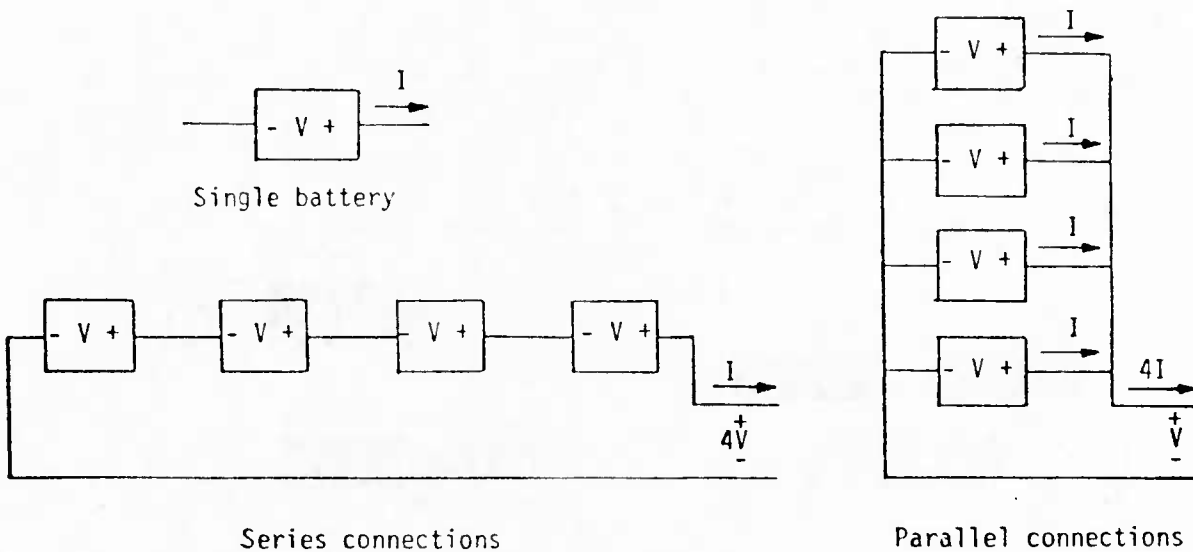

FIGURE 2-10. Series and Parallel Battery Connections.

A higher voltage is required to charge a storage battery than is available to the load from the battery. The voltage difference between the charging and operating voltage is an inefficiency associated with battery storage systems. The charging voltage required by a battery will change with temperature. As the temperature drops, the required charging voltage increases and vice versa.

2.4.7 Voltage Regulator

The voltage regulator is an electronic device that adjusts the output voltage from the array to meet the requirements of the battery storage. The voltage regulator adjusts the input voltage to the battery storage to maximize the battery charging, while at the same time

limiting battery water loss due to battery outgassing caused by overcharging. The voltage regulator may be temperature-compensating to adjust to the battery charging requirements as they vary with temperature. Figure 2-11 shows some typical voltage regulators.

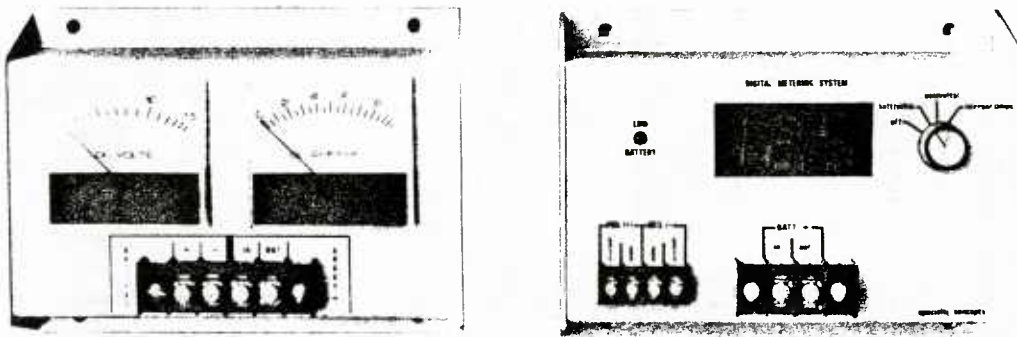

FIGURE 2-11. Typical Voltage Regulators.

2.4.8 Low-Voltage Cutoff

A low-voltage cutoff is used to disconnect the battery storage from the load to prevent damage to the batteries from being discharged too deeply.

2.4.9 Self-Commutated Inverter

The self-commutated inverter is a solid-state device that takes DC power from the battery storage and converts it to AC power. The inverter supplies AC power of the proper frequency, voltage, and quality to meet the requirements of the load, and can supply 1- or 3-phase

power. The inverter does not require any outside signals to control the AC power. The inverters range in output from a few watts to many kilowatts. Figure 2-12 shows typical self-commutated inverters.

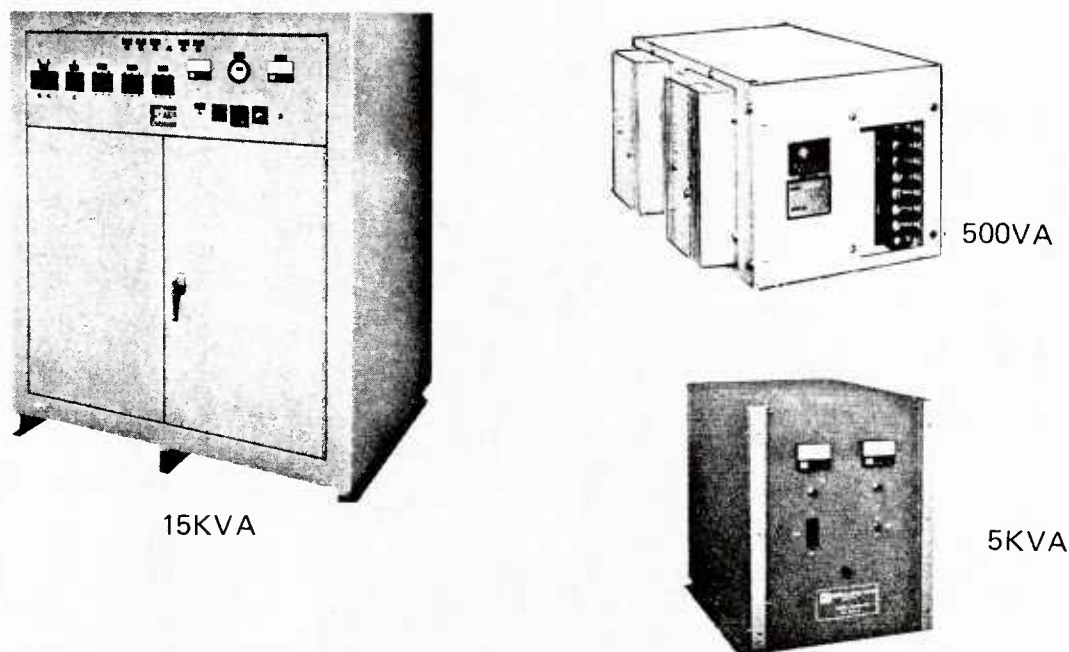

FIGURE 2-12. Typical Self-Commutated Inverters.

2.4.10 Line-Commutated Inverter

The line-commutated inverter is a solid-state device that takes the varying DC voltage from the array and converts it to AC power. The inverter is connected to the utility grid and delivers AC power of the proper voltage, frequency, and quality to the grid. The inverter requires a signal from the utility grid to properly invert the DC power to AC power and cannot operate disconnected from the grid. As a safety feature, to prevent power from being supplied to a utility grid when the grid is shut off for maintenance, a normally open relay that is

energized by the grid disconnects the array from the inverter when the grid power goes off. Line-commutated inverters range in size from a few kilowatts to hundreds of kilowatts in output power. Figure 2-13 shows a typical line-commutated inverter.

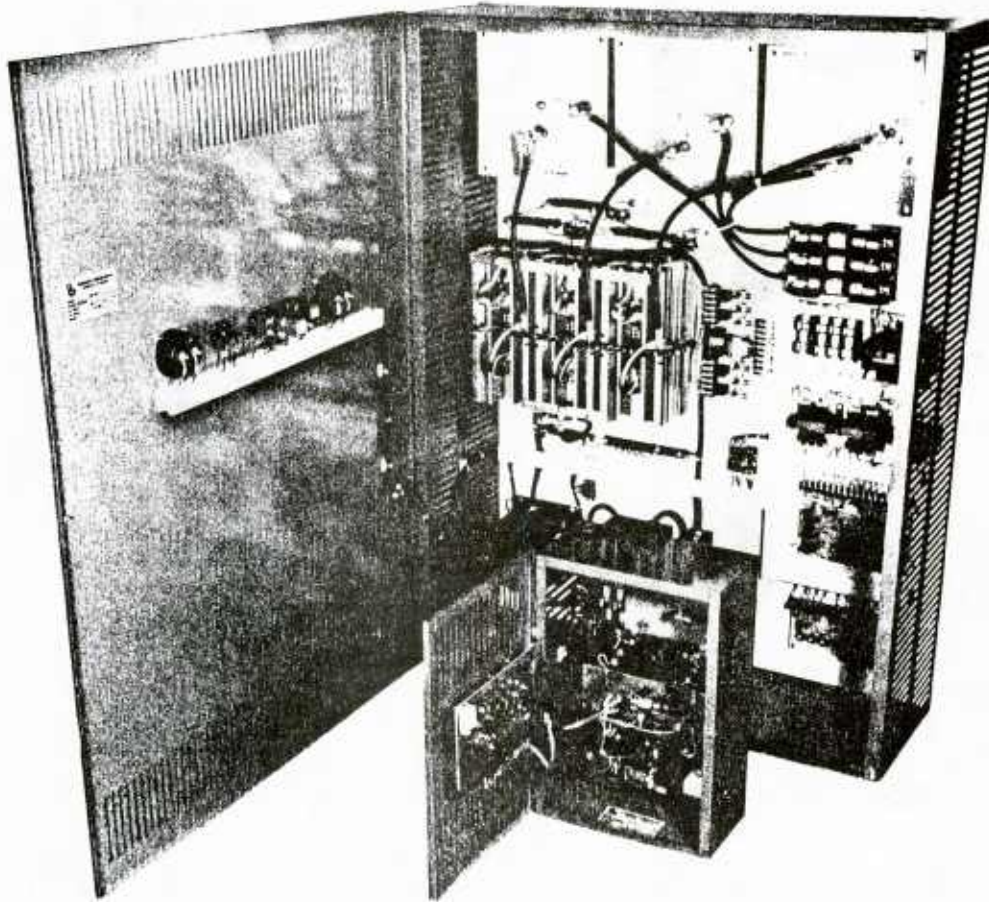

FIGURE 2-13. Typical Line-Commutated Inverter.

2.4.11 Isolation Transformer

An isolation transformer is used to electrically isolate the array-inverter from the utility grid. If a DC short circuit were to occur in the line-commutated inverter, DC voltages could not be transmitted to the utility grid. Figure 2-14 shows a typical isolation transformer.



FIGURE 2-14. Typical Isolation Transformer.

Chapter 3

INSPECTION AND PREVENTIVE MAINTENANCE
OF PHOTOVOLTAIC POWER SYSTEMS

3.1 GENERAL

This chapter covers the routine maintenance requirements of photovoltaic power systems. The requirements of each system component are addressed. A summary of the required maintenance procedures and schedules can be found at the end of the chapter. A DC voltmeter is the only test equipment required.

3.2 PHOTOVOLTAIC MODULE MAINTENANCE

A visual inspection of the photovoltaic modules should be performed every 6 months. Inspect the modules for cracked surfaces, delamination, and other structural failures. Should any structural failures be found, conduct troubleshooting Array Subsystem Tests 1 and 2 (4.2.5) to determine if any module degradation is present. Wind and rain should keep the modules clean. If the modules are excessively dirty, wash the module surface with water. A mild detergent may be used if necessary. Wash the modules early in the morning to prevent damage to the modules from the thermal shock of the cold water hitting the hot modules.

3.3 ELECTRICAL SUBSYSTEM MAINTENANCE

The electrical material and diodes are grouped together to form the electrical subsystem. The only required maintenance consists of a visual inspection once every 6 months to check for signs of switch and

relay arcing, broken or frayed insulation, and corroded or loose wire connections. Should any of the above conditions be present, clean or replace the components as necessary. Any components that exhibit greater than normal wear should be brought to the notice of the Energy Program Office by completing the Component Failure Form at the end of Chapter 4.

3.4 SUPPORT STRUCTURE MAINTENANCE

A visual inspection of the support structure should be conducted every 6 months to check for corrosion or rotting of structural members and for loose fasteners. Special attention must be given to the area around the battery storage, which may have come in contact with battery acid spills or fumes.

3.5 BATTERY STORAGE MAINTENANCE

Battery storage maintenance should be conducted every 6 months, or more often if required by the batteries. Maintenance consists of cleaning all corroded terminals, tightening terminals, adjusting electrolyte level, and a visual inspection for structural and operational problems.

3.5.1 Safety Warning

Gases produced by a battery can be explosive. Do not smoke, use an open flame, or create an arc or sparks in the vicinity of any battery. Batteries contain sulfuric-acid electrolyte, which may cause severe burns. Do not get electrolyte in the eyes, or on the skin or

clothing. In case of contact, flush the area immediately and thoroughly with clean water. Obtain medical attention as soon as possible when the eyes are affected. Bicarbonate of soda solution (1 pound to 1 gallon of water) will neutralize any acid spills. Apply the solution until the bubbling stops, then rinse with clean water. Battery cells connected in series have high voltages that could produce lethal shocks. Use caution and insulated tools when working on batteries.

3.5.2 Cleaning and Inspection

Clean all corroded terminals with a brush and bicarbonate of soda solution. Tighten the terminal connections after cleaning and protect the terminals with an anti-corrosion grease (Vaseline will work). Check for any frayed or damaged wires and for electrolyte spills that would indicate a possible leak or excessive battery charging.

3.5.3 Electrolyte

Add pure distilled water only to the electrolyte to bring the electrolyte to the level required by the battery. In all cases the electrolyte must be above the top of the battery plates to ensure proper battery performance and life. When working with the battery electrolyte, avoid contamination by foreign substances. If a hydrometer is used, it should be dedicated to one battery model only, which will eliminate the possibility of contamination from other types of batteries.

3.5.4 Terminal Voltage

Measure the battery-storage terminal voltage (test points B, Figure 2-1) to ensure that the battery storage is operating within its

NWC TP 6563

designed voltage range. If the battery storage terminal voltage is not within its operating range, go to Chapter 4, Section 4.2.3, Battery Subsystem and start with Test 1. Fill out a Component Failure Form found at the end of Chapter 4 for any battery failures.

3.6 ELECTRONIC AND POWER-CONDITIONING EQUIPMENT

The voltage regulator, low-voltage cutoff, self-commutated inverter, line-commutated inverter, and isolation transformer are the electronic and power-conditioning equipment. The only preventive maintenance required by this equipment is a visual inspection to look for burnt or frayed wires and loose connections, and external cleaning of dirt that may accumulate. Operational tests for this equipment are described in Chapter 4.

3.7 MAINTENANCE CHECKLIST

Figure 3-1 is a maintenance checklist to facilitate preventive maintenance actions.

NWC TP 6563

PPS PREVENTIVE MAINTENANCE

PPS TITLE _____ DATE _____

LOCATION _____ INSPECTOR _____

NOTE: PREVENTIVE MAINTENANCE REQUIRED EVERY 6 MONTHS.

PHOTOVOLTAIC MODULES:

CRACKED SURFACES: NO YES HOW MANY? _____

DELAMINATION: NO YES DESCRIBE _____

OTHER STRUCTURAL FAILURES: NO YES DESCRIBE _____

MODULES CLEANED: NO YES

ELECTRICAL SUBSYSTEM:

SWITCH OR RELAY ARCING: NO YES DESCRIBE _____

DAMAGED INSULATION: NO YES DESCRIBE _____

CORRODED OR LOOSE WIRES: NO YES DESCRIBE _____

SUPPORT STRUCTURE:

CORROSION OR ROTTING: NO YES DESCRIBE _____

LOOSE FASTENERS: NO YES DESCRIBE _____

BATTERY STORAGE:

CLEANED AND TIGHTENED TERMINALS: NO YES HOW MANY? _____

ADJUST ELECTROLYTE LEVEL: NO YES HOW MUCH? _____

TERMINAL VOLTAGE: _____ VOLTS DC

VOLTS PER CELL: _____ VOLTS DC

ELECTRONIC AND POWER CONDITIONING EQUIPMENT:

DAMAGED OR LOOSE WIRES: NO YES DESCRIBE _____

EXTERIOR CLEANED: NO YES DESCRIBE _____

FIGURE 3-1. Maintenance Checklist.

Chapter 4

TROUBLESHOOTING AND CORRECTIVE MAINTENANCE
OF PHOTOVOLTAIC POWER SYSTEMS

4.1 GENERAL

The troubleshooting and corrective maintenance section will enable the user to isolate the fault of an inoperable photovoltaic power system and to make field-repairable corrections. The system components are separated into battery storage, voltage regulator, array, and inverter subsystems. The following procedures apply to photovoltaic power systems in general and may not be applicable in every detail to a particular component or design. The flowchart in Figure 4-1 will aid in identifying and correcting faults. A DC voltmeter and a DC clamp-on current meter are the only pieces of test equipment required.

When a faulty component is identified and corrected, complete the Component Failure Form (Section 4.3) at the end of this chapter. If a difficulty arises in identifying and correcting a system fault, contact the Energy Program Office at AUTOVON 437-3411, ext. 225, or commercial (619) 939-3411, ext. 225.

4.2 TROUBLESHOOTING GUIDE

The user begins the troubleshooting procedure with Test 1 of either the stand-alone system section or grid-connected system section. The user then follows the instructions of each corrective action in sequence until the fault is identified and corrected. The corrective action will direct the user to each subsystem section when necessary. More than one fault may be present, and it may be necessary to follow the above procedure more than once.

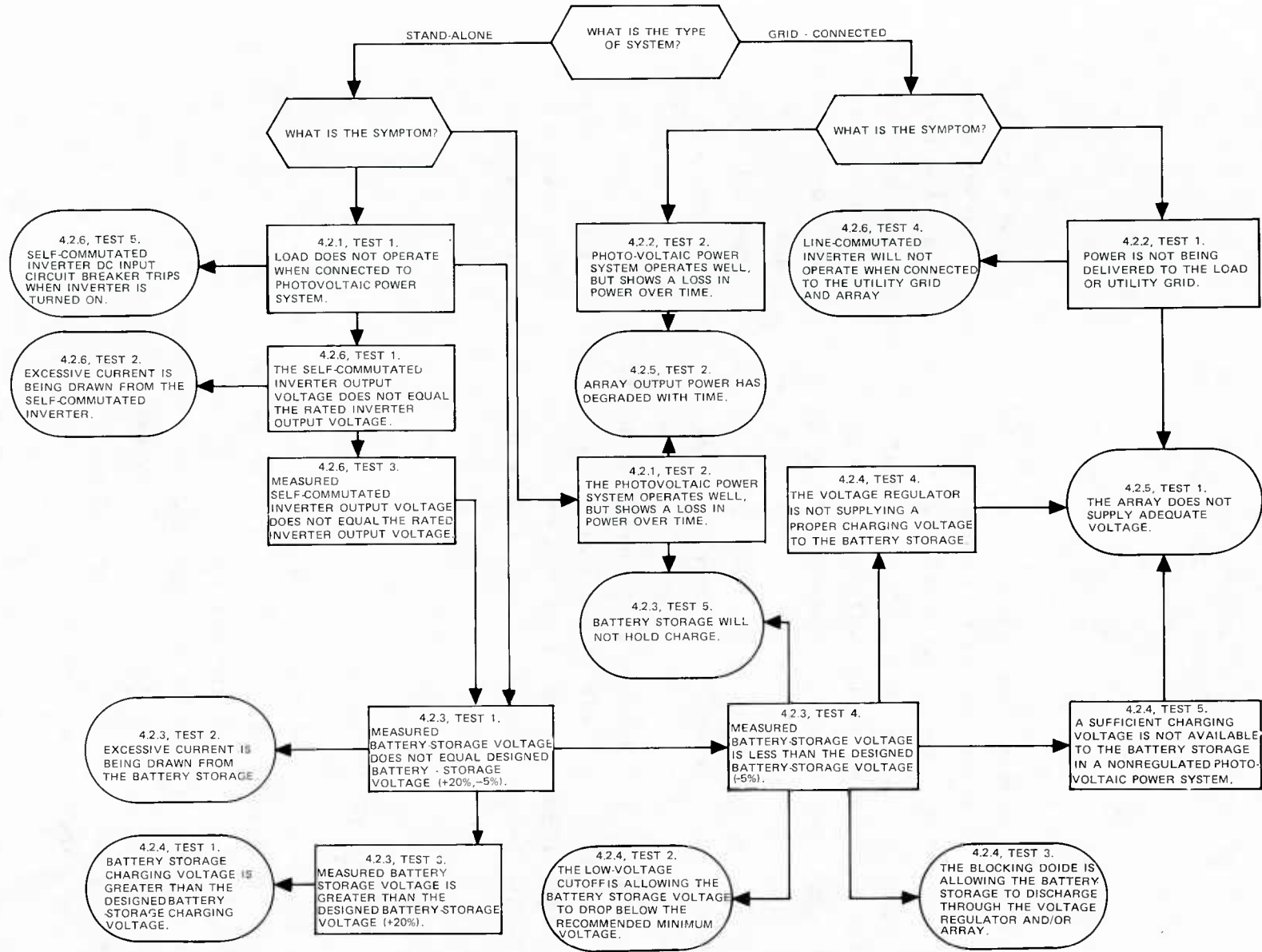

FIGURE 4-1. Trouble-Shooting Guide Flow Chart.

Prior to beginning any corrective maintenance actions, perform the preventive maintenance procedures described in Chapter 3. Also, check the fuses to ensure their integrity and check switches and circuit breakers for proper orientation and operability.

4.2.1 Stand-Alone Photovoltaic Power Systems

<u>Test</u>	<u>Action</u>
1. Load does not operate when connected to photovoltaic power system.	a. Turn load switch on. b. Check polarity (if any) and wire connections of the system at the load (test points A in Figure 2-1). (See Figure 4-2.) Clean and tighten wires if necessary.

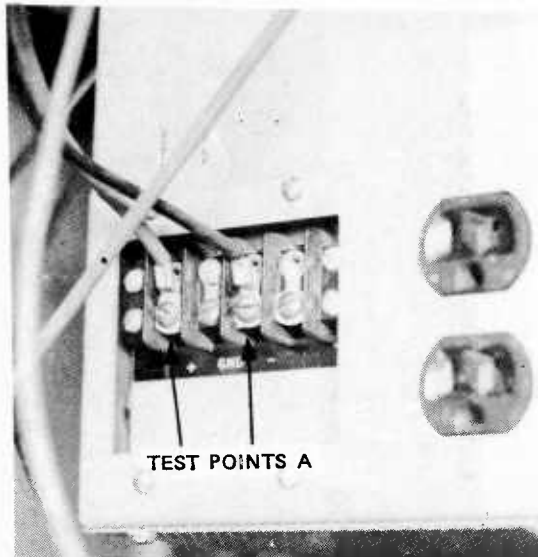

FIGURE 4-2. Photovoltaic Power System Connection to Load.

- c. Measure input voltage of system at load terminals (test points A). If the measured voltage equals the

4.2.1 (Contd.)

<u>Test</u>	<u>Action</u>
1. c. (Contd.)	<p>battery-storage design voltage (+20%, -5%) for DC systems, or the rated inverter output voltage for AC systems, the photovoltaic power system is okay and the fault is in the load, or the load is too large or not designed to operate on the system voltage.</p> <p>d. If the measured voltage does not equal the battery-storage design voltage (+20%, -5%) for DC systems, or the rated inverter-output voltage for AC systems, go to Battery Storage Subsystem (4.2.3), Test 1, for DC systems or Inverter Subsystem (4.2.6), Test 1, for AC systems.</p> <p>e. If the measured input voltage is 0 volts at the load terminals, a fuse, circuit breaker and/or a disconnect is faulty or out of position and should be checked. Go to Inverter Subsystem (4.2.6), Test 5, for AC systems. If all fuses and disconnects are okay, check wires for internal breaks or corrosion.</p>
2. The photovoltaic power system operates well, but shows a loss in power over time.	<p>a. Loss in power is due to degradation of battery storage or a drop in the array output. Go to Battery-Storage Subsystem (4.2.3), Test 5, to determine battery-storage degradation.</p>

4.2.1 (Contd.)

<u>Test</u>	<u>Action</u>
2. a. (Contd.)	Go to Array Subsystem (4.2.5), Test 2, to determine drop in array output.

4.2.2 Grid-Connected Photovoltaic Power Systems

<u>Test</u>	<u>Action</u>
1. Power is not being delivered to the load or utility grid.	a. Turn on the inverter and the circuit breaker connecting the inverter subsystem to the utility grid. The inverter is connected to the utility grid through a circuit breaker and system neutral. (See Figure 4-3.)

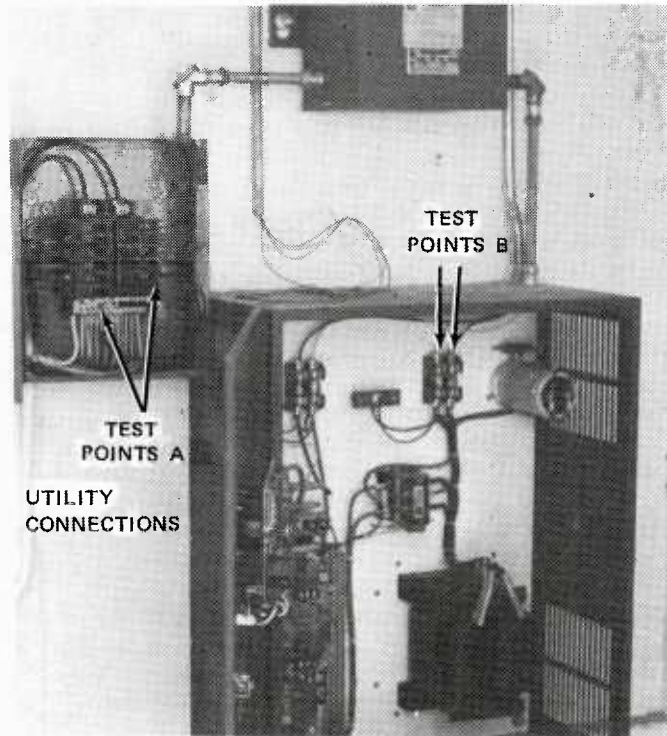

FIGURE 4-3. Photovoltaic Power System Connection to Utility Grid.

4.2.2 (Contd.)

<u>Test</u>	<u>Action</u>
1. (Contd.)	<ul style="list-style-type: none"> b. Measure the voltage at the output of the isolation transformer (test points A in Figure 2-2) to verify that utility power is on at the transformer and inverter. (See Figure 4-3.) The inverter will not operate without utility power. If no utility power is present, check the circuit box circuit breakers or contact the local utility company for assistance. c. If utility power is being supplied to the inverter (the transformer will hum and vibrate), measure the array input voltage at the inverter (test points B in Figure 2-2). (See Figure 4-3.) d. If the array input voltage is within the inverter specified limits, the inverter is faulty. Go to Inverter Subsystem (4.2.6), Test 4. If the array input voltage is not within the inverter specified limits, go to Array Subsystem (4.2.5), Test 1.
2. Photovoltaic power system operates well, but shows a loss in power over time.	<ul style="list-style-type: none"> a. Loss in power is due to a drop in the array output. Go to Array Subsystem (4.2.5), Test 2, to determine whether a drop in array output exists.

4.2.3 Battery-Storage Subsystem

<u>Test</u>	<u>Action</u>
<p>1. Measured battery-storage voltage does not equal designed battery-storage voltage (+20%, -5%)</p>	<p>a. Disconnect inverter or load and the array.</p> <p>b. Measure the battery-storage voltage (test points B, Figure 2-1). (See Figure 4-4.)</p>

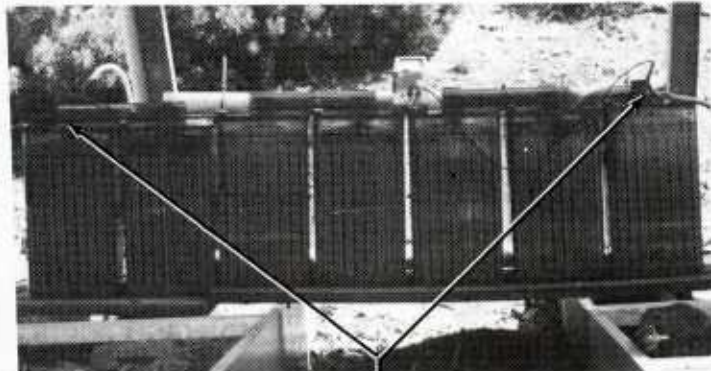

TEST POINTS B.

FIGURE 4-4. Measurement of Battery Storage Voltage.

- c. If the voltage is equal to the design battery-storage voltage (+20%, -5%), excessive current is being drawn from the battery-storage. Go to Test 2.
- d. If the voltage is still not equal to the design battery-storage voltage (+20%, -5%) go to Test 3 or Test 4.

4.2.3 (Contd.)

<u>Test</u>	<u>Action</u>
2. Excessive current is being drawn from the battery storage.	<ul style="list-style-type: none">a. Check load (DC systems) or inverter (AC systems) for internal short circuits. If no short circuits are found, the load is too large for the system and must be removed, or the system must be redesigned. Contact the Energy Program Office for assistance.b. If the load (DC systems) has a short circuit, correct the load. The system is okay.c. If the inverter (AC systems) is found faulty, contact the inverter manufacturer for further assistance.
3. Measured battery-storage voltage is greater than the designed battery-storage voltage (+20%).	<ul style="list-style-type: none">a. If the photovoltaic power system includes a voltage regulator, the voltage regulator is faulty. Go to Voltage Regulator Subsystem (4.2.4), Test 1.b. If the photovoltaic power system does not include a voltage regulator, the battery storage and array sizes are not properly designed. Contact the Energy Program Office for assistance.
4. Measured battery storage voltage is less than the designed battery-storage voltage (-5%).	<ul style="list-style-type: none">a. The load is drawing power too long and the battery-storage is not being disconnected from the load. The low-voltage cutoff is absent or

4.2.3 (Contd.)

<u>Test</u>	<u>Action</u>
4. a. (Contd.)	faulty. Go to Voltage Regulator Subsystem (4.2.4), Test 2.
	b. The blocking diode is absent or faulty, allowing power to be lost in the voltage regulator and/or the array. Go to Voltage Regulator Subsystem (4.2.4), Test 3.
	c. The voltage regulator is not charging the battery storage. Go to Voltage Regulator Subsystem (4.2.4), Test 4.
	d. The battery storage will not hold a charge. Go to Test 5.
	e. The array is not supplying power to the battery storage in nonregulated photovoltaic power systems. Go to Voltage Regulator Subsystem (4.2.4), Test 5.
5. Battery-storage will not hold charge.	a. Disconnect battery cables from positive (+) terminal of battery storage (test points C, Figure 2-1).
	b. Measure and record each battery cell voltage (test points D, Figure 2-1). (See Figure 4-5.) Any battery cell that has a voltage which is 10% lower than the average cell voltage is suspect and should be replaced.

4.2.3 (Contd.)

Test

Action

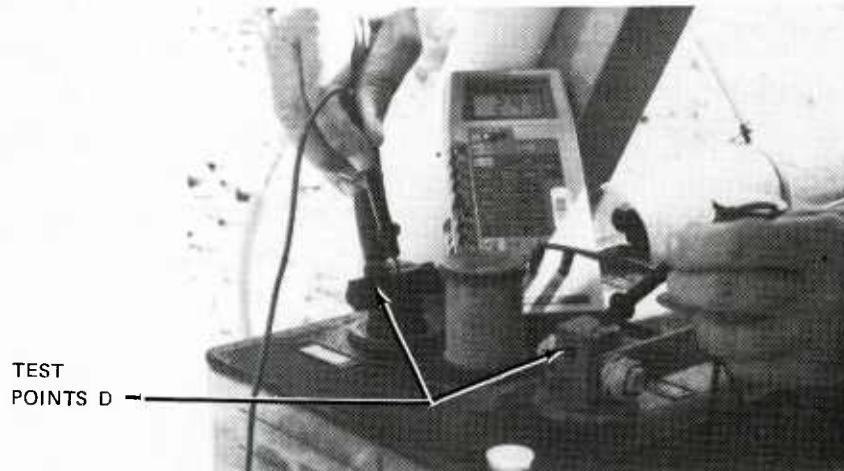

FIGURE 4-5. Measurement of Battery Cell Voltage.

5. (Contd.)

- c. Measure and record each battery cell's specific gravity. (See Figure 4-6.) Any battery cell that has a specific gravity 10% lower than the average specific gravity is suspect and should be replaced.
- d. If all battery cell voltages and specific gravities are within 10%, and the voltage regulator and array are operating properly, connect the voltage regulator and array to the battery storage to charge the battery bank. Monitor the battery-storage voltage to verify battery-storage charging. After the battery

4.2.3 (Contd.)

Test

Action

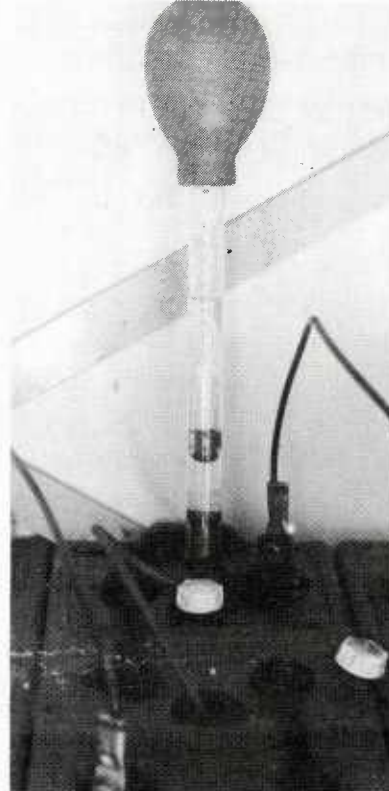

FIGURE 4-6. Measurement of Battery Cell Specific Gravity.

5. d. (Contd.)

storage has been charged to at least 20% of capacity, disconnect the battery storage from the voltage regulator and the load and monitor the battery-storage voltage. If the voltage drops by more than 0.5% per day, the entire battery storage is suspect and should be replaced.

- e. All suspect battery cells should be taken to a battery shop for further testing.

4.2.4 Voltage Regulator Subsystem

<u>Test</u>	<u>Action</u>
1. Battery-storage charging voltage is greater than the designed battery-storage charging voltage.	a. Consult the battery-storage manual to determine the proper upper cutoff voltage. b. Measure the actual voltage regulator upper cutoff voltage by observing the voltage (test points B, Figure 2-1) at which the voltage regulator cuts off the charging cycle. (See Figure 4-7.) This is accomplished by disconnecting the load from the batteries and waiting for the batteries to become fully charged.

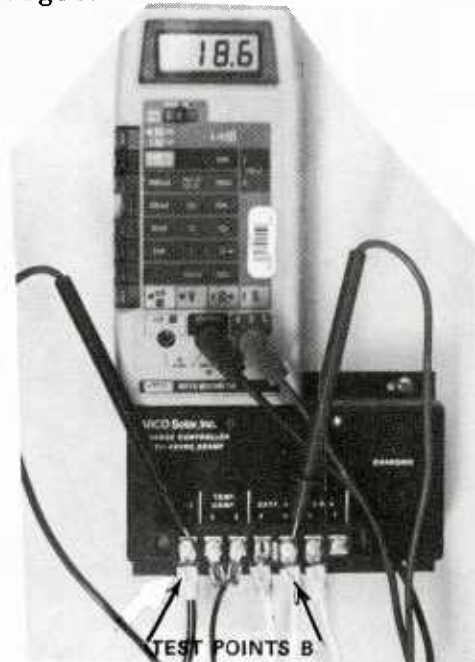

FIGURE 4-7. Measurement of Voltage Regulator Voltage.

4.2.4 (Contd.)

<u>Test</u>	<u>Action</u>
1. (Contd.)	<p>c. When the voltage regulator upper cutoff voltage is high, and a temperature-compensating probe is used, check to ensure the probe is accurately indicating battery temperature. (See Figure 4-8.) Consult the manufacturer or voltage regulator manual to properly adjust upper cutoff voltage if possible.</p> <p>d. For sealed nonadjustable voltage regulators, replace the unit and contact the manufacturer for further assistance.</p>



FIGURE 4-8. Placement of Temperature-Compensating Probe.

4.2.4 (Contd.)

<u>Test</u>	<u>Action</u>
<p>2. The low-voltage cutoff is allowing the battery-storage voltage to drop below the recommended minimum voltage.</p>	<p>a. Disconnect the load (and inverter). Allow the battery storage to charge to at least 20% of capacity. Reconnect the load (and inverter).</p> <p>b. Monitor battery-storage and load voltages and observe if the low-voltage cutoff is disconnecting the load (and inverter) at the required low voltage level of the battery storage.</p> <p>c. If the low-voltage cutoff disconnects the load (and inverter) at the proper voltage, the low-voltage cutoff is operating properly.</p> <p>d. If the low-voltage cutoff does not disconnect the load (and inverter) at the proper voltage, the low-voltage cutoff is absent or faulty. Consult the low-voltage cutoff manual or manufacturer for information on adjusting or correcting the low-voltage cutoff level.</p> <p>e. If the low-voltage cutoff cannot be corrected, it must be replaced. Contact the manufacturer for further assistance.</p>

4.2.4 (Contd.)

<u>Test</u>	<u>Action</u>
3. The blocking diode is allowing the battery storage to discharge through the voltage regulator and/or array.	<p>a. Measure the voltage across the diode (positive is on the array side) when current is flowing from the array to the battery storage or load. If the measured voltage is between 0.5 and 1.0 volt, the diode is good, otherwise the diode must be replaced.</p> <p>b. Disconnect the load (and inverter). Allow the battery storage to charge to at least 20% of capacity. Disconnect the array at test points E (Figure 2-1) and connect the test points together (thus bypassing the array and simulating a night condition). (See Figure 4-9.)</p> <p>c. Measure the current flowing in the wire from the battery to the blocking diode. If more than a few milliamperes are flowing to the blocking diode, the diode is bad and must be replaced. If no measurable current is flowing to the blocking diode, the diode is good. If the diode is faulty and located inside a voltage regulator, the voltage regulator must be replaced.</p>

4.2.4 (Contd.)

Test

Action

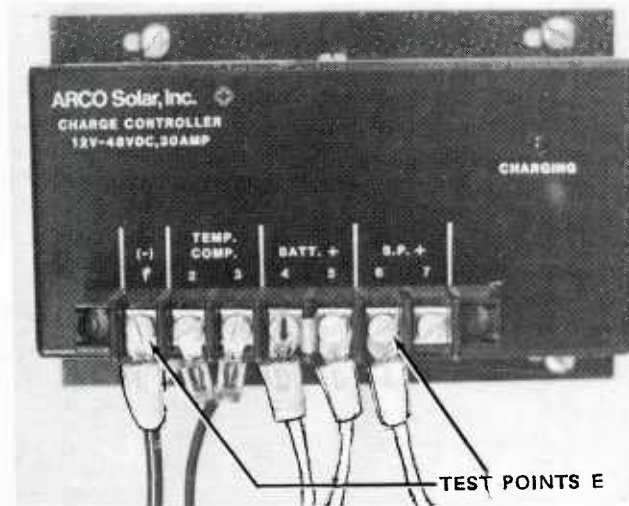

FIGURE 4-9. Bypassing the Array at the Voltage Regulator.

4. The voltage regulator is not supplying a proper charging voltage to the battery storage.
 - a. Disconnect the array from the voltage regulator. Measure the array open-circuit voltage (test points E, Figure 2-1) on a clear sunny day. (See Figure 4-10.) If the open-circuit voltage is greater than the required battery-storage charging voltage, the array is supplying sufficient power to the voltage regulator. Go to Action b. If the open-circuit voltage is less than the required battery-storage charging voltage, go to Array Subsystem (4.2.5), Test 1.

4.2.4 (Contd.)

Test

Action

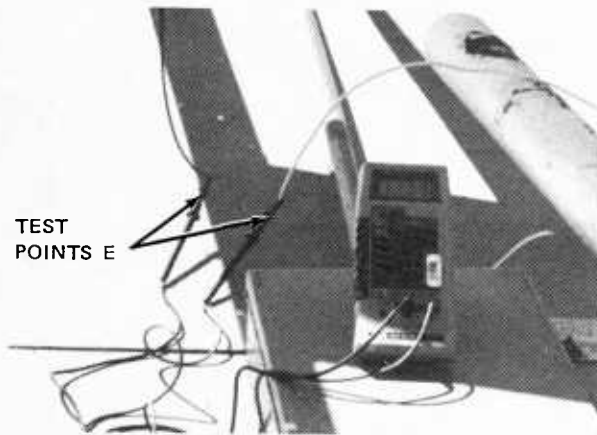

FIGURE 4-10. Measuring the Array Open-Circuit Voltage.

4. (Contd.)

- b. Reconnect the array to the voltage regulator, observing the proper polarity.
- c. Connect a wire from the blocking-diode input to its output, thus bypassing the blocking diode. (See Figure 4-11.)
- d. With the voltage regulator connected to the array and battery storage, measure the charging voltage on the battery storage at test points B (Figure 2-1). (See Figure 4-4.) If the voltage regulator is supplying the proper charging voltage to the battery storage, the blocking diode is faulty and must be replaced. If

4.2.4 (Contd.)

Test

Action

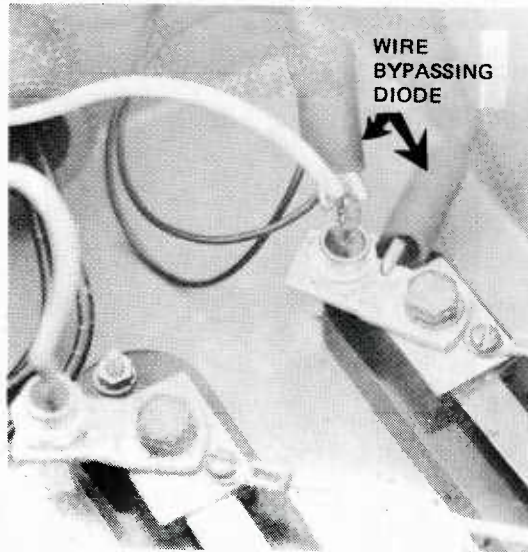

FIGURE 4-11. Bypassing the Blocking Diode.

4. d. (Contd.)

the voltage regulator is not supplying the proper charging voltage, go to Action e.

- e. Check with the voltage regulator manufacturer or manual to determine how to adjust the charging voltage on the battery storage. Adjust the voltage regulator to the proper charging voltage per the manufacturer's instructions. Do not forget to account for the blocking diode voltage drop (0.5 to 1.0 volt). If the proper charging voltage is unavailable or unobtainable, replace the voltage regulator.

4.2.4 (Contd.)

<u>Test</u>	<u>Action</u>
4. (Contd.)	f. After adjusting or replacing the voltage regulator and obtaining the proper charging voltage on the battery storage, remove the wire that short-circuits the blocking diode. If the charging voltage drops by more than the specified diode voltage drop (typically around 1 volt), the blocking diode is bad and must be replaced.
5. A sufficient charging voltage is not available to the battery storage in a nonregulated photovoltaic power system.	<p>a. Disconnect the array from the blocking diode. Measure the array open-circuit voltage (test points E, Figure 2-1) on a clear sunny day. (See Figure 4-10.) If the open-circuit voltage is greater than the required charging voltage plus the blocking-diode voltage drop (0.5 to 1.0 volt), the array is supplying sufficient power to the battery storage. The blocking diode is bad and must be replaced.</p> <p>b. If the array open-circuit voltage is less than the required charging voltage plus the blocking-diode voltage drop (0.5 to 1.0 volt), go to Array Subsystem (4.2.5), Test 1.</p> <p>c. Reconnect the array to the blocking diode, observing the proper polarity.</p>

4.2.5 Array Subsystem

<u>Test</u>	<u>Action</u>
1. The array does not supply adequate voltage.	<ul style="list-style-type: none"> a. Disconnect the array from the voltage regulator or inverter. b. Measure the open-circuit voltage (test points E, Figure 2-1, or test points C, Figure 2-2), measure the module temperature, and count the number of series-connected modules. (See Figure 4-10.) c. Divide the open-circuit voltage by the number of series modules to get the open-circuit voltage per module. d. Make a temperature correction to the manufacturer's characteristic module curve and compare the predicted open-circuit module voltage with the measured open-circuit module voltage. If the voltages are within 10%, the array-string voltage is okay and the array must be redesigned. Contact the Energy Program Office for further assistance. e. If the voltages are not within 10%, disconnect all of the modules in a series string and compare each module's open-circuit voltage with the predicted open-circuit voltage. Each module that does not have an

4.2.5 (Contd.)

<u>Test</u>	<u>Action</u>
1. e. (Contd.)	open circuit voltage within 10% of the predicted open-circuit voltage must be replaced.
2. Array output power has degraded with time.	<p>a. Wash the surface of the array to remove dirt and other foreign matter.</p> <p>b. Remove obstructions that may shadow the array surface (weeds and trees may have grown to where they shadow some portion of the array).</p> <p>c. Disconnect the array from the voltage regulator or inverter.</p> <p>d. Connect test points E (Figure 2-1) or test points C (Figure 2-2) together to short-circuit the array. On a clear day with the sun as perpendicular to the array as possible, measure the array short-circuit current and divide by the number of parallel module strings. If the measured short-circuit current is within 20% of the manufacturer's specified short-circuit current, the array is operating satisfactorily. (See Figure 4-12.)</p> <p>e. If the measured short-circuit current is not within 20% of the manufacturer's specified short-circuit</p>

4.2.5 (Contd.)

Test

Action

ARRAY SHORT
CIRCUIT

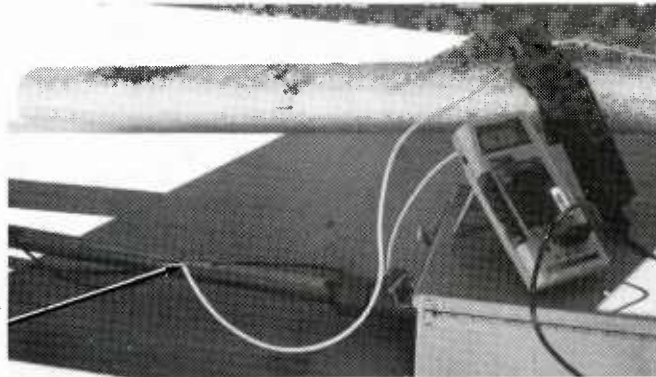

FIGURE 4-12. Measuring the Array Short-Circuit Current.

2. e. (Contd.)

current, isolate each array series string and measure and compare its short-circuit current until the low array series string is isolated.

- f. Separate and measure the short-circuit current of each module in the degraded series string and compare it with the manufacturer's specified short-circuit current until the module with a short-circuit current 20% less than the specified short-circuit current is found.
- g. Replace all degraded modules and rewire and reconnect the array to the voltage regulator or inverter.

4.2.6 Inverter Subsystem

<u>Test</u>	<u>Action</u>
<p>1. The self-commutated inverter output voltage does not equal the rated inverter output voltage.</p>	<p>a. Disconnect the load from the inverter.</p> <p>b. Measure the inverter output voltage. If the measured inverter-output voltage equals the rated output voltage, excessive current is being drawn from the inverter. Go to Test 2.</p> <p>c. If the measured inverter-output voltage does not equal the rated output voltage, go to Test 3.</p>
<p>2. Excessive current is being drawn from the self-commutated inverter.</p>	<p>a. Check the load for internal short circuits. If no short circuits are found, the load is too large for the inverter and must be reduced or removed, or the inverter must be replaced with a larger inverter. Contact the Energy Program Office for assistance.</p> <p>b. If the load has a short circuit, repair the load. The photovoltaic power system is okay.</p>
<p>3. Measured self-commutated inverter output voltage does not equal the rated inverter output voltage.</p>	<p>a. Measure the battery-storage output voltage to the inverter (test points B, Figure 2-1). (See Figure 4-4.)</p> <p>b. If the measured battery-storage output voltage equals the design battery-storage output voltage</p>

4.2.6 (Contd.)

<u>Test</u>	<u>Action</u>
3. b. (Contd.)	<p>(+20%, -5%), the inverter is faulty or improperly designed for the photovoltaic power system and must be replaced. Contact the inverter manufacturer for further assistance.</p> <p>c. If the measured battery-storage output voltage does not equal the design battery-storage output voltage (+20%, -5%), go to Battery-Storage Subsystem (4.2.3), Test 1.</p>
4. Line-commutated inverter will not operate when connected to the utility grid and array.	a. Verify that the inverter is properly designed to operate on the available utility grid voltage and array input voltage. If the inverter is the wrong model for the application, contact the manufacturer for assistance. If the inverter is the proper model for the application, contact the inverter manufacturer for further assistance or consult the inverter installation manual.
5. Self-commutated inverter DC-input circuit breaker trips when inverter is turned on.	a. The DC circuit breaker may trip because the inverter start-up current is too high for the circuit breaker to handle. Connect a 15-ohm, 50-watt resistor in series with a momentary-on switch between the positive "+" battery input terminal

4.2.6 (Contd.)

Test

Action

5. a. (Contd.)

on the inverter and the capacitor side of the inverter circuit breaker. Mount the momentary-on switch on the inverter front panel. The inverter is now started by holding the momentary switch on for a few seconds. This allows a low current (limited by the resistor) to bypass the circuit breaker and slowly charge up the capacitors. Release the momentary switch and turn on the circuit breaker; it should not trip. Contact the Energy Program Office for assistance.

4.3 COMPONENT FAILURE FORM

PPS TITLE _____ DATE _____

LOCATION _____

COMPONENT _____

FAILURE DESCRIPTION _____

CORRECTIVE ACTION TAKEN _____

LENGTH OF DOWNTIME _____

Send completed form to:

Energy Program Office, Code 02A1
Naval Weapons Center
China Lake, California 93555

Appendix A

SELF-STUDY QUESTIONS ON MAINTENANCE
OF PHOTOVOLTAIC POWER SYSTEMS

The following pages contain self-study questions intended to reinforce the user's knowledge of Chapters 1 through 4 of this manual. Answers to the questions are provided on page 62.

SELF-STUDY QUESTIONS - CHAPTER 1

Chapter 1 describes the purpose and content of the "Maintenance of Photovoltaic Power Systems" manual.

Instructions: Select the correct answer(s) for each of the following questions.

- Q 1-1 Both remote stand-alone systems and grid-connected photovoltaic power systems are discussed in this manual.
- a. True
 - b. False
- Q 1-2 This manual is applicable to:
- a. Every detail of a particular design or system
 - b. The general procedures to be used with any design or system
 - c. All of the above.
- Q 1-3 An inspection and maintenance program should be developed to:
- a. Prevent system failures
 - b. Identify potential component failures
 - c. Ensure a safe and adequate system installation
 - d. Repair systems in a timely manner
 - e. All of the above.
- Q 1-4 Visual, mechanical, and electrical inspections need not be performed at regular intervals.
- a. True
 - b. False
- Q 1-5 Preventive maintenance is designed to keep systems operating without unexpected failures.
- a. True
 - b. False

Q 1-6 Corrective maintenance:

- a. Is unscheduled work to repair a system failure
- b. Expands the system capabilities as new requirements arise
- c. Will require fault isolation and component repair
- d. All of the above.

Q 1-7 Photovoltaic power systems:

- a. Produce so little power that electrical safety is of no concern
- b. Cannot be turned off if the sun is shining
- c. Can store lethal amounts of energy and must be worked on with extreme care
- d. All of the above.

SELF-STUDY QUESTIONS - CHAPTER 2

Chapter 2 describes the components and their functions that comprise stand-alone and grid-connected photovoltaic power systems.

Instructions: Select the correct answer(s) for each of the following questions.

- Q 2-1 Photovoltaic power systems supply power that is:
- Reliable
 - Quiet
 - Pollution-free
 - Renewable
 - All of the above.
- Q 2-2 The photovoltaic power system that must be connected to a utility grid to operate properly is:
- A stand-alone system
 - A grid-connected system.
- Q 2-3 A stand-alone system usually contains the following equipment:
- Photovoltaic modules
 - Batteries
 - Line-commutated inverter
 - Voltage regulator
 - Self-commutated inverter.
- Q 2-4 A grid-connected system usually contains the following equipment:
- Photovoltaic modules
 - Batteries
 - Line-commutated inverter
 - Voltage regulator
 - Self-commutated inverter.
- Q 2-5 A photovoltaic cell:
- Uses sunlight to heat water
 - Stores electrical energy for use at night
 - Converts sunlight to electricity
 - All of the above.

- Q 2-6 A photovoltaic module:
- a. Contains only one photovoltaic cell
 - b. Protects the cells from the environment
 - c. Makes handling of photovoltaic cells easier
 - d. Uses sunlight to heat water.
- Q 2-7 A diode allows current to flow in both directions.
- a. True
 - b. False
- Q 2-8 A storage battery:
- a. Stores energy for use at night and on cloudy days
 - b. Must have a low self-discharge
 - c. Need not survive a number of discharge/recharge cycles
 - d. Must require little maintenance.
- Q 2-9 The battery-storage output voltage can be increased by connecting storage batteries:
- a. In series
 - b. In parallel.
- Q 2-10 A voltage regulator:
- a. Adjusts battery-charging voltage to maximize battery charging
 - b. Adjusts battery water level
 - c. Prevents battery water loss
 - d. All of the above.
- Q 2-11 A self-commutated inverter:
- a. Must be connected to a utility grid to operate properly
 - b. Converts DC power to AC power
 - c. Should not be connected to a utility grid
 - d. Converts AC power to DC power.
- Q 2-12 A line-commutated inverter:
- a. Must be connected to a utility grid to operate properly
 - b. Converts AC power to DC power
 - c. Usually has an isolation transformer connected between it and the utility grid
 - d. Is used in remote applications away from the utility grid.

SELF-STUDY QUESTIONS - CHAPTER 3

Chapter 3 discusses the routine maintenance requirements of photovoltaic power systems and their components.

Instructions: Select the correct answer(s) for each of the following questions.

- Q 3-1 The photovoltaic modules should be checked:
- a. Every month
 - b. Every 6 months
 - c. Every year
 - d. Never.
- Q 3-2 Photovoltaic modules should be checked for:
- a. Cracked surfaces
 - b. Physical size
 - c. Tilt angle
 - d. Delamination.
- Q 3-3 It is advisable to wash photovoltaic modules in the afternoon sun.
- a. True
 - b. False
- Q 3-4 A visual inspection should be conducted every 6 months on the:
- a. Photovoltaic modules
 - b. Battery storage
 - c. Electrical and support material
 - d. Electronic and power-conditioning equipment
 - e. All of the above.
- Q 3-5 When working with a battery-storage system:
- a. No caution is necessary
 - b. Little caution is necessary
 - c. Moderate caution is necessary
 - d. Extreme caution is necessary

- Q 3-6 The aspects of a battery storage system that require caution are:
- a. Explosive gases
 - b. Sulfuric-acid fumes and spills
 - c. Physical battery weight
 - d. High voltages and current
 - e. All of the above.
- Q 3-7 The following material is used in battery-storage maintenance:
- a. Baking soda and brush
 - b. Paint, hammer, and nails
 - c. Vaseline or other battery grease
 - d. Pure distilled water and hydrometer
 - e. Voltmeter
 - f. All of the above.
- Q 3-8 A "PPS Preventive Maintenance" worksheet should be completed for each photovoltaic power system every 6 months.
- a. True
 - b. False

SELF-STUDY QUESTIONS - CHAPTER 4

Chapter 4 is a troubleshooting guide that will enable the user to identify equipment faults and in most cases correct inoperable photovoltaic power systems.

Instructions: Select the correct answer(s) for each of the following questions.

Q 4-1 If the photovoltaic power system does not operate properly after a fault has been identified and corrected:

- a. Give up
- b. Go through the troubleshooting procedure again
- c. The system is not repairable
- d. Contact the Energy Program Office.

Q 4-2 through Q 4-6 refer to Figure A-1.

Q 4-2 The self-commutated inverter does not work. The problem is:

- a. The battery voltage is too high
- b. The inverter input polarity is wrong
- c. The voltage regulator is miswired
- d. None of the above.

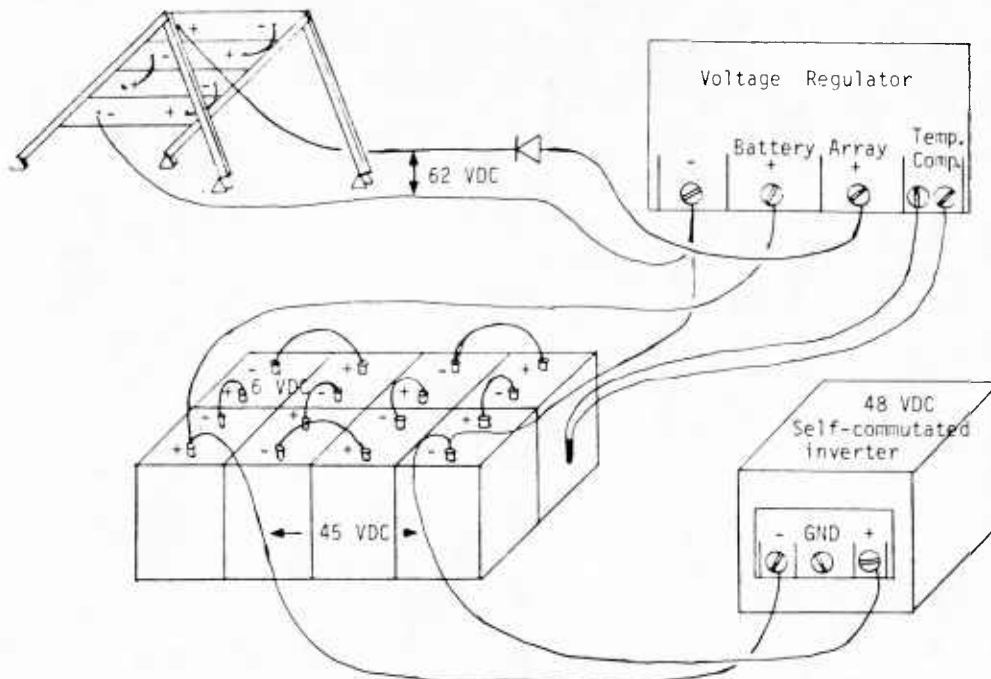

FIGURE A-1. Diagram to be Used for Self-Study Questions 4-2 through 4-6.

- Q 4-3 The battery storage voltage measures 45 volts and the load is operating properly. The problem is:
- The batteries are miswired
 - The photovoltaic array is too small
 - The blocking diode is installed backwards
 - The voltage regulator is miswired.
- Q 4-4 The battery charging voltage is 60 volts. The problem may be:
- The inverter is drawing too much power
 - The battery storage is miswired
 - The temperature-compensating probe is improperly located
 - The voltage regulator is miswired.
- Q 4-5 The voltage at test points E equals:
- 62
 - 48
 - 6
 - 45
- Q 4-6 The voltage at test points A equals:
- 62
 - 48
 - 6
 - 45
- Q 4-7 The isolation transformer does not hum. The probable cause is:
- The photovoltaic array is not supplying power
 - The utility circuit breaker is not on
 - The DC input fuse is missing or blown
 - The line-commutated inverter is faulty.
- Q 4-8 A storage battery has a specific gravity 20% lower than the average specific gravity. The troubleshooting procedure that would expose this problem is:
- Stand-alone photovoltaic power system test 2a
 - Battery storage subsystem test 5c
 - Battery storage subsystem test 4d
 - Voltage regulator subsystem test 4a.

ANSWERS TO SELF-STUDY QUESTIONS

Chapter 1	Q 1-1	a
	Q 1-2	b
	Q 1-3	a, b, and d
	Q 1-4	b
	Q 1-5	a
	Q 1-6	a and c
	Q 1-7	b and c
Chapter 2	Q 2-1	e
	Q 2-2	b
	Q 2-3	a, b, d, and e
	Q 2-4	a and c
	Q 2-5	c
	Q 2-6	b and c
	Q 2-7	b
	Q 2-8	a, b, and d
	Q 2-9	a
	Q 2-10	a and c
	Q 2-11	b and c
	Q 2-12	a and c
Chapter 3	Q 3-1	b
	Q 3-2	a and d
	Q 3-3	b
	Q 3-4	e
	Q 3-5	d
	Q 3-6	e
	Q 3-7	a, c, d, and e
	Q 3-8	a
Chapter 4	Q 4-1	b and d
	Q 4-2	b
	Q 4-3	c
	Q 4-4	c
	Q 4-5	a
	Q 4-6	d
	Q 4-7	b
	Q 4-8	b

NWC TP 6563

Corrective maintenance . . . 1.3.3, 4.1
Corrosion 3.4, 3.5, 3.5.2
Cracked surfaces 3.2
Current 2.4.1, 2.4.3, 2.4.4, 2.4.6, 4.2.3, 4.2.6
Cutoff voltage 4.2.4

D

DC power 2.1, 2.4.1, 4.2.6
Degradation 1.3.3, 3.2, 4.2.5
Delamination 3.2
Detergent 3.2
Diodes 2.4.4, 3.3, Figure 2-8
Discharge 2.4.6, 2.4.8, 4.2.4
Disconnect 2.4.3
Dissimilar metals 2.4.5
Distilled water 3.5.3
Downtime 4.3

E

Electrical
 Connections 2.4.2
 Contacts 2.4.1
 Enclosure 2.4.3
 Material 2.4.3, 3.3
 Subsystem 3.3, 3.7
Electrolyte 3.5, 3.5.1, 3.5.2, 3.5.3, 3.7, Figure 4-6
Electronics 3.6, 3.7
Encapsulant 2.4.2, Figure 2-7
Energy 2.4.1, 2.4.6
Energy Program Office 4.1, 4.3
Environment 2.4.2

F

Failure description 4.3
Failures 1.3, 1.3.2, 1.3.3
Fault 4.1, 4.2
Field repair 1.2, 4.1
Frequency 2.4.9, 2.4.10
Fuse 2.4.3

G

Galvanic corrosion 2.4.5
Gases 3.5.1
Grid-connected PPS 2.3, 2.4, 4.2.2, Figure 4-3

H

Hydrometer 3.5.3, Figure 4-6

I

Identification 1.2, 4.1
 Inefficiency 2.4.6
 Input 2.4.7
 Inspection 1.3, 1.3.1, 1.3.2
 Insulation 3.3, 3.5.1
 Inversion 2.4.10
 Inverter 2.2, 2.3, 2.4.9, 2.4.10, 2.4.11, 4.2.6,
 Figure 2-12, Figure 2-13
 Subsystem 4.1, 4.2.6, Figure 2-1, Figure 2-2
 I_{sc} 2.4.1
 Isolating failures 1.2, 4.1
 Isolation transformer 2.4.11, 3.6, 4.2.2, Figure 2-14

L

Laminate 2.4.2
 Lead-acid battery 2.4.6
 Leak 3.5.2
 Line-commutated
 inverter 2.3, 2.4.10, 2.4.11, 3.6, 4.2.6, Figure 2-13
 Load 2.1, 2.2, 2.4.6, 2.4.9, 4.2.1, 4.2.2,
 Figure 4-2
 Low-voltage cutoff 2.4.8, 3.6, 4.2.3, 4.2.4

M

Maintenance
 Checklist 1.3, 3.7
 Program 1.3
 Material 2.4.5
 Maximum power point 2.4.1, Figure 2-4, Figure 2-5
 Medical attention 3.5.1
 Metal structure 2.4.5
 Module 2.4, 2.4.2, 2.4.4, 3.2, 3.7, Figure 2-7

N

National Electrical Code 2.4.3
 Neutralizing acid 3.5.1
 Normally open relay 2.4.10

O

Obstructions 4.2.5
 Open-circuit voltage 2.4.1, 4.2.4, 4.2.5, 4.2.6, Figure 2-4,
 Figure 2-5, Figure 4-10
 Outgassing 2.4.7
 Output 2.4.2, 2.4.7, 2.4.9, 4.2.5, 4.2.6
 Overcharging 2.4.7

P

Paint 2.4.5
 Phase 2.4.9
 Photon 2.4.1, Figure 2-3
 Photovoltaic cells 2.4.1, 2.4.2, Figure 2-3
 Photovoltaic power system . 2.1, 2.2, 2.3, 2.4, 2.4.2, Figure 2-1,
 Figure 2-2
 Plug 2.4.3
 PN junction 2.4.1, Figure 2-3
 Polarity 4.2.1
 Power 2.4.4, 2.4.6, 2.4.9, 2.4.10, 4.2.2
 Conditioning 3.6, 3.7
 Loss 4.2.1, 4.2.2
 Quality 2.4.9, 2.4.10
 Preventive maintenance . . . 1.3.2, 4.2

R

Rain 3.4
 Recharging 2.4.6
 Relays 2.4.3, 2.4.10, 3.3
 Reliability 2.4.4
 Requirements 2.4.7, 2.4.9, 3.1
 Rotting 3.4
 Routine maintenance 3.1
 Rust 2.4.5

S

Safety 1.4, 2.4.10, 3.5.1
 Scheduled maintenance . . . 3.1
 Self-commutated inverter . . 2.4.9, 3.6, 4.2.6, Figure 2-13
 Self-discharge 2.4.6
 Semiconductor 2.4.1
 Series connection 2.4.1, 2.4.2, 2.4.4, 2.4.6, Figure 2-6,
 Figure 2-10
 Shock 3.5.1
 Short circuit 2.4.11

NWC TP 6563

Short-circuit current . . . 2.4.1, 4.2.5, Figure 2-4, Figure 2-5,
Figure 4-12
Signal 2.4.9, 2.4.10
Socket 2.4.3
Solar cell 2.4.1, 2.4.2, Figure 2-3
Solar radiation 2.4.1
Solid-state devices 2.4.4, 2.4.9, 2.4.10
Specific gravity 4.2.3, Figure 4-6
Stand-alone PPS 2.2, 2.4, 4.2.1
Standard test
 conditions 2.4.1
Steel structures 2.4.5
Structural failure 3.2
Structural member 3.4
Substrate 2.4.2, Figure 2-7
Subsystem 4.1, 4.2, Figure 2-1, Figure 2-2
Suggestions 1.5
Sulfuric acid 3.5.1
Summary 3.1
Superstrate 2.4.2, Figure 2-7
Support structure 2.4.5, 3.4, 3.7
Switches 2.4.3, 3.3
System design 1.2
System performance 1.3.3

T

Technician 1.2
Temperature 2.4.1, 2.4.2, 2.4.6, 2.4.7
Temperature-compensation . . 4.2.4, Figure 4-8
Terminals 2.4.1, 2.4.2, 2.4.3, 3.5, 3.5.2, 3.5.4, 3.7
Thermal shock 3.2
Troubleshooting guide . . . 1.3.3, 4.1, 4.2, Figure 4-1

U

Utility grid 2.2, 2.3, 2.4.10, 2.4.11, 4.2.2, 4.2.6,
Figure 4-3

V

Vaseline 3.5.2
Visual inspection 3.2, 3.3, 3.4, 3.5, 3.6, 3.7
 V_{oc} 2.4.1
Voltage 2.4.1, 2.4.2, 2.4.4, 2.4.6, 2.4.7, 2.4.9,
2.4.10, 2.4.11, 3.5.1, 3.5.4, 4.2.5
 Regulator 2.4, 2.4.7, 3.6, 4.2.3, 4.2.4, Figure 2-11,
Figure 4-7, Figure 4-9
 Subsystem 4.1, 4.2.4, Figure 2-1

W

Water loss 2.4.7
Wear 3.3
Wind 3.2
Wire 2.4.3, 3.5.2, 3.6
Wooden structures 2.4.5

NWC TP 6563

SUGGESTION FORM

Date: _____

Suggestor's Name: _____

Address: _____

Phone Number: _____

Suggestion References

Chapter: _____

Section: _____

Problem Encountered:

Solution Suggested:

Comments:

Send to: Energy Program Office, Code 02A1
Naval Weapons Center
China Lake, California 93555

INITIAL DISTRIBUTION

- 7 Naval Air Systems Command
 - AIR-610 (1)
 - AIR-6103E (3)
 - AIR-6301A1 (1)
 - AIR-7226 (2)
- 2 Deputy Chief of Naval Operations (Logistics)
 - OP-413F (1)
 - OP-431 (1)
- 3 Chief of Naval Material
 - MAT-05, B. Abrahms (1)
 - MAT-08E (1)
 - MAT-08E3 (1)
- 12 Naval Facilities Engineering Command, Alexandria
 - FAC-03 (1)
 - FAC-03E (1)
 - FAC-044 (1)
 - FAC-0441 (1)
 - FAC-08T (1)
 - FAC-11 (1)
 - FAC-111 (1)
 - FAC-111B (1)
 - FAC-111Z (1)
 - FAC-111ZE (1)
 - FAC-1113 (1)
 - FAC-1113D (1)
- 1 Naval Facilities Engineering Command, Atlantic Division (Code 111)
- 1 Naval Facilities Engineering Command, Chesapeake Division (Code 112)
- 1 Naval Facilities Engineering Command, Northern Division, Philadelphia (Code 111/JZ)
- 3 Naval Facilities Engineering Command, Pacific Division
 - Code 11 (2)
 - Code 404 (1)
- 2 Naval Facilities Engineering Command, Southern Division, Charleston
 - Code 111 (1)
 - Code 1028 (1)
- 3 Naval Facilities Engineering Command, Western Division, San Bruno
 - Code 111 (1)
 - Code 1112 (2)
- 2 Naval Sea Systems Command (SEA-09B312)
 - 1 Assistant Secretary of the Navy (Research, Engineering and Systems)
 - 1 Commander in Chief, U.S. Pacific Fleet (Code 325)
 - 1 Commander, Third Fleet, Pearl Harbor
 - 1 Commander, Seventh Fleet, San Francisco
- 2 Marine Corps Air-Ground Combat Center, Twenty-Nine Palms (Alpha Company, Headquarters Battalion, INL Division, Col. R. G. Ponsford)
- 1 Marine Corps Air Station, El Toro (Public Works Department)
- 1 Marine Corps Base, Camp Pendleton (Public Works Officer)
- 3 Naval Academy, Annapolis
 - Director of Research (2)
 - Library (1)

U217008

- 1 Naval Activities, Spain
- 20 Naval Civil Engineering Laboratory, Port Hueneme
 - Code L01 (1)
 - Code L03 (1)
 - Code L03AE (12)
 - Code L60 (1)
 - Code L62 (1)
 - Code L63 (4)
- 1 Naval Coastal Systems Center, Panama City (Code 3210)
- 2 Naval Energy and Environmental Support Activity, Port Hueneme
 - Code 11 (1)
 - Code 111 (1)
- 1 Naval Ordnance Station, Indian Head (Code SCE3)
- 1 Naval Postgraduate School, Monterey
- 1 Naval Research Laboratory
- 1 Naval Research Laboratory, Chesapeake Bay Detachment, Chesapeake Beach (Code 2730)
- 3 Naval Ship Weapon Systems Engineering Station, Port Hueneme
 - Code 5711, Repository (2)
 - Code 5712 (1)
- 1 Naval Underwater Systems Center Detachment (Tudor Hill), Bermuda
- 1 Naval War College, Newport
- 1 Navy Public Works Center, San Diego (Code 613)
- 1 Air Force Intelligence Service, Bolling Air Force Base (AFIS/INTAW, Maj. R. Lecklider)
- 1 Deputy Assistant Secretary of Defense (Energy, Environment and Safety)
- 1 Deputy Assistant Secretary of Defense (Installations and Housing)
- 12 Defense Technical Information Center
- 1 Department of Energy (Photovoltaics Division)
- 1 Brigham Young University, Provo, UT (Mechanical Engineering Department)
- 1 California Institute of Technology, Jet Propulsion Laboratory, Pasadena, CA