

AD-A152 370

THE R-689 RADIO SET(U) FOREIGN TECHNOLOGY DIV
WRIGHT-PATTERSON AFB OH 5 RONZHIN 19 FEB 85
FTD-ID(RS)T-0543-84

1/1

UNCLASSIFIED

F/G 17/2.1 NL



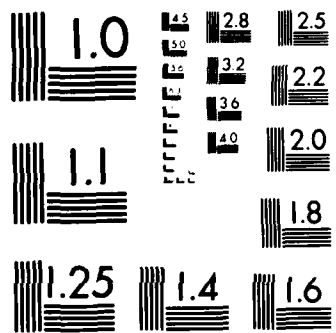

MICROCOPY RESOLUTION TEST CHART
NATIONAL BUREAU OF STANDARDS 1963-A

2

FTD-ID(RS)T-0543-84

FOREIGN TECHNOLOGY DIVISION



THE R-609 RADIO SET

by

S. Ronzhin

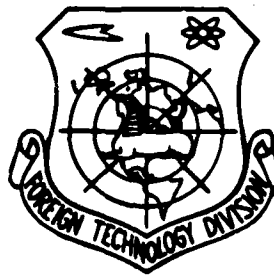

DTIC
ELECTE
APR 15 1985

S D

Approved for public release;
distribution unlimited.

AD-A152 370

DTIC FILE COPY



EDITED TRANSLATION

FTD-ID(RS)T-0543-84

19 February 1985

MICROFICHE NR: FTD-84-C-000071

THE R-609 RADIO SET

By: S. Ronzhin

English pages: 9

Source: Radio, Nr. 9, 1971, pp. 14-16; 1 unnr

Country of origin: USSR

Translated by: Charles T. Ostertag, Jr.

Requester: RCA

Approved for public release; distribution unlimited.

Accession For	
NTIS GRA&I	<input checked="" type="checkbox"/>
DTIC TAB	<input type="checkbox"/>
Unannounced	<input type="checkbox"/>
Justification	
By _____	
Distribution/	
Availability Codes	
Dist	Avail and/or Special
A-1	

THIS TRANSLATION IS A RENDITION OF THE ORIGINAL FOREIGN TEXT WITHOUT ANY ANALYTICAL OR EDITORIAL COMMENT. STATEMENTS OR THEORIES ADVOCATED OR IMPLIED ARE THOSE OF THE SOURCE AND DO NOT NECESSARILY REFLECT THE POSITION OR OPINION OF THE FOREIGN TECHNOLOGY DIVISION.

PREPARED BY:
TRANSLATION DIVISION
FOREIGN TECHNOLOGY DIVISION
WP-AFB, OHIO.



U. S. BOARD ON GEOGRAPHIC NAMES TRANSLITERATION SYSTEM

Block	Italic	Transliteration	Block	Italic	Transliteration
А а	<i>А а</i>	A, a	Р р	<i>Р р</i>	R, r
Б б	<i>Б б</i>	B, b	С с	<i>С с</i>	S, s
В в	<i>В в</i>	V, v	Т т	<i>Т т</i>	T, t
Г г	<i>Г г</i>	G, g	У у	<i>У у</i>	U, u
Д д	<i>Д д</i>	D, d	Ф ф	<i>Ф ф</i>	F, f
Е е	<i>Е е</i>	Ye, ye; E, e*	Х х	<i>Х х</i>	Kh, kh
Ж ж	<i>Ж ж</i>	Zh, zh	Ц ц	<i>Ц ц</i>	Ts, ts
З з	<i>З з</i>	Z, z	Ч ч	<i>Ч ч</i>	Ch, ch
И и	<i>И и</i>	I, i	Ш ш	<i>Ш ш</i>	Sh, sh
Й й	<i>Й й</i>	Y, y	Щ щ	<i>Щ щ</i>	Shch, shch
К к	<i>К к</i>	K, k	Ъ ъ	<i>Ъ ъ</i>	"
Л л	<i>Л л</i>	L, l	Ы ы	<i>Ы ы</i>	Y, y
М м	<i>М м</i>	M, m	Ь ь	<i>Ь ь</i>	'
Н н	<i>Н н</i>	N, n	Э э	<i>Э э</i>	E, e
О о	<i>О о</i>	O, o	Ю ю	<i>Ю ю</i>	Yu, yu
П п	<i>П п</i>	P, p	Я я	<i>Я я</i>	Ya, ya

*ye initially, after vowels, and after ъ, ь; e elsewhere.
When written as ë in Russian, transliterate as yë or ë.

RUSSIAN AND ENGLISH TRIGONOMETRIC FUNCTIONS

Russian	English	Russian	English	Russian	English
sin	sin	sh	sinh	arc sh	sinh ⁻¹
cos	cos	ch	cosh	arc ch	cosh ⁻¹
tg	tan	th	tanh	arc th	tanh ⁻¹
ctg	cot	cth	coth	arc cth	coth ⁻¹
sec	sec	sch	sech	arc sch	sech ⁻¹
cosec	csc	csch	csch	arc csch	csch ⁻¹

Russian English

rot curl
lg log

GRAPHICS DISCLAIMER

All figures, graphics, tables, equations, etc. merged into this translation were extracted from the best quality copy available.

THE R-609 RADIO SET

S. Ronzhin

The R-609 radio set is intended for simplex telephone communication in the frequency range from 100 to 150 MHz with the setting of the operating frequencies of the transmitter and receiver by interchangeable crystals. The set can be preliminarily tuned in this range on any four operating frequencies and search-free communication carried out on them. Switching from one communication channel to another is realized automatically by pressing the appropriate button on the control panel or on the measuring unit, for which no more than three seconds are required.

Thirty crystals each for the transmitter and the receiver are usually attached to the operating set of the station.

The radio set utilizes a wide-band discone antenna, ensuring communication in the entire range of frequencies, or a half-wave vibrator.

The radio set is powered from an alternating current network with a voltage of 110, 127 or 220 V, and also from an on-board direct current network through a voltage converter of the types OP-120 and AMG-3.

The operating complex of the radio set includes five main units: unit A - transmitter, unit B - receiver, unit V - rectifier, unit PU - control unit, and unit I - measuring unit. The units are connected together by special cables. The external view and the layout for connecting the units are shown on the first page of the insert.

The R-609 radio set is used for communication mainly in the navy, and its analogous radio sets - the RSIU-3M, R-800, R-811 and R-812 - in aviation.

The transmitter of the R-609 radio set contains a four-stage hf amplifier with an eighteen-fold gain of frequency of the master oscillator, a power amplifier and a modulator. The block diagram of the transmitter is shown in Figure 1.

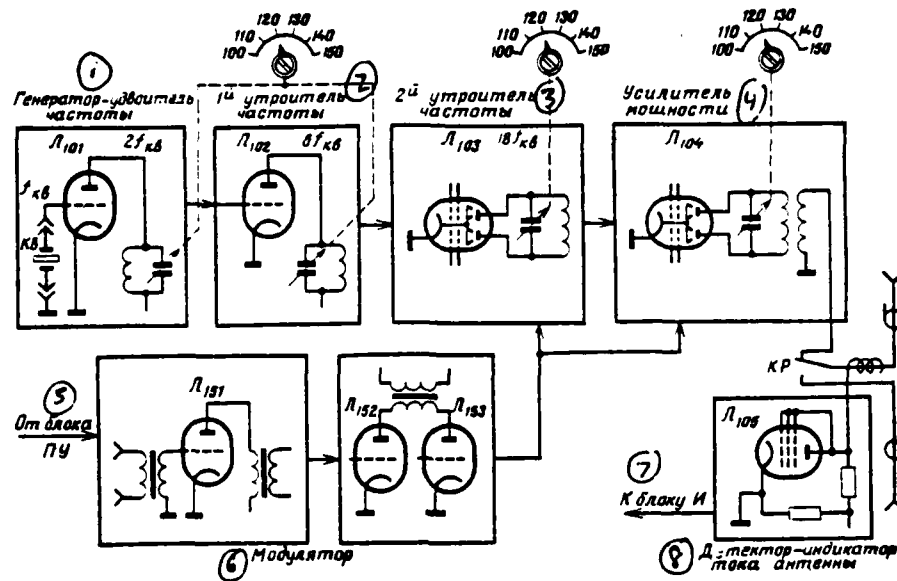

Figure 1.

Key: (1) Frequency oscillator-doubler; (2) 1st frequency tripler; (3) 2nd frequency tripler; (4) Power amplifier; (5) From PU unit; (6) Modulator; (7) To I unit; (8) Detector-indicator of antenna current.

In the master oscillator, being simultaneously a frequency doubler, tube L₁₀₁ (6P6S) functions. The frequency of the master oscillator is determined by the interchangeable crystal K_v, included in the circuit of the control grid of the tube and operating on the first harmonic (frequencies of the first harmonic of the crystals can be from 5555.55 to 8333.33 kHz). In the anode circuit of the oscillator tube voltage with the frequency of the second harmonic of the included crystal ($2f_{kv}$) is separated out. It arrives at the input of the second stage of the transmitter.

The second stage on tube L₁₀₂ (6P6S) functions as a frequency tripler; in the anode circuit of the tube of this stage voltage with a frequency equal to $6f_{kv}$ is separated out.

The third stage on tube L₁₀₃ (GU-32), included in a two-cycle arrangement of voltage gain, is the second frequency tripler ($18f_{KV}$), and the fourth, output stage on tube L₁₀₄ (GU-32) - a two-cycle power amplifier.

The output power of the transmitter is around 6 W.

Tuning of the transmitter is realized with capacitors of variable capacitance. The capacitors of the anode circuit, the master oscillator-frequency doubler and the first frequency tripler are consolidated in the unit; the capacitors of variable capacitance of the circuits of the second frequency tripler and the power amplifier are separate.

Amplitude modulation is used in the transmitter. It is realized over the anode circuit and the screen grid of the power amplifier and over the circuit of the screen grid of the second frequency tripler.

The modulator, mounted together with the transmitter, is a two-stage 1f amplifier. Its first stage on tube L₁₅₁ (6G2) functions as a preliminary amplifier of voltage which arrives at it from the carbon microphone of the MRU type through the control panel or from the line of the remote communication post (VPS); the second stage on tubes L₁₅₂ and L₁₅₃, included in a two-cycle arrangement, is the output stage of the modulator.

For control of current in the output circuit of the transmitter tube L₁₀₅ (6Zh3P) is used. It is connected with the antenna through a current transformer and functions as a rectifier. The current rectified by the tube is fed to the measuring unit, where it induces the corresponding deflection of the needle of the indicator device.

The receiver of the radio set (see the block diagram in Fig. 2) is an eleven-tube superheterodyne with double conversion of frequency. The sensitivity of the receiver over the entire range of frequencies is no worse than 10 μ V.

The double conversion of frequency of the signal which is received in the case of one heterodyne is a characteristic feature of the receiver of the R-609 radio set. This provides the receiver with a high degree of sensitivity, stability of operation and satisfactory attenuation of interference on the mirror channel.

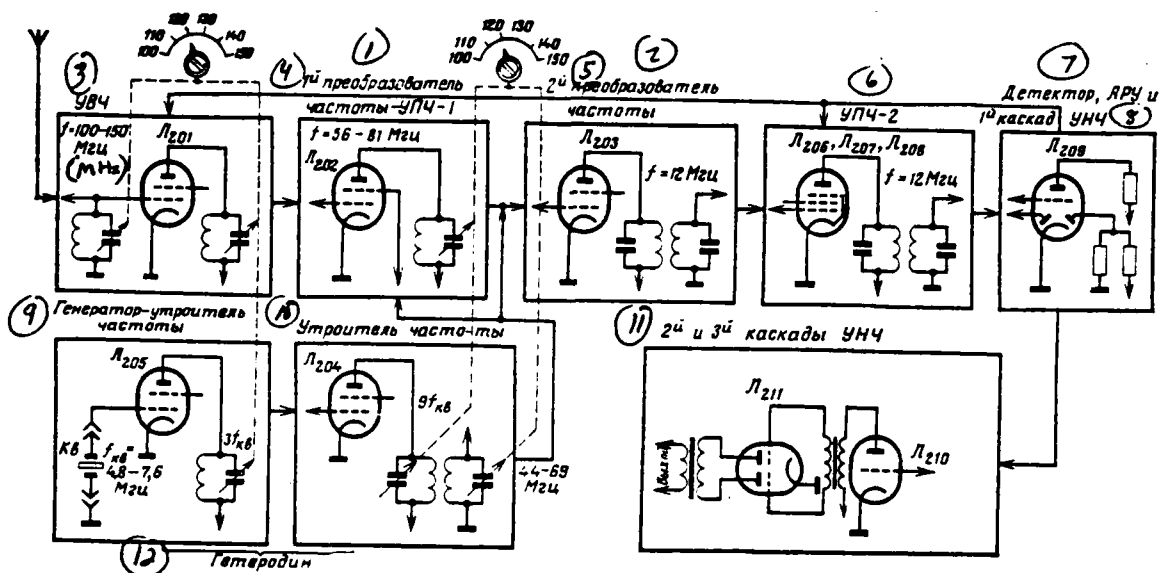

Figure 2.

Key: (1) (4) 1st frequency converter - UPCh-1 [if amplifier]; (2) (5) 2nd frequency converter; (3) UVCh [hf amplifier]; (6) UPCh-2; (7) Детектор, АРУ [automatic gain control], and 1st stage of the UNCh [lf amplifier]; (9) Oscillator-frequency tripler; (10) Frequency tripler; (11) 2nd and 3rd stages of the UNCh; (12) Heterodyne.

Tubes L205 and L204 (6Zh3P) function in the heterodyne of the receiver. Crystal Kv with a resonance frequency of $4888.88 - 7666.66 \text{ kHz}$ is included in the control grid of tube L205. The anode circuit of the tube separates out the voltage with a frequency of the third harmonic of the crystal ($3f_{kv}$), which arrives at the control grid of tube L204 of the frequency tripling stage.

In the anode circuit of tube L204 oscillation voltage of the ninth harmonic of the crystal ($9f_{kv}$) is separated out. It corresponds to a frequency range of $44 - 69 \text{ MHz}$. This voltage enters the screen grid of tube L202 (6Zh3P) of the first frequency converter. Arriving at the control grid of this same tube is the signal from the radio set which is being received, operating in the frequency range of $100 - 150 \text{ MHz}$, and preamplified by the stage of the UVCh on tube L201 (6Zh3P). The interaction of the two voltages with different frequencies on the grids of tube L202 creates in its anode circuit

oscillations of intermediate frequency, which depending on the frequency of the signal which is received can be within the limits of 56-81 MHz. Thus the first frequency converter is simultaneously the first if amplifier (UPCh-1).

The voltage of intermediate frequency, separated out by the anode circuit of tube L₂₀₂, enters the control grid of tube L₂₀₃ (6Zh3P) of the second frequency converter. The voltage from the heterodyne enters this same grid of tube L₂₀₃. As a result, in the anode circuit of the tube of this stage hf voltage of the second intermediate frequency, equal to 12 MHz, is created. It is amplified by the three-stage if amplifier (UPCh-2) on tubes L₂₀₆-L₂₀₈ (6K4), then detected by tube L₂₀₉ (6G2), and the detected signal is amplified by the three-stage lf amplifier on tubes L₂₀₉ (6G2), L₂₁₀ (6P6S) and L₂₁₁ (6N7). Tuning of the oscillatory circuits of the receiver is done by two units of capacitors of variable capacitance.

The power supply unit provides: alternating voltage of 27 V - for power supply of the filaments of receiver and transmitter tubes; dc voltage of 27 V - for power supply of electromagnetic relays and other circuits of automatic devices; dc voltages of 315 and 180 V - for power supply of anode-screen circuits of the transmitter and receiver; dc voltage of 105 V - for power supply of the bias circuits of the tubes.

The rectifiers of the power supply unit are assembled in a bridge arrangement on selenium stacks.

The control panel is mounted in a metal box with an inclined front panel, on which there are: a plug for hooking up a microphone of the MRU type, jacks for TA-4 headsets, six switching knobs, six buttons and three signal lamps. With the help of these control elements it is possible to turn on the power supply for the radio set, switch it from receive to transmit, from one communication channel to another, to carry out communications with the VPS without going out into the air, to transfer control of the station to VPS posts. Switching of the station from reception to transmission and back is done by pressing the microphone push-to-talk key.

From the VPS it is possible to conduct telephone conversations with the duty operator of the station or to receive or transmit through the radio set. Operation of the radio set on the VPS is

indicated by signal lamps.

The measuring unit makes it possible to measure: voltages of the circuits of the filament, the anodes and the bias of the tubes of the receiver and transmitter; overall current consumed by the receiver; anode currents of the tubes of the frequency triplers and the output stage, current in the antenna circuit and overall current of the transmitter.

This unit can be used as a voltmeter or a tester. From it it is possible to control the radio set, to receive or transmit and to switch the station from one communication channel to another. Practically all these manipulations are done during tuning of the station, and during operation it is usually disconnected from the station and closed down.

Switching of the station from one communication channel to another is done automatically with the help of a special channel switching mechanism. In the working state this mechanism is rigidly connected with the shafts of the units of capacitors of variable capacitances with the help of locks, located above on the tuning knobs. If the locks are turned one turn counter clockwise, then the switching mechanism will be disconnected from the shafts of the capacitors and they can be turned by hand. It is permitted to lock and unlock the tuning knobs of the radio set only after pressing the button "Reset."

Preparation of the radio set for operation and tuning it.

The radio operator who is servicing the station should first of all connect all the units with the appropriate cables (see insert), tighten their plug and socket units securely, hook up the set to a source of power, and, having removed the covers from the tuning mechanisms of the receiver and transmitter, insert into jacks 1 and 2, 3 and 4 the crystals which correspond to the assigned operating frequencies.

The crystals of the transmitter are designated with the letter A, and the crystals of the receiver - with the letter B. The frequencies of the crystals are engraved on their housings in megahertz.

It is also possible to use crystals from other analogous radio sets, on the housings of which the conditional numbers from

1 to 601 are indicated. In this case the operating frequency of the station is determined using the formula:

$$f, \text{ MHz} = \frac{N_{\text{ks}} - 1}{12} + 100.$$

Key: (1) MHz.

Further, having connected the cables of the measuring unit with the F-101 and F-106 plugs of the transmitter, it is necessary, on the control panel, to turn on the power supply, on the receiver and transmitter to press the buttons "Reset" in order to unlock their tuning knobs, and with the help of the instrument and switch on the measuring unit to check the voltages of the filament, the anode and the bias of the receiver and transmitter. Then set the switch of the measuring unit in the position "Tripler," press the button "1" of the communication channel, move the toggle switch "Pr-Per" (receive-transmit) to the position "Per" and, turning the first tuning knob on the transmitter to the left, achieve the maximum deflection of the needle of the instrument. In this case the indicator of the tuning knob should coincide with that frequency on the scale which is indicated on the crystal. This compulsory condition also pertains to the tuning of other stages of the radio set.

After this place the switch of the instrument of the measuring unit in the position "Transmitter output" and carry out tuning with the second knob based on the maximum reading of the instrument. When the switch of the instrument is switched to the position "Antenna" the transmitter is tuned with the third knob, also achieving the maximum reading of the instrument.

Now the tuning of the transmitter on the first communication channel is concluded. On the other communication channels the tuning of the transmitter is done in the same sequence, but switching from one communication channel to another with the tuning knobs unlocked can be done only in the order of numbering of the communication channels: 1, 2, 3 and 4. If the channels are switched in a different order the tuning will be out of alignment.

After tuning of the transmitter on the 4th communication channel it is necessary to press the button "Reset," in turn lock all three tuning knobs, and then again check the tuning of all the communication channels based on the deflection of the instrument needle when

measuring the antenna current. If it turns out that the tuning on some channel is out of alignment, then it is necessary to unlock the knobs and repeat the tuning.

Having completed the tuning of the transmitter, place the toggle switch "Pr-Per" in the position "Pr," disconnect the cables of the instrument from the transmitter and hook them up to plugs F-201 and F-204 of the receiver. Now it is necessary to set the switch of the instrument in the position "Crystal pr" [Kvarts pr] (receiver crystal), move the sensitivity regulator to the mark "10," press the button of the communication channel "1" and, turning the left tuning knob of the receiver along the corresponding frequency on the scale, achieve the maximum reading of the instrument. With the second knob the receiver is tuned based on the maximum level of noises in the telephones.

In the same manner the receiver is tuned on the remaining communication channels. When the 4th communication channel is tuned press the button "Reset" and lock the tuning knobs.

After checking the tuning of the receiver on all the communication channels disconnect the instrument of the measuring unit from the receiver, thus concluding the preparation of the radio set for operation.

END

FILMED

5-85

DTIC