

AD-A152 662

PRESSURIZED CRYSTALLIZATION OF ALUMINUM ALLOY AA 5086
(U) NAVAL SURFACE WEAPONS CENTER SILVER SPRING MD
H DEJARNETTE ET AL. 04 JAN 84 NSWC/TR-83-492

1/1

UNCLASSIFIED

F/G 11/6

NL

	END												
	FILMED												
	DTIC												

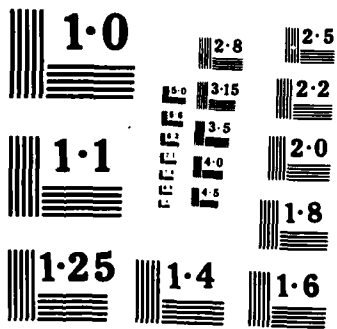

(2)

NSWC TR 83-492

AD-A152 662

PRESSURIZED CRYSTALLIZATION OF ALUMINUM ALLOY AA 5086

BY H. DeJARNETTE A. DIVECHA S. KARMARKAR W. WILLARD
RESEARCH AND TECHNOLOGY DEPARTMENT

4 JANUARY 1984

Approved for public release, distribution unlimited

DTIC
ELECTE
APR 22 1985
S D
B

DTIC FILE COPY



NAVAL SURFACE WEAPONS CENTER

Dahlgren, Virginia 22448 • Silver Spring, Maryland 20910

85 03 29 017

UNCLASSIFIED

SECURITY CLASSIFICATION OF THIS PAGE (When Data Entered)

REPORT DOCUMENTATION PAGE		READ INSTRUCTIONS BEFORE COMPLETING FORM
1. REPORT NUMBER NSWC TR 83-492	2. GOVT ACCESSION NO. AD-A152662	3. REPORTING ORGANIZATION'S CATALOG NUMBER
4. TITLE (and Subtitle) PRESSURIZED CRYSTALLIZATION OF ALUMINUM ALLOY AA 5086	5. TYPE OF REPORT & PERIOD COVERED Final	
7. AUTHOR(s) H. DeJarnette, A. Divecha, S. Karmarkar W. Willard		6. PERFORMING ORG. REPORT NUMBER
9. PERFORMING ORGANIZATION NAME AND ADDRESS Naval Surface Weapons Center (Code R32) White Oak Silver Spring, MD 20910		8. CONTRACT OR GRANT NUMBER(s)
11. CONTROLLING OFFICE NAME AND ADDRESS David Taylor Naval Ship Research and Development Center (Code 2803) Annapolis, MD 21402		10. PROGRAM ELEMENT, PROJECT, TASK AREA & WORK UNIT NUMBERS Task 4.1 (R32JA)
14. MONITORING AGENCY NAME & ADDRESS (if different from Controlling Office)		12. REPORT DATE 4 January 1984
		13. NUMBER OF PAGES 28
		15. SECURITY CLASS. (of this report) UNCLASSIFIED
		15a. DECLASSIFICATION/DOWNGRADING SCHEDULE
16. DISTRIBUTION STATEMENT (of this Report) Approved for public release; distribution unlimited.		
17. DISTRIBUTION STATEMENT (of the abstract entered in Block 20, if different from Report)		
18. SUPPLEMENTARY NOTES		
19. KEY WORDS (Continue on reverse side if necessary and identify by block number) Casting Aluminum Alloys, Casting Squeeze Casting Liquid Metal Forging. Pressurized Crystallization		
20. ABSTRACT (Continue on reverse side if necessary and identify by block number) The effects of applying pressure to a solidifying aluminum alloy were studied using a factorial experimental design with independent variables of (1) mold temperature, (2) melt temperature, (3) pressure, and (4) extent of rolling. The tensile yield stress, ultimate tensile strength, percent elongation, and the ratio NTS/YS (notched tensile strength/yield strength) were measured. The properties of the pressurized ingots were generally superior to those of the unpressurized ingots. Yield stress was but slightly affected by pressure		

DD FORM 1473
1 JAN 73

EDITION OF 1969 IS OBSOLETE
S/N 0102-LF-014-6601

UNCLASSIFIED

SECURITY CLASSIFICATION OF THIS PAGE (When Data Entered)

UNCLASSIFIED

SECURITY CLASSIFICATION OF THIS PAGE (When Data Entered)

20. (Cont.)

→ application. Ultimate tensile strength was occasionally increased by pressure application. Ductility was almost always increased by pressurization. The toughness, as measured by the NTS/YS ratio, showed no dependence on the elongation to failure.

Originator supplied key words included: → print

UNCLASSIFIED

SECURITY CLASSIFICATION OF THIS PAGE (When Data Entered)

FOREWORD

This work was sponsored by Dr. Hans Vanderveldt, Naval Systems Command (SEA 05R25) and Dr. Robert Hardy, Naval Ship Research and Development Center (Code 2803) as Task 4.1 (R32JA). The purpose of the work was to determine the effects of solidification under pressure on the tensile properties of an aluminum alloy (AA 5086). Tensile properties were determined for ingots solidified under seventeen combinations of four independent variables. The chief result is that ingots that were solidified under pressure had greater elongation to failure but not necessarily more toughness.

The authors wish to extend their thanks to Richard E. Jones for his assistance in the melting and casting for each of the ingots.

Approved by:

Jack R. Dixon
JACK R. DIXON, Head
Materials Division

S DTIC
ELECTE **D**
APR 22 1985
B



Accession For	
NTIS GRA&I	<input checked="" type="checkbox"/>
DTIC TAB	<input type="checkbox"/>
Unannounced	<input type="checkbox"/>
Justification	
By	
Distribution/	
Availability Codes	
Avail and/or	
Dist	Special
A-1	

CONTENTS

	<u>Page</u>
INTRODUCTION	1
FLAW CAUSATION	1
FLAWS AND PRESSURIZED CRYSTALLIZATION	2
EXPERIMENTAL	3
DESIGN OF EXPERIMENT	3
EXPERIMENTAL PROCEDURE AND EQUIPMENT	5
RESULTS	8
ELONGATION	8
ELONGATION AND NOTCHED TENSILE TEST	11
YIELD STRENGTH AND ULTIMATE TENSILE STRENGTH	11
PRESSURIZATION VERSUS ROLLING	13
DISCUSSION	16
CONCLUSIONS AND RECOMMENDATIONS	19
CONCLUSIONS	19
RECOMMENDATIONS	19

ILLUSTRATIONS

<u>Figure</u>		<u>Page</u>
1	EXPLODED VIEW OF MOLD	6
2	INGOT MACHINED FOR ROLLING	7
3	NTS/YS RATIO VS. ELONGATION	12

TABLES

<u>Table</u>		<u>Page</u>
1	RANGES OF INDEPENDENT VARIABLES	4
2	VALUES OF INDEPENDENT VARIABLES BY INGOT.	4
3	EXPERIMENTAL DATA IN ORDER OF ELONGATION TO FAILURE	9
4	TENSILE DATA FOR MOST DUCTILE INGOTS	10
5	AVERAGED DUCTILITIES OF INGOTS	11
6	EFFECT OF PRESSURIZED CRYSTALLIZATION ON YS AND UTS	14
7	EFFECTS OF PRESSURIZED CRYSTALLIZATION AND ROLLING COMPARED	15
8	EFFECT OF MELT/MOLD TEMPERATURES ON UTS OF UNROLLED INGOTS	17
9	COMPARISON OF PRESSURE CRYSTALLIZED WITH "0" TEMPER 5086	18

INTRODUCTION

When metallic alloys solidify, they both cool and contract unevenly; these processes cause flaws in the solid that can be countered only by expending energy (e.g., rolling, forging, remelting, etc.). This report presents experimental evidence that the application of several thousand pounds of pressure to the solidifying metal will forestall (or repress) many of these flaws and thereby result in better properties in the as-cast ingot. Moreover, there is some evidence that pressurization and subsequent rolling can act synergistically; i.e., they combine to give better properties than either can provide by itself.

p. 1473

FLAW CAUSATION

"Pipe" is the most obvious flaw caused by contraction and uneven cooling; the outer part of the melt, that part in contact with the mold, solidifies first and thereby becomes a container for the still-molten core. When the core solidifies, its shrinkage as it undergoes the phase transformation* means that there will be an empty volume at the ingot's center. This volume, or pipe, can be lessened by using "hot-tops," but the vestigial pipe must be cut off before further processing, thereby creating scrap.

Inverse segregation is related to pipe formation in that the "container" that is formed by the first portion of the alloy to solidify sometimes ruptures and allows the solute-enriched and still-molten core to flow into the air gap between the container and the mold wall. (The air gap, created by the contraction of the metal during the phase change, is for many aluminum alloys, particularly large; aluminum shrinks about 12 percent in casting.) The uneven distribution in solute created by inverse segregation is usually too great to be overcome by homogenization and therefore results in scrapping of the ingot.

Gas porosity is caused by the lessened solubility of hydrogen in aluminum at lower temperatures. The solubility drops drastically as solidification occurs. The hydrogen in the aluminum comes from water (atmospheric humidity) that has had its oxygen stripped away by the aluminum. As the hydrogen comes out of solution, it forms cavities (gas porosity) in the ingot. Shrinkage porosity, on the other hand, is caused by the separation of the fluid and the solid at the interface and is due to the combination of thermal contraction with resistance to the interdendritic flow that is felt by the melt. The effect of

*Only alloys that shrink upon solidification are treated in this analysis.

all porosity is reduction of cross-sectional area of the ingot with attendant loss of strength. Also, the pores may act as fracture- or fatigue-crack initiators.

Poor surface finish, caused in conventional ingots by the ingot's shrinkage from the mold wall during initial solidification, usually necessitates scalping. This step is a machining operation and is therefore labor intensive; its elimination would be a significant monetary saving.

Residual stresses are caused by uneven cooling and uneven contraction during solidification. The outer shell of the partly-solidified ingot has been rigid for some seconds by the time the central part of the ingot solidifies. As the core undergoes a phase change, it attempts to contract, but cannot as it is bound to the outer shell. This places the core under radial tension and the shell under circumferential compression. This residual stress can sometimes split ingots, and in less severe cases it can defeat attempts to produce precision-machined parts by warping the part as metal is machined away.

Because fine grains retard fatigue crack initiation and raise tensile strength,* the columnar grains that are characteristic of cast structures are generally not desired. They can be repressed by pressurized crystallization.

FLAWS AND PRESSURIZED CRYSTALLIZATION

The above section stressed that the solidification process is the origin of a variety of flaws in the resulting ingot, billet, or casting. This has been done to communicate the idea that, although some processing steps (such as rolling a billet to foil, or forging to get a finished part of sufficient strength) have correction of the built-in flaws as an ancillary effect, a large amount of labor, energy, or material is expended solely to rid cast structures of flaws. Pressurized crystallization will repress or eliminate many of these flaws, as will now be discussed.

Pipe is completely eliminated by pressurized crystallization. Although mass must flow during the pressurized solidification process, macro-etched longitudinal samples of pressure-cast ingots only rarely show flow lines. Apparently, flow takes place while almost complete plasticity is retained.

Inverse segregation is similarly eliminated; the air gap between the ingot and the mold wall that is necessary for inverse segregation never forms during pressurized crystallization.

Shrinkage porosity is eliminated or curtailed by pressurized crystallization for obvious reasons. Gas porosity can only form when the vapor pressure at some site exceeds the applied pressure.

*Fine grains are produced by the same events that cause fine dendritic arm spacings. Currently, it is believed that fine dendritic arm spacings are the cause of higher strength, not fine grains.

Because the solidifying metal is held in contact with the mold, the surface of the ingot has a finish as good as that of the mold. Therefore the irregularities that form on a conventional ingot's surface need not be scalped from the surfaces of pressure crystallized ingots. Moreover, the close contact (the lack of an air gap) results in excellent thermal contact and in an improved rate of heat flow from the solidifying ingot; this is important as faster rates of solidification result in improved tensile properties.

Pressurized crystallization can produce ingots with equiaxed, small grains. It is hypothesized that because the liquidus line is raised by pressure, and because only a little superheat remains after the melt has been poured into the mold, then the melt is supercooled several degrees by sudden application of pressure. This supercooling should increase the nucleation rate throughout the ingot and thereby cause a fine-grained structure.

An additional hypothesis is that pressurized crystallization reduces residual stresses in the as-cast ingot. Edwin Hodge of AiResearch, Torrance, California, has found that hot isostatic pressing (HIPing) produces 5086 aluminum billets that have lowered residual stresses. In pressurized crystallization, the pressure initially puts the entire liquid under hydrostatic (i.e., equiaxed) compression that continues as long as the solidifying piece is plastic. Although not tested in this work, it is at least plausible that pressurized crystallization produces ingots free of residual stresses.

EXPERIMENTAL

The experiment was designed to see if the properties of pressure crystallized material are superior to those of conventionally cast (i.e., unpressurized) ingots before and after both have been rolled. Because there are no data available on the tensile properties of unpressurized, un-rolled 5086 alloy ingots, unpressurized casting had to be made for comparison.

DESIGN OF EXPERIMENT

There were four independent variables (mold temperature, melt temperature, pressure applied to the melt, and extent of reduction by rolling) and four dependent variables (elongation to failure, 0.2 percent yield stress, ultimate tensile strength, and a measurement indicative of toughness).

A "factorial" experimental design was chosen. This design efficiently gives direct comparisons between ingots cast under a wide variety of different conditions. For example, one can compare the elongation to failure of two unrolled ingots of the same size, cast at the same melt and mold temperatures, but cast at differing pressures. One can also directly compare ingots that are identical except for a change in any one of the other independent variables.

In a factorial experiment, each independent variable can have only one of three values: a high value (+), a mid-point value (0), or a low value (-). The high, mid-point, and low values for this work are shown in Table 1. A factorial experiment with four independent variables requires that data be taken at $2^4+1=17$ points in "data space;" Table 2 shows the values of the independent variables for each of these points. To simplify the Table, a (+), (0), or (-) is inserted instead of the variable's numerical value which can be found in Table 1. Note that in Table 2 each data point has at least one (and as many as three) "Ingot numbers" assigned to it; these correspond to the ingots cast under the stated conditions. Two data points were replicated: The mid-point was replicated three times, and the point (melt temperature: 1550°F, mold temperature: 1000°F, pressure: 12,000 psi, 50 percent reduction by rolling) was replicated twice.* The ingots were cast in the order of their numbers (#24 was cast first, #43 last); casting was done in random order to counter systematic error.

A total of 20 ingots were cast (actually, 21 ingots were cast, but the first, #23, was discarded--it was replaced by #24 and #25).

TABLE 1. RANGES OF INDEPENDENT VARIABLES

		<u>Melt Temp.</u> (°F)	<u>Mold Temp.</u> (°F)	<u>Pressure</u> (ksi)	<u>Rolling Reduction</u> (%)
Low Value	(-)	1350	70	0	0
Mid-Point Value	(0)	1450	500	6	50
High Value	(+)	1550	1000	12	50

TABLE 2. VALUES OF INDEPENDENT VARIABLES BY INGOT (See Text)

<u>INGOT NUMBERS</u>	<u>Melt Temp.</u>	<u>Mold Temp.</u>	<u>Pressure</u>	<u>Rolling Reduction</u>
32,42,43	0	0	0	0
28	-	-	-	-
34	-	-	-	+
38	-	-	+	-
30	-	-	+	+
33	-	+	-	-
31	-	+	-	+
27	-	+	+	-
37	-	+	+	+
35	+	-	-	-
41	+	-	-	+
36	+	-	+	-
29	+	-	+	+
39	+	+	-	-
40	+	+	-	+
26	+	+	+	-
24,25	+	+	+	+

*Mid-point ingots: #32,42,43; other replicates: #24,25

EXPERIMENTAL PROCEDURE AND EQUIPMENT

The principal pieces of equipment were the mold assembly, the furnace, and the electro-hydraulic press. The furnace was an electric muffle furnace; melting was done in air. In the furnace, the temperature of the melt was measured by a stainless-steel-clad, 1/16" diameter, chromel-alumel thermocouple which was monitored by a strip chart recorder so that pouring could take place as soon as the melt came up to temperature. When this occurred, the crucible was removed from the furnace, the melt was skimmed, and the metal was poured into the mold. Pressure was applied via a steel plunger that was driven down onto the melt by the hydraulic press. Full pressure was achieved about 15 seconds after pouring.

The mold assembly consisted of three parts that made contact with the melt (plunger, liner, and plug) and four parts that constrained the liner and plug during application of pressure (base plate, outer ring, and a split adaptor-annulus). These are shown in Figure 1. The outer ring, base plate, and adaptor annulus were made of alloy steel. The liner and plug were made of mild steel; the liner was made from steel tubing. These tubes were machined inside to taper them so that the ingots would be easy to remove; the ingot diameter at the top was 2 1/16", and at the bottom it was 2 1/4". Both liner and plug were coated with colloidal graphite before use, as was the tool steel plunger. The mold assembly was brought to temperature by a ring heater, a ceramic annulus 8" high that had embedded heating elements. Electric power to the heater was controlled by a three-mode controller that sensed a thermocouple embedded in the mold wall.

The pressure was applied to the plunger by a hydraulic pump and cylinder with an electric motor as prime mover. The pressure applied to the melt was 12,000 psi, maximum. The plunger was inserted as soon as possible after the liquid was poured into the mold, and then the hydraulic ram was lowered. The pressure was applied to the ingot for approximately 90 seconds from the attainment of full pressure. Following the release of pressure, the base plate of the mold was removed, and the ingot was pressed out and allowed to air cool.

One lot of AA 5086 aluminum alloy extruded bar was cut into about 5" long pieces, and bars from this lot were always used to charge the crucible. No flux, grain refiner, or deoxidizer was added to the melt. One exception to the last sentence is noted below.

After casting, flats were machined onto those ingots that were to be rolled, and the front edge was tapered for ease of rolling as shown in Figure 2. The thickness between the flats was 1.5". Rolling was done at 750°F.

At least one tensile specimen (1.40" gage length, 0.350" diameter) was cut from the bottom of each ingot. For the pressurized ingots, a second tensile specimen was cut from the top of the ingot; for the unpressurized ingots, the pipe prevented the second tensile sample.

Notched tensile specimens (according to ASTM E 602-76T) were also cut from the bottom of each ingot. From the pressurized ingots, a second notched specimen was cut from each top; but, as in the case of smooth tensile specimens, pipe precluded a second sharp notch tensile specimen from unpressurized ingots.

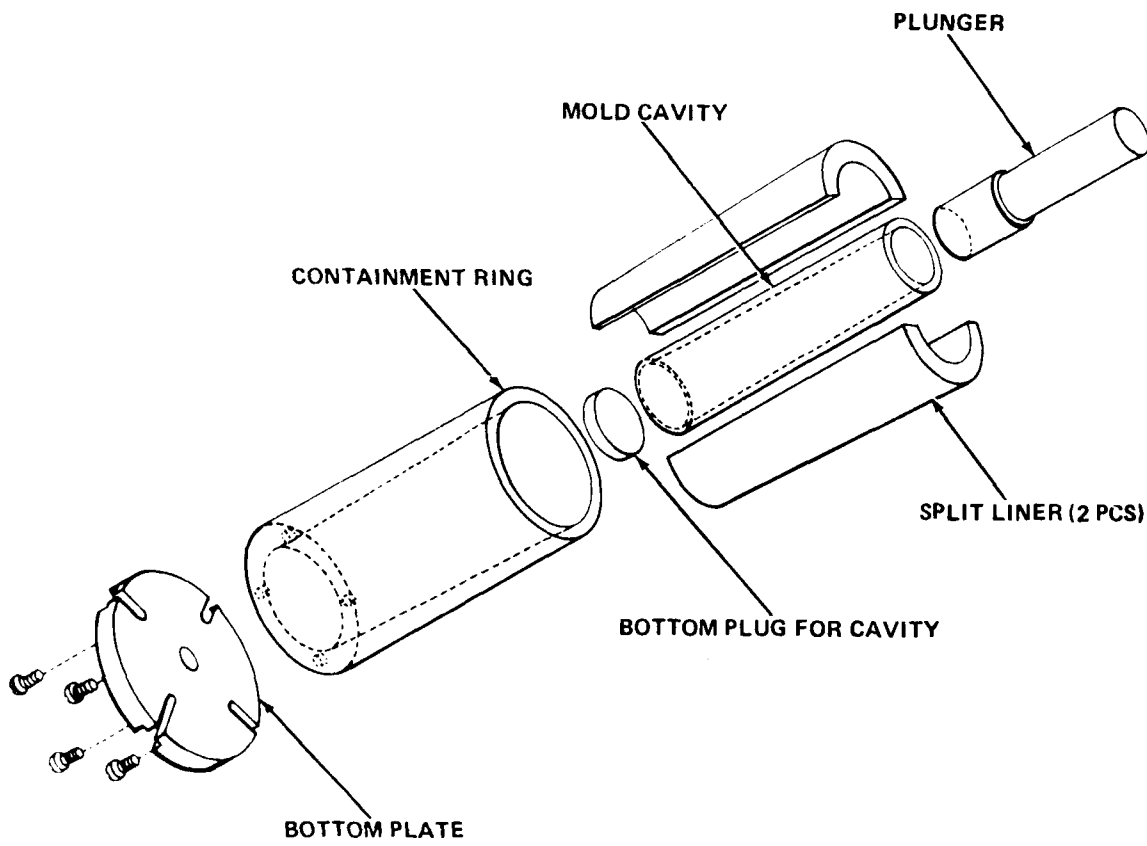

FIGURE 1. EXPLODED VIEW OF MOLD

- . The effects of higher pressure should be examined. Pressures two or three times higher than the highest pressure (12 ksi) used here should be tested.
- . The method of pressurized crystallization should be considered as a technique for increasing the amount of hydrogen in an aluminum matrix. Hydrogen-enriched aluminum could be a useful material in hydrogen embrittlement research. At present, introduction of hydrogen into already solid aluminum via cathodic charging is accompanied by acid dissolution of the specimen.
- . Because the tops of pressurized ingots have worse tensile properties than the bottoms, it important to find both why this occurs and how it can be prevented.
- . Ultimately, a body of knowledge concerning the trade-offs between hot isostatic pressing and pressurized crystallization will develop. A deliberate effort to compare properties of identically sized ingots and casting made by both methods would provide earlier guidance for choosing between the two methods.
- . Pressurized crystallization of this alloy should be considered for making castings that must have excellent elongations.

CONCLUSIONS AND RECOMMENDATIONS

CONCLUSIONS

1. The most easily visible benefits of pressurization are the elimination of pipe from the ingots and the improvement of the surface quality of the ingots. Moreover, sectioning and macro-etching showed uniform grain structure and small grains throughout the ingots.
2. The elongation to failure (percent Elongation) is higher in specimens from the pressurized ingots. The highest elongation (30 percent) is from a pressure-crystallized, as-cast ingot (melt temperature 1550°F, mold temperature 70°F, un-rolled). This value is reproducible.
3. Yield stress (YS) was generally insensitive to pressurization. YS from un-rolled ingots ranged from 14.8 to 16.5 ksi; from rolled ingots from 16.8 to 25.0 ksi.
4. Ultimate tensile strength (UTS) increased with pressurization by a maximum of 10 ksi.
5. The independent variables interact; the effect that a given independent variable has on a dependent variable is determined by the values of other independent variables.
6. There is no proof for a relationship between the NTS/YS values and the elongations to failure. Elongation measurements ranged from less than 10 percent to 30 percent (a ratio of more than 3) while NTS/YS values ranged from less than unity to 2.57, but no trend (that could not be attributed to random variation) was found in a scatter plot that compared the two sets of values.
7. For unrolled ingots, at low melt/mold temperatures (1350°F/70°F), high values of UTS result from chill casting and are largely independent of pressurization at least for this alloy, this size ingot, and this pressure. If melt temperature is raised to 1550°F, pressurization is important to UTS for low mold temperatures only: an increase of 6 ksi in UTS is found.

RECOMMENDATIONS

1. The melt temperature used herein was the melt temperature upon pouring. More valuable information would be gained if the melt temperature upon pressure application could be measured. In particular, one could find the effect on dependent variables when pressure was applied while the melt temperature was near the liquidus line.
2. The effects of the surface-to-volume ratio on the dependent variables are still unknown. Work on larger ingots with the same height-to-diameter ratio as described here (3:1) would determine if this is an important variable. Work on ingots of the same weight, but with larger diameters and shorter heights (i.e., gear blanks) would also supply basic as well as applied knowledge.

Although attempts were made to monitor the temperature of the molten metal in the mold with the intent of applying pressure at selected degrees of superheat, the effort was abandoned when it was found that the development of a thermocouple feed-through would require a disproportionate amount of money and time: the device would have to insulate the thermocouple wires from each other at 1550°F and withstand 12 ksi pressure. Instrumentation was developed that would provide real-time display of temperature versus time; lack of a feed-through, however, prevented getting the signals to the instrument.

Information from the feed-thru would have aided diagnosis and cure of the following phenomenon: In pressurized ingots, the YS, UTS, and percent Elongation in the bottoms of ingots were better than those in their tops. Doubtless, any point in the bottom of the ingot will have a temperature versus time trace that is both steeper (faster rate of heat loss) and lower (lower temperature at any given time) than that of a similar point in the top of the ingot. Without these traces, attempts to fabricate an ingot with more uniform properties will continue to be unguided.

The causes of poorer properties in the tops of pressurized ingots could be simple: vestigial gas porosity could rise like bubbles to freeze in the top of the ingot, or the cause could be that fluid flow must occur when the phase change tries to form a pipe but is frustrated by the pressure. Of course, as inferior to the bottoms as the tops are, they are superior to those of unpressurized ingots whose tops cannot supply tensile specimens.

Finally, pressurized crystallization supplies ingots that meet or surpass standards for "0" temper AA 5086.³ The 0 temper implies recrystallization which in turn implies rolling. In contrast, ingots 36 and 58 in Table 9 are tested in the as-cast condition. (values are averages of 3 specimens).

TABLE 9. COMPARISON OF PRESSURE CRYSTALLIZED WITH "0" TEMPER 5086

Melt/Mold/Press.	Ingot Nos.	Elong.	UTS	YS
(°F/°F/ksi)	(-)	(%)	(ksi)	(ksi)
"0" Temper	----	16 min.	35-44	14 min.
1550/70/12	368/58-1 58-2	27.8	35.4	15.4

³Aluminum Association, Aluminum Standards and Data (Washington, D.C., 1979), p. 101.

The mid-point ingots would, ideally, have been rolled 25 percent rather than 50 percent. They were rolled the full 50 percent so they could be compared more directly with other rolled ingots.

The relationship between the mold temperatures, the melt temperatures, the application of pressure and the percent Elongation may have the following simple explanation, at least for unrolled (as-cast) ingots. At low melt temperatures (1350°F) and room temperature molds, one is essentially chill-casting and, even without pressure, would expect to get good properties from the rapid cooling rate. This is borne out by the last pair of entries in Table 8.

Because of this rapid cooling, pressurization would occur after a significant fraction of the alloy had become mushy, and dendrites could be sheared, broken, or otherwise damaged to degrade the ingot's percent Elongation.*

On the other hand, if the melt temperature were raised, using still a room-temperature mold, then pressurization would occur while the alloy would be hotter: More alloy would be liquid. Also, the solid fraction would be more plastic and would withstand pressurization with less mechanical damage to dendrites. Pressurization could effect an improvement in UTS. See the second pair of entries in Table 8 (1550/70).

Should the melt/mold temperatures be raised too high, however, the melt would be so far above the liquidus that the pressurization would be insufficient to produce supercooling. The accelerated nucleation rate associated with supercooling would be lacking. The first pair of entries in Table 8 shows a comparative loss in UTS upon pressurization at high melt and mold temperatures.

TABLE 8. EFFECT OF MELT/MOLD TEMPERATURES ON UTS OF UNROLLED INGOTS

MELT TEMP./MOLD TEMP. °F/°F	PRESSURIZED (Yes/No)	UTS (ksi)	COMMENT
1550/1000	Y	23.0	Pressurization
1550/1000	N	31.1	Ineffective
1550/70	Y	36.5	Pressurization
1550/70	N	30.1	Effective
1350/1000	Y	33.9	Pressurization
1350/1000	N	29.3	Fairly Effective
1350/70	Y	37.1	Pressurization
1350/70	N	36.3	Ineffective

*The authors acknowledge Mr. Thomas Bosworth (Boeing Aerospace Co., Seattle) for this discussion.

In summary, when pressurized-crystallization-alone and rolling-alone produce equal tensile properties, the combination of the two processes produces superior tensile properties, that is, at melt/mold temperatures of 1550/1000°F, pressure and rolling are synergistic. At other melt/mold temperatures, the combination of pressure, and rolling is less beneficial; this shows that the independent variables interact.

DISCUSSION

The goal of this section is to discuss the effects of the four independent variables on the four dependent variables. Ingots were cast under seventeen unique combinations of the independent variables. The results painted in broad strokes the effects of melt temperatures, mold temperature, reduction by rolling, and pressurized crystallization on the variables: YS, UTS, NTS/YS, and percent Elongation. The data tell us: (1) the maximum of each dependent variable, (2) the corresponding values of the other dependent variables, and (3) the sensitivity of the dependent with respect to the independent variables.

For example, if maximum ductility is wanted, 30 percent Elongation would be expected from an ingot cast at a melt temperature of 1550°F into a mold at 70°F, pressurized at 12 ksi, and not rolled. And we know that this ductility is fairly sensitive to melt temperature, fairly sensitive to mold temperature, and very sensitive to the use of pressure.

The independent variables interact. That is, the effect of one independent variable on a given dependent variable depends on the values of the other independent variables. This is illustrated by the synergy documented in the section above.

To estimate the reproducibility, replicate ingots were cast at two of the seventeen combinations of independent variables. The first two ingots cast (#24,25) were replicates, and their UTS, YS, and NTS/YS values agreed fairly well, while their percent Elongations differed widely (14 vs. 26 percent). The mid-point was replicated three times: once halfway through the series and twice at the end (ingots #32,42,43). These three ingots gave values of all independent variables that agree very well with each other. The reproducibility of data improved from fair to excellent as the casting proceeded.

For room temperature molds, an increase in pressure either raises or leaves unaffected the percent Elongation for all combinations of melt temperature and reduction by rolling save one: Elongation decreases only if pressure is used at a melt temperature of 1350°F and with zero reduction by rolling.

For mold temperatures of 1000°F, however, the above pattern does not repeat. In fact, for melt temperature of 1550°F and zero rolling (i.e., when percent Elongation increases markedly upon pressurization for room temperature molds) the percent Elongation decreases upon pressurization in 1000°F molds. The interaction of variables makes a brief description of the data difficult.

The mid-point ingots possess values of dependent variables intermediate to those values found in ingots cast at extreme values of independent variables. This implies that the greatest elongations, and the highest strengths, are found at the extremes of melt/mold temperatures, pressures, and reductions by rolling.

TABLE 7. EFFECTS OF PRESSURIZED CRYSTALLIZATION AND ROLLING COMPARED

MELT/MOLD TEMP (°F)/(°F)	PRESSURE APPLIED YES/NO	ROLLED YES/NO	INGOT #	ELONG (%)	UTS (KSI)	YS (KSI)
1550/1000	Y	Y	24/25	14.4/ <u>26.4</u>	38.5/ <u>39.7</u>	21.2/ <u>17.7</u>
	N	Y*	40	7.3	28.7	18.7
	Y	N	26T/26B	6/-	23.0/-	15.4/-
	N	N	39B	10.5	31.1	15.5
1550/70	Y	Y	29	15.5	<u>43.3</u>	<u>23.9</u>
	N	Y	41	14.2	<u>44.3</u>	<u>25.0</u>
	Y	N	36T/36B	<u>-/30.0</u>	<u>36.1/36.5</u>	<u>15.9/16.5</u>
	N	N	35	<u>9.2</u>	30.1	16.2
1350/1000	Y	Y**	37	5.5	<u>33.1</u>	<u>21.0</u>
	N	Y	31	7.1	<u>33.7</u>	<u>16.8</u>
	Y	N	27T/27B	22.8/11.2	<u>30.2/33.9</u>	15.1/16.3
	N	N	33	10.0	29.3	15.3
1350/70	Y	Y	30	<u>21.8</u>	<u>44.4</u>	<u>24.5</u>
	N	Y**	34	<u>16.2</u>	<u>39.5</u>	<u>21.6</u>
	Y	N	38T/38B	3.8/25	26.6/37.1	16.0/14.8
	N	N	28	15.5	36.3	16.3

*18.8% reduction

**37.5% reduction

TABLE 6. EFFECT OF PRESSURIZED CRYSTALLIZATION ON YS AND UTS

(a) UN-ROLLED INGOTS

MELT TEMP (°F)	MOLD TEMP (°F)	YIELD STRESS (ksi)		ULTIMATE TENSILE STRENGTH (ksi)	
		No Pressure	12 ksi Pressure	No Pressure	12 ksi Pressure
1550	1000	15.5	15.4*	31.1	23.0*
1550	70	16.2	16.5	30.1	36.5
1550	70	----	15.9*	----	36.1*
1350	1000	15.3	16.3	29.3	30.2*
1350	1000	----	15.1*	----	33.9
1350	70	16.3	14.8	36.3	37.1
1350	70	----	16.0*,**	----	26.6*,**

*Ingot Top

**Failed in Threads

(b) ROLLED INGOTS

MELT TEMP (°F)	MOLD TEMP (°F)	YIELD STRESS (ksi)		ULTIMATE TENSILE STRENGTH (ksi)	
		No Pressure	12 ksi Pressure	No Pressure	12 ksi Pressure
1550	1000	18.7 [†]	21.2	28.7 [†]	38.5
1550	1000	----	17.7	----	39.7
1550	70	25.0	23.9	44.3	43.3
1350	1000	16.8	21.0 ^{††}	33.7	33.1 ^{††}
1350	70	21.6 ^{†††}	24.5	39.5 ^{†††}	44.4

[†]Withstood only 18.8% Reduction.^{††}Withstood only 37.5% Reduction.^{†††}Withstood only 37.5% Reduction.

If specimens are paired so that, in each pair, all have the same melt and mold temperatures and extent of rolling, but so that one is pressurized while the other is not, then the extent of the effect of pressurized crystallization on yield stress and ultimate tensile strength can be measured. This is done in Table 6(a) and 6(b). These tables show that yield stress is but slightly affected by pressurization. The maximum effect is seen in the rolled ingots cast at a melt temperature of 1350°F and a mold temperature of 1000°F: pressurization increased yield stress from 16.8 to 21.0 ksi.

For the ultimate tensile strength on the other hand, the pressurization affects both the rolled and the un-rolled ingots. For un-rolled ingots, the pressure increases the UTS of ingots cast at melt temperatures of 1550°F and the mold temperatures of 70°F by 6 ksi. For melt temperatures of 1550°F and mold temperatures of 1000°F, pressurization lowers UTS by approximately 8 ksi. For the rolled ingots, the UTS increases by up to 10 ksi (melt temperature = 1550°F, mold temperature = 1000°F); and in a second pairing, UTS increases by about 5 ksi (melt temperature = 1350°F, mold temperature = 70°F).

PRESSURIZATION VERSUS ROLLING

It was assumed, for the sake of experimental design, that all of the benefits of pressurized crystallization resulted from the repression of porosity. Further, it was assumed that any porosity would be healed by rolling. If both of these assumptions are true, then the same tensile properties should result from two (otherwise) identical ingots if one is only pressure crystallized and the other is only rolled. Table 7 lists, for four combinations of melt/mold temperatures, the tensile properties of the ingots. In the table, for each melt/mold temperature combination, the highest (or the two highest) values of the percent Elongation, UTS, and YS have been underlined. As expected, ingots that were neither pressure crystallized nor rolled never had the highest tensile properties. Also ingots that were both pressure crystallized and rolled usually had superior tensile properties when compared to other ingots cast at the same melt/mold temperatures.

In comparing the properties of ingots that were only pressure crystallized with the properties of ingots that were only rolled, the surprising conclusion is that the melt/mold temperatures strongly affect the results:

1. at melt/mold temperatures of 1550/1000 (°F/°F), pressure-crystallized-only properties fairly well match rolled-only properties, (but these properties are inferior to the properties from ingots that were both pressure crystallized and rolled),
2. at melt/mold temperatures of 1550/70 (°F/°F) no pressure-crystallized properties match rolled-only properties,
3. at melt/mold temperatures of 1350/1000 (°F/°F) only the UTS's and YS's match, and,
4. at melt/mold temperatures of 1350/70 (°F/°F), only the UTS's match.

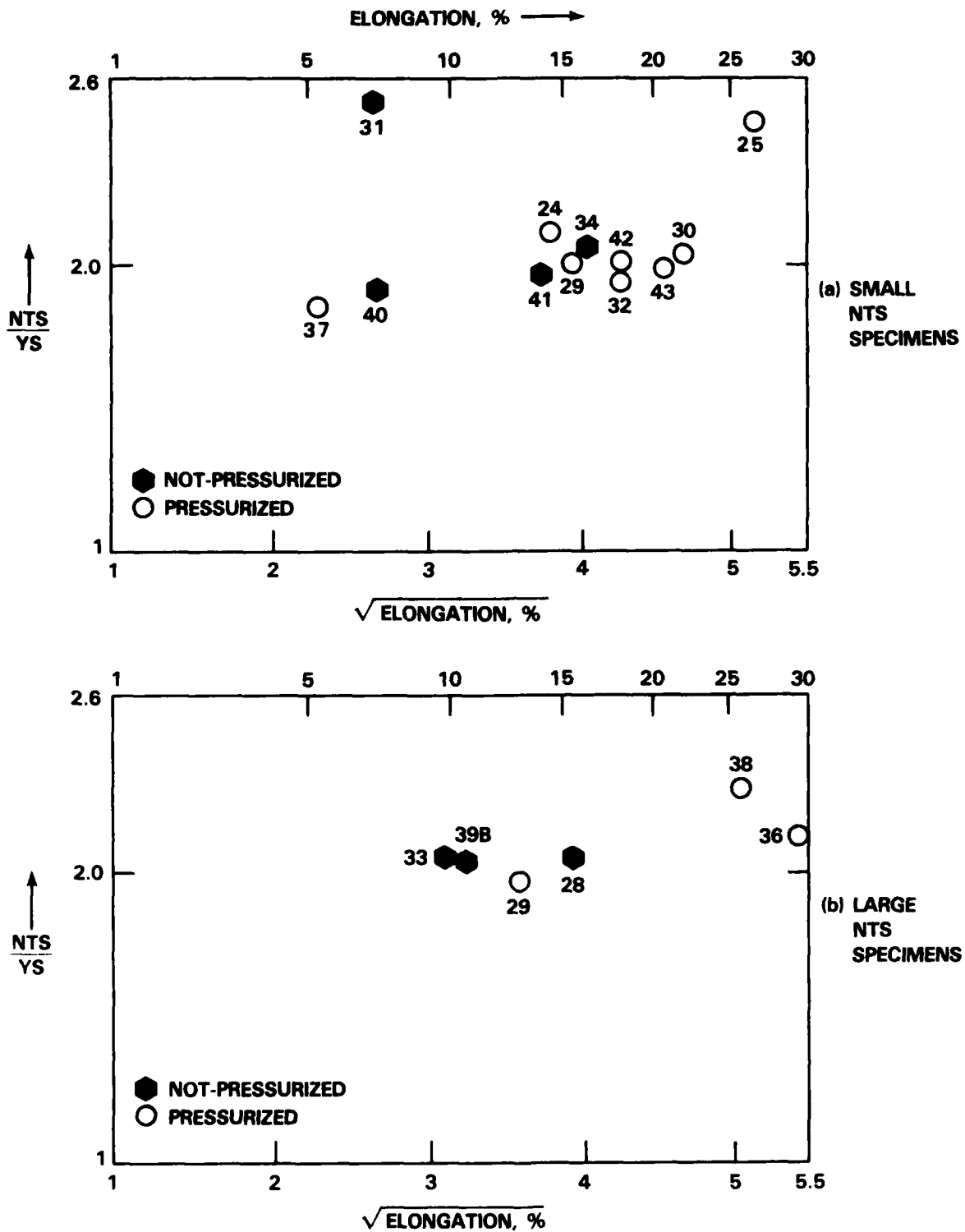

FIGURE 3. NTS/YS RATIO VS. $\sqrt{\text{ELONGATION}}$

TABLE 5. AVERAGED DUCTILITIES OF INGOTS

	<u>ZERO PRESSURE</u>	<u>6 KSI PRESSURE</u>	<u>12 KSI PRESSURE</u>
Average Elongation	10.0% (9 specimens)	19.0% (3 specimens)	16.6% (11 specimens) (#36T excluded)

ELONGATION AND NOTCHED TENSILE TEST

The results from the "notched tensile test"² were equivocal. Two questions were to have been answered by the data. First, does pressurized crystallization provide tougher ingots? Second, is the toughness of the ingots proportional to the square root of their percent Elongation?

The answer to the first question is ambiguous because, when the data are listed in order of ascending NTS/YS ratios (NTS is the tensile stress at which the notched specimens fail), the top quartile of entries (toughest specimens) contain four pressurized ingots and one unpressurized ingot. This does not compel belief that pressurized ingots are usually tougher.

The answer to the second question is also ambiguous. There is no marked change in the "toughness" (as indicated by the NTS/YS ratio) as the ductility increases. Figure 3 shows the scatter plots used to reach this conclusion. In the figure, data from small notched tensile specimens 3(a) are distinguished from data from large notched tensile specimens 3(b) because the larger specimens tend to yield lower values of NTS/YS than small specimens. (Both specimen sizes were used because, while large specimens are more desirable, only small specimens could be cut from the rolled ingots.) Not all NTS/YS ratios are shown in Figure 3 as ratios from ingots' tops were excluded: YS values from the tops were generally low and thereby inflated the ratios. The abscissa is in terms of "square root of percent Elongation" rather than linear in elongation to accentuate any slope that may be present. In general, there is no demonstrated relation between changes in NTS/YS and changes in ductility. If only pressurized ingots are considered, any slope to the toughness as a function of elongation line could be merely a result of random variation. The results neither exclude a relationship nor prove that one exists.

YIELD STRENGTH AND ULTIMATE TENSILE STRENGTH

The rolled ingots had the highest values of both yield strength and ultimate tensile strength. Pressurized crystallization will occasionally equal, but not surpass, rolling as a means of increasing the YS or UTS.

²ASTM E 602-78T, "Tentative Method for Sharp-Notch Tension Testing with Cylindrical Specimens."

that pressurization improves the ductility of the alloy in both the as-cast and the rolled condition. This supplements conclusions drawn from earlier work on smaller ingots of the same alloy.¹

The highest ductility was found in ingot #36. While the top of this ingot (#36T) extended 38 percent before failure, this value was not reproduced; however, the bottom of the ingot (#36B) extended 30 percent, and this value was reproduced. A second ingot (#58) was cast duplicating #36 with but one change -- the melt for #58 was fluxed after melting -- and the tensile data from this ingot are compared with those from #36 in Table 4.

TABLE 4. TENSILE DATA FOR MOST DUCTILE INGOTS
(See text for independent variables)

<u>INGOT NO.</u>	<u>ELONG (%)</u>	<u>YS (ksi)</u>	<u>UTS (ksi)</u>
#36-Top	38.0	15.9	36.1
#36-Bottom	30.0	16.5	36.5
#58-mid*	29.4	14.9	35.0
#58-mid*	24.3	14.9	34.6
Av. (excluding #36-top)	27.9	15.4	35.4

*Fluxed

Neglecting the irreproducible 38 percent, this combination of values of independent variables (Temp. melt = 1550°F, Temp. mold = 70°F, 12 ksi pressure, no rolling) still gives the highest average elongation of all ingots. In contrast, the same melt and mold temperatures and amount of rolling but without pressurization give an elongation of only 9.2 percent (ingot #35). For this ingot, both the smooth tensile and the notched tensile specimen broke at flaws.

For further comparison, the percent Elongations are averaged over all of the ingots that were fully (12 ksi) pressurized, half-pressurized, or unpressurized and are listed in Table 5; one again sees that pressurized ingots are more ductile than unpressurized ones. In Table 5, the difference between 19.0 percent and 16.6 percent is not believed to be significant. That is, we do not believe that 6 ksi pressurization reliably produces elongation superior to ingots prepared at 12 ksi. The difference between these two percentages and the 10 percent Elongation of the unpressurized ingots is held to be significant.

¹DeJarnette, H. M., Divecha, A. P., and Karmarkar, S. D., Light Metal Age, 40, Aug 1982, pp. 17-20.

TABLE 3. EXPERIMENTAL DATA IN ORDER OF ELONGATION TO FAILURE

INGOT NO.	MELT TEMP (°F)	MOLD TEMP (°F)	PRESSURE (ksi)	ROLLING (%)	ELONG (%)	YS (ksi)	UTS (ksi)	NTS/YS	COMMENTS
39T	1550	1000	0	0	*	*	*	*	*PREMATURE BREAK IN SMOOTH TENSILE
38T	1350	70	12	0	3.8*	16.0	26.6	2.22	*BROKE IN THREADS AFTER YS, BEFORE UTS
37	1350	1000	12	37.5*	5.5	21.0	33.1	1.86	*ROLLED ONLY 35% DUE TO INGOT TEARING
26T	1550	1000	12	0	6.0	15.4	23.0	1.60	
31	1350	1000	0	50	7.1	16.8	33.7	2.57	
40	1550	1000	0	18.8	7.3	18.7	28.7	1.89	18.8 VICE 50%
26B	1550	1000	12	0	8.0				SMOOTH TENSILE PROBABLY COLD WORKED
35	1550	70	0	0	9.2*	16.2	30.1	**	*BROKE AT FLAW **NTS SPECIMEN FLAWED
33	1350	1000	0	0	10.0	15.3	29.3	2.04	
39B	1550	1000	0	0	10.5	15.5	31.1	2.04	
27B	1350	1000	12	0	11.2	16.3	33.9	2.00	
41	1550	70	0	50	14.2	25.0	44.3	1.96	
24	1550	1000	12	50	14.4	21.2	38.5	2.10	NTS BROKE AT IMPURITY
28	1350	70	0	0	15.5	16.3	36.3	2.05	
29	1550	70	12	50	15.5	23.9	43.3	2.00	
34	1350	70	0	37.5*	16.2	21.6	39.5	2.05	*ROLLED ONLY 35% DUE TO INGOT TEARING
42	1450	500	6	50	18.2	23.0	44.0	2.00	
32	1450	500	6	50	18.2	23.4	42.3	1.95	
43	1450	500	6	50	20.6	22.7	43.2	1.98	
30	1350	70	12	50	21.8	24.5	44.4	2.02	BROKE AT FLAW
27T	1350	1000	12	0	22.8	15.1	30.2	1.70	
38B	1350	70	12	0	25.0	14.8	37.1	2.30	
25	1550	1000	12	50	26.4	17.7	39.7	2.46	
36B	1550	70	12	0	30.0	16.5	36.5	2.12	
36T	1550	70	12	0	38.0	15.9	36.1	*	*NTS FAILED IN THREADS

Large (1.06" diameter) specimens were cut from all un-rolled ingots; small (0.5" diameter) specimens were cut from the ingots that had been reduced 50 percent in thickness by rolling. Although the large specimens were clearly more desirable than the small ones, large specimens could not be cut from the billets after they had been rolled. Each specimen required a notch with a root radius of 0.0007"; this sharp-tipped notch was cut with a special tool, and the tip of the notch was checked with a tool-marker's microscope to assure compliance with the ASTM standard.

RESULTS

The most important result is: Pressurized crystallization increases ductility. However, no ingot was superior to all other ingots in all respects. Of course, rolled ingots had better yield and ultimate tensile strengths than unrolled ingots, and rolled ingots tended to have less ductility. Surprisingly, the tops of pressure crystallized ingots were, in general, inferior to the bottoms of the ingots.

Because no one set of independent values resulted in an unquestionably superior ingot, there is no "best" way to present the data. A narrative description of data would be tedious and would obscure rather than illuminate. So salient results will be presented and backed up with a table. This method exploits the chief advantage of a factorial experimental design: the ability to see what happens if only one of the four independent variables is altered. Although almost all of the data can be presented in a single table, this will be done only once-in a special arrangement to help show the effect of pressurized crystallization on percent Elongation. For this section, the following outline will be used:

ELONGATION
ELONGATION AND NOTCH TENSILE TEST
YIELD STRESS AND ULTIMATE STRENGTH
PRESSURIZATION VERSUS ROLLING

ELONGATION

The main experimental data are listed in Table 3 in order of increasing elongation to failure. (As shown below, some additional data were taken to supplement the data in Table 3; because they serve an auxiliary function, they will be listed separately.) Table 3 contains 25 entries of which the nine most ductile entries are all pressure crystallized. These nine entries represent six unique combinations of independent variables (ingots #32 and #43 replicate ingot #42, while #36T and #36B are from the top and bottom of the same ingot). This set of the most-ductile ingots represents every combination of melt and mold temperatures. The set also includes both rolled and unrolled ingots. What the ingots have in common is that they are all pressure crystallized. The increased ductility under a wide variety of conditions is the most convincing argument

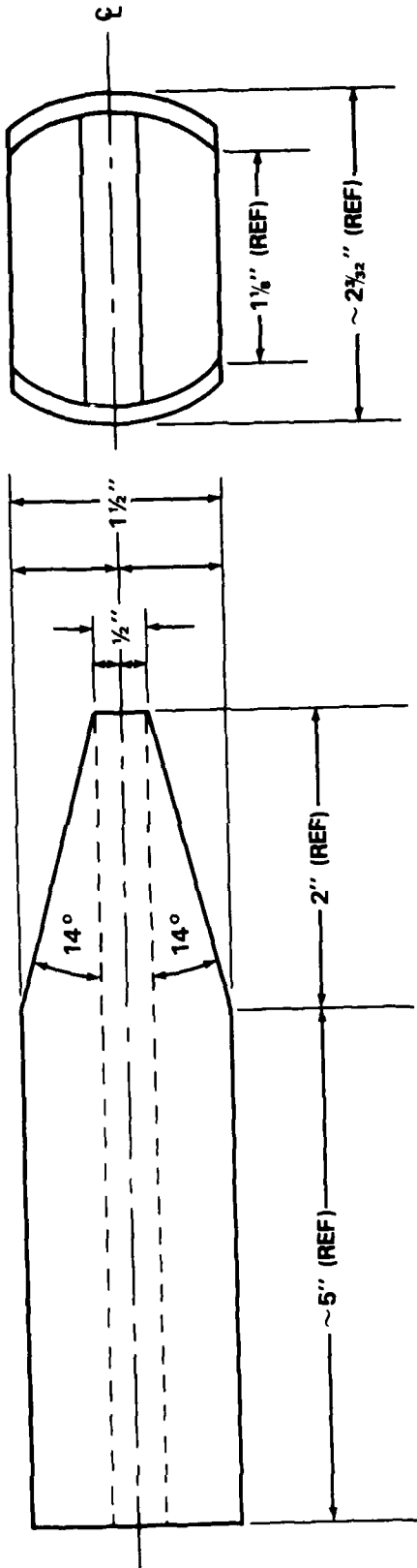

FIGURE 2. INGOT MACHINED FOR ROLLING

DISTRIBUTION

	<u>Copies</u>		<u>Copies</u>
Commander Naval Sea Systems Command Attn: SEA 05R25 (Dr. Vanderveldt)	1	ARCO, Inc. Attn: Jack Cooke Silag Operations Greer, SC 29651	1
SEA 05M2 (C. Hull)	1		
SEA 05MP (CDR Ryan Sack)	1	Consolidated Aluminum Attn: Philip R. Sperry	1
Washington, DC 20362		11960 Westline Industrial Dr. St. Louis, MO 63141	
Commander David Taylor Naval Ship R&D Center		Reynolds Metals Company Attn: Richard F. Ashton	1
Attn: Code 28	1	4th and Canal Streets P.O. Box 27003 Richmond, VA 23261	
Code 2803	1		
Code 2803 (R. R. Hardy)	1	Martin Marietta Laboratories Attn: Technical Library	1
Code 2801	1	1450 South Rolling Road Baltimore, MD 21227	
Code 281	1		
Code 2812	1	Boeing Aerospace Co. Attn: Tom Bosworth	1
Code 2813	1	Org. 2-2621 Mail Stop 1F-75 P.O. Box 3999 Seattle, WA 98124	
Code 2813 (Aylor)	1		
Code 2814	1		
Code 2815	1		
Annapolis, MD 21402			
Defense Technical Information Center			
Cameron Station			
Alexandria, VA 22314	12		
Library of Congress Attn: Gift and Exchange Div.	4	AiResearch Attn: Edwin Hodge	1
Washington, DC 20540		19800 Van Ness Avenue Torrance, CA 90509	
General Dynamics Electric Boat Division		Internal Distribution:	
Attn: Technical Library	1	E35 (GiDEP Office)	1
Groton, CT		E431	9
		E432	3
Wisconsin Centrifugal		R30	2
Attn: Jack Meinhardt	1	R32	1
P.O. Box 827		R32 (DeJarnette)	20
Waukesha, WI 53187		R32 (Divecha)	5
		R32 (Karmarkar)	5
		R32 (Willard)	5

END

FILMED

5-85

DTIC