

AD-R153 014

THE TOUCH PANEL SYSTEM; DESIGN AND DEVELOPMENT(U) ROME
AIR DEVELOPMENT CENTER GRIFFISS AFB NY M J VALENTINE
DEC 84 RADC-TR-84-258

1/1

UNCLASSIFIED

F/G 9/2

NL



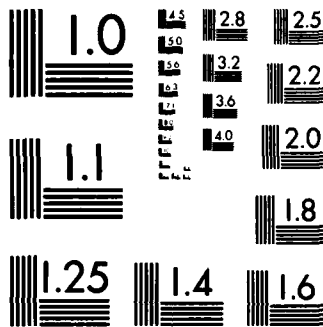

MICROCOPY RESOLUTION TEST CHART
NATIONAL BUREAU OF STANDARDS-1963-A

(2)

RADC-TR-84-258
In-House Report
December 1984



THE TOUCH PANEL SYSTEM; DESIGN AND DEVELOPMENT

Michael J. Valentine

AD-A153 014

APPROVED FOR PUBLIC RELEASE; DISTRIBUTION UNLIMITED

DTIC
ELECTE
APR 30 1985
S **D**
B

ROME AIR DEVELOPMENT CENTER
Air Force Systems Command
Griffiss Air Force Base, NY 13441-5700

DTIC FILE COPY

85 4 1985

This report has been reviewed by the RADC Public Affairs Office (PA) and is releasable to the National Technical Information Service (NTIS). At NTIS it will be releasable to the general public, including foreign nations.

RADC-TR-84-258 has been reviewed and is approved for publication.

APPROVED:



GEORGE R. HUGHES
Assistant Chief, Image Systems Branch
Intelligence & Reconnaissance Division

APPROVED:

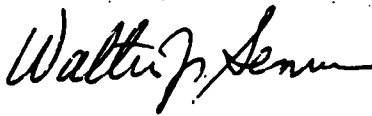

WALTER J. SENUS
Technical Director
Intelligence & Reconnaissance Division

FOR THE COMMANDER:



DONALD A. BRANTINGHAM
Plans Office

If your address has changed or if you wish to be removed from the RADC mailing list, or if the addressee is no longer employed by your organization, please notify RADC (IRRE) Griffiss AFB NY 13441-5700. This will assist us in maintaining a current mailing list.

Do not return copies of this report unless contractual obligations or notices on a specific document requires that it be returned.

AD-A153014

UNCLASSIFIED

SECURITY CLASSIFICATION OF THIS PAGE

REPORT DOCUMENTATION PAGE

1a. REPORT SECURITY CLASSIFICATION UNCLASSIFIED		1b. RESTRICTIVE MARKINGS N/A		
2a. SECURITY CLASSIFICATION AUTHORITY N/A		3. DISTRIBUTION/AVAILABILITY OF REPORT Approved for public release; distribution unlimited.		
2b. DECLASSIFICATION/DOWNGRADING SCHEDULE N/A				
4. PERFORMING ORGANIZATION REPORT NUMBER(S) RADC-TR-84-258		5. MONITORING ORGANIZATION REPORT NUMBER(S) N/A		
6a. NAME OF PERFORMING ORGANIZATION Rome Air Development Center	6b. OFFICE SYMBOL (If applicable) IRRE	7a. NAME OF MONITORING ORGANIZATION Rome Air Development Center (IRRE)		
6c. ADDRESS (City, State and ZIP Code) Griffiss AFB NY 13441-5700		7b. ADDRESS (City, State and ZIP Code) Griffiss AFB NY 13441-5700		
8a. NAME OF FUNDING/SPONSORING ORGANIZATION Rome Air Development Center	8b. OFFICE SYMBOL (If applicable) IRRE	9. PROCUREMENT INSTRUMENT IDENTIFICATION NUMBER N/A		
8c. ADDRESS (City, State and ZIP Code) Griffiss AFB NY 13441-5700		10. SOURCE OF FUNDING NOS.		
		PROGRAM ELEMENT NO. 62702F	PROJECT NO. 4594	TASK NO. 18
11. TITLE (Include Security Classification) THE TOUCH PANEL SYSTEM; DESIGN AND DEVELOPMENT				
12. PERSONAL AUTHOR(S) Michael J. Valentine				
13a. TYPE OF REPORT In-House	13b. TIME COVERED FROM May 84 to Aug 84	14. DATE OF REPORT (Yr., Mo., Day) December 1984	15. PAGE COUNT 24	
16. SUPPLEMENTARY NOTATION N/A				
17. COSATI CODES		18. SUBJECT TERMS (Continue on reverse if necessary and identify by block number) Touch Panel Ambient Light Phototransistor Interface Voltage Detector		
FIELD	GROUP			SUB. GR.
05	08			
09	02			
19. ABSTRACT (Continue on reverse if necessary and identify by block number) The computer keyboard can sometimes be difficult to use, especially with the number of different types that are manufactured. The touch panel concept eliminates the need for a keyboard to use a computer. The touch-panel works on a light-sensor idea whereby breaking a beam of light causes an entry to be made into the computer. It is much easier than having to type the entries on a keyboard. This report is a summary of the design and development of the touch-panel system during the summer of 1984. Included in this report are the system interface design, physical characteristics and electrical circuitry.				
20. DISTRIBUTION/AVAILABILITY OF ABSTRACT UNCLASSIFIED/UNLIMITED <input checked="" type="checkbox"/> SAME AS RPT <input type="checkbox"/> DTIC USERS <input type="checkbox"/>		21. ABSTRACT SECURITY CLASSIFICATION UNCLASSIFIED		
22a. NAME OF RESPONSIBLE INDIVIDUAL ANDREW R. PIRICH		22b. TELEPHONE NUMBER (Include Area Code) (315) 330-3175	22c. OFFICE SYMBOL RADC (IRRE)	

UNCLASSIFIED

SECURITY CLASSIFICATION OF THIS PAGE

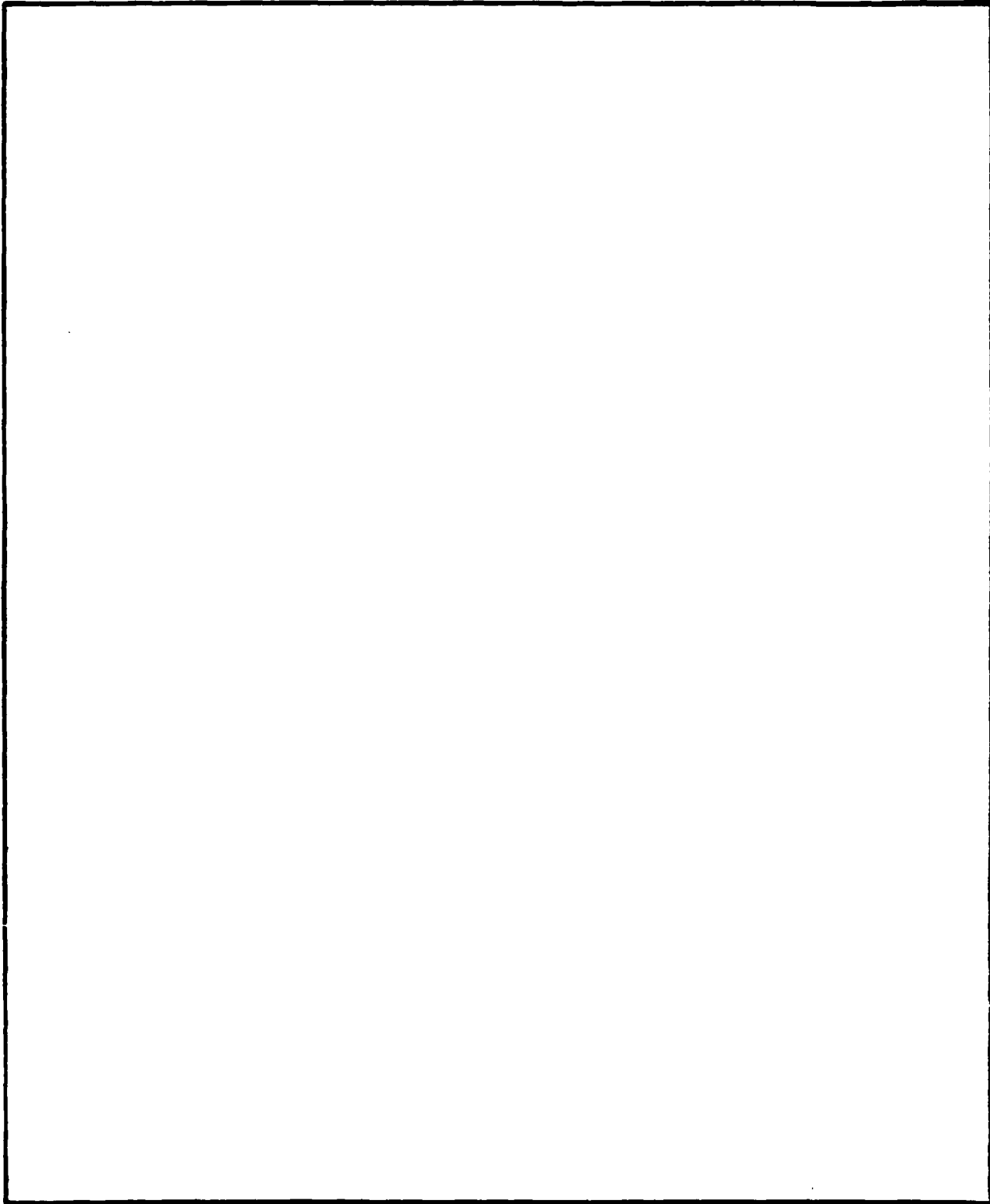

UNCLASSIFIED

SECURITY CLASSIFICATION OF THIS PAGE

TABLE OF CONTENTS

	<u>PAGE</u>
I - INTRODUCTION	1
II - PROTOTYPE SYSTEM DEVELOPMENT	3
III - SYSTEM CONFIGURATION	3
IV - ELECTRICAL COMPONENTS	5
V - AMBIENT LIGHT AND TEMPERATURE	7
VI - USING THE SYSTEM	8
VII - SYSTEM INTERFACE	9
VIII - CONCLUSION AND SUMMARY	11
IX - REFERENCES	12

LIST OF FIGURES

<u>TITLE</u>	<u>PAGE</u>
Figure 1A - Touch Panel Box Dimensions	2
Figure 1 - Touch Panel Circuit and Matrix	4
Figure 2A - Phototransistor-LED Pair	6
Figure 2B - Voltage Detector	6
Figure 3 - System Interface	11

LIST OF TABLES

TABLE 1 - SPOT NUMBER CODES

I. INTRODUCTION

The programmable switch array detection and selection system, commonly referred to as a touch-panel, is an alternate way of entering data and instructions into a computer. The operator communicates with the host computer by breaking beams of light. Depending on the beams that are broken, the data is input to the host system and the appropriate sequence of events takes place.

The need for such a system is evident where speed and accuracy of entering data and instructions are important.

Instructions and data are input to the system by touching a spot on the monitor screen with a stylus or finger. A light plane is situated just in front of the screen. (Figure-1A). Touching a spot on the screen breaks the light beam which generates a code that is ingested into the computer. It is important to remember that this is not the same as a heat sensor touch-panel system which is currently available on some computers.

TOUCH PANEL BOX DIMENSIONS

(Not To Scale - Dimensions in inches)

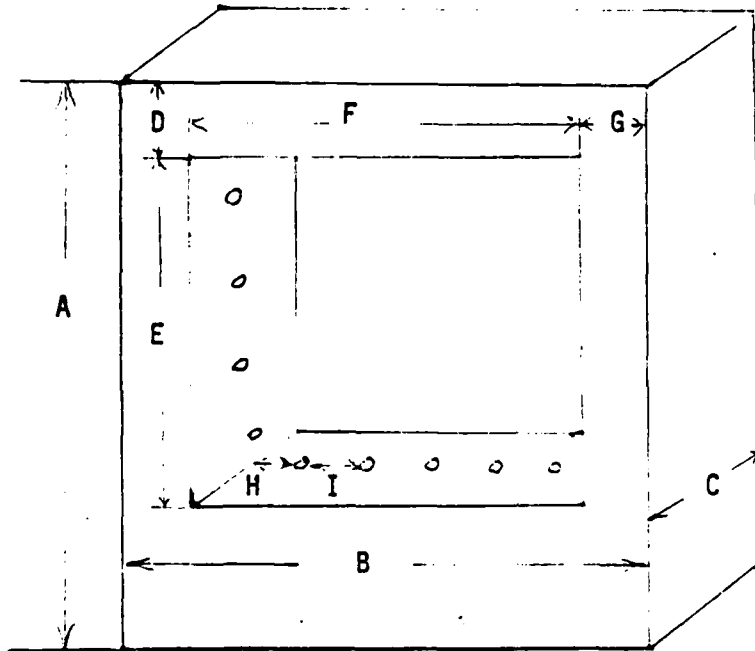

FIGURE 1A

A - 10.75

B - 11.5

C - 2.375

D - 1.25

E - 6.0

F - 8.25

G - 1.625

H - 1.0

I - 1.25

II. PROTOTYPE SYSTEM DEVELOPMENT

The first step in the development was determining the minimum spacing between LED- phototransistor pairs for maximum resolution. This was determined by placing components at various spacings and observing the output voltage on the emitter. A spacing of 1.25 inches between LEDs and phototransistors gave the best results.

A number of different circuits were tried before the voltage detector was selected (Figures 1, 2). Other circuits designed were not adjustable and were insensitive to the changes in the phototransistor emitter voltage.

The prototype model was constructed out of heavy cardboard (Figure 1A). The entire box was covered with flat black tape to minimize reflection of light. The touch panel system was tested under different parametric conditions:

- a. Sensitive spots were mapped and checked several times to determine proper voltage within the detectors.
- b. Different colors were displayed on the monitor to determine sensitivity effects of changing wavelengths of light.
- c. Demonstration software program was written and debugged.

After undergoing the above, the touch panel system was determined to be functional.

III. SYSTEM CONFIGURATION

The touch panel is configured like a box or window frame that fits against the monitor screen. The touch panel system was designed specifically for a ten inch (diagonal) monitor and is butted against the monitor screen.

The light emitting diodes (LED) are used as the transmitters and the photosensitive transistors act as receivers. The arrangement of LEDs and phototransistors form a matrix (Figure 1) of light beams just above

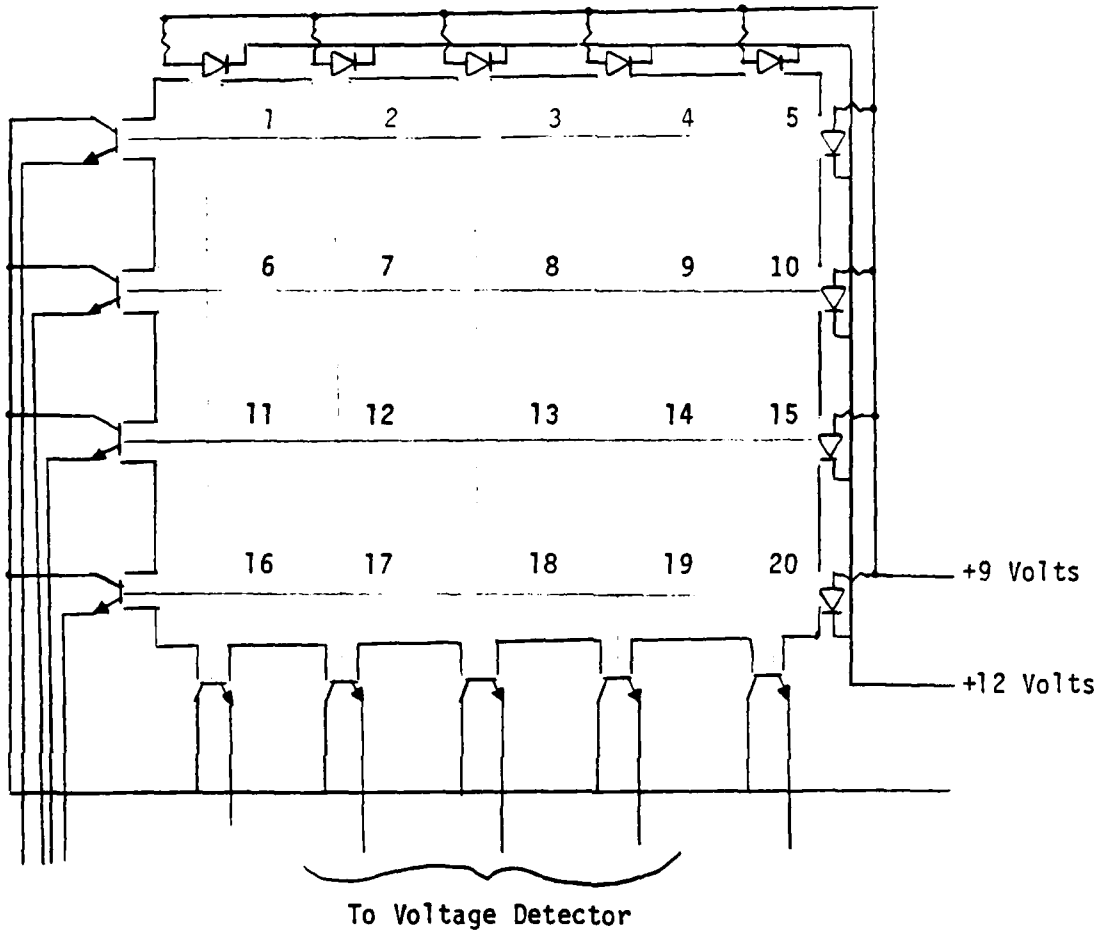

Touch-Panel Circuit and Matrix

Figure 1

the monitor screen. This matrix forms the basis for the touch panel. On the touch panel there are twenty intersections of the beams, which are called spots.

The matrix is formed from four LEDs on one side of the window and phototransistors on the opposite side of the window. There are five LEDs on the top with the corresponding five phototransistors on the bottom (Figure 1). The LEDs are mounted flush with the surface. The phototransistors are recessed into the surface of the window about one inch to minimize the effects of the ambient light. There are also openings in the box for wiring and access to the monitor control panel. Between adjacent components, there is a space of about 1.25 inches. This spacing was determined to give the best resolution with a minimum amount of interference between the light beams. The box has outside dimensions of 10.75 x 11.5 x 2.375 inches. There is a 6.0 x 8.25 inch opening in the box for the monitor screen. The above dimensions are for the prototype model (Figure-1A). This could easily be changed depending on the size and type of monitor.

IV. ELECTRICAL COMPONENTS

There are three basic circuits that are combined to make the electrical system for the touch panel: The phototransistor-light emitting diode circuit, the voltage detector, and the interface.

The phototransistor-LED pair is the receiver-transmitter section of the touch panel. The phototransistors are the receive portion of the touch panel and have their maximum response when the incident light has a wavelength of 900 nanometers; the wavelength of red light. The phototransistor and LED

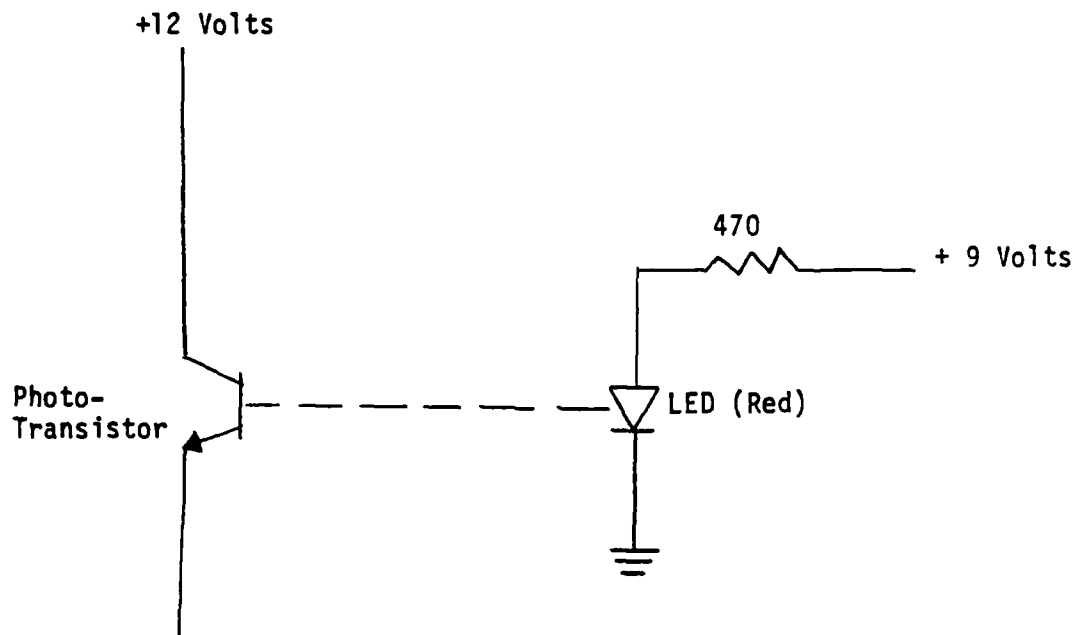

FIGURE 2A Phototransistor - LED Pair

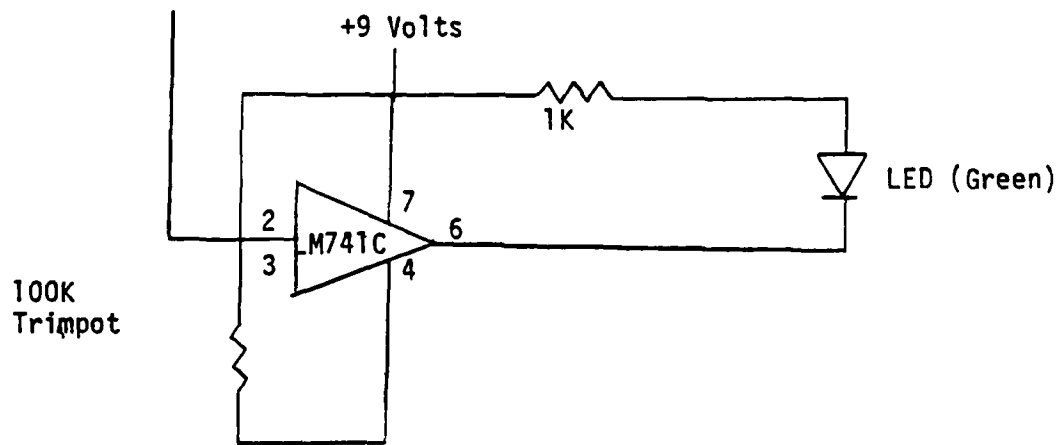

FIGURE 2B Voltage Detector

FIGURE 2

circuits are shown in Figure 2A. There are nine such circuits which form the matrix touch panel. (A full circuit diagram showing all the electrical connections and circuits for the touch panel is illustrated in Figure 1).

Another major component of the touch panel system is the voltage detector (Figure 2B). The circuit is connected to the emitter of the phototransistor. The 100 K-ohm trimming-potentiometer (trimpot) is used to set the minimum threshold voltage for the system. When the emitter voltage of the phototransistor is low, due to a light beam being broken, the threshold voltage is not reached and the LED fails to glow. The voltage detector is very sensitive and requires precise adjustments of the trimpots to the proper threshold voltage. However, once the trimpots are adjusted, they will remain so; provided the ambient light conditions and temperature remain relatively constant.

The LM741 operational amplifier is the major component of the touch panel system. The LED used emits green light to minimize the amount of ambient red light.

V. AMBIENT LIGHT AND TEMPERATURE

Ambient light conditions played a key role in the design and development of the touch panel system. This is the major reason for the phototransistor having to be recessed into the sides of the window. The prototype model was built in a laboratory environment where the amount of light can be controlled. A problem

was the monitor screen, which is a major source of light. The color red should be avoided with monitor displays. Black, blue and yellow displays were used for testing and evaluation. These colors do have some effect on the phototransistors, but it is compensated for when the voltage detectors are adjusted.

Temperature did not play a very significant role in the system design. Since several integrated circuits are used, the room temperature should be within the operating range, which is about -55°C to 85°C . The trim pots are sensitive to temperature. A wide fluctuation in temperature will significantly affect the resistivity of the circuit element. An operating temperature of approximately 20°C is suggested.

VI. USING THE SYSTEM

After the power has been turned on, the system must be initialized. The first step in this process is booting the host computer and displaying either the first menu or instructions. Next, the operator checks the circuitry to be sure that the voltage detectors are properly adjusted.

The menu is a combination of graphics and text. There are twenty spots displayed on the monitor which correspond to the intersection of two light beams on the touch panel. Near the spot, which is actually a box drawn on the monitor screen, there is a number or a brief description of the spot function. Touching the box on the screen causes the light beams to be interrupted. The operator must be sure to place his finger on the box at a right (90°) angle in order to break the proper light beams.

The spots performed a variety of functions, such as: graphics demonstrations, exit the system, enter the text mode for keyboard entries

and a new/next menu function. A "help" spot was also implemented in case an operator was not familiar with the system or encountered difficulty. Of course, the functions will vary depending on the use of the system.

VII. SYSTEM INTERFACE

In order for data and instructions to be entered into the computer, there are a variety of handshake signals that must be active at the input port. When the appropriate signals are transmitted the data is input into the computer. The data that is input to the computer is an eight bit binary code. The code is generated when a spot is touched. (In theory the input data should be a nine bit quantity; since this is an unusual number, the most significant bit was left off, resulting in an eight bit quantity). A list of the spot numbers and their equivalent code are shown in Table 1.

The prototype system (touch panel) interface was developed according to the Electronics Industry Association (EIA) RS232 serial interface specifications. The interface can be modified to conform to different host computers.

The prototype system (touch panel) interface is illustrated in Figure 3. This design incorporates the necessary handshake signals necessary to input the touch panel code into the computer. The eight bit data is sent to a buffer and then to a parallel-to-serial shift register. The serial data is then ready to be input into the computer. There are two other signals that must be used to input data; the "Data Set Ready" signal from the touch panel and the "Clear to Send" input from the Shift/Register. These signals represent the handshake signals necessary for the data to be sent to the host computer.

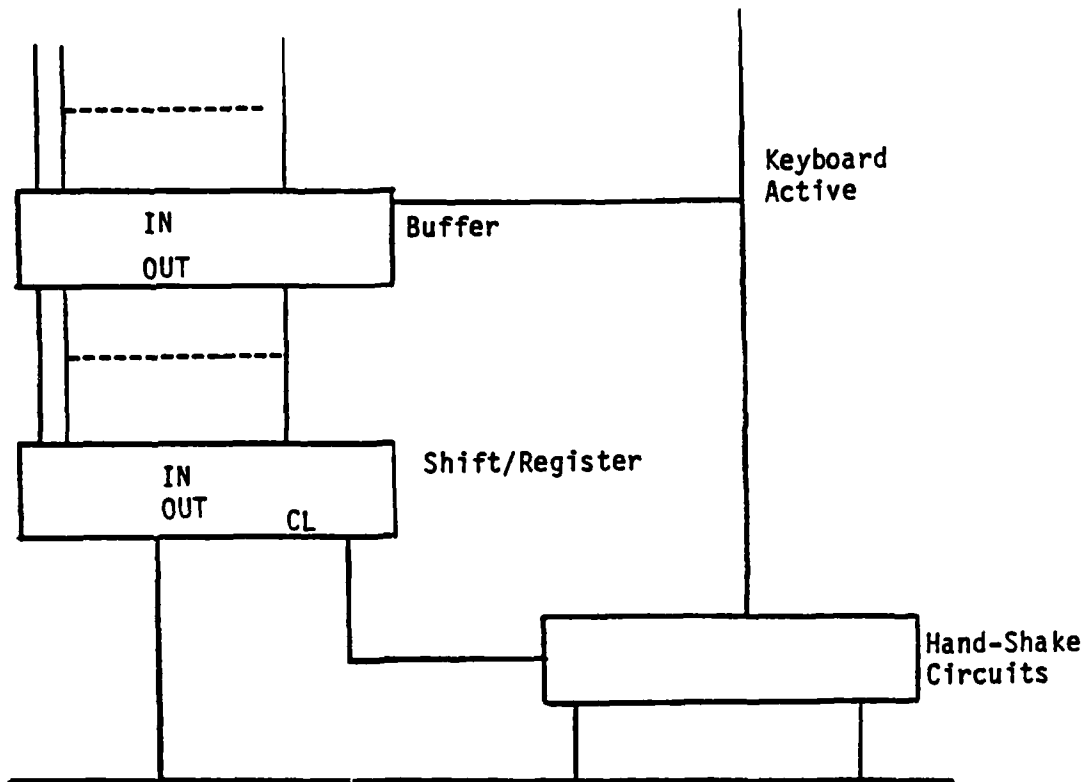

Touch-Panel System Interface

Figure-3

Once the data is input to the computer, the system software takes over. The program analyzes the received data and performs the operations that correspond to the entered information. When the operation is complete, the appropriate results or information are displayed, as well as prompts requesting the next operation.

VIII. CONCLUSION AND SUMMARY

The touch-panel system provides a viable alternative to a keyboard as a method of inputting data and instructions to a computer. The system is best suited for a dedicated set-up where once the programs are running, all the user must do to perform different functions is to touch one of the light-sensitive spots. Applications for the system include control systems, information processing and access devices, such as directories.

IX. REFERENCES

1. Forest M. Mims III, Engineers Notebook - Integrated Circuit Applications
Radio Shack - Tandy Corporation, 1979.
2. IBM Technical Reference, IBM Corporation Boca Raton, Florida, 1983.

TABLE 1
Spot Number Codes

<u>Spot Number</u> (From Figure 1)	<u>Binary Code</u> (8 Bit)	<u>Hex</u> <u>Representation</u>
1	11110111	F7
2	11111011	FB
3	11111101	FD
4	11111110	FE
5	01110111	77
6	01111011	7B
7	01111101	7D
8	01111110	7E
9	10110111	B7
10	10111011	BB
11	10111101	BD
12	10111110	BE
13	11010111	D7
14	11011011	DB
15	11011110	DD
16	11011101	DE
17	11100111	E7
18	11101011	EB
19	11101101	ED
20	11101110	EE



*MISSION
of
Rome Air Development Center*

RADC plans and executes research, development, test and selected acquisition programs in support of Command, Control Communications and Intelligence (C³I) activities. Technical and engineering support within areas of technical competence is provided to ESD Program Offices (POs) and other ESD elements. The principal technical mission areas are communications, electromagnetic guidance and control, surveillance of ground and aerospace objects, intelligence data collection and handling, information system technology, solid state sciences, electromagnetics and electronic reliability, maintainability and compatibility.

END

FILMED

5-85

DTIC