

AD-A153 073

RAREFACTION WAVE ELIMINATOR CONCEPTS FOR A LARGE  
BLAST/THERMAL SIMULATOR. (U) ARMY BALLISTIC RESEARCH  
LAB ABERDEEN PROVING GROUND MD C N KINGERY ET AL.

1/1

UNCLASSIFIED

FEB 85 SBI-AD-F300 595 BRL-TR-2634

F/G 1974

NL

END

FILMED

DTIC

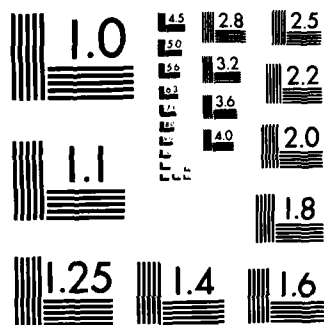

MICROCOPY RESOLUTION TEST CHART  
NATIONAL BUREAU OF STANDARDS-1963-A

(2)

AD

**B  
R  
L**

TECHNICAL REPORT BRL-TR-2634

AD-A153 073

**RAREFACTION WAVE ELIMINATOR CONCEPTS  
FOR A LARGE BLAST/THERMAL SIMULATOR**

Charles N. Kingery  
George A. Coulter

February 1985

**DTIC**  
**ELECTE**  
**APR 16 1985**  
**S**  
**B**

APPROVED FOR PUBLIC RELEASE; DISTRIBUTION UNLIMITED.

**US ARMY BALLISTIC RESEARCH LABORATORY  
ABERDEEN PROVING GROUND, MARYLAND**

DTIC FILE COPY

Destroy this report when it is no longer needed.  
Do not return it to the originator.

Additional copies of this report may be obtained  
from the National Technical Information Service,  
U. S. Department of Commerce, Springfield, Virginia  
22161.

The findings in this report are not to be construed as an official  
Department of the Army position, unless so designated by other  
authorized documents.

The use of trade names or manufacturers' names in this report  
does not constitute indorsement of any commercial product.

UNCLASSIFIED

SECURITY CLASSIFICATION OF THIS PAGE (When Data Entered)

REPORT DOCUMENTATION PAGE		READ INSTRUCTIONS BEFORE COMPLETING FORM
1. REPORT NUMBER TECHNICAL REPORT BRL-TR-2634	2. GOVT ACCESSION NO. ADA153 073	3. RECIPIENT'S CATALOG NUMBER
4. TITLE (and Subtitle) RAREFACTION WAVE ELIMINATOR CONCEPTS FOR A LARGE BLAST/THERMAL SIMULATOR		5. TYPE OF REPORT & PERIOD COVERED Final
		6. PERFORMING ORG. REPORT NUMBER
7. AUTHOR(s) Charles N. Kingery George A. Coulter		8. CONTRACT OR GRANT NUMBER(s)
9. PERFORMING ORGANIZATION NAME AND ADDRESS US Army Ballistic Research Laboratory ATTN: AMXBR-TBD Aberdeen Proving Ground, MD 21005-5066		10. PROGRAM ELEMENT, PROJECT, TASK AREA & WORK UNIT NUMBERS Task Code G55 AMXGR Work Unit 00016
11. CONTROLLING OFFICE NAME AND ADDRESS US Army Ballistic Research Laboratory ATTN: AMXBR-OD-ST Aberdeen Proving Ground, MD 21005-5066		12. REPORT DATE February 1985
14. MONITORING AGENCY NAME & ADDRESS (if different from Controlling Office)		13. NUMBER OF PAGES 60
		15. SECURITY CLASS. (of this report) UNCLASSIFIED
		15a. DECLASSIFICATION/DOWNGRADING SCHEDULE
16. DISTRIBUTION STATEMENT (of this Report)  Approved for public release; distribution unlimited.		
17. DISTRIBUTION STATEMENT (of the abstract entered in Block 20, if different from Report)		
18. SUPPLEMENTARY NOTES		
19. KEY WORDS (Continue on reverse side if necessary and identify by block number) Blast Effects                      LB/TS                      Shock Tube Blast Simulator                      Overpressure                      Simulator/Blast Blast Wave                      Rarefaction Wave Eliminator		
20. ABSTRACT (Continue on reverse side if necessary and identify by block number) Several design concepts for rarefaction wave eliminators were tested on a 1/285th scale model shock tube. The most promising concepts - vented plate and multiple vented bars - were tried at larger scales on the BRL 0.57 and 2.44 metre shock tubes. Either of these two designs is believed to be acceptable for use on a large blast/thermal simulator.		

DD FORM 1473 EDITION OF 1 NOV 65 IS OBSOLETE

UNCLASSIFIED

SECURITY CLASSIFICATION OF THIS PAGE (When Data Entered)

TABLE OF CONTENTS

	Page
LIST OF ILLUSTRATIONS . . . . .	5
I. INTRODUCTION . . . . .	7
A. Background . . . . .	7
B. Objectives . . . . .	7
II. EXPERIMENT . . . . .	7
A. Modified 5.08 cm Inside Diameter Shock Tube . . . . .	7
B. Instrumentation . . . . .	10
C. Types of Rarefaction Wave Eliminators Tested . . . . .	10
III. RESULTS . . . . .	10
A. Requirement for a RWE . . . . .	10
B. Test Station Results with an Ideal RWE . . . . .	14
C. Test Station Results with a Solid Plate RWE . . . . .	21
D. Test Station Results with a Foam Plate RWE . . . . .	21
E. Test Station Results with a Vented Foam Plate RWE . . . . .	26
F. Test Station Results with a Multiple Bar RWE . . . . .	26
G. Test Station Results with Other Types of RWE's . . . . .	33
IV. RESULTS OF LARGER SCALE TESTS . . . . .	37
A. Test Section Results from 0.57 Metre Shock Tube . . . . .	37
B. Test Section Results from 2.44 Metre Shock Tube . . . . .	45
V. ANALYSIS OF RESULTS . . . . .	45
A. Vented Area versus Test Station Pressure . . . . .	45
B. Direct Comparison of RWE Concepts . . . . .	45
VI. CONCLUSIONS AND RECOMMENDATIONS . . . . .	48
LIST OF REFERENCES . . . . .	54
DISTRIBUTION LIST . . . . .	55

## LIST OF ILLUSTRATIONS

Figure	Page
1. Planned Concept for the US-LB/TS . . . . .	8
2. Modified 5.08 cm Inside Diameter Shock Tube . . . . .	9
3. Schematic of Data Acquisition-Reduction System . . . . .	11
4. Overpressure Versus Time in a Long Shock Tube . . . . .	13
5. Pressures at Station 4L . . . . .	16
6. Overpressure Versus Time at Stations 1, 2, and 3, 50 kPa, without an RWE . . . . .	18
7. Overpressure Versus Time at Stations 1 through 4, 50 kPa, Long Tube without an RWE . . . . .	19
8. Overpressure Versus Time at Station 2, Input Pressures, 20, 50, 100, and 150 kPa, Long Tube without an RWE . . . . .	20
9. RWE Concepts . . . . .	22
10. Solid Plate RWE, 50kPa Input Pressure . . . . .	24
11. Solid Plate RWE, Station 2, Input Pressures 20, 50, 100, and 150 kPa . . . . .	25
12. Foam Plate RWE, 50 kPa Input Pressure . . . . .	27
13. Foam Plate RWE, Station 2, Input Pressures 20, 50, 100, and 150 kPa . . . . .	28
14. Vented Foam Plate RWE, 50 kPa Input Pressure . . . . .	29
15. Vented Foam Plate RWE, Station 2, Input Pressures 20, 50, 100, and 150 kPa . . . . .	30
16. Wave Diagram for 5.08 cm Shock Tube . . . . .	31
17. Multiple Bar RWE, 50 kPa Input Pressure . . . . .	32
18. Multiple Bar RWE, Station 2, Input Pressures 20, 50, 100, and 150 kPa . . . . .	34
19. Other RWE Concepts, 50 kPa Input Pressure . . . . .	35
20. Sketch of BRL 0.57 Metre Shock Tube . . . . .	38
21. RWE's for BRL 0.57 Metre Shock Tube . . . . .	39

LIST OF ILLUSTRATIONS (Continued)

Figure	Page
22. Pressure-Time Records, No RWE, 50 kPa Input Pressure, 0.57 Metre Shock Tube . . . . .	40
23. Pressure-Time Records, No RWE, 100 kPa Input Pressure, 0.57 Metre Shock Tube . . . . .	41
24. Pressure-Time Records, Vented Foam RWE, 50 kPa Input Pressure, 0.57 Metre Shock Tube . . . . .	42
25. Pressure-Time Records, Vented Foam RWE, 100 kPa Input Pressure, 0.57 Metre Shock Tube . . . . .	43
26. Pressure-Time Records, Multiple Bars RWE, Input Pressures 50 and 100 kPa . . . . .	44
27. Pressure-Time Records, Vented RWE, Input Pressures 35, 50, and 145 kPa, BRL 2.44 Metre Shock Tube . . . . .	46
28. Vent Area Ratio Versus Test Station Overpressure . . . . .	47
29. Dynamic Pressure Versus Time Comparisons . . . . .	49

S D

B

DTIC  
ELECTE  
APR 16 1985

Accession For	
NTIS GRA&I	<input checked="" type="checkbox"/>
DTIC TAB	<input type="checkbox"/>
Unannounced	<input type="checkbox"/>
Justification	
By	
Distribution/	
Availability Codes	
Dist	Avail and/or Special
A-1	



## I. INTRODUCTION

### A. Background

Testing was conducted at the BRL shock tube facilities from early 1950 through 1982 without rarefaction wave eliminators (RWE's) attached to the tubes. The 0.0508 metre and the 0.1016 metre tubes were usually tested with closed ends. In the 0.57 metre tube, the test section is upstream of the open end far enough that the rarefaction wave does not affect the overpressure versus time recorded in the test section.

Much of the past testing in the 2.44 metre shock tube has been against panels placed against the end of the tube or against targets where drag loading, or diffraction only, were of interest. Recently requirements have changed where both drag and diffraction loading are of interest. This established an interest in developing the engineering requirements for a RWE to be attached to the 2.44 metre shock tube.<sup>1</sup>

### B. Objectives

The objective of this research task is to use the 5.08 cm shock tube to design and test various types of RWE's suitable for a Large Blast/Thermal Simulator<sup>2</sup> (LB/TS). A second objective is to select the most promising type and test it on a larger shock tube to validate scaling factors.

## II. EXPERIMENT

### A. Modified 5.08 cm Inside Diameter Shock Tube

A 5.08 cm inside diameter shock tube was designed to represent a modified version of a planned US-LB/TS shown in Figure 1. The modified tube is a simplified 1/285th scale model shown in Figure 2C. The decaying wave is produced with baffles in the driver section<sup>3</sup> rather than with multiple pipes

---

<sup>1</sup> George A. Coulter, Gerald Bulmash, and Charles N. Kingery, "Experimental and Computational Modeling of Rarefaction Wave Eliminator Suitable for the BRL 2.44 m Shock Tube," Ballistic Research Laboratory Technical Report No. APPRL-TR-02503, June 1983 (AD #A131894).

<sup>2</sup> A. Cadet and J.B.G. Monzac, "Le Simulateur De Souffle a Grand Gabarit Du Centre D'Etudes De Gramat: Description et Utilisation Operationnelle," Seventh MABS Symposium, DRES, Canada, July 1981.

<sup>3</sup> George A. Coulter, Gerald Bulmash, and Charles Kingery, "Feasibility Study of Shock Wave Modification in the BRL 2.44 m Blast Simulator," Ballistic Research Laboratory Memorandum Report No. ARBRL-MR-03339, March 1984 (AD #A139631).

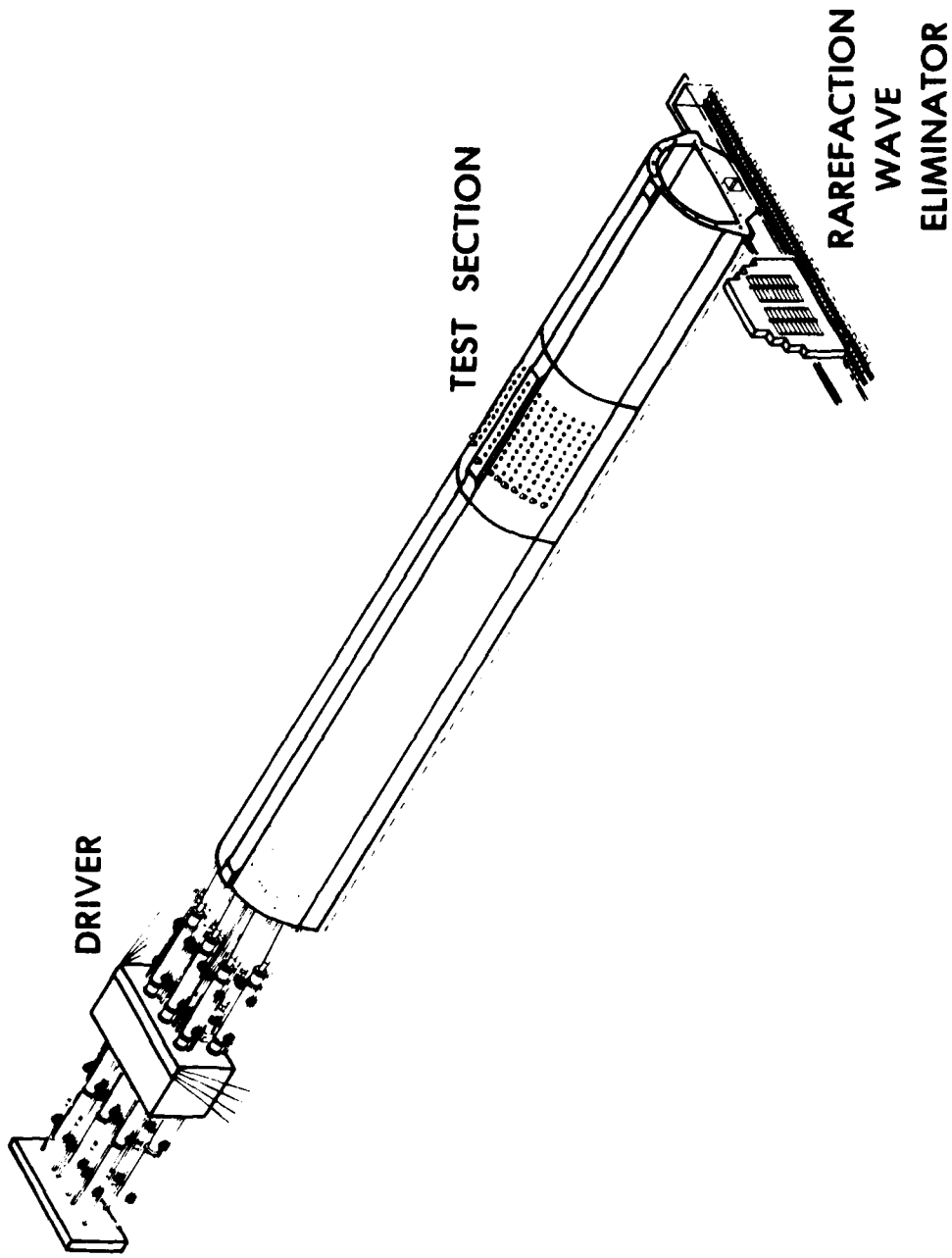
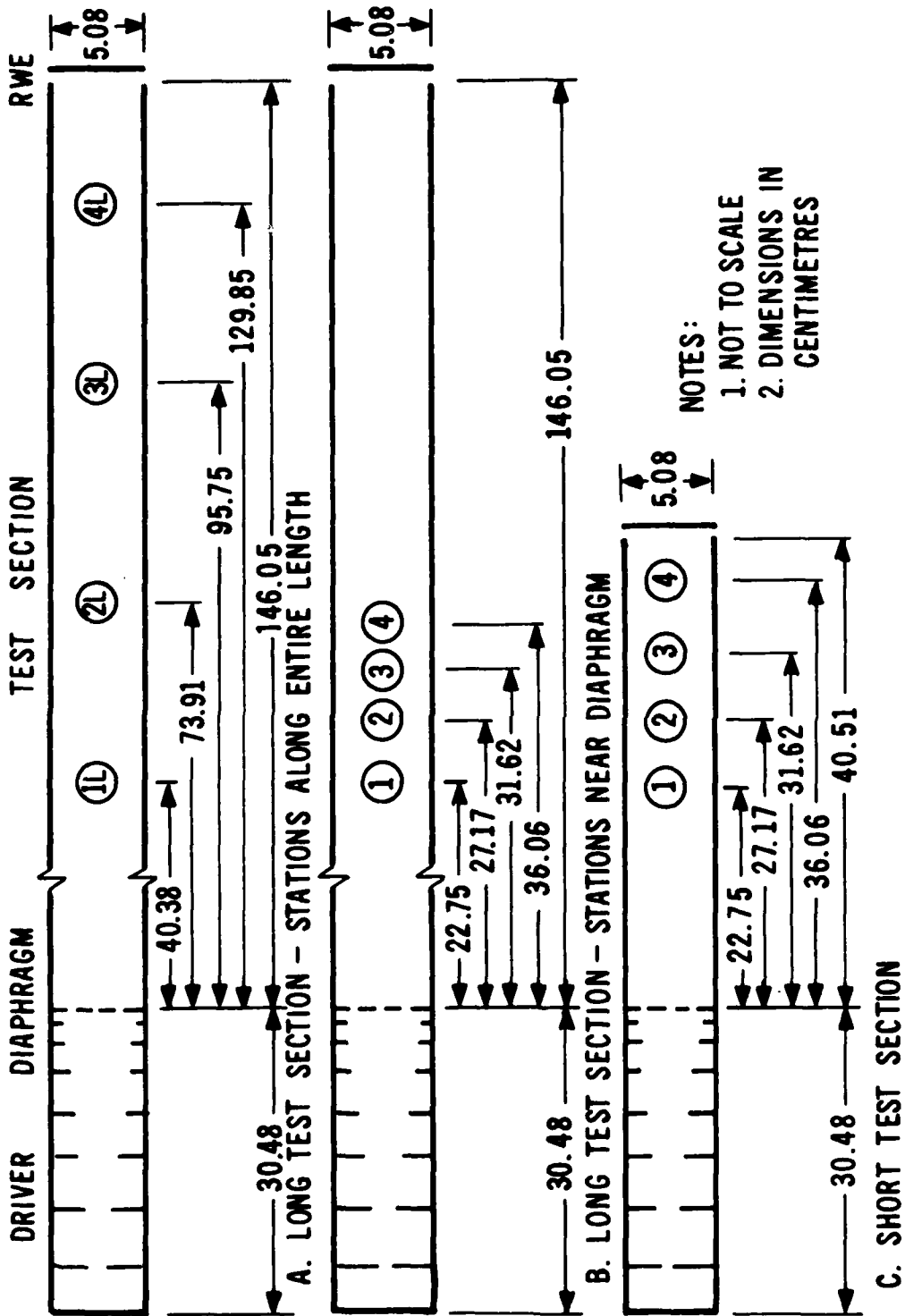

Figure 1. Planned Concept for the US-LB/TS



NOTES:  
 1. NOT TO SCALE  
 2. DIMENSIONS IN CENTIMETRES

Figure 2. Modified 5.08 cm Inside Diameter Shock Tube

of varying length. The test area is a circular cross section rather than a half-circle. The objective here is to use a shock tube with a fast turn-around time to study several candidate RWE's and determine the most feasible and practical design. The design must be capable of large scale construction and operation.

Four possible test areas were selected and instrumented, but during the early phase of testing, Station 4 was dropped from the program because it was too close to the end of the tube, making it difficult to produce an acceptable overpressure versus time record with the RWE. The effort was concentrated with side-on pressure transducers at Stations 1, 2, and 3. A stagnation pressure probe was also installed at Station 2 for some of the shots.

#### B. Instrumentation

A schematic of the data acquisition-reduction system is given in Figure 3. Quartz piezoelectric transducers were used in the shock tube test section to monitor the blast wave shape and interaction with the rarefaction wave eliminator. The results from the transducers were used to evaluate each modification of the RWE's.

The transducers were coupled through a power supply and data amplifiers, to a digitizing oscilloscope. On-site comparisons of the results were made directly from the hard copies of the pressure-time records. Final data processing was completed with the computer, printer, and plotter. Plots of pressure-time records for the various test stations are included for comparison of results obtained from each RWE.

#### C. Types of Rarefaction Wave Eliminators Tested

The objective of this program is to determine the feasibility of developing design requirements for a static rarefaction eliminator that would produce an acceptable overpressure versus time history at a selected test section. Therefore the effort was concentrated on various approaches and suggestions for a static RWE. It might be the most cost effective alternative to an active RWE such as is in operation at the Gramat facility in France. The various RWE concepts tested in the 5.08m shock tube are listed in Table 1. Four of the concepts listed in Table 1 were further tested again at peak overpressure range of 20 kPa to 150 kPa. The results over this range will be presented. Comparisons of pressure-time records obtained with each type will be made in the RESULTS section.

### III. RESULTS

#### A. Requirement for a RWE

The requirement for a rarefaction wave eliminator is a function of the length of the expansion section and the nearness of the test section to the open end of the tube. To show the effect of expansion length and station location, tests were conducted with a baffled driver and a long tube with four test stations. Stations 1L, 2L, 3L, and 4L (See Figure 2) were located 21, 14, 10, and 3 diameters from the open end of the tube. In Figure 4A the

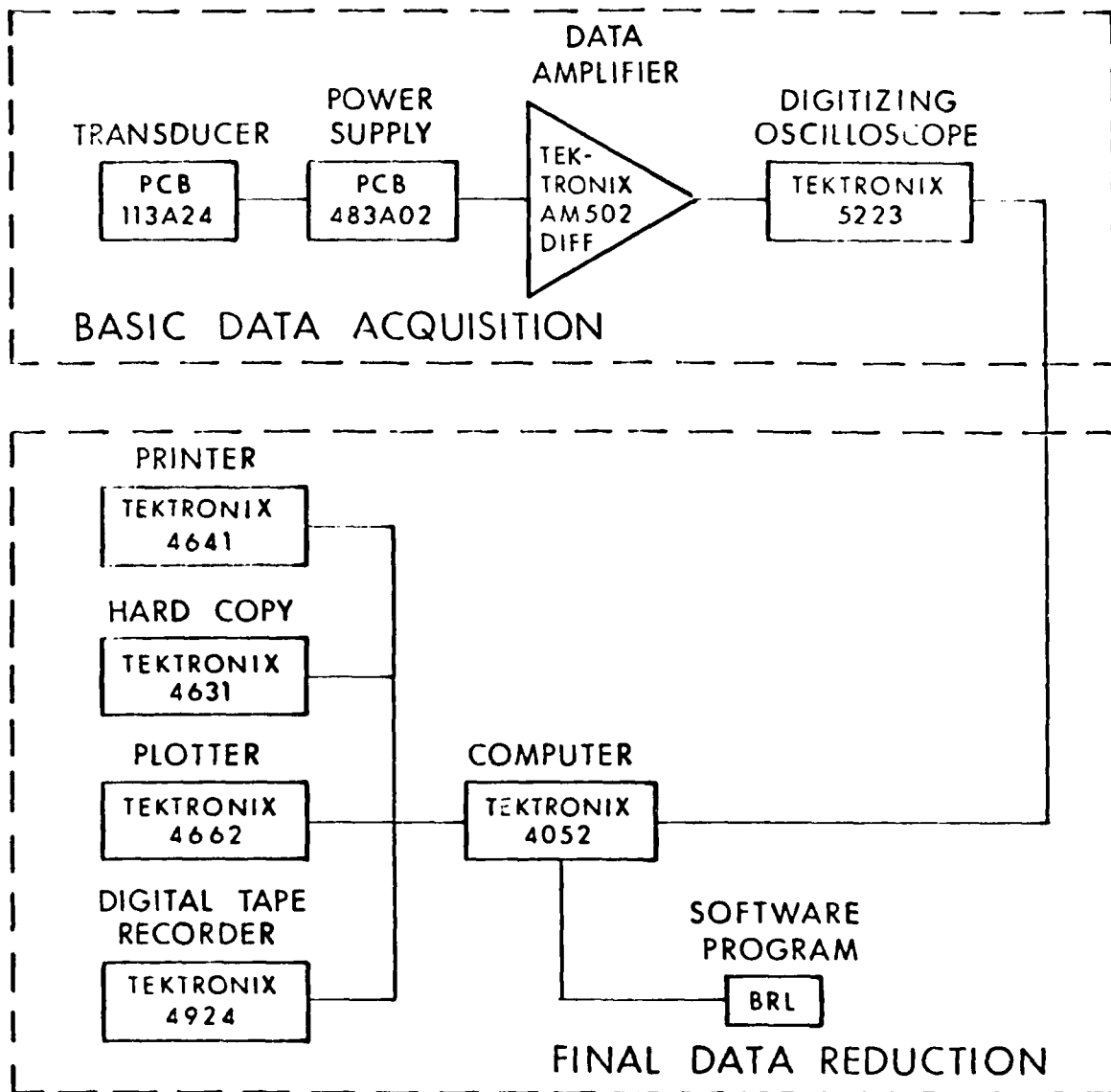





















Figure 3. Schematic of Data Acquisition-Reduction System

TABLE 1 RWE CONCEPTS TESTED

<u>ITEM No.</u>	<u>TYPE</u>	<u>ARRANGEMENT</u>	<u>WAVESHAPE</u>
1	FLAT PLATE		
2	FLAT PLATE / FOAM		
3	VENTED PLATE		
4	VENTED PLATE / FOAM		
5	BARS - MULTIPLE		
6	BARS - SINGLE		
7	NEEDLES		
8	PIPES		
9	SHARP EDGE SLOTS		
10	STEEL WOOL		

overpressure versus time is presented for Stations 1, 2, and 3 at an input pressure of 50 kPa. In Figure 12 it can be seen that the stand-off for the RWE is more efficient when tuned for a specific test station. On this test, it was tuned for Station 2; therefore Stations 1 and 3 were not matched as well.

In Figure 13 the overpressure versus time recorded at Station 2 for input pressures of 20, 50, 100, and 150 kPa are presented. The foam plate is more efficient at the lower input pressures (less than 100 kPa) than at the higher input pressures. A small rarefaction dip becomes more obvious as the input pressure is increased above the 100 kPa level.

#### E. Test Section Results with a Vented Foam Plate RWE

The vented foam plate concept is shown in Figure 9C. It is a combination of the vented plate tested in Reference 1 and the foam plate tested in this program. The overpressures versus time recorded at Stations 1, 2, and 3 are presented in Figure 14 for a 50 kPa input pressure. Here again the stand-off was set to match the reflected and rarefaction waves at Station 2.

The difficulty in matching the two waves at Station 2 for different input pressures is shown in Figure 15. When comparing the overpressure versus time presented in Figure 15 with those shown in Figure 13, it appears that the solid foam plate is the better RWE concept.

#### F. Test Section Results with a Multiple Bar RWE

The use of multiple bars rather than vented or perforated plates was presented in Reference 6. The concept was further tested and reported in Reference 7. Multiple bars were tested in this program as a feasible RWE concept. The bars were tested in a single plane but were found to be similar to a perforated plate. In order to have more control over the variables that govern the arrival of the reflected wave and the rarefaction wave at the test station, a second set of bars was introduced. The configuration of the bar RWE is shown in Figure 9D. There is a variable stand-off, a set of 5 bars, a fixed spacer and a set of variable bars. The simplified wave diagram in Figure 16 illustrates how the RWE parameters may be varied for a particular test station.

The overpressures versus time recorded at Station 1, 2, and 3 for a 50 kPa input pressure are presented in Figure 17. Here again the RWE was tuned for Station 2. In Figure 18 the overpressures versus time recorded at Station 2

---

<sup>6</sup> J.F. Procter, "Airblast Effects Simulation and Response, Part II of A Facility for Simulation of Thermal Radiation-Airblast Effects," Third MABS Symposium, Ernst Mach Institute, Freiburg, Germany, September 1972.

<sup>7</sup> I.C. Leys, "Model Scale Experiments for the Development of An Extension to the AWRE Foulness Nuclear Blast Simulator," Seventh MABS Symposium, DRES, Canada, July 1981.

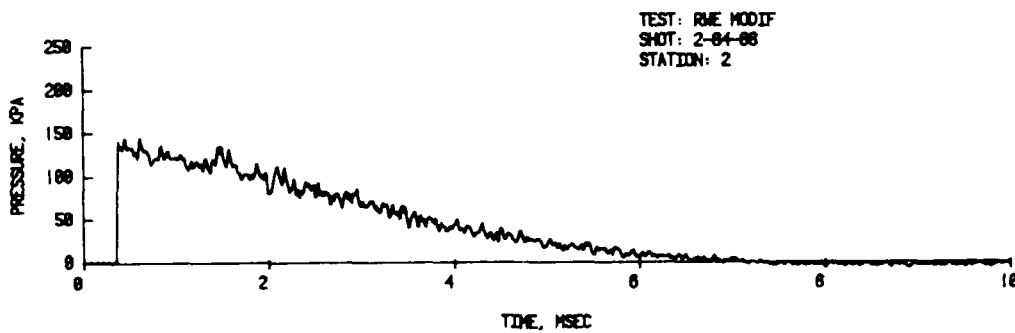
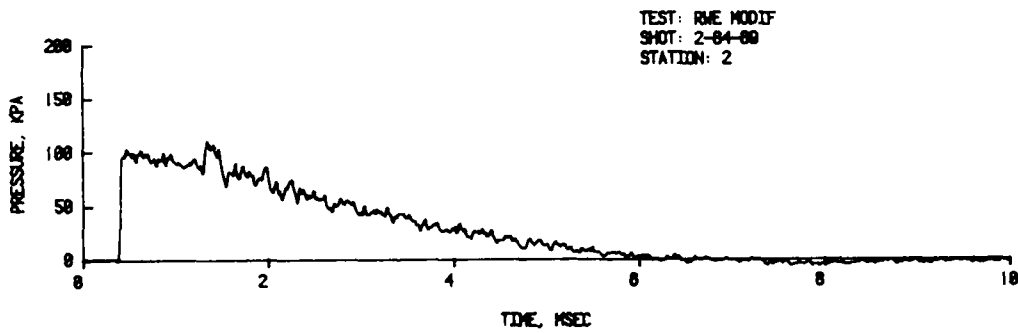
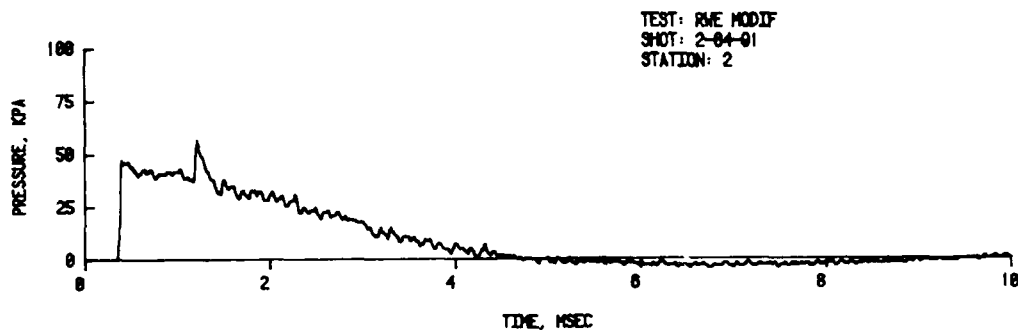
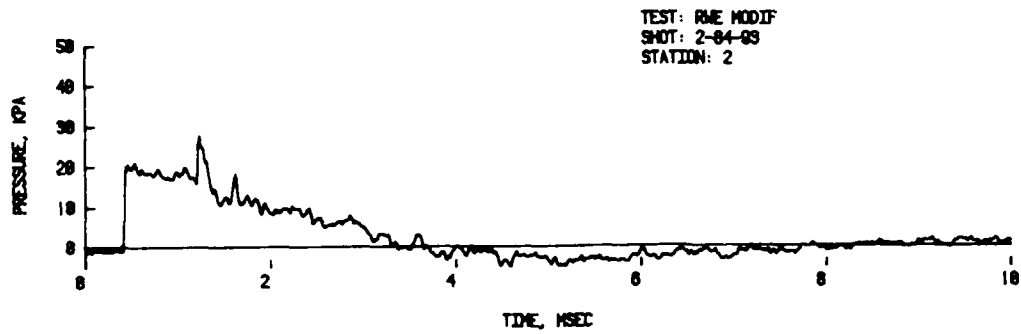

Figure 11. Solid Plate RWE, Station 2, Input Pressures 20, 50, 100 and 150 kPa

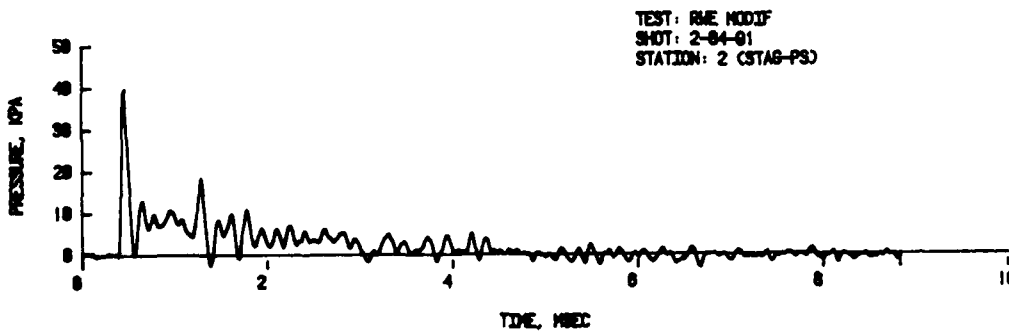
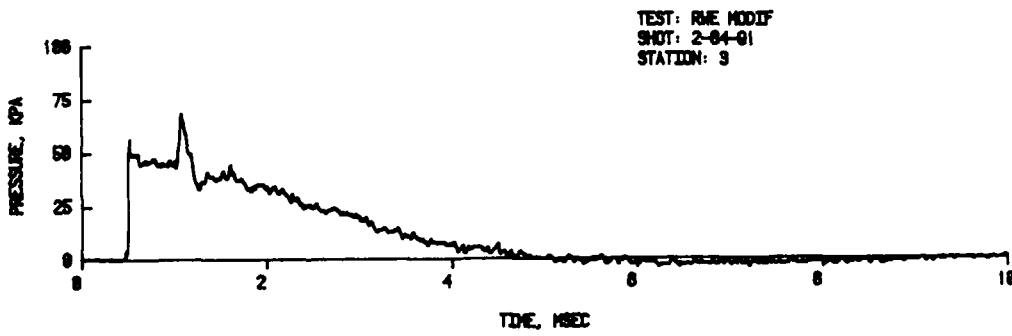
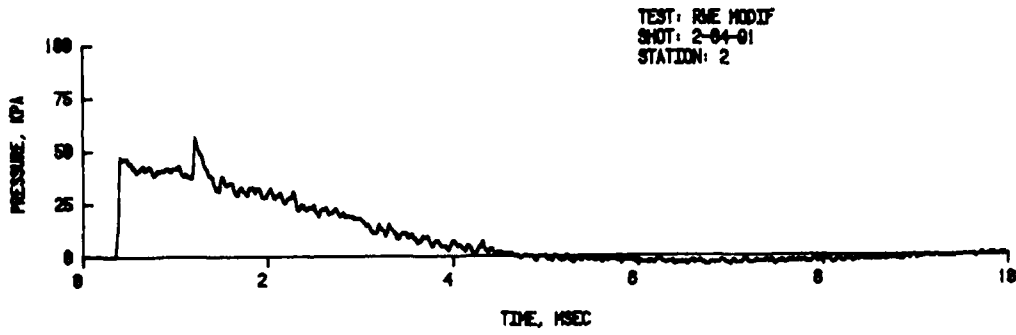
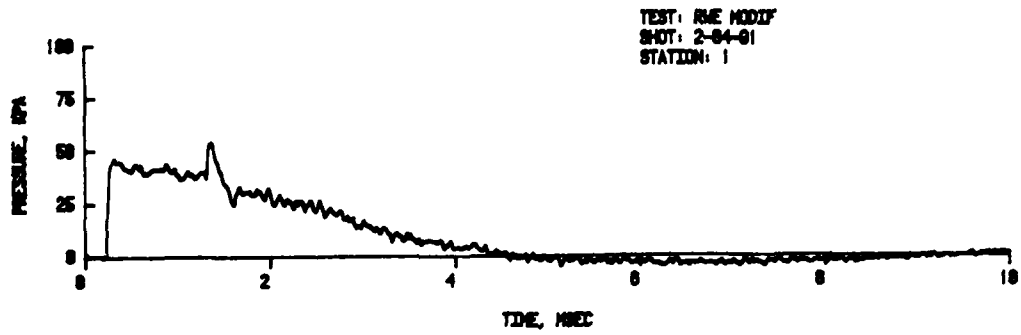
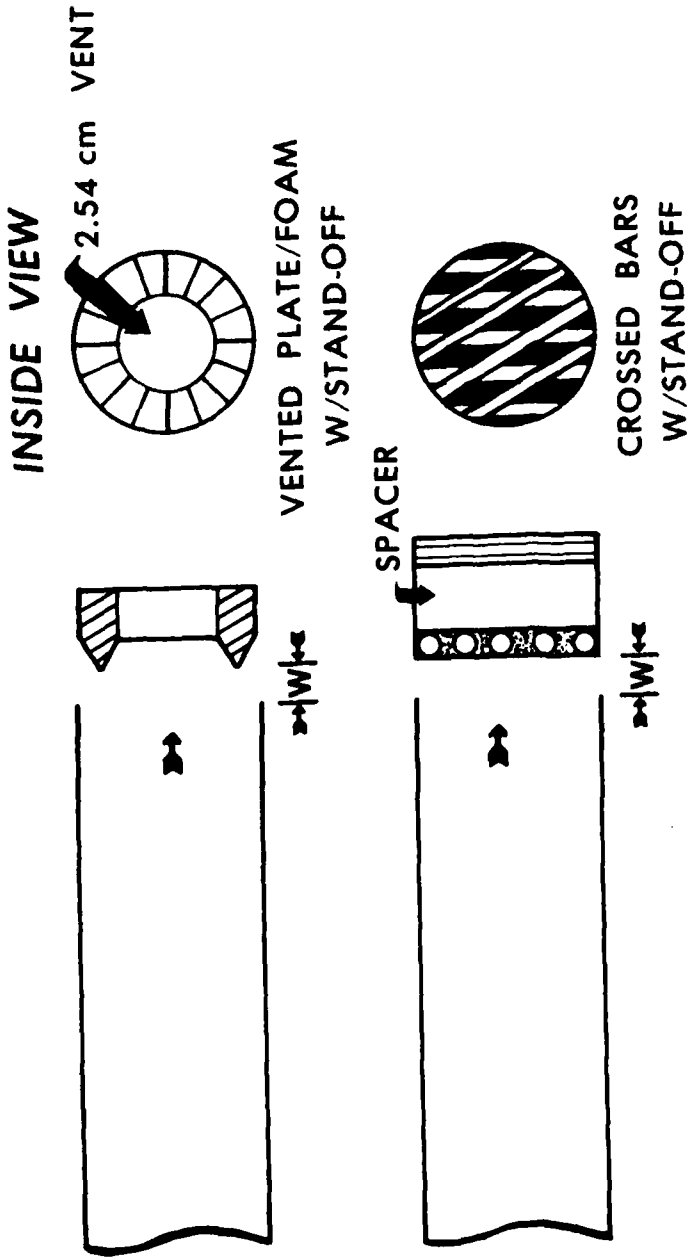

Figure 10. Solid Plate RWE, 50 kPa Input Pressure



- NOTES:**
- (1) NOT TO SCALE
  - (2) BARS ARE 0.237 cm DIAMETER

Figure 9. RWE Concepts (cont.)

INSIDE VIEW

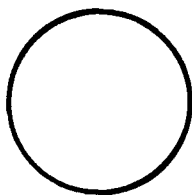

SOLID PLATE  
W/STAND-OFF

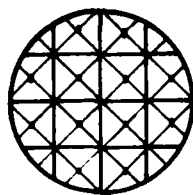

SOLID PLATE/FOAM  
W/STAND-OFF

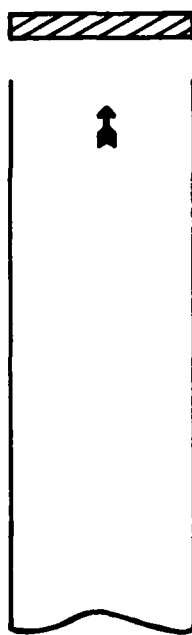

W

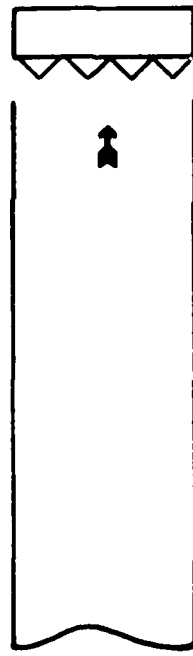

W

**NOTES:**

(1) NOT TO SCALE

(2) WAFFLED FOAM RUBBER IS 1.91 cm THICK

Figure 9. RWE Concepts

### C. Test Section Results with a Solid Plate RWE

The solid plate RWE is one of the four types tested extensively during this program. The details describing the four are shown in the sketches in Figure 9A. Some early work using a solid flat plate for a rarefaction wave eliminator was reported in Reference 4. In this reference, the stand-off and the vent area versus peak overpressure at the end of the tube were determined and equations were established. The stand-off and vented area ratios presented in Reference 4 do not match those established by the BRL in Reference 1. No explanation has been found other than the fact that the BRL work concentrated on eliminating the rarefaction effects closer to the open end of the shock tube and the input shock wave was a step or flat top shock wave.

The solid flat plate did not appear objectionable as a RWE in the reported results in Reference 1, where a flat top or step wave was generated from the long compression chamber. But when a decaying shock wave is generated and the stations are near the end of the tube, then Figure 10 demonstrates the difficulty in using a solid flat plate. There, the reflected shock wave exceeds the initial shock when the stand-off distance is matched for rarefaction wave elimination. In Figure 10 three stations are presented for one pressure level, while in Figure 11 the effect of the solid flat plate RWE is presented for four pressure levels at Station 2. As shown in Figure 11A, the elimination of the reflected wave and the rarefaction wave moving upstream is more difficult at the lower overpressures.

Note that the magnitude of the ratio of the initial peak to the reflected peak becomes less as the initial peak overpressure increases. It is less than 1.0 at the 150 kPa input pressure as shown in Figure 11D. At input pressures of 150 kPa and greater, the solid flat plate would be acceptable.

### D. Test Section Results with a Foam Plate RWE

The use of a polymethane foam rubber for attenuating the reflected pressure from the RWE was presented in Reference 5. The RWE designed for a 40 x 40 cm shock tube consisted of a package of iron wire grids, perforated plate, foam rubber, a second perforated plate, another layer of foam rubber (perforated), and then a final reflecting plate.

The foam plate RWE tested in this program consisted of a layer of polymethane foam material with the upstream side cut in a waffle design and the downstream side resting against a solid reflecting plate as shown in Figure 9B. The efficiency of the foam plate RWE is shown in Figure 12 where the

<sup>4</sup>George L. Rubin and Gerald Berman, "Reflection and Rarefaction Elimination in Shock Tubes," *Military Applications of Blast Simulators Symposium*, 1967, Canada, July 1967.

<sup>5</sup>W. van der Lugt, "Evaluation of a Reflection Eliminator for a 40 x 40 cm<sup>2</sup> Blast Simulator," *Prins Maurits Laboratorium, The Netherlands, INTRIM Report 58/78*, July 1981.

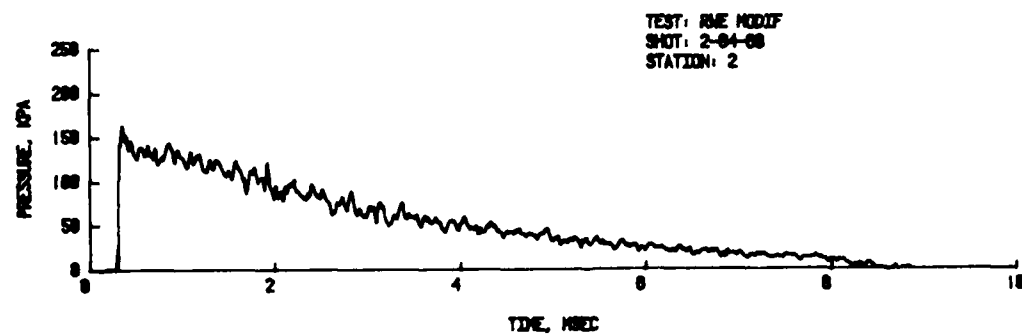
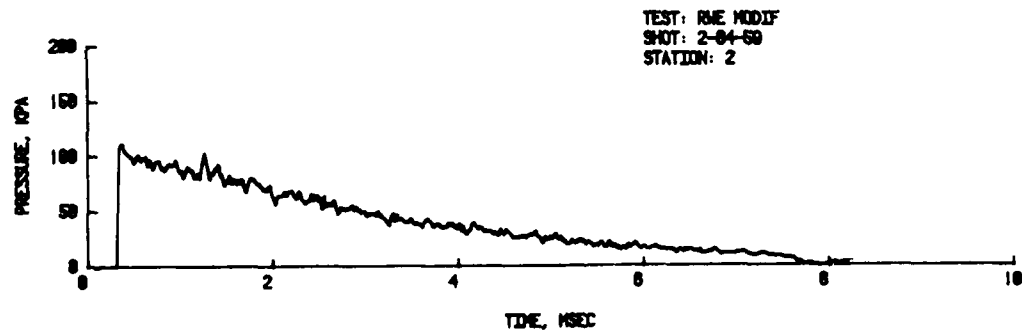
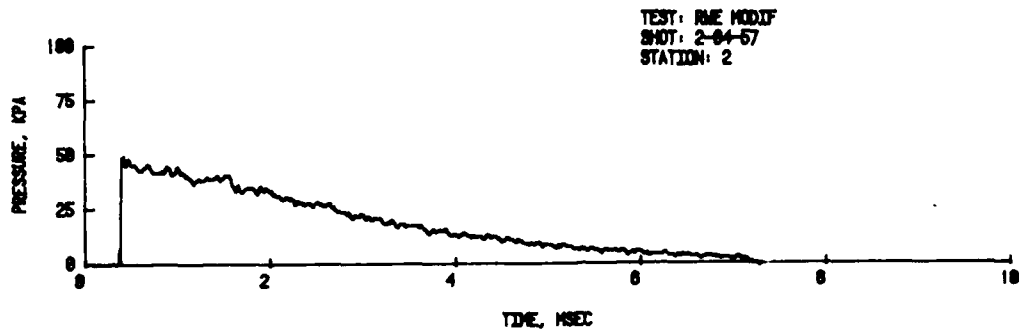
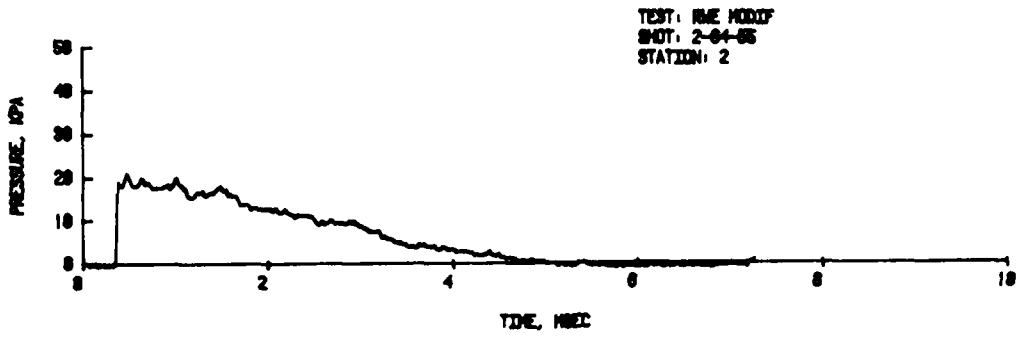

Figure 8. Overpressure Versus Time at Station 2, Input Pressures 20, 50, 100, and 150 kPa, Long Tube without an RWF

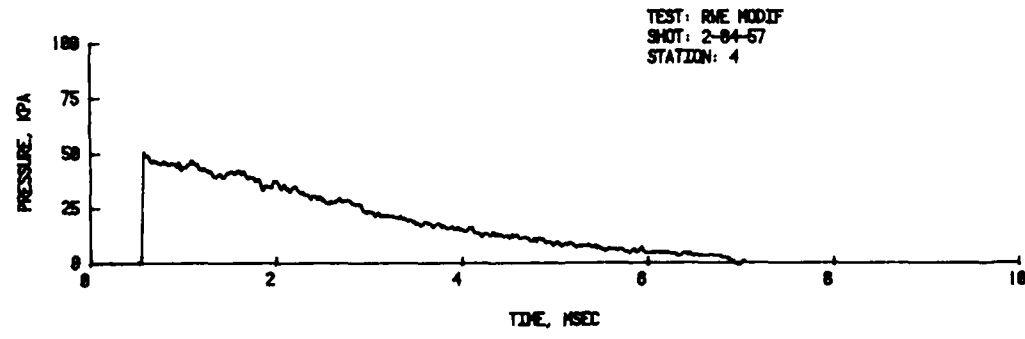
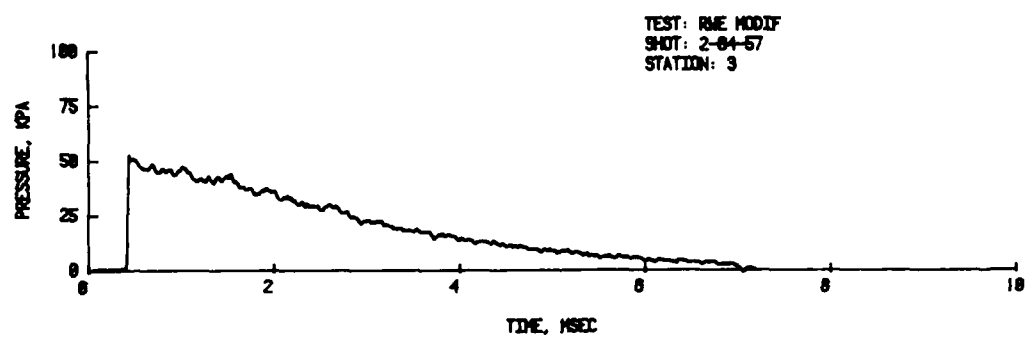
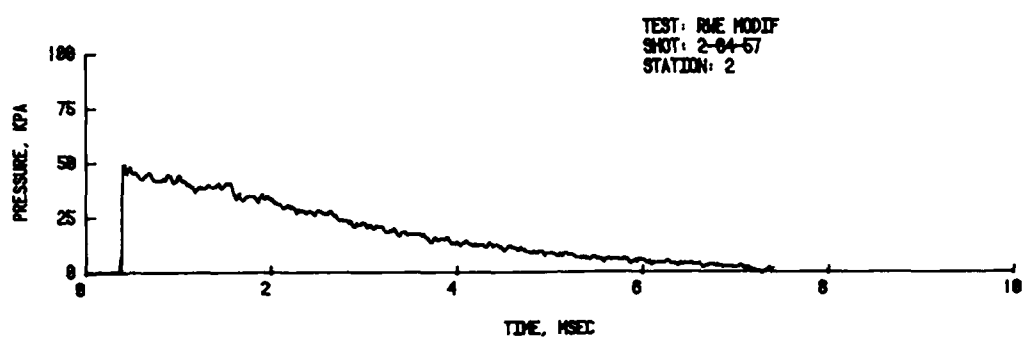
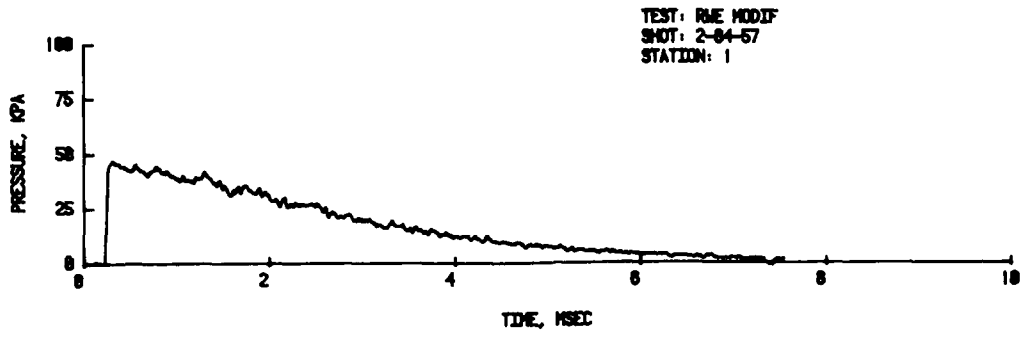

Figure 7. Overpressure Versus Time at Stations 1 through 4, 50 kPa, Long Tube without an RWE

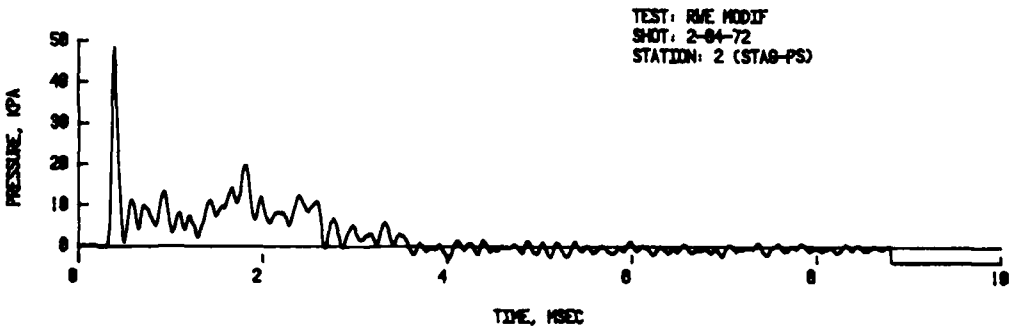
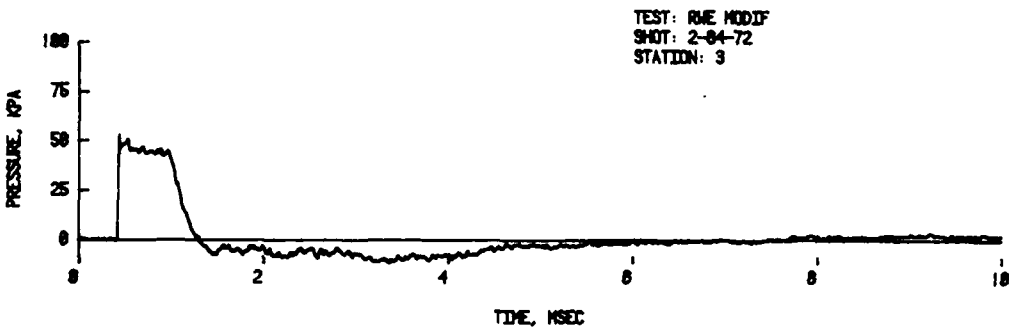
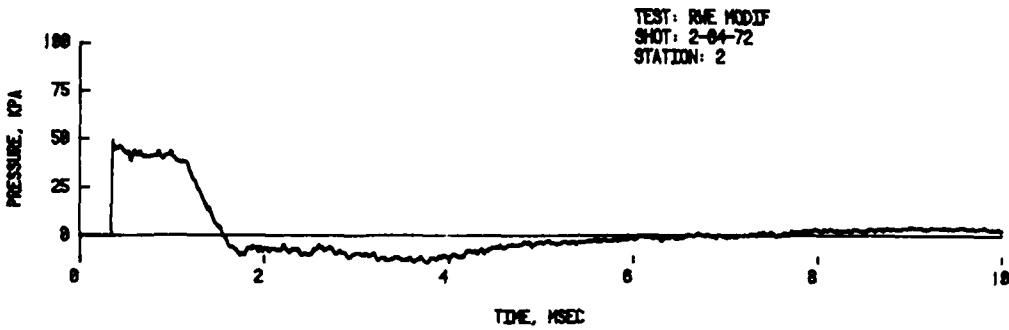
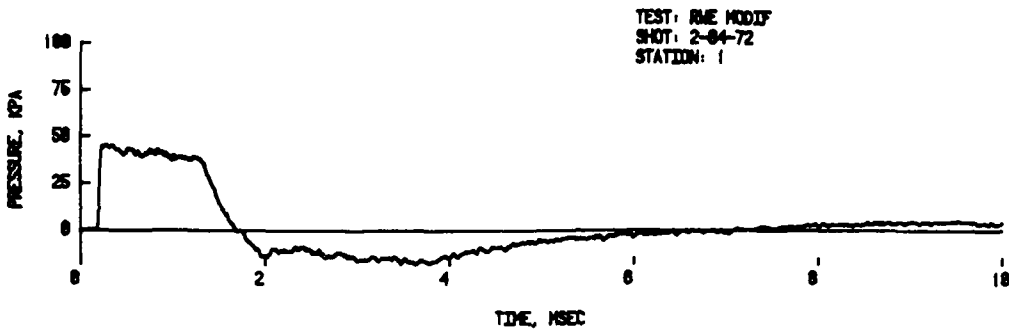
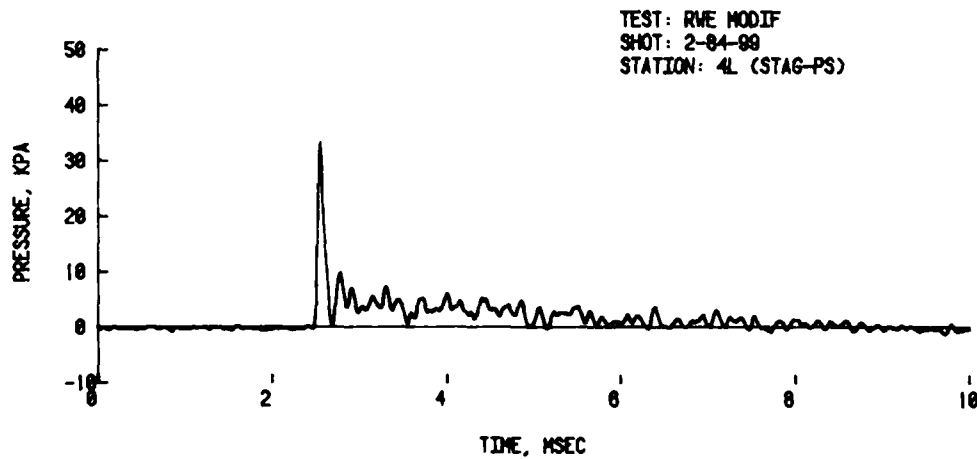
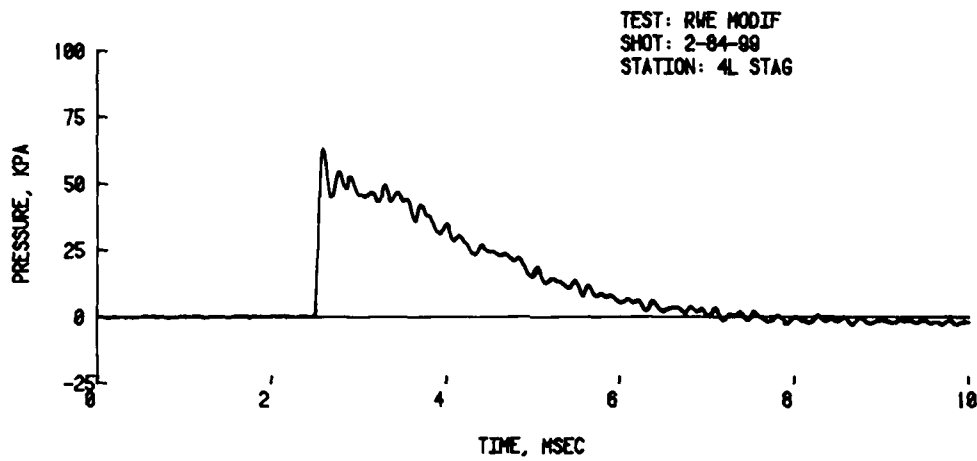
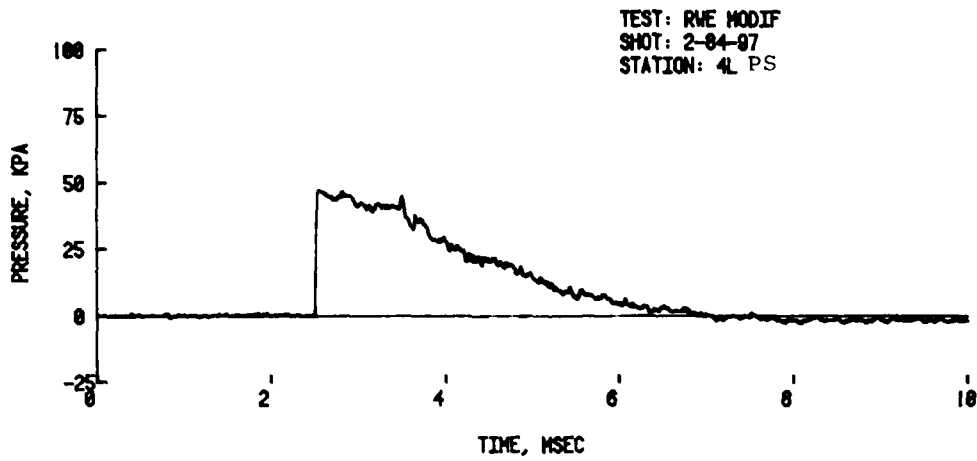
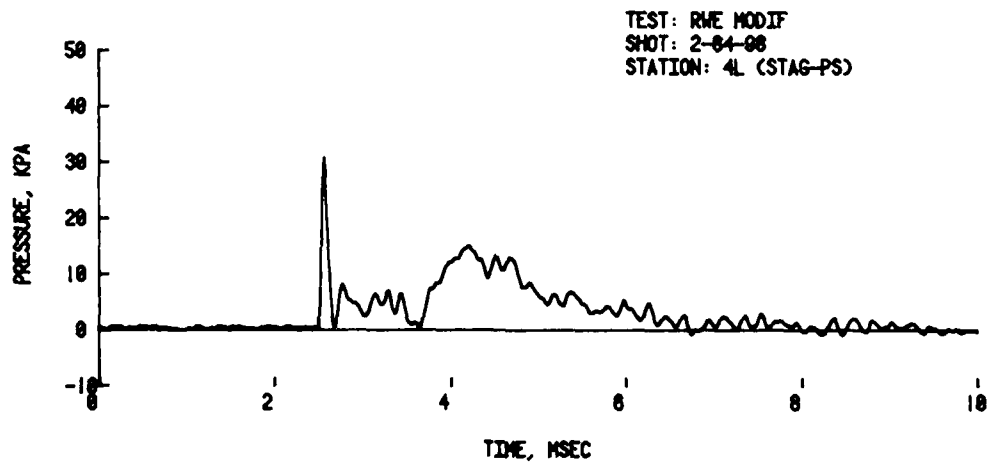
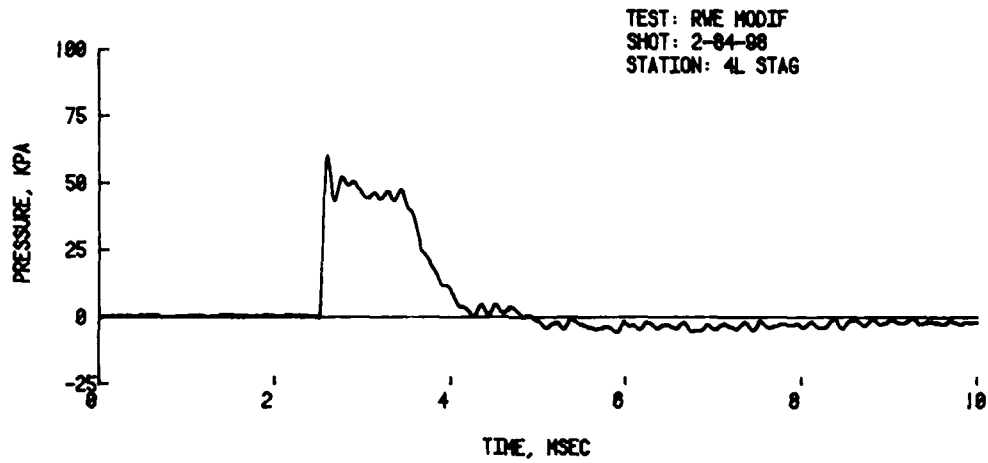
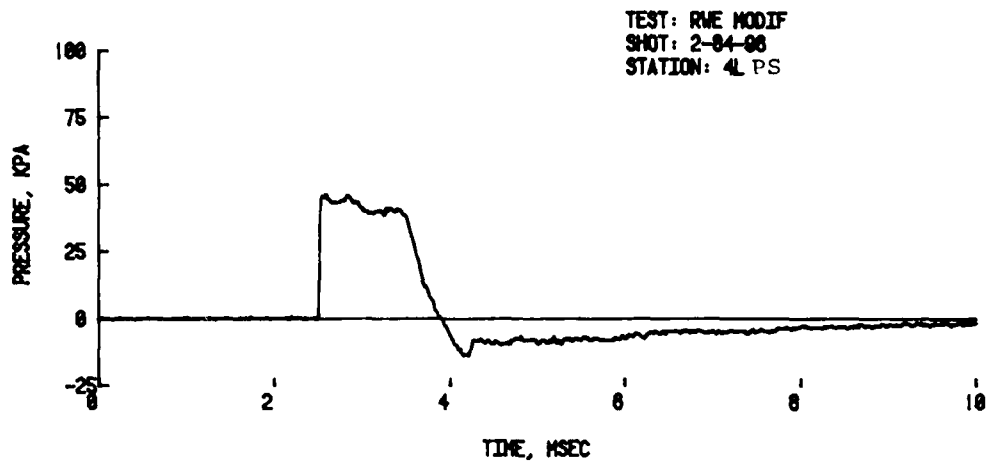

Figure 6. Overpressure Versus Time at Stations 1,2, and 3, 50 kPa, without an RWE



B. WITH RVE

Figure 5. Pressures at Station 4L. (cont)



A. NO RWE

Figure 5. Pressures at Station 4L

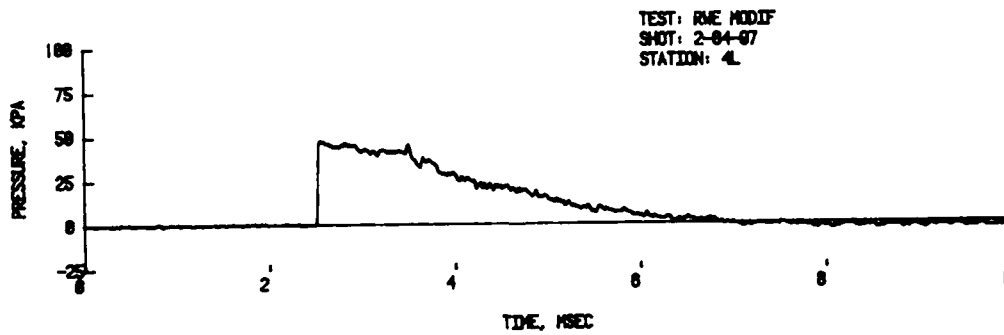
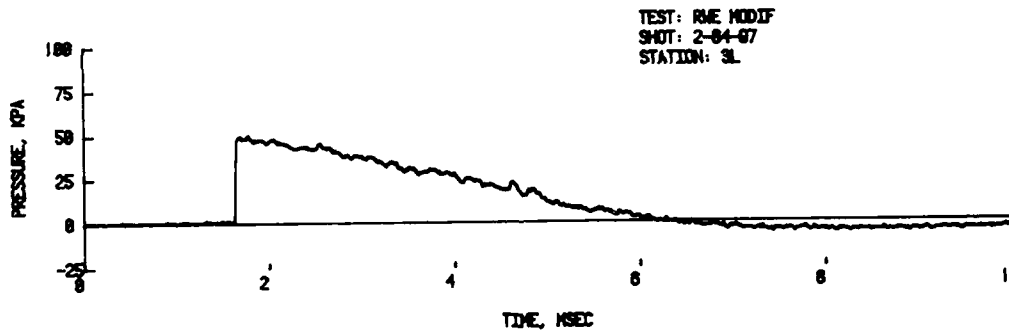
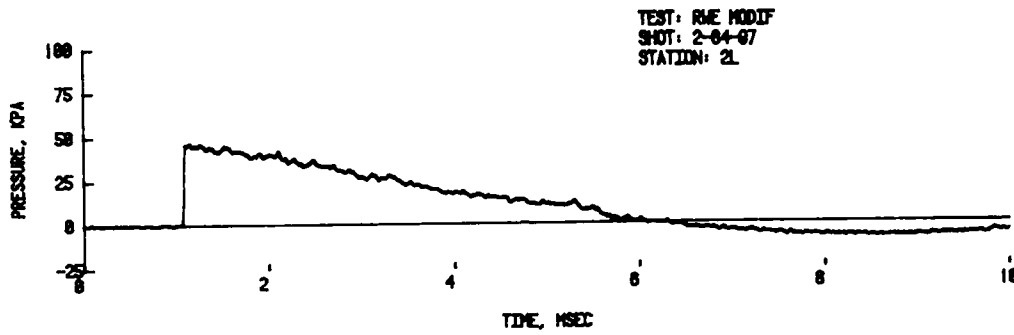
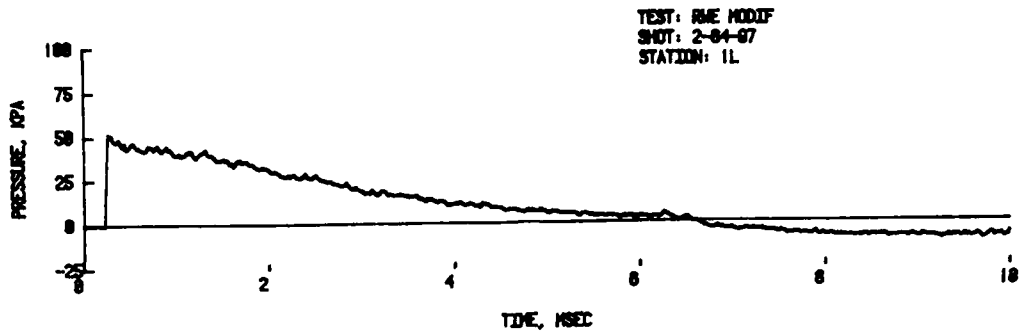

B. WITH RME

Figure 4. Overpressure Versus Time in a Long Shock Tube (cont.)

measured overpressures versus time are presented with no RWE attached to the tube. It can be seen that the effect of the RWE becomes greater for the stations nearest the open end (Station 4L). With the same test environment, the overpressures versus time were recorded at the same test stations, but with a RWE attached to the end of the shock tube. The results are shown in Figure 4B. It can be seen that the greatest change is at Station 4L.

The shape of the side-on overpressure changes when there is no RWE, but the change in dynamic pressure is even more dramatic. When the end of the shock tube is open to the atmosphere, the shock wave expands very rapidly, creating a rarefaction wave which moves up the shock tube causing a decay in the overpressure and an increase in dynamic pressure. This rapid decrease in the shock wave overpressure at Station 4L is shown in Figure 5A. Also shown in Figure 5A is the stagnation pressure and the resulting dynamic pressure. Note that the dynamic pressure is more than doubled at the arrival of the rarefaction wave at about 4 ms.

With the same shock wave input and a RWE attached to the end of the shock tube the resulting dynamic pressure is presented in Figure 5B. Here it can be seen that the dynamic pressure follows a classic decay. The large increase in dynamic pressure is eliminated by use of the RWE.

When considering the design requirements for a LB/TS, cost is a major factor. Therefore the shorter the expansion section the less the cost. With a short expansion section, the test section will of necessity be closer to the open end of the tube. For this study, four test stations were placed at selected distances from the open end of the shock tube as shown in Figure 2C. The rapid decrease in the shock wave overpressure recorded at the three test stations without a RWE is presented in Figure 6. Also shown in Figure 6 is the dynamic pressure recorded at Station 2 without the RWE.

#### B. Test Station Results with an Ideal RWE

In order to establish a baseline for comparing the effectiveness of the various RWE concepts, a series of tests was conducted in a long test section. The driver section remained the same, and the Stations 1, 2, 3, and 4 were the same distance down the tube from the diaphragm as shown in Figure 2B. But the tube was extended to a length where the rarefaction wave from the open end arrived late during the overpressure versus time decay curves. The overpressure versus time recorded at Stations 1 through 4 for the 50 kPa input pressure in the long tube are presented in Figure 7. Many of the comparisons will be made from the overpressure recorded at Station 2 and an input pressure of 50 kPa. Note that the third oscillation or peak on the overpressure versus time at Station 2 in Figure 7 is the time (1.2 ms) at which the rarefaction wave arrives at Station 2 in Figure 6. This is pointed out now because with some of the RWE's tested there appeared to be an excessive reflection at that point; but in fact, there is a small reflection already present in the input wave. Overpressure versus time at Station 2 in the long expansion section for 20, 50, 100, and 150 kPa with no RWE are presented in Figure 8.

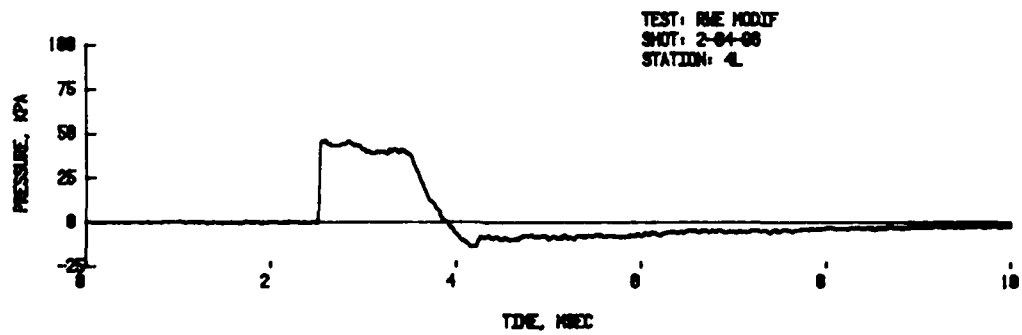
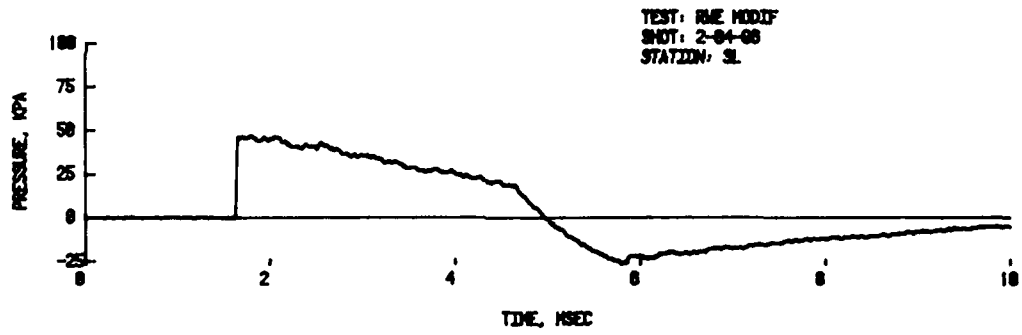
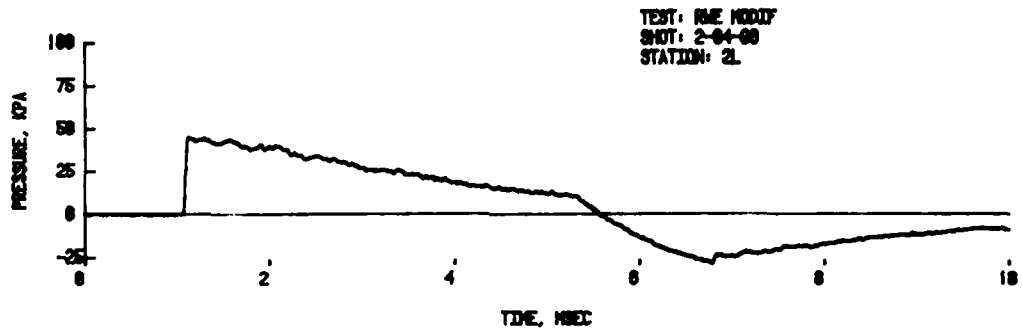
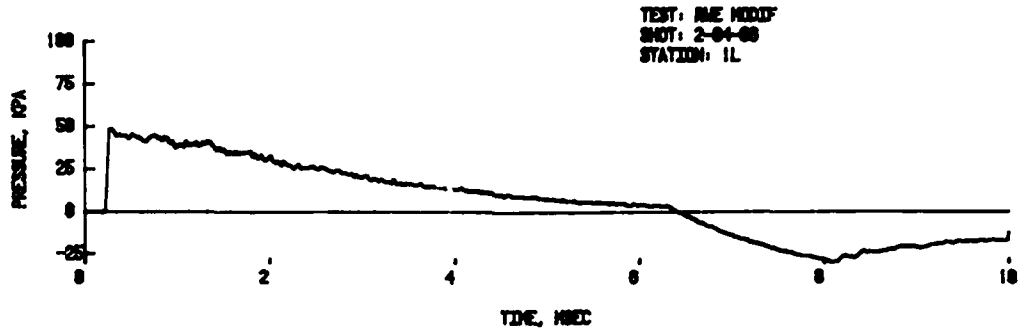

A. NO RME

Figure 4. Overpressure Versus Time in a Long Shock Tube

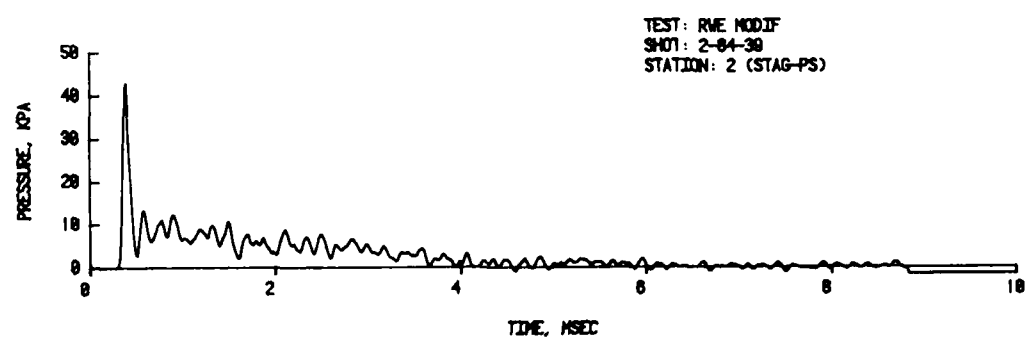
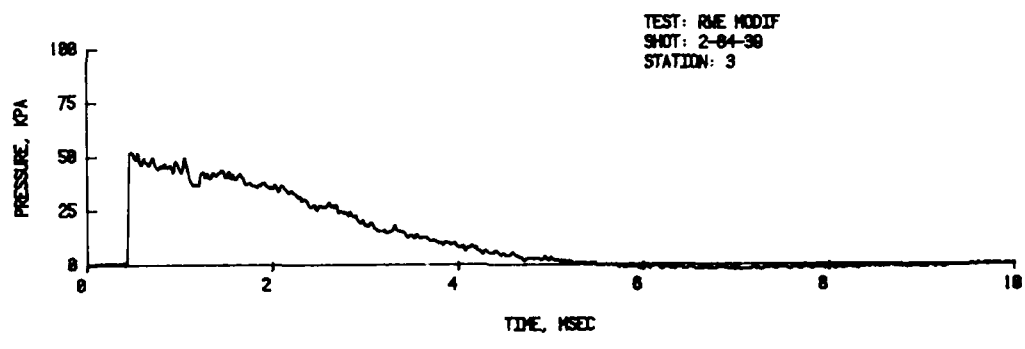
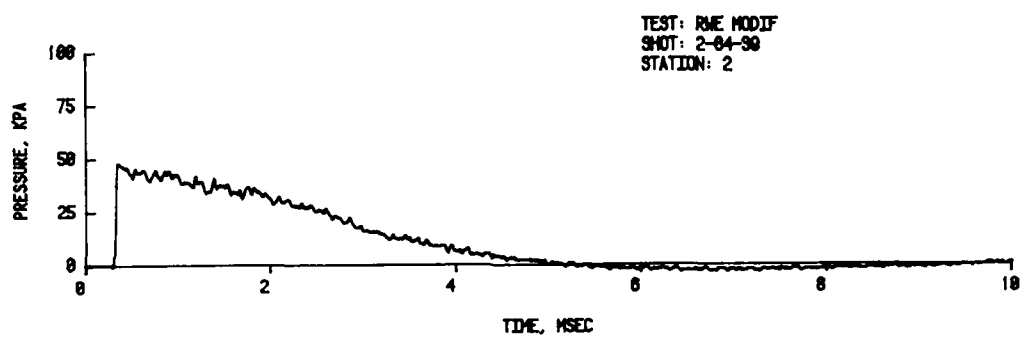
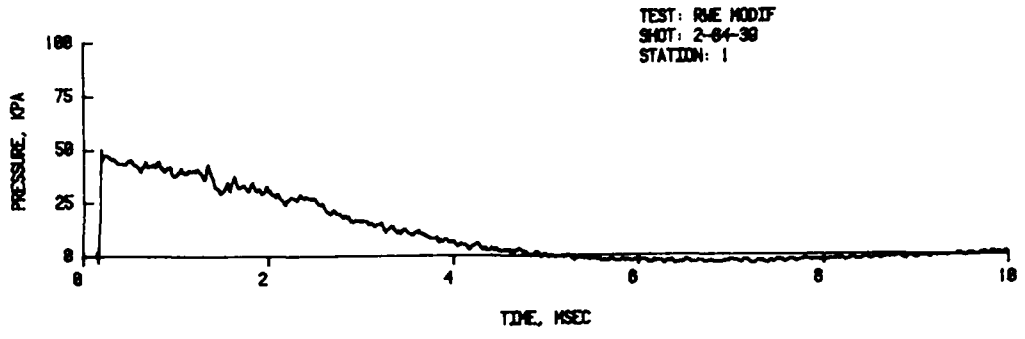

Figure 12. Foam Plate RWE, 50 kPa Input Pressure

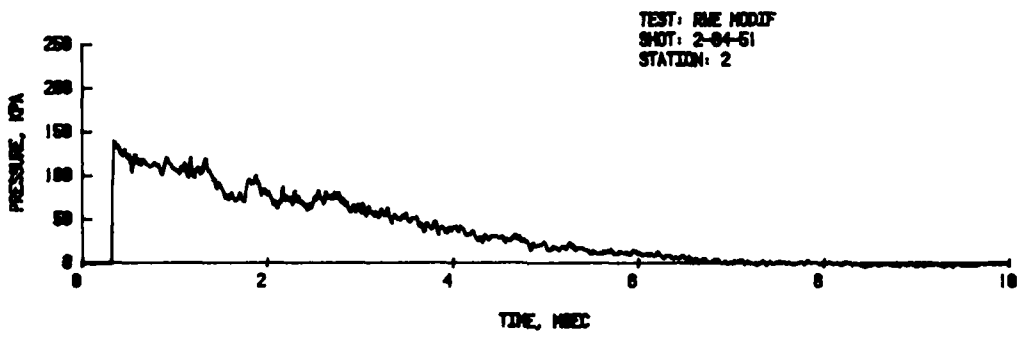
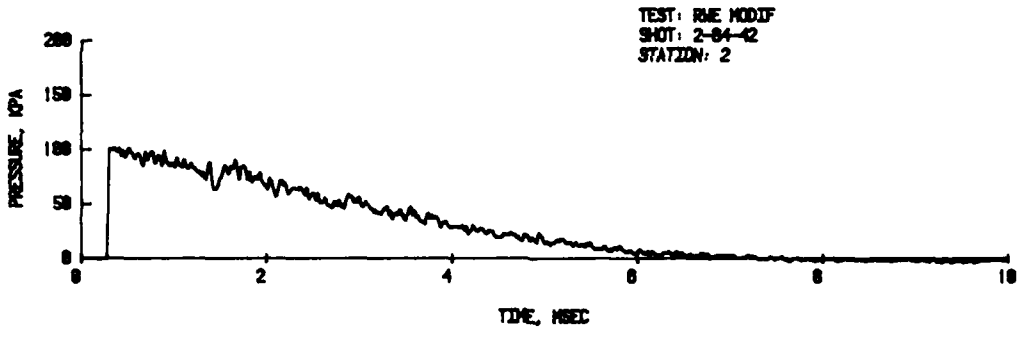
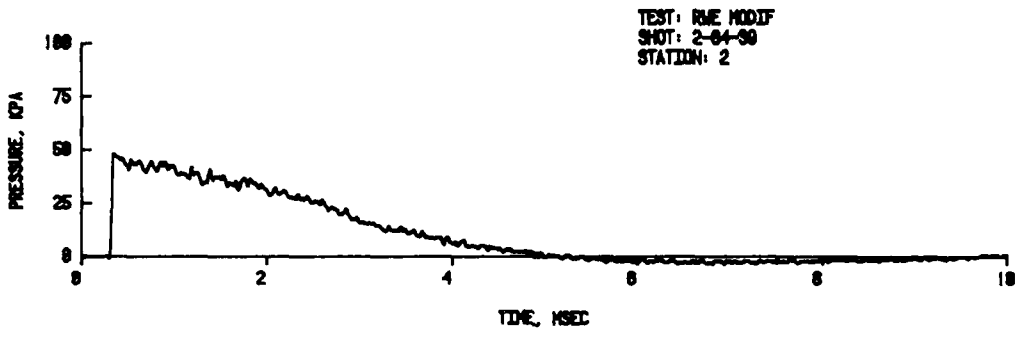
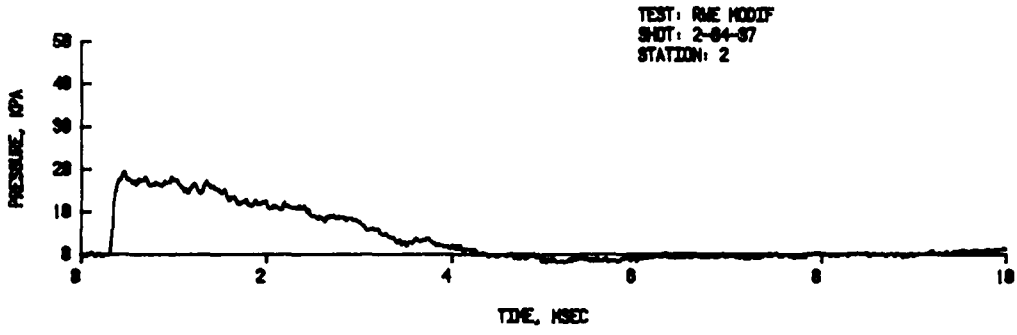

Figure 13. Foam Plate RWE, Station 2, Input Pressures 20, 50, 100, and 150 kPa

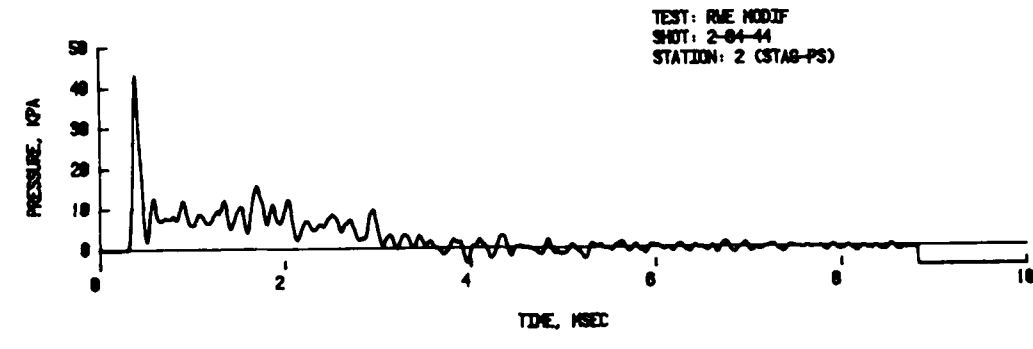
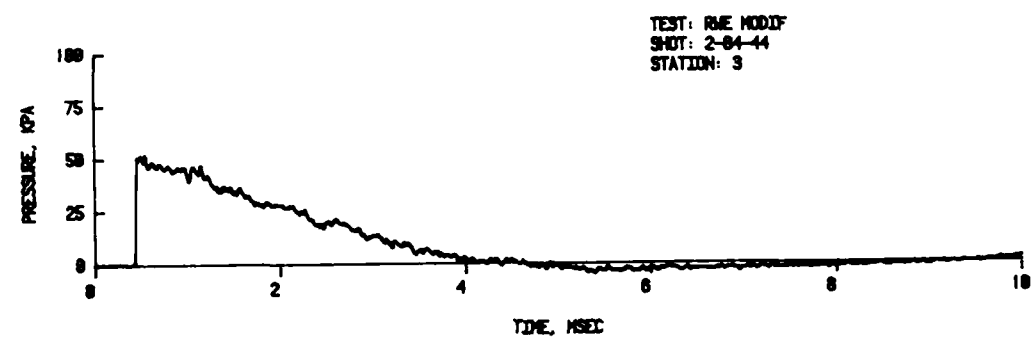
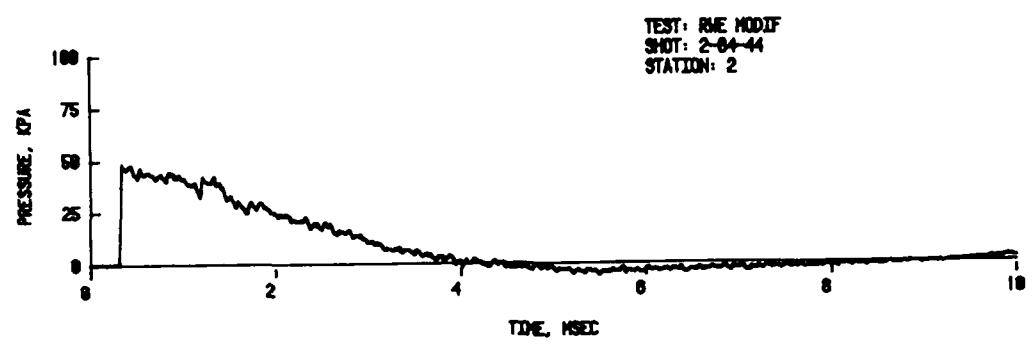
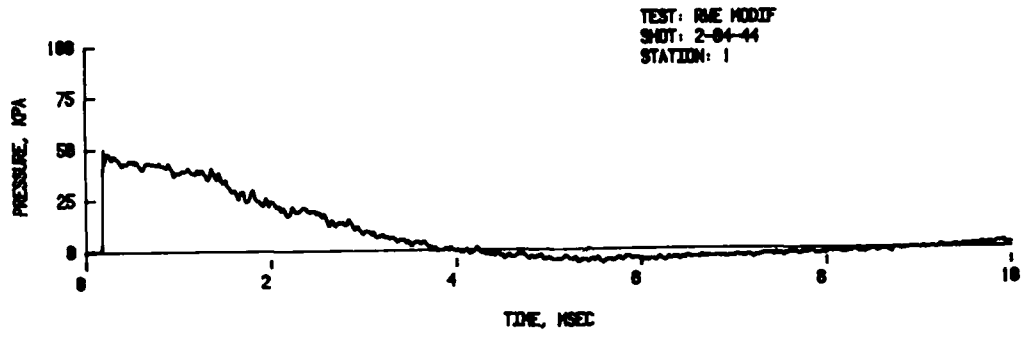

Figure 14. Vented Foam Plate 500, 50 kPa Input Pressure

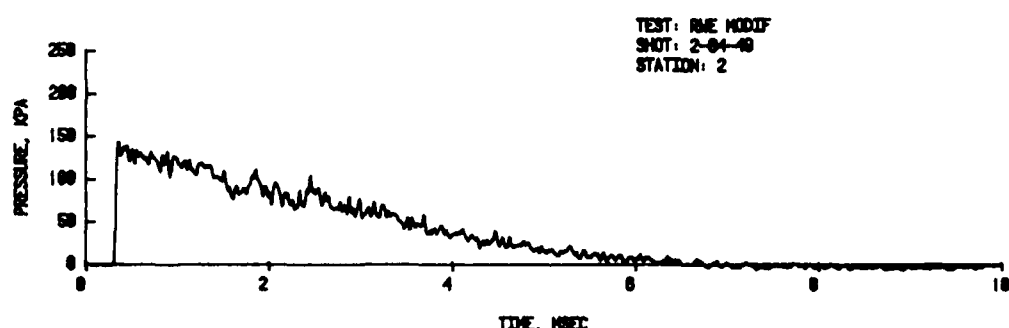
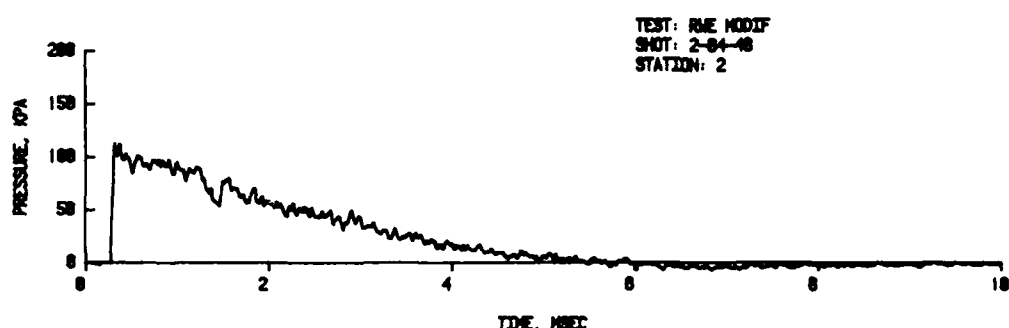
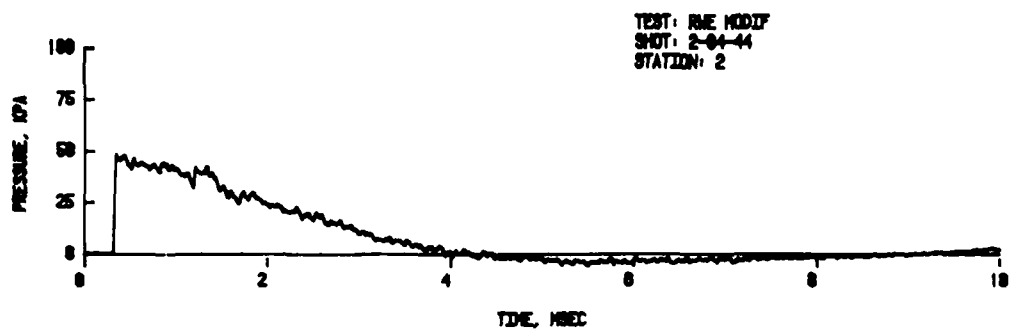
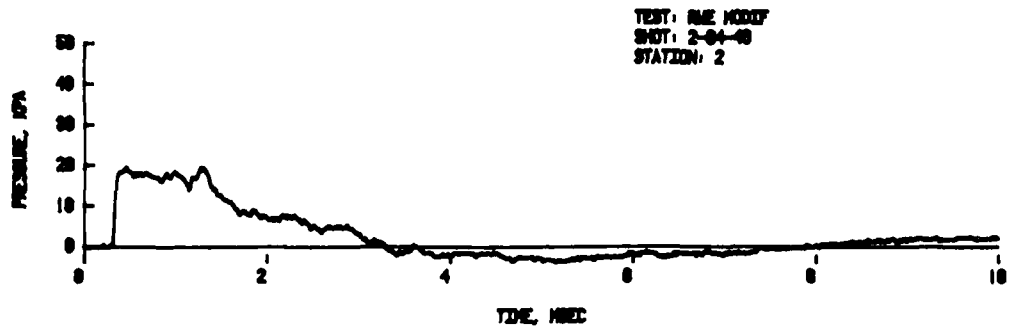

Figure 15. Vented Foam Plate RPP, Station 2, Input Pressure 20, 50, 100, and 150 kPa

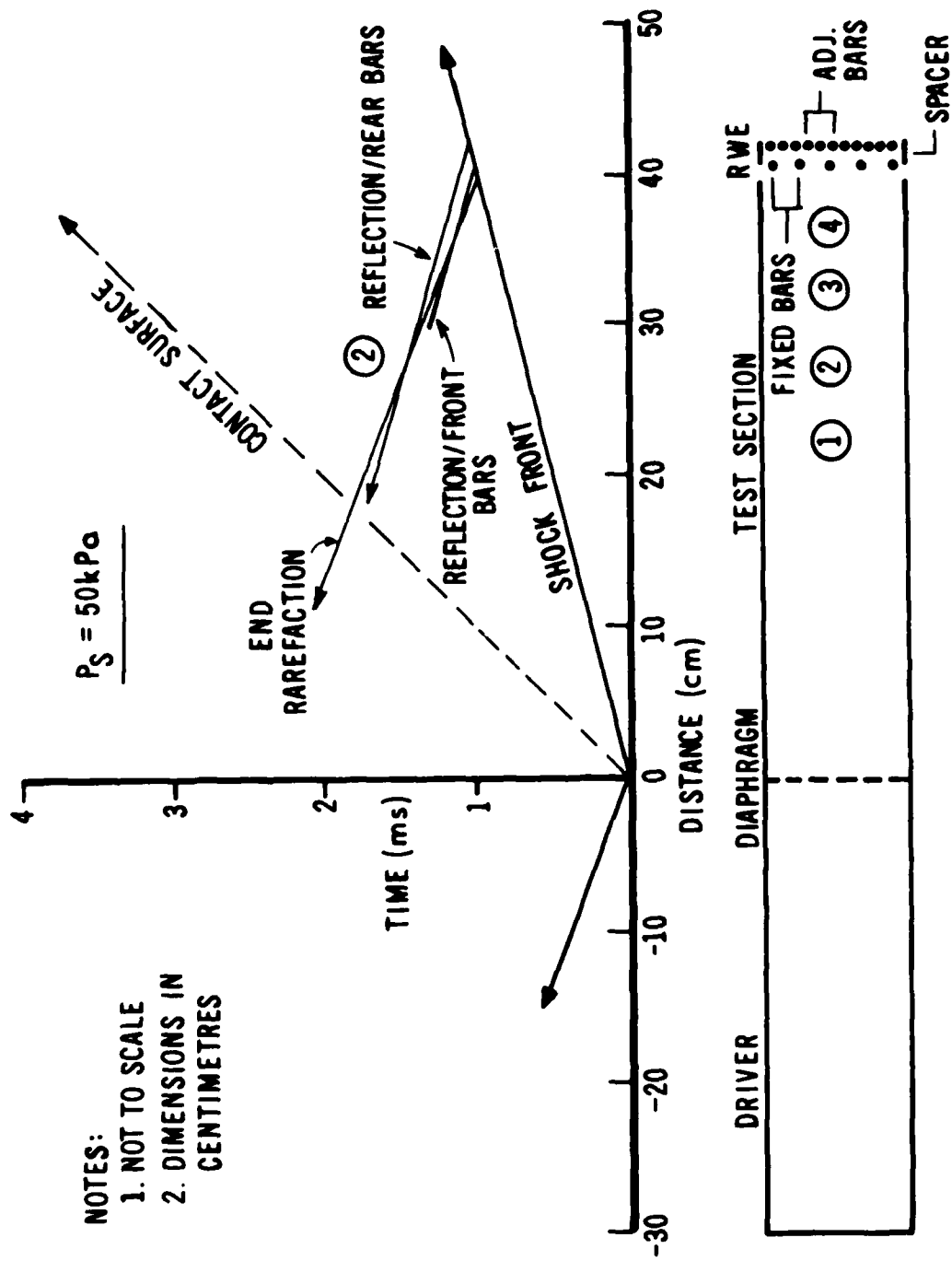

Figure 16. Wave Diagram for 5.08 cm Shock Tube

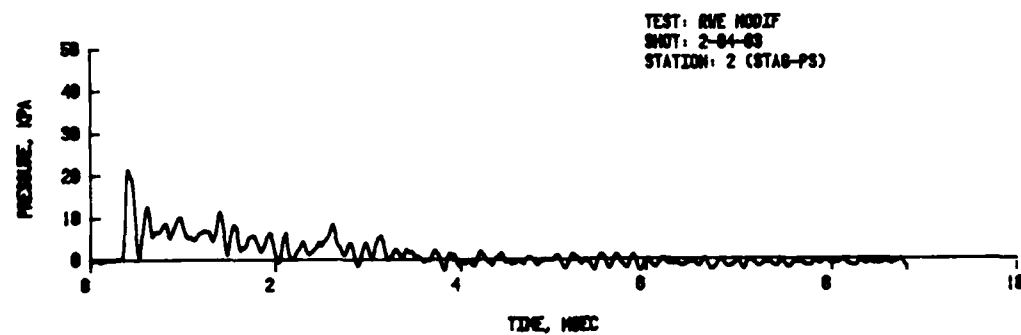
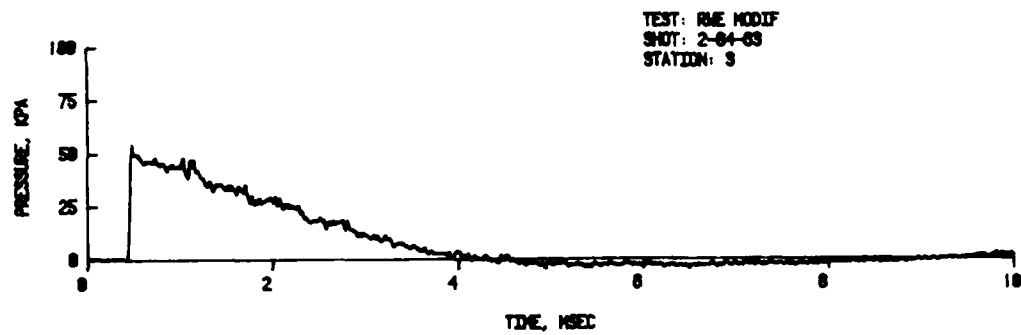
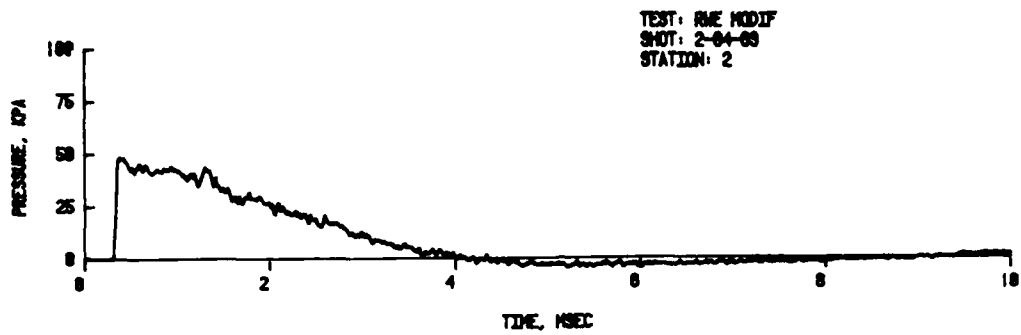
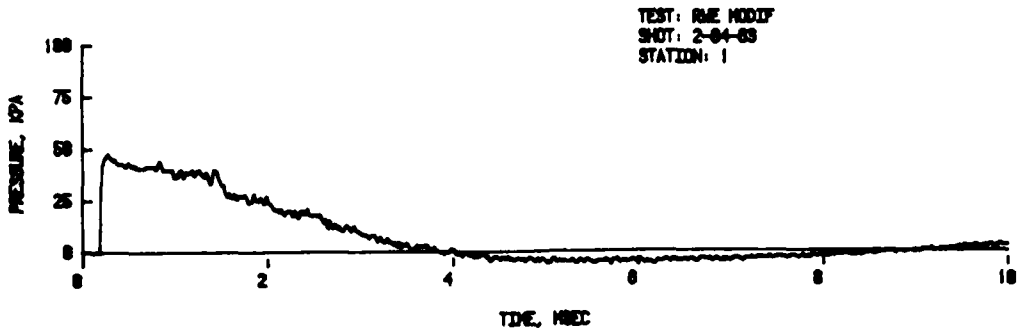

Figure 17. Multiple Bar FWE, 50 kPa Input Pressure

are presented for input pressures of 20, 50, 100, and 150 kPa. There is better overall consistency in the wave shapes and elimination of the rarefaction wave over the pressure range tested of 20 kPa through 150 kPa than was evident in the other RWE concepts.

#### G. Test Section Results with other Types of RWE's

Other methods of eliminating the rarefaction wave were tested. They are listed in Table 1, and the overpressures versus time for these concepts are presented in Figure 19 and discussed in the following paragraphs.

1. Needle RWE Concept. This concept utilized pointed needles facing upstream from a flat plate with holes drilled in it. The idea here is to start a reflection upstream from the needles and the mounting plate, and a rarefaction wave from the stand-off and the holes in the mounting plate. The first tests were with 83 plastic needles 1.2 cm in length moulded to a mounting plate. These needles fitted an area equal to the shock tube area. The overpressure versus time is presented in Figure 19A. The needles appeared to have little effect on the record which is very similar to the solid plate RWE results presented in Figure 11B. A second needle concept was tested where there were 126 metal needles. They were 1.5 cm in length and there were enough holes (119) drilled in the mounting plate to produce a vent area of  $3.738 \text{ cm}^2$ . A pressure-time record is shown in Figure 19B. The major reflection appears to come from the needle mounting plate, even when holes were drilled to reduce the reflection and increase the rarefaction. This concept was discarded because of the difficulty in controlling the variables and in designing a large scale RWE for the US LB/TS.

2. Bars-Single Row. During the program, a single row of bars was tested as a feasible RWE concept. The results gave overpressure versus time records similar to the flat plate RWE, although the reflected spike from the RWE was not as great as for the flat plate. A sample of the record at Station 2 is presented in Figure 19C.

3. Hollow Pipes RWE. The hollow pipes RWE concept consisted of nineteen thin wall pipes, 2.54 cm in length. The upstream end of the pipes was beveled with a 45 degree angle in order to decrease the reflecting surface. This type of RWE also sent a strong reflected wave upstream and was followed by a strong rarefaction wave. The overpressure-time record obtained from the pipes RWE is presented in Figure 19D.

4. Steel Wool RWE. Steel wool was considered for an RWE because, like the foam materials, it has a shock absorption property also. Some compression of the steel wool occurred causing a slight rarefaction before the reflected peak arrived at the test station. The resulting pressure-time record again resembled that from the flat plate RWE. An example from Station 2 is shown in Figure 19E.

5. Sharp Edge Slats RWE. An RWE was constructed of eleven plastic knives 16 mm wide. The edges had initial slopes of 45 degrees (first 1.5 mm) followed by a 10.6 degree slope, ending at a thickness of 3 mm. The sharp edges were expected to create a number of small reflections upstream instead of a single objectionable large one at the test station. However, a large peak

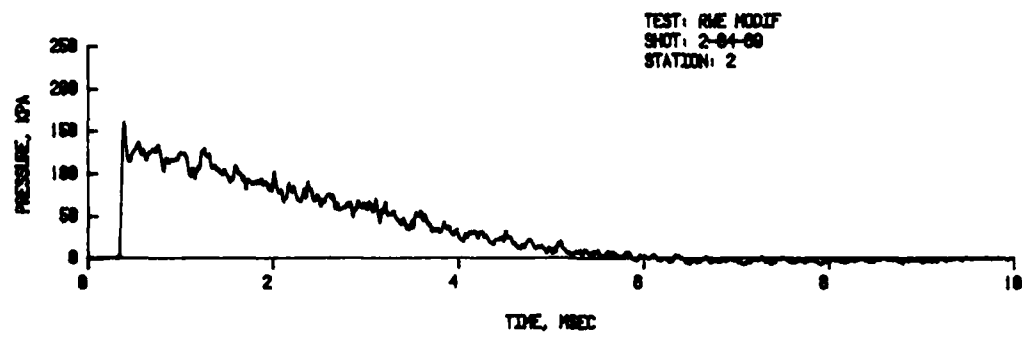
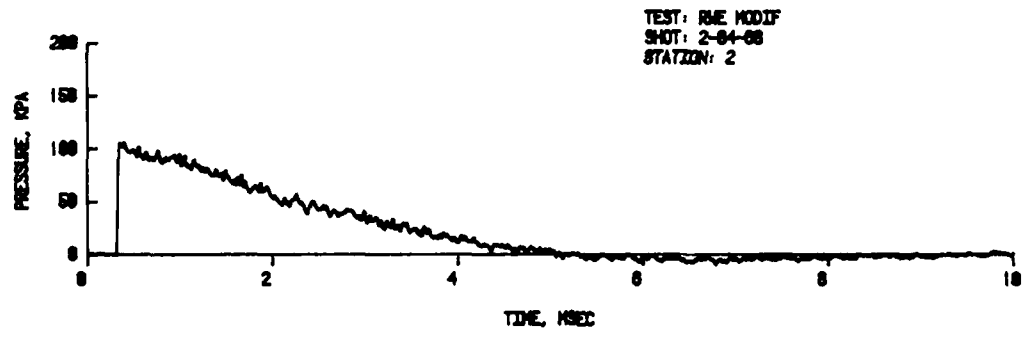
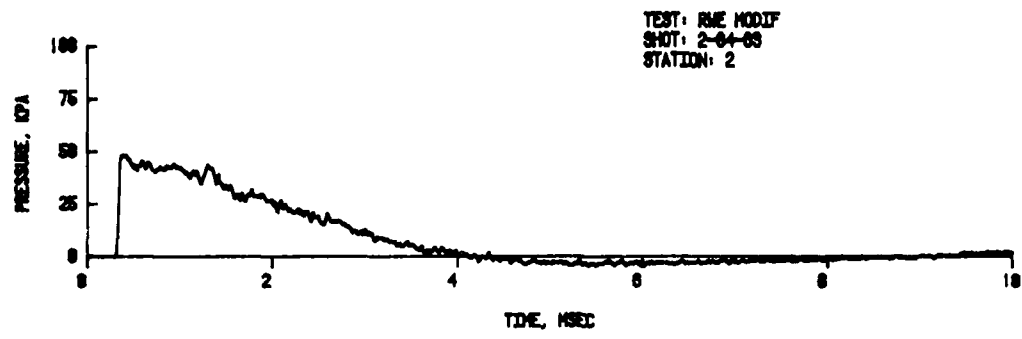
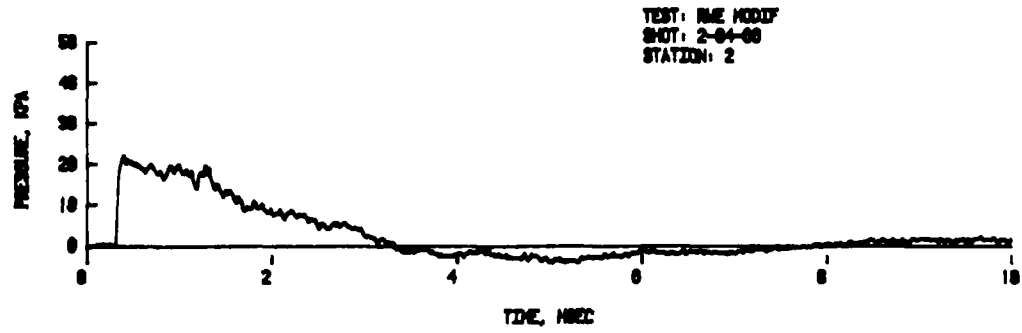
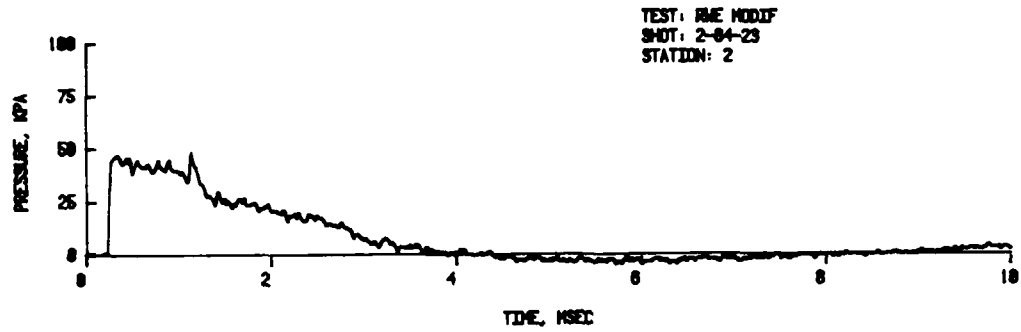
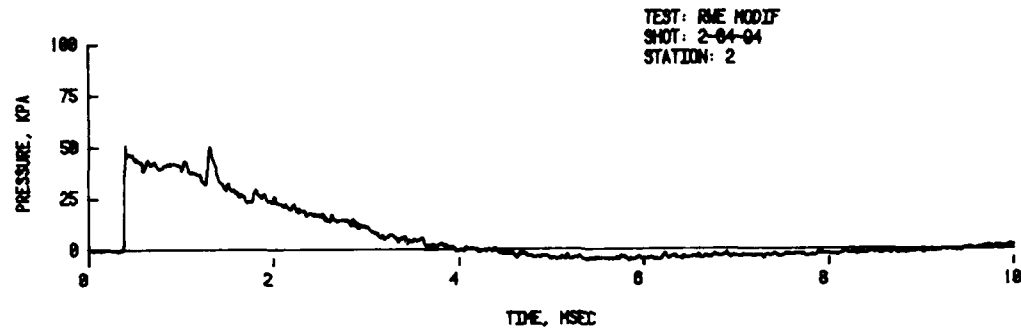

Figure 18. Multiple Bar RME, Station 2, Input Pressures  
20, 50, 100, and 150 kPa



A. Plastic Needles/Holes in Plate



B. Metal Needles/Holes in Plate

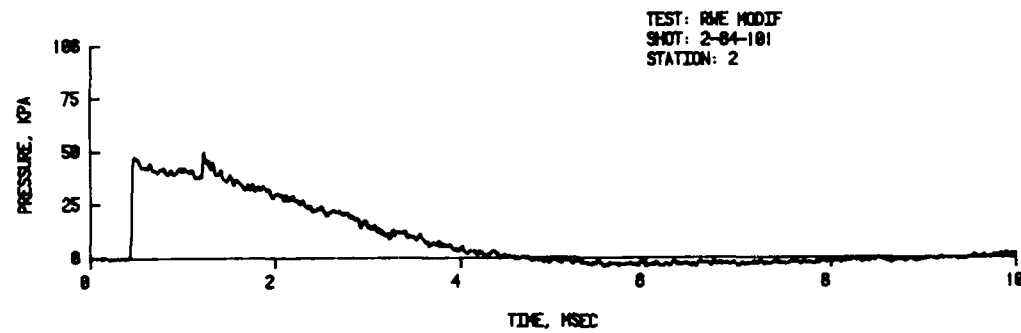

C. Bars, Single Row

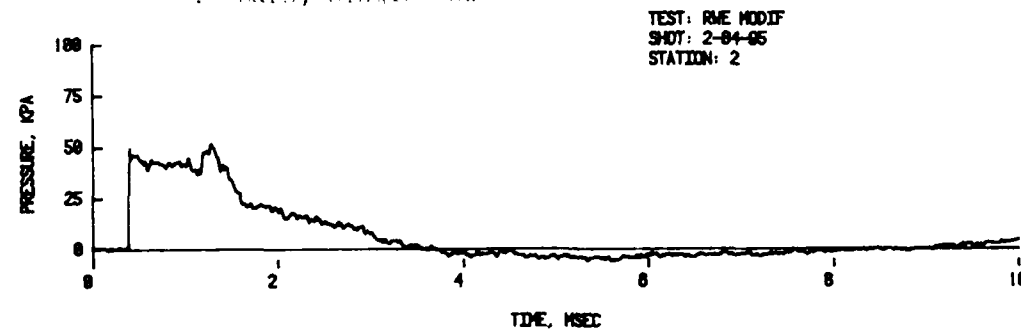

D. Pipes

Figure 19. Other RME Concepts, 50 KPa Input Pressure

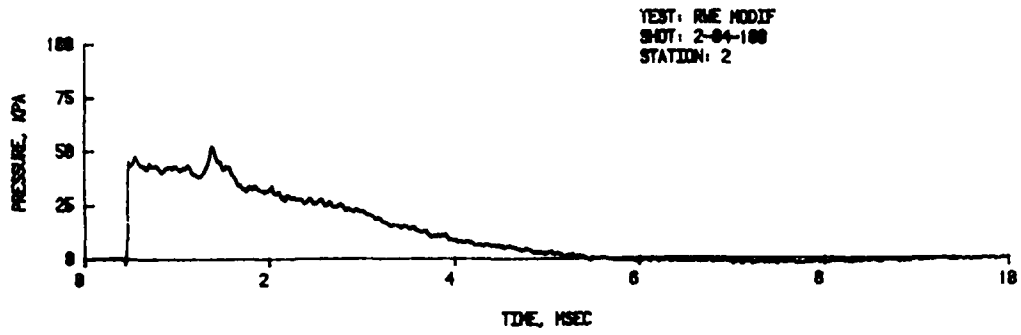

E. Steel Wool

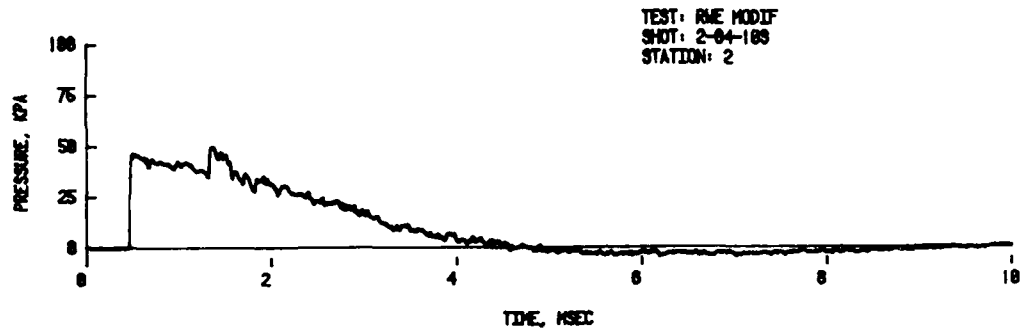

F. Sharp Edge Slats

Figure 10. Other FRP Concepts, 50 kPa Input Pressure (cont.)

reflection was still formed as shown in Figure 19F. Again, the RWE was not acceptable and was perhaps a little less effective than the steel wool.

#### IV. RESULTS OF LARGER SCALE TESTS

Results are presented in this section for experiments with RWE's on two larger BRL shock tubes: (1) the 0.57 metre tube, and (2) the 2.44 metre tube.

##### A. Test Section Results from 0.57 Metre Shock Tube

Two of the most efficient concepts for RWE's, the vented foam and the multiple bars, were scaled up 11.2:1 to the BRL 0.57 metre shock tube<sup>8</sup> from the small scale model 5.08 cm shock tube. A sketch of the 0.57 metre shock tube is shown in Figure 20. Transducer Stations 1, 2, and 3 were near the open end of the shock tube. Station 4 was located 20.088 m from the end so as to give an undisturbed pressure-time input record. This then would be the ideal waveform to be matched from the RWE.

The two RWE's are shown in the photographs of Figure 21; the upper is of the vented foam and the lower is of the multiple bars. The foam consisted of a 4.9 cm thick layer of soft, fine grain polyether (HyFonic 1, Scott Paper Co.) and a second layer of soft polyurethane mattress foam glued with rubber cement. The mattress foam was studded with four-sided blunt cones, 5 x 5 cm base x 7.5 cm high with rounded 1.3 cm diameter top. A circular pipe spacer and a stand-off at the end of the shock tube completed the arrangement of the vented foam RWE.

Figures 22-25 compare the pressure-time records obtained without the RWE with those when the vented foam RWE was used.

The spacer was designed so as to best match Station 1. This is seen in Figure 25. The reflected peak is effectively reduced but is preceded by a rarefaction created in part by the foam's over-compression.

The second RWE tested on the 0.57 metre shock tube consisted of a stand-off, fixed set of five bars (2.54 cm O.D. pipes), a cylindrical spacer, and a final set of adjustable (removeable) bars. The vented area could be varied by both the stand-off distance and by the number of bars left in place.

The results are shown in Figure 26. The positive wave duration obtained with the RWE is somewhat less than for the ideal input wave (Station 4) but is quite acceptable.

Results for both types of RWE's scaled quite well for the scale change of 11.2:1.

---

<sup>8</sup> George A. Coulter and Brian P. Bertrand, "BRL Shock Tube Facility for the Simulation of Air Blast Effects," Ballistic Research Laboratory Memorandum Report No. MR-1685, August 1965 (AD #475669).

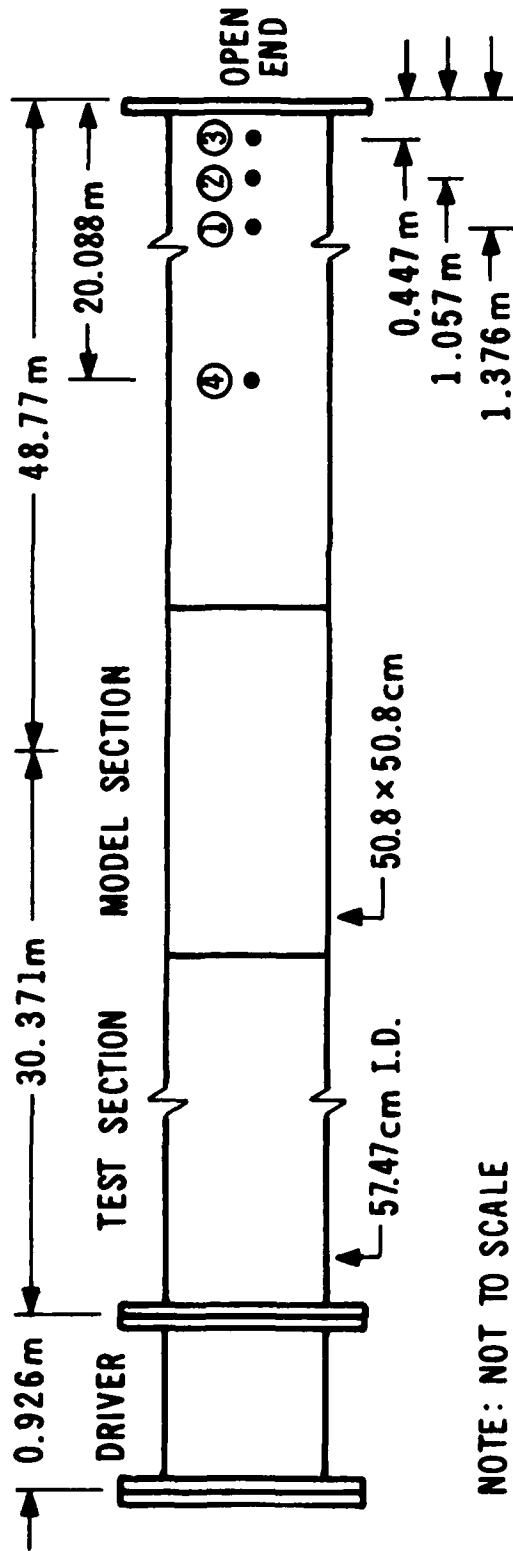

Figure 20. Sketch of BRL 0.57 Metre Shock Tube



A. Vented Foam RWE



B. Multiple Bars RWE

Figure 21. RWE's for BRL 0.57 Metre Shock Tube

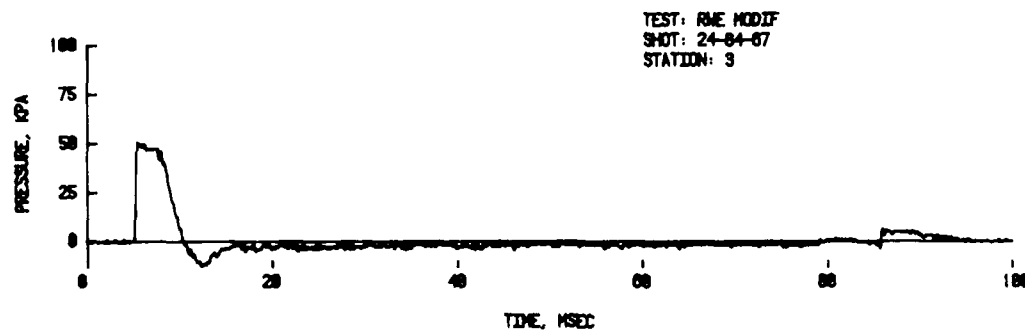
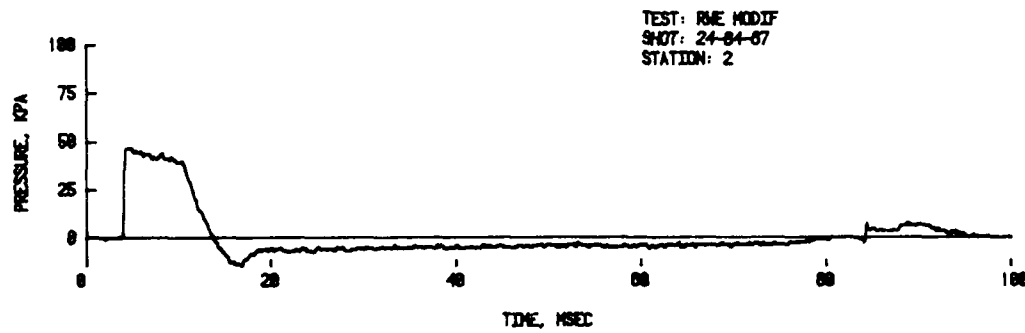
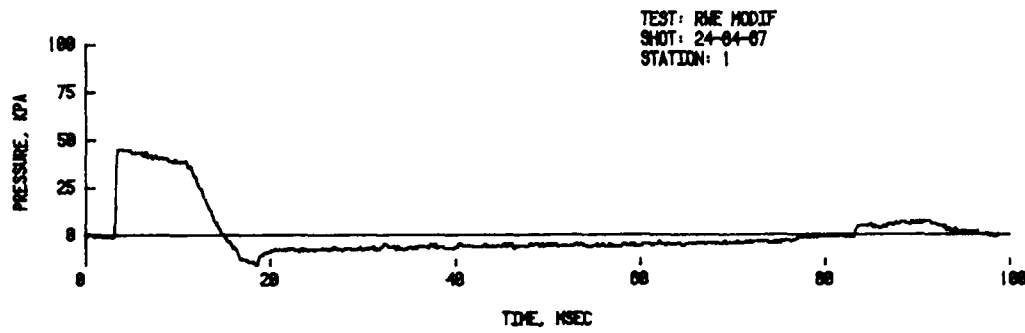
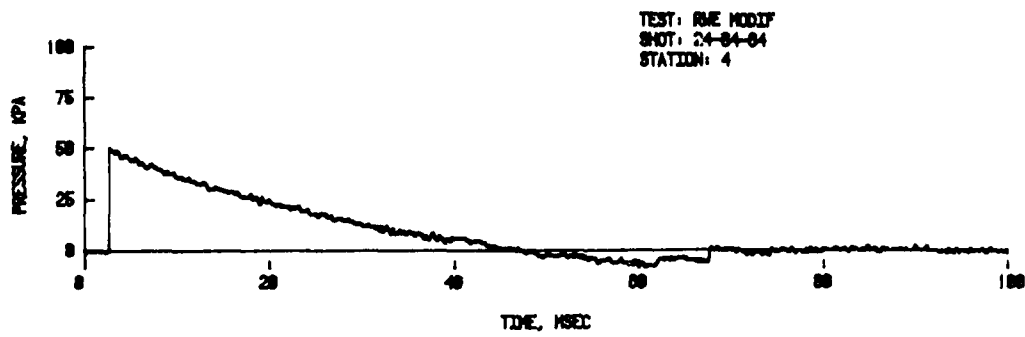

Figure 22. Pressure-Time Records, No RME, 50 KPa Input Pressure, 1.57 Metre Shock Tube

## LIST OF REFERENCES

1. George A. Coulter, Gerald Bulmash, and Charles N. Kingery, "Experimental and Computational Modeling of Rarefaction Wave Eliminator Suitable for the BRL 2.44 m Shock Tube," Ballistic Research Laboratory Technical Report No. ARBRL-TR-02503, June 1983 (AD #A131894).
2. A. Cadet and J.B.G. Monzac, "Le Simulateur De Souffle a Grand Gabarit Du Centre D'Etudes De Gramat: Description et Utilisation Operationnelle," Seventh MABS Symposium, DRES, Canada, July 1981.
3. George A. Coulter, Gerald Bulmash, and Charles Kingery, "Feasibility Study of Shock Wave Modification in the BRL 2.44 m Blast Simulator," Ballistic Research Laboratory Memorandum Report No. ARBRL-MR-03339, March 1984 (AD #A139631).
4. Lippe D. Sadwin and Jerald Berman, "Reflection and Rarefaction Elimination in Conical Shock Tubes," Military Applications of Blast Simulators Symposium, DRES, Canada, July 1967.
5. W. Haverdings, "Evaluation of a Reflection Eliminator for a 40 x 40 cm<sup>2</sup> Blast Simulator," Prius Maurits Laboratorium, The Netherlands, INTRIM Report 53178, July 1981.
6. J.F. Procter, "Airblast Effects Simulation and Response, Part II of A Facility for Simulation of Thermal Radiation-Airblast Effects," Third MABS Symposium, Ernst Mach Institute, Freiburg, Germany, September 1972.
7. I.C. Leys, "Model Scale Experiments for the Development of An Extension to the AWRE Foulness Nuclear Blast Simulator," Seventh MABS Symposium, DRES, Canada, July 1981.
8. George A. Coulter and Brian P. Bertrand, "BRL Shock Tube Facility for the Simulation of Air Blast Effects," Ballistic Research Laboratory Memorandum Report No. MR-1685, August 1965 (AD #475669).

desired input pressure level. The side vents near the end of the shock tube could replace the stand-off requirement for the multiple bar RWE concept.

In conclusion, if the cost analysis (not a part of this research) finds a static (or passive) RWE to be cost-effective to fabricate and operate, as opposed to an active RWE, then a multiple bar RWE concept is recommended for the proposed Large Blast/Thermal Simulator.

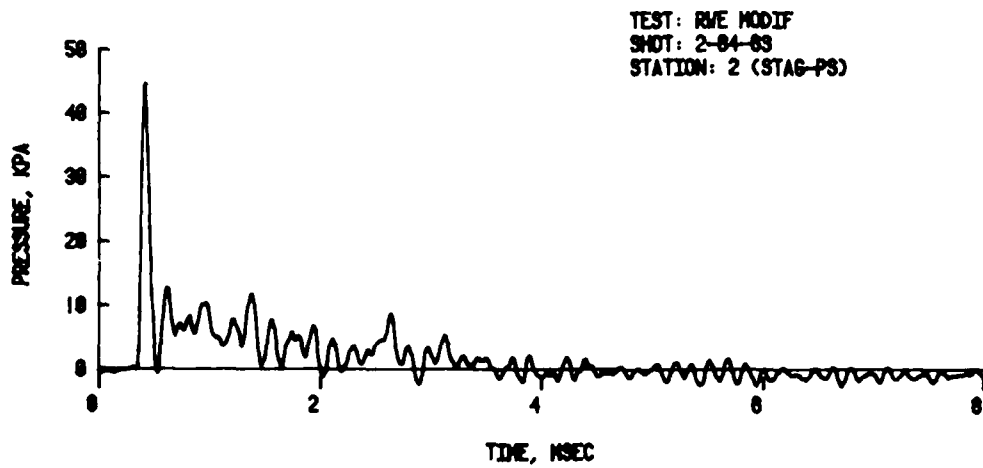
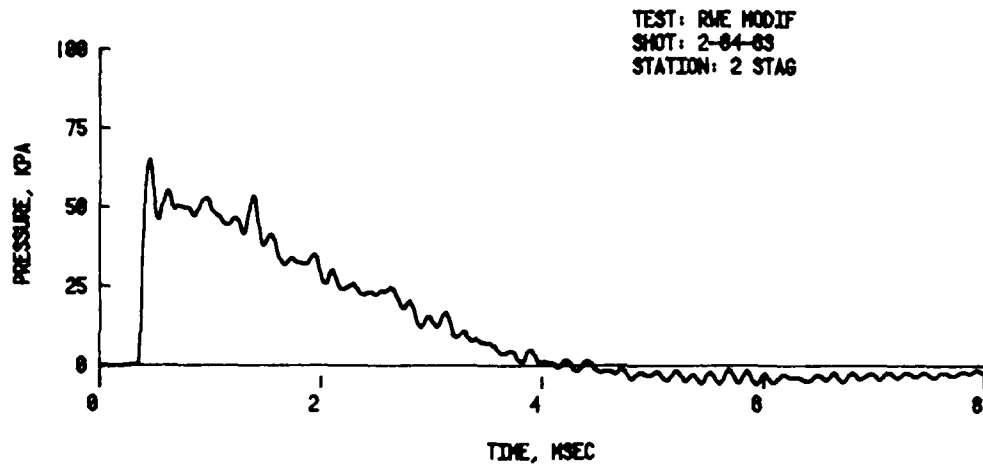
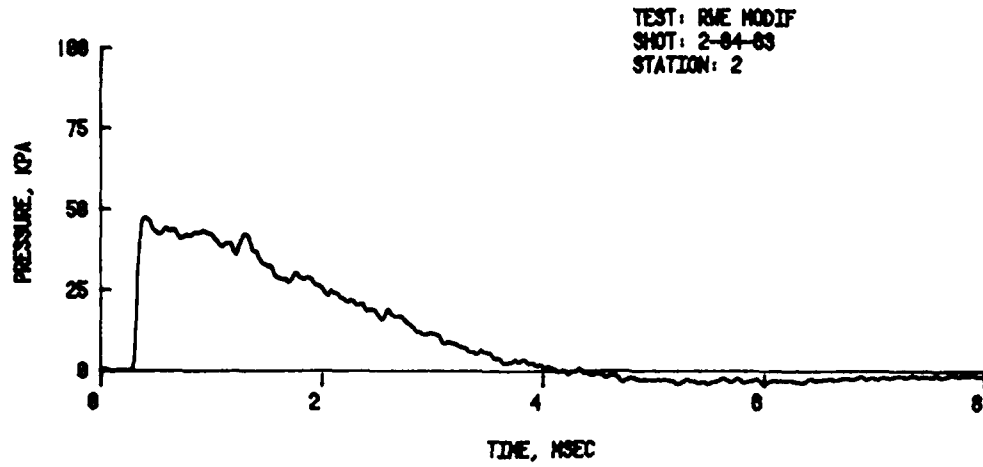

1. BARS

Figure 29. Dynamic Pressure Versus Time Comparisons: (cont.)

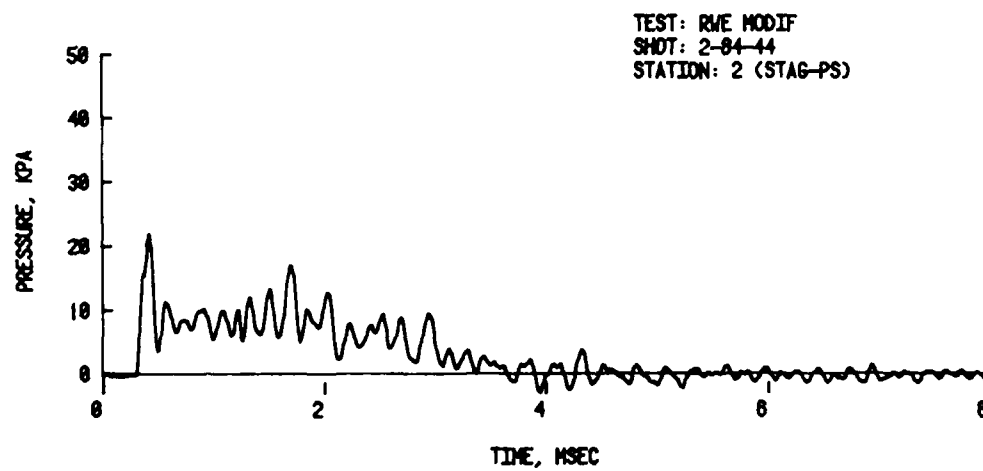
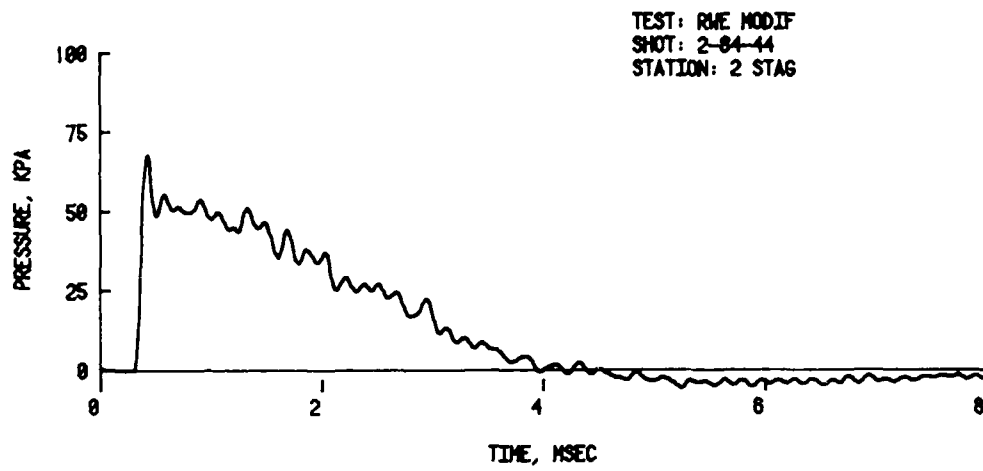
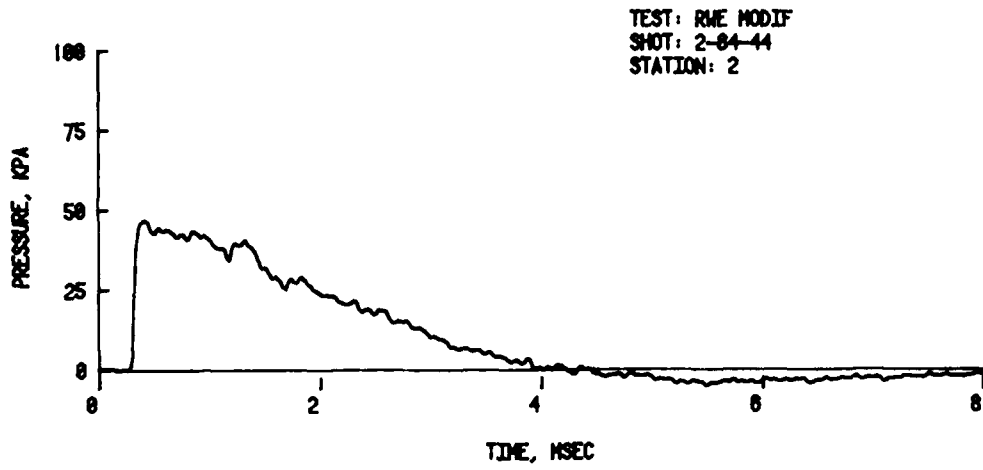

(C) VENTED PLATE/FOAM

Figure 29. Dynamic Pressure Versus Time Comparisons (cont.)

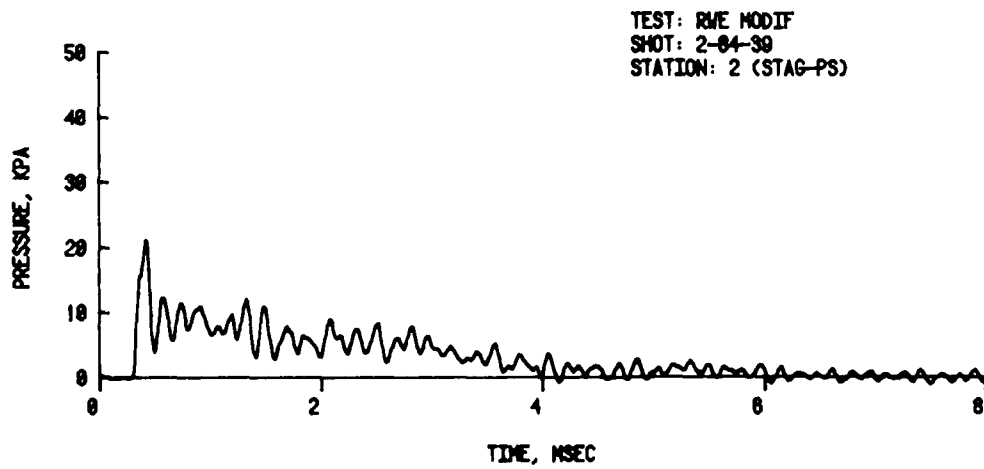
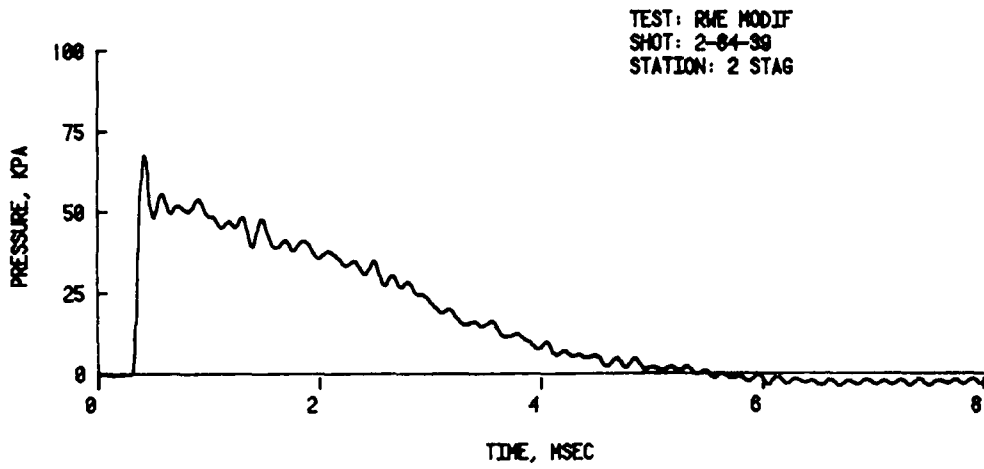
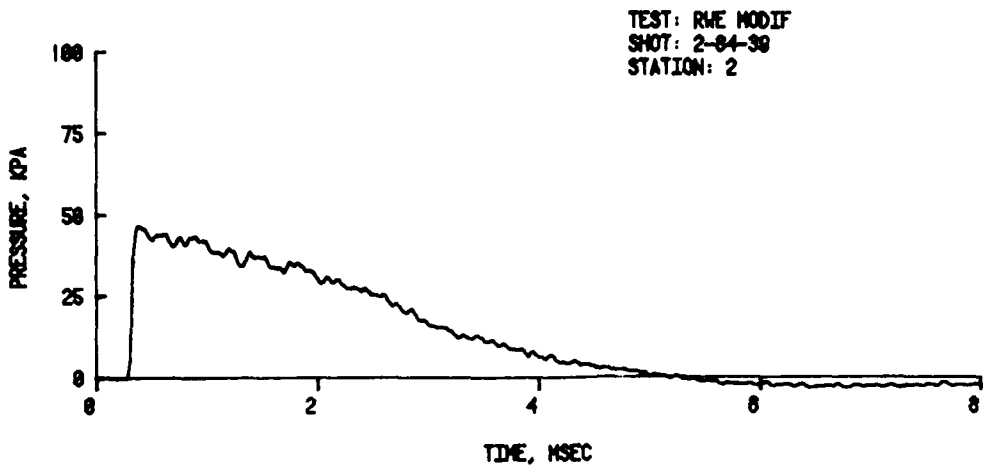

B. SOLID PLATE/FOAM

Figure 29. Dynamic Pressure Versus Time Comparisons (cont.)

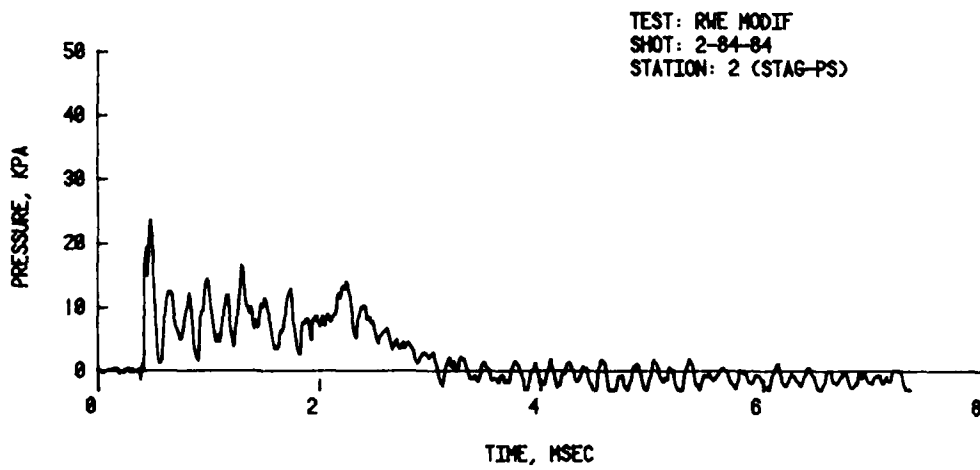
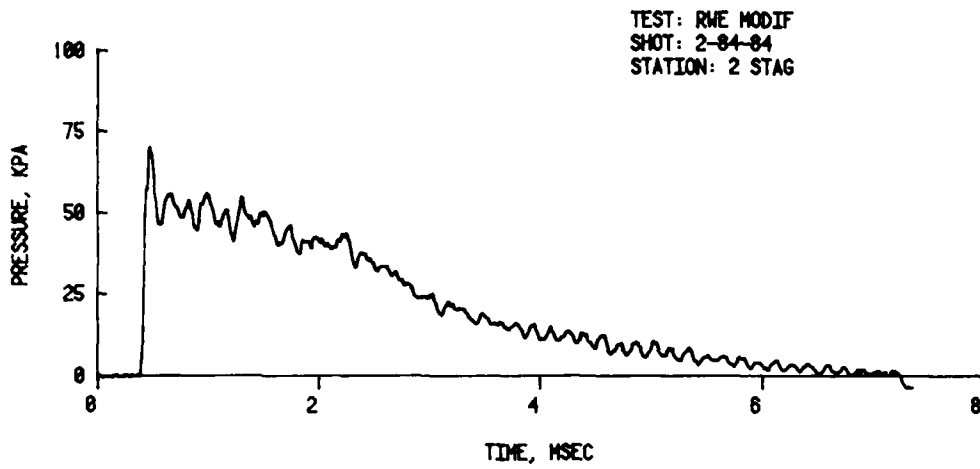
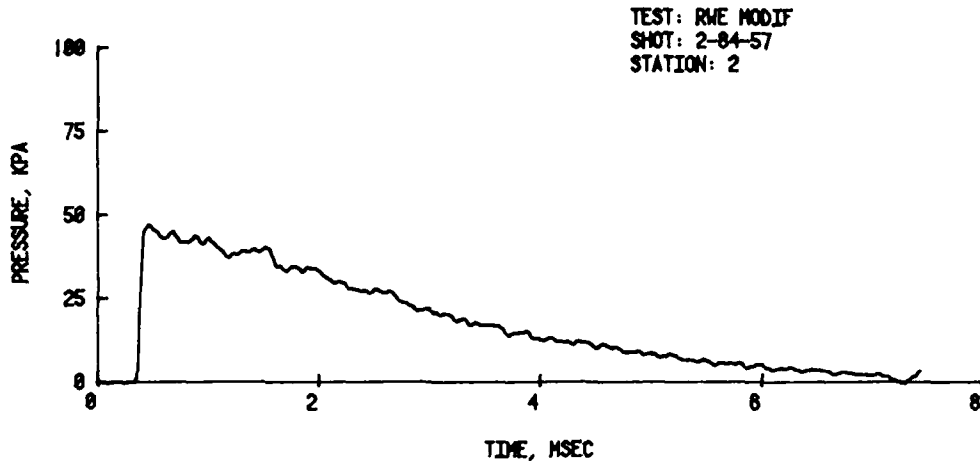

A. LONG TEST SECTION

Figure 29. Dynamic Pressure Versus Time Comparison

comparisons because the dynamic pressure predicted for 50 kPa (7.2 psi) is approximately 8.3 kPa (1.2 psi).

The (STAG-PS) for the Solid Plate/Foam RWE is presented in Figure 29 B. Here it can be seen that both the STAG and PS versus time have shorter durations than obtained from the long expansion tube, while the dynamic pressure is similar in magnitude but with a longer duration.

The pressure versus time recorded at Station 2 using the Vented Plate/Foam RWE are presented in Figure 29C. The STAG and PS are similar to the records presented in Figure 29B. Likewise the dynamic pressure is also similar to that presented in Figure 29B.

The Multiple Bar RWE results recorded at Station 2 are presented in Figure 29D. The stagnation and side-on pressure versus time are almost identical to the Vented Plate/Foam RWE results presented in Figure 29C.

It should be noted the primary difference between the stagnation and side-on pressure recorded in the Long Test Section (Figure 29A) and these recorded with the three RWE concepts is the shorter positive duration of the shock wave when RWE's were used.

#### CONCLUSIONS AND RECOMMENDATIONS

A series of experiments was carried out at the BRL Shock Tube Facility to determine effective rarefaction wave eliminator (RWE) concepts that would be applicable to the proposed U.S. Large Blast/Thermal Simulator (LB/TS). A 1/285th scale shock tube model was designed and built to test several RWE concepts. A number of concepts were tested: flat plate, flat plate/foam, vented plate, vented plate/foam, single set of bars, multiple sets of bars, needles, pipes, sharp edged slats, and steel wool. Of these, the two most promising were found to be the vented/foam and multiple bars RWE's.

These two types of RWE's were scaled up about eleven times for testing on the BRL 0.57 metre shock tube. At the pressure levels tested, 50 and 100 kPa, the pressure-time records compared well with those obtained with smaller scale 5.08 cm shock tube. The plain vented RWE (no foam) was also scaled up to the BRL 2.44 metre shock tube. Again, the results were satisfactory. It is felt that either concept, therefore, could be scaled to the LB/TS.

Of the two concepts, a large vented/foam RWE would be more difficult to design and fabricate than a multiple bar RWE. The multiple bar RWE also has the advantage of being more adjustable with removeable bars to change the vented area in addition to stand-off distance venting. The spacer length would allow for fine adjustment to a particular test station. A station choice of between 2.5 to 3 test section diameters from the tube's open end is recommended.

A second refinement in the design of the RWE for the LB/TS might be to replace the stand-off distance venting with adjustable vent openings in the shock tube wall. The RWE would need only adjustment of the main bars to give the correct ratio of vented RWE area to test section area (Figure 28) for the

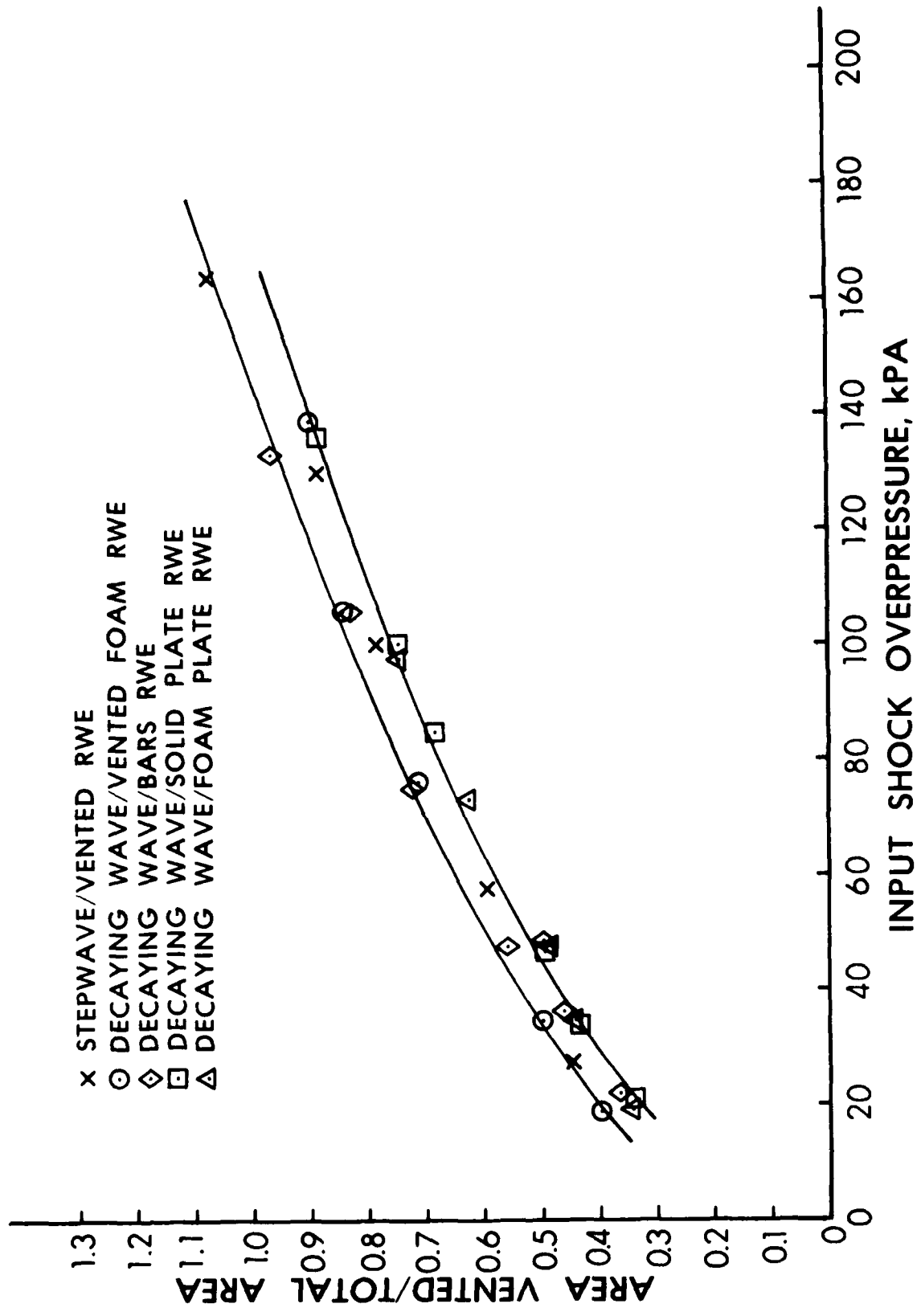
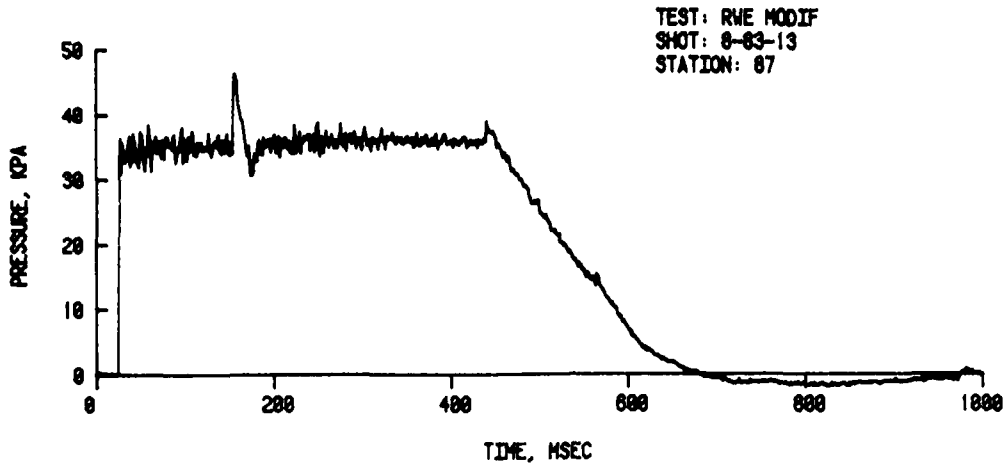
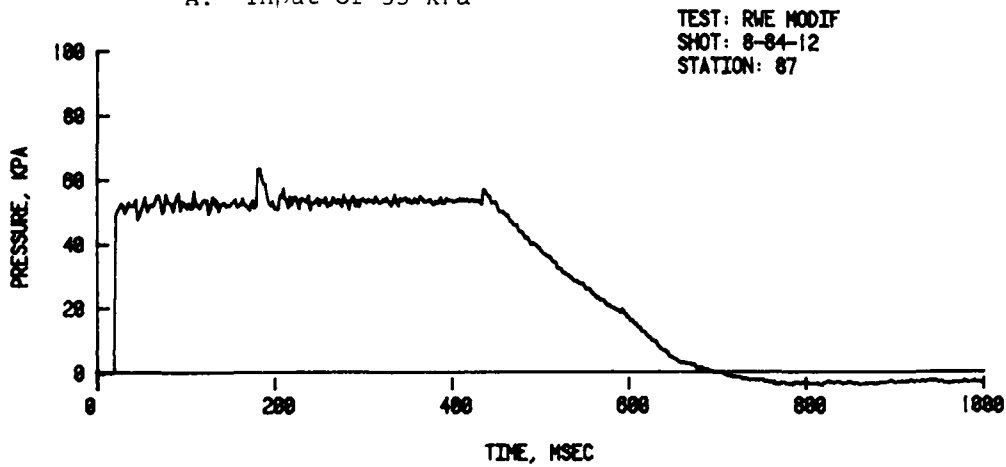

Figure 28. Vent Area Ratio Versus Test Station Overpressure



A. Input of 35 kPa



B. Input of 50 kPa

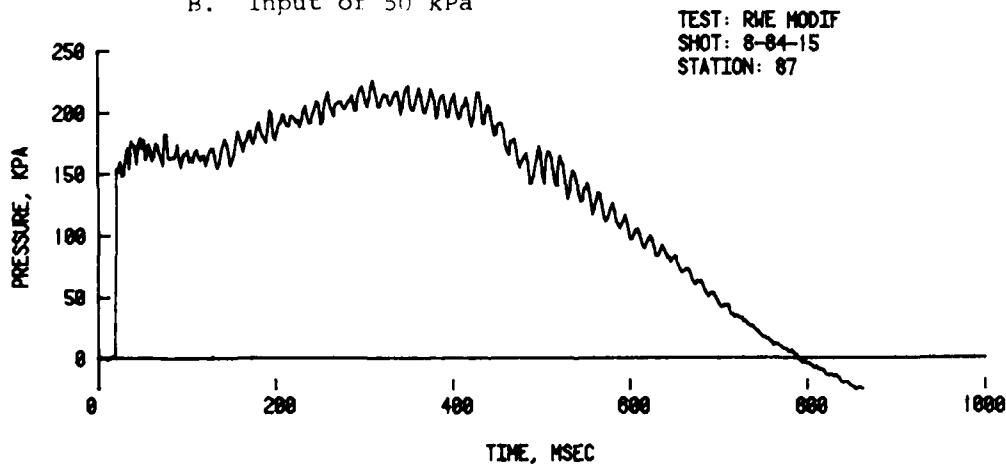

C. Input of 145 kPa

Figure 27. Pressure-Time Records, Vented RWE, Input Pressures 35, 50, and 145 kPa, BRL 2.44 Metre Shock Tube

## B. Test Section Results from 2.44 Metre Shock Tube

Results will be given only for stepwaves in the 2.44 metre shock tube because a decaying wave driver is not yet available for use.

Reference 1 describes a vented RWE in use at this facility. More recent experiments have shown the use of the RWE to give quite acceptable results when the RWE is adjusted more accurately. See Figure 27 for pressure-time records from Station 87, 21.7 m from the open end of the shock tube. These records compare quite well with those from the 0.57 m and 5.07 cm shock tube experiments.

Time did not permit a multiple bars RWE to be designed and tested on the 2.44 metre shock tube.

## V. ANALYSIS OF RESULTS

The results in the form of overpressure versus time have been presented for the various RWE concepts tested. A medium overpressure of 50 kPa was selected for direct comparisons and Station 2 was selected for the reflection-rarefaction wave match-up.

### A. Vented Area versus Test Station Pressure

There is a direct correlation of the vented area at the end of the shock tube and the peak overpressure at the test station to achieve a good rarefaction wave elimination. The vented area may be the open area around the side of the tube due to the stand-off distance as with a solid plate RWE, or a combination of the stand-off and the straight through vented area as in the bar or vented foam RWE's. Curves have been developed depicting the vent area ratio; i.e., the total vented area divided by the shock tube cross-section area versus the test station peak overpressure. This relationship is presented in Figure 28. The values were developed from the 5.08 cm shock tube, but when scaled up to the 2.44 m shock tube, the relationships were found to be valid. There is some scatter in the individual data points for a specific RWE concept, but the lower curve in Figure 28 tends to represent the solid RWE concepts where the venting is due to stand-off only. The upper curve represents the RWE concepts where there is a straight through venting plus the stand-off, similar to the multiple bars and vented foam concepts.

### B. Direct Comparison of RWE Concepts

The three major candidate RWE concepts are the solid plate foam, the vented foam, and the multiple bars. One of the important functions of a RWE is to eliminate the rarefaction wave from the open end of the test section and the associated increase in dynamic pressure. The shock wave overpressure and the stagnation pressure were recorded at Station 2 at the 50 kPa input pressure for the candidate RWE concepts.

In Figure 29A the shock overpressure (PS) is subtracted from the stagnation pressure (STAG) to give the dynamic pressure for a long test section. This is presented as a baseline for comparing the effectiveness of the three RWE concepts. This is a very difficult pressure range to make

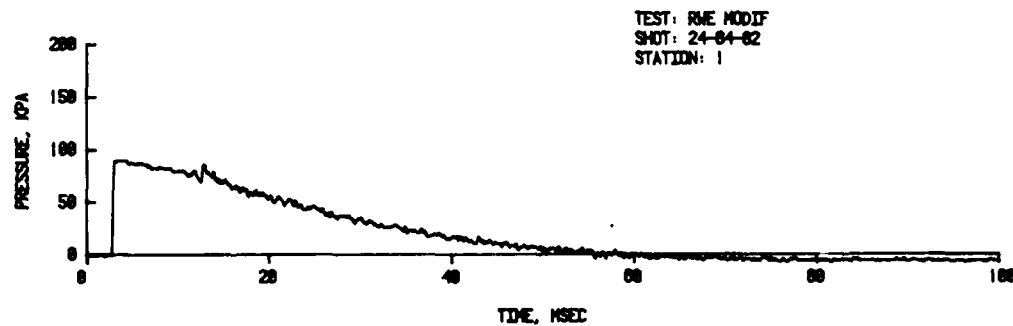
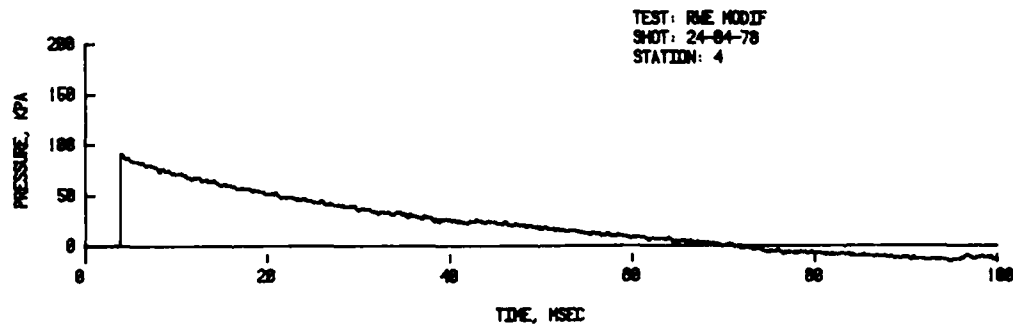
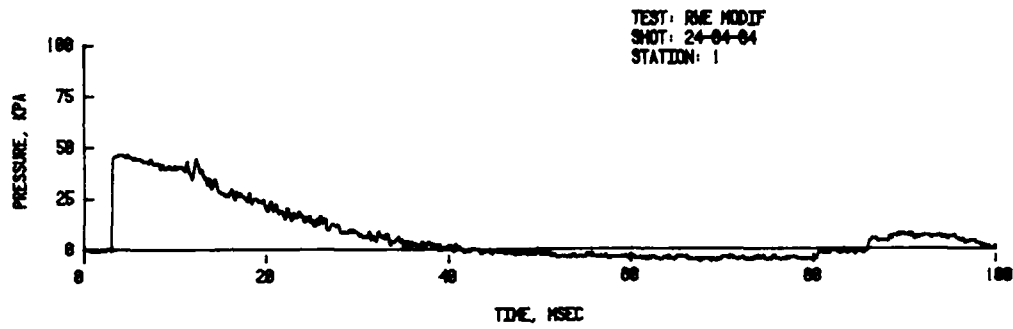
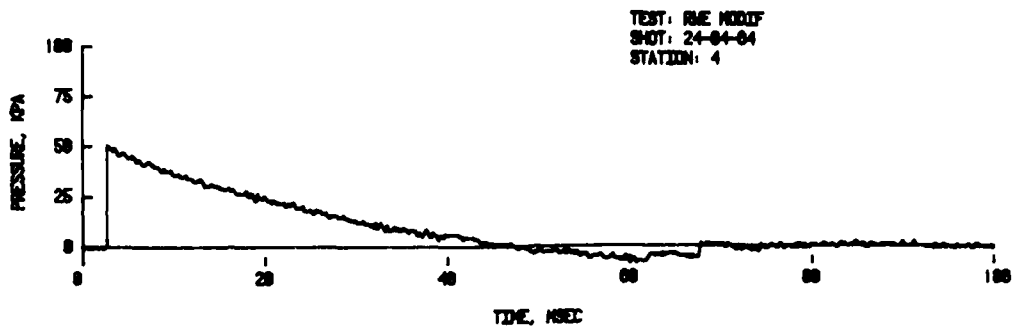

Figure 26. Pressure-Time Records, Multiple Bars RWE, Input Pressures, 50 and 100 kPa

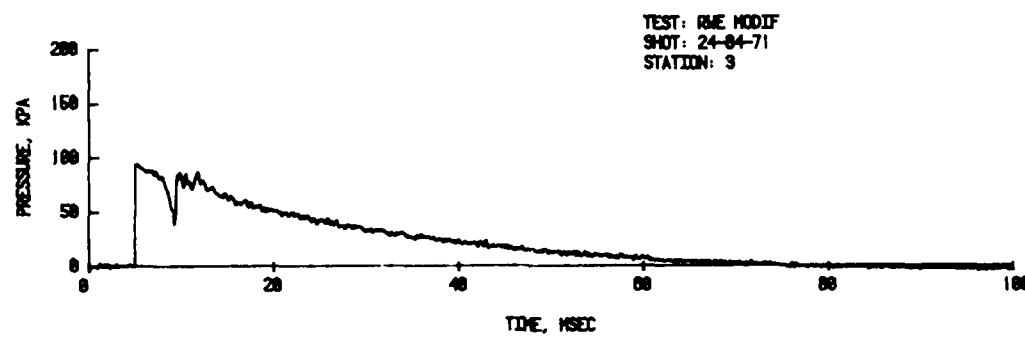
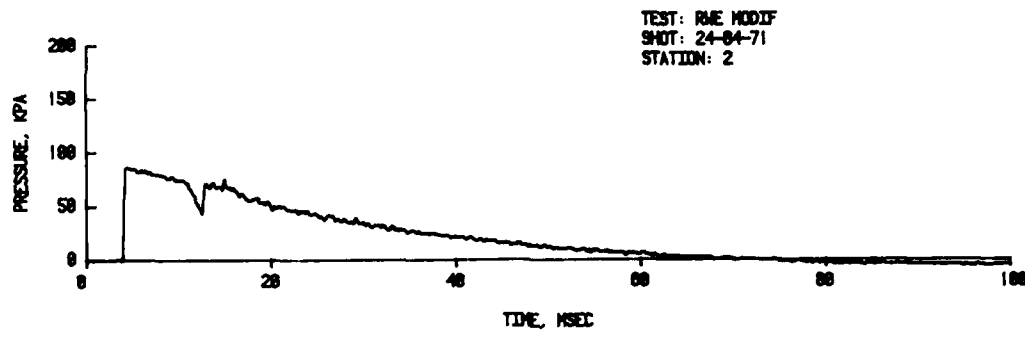
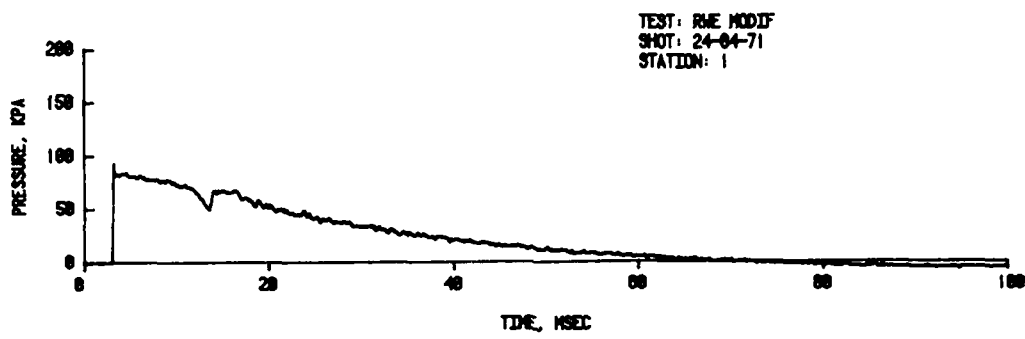
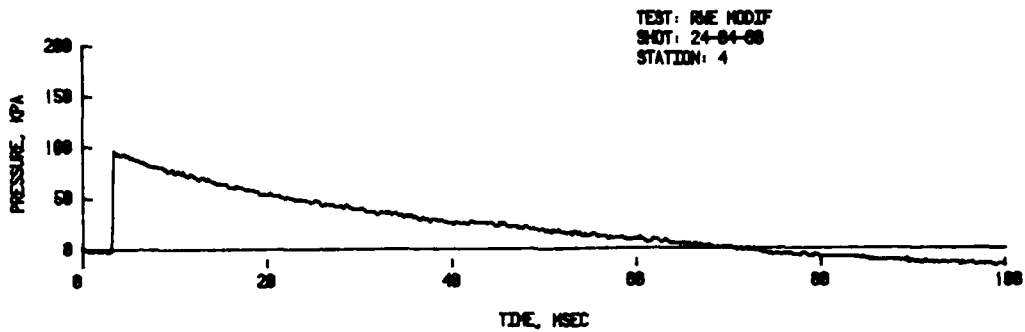

Figure 25. Pressure Time Records, Vented Foam RWE, 100 kPa Input Pressure, 0.57 Metre Shock Tube

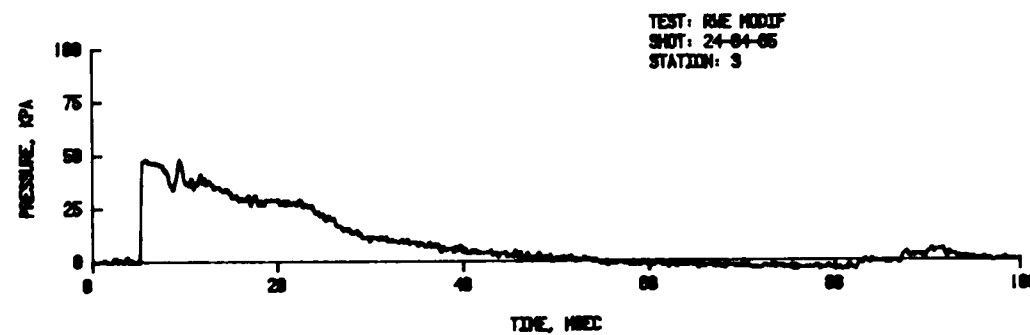
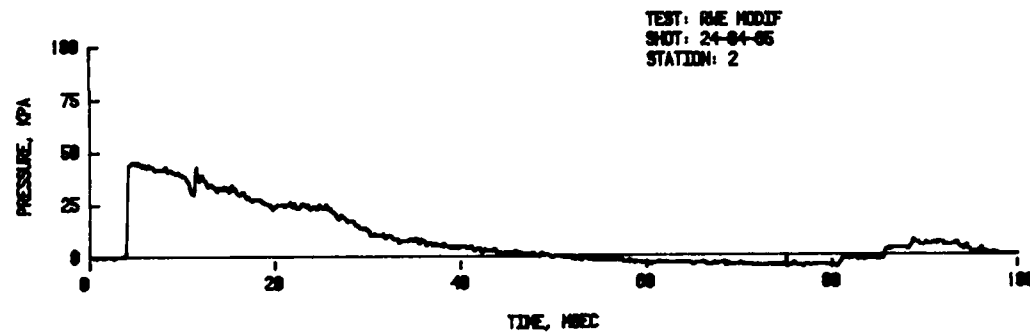
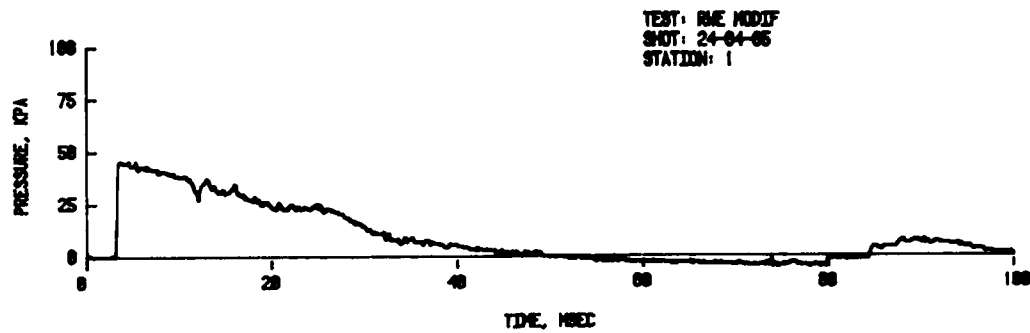
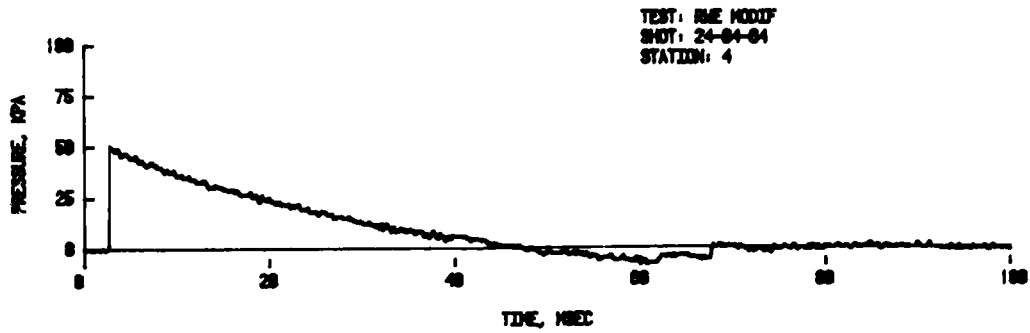

Figure 24. Pressure-Time Records, Vented Foam FWE, 50 kPa Inlet Pressure, 0.57 Metre Shock Tube

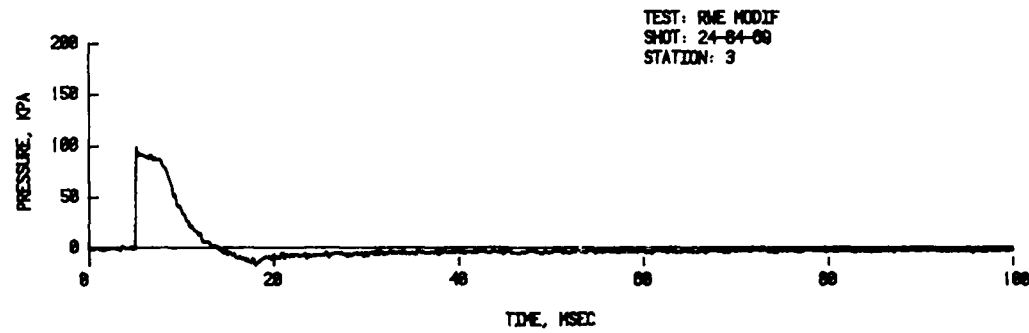
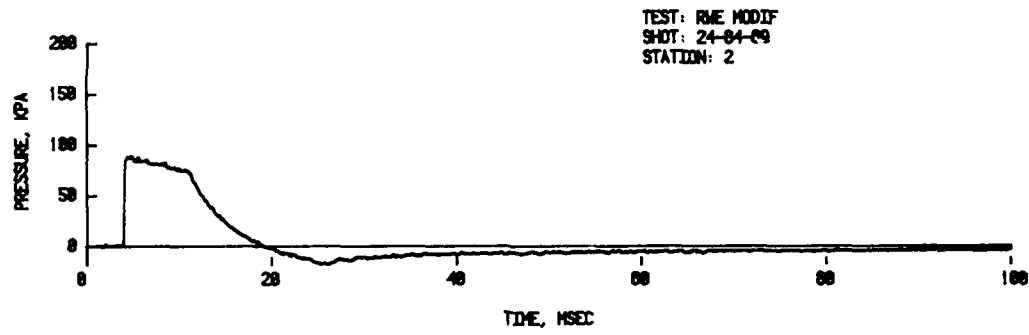
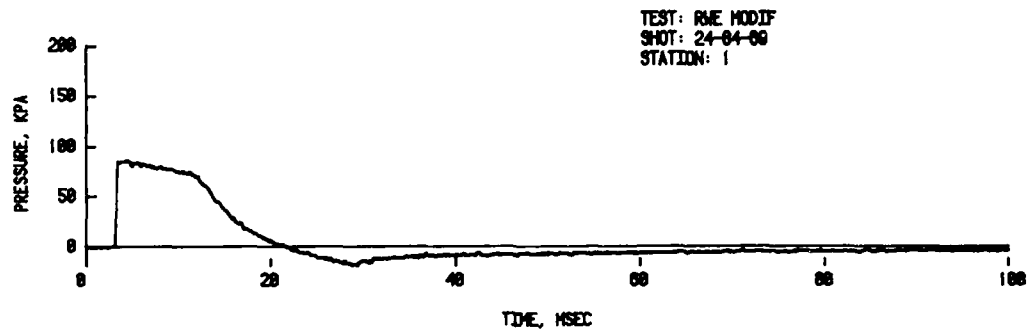
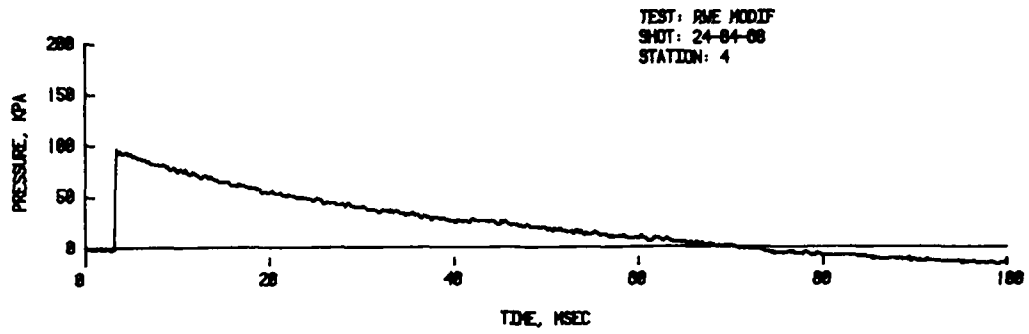

Figure 23. Pressure-Time Records, No BPP, 100 kPa Input Pressure, 0.17 Metre Shock Tube

DISTRIBUTION LIST

<u>No. of Copies</u>	<u>Organization</u>	<u>No. of Copies</u>	<u>Organization</u>
12	Administrator Defense Technical Info Center ATTN: DTIC-DDA Cameron Station Alexandria, VA 22314	1	Chairman DoD Explosives Safety Board ATTN: Tom Zaker Rm 856-C, Hoffman Bldg. I 2461 Eisenhower Avenue Alexandria, VA 22331
4	Director of Defense Research and Engineering ATTN: DD/TWP DD/S&SS DD/I&SS AD/SW Washington, DC 20301	1	HQDA (DAMA-AR, NCB Division) Washington, DC 20310
3	Director Defense Advanced Research Project Agency ATTN: Technical Library NMRO PMO 1400 Wilson Boulevard Arlington, VA 22209	1	Commander US Army Ballistic Missile Defense Program Office ATTN: DACS-SAE-S, J. Shea 5001 Eisenhower Avenue Alexandria, VA 22333
1	Director Defense Intelligence Agency ATTN: Mr. C. Wiehle Washington, DC 20301	1	Commander US Army Ballistic Missile Defense Systems Command ATTN: SSC-LH P.O. Box 1500 Huntsville, AL 35807
8	Director Defense Nuclear Agency ATTN: STIL (Tech Lib, 2 cys) SPSS, Dr. K. Goering Dr. G. Sevin, 2 cys DDST, COL Frankhouser (2 cys) SPAS, Mr. D. Kohler Washington, DC 20305	3	Director US Army Advanced BMD Technology Center ATTN: Mr. B. E. Kelley Mr. M. Capps Mr. Marcus Whiteford P.O. Box 1500 Huntsville, AL 35807
2	Commander Field Command, DNA ATTN: FCTMOF Kirtland AFB, NM 87115	2	Commander US Army Engineer Waterways Experiment Station ATTN: Library W. Flateau P.O. Box 631 Vicksburg, MS 39180
		1	Commanding General Fleet Marine Force, Atlantic ATTN: G-4 (NSAP) Norfolk, VA 23511

DISTRIBUTION LIST

<u>No. of Copies</u>	<u>Organization</u>	<u>No. of Copies</u>	<u>Organization</u>
1	Commander US Army Materiel Command ATTN: AMCDRA-ST 5001 Eisenhower Avenue Alexandria, VA 22333	1	Commander US Army Communications- Electronics Command ATTN: AMSEL-ED Fort Monmouth, NJ 07703
1	Commander Armament R&D Center US Army AMCCOM ATTN: SMCAR-TDC Dover, NJ 07801	1	Commander US Army Electronics Research and Development Command Technical Support Activity ATTN: DELSD-L Fort Monmouth, NJ 07703-5301
1	Commander Armament R&D Center US Army AMCCOM ATTN: SMCAR-TSS Dover, NJ 07801	1	Commander US Army Missile Command ATTN: AMSMI--R Redstone Arsenal, AL 35898
1	Commander US Army Armament, Munitions and Chemical Command ATTN: SMCAR-ESP-L Rock Island, IL 61299	1	Commander US Army Missile Command ATTN: AMSMI-YDL Redstone Arsenal, AL 35898
1	Director Benet Weapons Laboratory Armament R&D Center US Army AMCCOM ATTN: SMCAR-ICB-TL Watervliet, NY 12189	1	Commander US Army Tank Automotive Command ATTN: AMSTA-TSL Warren, MI 48090
1	Commander US Army Aviation Research and Development Command ATTN: AMSAV-E 4300 Goodfellow Blvd St. Louis, MO 63120	1	Director US Army TRADOC Systems Analysis Activity ATTN: ATAA-SL White Sands Missile Range, NM 88002
1	Director US Army Air Mobility Research and Development Laboratory Ames Research Center Moffett Field, CA 94035	1	Commandant US Army Infantry School ATTN: ATSH-CD-CSO-OR Fort Benning, GA 31905
1	Air Force Armament Laboratory ATTN: AFATL/DLODL Eglin AFB, FL 32542-5000	1	Commander US Army Development & Employment Agency ATTN: MODE-TED-SAB Fort Lewis, WA 98433

DISTRIBUTION LIST

<u>No. of Copies</u>	<u>Organization</u>	<u>No. of Copies</u>	<u>Organization</u>
3	Commander US Army Nuclear & Chemical Agency ATTN: AICN-W CDINS-E Technical Library 7500 Backlick Rd, Bldg. 2073 Springfield, VA 22150	1	HQ USAFSC (DLCAW/SDOA, Tech Lib) Andrews AFB Washington, DC 20331
		1	AFOSR (OAR) Bolling AFB, DC 20332
		1	KADC (Document Lib, FMTLD) Griffiss AFB, NY 13441
1	HQDA DAMA-ART-M Washington, DC 20310	5	AFWL/SUL (CA, Dr. A. Guenther; DYT, 3 cys) Kirtland AFB, NM 87117
2	Office of Naval Research Department of the Navy ATTN: T. Quinn, Code 461 J. L. Warner, Code 461 Arlington, VA 22217	1	SAMSO (Library) P.O. Box 92960 Los Angeles, CA 90009
		3	AFTC (K. Rosenlof; R. McBride; G. Leies) Patrick AFB, FL 32925
4	Commander Naval Surface Weapons Center ATTN: Code 1224, Navy Nuclear Programs Office Code 241 Code 730, Tech Library; J. Pittman Silver Springs, MD 20910	1	AFML (G. Schmitt, MAS) Wright-Patterson AFB, OH 45433
1	Commander Naval weapons Evaluation Fac ATTN: Document Control Kirtland AFB, NM 87117	2	Headquarters Energy Research & Development Administration Dept of Military Application ATTN: R&D Branch Library Branch, G-043 Washington, DC 20545
1	Officer in Charge (Code L31) Civil Engineering Laboratory Naval Construction Battalion Center ATTN: Dr. W.A. Shaw, Code L31 Port Hueneme, CA 93041	1	Director Los Alamos Scientific Lab ATTN: Tech Library P.O. Box 1663 Los Alamos, NM 87554
3	Commander Naval Research Laboratory ATTN: M. Persechino G. Cooperstein Tech Lib, Code 2027 Washington, DC 20375	1	Director National Aeronautics and Space Administration ATTN: Code 04.000 Langley Research center Langley Station Hampton, VA 23365

DISTRIBUTION LIST

<u>No. of Copies</u>	<u>Organization</u>	<u>No. of Copies</u>	<u>Organization</u>
1	Director NASA Scientific & Technical Information Facility ATTN: SAK/DL P.O. Box 8757 Baltimore/Washington International Airport, MD 21240	1	Effects Technology, Inc. ATTN: E. Anderson 5383 Hollister Ave Santa Barbara, CA 93111
1	National Academy of Sciences Advisor Committee on Civil Defense ATTN: Dr. Donald Groves 2101 Constitution Avenue, NW Washington, DC 20418	1	KAMAN - TEMPO ATTN: DASAC 816 State Street, Drawer QQ Santa Barbara, CA 93101
1	Aerospace Corporation ATTN: Tech Information Svcs Building 105, Rm 2220 P.O. Box 92957 Los Angeles, CA 90009	1	General Electric Co.-TEMPO 7800 Marble Avenue, NE Suite 5 Albuquerque, NM 87110
1	Agbabian Associates ATTN: Dr. J. Malthan 250 N. Nash Street El Segundo, CA 90245	1	H-Tech Laboratories, Inc. ATTN: B. Hartenbaum P.O. Box 1686 Santa Monica, CA 90406
1	AVCO Government Products Grp ATTN: Dr. W. Bade 201 Lowell Street Wilmington, MA 01887	1	Hughes Helicopter Company Systems Development Lab ATTN: Dr. A. Puckett Centinela & Teale Streets Culver City, CA 90230
1	AVCO-Everett Research Lab ATTN: Technical Library 2385 Revere Beach Parkway Everett, MA 02149	1	Ion Physics Corporation ATTN: Technical Library South Bedford Street Burlington, MA 01803
1	John A. Blume & Associates ATTN: Dr. John A. Blume 100 Jessie Street San Francisco, CA 94105	1	Kaman Sciences Corporation ATTN: Dr. Donald Sachs 2001 Jefferson Davis Highway Suite 703, Crystal Plaza #1 Arlington, VA 22202
1	Center for Planning and Research Inc. ATTN: John R. Rempel 2483 East Bayshore Road Palo Alto, CA 94303	1	Kaman Avidyne, Division of Kaman Sciences ATTN: Dr. J. Ray Ruetenik 83 2nd Ave, NW Industrial Park Burlington, MA 01830
		1	KTECH Corporation ATTN: Dr. Donald V. Keller 911 Pennsylvania NE Albuquerque, NM 87110

DISTRIBUTION LIST

<u>No. of Copies</u>	<u>Organization</u>	<u>No. of Copies</u>	<u>Organization</u>
1	Lockheed Missiles & Space Co. Div of Lockheed Aircraft Corp. ATTN: J. Nickell Sunnyvale, CA 94086	3	R&D Associates ATTN: Technical Library Jerry Carpenter Allen Kuhl P.O. Box 9695 Marina del Rey, CA 90291
1	Management Science Associates ATTN: Kenneth Kaplan P.O. Box 239 Los Altos, CA 94022	1	Sandia National Laboratory ATTN: Dr. J. Kennedy Albuquerque, NM 87115
1	Martin Marietta Aerospace Orlando Division ATTN: A. Ossin P.O. Box 5837 Orlando, FL 32805	2	Science Applications, Inc. ATTN: Joseph McGahan Dr. John Cockayne 1710 Goodridge Drive P.O. Box 1313 McLear, VA 22102
1	Maxwell Laboratories, Inc. ATTN: A. Kolb 9244 Balboa Avenue San Diego, CA 92123	1	AFML (D. Schmidt, MBC) Wright-Patterson AFB, OH 45433
1	McDonnell Douglas Astronautics Corporation 5301 Bolsa Avenue Huntington Beach, CA 92647	1	Systems, Science & Software ATTN: Technical Library P.O. Box 1620 La Jolla, CA 92037
1	H. L. Murphy Associates Box 1727 San Mateo, CA 94401	1	Teledyne-Brown Engineering Cummings Research Park Huntsville, AL 35807
1	Patel Engineering P.O. Box 3531 Huntsville, AL 35810	1	Union Carbide Corporation Oak Ridge National Lab ATTN: Technical Library P.O. Box X Oak Ridge, TN 37830
1	Philco Ford Corporation Aeronutronic Division ATTN: L. K. Goodwin Fort Road Newport Beach, CA 92663	1	Battelle Memorial Institute ATTN: Technical Library 505 King Avenue Columbus, OH 43201
2	Physics International Company ATTN: Document Control Fred Sauer 2700 Merced Street San Leandro, CA 94577	1	Director Applied Physics Laboratory The Johns Hopkins University Johns Hopkins Road Laurel, MD 20707

DISTRIBUTION LIST

<u>No. of Copies</u>	<u>Organization</u>	<u>No. of Copies</u>	<u>Organization</u>
1	Lovelace Research Institute ATTN: Dr. D. Richmond P.O. Box 5890 Albuquerque, NM 87108	2	University of Denver Denver Research Institute ATTN: Mr. John Wisotski P.O. Box 10127 Denver, CO 80210
1	Massachusetts Institute of Technology Aerophysics Laboratory 77 Massachusetts Avenue Cambridge, MA 02139	1	J. D. Haltiwanger Consulting Services B106a Civil Engineering Building 208 N. Romine St. Urbana, IL 61801
1	New Mexico Institute of Mining and Technology ATTN: Mr. P. McClain Socorro, NM 87801	1	University of Maryland Department of Physics ATTN: Dr. E. Oktay College Park, MD 20740
1	Northwestern Michigan College ATTN: Prof D. C. Kennard, Jr. Traverse City, MI 49584	1	The University of New Mexico Eric H. Wang Civil Engineering Research Facility ATTN: Technical Library University Station, Box 188 Albuquerque, NM 87106
1	Southwest Research Institute ATTN: Dr. W. Baker 8500 Culebra Road San Antonio, TX 78228	1	University of Oklahoma Department of Physics ATTN: Prof R. Fowler 440 W. Brooks, Rm 131 Norman, OK 73069
1	Research Institute of Temple University ATTN: Technical Library Philadelphia, PA 19144		<u>Aberdeen Proving Ground</u>
1	Texas Tech College Dept of Civil Engineering ATTN: Mr. Joseph E. Minor Lubbock, TX 79408		Dir, USAMSAA ATTN: AMKSY-D AMKSY-MP, H. Cohen
1	University of Arkansas Department of Physics ATTN: Prof O. Zinke Fayetteville, AR 72701		Cdr, USATECOM ATTN: AMSTE-TO-F
1	University of California Lawrence Livermore Lab ATTN: Technical Library Dr. D. N. Montan P.O. Box 808 Livermore, CA 94550		Cdr, CRDC, AMCCOM ATTN: SMCCR-SPS-IL SMCCR-MU SMCCR-RSP-A

USER EVALUATION SHEET/CHANGE OF ADDRESS

This Laboratory undertakes a continuing effort to improve the quality of the reports it publishes. Your comments/answers to the items/questions below will aid us in our efforts.

1. BRL Report Number \_\_\_\_\_ Date of Report \_\_\_\_\_

2. Date Report Received \_\_\_\_\_

3. Does this report satisfy a need? (Comment on purpose, related project, or other area of interest for which the report will be used.) \_\_\_\_\_  
\_\_\_\_\_  
\_\_\_\_\_

4. How specifically, is the report being used? (Information source, design data, procedure, source of ideas, etc.) \_\_\_\_\_  
\_\_\_\_\_  
\_\_\_\_\_

5. Has the information in this report led to any quantitative savings as far as man-hours or dollars saved, operating costs avoided or efficiencies achieved, etc? If so, please elaborate. \_\_\_\_\_  
\_\_\_\_\_  
\_\_\_\_\_

6. General Comments. What do you think should be changed to improve future reports? (Indicate changes to organization, technical content, format, etc.) \_\_\_\_\_  
\_\_\_\_\_  
\_\_\_\_\_

CURRENT ADDRESS

\_\_\_\_\_  
Name  
\_\_\_\_\_  
Organization  
\_\_\_\_\_  
Address  
\_\_\_\_\_  
City, State, Zip

7. If indicating a Change of Address or Address Correction, please provide the New or Correct Address in Block 6 above and the Old or Incorrect address below.

OLD ADDRESS

\_\_\_\_\_  
Name  
\_\_\_\_\_  
Organization  
\_\_\_\_\_  
Address  
\_\_\_\_\_  
City, State, Zip

(Remove this sheet along the perforation, fold as indicated, staple or tape closed, and mail.)

FOLD HERE

Director  
Army Ballistic Research Laboratory  
ATTN: AMXBR-OD-ST  
Aberdeen Proving Ground, MD 21005-5066



NO POSTAGE  
NECESSARY  
IF MAILED  
IN THE  
UNITED STATES

OFFICIAL BUSINESS  
PENALTY FOR PRIVATE USE, \$300

**BUSINESS REPLY MAIL**  
FIRST CLASS PERMIT NO 12062 WASHINGTON, DC  
POSTAGE WILL BE PAID BY DEPARTMENT OF THE ARMY

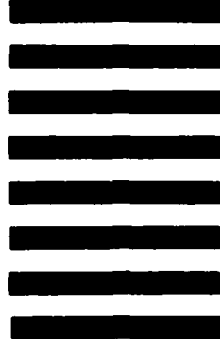

Director  
US Army Ballistic Research Laboratory  
ATTN: AMXBR-OD-ST  
Aberdeen Proving Ground, MD 21005-9989

FOLD HERE

**END**

**FILMED**

5-85

**DTIC**