

AD-A153 382

GI TRACT EXPERIMENTAL STUDY(U) JAYCOR SAN DIEGO CA  
J H YU JUL 83 DAMD17-83-C-3867

1/1

UNCLASSIFIED

F/G 6/16

NL

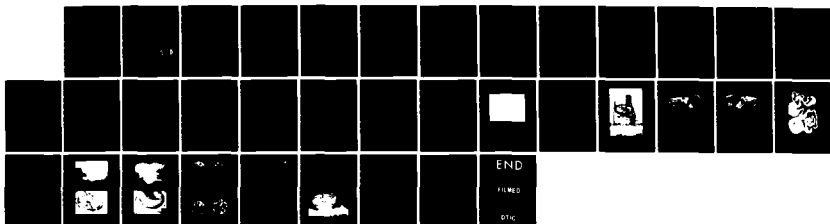

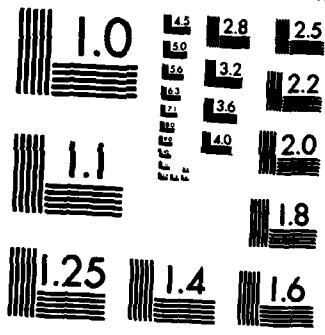

MICROCOPY RESOLUTION TEST CHART  
NATIONAL BUREAU OF STANDARDS-1963-A

AD-A153 382

AD

③

# GI TRACT EXPERIMENTAL STUDY

Final Report

by  
James H.-Y. Yu  
Edward J. Vasel

July 1983

Supported by  
U. S. ARMY MEDICAL RESEARCH AND DEVELOPMENT COMMAND  
Fort Detrick, Frederick, Maryland 21701-5012

Contract No. DAMD17-83-C-3067

JAYCOR  
11011 Torreyana Road  
San Diego, California 92121

DTIC  
ELECTE  
MAY 06 1985  
S D E

Approved for public release; distribution unlimited.

The findings in this report are not to be construed as an official Department of the Army position unless so designated by other authorized documents.

DTIC FILE COPY

REPORT DOCUMENTATION PAGE		READ INSTRUCTIONS BEFORE COMPLETING FORM
1. REPORT NUMBER	2. GOVT ACCESSION NO.	3. RECIPIENT'S CATALOG NUMBER
4. TITLE (and Subtitle) GI Tract Experimental Study		5. TYPE OF REPORT & PERIOD COVERED Final Report (1 Feb. 1983-31 May 1983)
		6. PERFORMING ORG. REPORT NUMBER
7. AUTHOR(s) James H. Yu		8. CONTRACT OR GRANT NUMBER(s) DAMD17-83-C-3067
9. PERFORMING ORGANIZATION NAME AND ADDRESS JAYCOR 11011 Torreyana Road San Diego, California 92121		10. PROGRAM ELEMENT, PROJECT, TASK AREA & WORK UNIT NUMBERS 61102A.3M161102BS10.CG.106
11. CONTROLLING OFFICE NAME AND ADDRESS US Army Medical Research and Development Command Fort Detrick, Frederick, Maryland 21701-5012		12. REPORT DATE July 1983
		13. NUMBER OF PAGES 36
14. MONITORING AGENCY NAME & ADDRESS (if different from Controlling Office)		15. SECURITY CLASS. (of this report) Unclassified
		15a. DECLASSIFICATION/DOWNGRADING SCHEDULE
16. DISTRIBUTION STATEMENT (of this Report) Approved for public release; distribution unlimited		
17. DISTRIBUTION STATEMENT (of the abstract entered in Block 20, if different from Report)		
18. SUPPLEMENTARY NOTES		
19. KEY WORDS (Continue on reverse side if necessary and identify by block number) GI tract Blast injury Rabbit		
20. ABSTRACT (Continue on reverse side if necessary and identify by block number) A series of scoping tests were conducted to test the feasibility of using an isolated GI tract for blast injury study. Evidence suggests that carefully controlled preparation is essential in maintaining the natural state of the GI. A number of controlling parameters that directly coupled with the GI injury threshold were identified. Quantification of these parameters is necessary to gain a better understanding of the GI injury mechanism.		

*gastrointestinal  
Tract*

**SUMMARY**

*A.S. Summary*

An earlier model intestine test indicated that there was a direct correlation between surface deformation and bubble locations. Such deformation was the result of local stress concentration and believed to be the cause of (GI) blast injury. ~~The present work~~ was intended to determine the connection between injury and bubble sites in a real GI specimen.

An isolated GI tract placed in a transparent test chamber would allow us to closely observe the blast/GI interaction process. The feasibility of using an isolated GI tract as the test specimen, however, needed to be verified. Furthermore, since there were numerous parameters that could contribute to the GI blast injury, it would be desirable to identify the ones that had the most direct impact on the injury threshold.

The result from this series of tests indicated that the approach of using an isolated GI tract was a viable one when the complete GI loop was used in the test. Moisture and temperature control were found to be crucial in maintaining the GI material properties, both during the test and during specimen preparation. Furthermore, it was found that the following parameters had direct impact on the GI blast injury: the amount of air in the GI, GI internal pressure, vascular pressure, material strength, blast loading magnitude, and the number and rate of the blast applied. Three types of blast injuries were identified: mucosal bleeding, serosal bleeding, and wall rupture.

Based on these findings, it was recommended that a more in-depth study on the causal relationships between those identified parameters and blast injuries be carried out. Both high speed movies and pressure measurements should be used to acquire the information to help understand the mechanism of GI blast injury.

Accession For	
NTIS GRA&I	<input checked="" type="checkbox"/>
DTIC TAB	<input type="checkbox"/>
Unannounced	<input type="checkbox"/>
Justification	
By _____	
Distribution/	
Availability Codes	
Dist	Avail and/or Special
<b>A-1</b>	



## FOREWORD

In conducting the research described in this report, the investigators adhered to the "Guide for the Care and Use of Laboratory Animals," prepared by the Committee on Care and Use of Laboratory Animals of the Institute of Laboratory Animal Resources, National Research Council (DHEW Publication No. (NIH) 78-23, Revised 1978).

**TABLE OF CONTENTS**

	<u>Page</u>
1. INTRODUCTION .....	1
2. EXPERIMENTAL FACILITY .....	3
2.1 Design Considerations .....	3
2.2 Test Facility and Instrumentation .....	3
3. TEST SPECIMEN PREPARATION AND EXPERIMENTAL PROCEDURES .....	5
4. GI TRACT BLAST INJURIES .....	7
5. CONTROLLING PARAMETERS OF GI INJURY .....	9
5.1 Air Bubble .....	9
5.2 Internal Pressure of GI Tract .....	9
5.3 Vascular Pressure .....	10
5.4 Material Strength of GI Tract and Blood Vessels .....	10
5.5 Impact Loading .....	11
5.6 Repeated Loading .....	11
6. CONCLUDING REMARKS .....	13

## LIST OF FIGURES

	<u>Page</u>
Figure 1. A typical impact signal .....	15
Figure 2. GI tract blast overpressure test chamber .....	16
Figure 3. Test chamber mounted in constant temperature bath .....	17
Figure 4. Internal organs of a rabbit .....	18
Figure 5. GI tract of a rabbit .....	20
Figure 6. Isolated GI tract test sections .....	21
Figure 7. Complete GI tract with tied-off test sections .....	21
Figure 8. Transfer and support basket .....	22
Figure 9. Contusion injury .....	22
Figure 10. Contusion injuries and local wall rupture .....	23
Figure 11. GI wall rupture injury .....	23
Figure 12. Effect of multiple shots on GI tract injury .....	24
Figure 13. Typical cross-section of the gut .....	26
Figure 14. GI tract bursting pressure test .....	26

## 1. INTRODUCTION

It has been established that a single, strong blast overpressure (BOP) will induce damage to lung, larynx, and gastrointestinal tract. It is also known that repeated blast would cause similar types of injury at lower BOP levels. Since the affected organs are all gas-containing, it has been hypothesized that the presence of air bubbles was necessary for blast induced stress concentration and the observed injury.

Though blast-related pulmonary injury has attracted much attention and research effort, little progress has been made with regard to GI tract injury. Since field tests conducted at Lovelace ITRI suggested that GI tract injury has a lower threshold level, there is more concern regarding the nature of the mechanism.

As a first step in understanding the injury mechanism and to provide some direct visual evidence on the relationship between the presence of air bubbles and the location of GI injury, JAYCOR initiated an in-house experimental program. The objective was to study whether there was a direct correspondence between surface deformation and bubble location under blast loading. In this study model intestines made of transparent polyethylene membrane were filled with water or toothpaste to simulate different GI contents. A predetermined quantity of air was injected into each model to simulate a gas bubble.

The test samples were installed in a water-filled test chamber and a water jet impactor developed by JAYCOR was used to deliver the impact. Interaction between impact loading and surface deformation was recorded by high speed movies for subsequent analysis. It was shown that there were considerable surface deformations at the bubble location and that the deformation propagated out radially as ripples on the tube wall. The more viscous model contents (toothpaste) had a much greater damping effect, forcing the deformation to concentrate in a more limited region than that of the less viscous water. It was concluded that the locations of air bubbles do indeed match the sites of stress concentrations.

The same phenomenon was also illustrated by numerical modeling. When appropriate choices of tissue properties and loading characteristics were given, surface deformation was found to take place at the bubble site.

With the causal relationship between bubble location and surface deformation confirmed for model intestines, the procedure was extended in this project to actual GI tract sections. Since there are many parameters involved, it was decided to conduct a scoping study with the specific objectives:

- Test the feasibility and establish the specific procedures required for conducting GI blast loading tests in a small, water-filled test chamber.
- Identify the key parameters and their causal relationships with GI injury.
- Carry out some preliminary tests in terms of these parameters.



## 2. EXPERIMENTAL FACILITY

### 2.1 DESIGN CONSIDERATIONS

To facilitate laboratory GI tract study, the test setup should have the following capabilities: reproduce the GI tract blast signal, deliver impact loadings in the appropriate range, make repeated shots, and provide visual information on blast/GI interaction processes.

The blast signal in the GI tract was generated by direct impact on a nylon-reinforced neoprene diaphragm in the test chamber. Different blast intensities were achieved by varying the impact intensity. Actual pressure received by the GI tract was monitored by a wall-mounted pressure transducer. A typical blast signal in the test chamber is shown in Figure 1.

A transparent cover for the test chamber allows a full view of the GI tract. The interaction processes were observed through this cover and recorded by a high speed movie camera while the post-shot damage was recorded by still photographs.

A major concern regarding the test procedure was possible autolysis if the time between isolation of tissue from the body to final blast test was too long. A time limit of 10 minutes was suggested by Dr. Robert Hoyt of WRAIR as the upper bound. The tests carried out in this series were kept in this limit by using the simplified test setup and following a GI preparation procedures outlined in the next section.

To reduce the effect of temperature gradient on GI tract during preparation and during tests, saline solution maintained at body temperature was used in both situations.

### 2.2 TEST FACILITY AND INSTRUMENTATION

Based on the considerations given above, an 8-inch diameter horizontal impaction, top-observation-window test chamber was designed and fabricated. Figure 2 is an engineering drawing of the test chamber and Figure 3 is a photograph of the test chamber installed in the constant temperature bath. The temperature of the bath was maintained by a Haake temperature control circulator. Using this system, the temperature could be maintained within  $\pm 0.2^{\circ}\text{C}$  of the set temperature.

A PCB piezoelectric pressure transducer was used to monitor the pressure signals in the test chamber. It has a rise time of 2  $\mu\text{s}$  and a resonant frequency of 500 KHz, sufficient to resolve the blast wave information in the test chamber.

The transient response of the GI tract under impact loading was captured by means of a Fastex high speed movie camera. A frame rate of 2500 per second was found to be sufficient to resolve the interaction process.

Though initially a single valve jet impactor was planned for delivering the impulse, threshold pressure for single shot injury was found to be higher than the present impactor capability. Mechanical impacts of the target diaphragm were therefore used for all subsequent tests.



### 3. TEST SPECIMEN PREPARATION AND EXPERIMENTAL PROCEDURES

Rabbits were chosen as the test animal in this series of tests. The GI tract configuration in the animal is shown in Figure 4. Figure 5 shows a complete loop with various portions of the GI tract grouped separately. Though sections of intestine were originally planned to be the test specimens (Figure 6), it was found that these specimens had little blood reserve and lost their "liveliness" quickly. Test specimens prepared under these conditions would require a much higher and unrealistic impact pressure to generate contusion injuries.

An alternative approach was to tie off the sections to be tested and make all the necessary preparations with the whole GI tract intact. The blast test would be carried out with the whole GI tract immediately after separation from the animal. This approach would allow a large amount of blood to be retained in the mesentarium and hence simulate more closely the natural state of the GI tract. The test specimen prepared using this approach is shown in Figure 7.

More specifically, the preparation involves the selection and tie-off of the test sections in situ. To begin with, one end would be tied off completely to prevent any leakage while it was loosely tied at the other end. A hypodermic needle was then used to inject a predetermined amount of saline solution and air bubble from the loose end. The test section would then be tied off the moment the needle was removed. A nominal intestine length of 5 in. was chosen for the tests. As will be discussed later, injection of saline into the test section was found to be necessary to induce any injury at a reasonable impact pressure.

It is crucial to keep the exposed GI tract both moist and at normal body temperature during preparation. To do this, the body of the anesthetized rabbit was submerged in a warm saline solution tub. An auxiliary heat lamp was used to keep the exposed parts warm. A chilled and dried gut tends to get a tougher texture. On the other hand, too high a temperature discolors the test specimen. Both would be evidence of change in the natural properties of the test section.

Heartbeat and blood circulation would continue throughout the preparation period until final tie-off of the test sections and separation of the whole bowel from the body. Extra care was exercised to occlude all blood vessels before dissection to prevent loss of blood from the test specimen.

A well executed preparation usually involves only a few cuts to separate the bowel from the animal body. Peristaltic movement would usually continue, even after many impacts in the test chamber.

The general procedure for a GI test usually involves the following steps:

1. Set up test chamber and start the circulation of the constant temperature bath.
2. Install and test pressure transducer for monitoring the impact loading.
3. Anesthetize the test rabbit with ketamine followed by injection of the combination of acepromazine and xylazine.

4. After the drugs take effect, secure the rabbit in the constant temperature saline solution operation tub.
5. Expose the GI tract.
6. Inject heparine I.V. in ear to reduce the likelihood of GI tract blood coagulation.
7. Select GI tract test sections; inject with predetermined amount of warm saline and air; tie off the test sections.
8. Isolate the entire GI tract and blood circulation system from the animal body.
9. Separate GI tract from body; place in test support basket (Figure 8) and place in test chamber.
10. Cover the test chamber with the transparent lid; displace excess chamber air bubble by injection of saline solution at bubble site; seal test chamber.
11. Deliver blast loading by mechanical impact.
12. Take high-speed movies, when necessary, to record the interaction between loading and deformation.
13. Take post-shot still pictures to document the injuries.

#### 4. GI TRACT BLAST INJURIES

Depending on the intensity and the number of repetitions there could be three different types of GI injuries. When the GI tract is subjected to a threshold blast, sporadic small bruise marks are observed on the GI wall (Figure 9). A higher blast loading would result in larger contusion regions. Such damage usually involves torn capillaries under the GI surface and is known as serosal bleeding.

Further increase in blast intensity results in local wall rupture (Figures 10 and 11). This phenomenon, however, was also observed when the GI tract was subjected to repeated impact even at a much lower blast pressure.

Though serosal bleeding was the most readily observable damage, mucosal bleeding was found to take place at a lower pressure level. This damage was indicated by the appearance of dark shadows under the GI wall.

One specific test was conducted to determine the mucosal bleeding threshold. Again, the GI tract was prepared following the normal procedure and impacted in the test chamber. After initial blast, contusion stains were noticed on a few GI test sections - the "threshold" condition of GI injury. However, when test sections were cut open, blood had already accumulated even in the sections without apparent external injury. This phenomenon, we believe, indicated that mucosal bleeding took place earlier than the externally observable contusion, and had a lower threshold value.

Though the actual case requires further careful verification, the conclusion appears plausible. As we know, nutrition absorption in the GI tract takes place at the molecular level and the tissue that separates nutrients and blood would also be very thin for ease of molecular exchange. (A cross-section of a typical intestine is shown in Figure 13.) Hence, unlike the blood vessels under the external wall, tearing and bleeding of the internal tissue could take place at a much lower impact pressure. If mucosal bleeding determines the injury threshold, a marker that is capable of detecting traces of blood in the GI tract could then be used as a useful indexing tool.

The actual injury progression is illustrated by the repeated blast results shown in Figure 12. Initially there were only traces of small contusion spots, however, as the number of impacts increased, the area of injury spread and the GI wall appeared to be weakened by fatigue, eventually leading to wall rupture. The rupture of the GI wall was evidenced by the accumulation of air bubbles and staining of nearby saline solution.

1  
2  
3  
4  
5  
6  
7  
8  
9  
10  
11  
12  
13  
14  
15  
16  
17  
18  
19  
20  
21  
22  
23  
24  
25  
26  
27  
28  
29  
30  
31  
32  
33  
34  
35  
36  
37  
38  
39  
40  
41  
42  
43  
44  
45  
46  
47  
48  
49  
50  
51  
52  
53  
54  
55  
56  
57  
58  
59  
60  
61  
62  
63  
64  
65  
66  
67  
68  
69  
70  
71  
72  
73  
74  
75  
76  
77  
78  
79  
80  
81  
82  
83  
84  
85  
86  
87  
88  
89  
90  
91  
92  
93  
94  
95  
96  
97  
98  
99  
100

## 5. CONTROLLING PARAMETERS OF GI INJURY

A number of controlling parameters that affected the degree of injury to the GI tract were identified. These are: the amount of air present, GI internal pressure, vascular pressure, material strength, impact loading, and the rate and number of blasts.

### 5.1 AIR BUBBLE

High-speed movies indicated that during blast, considerable expansion and contraction took place in the test sections with injected air whereas the test sections without air did not show this expansion and contraction. Since surface stress directly related to deformation, presence of air bubbles was apparently the major contributor to GI wall injury. Furthermore, for a given test section large air bubbles tend to have more volumetric variations during blast and thus are more conducive to injury.

Field tests conducted at Lovelace indicated that stomach, caecum and large colon were the general areas of blast injury. Since these are areas where gas tends to accumulate, the test chamber results seem to substantiate this conclusion. We noticed, however, that caecum and colon are less susceptible to injury and in most instances the small intestines were the sites of any substantial damage which occurred. This is perhaps the consequence of higher material strength and the effect of other parameters discussed below. Further tests with each parameter carefully controlled would be required to provide us more insight. A more direct approach to establish the one-to-one correspondence between air bubble location and serosal injury would be to identify the bubble locations with an ultrasonic device and impact the untreated test specimen and examine the damage subsequently.

### 5.2 INTERNAL PRESSURE OF GI TRACT

A flaccid gut with sufficient residual volume to accommodate the blast-induced gas bubble volume change is unlikely to exceed its stress limit and cause damage. On the other hand, a gut prestressed to its full capacity would easily exceed its material strength and cause tearing of blood vessels and cause bleeding.

To illustrate the effect of initial state of the gut on GI injury, the following test was conducted. Two sections of jejunum were chosen: one filled with 10 cc warm saline and one without. Both sections were then injected with an equal amount of air (5 cc). The test specimens were then impacted in the test chamber. As expected, only the one filled with saline was found to have contusion injury.

Since the only difference between the two test samples was the amount of residual volume available in the gut, it was concluded that, in addition to the presence of air, void ratio of the residual volume dictates the threshold of injury. In other words, if the GI tract is empty, blast loading damage would be unlikely since the pressure everywhere would be about the same. Similarly for the condition when it is filled with an incompressible fluid as its surrounding. On the other hand, if the gut is filled with fluid  $V_l$  and an air bubble  $V_g$ , then the available residual volume will be  $V_t - V_l - V_g = V$ . In this case, when the gut is subjected to an external dynamic pressure,  $V_g$  will

undergo a volume change corresponding to the pressure variation. The instantaneous pressure under which  $V_g$  expands to  $(V_g + V)$  will cause GI injury.

### 5.3 VASCULAR PRESSURE

During the course of this study, we found that if there was considerable blood loss during preparation, the test specimen would require a much higher pressure to inflict damage to the GI tract. This is probably because loss of blood would reduce the vascular pressure and therefore require higher loading to reach its tearing stress of the blood vessel. On the other hand, a prestressed artery or vein, similar to the prestressed gut discussed above, would reach its limit of material strength and exhibit local bursting/tearing at a lower level.

Since the actual blood vessels go through systolic and diastolic cycles as a result of dicrotic waves, depending on when the blast takes place during the pressure cycle the threshold magnitude for GI injury could be different. A carefully controlled experiment would be necessary to define the exact role blood pressure plays.

### 5.4 MATERIAL STRENGTH OF GI TRACT AND BLOOD VESSELS

Since the apparent GI injury involves essentially tearing of GI tissues and/or capillaries, high strength materials would require high blast level for damage to occur. In addition, the actual stress on the material also depends on the configuration of the subject.

For example, assuming the intestine is a thin-walled cylindrical tube, the mean tangential stress on the wall will be

$$\sigma = \frac{p \cdot r}{t}$$

where  $p$  is the internal pressure,  $r$  the tube radius and  $t$  the wall thickness. This proportionality between  $\sigma$  and  $r$  implies that a larger diameter gut will experience higher wall stress when the internal pressure and the wall thickness are the same. This means a larger gut should be more susceptible to injury. Preliminary tests, however, indicated that jejunum and duodenum test sections were more susceptible to damage and were usually the first to show signs of contusion injury. Since these were smaller diameter organs and should have lower stress, their lower damage threshold implies that they probably have lower material strengths.

A simple experiment was then carried out to test the material strength of each portion of the GI tract. As shown in Figure 14, the test section was connected to a saline solution bottle via a hypodermic needle. The static pressure in the gut was varied by raising or lowering the level of the bottle. It was found that the jejunum and duodenum had lower bursting strengths than that of ileum and caecum. The reason why field tests didn't show more damage in these sections was most likely due to the fact that, in general, they had less content (less internal pressure), and were less prone to gas bubble production.

Since material strength plays an important role in the establishment of injury threshold and also in our understanding of the underlying mechanism, it would be necessary to quantify this parameter for each portion of the GI

tract. A carefully controlled experiment would be necessary to provide such information.

### 5.5 IMPACT LOADING

Higher impact loading would induce more volumetric change in the GI tract and hence more likelihood of exceeding its material strength. As discussed above, since damage involves various parameters and are all coupled together, it will be necessary to quantify the threshold loading with each parameter individually specified.

Furthermore, impact loading is a dynamic process; it involves a different loading mechanism than static loading. When the GI internal pressure is increased gradually, as in the case of bursting pressure tests described above, blood in the capillaries tends to be squeezed back into the blood-supplying vessels in the mesentarium. A slow loading with enough time for blood to escape would therefore be less likely to cause contusion damage. Under impact loading, the pressure wave will propagate to everywhere in a relatively short time, blood in the vessels is more likely to be trapped and reach its damage threshold. Based on the same argument, a faster pressure rise perhaps will cause damage at a lower threshold. This could also mean that pressure wave propagation speed might play an important role in defining injury threshold. However, since the content of the abdomen is essentially similar to water, we expect that the wave speed will be quite similar between the two. The speed of propagation, however, could be modified by the total amount of air present in the test chamber due to air injection in the test sections.

### 5.6 REPEATED LOADING

As discussed earlier, repeated impacts could cause material fatigue and result in a lower damage level for the GI tract. Blast repetition could cause the area of contusion injury to spread and induce new contusion sites. When carried to the extreme, material fatigue could lead to gut wall rupture (Figure 12).

One important parameter in repeated impact is the rate of repetition. It is expected that as the interval between shots gets closer and closer, the effect will eventually be similar to that of the sum of two single shots. Though the threshold time spacing would be hard to determine, it is anticipated that if the second impact arrives before there is enough time for the first pressure wave to relax, it could result in a cumulative effect.



## 6. CONCLUDING REMARKS

From the scoping experiment described in this report, the following remarks can be made.

- Evidence suggests that there is strong correlation between the presence of air bubbles and the locations of GI wall contusion.
- The approach adopted in this report is feasible. It offers the advantages of convenience, control and direct visualization capability.
- For a viable preparation, temperature control and submersion in saline during operation are essential. Using the complete GI tract loop is necessary to maintain the blood reserve and preserve the liveliness of the test specimen. Test sections should be tied off from the GI tract loop for preparation and tests; dissected small sections will substantially alter the properties of the GI tract and are not adequate for determining the injury threshold.
- Three types of injury were identified: mucosal bleeding, serosal bleeding, and wall rupture. Mucosal bleeding appeared to take place earlier than serosal bleeding, and wall rupture requires highest blast loading.
- Repeated impact tends to cause material fatigue and lead to earlier injury.
- GI tract injury depends on the following parameters: the amount of air present, internal pressure, vascular pressure, material strength, loading, and number and rate of blasts.



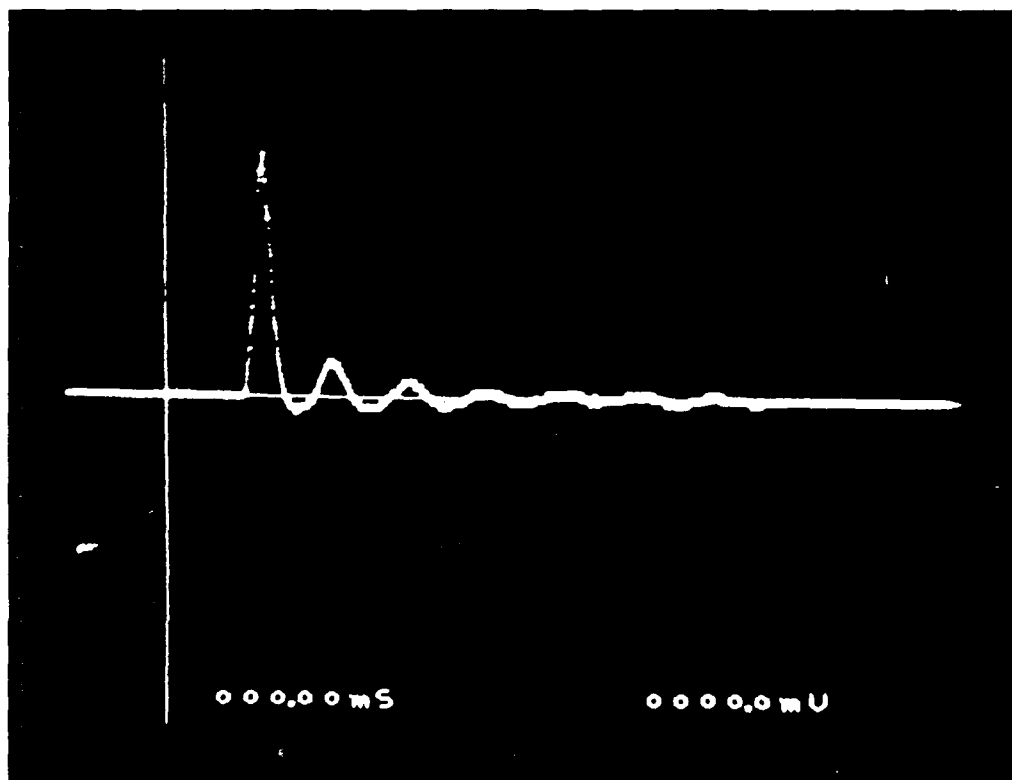

Figure 1. A typical impact signal ( $P_{\max} = 50$  psi, Rise time = 3.8 ms, peak to peak = 8 ms)

All materials E6061-T6 aluminum

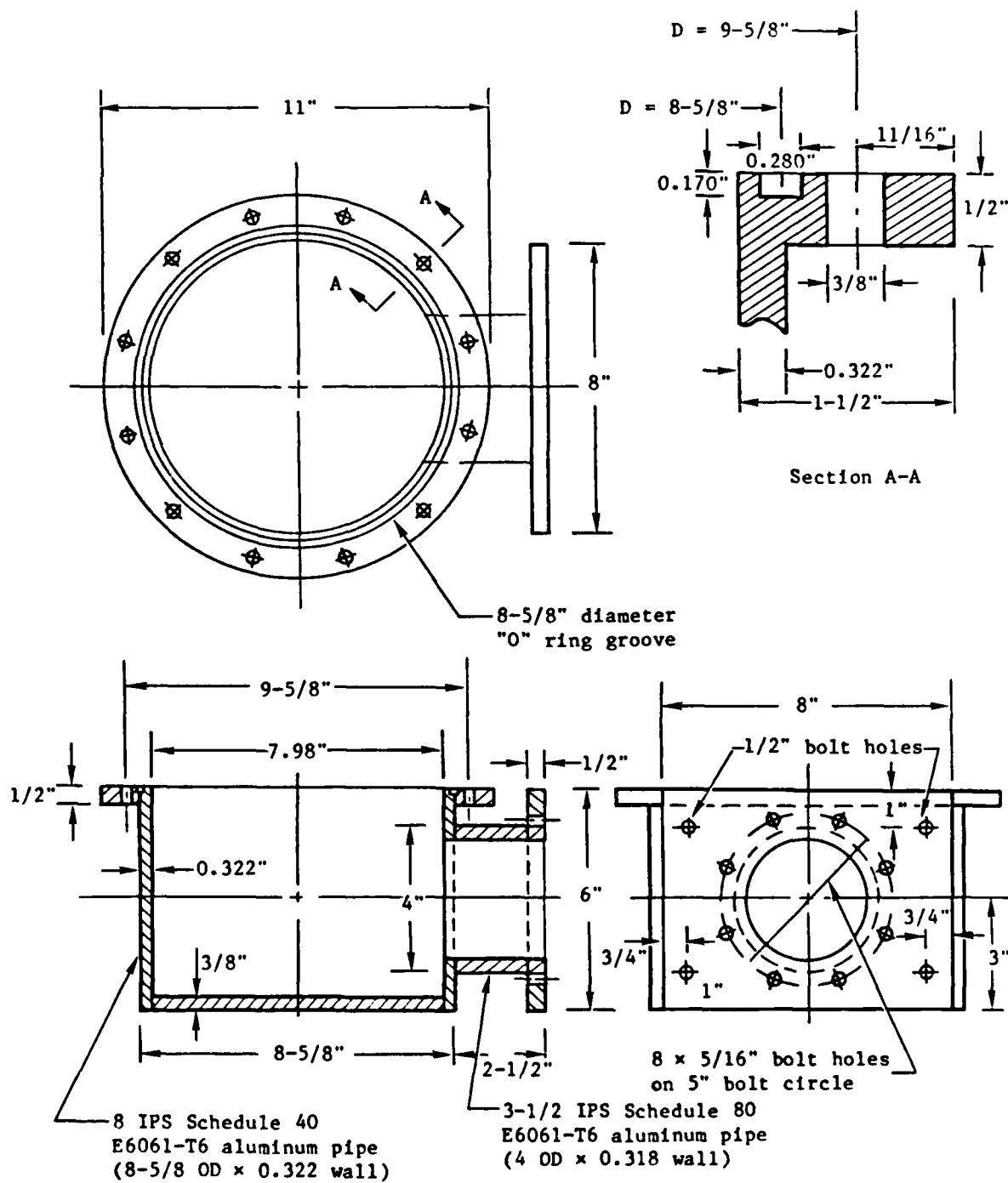

Figure 2. GI tract blast overpressure test chamber

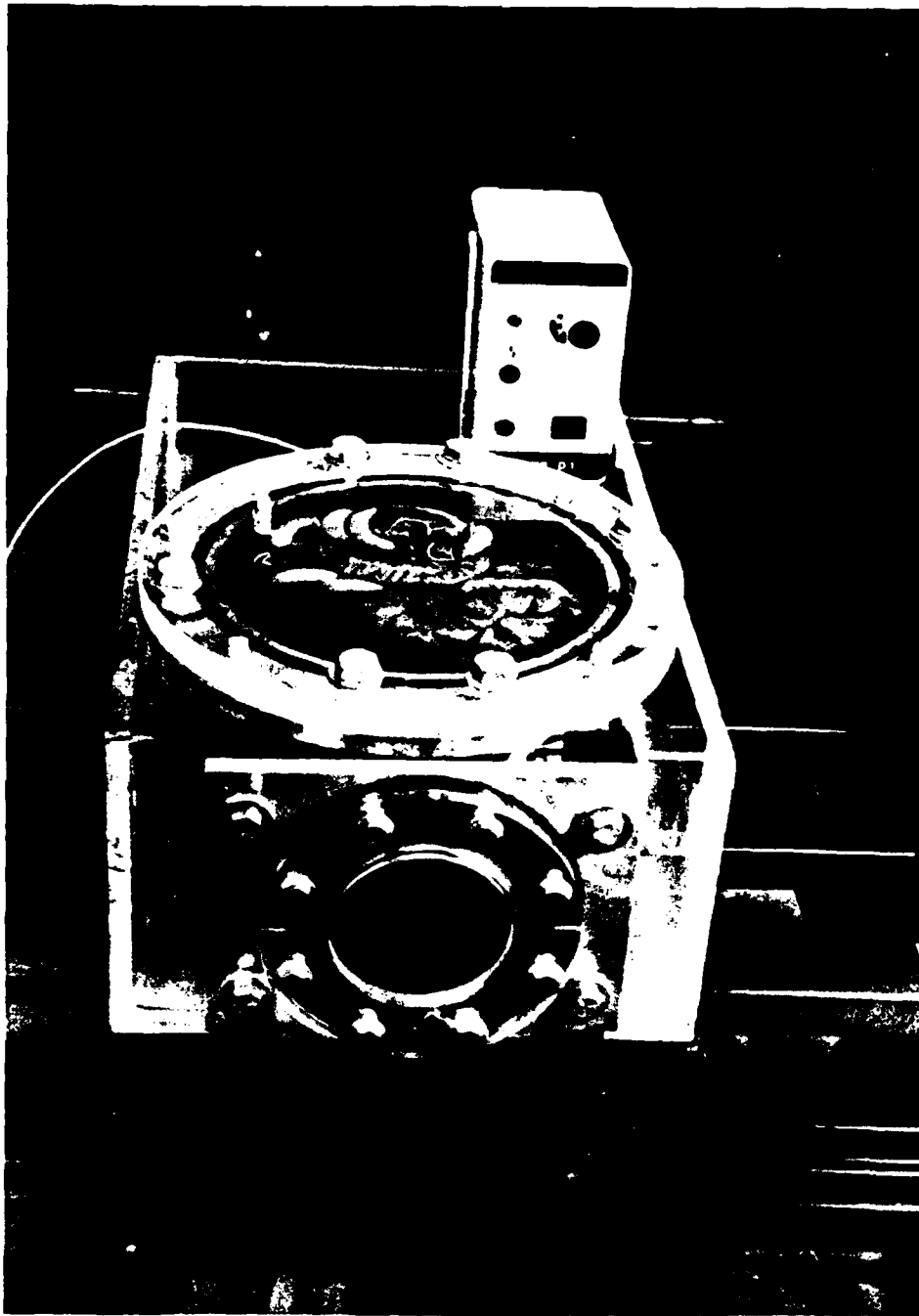
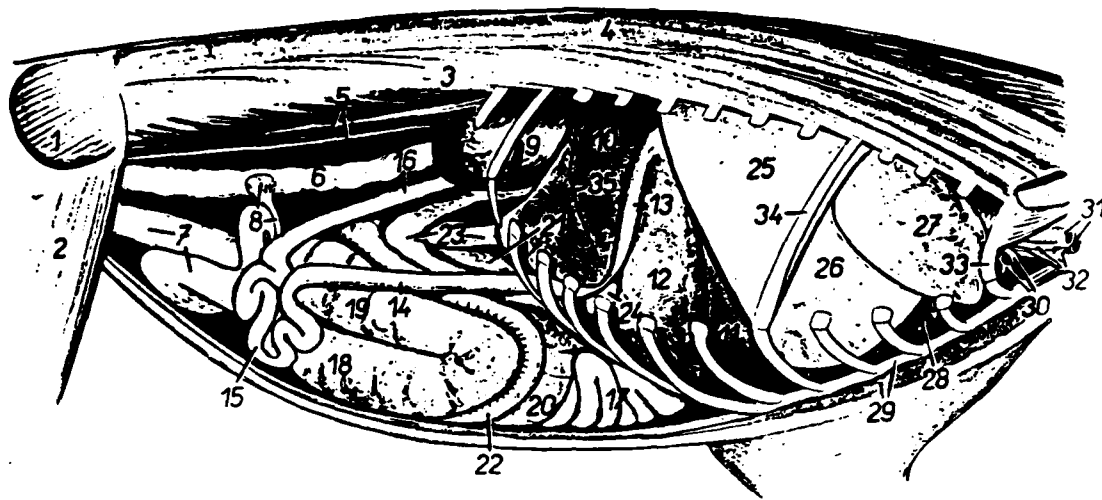

Figure 3. Test chamber mounted in constant temperature bath



(a) Right View

- |  |  |  |
|--|--|--|
| 1 <i>m. gluteus medius</i> - middle gluteal muscle   | 12. <i>ventriculus (gaster)</i> - ventriculus (stomach)  | 24. <i>colon transversum</i> - transverse colon  |
| 2 <i>m. tensor fasciae latae</i> - tensor fasciae latae muscle   | 13. <i>pars cranialis duodeni</i> - cranial part of duodenum                                   | 25. <i>lobus caudalis pulmonis dexteri</i> - caudal lobe of right lung   |
| 3 <i>m. iliocostalis lumborum et iliocostalis thoracis</i> - iliocostalis lumborum et iliocostalis thoracis muscle | 14. <i>pars descendens duodeni</i> - descending part of duodenum                               | 26. <i>lobus medius pulmonis dexteri</i> - middle lobe of right lung   |
| 4 <i>m. longissimus lumborum et longissimus thoracis</i> - longissimus lumborum et longissimus thoracis muscle     | 15. <i>pars transversa (ansa caudalis) duodeni</i> - transverse part (caudal ansa) of duodenum | 27. <i>lobus cranialis pulmonis dexteri</i> - cranial lobe of right lung   |
| 5 <i>m. psoas major, ureter dexter</i> - psoas major muscle, right ureter  | 16. <i>pars ascendens duodeni</i> - ascending part of duodenum                                 | 28. <i>cor</i> - heart   |
| 6. <i>colon descendens</i> - descending colon  | 17. <i>jejunum</i> - jejunum   | 29. <i>sternum, mm. pectorales</i> - sternum, pectoral muscles   |
| 7. <i>uterus dexter</i> - right uterus   | 18 - 21. <i>caecum</i> - cecum   | 30. <i>a. et v. axillares</i> - axillary artery and vein   |
| 8. <i>ovarium, tuba uterina</i> - ovaries, uterine tube  | 18. <i>gyrus primus caeci</i> - first gyrus of cecum   | 31. <i>trachea, oesophagus</i> - trachea, esophagus  |
| 9. <i>ren dexter</i> - right kidney  | 19. <i>gyrus secundus caeci</i> - second gyrus of cecum  | 32. <i>a. caudalis communis, v. jugularis, truncus venosus sympathicus</i> - common caudal artery, jugular vein, vagosympathetic trunk |
| 10. <i>processus caudatus hepatis</i> - caudate process of liver   | 20. <i>gyrus tertius caeci</i> - third gyrus of cecum  | 33. <i>costa I</i> - first rib   |
| 11. <i>lobus dexter hepatis</i> - right lobe of liver  | 21. <i>appendix vermiformis caeci</i> - vermiform appendix of cecum                            | 34. <i>costa V</i> - fifth rib   |
|  | 22. <i>ansa proximalis coli</i> - proximal ansa of colon                                       | 35. <i>linea insertionis diaphragmatis</i> - diaphragmatic line of insertion   |
|  | 23. <i>ansa distalis et ansa centralis coli</i> - distal ansa and central ansa of colon        |  |

Figure 4. Internal organs of a rabbit (from Atlas of Topographical Anatomy of the Domestic Animals, by P. Popesko)

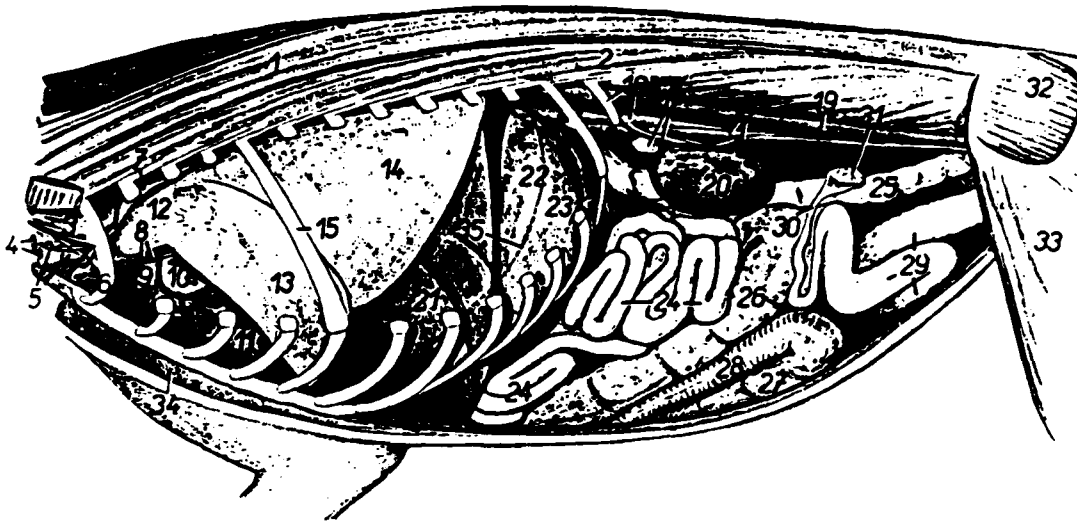

(b) Left View

- |  |  |   |
|--|--|---|
| <p>1 <i>m. longissimus thoracis et longissimus lumborum</i> - longissimus thoracis et longissimus lumborum muscle</p> <p>2 <i>m. interscalaris thoracis et interscalaris lumborum</i> - interscalaris thoracis et interscalaris lumborum muscle</p> <p>3 <i>m. scalenus medius</i> - scalenus medius muscle</p> <p>4 <i>trachea; esophagus</i> - trachea, esophagus</p> <p>5 <i>a. carotis communis; jugularis</i> - common carotid artery, jugular vein</p> <p>6 <i>a. et v. axillaris</i> - axillary artery and vein</p> <p>7 <i>arcus aorticus</i> - aortic arch</p> <p>8 <i>n. phrenicus; v. cava cranialis sinistra</i> - phrenic nerve, left cranial vena cava</p> <p>9 <i>truncus pulmonalis</i> - pulmonary trunk</p> <p>10 <i>auricula atrii sinistra (auricula sinistra)</i> - auricle of left atrium (left auricle)</p> | <p>11 <i>ventriculus sinister caudalis</i> - left ventricle of heart</p> <p>12 <i>pars cranialis lobi cranialis pulmonis sinistri</i> - cranial part of cranial lobe of left lung</p> <p>13 <i>pars caudalis lobi cranialis pulmonis sinistri</i> - caudal part of cranial lobe of left lung</p> <p>14 <i>lobus caudalis pulmonis sinistri</i> - caudal lobe of left lung</p> <p>15 <i>costa V</i> - fifth rib</p> <p>16 <i>costa XIII, aorta abdominalis</i> - thirteenth rib, abdominal aorta</p> <p>17 <i>glandula suprarenalis sinistra, a. renalis sinistra</i> - left suprarenal gland, left renal artery</p> <p>18 <i>v. cava caudalis, venter sinistra</i> - caudal vena cava, left ureter</p> <p>19 <i>m. psoas major</i> - psoas major muscle</p> <p>20 <i>ren sinistra</i> - left kidney</p> <p>21 <i>hepar</i> - liver</p> | <p>22 <i>ventriculus (caeter)</i> - ventriculus (stomach)</p> <p>23 <i>lien</i> - spleen</p> <p>24 <i>pylorum</i> - pylorium</p> <p>25 <i>colon descendens</i> - descending colon</p> <p>26, 27 <i>caecum</i> - caecum</p> <p>26 <i>gyrus tertius caeci</i> - third gyrus of caecum</p> <p>27 <i>gyrus primus caeci</i> - first gyrus of caecum</p> <p>28 <i>colon ascendens (ansa proximalis)</i> - ascending colon (proximal ansa)</p> <p>29 <i>uterus sinister</i> - left uterus</p> <p>30 <i>tubus uterinus</i> - uterine tube</p> <p>31 <i>ovarium</i> - ovary</p> <p>32 <i>m. gluteus medius</i> - middle gluteal muscle</p> <p>33 <i>m. tensor fasciae latae</i> - tensor fasciae latae muscle</p> <p>34 <i>mus. pectorales</i> - pectoral muscles</p> <p>35 <i>linea insertionis diaphragmatis</i> - diagonal line of insertion</p> |
|--|--|---|

Figure 4. (Cont'd)



Figure 5. GI tract of a rabbit

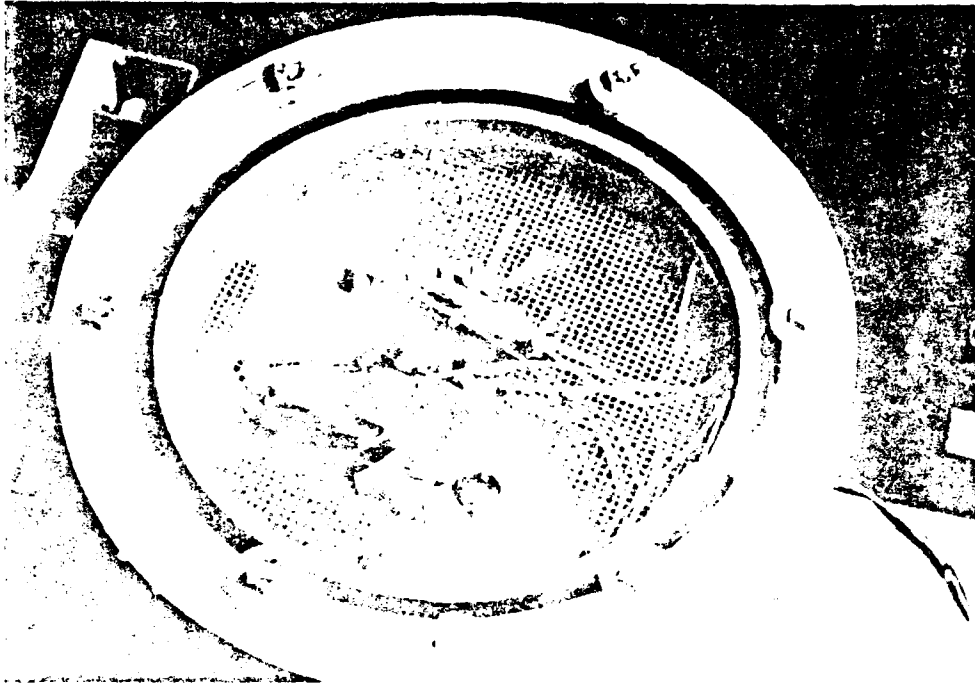

Figure 6. Isolated GI tract test sections (Marks show locations of injected air bubbles.)

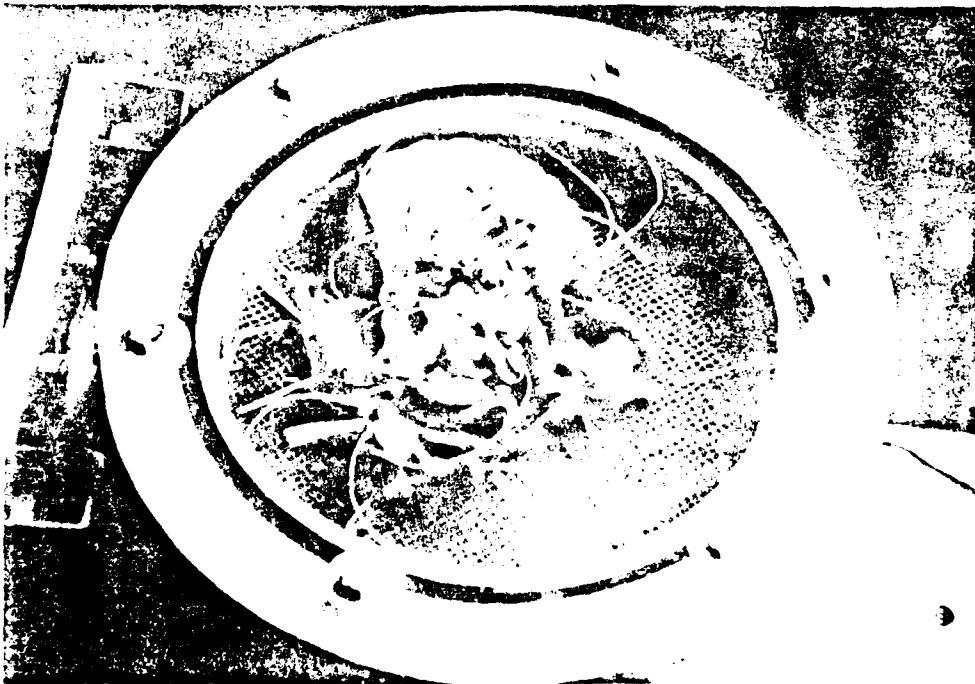

Figure 7. Complete GI tract with tied-off test sections

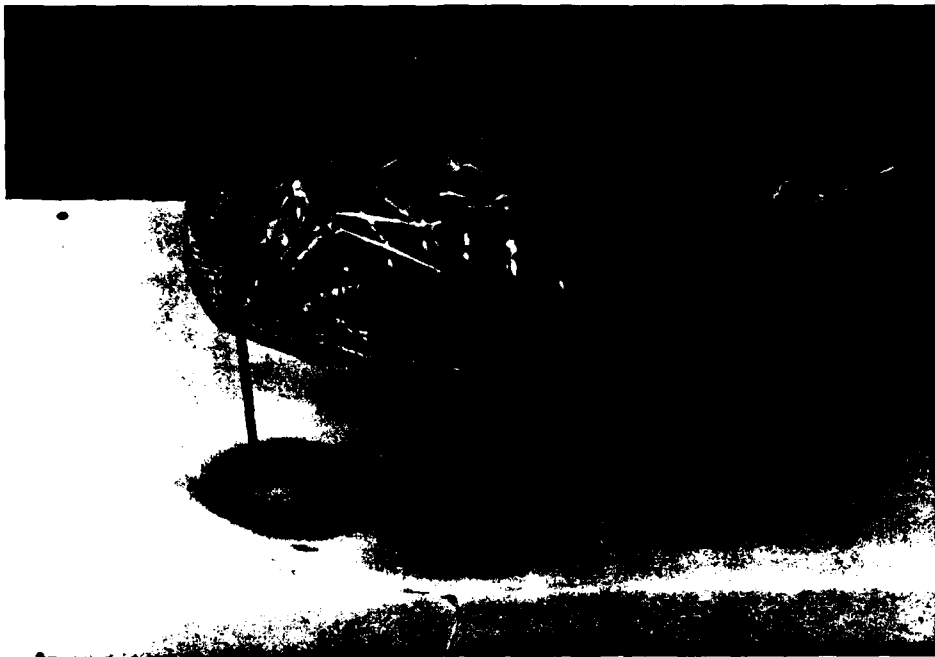

Figure 8. Transfer and support basket



Figure 9. Contusion injury



Figure 10. Contusion injuries and local wall rupture



Figure 11. GI wall rupture injury

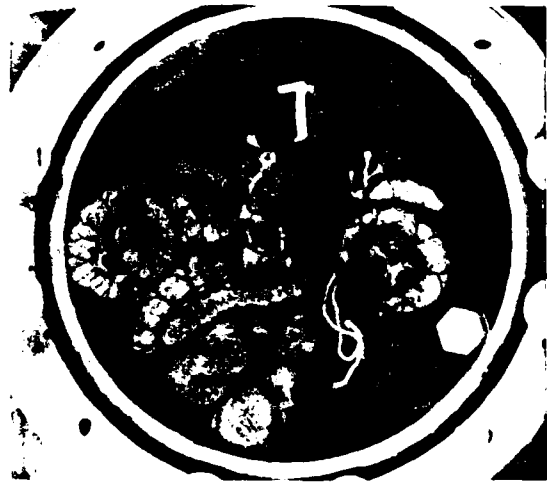
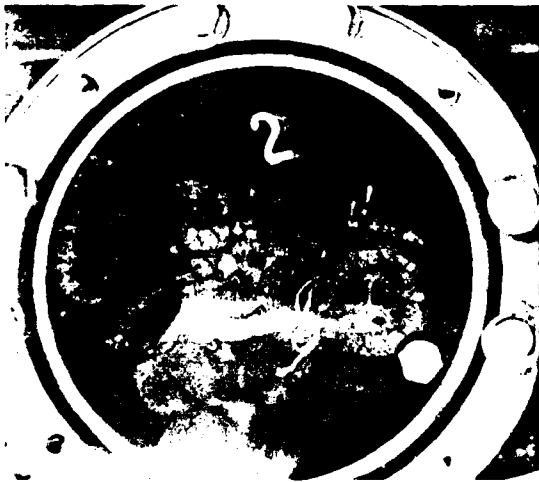
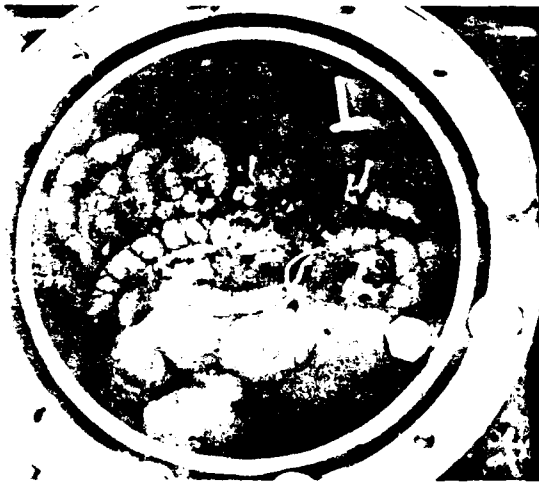
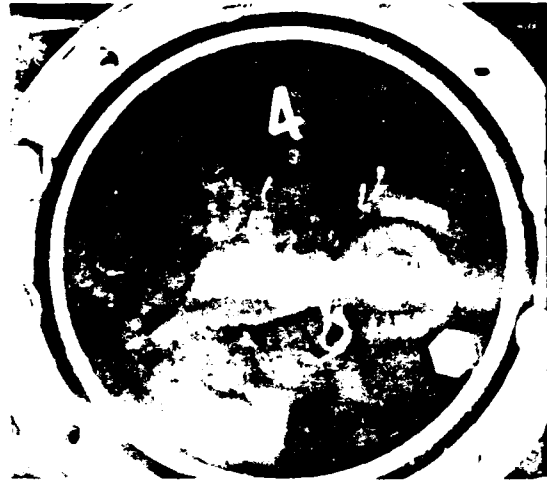

Figure 12. Effect of multiple shots on GI tract injury

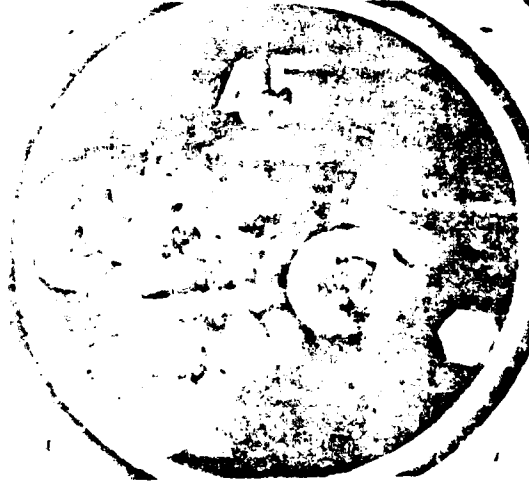

Figure 12. (Cont'd)

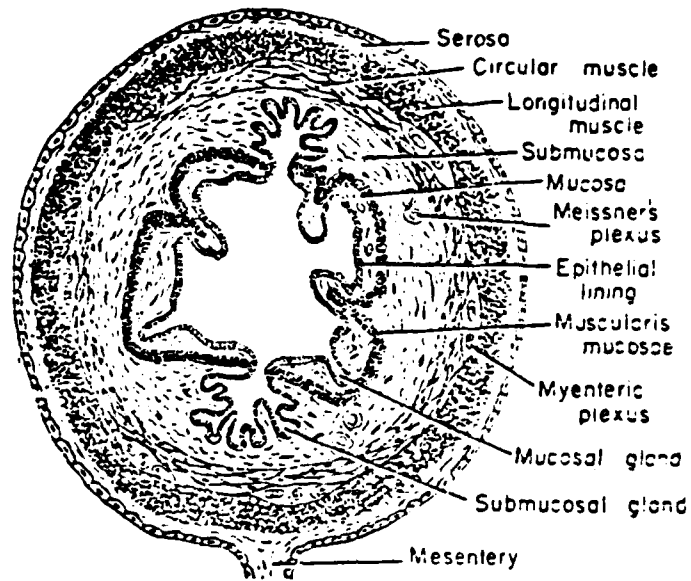

Figure 13. Typical cross-section of the gut (from Text Book of Medical Physiology by A. Guyton)



Figure 14. GI tract bursting pressure test

## DISTRIBUTION LIST

12 copies    Director  
Walter Reed Army Institute of Research  
Walter Reed Army Medical Center  
ATTN: SGRD-UWZ-C  
Washington, DC 20307-5100

4 copies    Commander  
US Army Medical Research and Development Command  
ATTN: SGRD-RMS  
Fort Detrick, Frederick, Maryland 21701-5012

12 copies    Defense Technical Information Center (DTIC)  
ATTN: DTIC-DDAC  
Cameron Station  
Alexandria, VA 22304-6145

1 copy      Dean  
School of Medicine  
Uniformed Services University of the Health Sciences  
4301 Jones Bridge Road  
Bethesda, MD 20814-4799

1 copy      Commandant  
Academy of Health Sciences, US Army  
ATTN: AHS-CDM  
Fort Sam Houston, TX 78234-6100



**END**

**FILMED**

**5-85**

**DTIC**