

AD-A153 632

STRESSES IN A HALF-PLANE CONTAINING EITHER A
PRESSURIZED HOLE OR AN INTERFERENCE-FIT DISC(U)
AERONAUTICAL RESEARCH LABS MELBOURNE (AUSTRALIA)

1/1

UNCLASSIFIED

G S JOST JUL 84 ARL-STRUC-R-409

F/G 20/11

NL

END

FORM 10

DTX

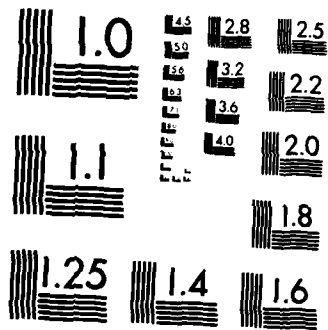

MICROCOPY RESOLUTION TEST CHART
NATIONAL BUREAU OF STANDARDS-1963-A

~~2~~ ①



AD-A153 632

DEPARTMENT OF DEFENCE
DEFENCE SCIENCE AND TECHNOLOGY ORGANISATION
AERONAUTICAL RESEARCH LABORATORIES
MELBOURNE, VICTORIA

STRUCTURES REPORT 409

STRESSES IN A HALF-PLANE CONTAINING
EITHER A PRESSURIZED HOLE OR
AN INTERFERENCE-FIT DISC

THE UNITED STATES NATIONAL
TECHNICAL INFORMATION SERVICE
IS AUTHORISED TO
REPRODUCE AND SELL THIS REPORT

by

G. S. JOST

APPROVED FOR PUBLIC RELEASE

A DTIC
ELECTE
MAY 9 1985
S *D*

B

DTIC FILE COPY

© COMMONWEALTH OF AUSTRALIA 1984

DEPARTMENT OF DEFENCE
DEFENCE SCIENCE AND TECHNOLOGY ORGANISATION
AERONAUTICAL RESEARCH LABORATORIES

STRUCTURES REPORT 409

**STRESSES IN A HALF-PLANE CONTAINING
EITHER A PRESSURIZED HOLE OR
AN INTERFERENCE-FIT DISC**

by
G. S. JOST

DTIC
ELECTE
MAY 9 1985
S B D

SUMMARY

Comparisons have been made of the theoretical stresses in a half-plane containing either a pressurized hole or an interference-fit disc. For a hole more than about three radii from the free edge the differences between the two cases become progressively more insignificant.



© COMMONWEALTH OF AUSTRALIA 1984

POSTAL ADDRESS: Director, Aeronautical Research Laboratories,
Box 4331, P.O., Melbourne, Victoria, 3001, Australia

CONTENTS

Page No.

NOMENCLATURE

1. INTRODUCTION	1
2. STRESSES IN A HALF-PLANE CONTAINING A PRESSURIZED HOLE	1
3. STRESSES IN A HALF-PLANE CONTAINING A BONDED INTERFERENCE-FIT DISC OF THE SAME MATERIAL	3
4. COMPARISON OF THE PREVIOUS CASES	5
5. CONCLUSIONS	6

REFERENCES

FIGURES

DISTRIBUTION

DOCUMENT CONTROL DATA



Acquisition For	
Initial	<input checked="" type="checkbox"/>
Final	<input type="checkbox"/>
Revised	<input type="checkbox"/>
Reproduction	<input type="checkbox"/>
Distribution/	
Availability Codes	
Dist	Special
A-1	

NOMENCLATURE

a	distance from hole centre to free edge
A	$\equiv a + x = 2a + r \cos \theta$
B	$\equiv y = r \sin \theta$
e	distance of bipolar coordinate pole from origin
E	Young's modulus
G	shear modulus $= E/[2(1 + \nu)]$
p	pressure in hole
q	$\equiv 4G\lambda/(\kappa + 1)$
r	radius from hole centre to point under consideration
R	radius of hole
x, y	Cartesian coordinates
α, β	bipolar coordinates
α_1	value of α on hole boundary
θ	angle at hole centre between x axis and point under consideration
κ	$\equiv (3 - \nu)/(1 + \nu)$ for plane stress; $(3 - 4\nu)$ for plain strain
λ	radial interference/ R
ν	Poisson's ratio
π	pi
$\hat{r}r$	radial stress
$\hat{\theta}\theta$	circumferential stress
$\hat{r}\theta$	shear stress

$\hat{x}x$ Cartesian stress, x direction

$\hat{y}y$ Cartesian stress, y direction

\hat{xy} shear stress

$\hat{\alpha}\alpha$ bipolar stress along lines of constant β

$\hat{\beta}\beta$ bipolar stress along lines of constant α

$\hat{\alpha}\beta$ shear stress

The following conversions are useful:

$$\sinh \alpha_1 = \sqrt{(a/R)^2 - 1}$$

$$\cosh \alpha_1 = a/R$$

$$\sin \beta = \sinh \alpha_1 \sin \theta / [\cosh \alpha_1 + \cos \theta]$$

1. INTRODUCTION

In an earlier Report¹ an approximation was developed for the stresses and strains in a half-plane containing an interference-fit fastener based on the exact theory for a half-plane containing a pressurized hole.² Predictions from the approximate theory were compared with experimental data and found to be good. Although they were shown to improve as the hole became more remote from the free edge, the stage at which the approximation became invalid could not be established from that study.

Since then, the exact theory³ for a bonded interference-fit disc in a half-plane of the same material has been formulated explicitly.⁴ The two solutions, each exact for its own boundary conditions, can now be compared directly to establish the features of similarity or otherwise.

2. STRESSES IN A HALF-PLANE CONTAINING A PRESSURIZED HOLE

The solution to this problem, Fig. 1, was provided by Jeffery² in terms of bipolar parameters as follows:

$$\hat{\alpha}\alpha/p = -\{(\cosh \alpha - \cos \beta)2 \cosh \alpha_1 \sinh \alpha + 2 \cosh (2\alpha - \alpha_1) \sinh \alpha \cos \beta - \sinh \alpha_1 - \sinh (2\alpha - \alpha_1)\} / 2 \sinh^3 \alpha_1 \quad (1)$$

$$\hat{\beta}\beta/p = \{(\cosh \alpha - \cos \beta)[2 \cosh \alpha_1 \sinh \alpha + 4 \sinh (2\alpha - \alpha_1) \cos \beta] - 2 \cosh (2\alpha - \alpha_1) \sinh \alpha \cos \beta + \sinh \alpha_1 + \sinh (2\alpha - \alpha_1)\} / 2 \sinh^3 \alpha_1 \quad (2)$$

$$\hat{\alpha}\beta/p = -(\cosh \alpha - \cos \beta)[\cosh \alpha_1 - \cosh (2\alpha - \alpha_1)] \sin \beta / \sinh^3 \alpha_1 \quad (3)$$

Along the circular boundary and the axis of symmetry *only* the following relations hold between bipolar and polar stresses:

$$\hat{r}\alpha \equiv \hat{r}r, \quad \hat{\theta}\beta \equiv \hat{\theta}\theta, \quad \hat{\alpha}\beta \equiv \hat{r}\theta.$$

Along the free edge *only*

$$\hat{\alpha}\alpha \equiv \hat{x}x, \quad \hat{\beta}\beta \equiv \hat{y}y, \quad \hat{\alpha}\beta \equiv \hat{x}y.$$

At the origin *only*

$$\hat{\alpha}\alpha \equiv \hat{x}x \equiv \hat{r}r, \quad \hat{\beta}\beta \equiv \hat{y}y \equiv \hat{\theta}\theta, \quad \hat{\alpha}\beta \equiv \hat{x}y \equiv \hat{r}\theta.$$

To facilitate the comparisons to be made in Section 4, the stresses will be expressed only in polar and Cartesian coordinates.

The above expressions simplify markedly in particular cases:

Around the hole $\alpha = \alpha_1$ and (1), (2) and (3) become

$$\widehat{\alpha\alpha}/p = \widehat{rr}/p = -1 \quad (4)$$

$$\widehat{\beta\beta}/p = \widehat{\theta\theta}/p = 1 + 2 \sin^2 \beta / \sinh^2 \alpha_1 \quad (5)$$

$$\widehat{\alpha\beta}/p = \widehat{r\theta}/p = 0 \quad (6)$$

Equations (4) and (6) are simply a reflection of the boundary conditions for a pressurized hole, and (5) shows that the circumferential stress is a function of the parametric angle β which varies from 0 to $\pm\pi$ around the hole, Fig. 1. In terms of plate geometry and central angle θ (see Fig. 2) (5) becomes, using the relationships listed in the Nomenclature

$$\widehat{\theta\theta}/p = 1 + 2 \sin^2 \theta / [(a/R) + \cos \theta]^2. \quad (7)$$

This reaches a maximum when

$$\theta = \arccos[-(a/R)^{-1}] \quad (8)$$

at which point

$$\widehat{\theta\theta}/p = \frac{(a/R)^2 + 1}{(a/R)^2 - 1}. \quad (9)$$

Jeffery showed that θ above corresponds to the tangent point at the hole formed with a line drawn from the origin. At the points remote from and close to the origin, $\theta = 0$ and $\theta = \pi$, and $\widehat{\theta\theta}/p$ reaches minimum values of unity.

Along the free edge $\alpha = 0$ and (1), (2) and (3) become

$$\widehat{\alpha\alpha}/p = \widehat{xx}/p = 0 \quad (10)$$

$$\widehat{\beta\beta}/p = \widehat{yy}/p = -2(1 - \cos \beta) \cos \beta / \sinh^2 \alpha_1 \quad (11)$$

$$\widehat{\alpha\beta}/p = \widehat{xy}/p = 0 \quad (12)$$

As before, (11) may be expressed in terms of the parameters of Fig. 2 but the result is unhelpful.

\widehat{yy}/p is a maximum at the origin when it becomes

$$\widehat{yy}/p = \frac{4}{\sinh^2 \alpha_1} = \frac{4}{(a/R)^2 - 1}. \quad (13)$$

For increasing y it decreases in magnitude, becoming negative beyond the point

$$y/R = \sqrt{(a/R)^2 - 1}. \quad (14)$$

The variations in \hat{r}_r/p and $\hat{\theta}\theta/p$ around the hole and along the axis of symmetry for several a/R values are shown in Fig. 3, where the location of the hole is fixed and the free edge is sited progressively further to the left with increase in a/R . Circumferential stresses are everywhere positive, radial stresses being everywhere negative. All stresses asymptote quickly towards the infinite plate solutions with increase in a/R . Figure 4 shows the variation of key parameters with a/R . For a/R less than $\sqrt{3}$, the maximum stress occurs at the free edge at the origin: beyond $a/R = \sqrt{3}$ it occurs at the hole. The angular position of the maximum stress at the hole changes continuously from $\theta = \pi$ at $a/R = 1$ towards its $\pi/2$ asymptote as a/R becomes large.

3. STRESSES IN A HALF-PLANE CONTAINING A BONDED INTERFERENCE-FIT DISC OF THE SAME MATERIAL

Richardson³ provided the stress functions for the solution of this problem but did not enunciate the stresses explicitly. They are,⁴ using the notation of Fig. 2 and the definitions listed in the nomenclature

$$\begin{pmatrix} \hat{r}_r/q \\ \hat{\theta}\theta/q \end{pmatrix} = \mp \frac{R^2}{r^2} + 2R^2 \frac{A^2 - B^2}{(A^2 + B^2)^2} \pm \frac{LR^2}{(A^2 + B^2)^3} \quad (15)$$

$$\hat{r}\theta/q = \frac{MR^2}{(A^2 + B^2)^3} \quad (16)$$

In Cartesian coordinates these become

$$\begin{pmatrix} \hat{x}x/q \\ \hat{y}y/q \end{pmatrix} = 2R^2 \frac{A^2 - B^2}{(A^2 + B^2)^2} \mp NR^2 \quad (17)$$

and

$$\hat{x}y/q = - \frac{2R^2B(A-2a)}{[(A-2a)^2 + B^2]^2} + \frac{2R^2B[A(5A^2 - 3B^2) - 2a(3A^2 - B^2)]}{(A^2 + B^2)^3} \quad (18)$$

where

$$\begin{pmatrix} L \\ M \end{pmatrix} = \left\{ 2[4AB(A^2 - B^2) - aB(3A^2 - B^2)] \begin{pmatrix} \sin 2\theta \\ \cos 2\theta \end{pmatrix} + rB(3A^2 - B^2) \begin{pmatrix} \sin 3\theta \\ \cos 3\theta \end{pmatrix} \right. \\ \left. \pm 2[A^4 - 6A^2B^2 + B^4 - aA(A^2 - 3B^2)] \begin{pmatrix} \cos 2\theta \\ \sin 2\theta \end{pmatrix} \pm rA(A^2 - 3B^2) \begin{pmatrix} \cos 3\theta \\ \sin 3\theta \end{pmatrix} \right\}$$

and

$$N = \left\{ \frac{(A-2a)^2 - B^2}{[(A-2a)^2 + B^2]^2} - \frac{3A^4 - 12A^2B^2 + B^4 - 4aA(A^2 - 3B^2)}{(A^2 + B^2)^3} \right\}$$

As before some useful simplification in expression occurs for stresses at particular points. It is appropriate to use the polar expressions (15) and (16) for stresses around the hole and (17) and (18) for stresses along the free edge.

Around the hole $r = R$, but only inconsequential simplifications occur from this substitution. It is seen however that all three stresses vary around the hole. A derived expression for the maximum circumferential stress is impractical, as is one for the angular position at which it occurs: recourse must therefore be made to numerical solutions. Expressions for the stresses at $\theta = 0$ (remote from free edge) and $\theta = \pi$ (close to free edge) are, however, tractable:

$$\left(\widehat{r\dot{r}}/q\right)_0^\pi = -4 \frac{2(a/R)^3 \mp 3(a/R)^2 \pm 1}{(2a/R \mp 1)^3} \quad (19)$$

$$\left(\widehat{\theta\dot{\theta}}/q\right)_0^\pi = 4 \frac{2(a/R)^3 \mp 3(a/R)^2 + 2(a/R)}{(2a/R \mp 1)^3} \quad (20)$$

and

$$\left(\widehat{r\dot{\theta}}/q\right)_0^\pi = 0. \quad (21)$$

Along the free edge $x = 0$ and (17) and (18) become

$$\widehat{x\dot{x}}/q = 0, \quad (22)$$

$$\widehat{y\dot{y}}/q = 4 \frac{(a/R)^2 - (y/R)^2}{[(a/R)^2 + (y/R)^2]^2} \quad (23)$$

and

$$\widehat{x\dot{y}}/q = 0. \quad (24)$$

Equation (23) has its maximum value at the origin, where

$$\widehat{y\dot{y}}/q = \frac{4}{(a/R)^2}. \quad (25)$$

It becomes zero when

$$y/R = \pm a/R. \quad (26)$$

The variations in stress around the hole and along the axis of symmetry are shown in Fig. 5. The behaviour of the circumferential and tangential stresses each bear strong qualitative resemblances to those for the pressurized hole: radial and shear stresses are, however, fundamentally different. Figure 6 shows that the a/R value at which the location of maximum stress moves from the free edge to the hole is 1.767. The maximum stress at the hole remains at the point $\theta = \pi$ for a/R up to 1.724 after which its location at the hole moves very rapidly towards the $\pi/2$ asymptote as a/r becomes large.

4. COMPARISON OF THE PREVIOUS CASES

In Section 2 stresses have been non-dimensionalized by the divisor p : in Section 3 the divisor was q . Before a direct comparison between the results from the two Sections can be made, the relationship between p and q must be established. This is done on the basis of a common interference for the two cases.

In Reference 1, in which the *average* interference around the hole was used to establish p , the following equations were found:

For plane stress:

$$p = \frac{\lambda E}{2} \tanh \alpha_1$$

For plane strain:

$$p = \frac{\lambda E}{2(1-\nu^2)} \tanh \alpha_1$$

These expressions relate p to the non-dimensional interference λ , plate geometry (α_1) and the elastic parameters of plate (E, ν).

From Reference 3, the non-dimensionalizing parameter q has the following values:

For plane stress:

$$q = \frac{\lambda E}{2}$$

For plane strain:

$$q = \frac{\lambda E}{2(1-\nu^2)}$$

Thus, for both plane stress and plane strain p and q are related as follows:

$$p = q \tanh \alpha_1 \tag{27}$$

The correction (27) has been applied to equations (1), (2) and (3) to produce Figs 7 and 8. These may now be compared directly with Figs 5 and 6.

It is clear that significant differences develop as the hole nears the free edge. Radial and shear stresses begin to vary substantially around the hole for the interference-fit case, whereas they remain constant for the pressurized hole. However, except for extreme closeness of hole and edge, the magnitude of the shear stress remains relatively small. By contrast, the circumferential stresses for interference-fit cases do not exhibit the increasingly extreme fluctuations which develop for the pressurized hole, Fig. 9. For $a/R = 1$, the circumferential stress for this latter case becomes infinite at the point where hole and edge meet.

Along the free edge the behaviours of the two cases are quantitatively similar, the pressurized hole case again exhibiting greater fluctuation. The edge distance ratio beyond which the location of maximum circumferential stress shifts from the free edge to the hole is remarkably similar for both cases: $a/R = \sqrt{3} = 1.732$ for the pressurized hole as against 1.767 for the interference-fit case. The locations of the maximum circumferential stress at the hole each begin at the point closest to the free edge for $a/R = 1$, and both asymptote towards $\theta = \pi/2$ for large a/R . There are, however, significant differences at intermediate values of a/R , Fig. 10.

As a/R increases, Figs 5 to 10 show that all differences between the two cases steadily diminish. This can also be seen directly from the relevant formulae. Consider first the pressurized hole: with increasing a/R , $\sinh \alpha_1 \rightarrow a/R$. Since $\cosh \alpha_1 = a/R$, $\tanh \alpha_1 \rightarrow 1$ and thus $p \rightarrow q$. The stresses around the hole, e.g. (4), (5) and (6), therefore become

$$\widehat{r}r/q \rightarrow \widehat{r}r/p = -1,$$

$$\widehat{\theta}\theta/q \rightarrow \widehat{\theta}\theta/p \rightarrow 1$$

and

$$\widehat{r}\theta/q \rightarrow \widehat{r}\theta/p = 0.$$

Similarly the stresses along the free edge, e.g. (10), (11) and (12) become

$$\widehat{x}x/q \rightarrow \widehat{x}x/p = 0,$$

$$\widehat{y}y/q \rightarrow \widehat{y}y/p \rightarrow 0$$

and

$$\widehat{x}y/q \rightarrow \widehat{x}y/p = 0.$$

Checks on the corresponding equations (19), (20) and (21), and (22), (23) and (24) for the interference-fit case show that they also tend to the above limits as a/R becomes large.

In a general sense, the stage below which the stresses for the two cases begin to differ significantly occurs for a/R less than about three. For larger a/R the theories become, for practical purposes, interchangeable; they must then also become valid for the frictionless interference-fit disc case.

It would now appear that experimental data from a plate containing an interference-fit fastener previously found to be well predicted by the pressurized hole theory¹ was a fortunate outcome in that the a/R ratio there was a marginal 2.93.

5. CONCLUSIONS

Comparisons have been made of the stresses arising from a pressurized hole in a half-plane with those of one containing an interference-fit disc of the same material. Although substantial differences exist between the two cases when the hole is close to the free edge, they diminish very rapidly as the hole becomes more remote: for a hole centre more than about three radii from the edge the differences become progressively more insignificant.

REFERENCES

1. Jost, G. S., and Carey, R. P. Strains in an elastic plate containing an interference-fit bolt near a free edge. *Dept. Defence, Aeronaut. Res. Labs. Structures Report 400*, March 1984.
2. Jeffery, G. B. Plane stress and plane strain in bipolar coordinates. *Phil. Trans. Roy. Soc. Series A*, v. 221, 1921, pp. 265-293.
3. Richardson, M. K. Interference stresses in a half plane containing an elastic disk of the same material. *J. Appl. Mech.*, v. 36, March 1969, pp. 128-130.
4. Jost, G. S., and Carey, R. P. Elastic response of a half-plane to a bonded interference-fit disc of the same material. *Dept. Defence, Aeronaut. Res. Labs. Structures Report 406*, July 1984.

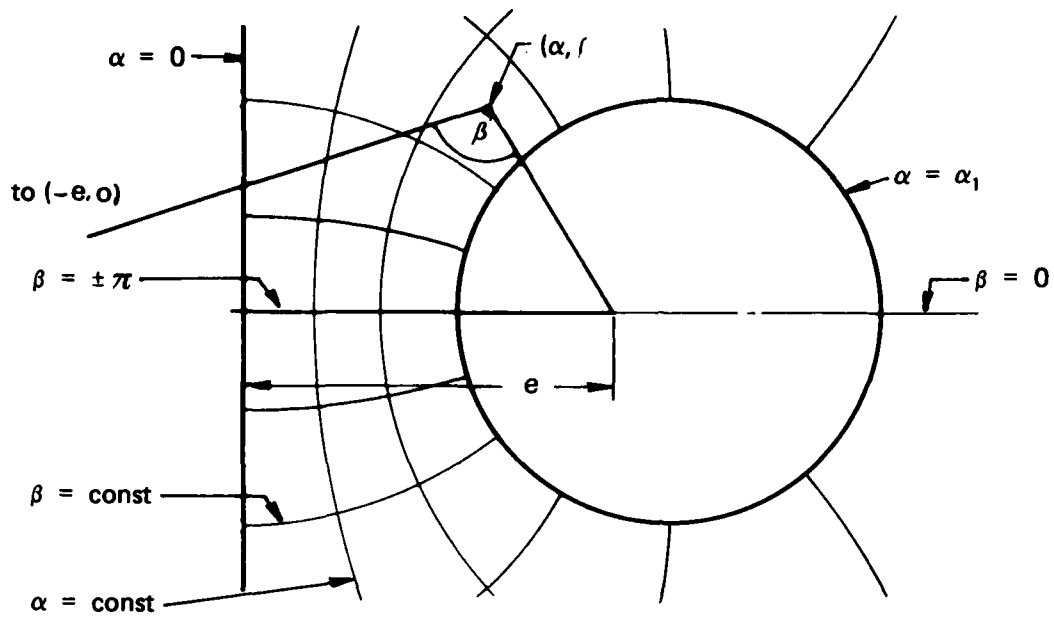

FIG. 1 BIPOLAR COORDINATE SYSTEM

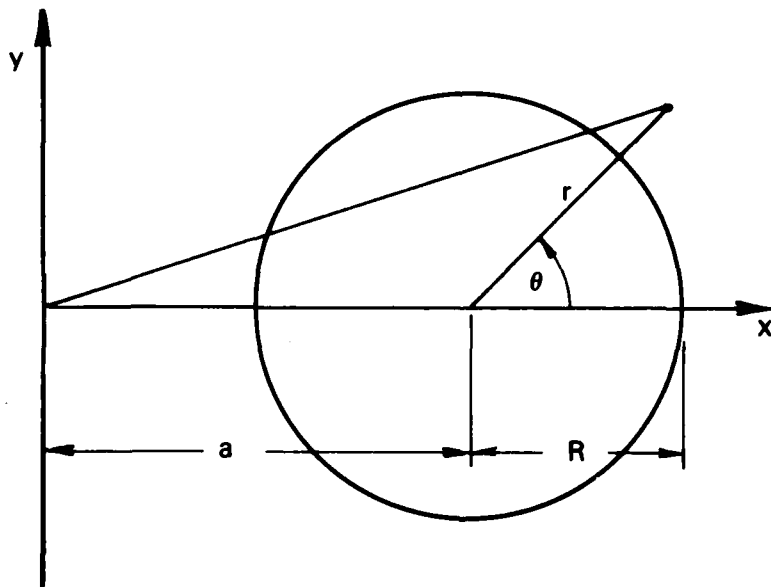

FIG. 2 CARTESIAN AND POLAR COORDINATE SYSTEM

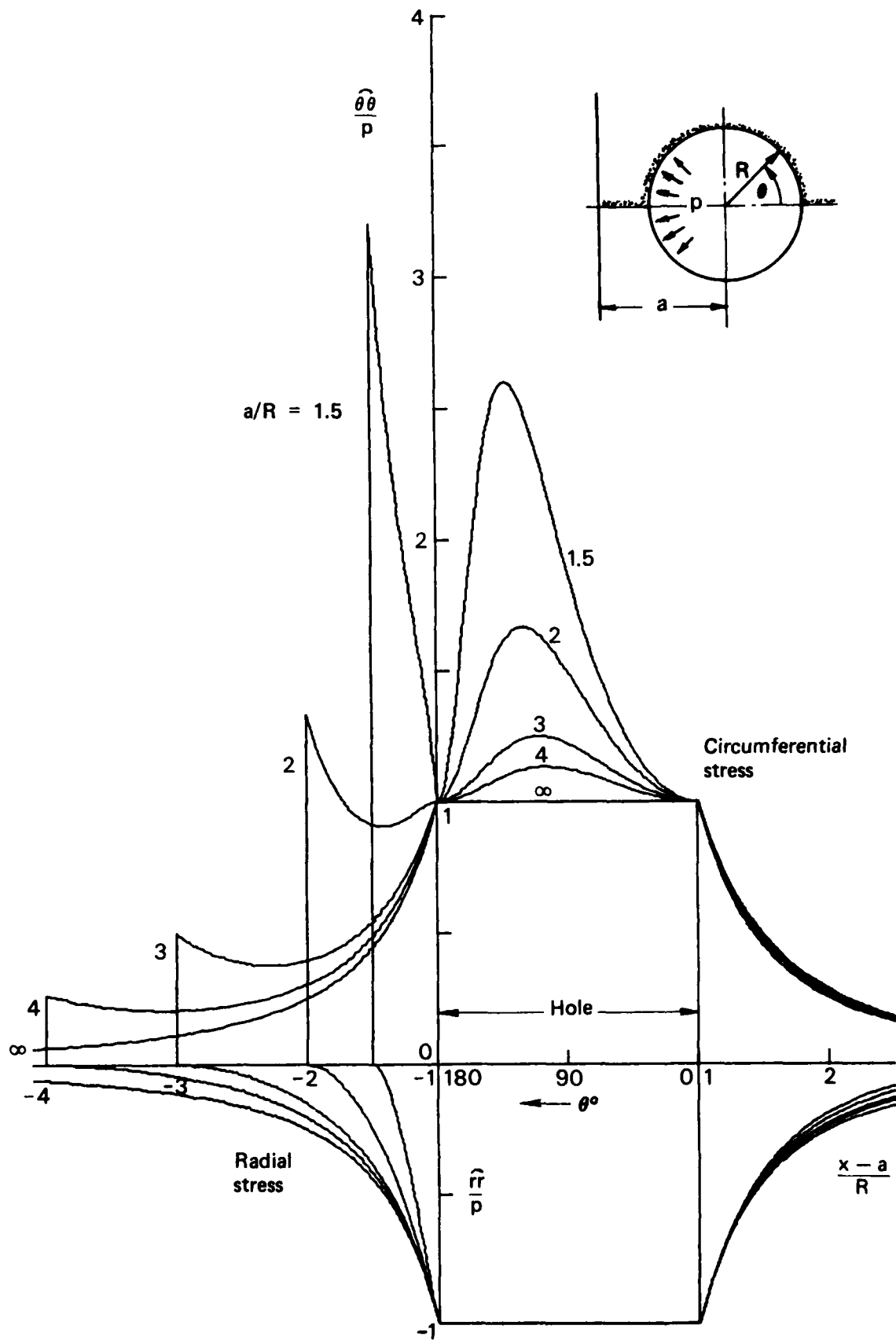

FIG. 3 STRESSES AROUND HOLE AND ALONG AXIS OF SYMMETRY
 - PRESSURIZED HOLE

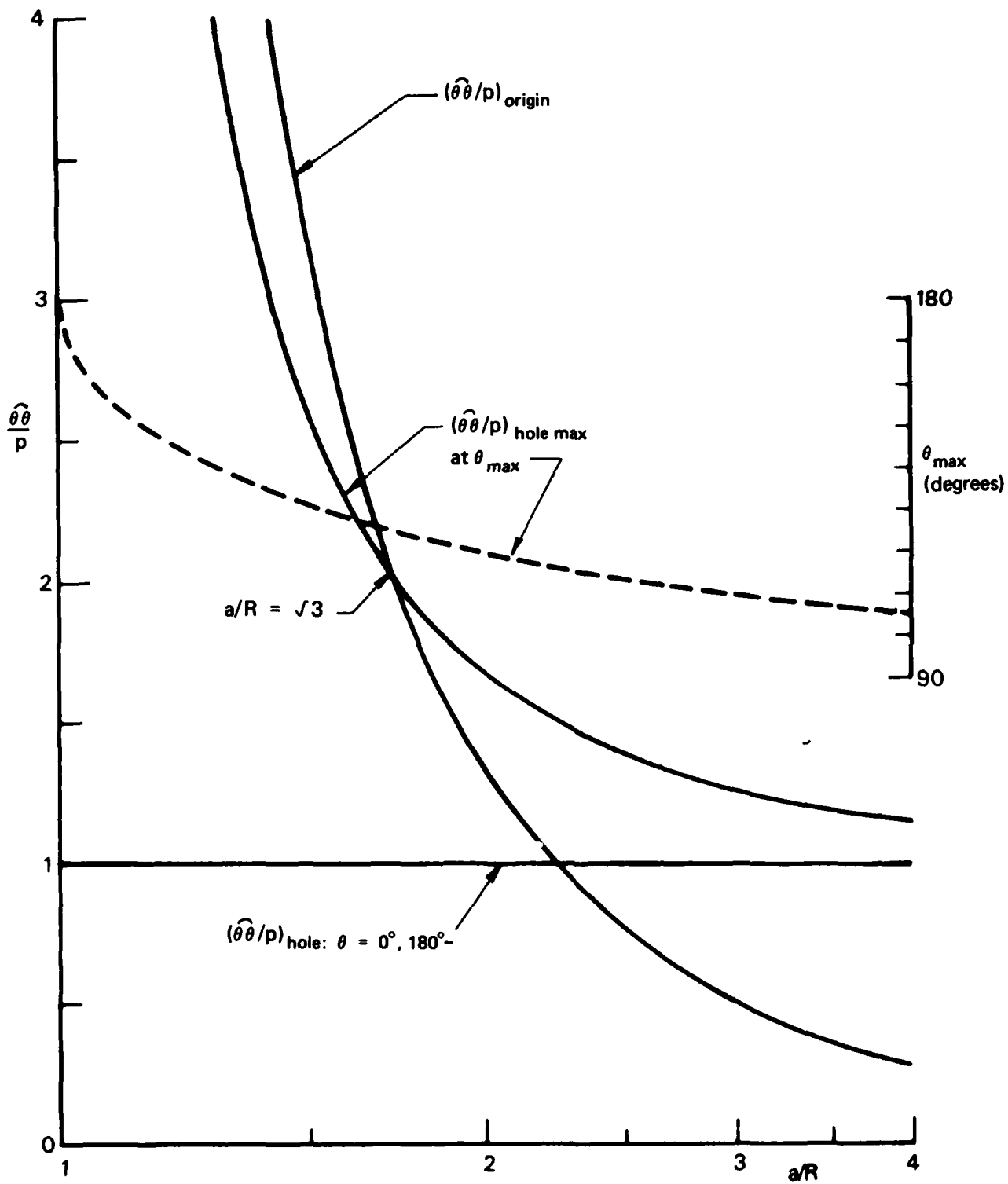

FIG. 4 CIRCUMFERENTIAL AND TANGENTIAL STRESSES AT HOLE AND ORIGIN - PRESSURIZED HOLE

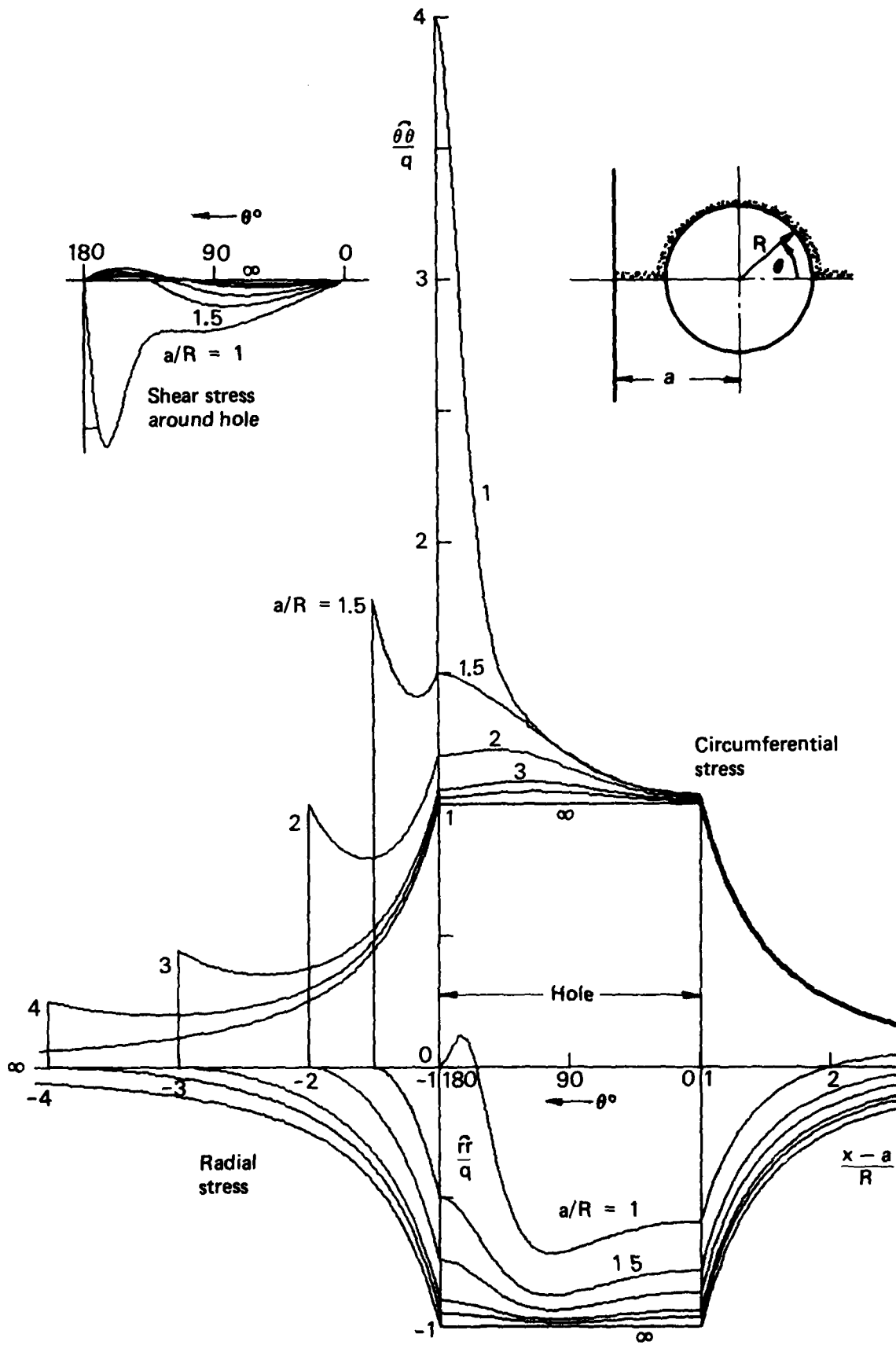

FIG. 5 STRESSES AROUND HOLE AND ALONG AXIS OF SYMMETRY - INTERFERENCE FIT DISC

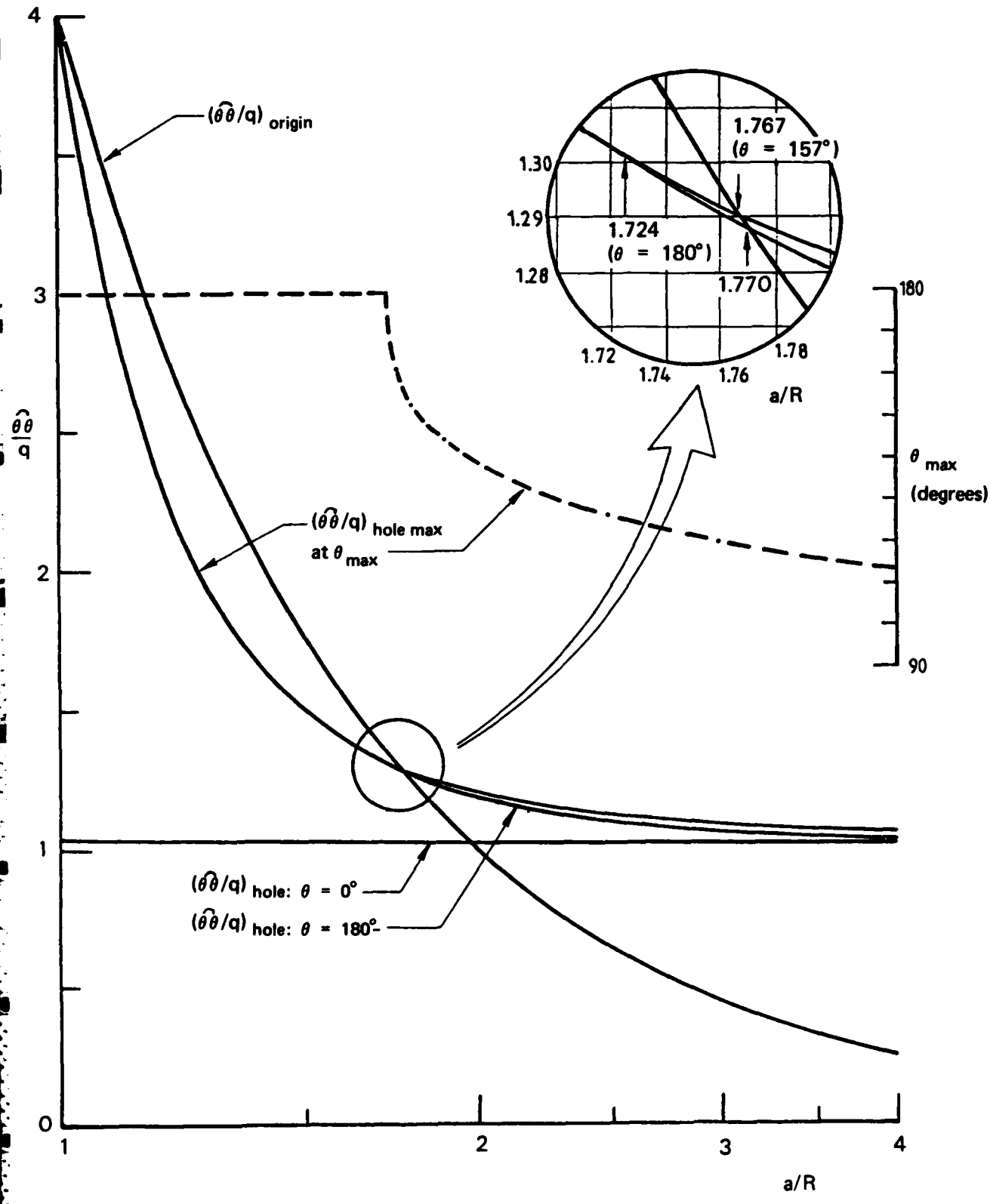

FIG. 6 CIRCUMFERENTIAL AND TANGENTIAL STRESSES AT HOLE AND ORIGIN -- INTERFERENCE-FIT DISC

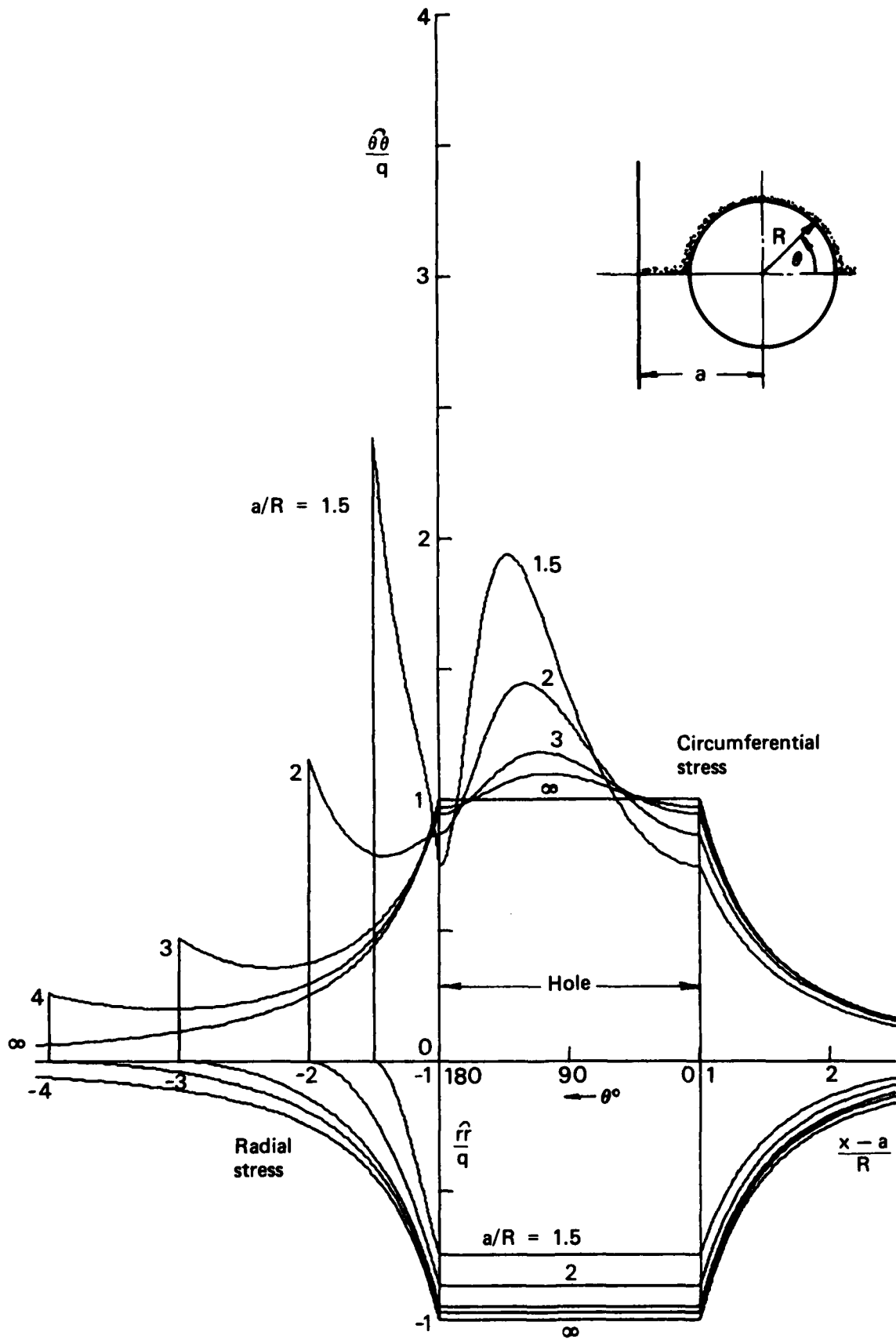

FIG. 7 STRESSES AROUND HOLE AND ALONG AXIS OF SYMMETRY -- PRESSURIZED HOLE (NORMALISED WITH RESPECT TO q)

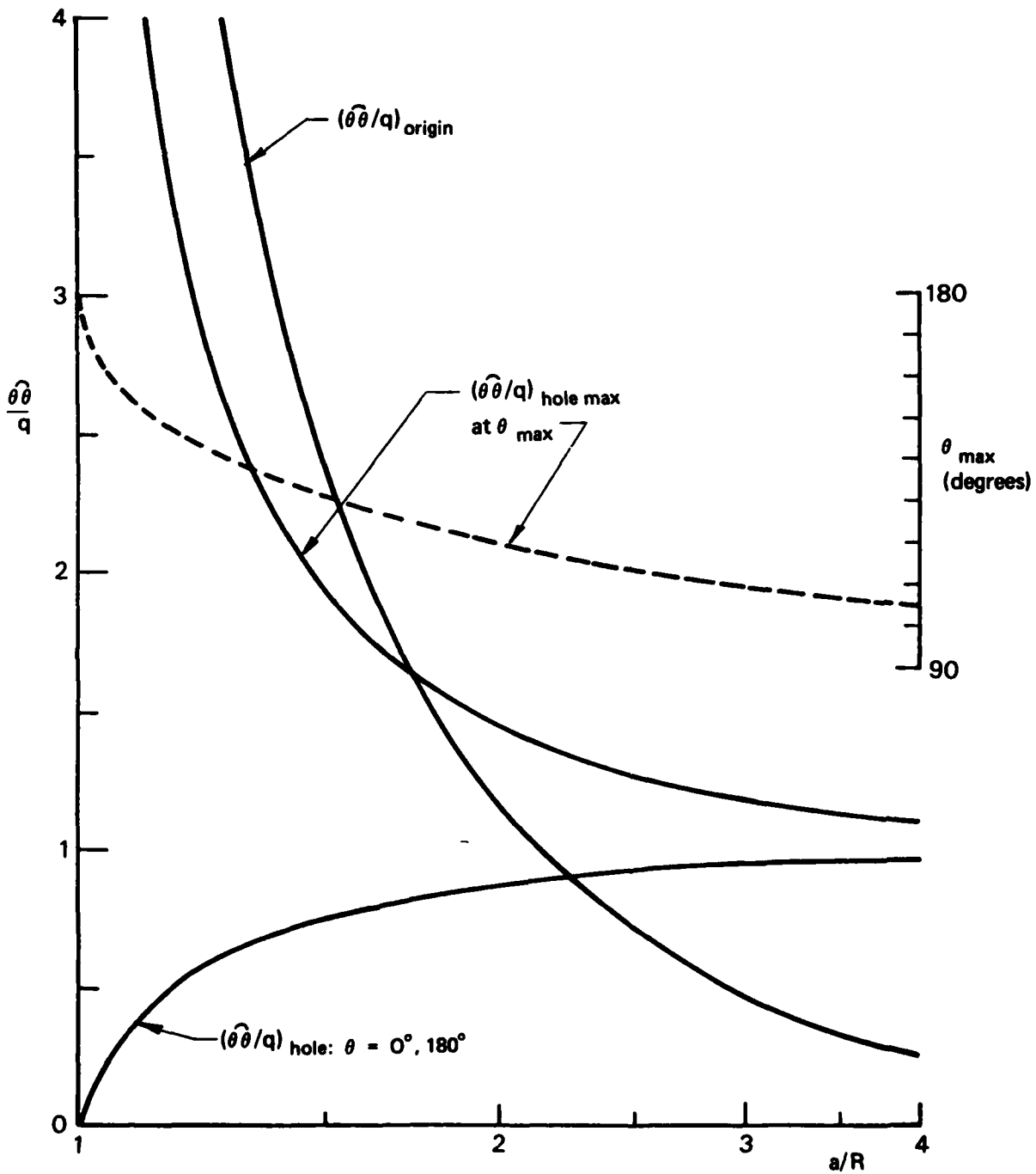

FIG. 8 CIRCUMFERENTIAL AND TANGENTIAL STRESSES AT HOLE AND ORIGIN -- PRESSURIZED HOLE (NORMALISED WITH RESPECT TO q)

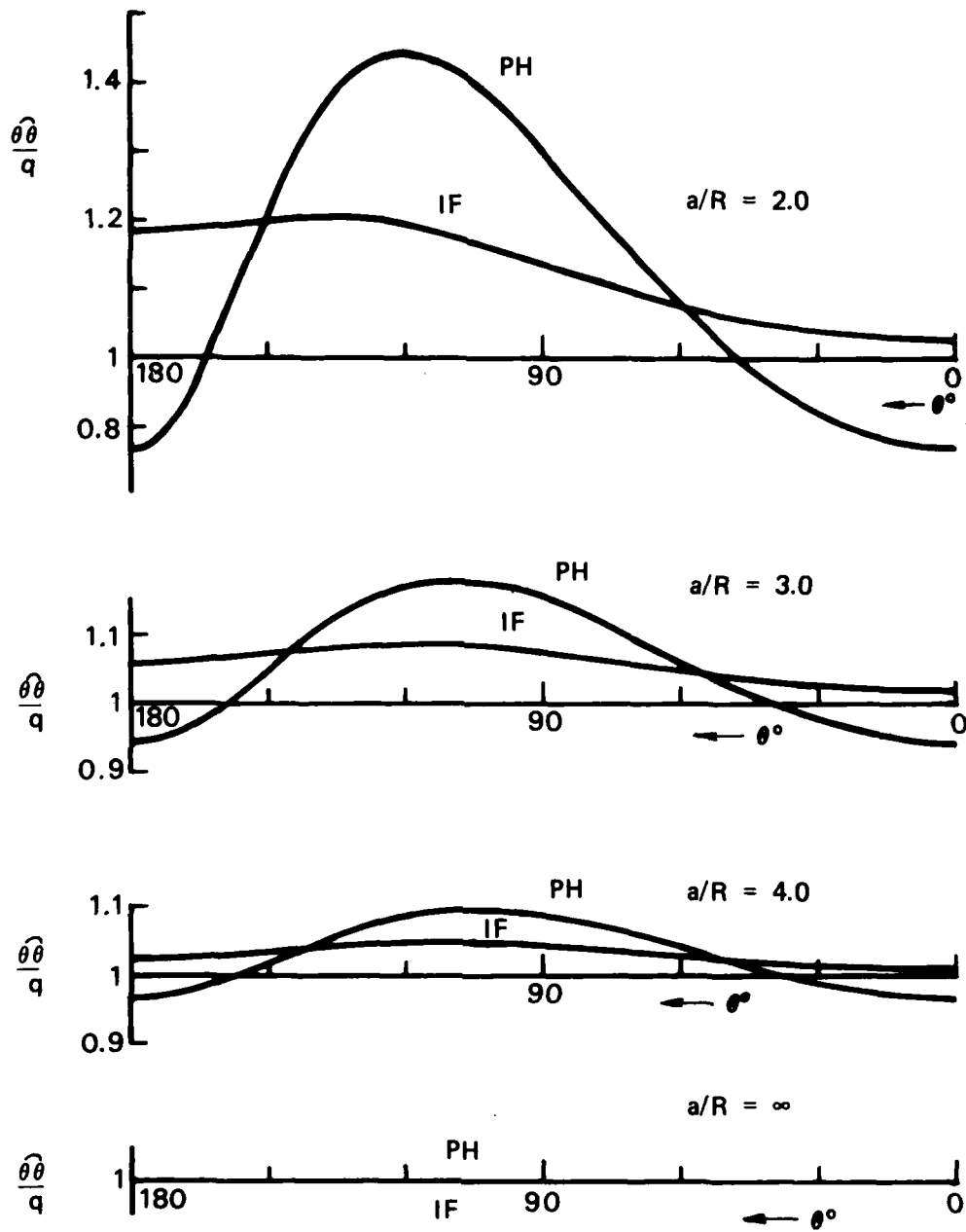

FIG. 9 COMPARISON OF CIRCUMFERENTIAL STRESSES AROUND HOLE FOR PRESSURIZED HOLE (PH) AND INTERFERENCE-FIT DISC (IF) CASES

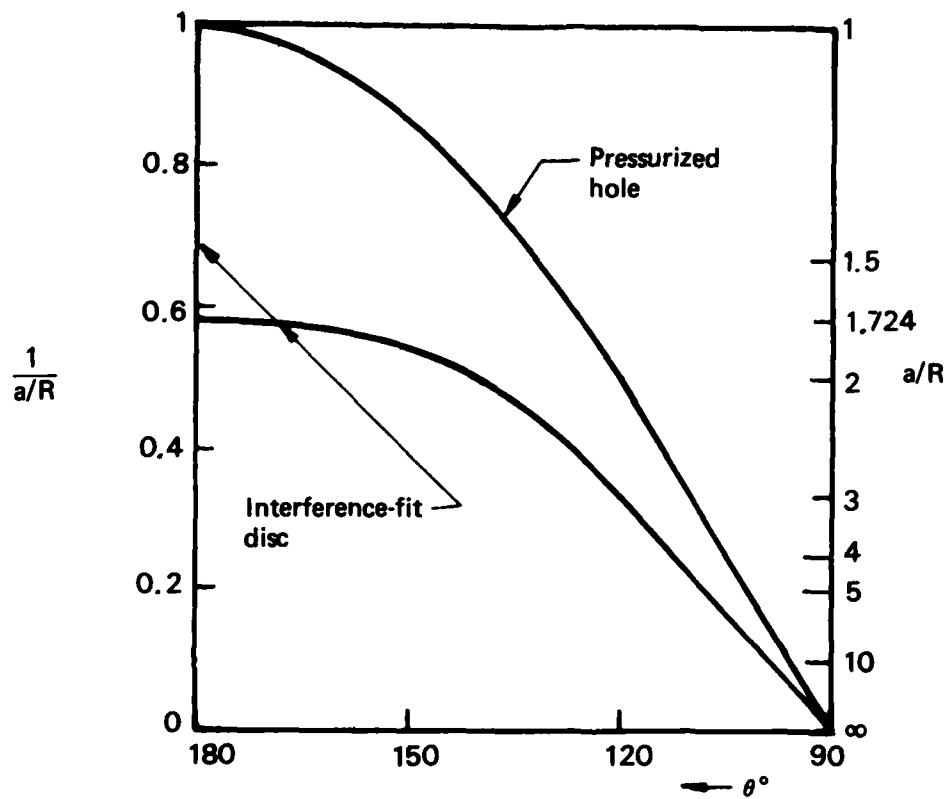

FIG. 10 LOCATION OF MAXIMUM CIRCUMFERENTIAL STRESS AROUND HOLE — PRESSURIZED HOLE AND INTERFERENCE-FIT DISC CASES

DISTRIBUTION

AUSTRALIA

DEPARTMENT OF DEFENCE

Central Office

Chief Defence Scientist
Deputy Chief Defence Scientist
Superintendent, Science and Program Analysis
Controller, External Relations, Projects and Analytical Studies
Defence Science Adviser (U.K.) (Doc. Data sheet only)
Counsellor, Defence Science (U.S.A.) (Doc. Data sheet only)
Defence Central Library
Document Exchange Centre, D.I.S.B. (18 copies)
Joint Intelligence Organisation
Librarian H Block, Victoria Barracks, Melbourne
Director General—Army Development (NSO) (4 copies)

} (1 copy)

Aeronautical Research Laboratories

Director
Library
Divisional File—Structures
Author: G. S. Jost
R. P. Carey
J. Y. Mann
B. C. Hoskin
R. Jones
M. Heller

Materials Research Laboratories

Director-Library

Defence Research Centre

Library

Navy Office

Navy Scientific Adviser

Army Office

Army Scientific Adviser
Engineering Development Establishment, Library
Royal Military College Library

Air Force Office

Air Force Scientific Adviser
Aircraft Research and Development Unit
Scientific Flight Group
Library
Technical Division Library
RAAF Academy, Point Cook

Central Studies Establishment

Information Centre

DEPARTMENT OF DEFENCE SUPPORT

Government Aircraft Factories

Manager
Library

DEPARTMENT OF AVIATION

Library
Flying Operations and Airworthiness Division

STATUTORY AND STATE AUTHORITIES AND INDUSTRY

CSIRO

Materials Science Division, Library
Trans-Australia Airlines, Library
Qantas Airways Limited
Ansett Airlines of Australia, Library
Commonwealth Aircraft Corporation, Library
Hawker de Havilland Aust. Pty. Ltd., Bankstown, Library

UNIVERSITIES AND COLLEGES

Adelaide	Barr Smith Library
Flinders	Library
Latrobe	Library
Melbourne	Engineering Library
Monash	Hargrave Library
Newcastle	Library
Sydney	Engineering Library
N.S.W.	Physical Sciences Library
Queensland	Library
Tasmania	Engineering Library
Western Australia	Library
R.M.I.T.	Library

CANADA

CAARC Coordinator Structures
International Civil Aviation Organization, Library
NRC
Aeronautical & Mechanical Engineering Library

Universities and Colleges

Toronto Institute for Aerospace Studies

FRANCE

ONERA, Library

INDIA

CAARC Coordinator Structures
Defence Ministry, Aero Development Establishment, Library
Hindustan Aeronautics Ltd., Library
National Aeronautical Laboratory, Information Centre

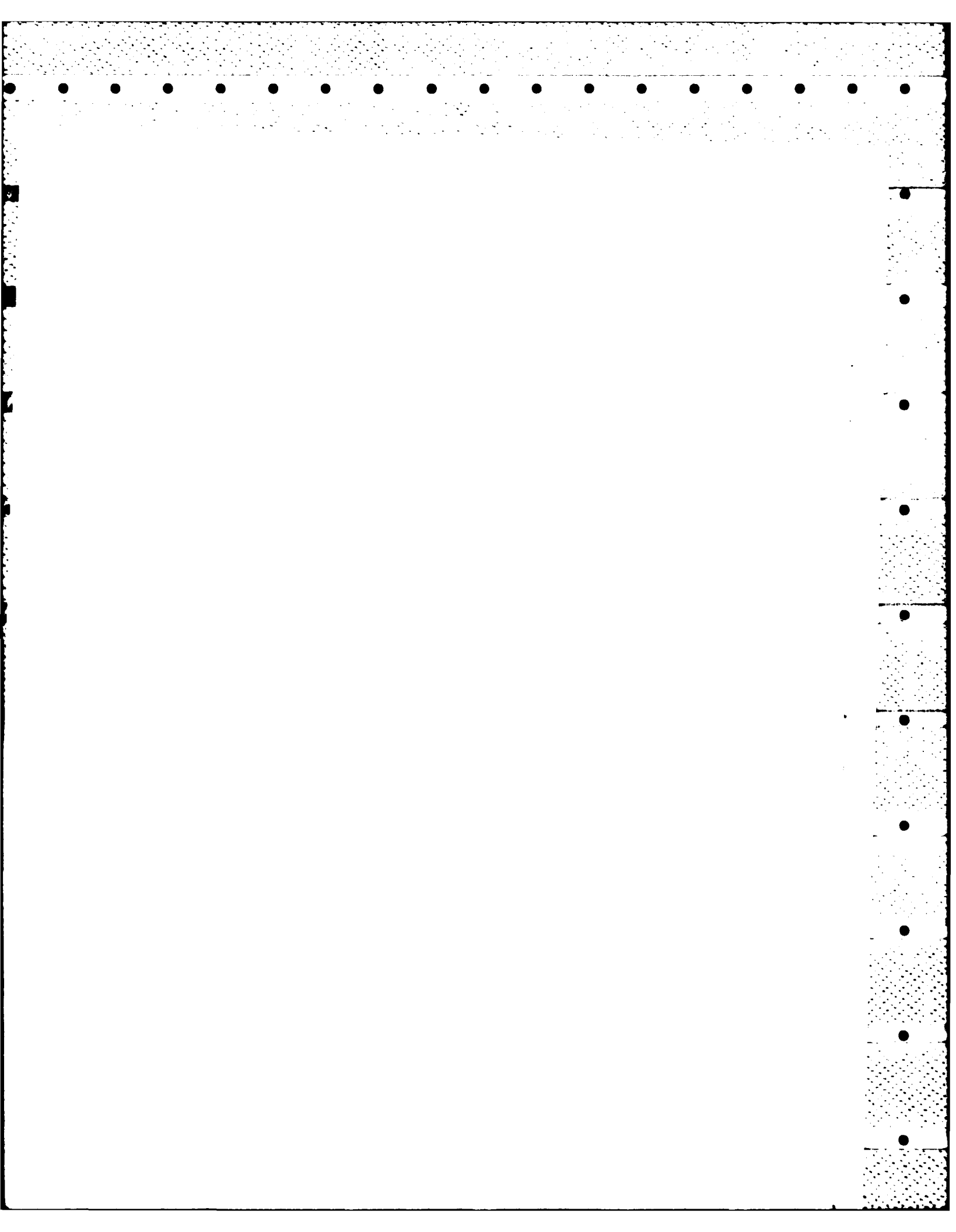

ISRAEL

Technion-Israel Institute of Technology
Professor A. Buch

JAPAN

National Research Institute for Metals, Fatigue Testing Division

NETHERLANDS

National Aerospace Laboratory (NLR), Library

NEW ZEALAND

Defence Scientific Establishment, Library

SWEDEN

Aeronautical Research Institute, Library

SWITZERLAND

F + W (Swiss Federal Aircraft Factory)

UNITED KINGDOM

ESDU International Ltd., London
Ministry of Defence, Research, Materials and Collaboration
CAARC, Secretary
Royal Aircraft Establishment
Bedford, Library
Farnborough, Library
National Physical Laboratory, Library
National Engineering Laboratory, Library
British Library, Lending Division
CAARC Coordinator, Structures
Rolls-Royce Ltd.
Aero Division Bristol, Library
British Aerospace
Kingston-upon-Thames, Library
Hatfield-Chester Division, Library

Department of Defence
DOCUMENT CONTROL DATA

1. a. AR No. AR-003-943	1. b. Establishment No. ARL-STRUC-R-409	2. Document Date July, 1984	3. Task No. DST 83/005
4. Title STRESSES IN A HALF-PLANE CONTAINING EITHER A PRESSURIZED HOLE OR AN INTERFERENCE-FIT DISC		5. Security a. document Unclassified	6. No. Pages 18
		b. title c. abstract U. U.	7. No. Refs 4
8. Author(s) G. S. Jost		9. Downgrading Instructions	
10. Corporate Author and Address Aeronautical Research Laboratories, P.O. Box 4331, Melbourne, Vic., 3001		11. Authority (as appropriate) a. Sponsor c. Downgrading b. Security d. Approval	
12. Secondary Distribution (of this document) Approved for public release			
Overseas enquirers outside stated limitations should be referred through ASDIS, Defence Information Services Branch, Department of Defence, Campbell Park, CANBERRA, ACT, 2601.			
13. a. This document may be ANNOUNCED in catalogues and awareness services available to ... No limitations			
13. b. Citation for other purposes (i.e. casual announcement) may be (select) unrestricted (or) as for 13 a.			
14. Descriptors Stress analysis Interference fitting Elasticity Holes (openings)		15. COSATI Group 11130 01030	
16. Abstract <i>Comparisons have been made of the theoretical stresses in a half-plane containing either a pressurized hole or an interference-fit disc. For a hole more than about three radii from the free edge the differences between the two cases become progressively more insignificant.</i> <i>... stress analysis, ...</i>			

This page is to be used to record information which is required by the Establishment for its own use but which will not be added to the DISTIS data base unless specifically requested.

16. Abstract (Contd)		
17. Imprint Aeronautical Research Laboratories, Melbourne		
18. Document Series and Number Structures Report 409	19. Cost Code 277050	20. Type of Report and Period Covered
21. Computer Programs Used _____		
22. Establishment File Ref(s) _____		

END

FILMED

6-85

DTIC