

AD-A153 745

AIR FREIGHT TERMINAL MHE (MATERIAL HANDLING EQUIPMENT)
REQUIREMENTS MODEL (4/6K FORKLIFTS)(U) AIR FORCE
LOGISTICS MANAGEMENT CENTER GUNTER AFS AL

1/1

UNCLASSIFIED

D E KING ET AL. DEC 84

F/G 13/3

NL



END

FORMED

DTIC

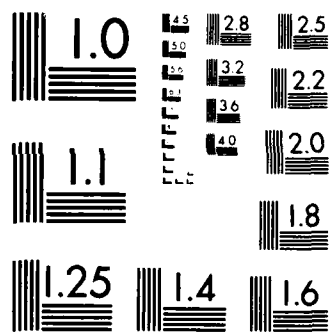

MICROCOPY RESOLUTION TEST CHART
NATIONAL BUREAU OF STANDARDS 1963-A



AIR FORCE LOGISTICS MANAGEMENT CENTER

AD-A153 745

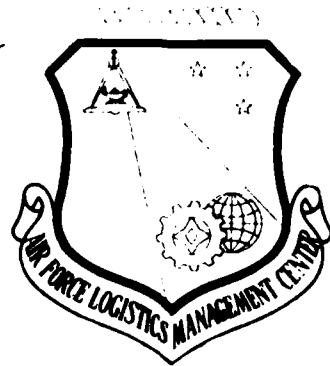

AIR FREIGHT TERMINAL MHE REQUIREMENTS
 MODEL (4/6K FORKLIFTS)

PROJECT NO. 830103

by

Maj Dan E. King
 Lt Barbara A. Yost

Team Member
 Wayne Faulkner

December 1984

DTIC
 ELECTE
 MAY 15 1985

B

AIR FORCE LOGISTICS MANAGEMENT CENTER
 GUNTER AFS, AL. 36114

DTIC FILE COPY

DISTRIBUTION STATEMENT A
 Approved for public release
 Distribution Unlimited

85 4 23 069



DEPARTMENT OF THE AIR FORCE
AIR FORCE LOGISTICS MANAGEMENT CENTER
GUNTER AIR FORCE STATION, AL 36114

REPLY TO
ATTN OF CC

SUBJECT Final Report - Air Freight Terminal MHE Requirement Model (4/6K Forklifts)
AFLMC Project TY830103

TO See Distribution

1. Attached is the final report of the MHE Requirements Model recently completed for HQ USAF/LET.
2. Small forklifts (4K and 6K) are presently authorized and allocated in a way that ignores the impact of the facility layout or the flow of the workload through the air freight terminal. Table of Allowance 010 refers only to gross tonnages and terminal classifications. In most cases, this has satisfied peacetime needs. However, we've run our model against wartime work levels at selected aerial ports and forklift requirements far exceed current authorizations.
3. Our requirements model is easy to use. It prompts the base level managers to assess workload, facility and resource requirements in terms they understand and asks for data they can easily obtain. The model runs in just a few minutes on the Z-100 microcomputer. We believe we have a realistic capability analysis tool which should be used to authorize 4K and 6K forklifts at each aerial port or air freight terminal.
4. Providing new and better management tools to the Transportation and Logistics communities is our goal. Our POC is Major Dan King, AFLMC/LGT, Autovon 446-4464.

EDWIN C. JONES, JR.
Deputy Commander

- 2 Atch
1. Distribution List
2. Final Report

ABSTRACT

We were tasked by HQ USAF/LET to develop a method of establishing requirements for light forklifts (4K and 6K) used in air freight terminals.

Table of Allowance (TA) 010 prescribes peacetime allowances for 4K and 6K forklifts at air freight terminals. Allowances are determined subjectively. However, contingency and WRM forklift allowances are not addressed in TA 010.

The methods currently used to determine allowances in TA 010 and actual requirements can result in the wrong number of light forklifts in our air freight terminals. Too few forklifts can contribute to bottlenecks and backlogs. Too many forklifts can needlessly waste resources.

We developed a model, on the Z-100 microcomputer, to replace the subjective method of determining light forklift requirements. By inputting a range of variables, the local freight terminal manager can describe the specific workload (either peacetime or wartime) and the work environment. The model can also be used by the major command to verify base-level requirements. Contingency planning and wartime requirements can be computed as often as needed to reflect changes in projected cargo flow.

STIC
ELECTE
MAY 15 1985
B

Accession For	
NTIS GRA&I	<input checked="" type="checkbox"/>
DTIC TAB	<input type="checkbox"/>
Unannounced	<input type="checkbox"/>
PER LETTER	
Availability Codes	
Avail and/or	
Special	
A-1	

DISTRIBUTION STATEMENT A
Approved for public release
Distribution Unlimited



EXECUTIVE SUMMARY

Both HQ USAF/LET and HQ MAC expressed concern over the way Material Handling Equipment (MHE) requirements are determined. We were tasked to develop a method of establishing requirements for light forklifts (4k and 6k) used in air freight terminals.

Table of Allowance (TA) 010 prescribes peacetime allowances for 4K and 6K forklifts for air freight terminals. In the TA, freight terminals are classified by tons of cargo processed each month. The classifications range from 1 to 15 for a tonnage of 200-17,500 respectively. These allowances are established by subjective committee action. Also, there are no provisions for contingency or WRM allowances.

In reality, cargo tonnage is but one of the variables which affect the amount of MHE needed. The number of truck arrivals, the period during which arrivals occur, the time required to offload a truck, the number of docks, and number of pallet build-up areas, all play an important part in determining how many light forklifts are needed.

The current subjective method used to determine light forklift requirements can result in the wrong number of vehicles authorized in air freight terminals. Too few forklifts contribute to bottlenecks, backlogs, and wartime shortfalls. On the other hand, too many can needlessly waste resources.

Technology now enables a more reliable way of establishing MHE allowances and requirements than by using a committee's educated guess. Our requirements model, developed on the Air Force standard microcomputer (Z-100), addresses a wide variety of critical variables and allows the air freight terminal manager to tailor the model to a specific location. It is user-friendly and provides answers within minutes. The major command can also use the same model to verify requirements and conduct other transportation planning. The model can be used to determine wartime requirements. Additionally, it can aid in making quick decisions based on changes in cargo or airlift flow. The quick-decision feature is important to the transportation planner during contingencies or when decisions about resource distribution must be made.

We recommend the subjective methods used to develop forklift allowances and requirements be abandoned and the output of the 4K/6K model be used to determine requirements for each air freight terminal. This way authorizations would be tailored specifically to the workload and work environment for a specific location. Updates could be accomplished annually or any time significant mission changes occur.

Additionally, we recommend this model be used to establish WRM requirements for 4K and 6K forklifts at each air freight terminal. The number of forklifts authorized for WRM should be updated on an annual basis or when major OPLAN revisions are made.

The model should be a part of the contingency planning process and employed to assess capability at deploying and reception areas worldwide.

TABLE OF CONTENTS

	<u>PAGE</u>
ABSTRACT.....	1
EXECUTIVE SUMMARY.....	11
TABLE OF CONTENTS.....	111
CHAPTERS	
1 - THE PROBLEM.....	1
Background.....	1
Problem Statement.....	2
2 - DEVELOPMENT.....	3
Approach.....	3
Results.....	3
Run Modes.....	4
Validation.....	5
3 - CONCLUSIONS.....	6
4 - RECOMMENDATIONS.....	7
ATTACHMENTS	
1 - HQ USAF/LETN Tasking Letter	
2 - HQ MAC/LGMV Co-Sponsor Letter	
3 - HQ MAC/TR Co-Sponsor Letter	
4 - Diagram of Cargo Processing Flow	
5 - Example Graph	

CHAPTER 1

THE PROBLEM

SECTION A - BACKGROUND

HQ USAF/LET and HQ MAC expressed concern over the way Material Handling Equipment (MHE) requirements are determined. Subsequent to the February 1982 conference on Table of Allowance (TA) 010 and 463L MHE utilization, the Air Staff tasked us to develop a formula for determining requirements for the following 463L MHE:

- 10K Forklift
- 25K Aircraft Loader
- 40K Aircraft Loader

We completed the project, An Evaluation of Material Handling Equipment Requirements, Project 820201, in August 1982. Acknowledging that study as an important step in developing an objective system for evaluating MHE requirements, the Air Staff then asked us to conduct a continuation study addressing requirements for lighter MHE (4K and 6K forklifts) used in the air freight terminal environment (Atch 1). Headquarters MAC/LG and TR agreed to co-sponsor the study (Atch 2 and 3).

Currently, peacetime allowances for 4K and 6K forklifts for air freight terminals are prescribed in Table of Allowance (TA) 010. The TA classifies terminals by tons of cargo processed each month. The classifications range from 1 to 15 for a tonnage of 200-17,500 respectively. The TA does not provide for contingency or WRM allowances.

Cargo tonnage is but one of the many variables which affect the amount of MHE needed. Variables such as number of truck arrivals, the period over which arrivals occur, the time required to off-load a truck (this could be affected by facilities), the number of docks, and number of pallet build-up areas, etc.; all play an important part in determining how many light forklifts are needed.

A MAC Research Associate assigned to the Center for Aerospace Doctrine, Research, and Education, Airpower Research Institute, studied the problem of determining MHE allowances and requirements. The report, The Impact of Materials Handling Equipment on Airlift Capabilities, August 1983, recognized the weaknesses of the current system; however, it did not provide solutions. It merely concluded the Air Force "must determine if a formula can be built for determining quantities of MHE for peacetime and wartime requirements." An AFIT study, Aerial Port of Embarkation Capability Planning, Volume I, September 1983, detailed the Air Force's failure to adequately define and standardize what will be needed to support surges during contingency and wartime conditions. Virtually all elements of support, equipment, manpower, and facilities, are forecasted by subjective methods. Hence, considerable doubt exists in our capability to meet planned through-puts during surges.

The capability to forecast retrograde handling capability is also necessary. In a recent USAF Inspector General report, Functional Management

Inspection of Transportation Contingency Planning, PN 83-612, 21 Mar 83 - 14 Feb 84, a major shortfall in retrograde planning was found and an urgent need to address this problem was indicated. They wrote:

Some major aerial ports of debarkation (APODs) had not planned for any retrograde workload. Facilities (especially holding space) and manpower could be adversely affected by the retrograde tonnage. Other transportation units had not forecasted a "worst case" scenario in planning transportation requirements. Surface movement of retrograde tonnage to APODs had not been addressed at all. Retrograde impacted on transportation resources and required more finite planning. Finally, the impact on CONUS transportation units concerning onward movement of retrograde was not readily apparent nor did it appear to have been seriously considered.

Clearly, improvements in forecasting essential cargo movement requirements are needed.

SECTION B - PROBLEM STATEMENT

The Basis of Issue (BOI) in Air Force's Table of Allowances for 4/6K forklifts at air freight terminals are presently based on a single variable-- cargo tonnage. Requirements are then determined by committee action and technical experts. This method is highly subjective and can result in having the wrong number of vehicles in our terminal facilities.

CHAPTER 2

DEVELOPMENT

SECTION A - APPROACH

The objective of this project was to develop a model which relies less on expert opinion and more on meaningful workload variables. We quickly realized the number of critical variables which had to be considered could not be accommodated by a simple formula. Additionally, the use of the 4K and 6K forklifts change constantly as cargo flows through the air freight terminal system. Because of the constant changes, queuing theory equations could not be used. Consequently, we chose to use a simulation model.

SECTION B - RESULTS

This is not an optimization model which simply considers inputs and then announces the exact number of light forklifts needed. Rather, the user is asked to describe the air freight terminal's work load, resources, and constraints. The workload is defined by the arrival period of cargo, the number of trucks and planes arriving in that time period and the amount of cargo each holds. Resources include number of forklifts, truck docks, 463L pallet pits and floor space assigned to cargo holding areas. Service times for each action in the terminal, incommision rate for the forklifts, and the percent of cargo sent to various holding areas constitute the constraints of the terminal. There are thirty variables used to describe the workload and terminal. These variables can be readily determined by terminal managers with existing documentation or physical measurement. The model then tells the user how many work hours will be required to accomplish the workload. It also tells the user how certain resources were used. This means the user can distribute and prioritize his resources as required and forecast the impact. Multiple runs of the model shows graphically the relationship between the number of forklifts and the number of required work hours. Other resources (docks, pits, incommision rates, etc) can also be varied and graphed against the work hours.

The physical characteristics of the air freight terminal and the cargo flow through the terminal are used by the model in the following manner (see Atch 4). The terminal is divided into two main areas: inbound and retrograde. Trucks arrive and are distributed by a random (poisson) arrival pattern described by the number of arrivals and the duration of the arrival times. If an unloading dock is not available, the truck joins a queue until one opens up. Once a truck arrives at a dock, the next task is to assign a forklift if one is needed. Some trucks may not need a small (4K or 6K) forklift to unload, because either the cargo is prepalletized, requiring a larger forklift or pallet dolly, or the amount of cargo is very small and can be handled by hand. Cargo is off-loaded and then moved directly to the inbound holding areas or pallet build-up area.

When there is enough cargo in a holding area to build a pallet, the cargo is moved to the build-up area and a 463L pallet is built. Should the holding

areas fill to capacity, cargo flow into the holding areas stops; i.e., truck off-loading and pallet breakdown is stopped until cargo is moved out of holding areas to the build-up areas. The model assumes resources, other than 4K/6K forklifts, are available to remove the completed 463L pallet from the build-up areas. The model considers one forklift as adequate to off-load a truck. Two forklifts may move cargo from the holding areas to the build-up areas.

The retrograde cargo flow is very similar to the in-bound cargo flow. Planes arrive at random (exponential) time intervals set by the period of arrival times and the number of arrivals expected. The model assumes there is equipment (10K forklift, 25K loader, or 40K loader) available to off-load the planes and bring the pallets to the terminal. These pallets then join the queue awaiting break down in a pit. After placement in pits, the pallets are worked by as many forklifts as available. The cargo is in-processed and moved to either the pallet build-up pits, inbound or retrograde holding areas. The amount going to the inbound holding areas is dictated by the ratio of air to surface outbound cargo, a condition input by the model user. Should one of these holding areas fill to capacity, only pallet breakdown is stopped. Small forklifts (4K and 6K) are allocated to the congested holding areas until the bottleneck is relieved.

This model has the following assumptions: Personnel are always available, and larger MHE is always available to move 463L pallets around the terminal. Simulation is based on queuing theory. The times between arrivals and service times are exponentially distributed, so the arrivals are generated by a poisson distributor. The work is done on a first in-first out basis.

The results of the model can tell the user if there are adequate docks, MHE, holding areas and build-up/break-down pits available to meet the work load. It identifies specific shortfalls in any of these areas. The total time period to clear the terminal is given as well as the average working time for each forklift. The number of personnel required is not calculated; however, you can determine the number of personnel you will need based on the number of forklifts and the average number doing a task during the day. The output of the terminal is measured by 463L pallets built and trucks loaded. Statistics are given for the queues formed outside the terminal waiting for docks and pits and inside the terminal waiting for a forklift in a dock or pit. Since the model assumes a pool of forklifts available to work anywhere they are needed, the average number of forklifts working in an area is calculated. Utilization rates of docks and pits shows if there are too few for the work load. Lastly, the average amount of cargo in each holding area shows if enough floor space is dedicated for the volume of cargo going to that area.

SECTION C - RUN MODES

There are three run modes for the model. In the first, the model is given a set of inputs, makes a run with a fixed number of repetitions, and gives a set of outputs as described above. In the second mode, the inputs can be varied to obtain different outputs. Based on these outputs, a graph can then be plotted of the total time to complete the work load and

the average work time per forklift against the variable number of forklifts (see Atch 5). The third mode is a multiple-day run where variables are evaluated over the number of days under consideration. Detailed instructions for manipulating the model can be found in the user's guide.

The model was developed on an IBM 4331 mainframe and has been transferred to the Z-100 microcomputer. It is made up of approximately 4000 lines of Fortran code. To do a single run takes 3-5 minutes. To do a multiple run and produce a chart takes approximately one hour (eleven runs times 5 minutes per run).

SECTION D - VALIDATION

We have tested this model against selected aerial ports and air freight terminals. Visits to Dover AFB and Travis AFB have shown that the model simulates their day-to-day operations. To show the model also works on a smaller scaled terminal, we also ran it with inputs from the McClellan and Warner Robins' air freight terminal. In all tests the results showed a close simulation of the day-to-day operations. Total cargo processing time, the amount of cargo left over each day, and use factors of docks, pits and holding areas were representative of actual figures. Outputs such as the number of 463L pallets built and trucks loaded mirrored the output of the terminals. This consistency indicates the model accurately addresses the key indicators associated with processing cargo through Air Force air freight terminals. It also demonstrates that peacetime MHE requirements at these locations have been refined over the years using a system predicated on, "Let's try this number and see how it works."

In addition, we input wartime work load into the model. The output indicated huge disparities exist between the capabilities of existing resources and wartime requirements. We found authorized light MHE would be required to operate 24 hours a day and would still not be able to meet cargo movement needs. The model shows similar shortfalls in the number of docks, holding areas and pits. Additionally, based on wartime work schedules, the number of trained work crews are inadequate to meet the challenge.

The strength of the model is its use after significant mission changes or facility modifications at a specific installation, the establishment of a new air freight terminal or the determination of wartime and contingency requirements.

CHAPTER 3

CONCLUSIONS

We believe this model should be adopted to determine 4K/6K forklift requirements. The model addresses a wide variety of critical variables and allows the freight terminal manager to tailor the model to his specific location. It is user-friendly and provides answers within minutes. The major command can use the same model to verify requirements and conduct other transportation planning.

The model is responsive enough to make immediate decisions based on changes in cargo or airlift flow. This latter feature offers new options for the transportation planner when rapid decisions about resource distribution must be made.

Use of the model to establish TO 010 allowances provides a more creditable Basis of Issue (BOI) for the 4K and 6K forklifts at air freight terminals. The model computes more accurate levels of MHE than the current system of cargo tonnage per month.

CHAPTER 4
RECOMMENDATIONS

1. Approve the 4K/6K forklift model as a replacement for the subjective allowance method in TA 010. (OPR: AF/LET; OCRs: AF/LEY, WR-ALC/MMM)
2. Approve using the 4K/6K model to determine WRM requirements at air freight terminals. (OPR: MAJCOM LGs)
3. Direct a change in the basis of issue in TA 010. Specify the 4K/6K model as the preferred method of determining air freight terminal MHE authorizations for day-to-day and WRM requirements. (OPR: AF/LET; OCR: AF/LEY)
4. Use the 4K/6K at each air freight terminal to forecast peacetime and wartime requirements. (OPR: MAJCOM LGs)
5. Update 4K/6K authorizations on an annual basis or whenever major mission or OPLAN revisions occur. (OPR: MAJCOM LGs)



DEPARTMENT OF THE AIR FORCE
HEADQUARTERS UNITED STATES AIR FORCE
WASHINGTON, D C

9 DEC 1982

REF TO
ATTN OF LETN

Request for the Development of an Aerial Port MHE Model (AFLMC
Project 820201)

TO
AFLMC/LGT

1. A recommendation in your 5 August report was that the Air Force develop an aerial port MHE model which will fully identify the critical variables in materials handling equipment requirements.
2. Request that AFLMC take this recommendation as a continuation of the original study. The original study was an important step in the development of an objective system for evaluating MHE requirements. Thank you for your assistance.

FOR THE CHIEF OF STAFF

C. M. CUNNINGHAM, Jr., Col, USAF
Chief, Vehicle & Equipment Div
Directorate of Transportation

ATCH 1



DEPARTMENT OF THE AIR FORCE
HEADQUARTERS MILITARY AIRLIFT COMMAND
SCOTT AIR FORCE BASE, ILLINOIS 62325

لرز

1933

14 JUL 1933

- 1. LGMV (Maj Riter, 3147)
- 2. Co-Sponsorship of Aerial Port MHE Requirements Model (4/6K Forklifts) (Your Ltr, 29 Jun 83)
- 3. AMASC/CC

This confirms HQ MAC/LGM acceptance as co-sponsor of the Aerial Port MHE Requirements Model (4/6K Forklifts).

William D. Leachman

WILLIAM D. LEACHMAN, Colonel, USAF
Deputy Dir of Maint Engineering



DEPARTMENT OF THE AIR FORCE -
HEADQUARTERS MILITARY AIRLIFT COMMAND
SCOTT AIR FORCE BASE, ILLINOIS 62223

13 JUN 1983

TR

Co-Sponsorship of Aerial Port MHE Requirements Model (4/6K Forklifts)
(Your Ltr, 29 Jun 83)

AFMNC/CC

Concur with co-sponsorship of Aerial Port MHE Requirements model (4/6K
forklifts). Point of contact is Lt Col Stephen W. Wilkin, TRXF/4697.

EDDIE B. LADD, Col, USA
Assistant DDC/Air Transportation

AIR 3

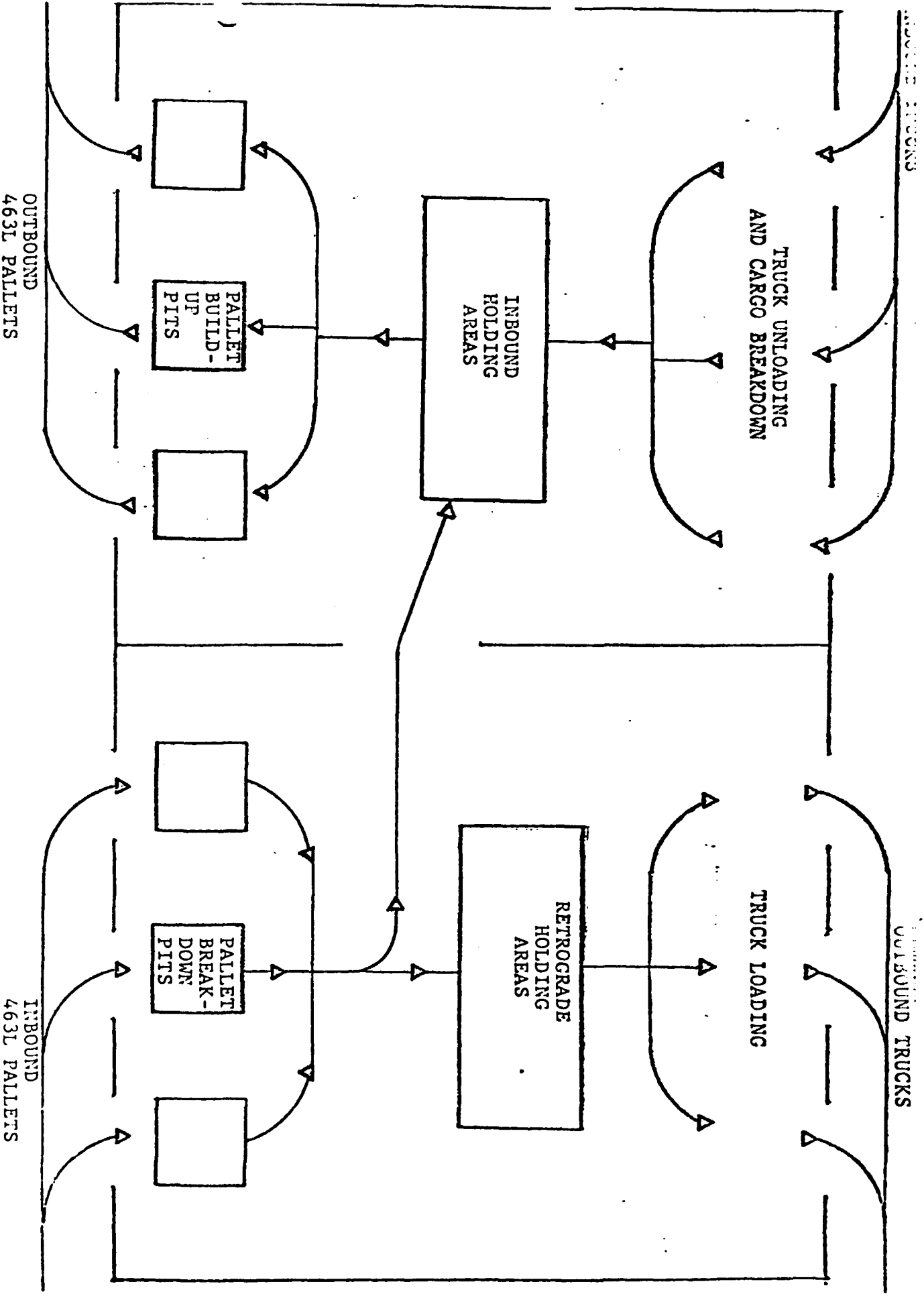

TOTAL WORK TIME

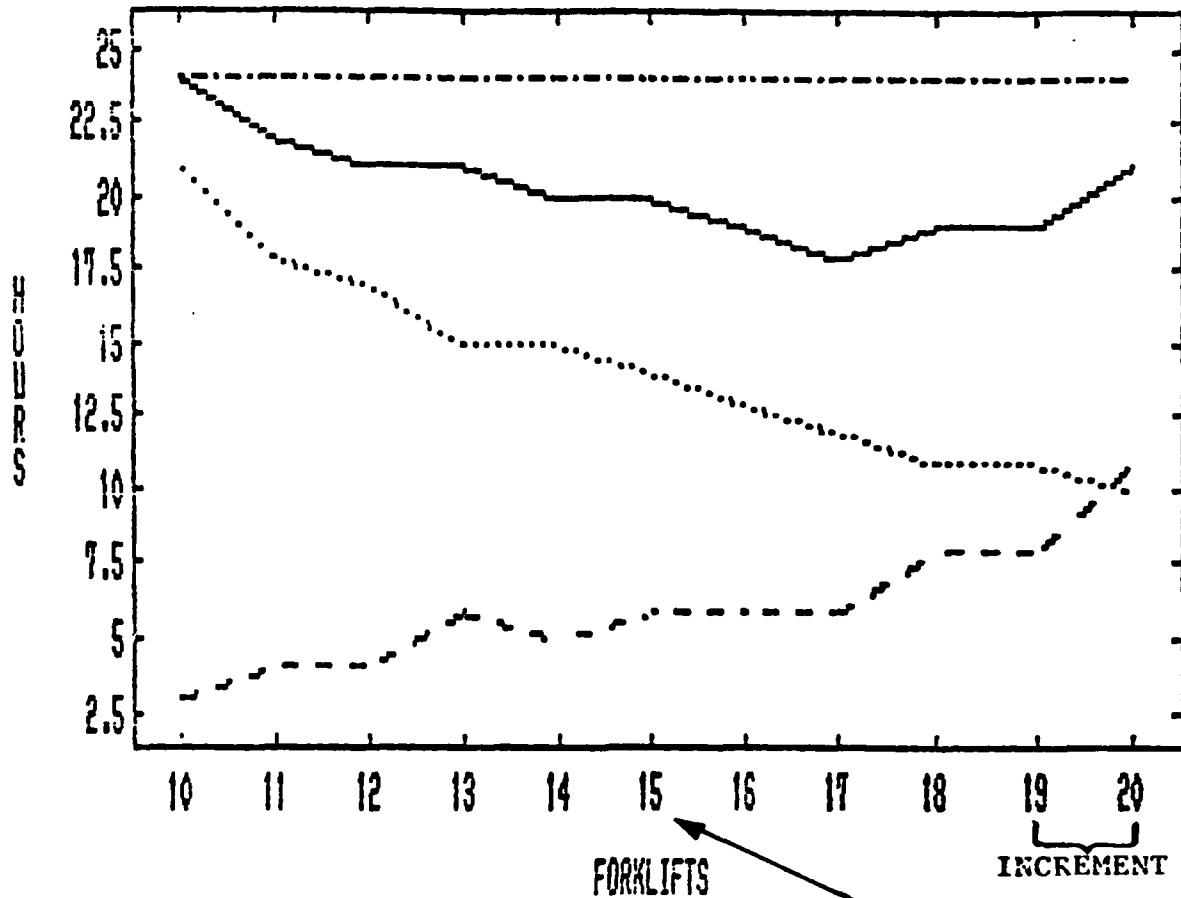

- TOTAL WORK TIME
- - - AVE IDLE TIME
- AVE WORK TIME
- · - · 24 HOURS

DISTRIBUTION LIST

Air University Library (AUL)
Maxwell AFB Al 36112

AFHRL/LRS TDC
Wright-Patterson AFB OH 45433

AFIT/LS
Wright-Patterson AFB OH 45433

Defense Logistics Studies Information
Exchange
U.S. Army Logistics Management Center
Fort Lee VA 23801

Defense Technical Information Center
Defense Logistics Agency
Cameron Station Alexandria VA 22314
Alexandria VA 22314

National Technical Information Service
5285 Port Royal Road
Springfield VA 22161

END

FILMED

6-85

DTIC