

AD-A153 752

SURFACE ACOUSTIC WAVE DEVICES AS CHEMICAL VAPOR
MICROSENSORS(U) NAVAL RESEARCH LAB WASHINGTON DC
H WOHLTJEN ET AL. 18 APR 85 NRL-MR-5538

1/1

UNCLASSIFIED

F/G 9/1

NL

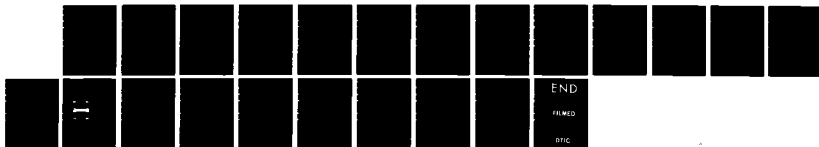

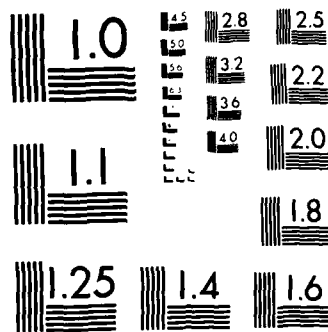

MICROCOPY RESOLUTION TEST CHART
NATIONAL BUREAU OF STANDARDS 1963-A

2

NRL Memorandum Report 5530

AD-A153 752

Surface Acoustic Wave Devices as Chemical Vapor Microsensors

H. WOHLTIEN, A. W. SNOW* AND N. L. JARVIS

*Surface Chemistry Branch
Chemistry Division*

**Polymeric Materials Branch
Chemistry Division*

April 18, 1985

ADA153752

DTIC FILE COPY

DTIC
MAY 15 1985
B



NAVAL RESEARCH LABORATORY
Washington, D.C.

Approved for public release, distribution unlimited

REPORT DOCUMENTATION PAGE				
1a REPORT SECURITY CLASSIFICATION UNCLASSIFIED		1b RESTRICTIVE MARKINGS		
2a SECURITY CLASSIFICATION AUTHORITY		3 DISTRIBUTION/AVAILABILITY OF REPORT Approved for public release; distribution unlimited.		
2b DECLASSIFICATION/DOWNGRADING SCHEDULE				
4 PERFORMING ORGANIZATION REPORT NUMBER(S) NRL Memorandum Report 5530		5 MONITORING ORGANIZATION REPORT NUMBER(S)		
6a NAME OF PERFORMING ORGANIZATION Naval Research Laboratory	6b OFFICE SYMBOL (if applicable) Code 6170	7a NAME OF MONITORING ORGANIZATION		
6c ADDRESS (City, State, and ZIP Code) Washington, DC 20375-5000		7b ADDRESS (City, State, and ZIP Code)		
9a NAME OF FUNDING/SPONSORING ORGANIZATION U.S. Army CRDC	8b OFFICE SYMBOL (if applicable)	9 PROCUREMENT INSTRUMENT IDENTIFICATION NUMBER		
9c ADDRESS (City, State, and ZIP Code) Aberdeen Proving Grounds, MD		10 SOURCE OF FUNDING NUMBERS		
		PROGRAM ELEMENT NO	PROJECT NO	TASK NO
				WORK UNIT ACCESSION NO DN180-445
11 TITLE (Include Security Classification) Surface Acoustic Wave Devices as Chemical Vapor Microsensors				
12 PERSONAL AUTHOR(S) Wohltjen, H., Snow, A.W. and Jarvis, N.L.				
13a TYPE OF REPORT Interim	13b TIME COVERED FROM 10/82 TO 10/83	14 DATE OF REPORT (Year, Month, Day) 1985 April 18	15 PAGE COUNT 22	
16 SUPPLEMENTARY NOTATION				
17 COSATI CODES		18 SUBJECT TERMS (Continue on reverse if necessary and identify by block number)		
FIELD	GROUP	SUB-GROUP		
			Chemical microsensor Piezoelectric	
			Surface Acoustic Wave Device	
19 ABSTRACT (Continue on reverse if necessary and identify by block number) <p>This paper describes some of the operational characteristics and performance limitations of microfabricated sensors for chemical vapors which use surface acoustic wave (SAW) phenomena to probe a vapor sensitive coating. Comparisons are made with bulk wave piezoelectric crystal sensors and key technical challenges for future development of SAW vapor sensors are discussed.</p>				
20 DISTRIBUTION/AVAILABILITY OF ABSTRACT <input checked="" type="checkbox"/> UNCLASSIFIED/UNLIMITED <input type="checkbox"/> SAME AS RPT <input type="checkbox"/> DTIC USERS		21 ABSTRACT SECURITY CLASSIFICATION UNCLASSIFIED		
22a NAME OF RESPONSIBLE INDIVIDUAL H. Wohltjen		22b TELEPHONE (Include Area Code) (202) 767-3321	22c OFFICE SYMBOL Code 6175	

SURFACE ACOUSTIC WAVE DEVICES AS CHEMICAL VAPOR MICROSENSORS

Introduction

The recent revolution in microelectronics has created a need for sensors which are compatible with microcomputers in terms of size and cost. "Microsensors" are emerging as the key elements of intelligent systems intended to monitor or control a vast spectrum of physical, chemical, and biological processes. At the present time, numerous microsensors are commercially available to monitor such physical variables as temperature, pressure, dielectric properties, magnetic fields, light intensity, and images in the IR or visible region. Very little is commercially available for the detection of chemical species although some microsensors such as Chemfets and ISFETS are in the advanced development stage. Microsensors for biological species are only beginning to be investigated. The requirement that a microsensor be microcomputer compatible in terms of size and cost demands that the potential microsensor be fabricatable using photolithographic techniques. This suggests that successful microsensors will probably utilize 2 dimensional structures (or at least relatively flat structures) for the critical sensing mechanism. Sensors conceived using this 2 dimensional approach will be able to take advantage of the exquisite dimensional control and small size capability of the photolithographic method. Since the sensitive area of the microsensor is a surface, it is apparent

Manuscript approved January 4, 1985.

that surface modification with coatings is of paramount importance.

Historical Background

Surface waves were discovered by Lord Rayleigh in 1885 and were of interest primarily to seismologists up until the 1960's when White and Voltmer discovered a simple technique for generating surface waves in piezoelectric materials using an interdigital electrode transducer. This sparked an enormous amount of activity to use Rayleigh wave phenomena for radio frequency signal processing applications. This was due to the fact that acoustic waves in piezoelectric materials have wavelengths which are about 10^5 times smaller than the corresponding electromagnetic wave. Thus, SAW devices offer considerable potential as miniature delay lines, resonators, filters, convolvers, etc. An excellent review of SAW technology can be found in references (1) and (2).

The first report of a SAW device being utilized as a chemical sensor was published in 1979 by a group at Virginia Polytechnic Institute (3,4). A SAW delay line oscillator coated with an organic film was used as a detector for gas chromatography. Work has also been conducted at the University of California at Berkeley by Fertsch, White and Muller who used a polymer coated SAW device to sense solvent vapors (5,6). In 1982, Chuang, White and Bernstein of Berkeley reported on a novel thin membrane SAW device sensing application (7). A very sensitive detector for SO_2 vapor (less than 100 ppb) was reported by Bryant, Lee and Vetelino at the University of Maine

in 1981 (8). This group also compared the SAW response with that of a bulk wave sensor and found the SAW device to be significantly more sensitive. In 1982, D'Amico, Palma, and Verona reported the detection of hydrogen with a palladium coated SAW device (9).

Interest in SAW device vapor sensors is growing for several reasons. The devices themselves are quite small, very rugged, and simple to fabricate. When produced in large volumes (e.g., more than 1000) the devices could cost less than several dollars. Most importantly, the fabrication technology permits the simultaneous production of several devices on the same substrate. This is valuable for array sensors with compensation for temperature, pressure or interference vapor effects.

Device Operating Mechanism

The SAW device consists of a small slab of a polished piezoelectric crystal which can range in size from less than a square millimeter to several square centimeters in area. Two sets of interdigital electrodes are microfabricated onto opposite ends of the surface of the substrate (figure 1). Ordinarily, this is done using standard photolithographic techniques. For example, a thin film of metal (e.g., aluminum) is evaporated onto the surface, coated with a photoresist film, exposed to light through an optical mask having the electrode pattern, developed, and then etched to remove all of the metal except where electrodes are desired.

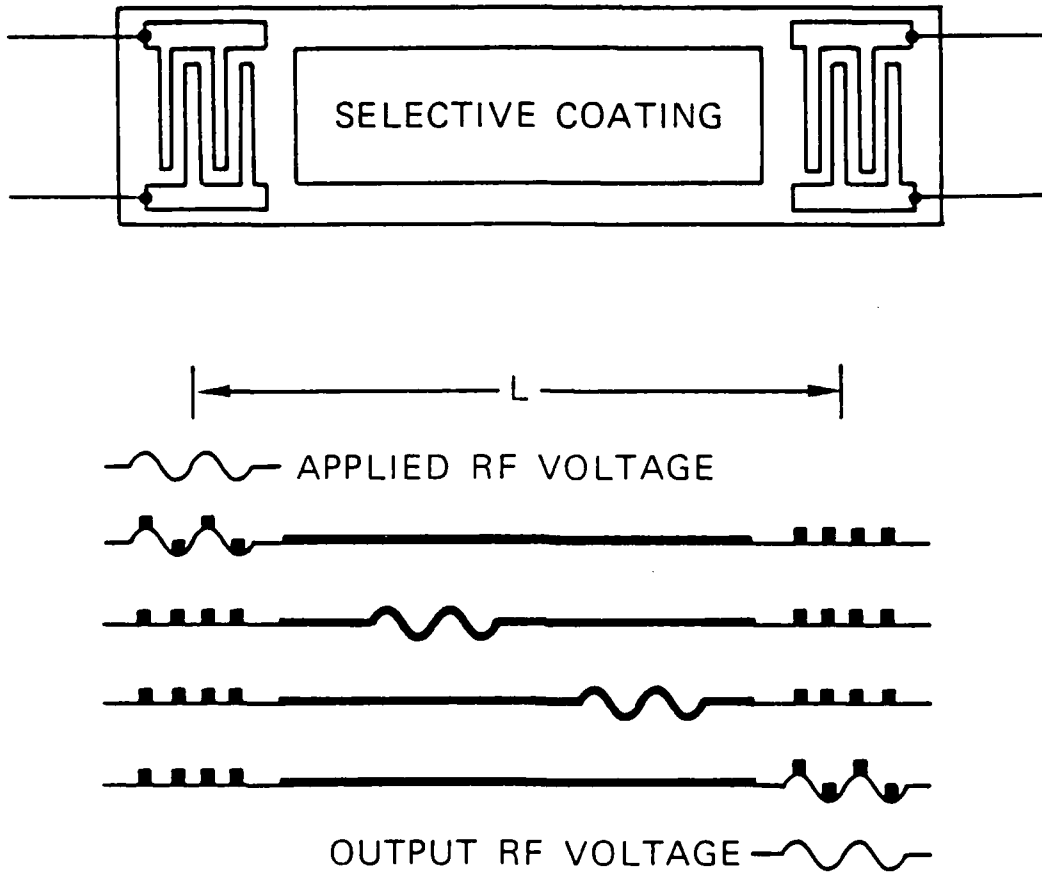

Fig. 1: Top and side view of a SAW delay line showing Rayleigh wave generation, propagation, and detection.

When a set of interdigital electrodes is excited with a radio frequency (RF) voltage, a mechanical Rayleigh surface wave is generated which then propagates across the substrate until it is received by the other set of electrodes and is converted back into an RF voltage. If matter is present on the surface where the wave is propagating then an interaction will occur which modifies some characteristic of the wave. Experimentally, it is most convenient to measure changes in the amplitude or velocity of the wave. A vapor sensor is made by coating the region between the interdigital electrodes with a film which selectively interacts with the vapor of interest.

Measurements of SAW amplitude are conducted by driving the device from an RF voltage source and measuring the power output at the receiving transducer. There are no simple quantitative models which allow one to accurately predict the attenuation produced by a given viscoelastic organic film on a given SAW device. Qualitatively, it is observed that as film thickness increases or SAW frequency increases, so does the attenuation. The attenuation is also quite sensitive to the viscoelastic properties of the coating. One also observes that 'softer' films absorb more energy than 'stiffer' films. Clearly, a solvent vapor diffusing into a polymeric coating on a SAW device can cause dramatic changes in the viscoelastic properties of the polymer and hence amplitude changes in the wave. It turns out, however, that for vapor sensing applications, the measurement of SAW amplitudes is not the best approach. Experimentally, it is only possible to measure SAW amplitudes with a precision of about

1 part in 10^4 . Measurement of SAW velocities can be achieved with a precision of 1 part in 10^8 . Thus, while amplitude changes can be useful, the measurement of wave velocity changes is a far more precise approach and one which is most often used (10).

SAW velocity changes are measured most easily by using the SAW device as the resonating element of an oscillator (figure 2). If one connects the output interdigital transducer to the input interdigital transducer through an RF amplifier, then the system will oscillate at a frequency determined by the electrode finger spacing and the velocity of the Rayleigh surface wave. A typical interdigital electrode could have 50 'finger' pairs with each finger 25 micrometers wide and spaced 25 micrometers from the next finger. Such an array would have an acoustic wavelength of 100 micrometers, and if ST-quartz is the piezoelectric substrate being used (Rayleigh wave velocity = 3158 m/sec), then a resonant frequency of approximately 31.58 MHz would be obtained (since $f = v/\lambda$). Thus, small perturbations in the wave velocity show up as small perturbations in the oscillator frequency.

A detailed quantitative analysis of SAW oscillator behavior (10) shows that the frequency shift obtained from a SAW oscillator coated with a thin film depends on the mass per unit area of the coating and the mechanical properties (e.g., shear modulus) of the coating. For coatings which are viscoelastically 'soft' (e.g., most organic coatings), it is possible to neglect the contribution of the film's mechanical properties and arrive at a very simple relationship which describes the behavior of a SAW oscillator subjected to a given mass loading (equation 1).

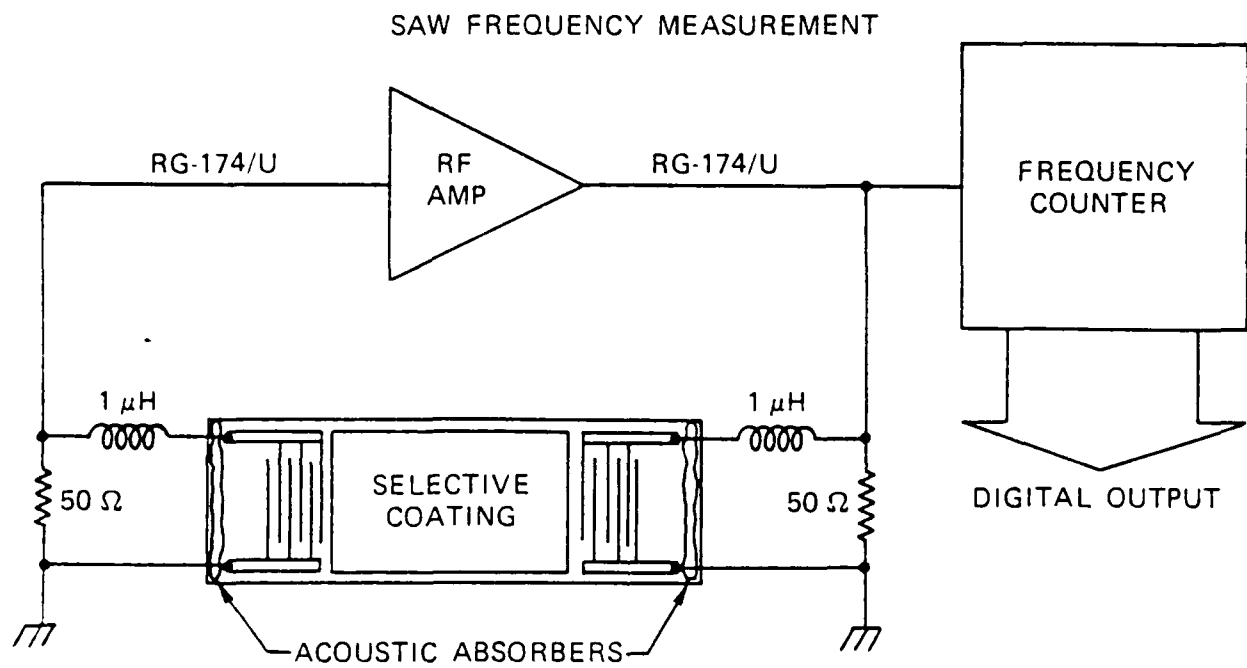

Fig. 2: Typical SAW delay line configuration (31 MHz).

$$\Delta f = k f_0^2 (\Delta W/A) \quad (1)$$

This equation indicates that for a given operating frequency in MHz (f_0) and SAW substrate (material constant - k), the signal in Hertz (Δf) obtained is directly related to the change in mass (ΔW) per unit area (A) of the sensing surface. These results are functionally equivalent to those obtained for the bulk wave piezoelectric quartz crystal microbalance detectors first described by King and investigated extensively by Guilbault and coworkers (11,12).

Comparison of SAW and Bulk Wave Sensors

Since the SAW device and bulk wave piezoelectric crystal both act primarily as mass sensors when used as an oscillator, it is possible to compare them. King has reported (11) that the following expression can be used to predict the frequency change produced by a given mass loading of a quartz crystal bulk wave oscillator:

$$\Delta f = (-2.3 \times 10^6) f_0^2 (\Delta W/A) \quad (2)$$

The corresponding expression for a YX quartz SAW device (10) has been determined to be:

$$\Delta f = (-1.3 \times 10^6) f_0^2 (\Delta W/A) \quad (3)$$

At first glance, the bulk wave device appears to be almost twice as sensitive as the SAW device. However, the SAW device has greater potential sensitivity because the operating frequency (f_0) can be substantially higher. Practical bulk wave devices have an upper limit to their fundamental resonant frequency of about 20 MHz. SAW devices, on the other hand, are quite easily fabricated having fundamental resonance frequencies greater than

300 MHz. Indeed SAW devices operating at 3 GHz have been reported, but the RF amplifiers used to drive these devices are quite exotic. Comparing a 15 MHz bulk wave quartz crystal sensor with a 300 MHz quartz SAW sensor one realizes that for a given mass loading, the SAW device is about 220 times more sensitive. Bryant, Lee and Vetelino (8) performed experiments using a 60 MHz LiNbO_3 SAW device and an 11 MHz AT quartz bulk wave device as a sensor for SO_2 vapor. Both devices were coated with triethanolamine. The SAW sensor was observed to be about 13 times more sensitive than the bulk wave sensor (133 Hz/ppm SO_2 vs. 10 Hz/ppm SO_2). Using the material constants for LiNbO_3 (i.e. $k = 0.55 \times 10^6 \text{ cm}^2 \text{ Hz/gm MHz}^2$), one is led to predict that the SAW device should have been about 7 times more sensitive. In spite of the differing quantitative results between theory and experiment, one point is clear; the SAW device has greater sensitivity due to the higher operating frequency.

The SAW device has other advantages including significantly smaller size and only one active surface. This means that the device can be rigidly mounted (e.g., by glue on one side of the device) and that very small volumes can be monitored. The small size also makes it possible to fabricate multiple devices on the same substrate yielding an array of chemical sensors or sensors to compensate for environmental effects. All of these factors suggest that SAW devices are the most desirable technology to use in sensors based on the microbalance approach.

Alternative SAW Microsensor Configurations

Until now, this paper has only considered single SAW device

sensors using the delay line configuration. There are numerous other SAW devices which are potentially useful in sensor applications. It was noted that frequency measurements offer the greatest precision. It is appropriate therefore to consider SAW resonator structures rather than delay line structures for sensors. A SAW resonator differs from a SAW delay line in that it offers a considerably higher resonant Q and thus greater stability. While a detailed description of the design and operation of SAW resonators is beyond the scope of this paper, it is useful to point out that the size, cost, and sensitivity of a resonator sensor should be comparable to a delay line device. Interested readers can find more information in reference (2).

By far, the most important alternative configuration involves the use of two delay lines on the same substrate; one being used as the sensor and other being used as a reference (figure 3). Such a structure was used by Bryant, Lee, and Vetelino in their work (8). This device has two important advantages. First, it provides an 'on chip' reference frequency which can be heterodyned with the active sensor frequency to provide an easily measured low frequency difference signal. For example, a dual delay line device may have one delay line resonating at 250 MHz and the other (coated) device resonating at 249.8 MHz. Accurate measurement of each signal requires a very high speed frequency counter. However, if the signals are heterodyned together in a simple RF mixer circuit, a difference frequency of 0.2 MHz would be produced which could be measured precisely and easily with a very simple frequency counter occupying one integrated circuit package. The second advantage

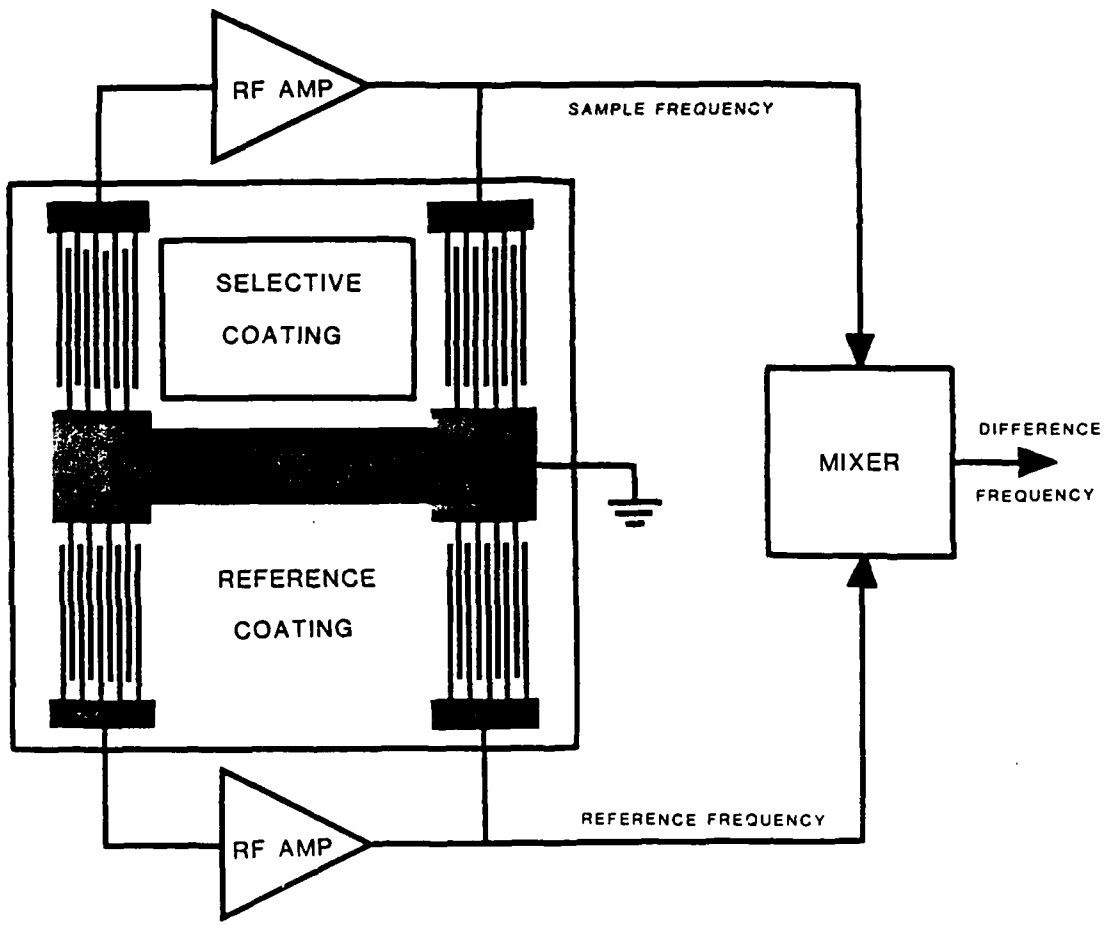

Fig. 3: Dual delay line oscillator system for drift compensation.

is that the reference delay line will experience the same drift due to temperature and pressure effects as the sensor delay line. Thus, very accurate drift compensation can be achieved. It should be mentioned that the temperature coefficient of SAW oscillators made from ST-quartz is quite small (e.g., a few ppm per degree centigrade at 30°C). Nevertheless, when it is necessary to detect trace concentrations of vapor (e.g., ppm and lower) the signal drift from temperature fluctuations can be a problem in a single delay line device. The dual delay line configuration effectively eliminates the temperature and pressure induced drift.

Extending this concept of multiple devices on the same substrate is quite straightforward and will ultimately be limited by the ability to connect the devices to their respective RF amplifiers. Potentially this problem could be solved by micro-fabricating the RF amplifiers and the SAW devices on the same substrate, although such an accomplishment would be non-trivial.

Typical SAW Vapor Sensor Performance

For any sensor it is essential that the baseline noise, drift, response time, linearity and detection limit be known. Operational experience has shown that properly designed SAW delay line oscillators exhibit baseline noise which is less than 1 part in 10^7 of the operating frequency. For example, a 30 MHz SAW delay line oscillator will exhibit short term (i.e., over a period of several minutes) frequency instabilities of less than ± 3 Hz RMS. This number can vary somewhat depending on coating characteristics and RF amplifier layout but offers a reasonably

good rule of thumb. Drift can result from a variety of sources including coating instabilities and temperature or pressure fluctuations. As mentioned previously the dual delay line configuration can minimize the temperature and pressure related drift. Typically encountered coating instabilities include solvent outgassing, coating evaporation, coating poisoning, and coating oxidation. The high sensitivity of the SAW device to mass changes makes detection of these problems quite easy. Drift can also result if an unknown contaminant is capable of interacting with the coating. In well behaved coatings which are stable and thoroughly purged of solvent, the drift rates are low (e.g., 10 Hz/hr at 30 MHz) even in single delay line systems.

Sensor response times are determined by the interaction of the vapor and the coating film. If the interaction is purely physical and diffusion limited, then response times of less than a few seconds can be observed. If the interaction involves chemisorption or is non-reversible, then the sensor may not achieve a steady-state response until the vapor exposure is terminated. Indeed, such an interaction could be useful in dosimetry applications.

Similarly, linearity is determined primarily by the coating film/vapor adsorption isotherm. The response of the SAW device itself to mass changes is often linear up to frequency shifts which are about 0.5% of the operating frequency (which corresponds to a signal-to-noise ratio of about 50,000 to 1).

Detection limits are also heavily dependent upon the properties of the coating film. One can calculate the detection

limit in terms of minimum detectable change in mass per unit area for an arbitrary SAW delay line oscillator if a few assumptions are made. If one assumes that the baseline noise is 1 part in 10^7 of the operating frequency and that the minimum detectable mass change produces a frequency shift which is twice the magnitude of the baseline noise, then by using equation 3 it is possible to conclude:

$$(\Delta W/A)_{\min} = 0.2/k f_0 \quad (4)$$

where $(\Delta W/A)$ is the minimum detectable change in mass per unit area (gms/cm²), k is the SAW material constant (-1.3×10^6 cm² Hz/gm MHz² for YX quartz), and f_0 is the SAW operating frequency (expressed in MHz). Thus, a conservative estimate of the minimum detectable mass loading for a 30 MHz quartz SAW delay line oscillator is 5 nanograms per cm². A 300 MHz device should be able to detect a mass loading of 0.5 nanograms per cm². The absolute detectable mass change depends on the area of the device. A 300 MHz device could easily have an active area of 0.02 cm² which suggests that mass changes of 10^{-11} gms would be detectable.

The detection of vapor relies on a mass change of the coating film when it picks up the desired vapor. Clearly, if the vapor is adsorbed strongly into the coating then relatively low concentrations can result in a measurable mass change. The detection of vapors having concentrations in the low ppm range is quite common. For example, Bryant, Lee and Vetelino (8) have reported that the detection of 10 ppb of SO₂ is possible with their apparatus.

Technical Challenges

It should be apparent that the SAW device is merely a vehicle for measuring subtle changes in the properties of a selective coating when exposed to vapors. The key technical challenge for the successful development of SAW microsensors is to find suitable selective coatings since this element determines selectivity, sensitivity, response time, reversibility and durability of the sensor. The problems of coating development for SAW devices are quite similar to those encountered with bulk wave piezoelectric crystals. One common feature is that the coating must stick to the device's surface. Polymeric coatings which are either functionalized with vapor selective moieties or have selective molecules occluded in the polymeric matrix usually work quite well. High frequency SAW sensors (e.g., 300 MHz) require films which are less than 1000 Å thick to avoid overloading the device. In this thickness range, multilayer films prepared by the Langmuir-Blodgett technique are particularly attractive because of the excellent control of film structure and thickness which is possible. Regardless of the coating technique employed it is essential that the nature of the vapor/coating interaction be adequately characterized both with the target vapor and interferences which can be encountered in the atmosphere to be sampled. The quality of this task is enhanced when the coatings are well characterized chemically and when the vapor/coating interaction can be studied with another method, for example, spectroscopically.

While the operation of the SAW device itself is not presently the main limitation in a SAW vapor sensing system, there are several areas where improvements in the technology are appropriate. From a systems standpoint, the RF electronics required to drive the SAW device occupy a significantly greater volume than the device itself (e.g., 10 cm³ for the electronics vs. 0.1 cm³ for the device). Hybrid microelectronic techniques could probably be used to reduce this disparity. Another technology related area which deserves further work is device packaging. Careful attention should be paid to minimization of connecting wire length between the sensor and the RF electronics.

Significant technical challenges also exist in evaluating the response of the sensors to test vapors. Generation of reasonably precise vapor concentrations in the low ppm range and below is not a simple task. Experience has shown the dynamic systems (e.g., continuously flowing streams of clean air contaminated with a constant trace concentration of the test vapors) are the most reliable. Furthermore, response times can be easily determined by rapidly switching between the sample stream and a clean reference stream with a solenoid valve. Permeation tubes are commercially available for constructing such a test apparatus, but considerable care (e.g., temperature control) is required to guarantee the quantitative accuracy of the system.

Looking toward the future, it seems that SAW vapor sensor systems which are the size of a badge or wristwatch are technologically practical assuming that an appropriate coating

film is available. Realistically, it will probably be necessary to protect the sensor from the environment with a semi-permeable membrane to prevent problems from dust and condensed moisture. In addition, it would be desirable to have a system for modulating the exposure of contaminated air to the sensor. Such a system would allow the unambiguous detection of trace concentrations of vapor without having to worry about long term sensor drift. Finally, it will be important to take advantage of the small size of these devices and build array sensors which will be capable of compensating a non-ideal coating for commonly encountered interferences. Microsensor arrays offer the prospect of truly synergistic sensor/computer systems which may one day rival the human sense of smell and its ability to identify vapor phase chemical species.

Literature Cited

1. White, R.M. Proc. IEEE 1970, 58, 1238.
2. ——— Proc. IEEE 1976, 64, entire issue.
3. Wohltjen, H., Dessy, R., Anal. Chem. 1979, 51, 1458.
4. Wohltjen, H., US Patent 4,312,228, 1982.
5. Fertsch, M.T., Masters Thesis, U.C. Berkeley, CA, 1980.
6. Fertsch, M.T., White, R.M., Muller, R.S., Presented at the Device Research Conference, Ithaca, NY, 1980.
7. Chuang, C.T., White, R.M., Bernstein, J.J., IEEE Elect. Dev. Lett. 1982, EDL-3, 145.
8. Bryant, A., Lee, D.L., Vetelino, J.F., Proc. 1981 Ultrasonics Symp., 1981, IEEE Cat. 81CH1689-9, 1735.
9. D'Amico, A., Palma, A., Verona, E, Appl. Phys. Lett. 1982, 41, 300.
10. Wohltjen, H., NRL Memorandum Report No. 5314, 1984.
11. King, W.H., Jr., Anal. Chem. 1964, 36, 1735.
12. Hlavay, J., Guilbault, G.G., Anal. Chem. 1977, 49, 1890.

END

FILMED

6-85

DTIC