

MICROCOPY RESOLUTION TEST CHART
NATIONAL BUREAU OF STANDARDS-1963-A

PHOTOGRAPH THIS SHEET

II

LEVEL

1

INVENTORY

AD-A154 688

DTIC ACCESSION NUMBER

ME 00186

DOCUMENT IDENTIFICATION

OCT 1978

DISTRIBUTION STATEMENT A

Approved for public release;
Distribution Unlimited

DISTRIBUTION STATEMENT

ACCESSION FOR

NTIS GRA&I

DTIC TAB

UNANNOUNCED

JUSTIFICATION

BY

DISTRIBUTION /

AVAILABILITY CODES

DIST

AVAIL AND/OR SPECIAL

A-1

DISTRIBUTION STAMP



DTIC
SELECTED
JUN 7 1985
S D

DATE ACCESSIONED

DATE RETURNED

85 6 7 155

DATE RECEIVED IN DTIC

REGISTERED OR CERTIFIED NO.

PHOTOGRAPH THIS SHEET AND RETURN TO DTIC-DDAC

AD-A154 688

**MOUSAM RIVER BASIN
SHAPLEIGH, MAINE**

**EMERY MILLS DAM
ME-00186**

**PHASE I INSPECTION REPORT
NATIONAL DAM INSPECTION PROGRAM**



**DEPARTMENT OF THE ARMY
NEW ENGLAND DIVISION, CORPS OF ENGINEERS
WALTHAM, MASS. 02154**

OCTOBER 1978

UNCLASSIFIED

SECURITY CLASSIFICATION OF THIS PAGE (When Data Entered)

REPORT DOCUMENTATION PAGE		READ INSTRUCTIONS BEFORE COMPLETING FORM
1. REPORT NUMBER ME 00186	2. GOVT ACCESSION NO.	3. RECIPIENT'S CATALOG NUMBER
4. TITLE (and Subtitle) Emery Mills Dam NATIONAL PROGRAM FOR INSPECTION OF NON-FEDERAL DAMS		5. TYPE OF REPORT & PERIOD COVERED INSPECTION REPORT
7. AUTHOR(s) U.S. ARMY CORPS OF ENGINEERS NEW ENGLAND DIVISION		6. PERFORMING ORG. REPORT NUMBER
9. PERFORMING ORGANIZATION NAME AND ADDRESS		8. CONTRACT OR GRANT NUMBER(s)
11. CONTROLLING OFFICE NAME AND ADDRESS DEPT. OF THE ARMY, CORPS OF ENGINEERS NEW ENGLAND DIVISION, NEDED 424 TRAPELO ROAD, WALTHAM, MA. 02254		10. PROGRAM ELEMENT, PROJECT, TASK AREA & WORK UNIT NUMBERS
14. MONITORING AGENCY NAME & ADDRESS (if different from Controlling Office)		12. REPORT DATE October 1978
		13. NUMBER OF PAGES 45
		15. SECURITY CLASS. (of this report) UNCLASSIFIED
		15a. DECLASSIFICATION/DOWNGRADING SCHEDULE
16. DISTRIBUTION STATEMENT (of this Report) APPROVAL FOR PUBLIC RELEASE: DISTRIBUTION UNLIMITED		
17. DISTRIBUTION STATEMENT (of the abstract entered in Block 20, if different from Report)		
18. SUPPLEMENTARY NOTES Cover program reads: Phase I Inspection Report, National Dam Inspection Program; however, the official title of the program is: National Program for Inspection of Non-Federal Dams; use cover date for date of report.		
19. KEY WORDS (Continue on reverse side if necessary and identify by block number) DAMS, INSPECTION, DAM SAFETY, Mousam River Basin Shapleigh, Maine Mousam River		
20. ABSTRACT (Continue on reverse side if necessary and identify by block number) The dam is about 250 ft. long with a height of about 26 ft. It is a stone masonry and concrete gravity dam with earth embankment wing walls. The dam is assessed to be in good condition. The dam structure lacks the benefit of routine maintenance. It is intermediate in size with a hazard potential of high.		

EMERY MILLS DAM

ME-00186

MOUSAM RIVER BASIN

SHAPLEIGH, MAINE

PHASE I INSPECTION REPORT
NATIONAL DAM INSPECTION PROGRAM

NATIONAL DAM INSPECTION PROGRAM

PHASE I INSPECTION REPORT

ME-00186

EMERY MILLS DAM

SHAPLEIGH

YORK COUNTY, MAINE

MOUSAM RIVER

September 7, 1978

BRIEF ASSESSMENT

The Emery Mills Dam is a stone masonry and concrete gravity dam with earth embankment wing walls. The dam is about 250 feet long and 26 feet high. The dam is utilized for flood control and recreation.

Based on the visual inspection and its performance history, the Emery Mills Dam is assessed to be in good condition. The dam structure lacks the benefit of routine maintenance, and as outlined in Section 7.3, remedial measures are necessary to assure the long-term safety of the dam.

Based on its intermediate size and high hazard classification, in accordance with the Corps of Engineers' guidelines, the test flood is the Probable Maximum Flood (PMF). The spillway will pass only 25 percent of the test flood and is considered inadequate. The spillway will pass approximately a 50 year flood.

Although no major structural modifications to the dam appear necessary, a thorough evaluation of the hydraulics and hydrology of the dam and watershed should be made. The remedial maintenance items outlined in Section 7.3 should be completed within 12 months after receipt of this report by the owner. Of particular importance are 1) repair of eroded embankment slopes, 2) clearing of trees and brush from the spillway outlet channel, 3) the implementation of a scheme for clearing the trash rack above the outlet gates, and 4) monitor seepage occurring through dam for detection of changes in volume or sediment load. A plan for around-the-clock surveillance during periods of anticipated high runoff and a formal warning system should be developed and implemented.

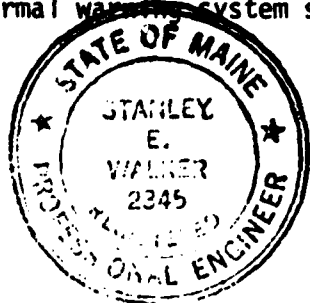

EDWARD C. JORDAN CO., INC.

Stanley E. Walker
Stanley E. Walker, P.E.
Project Manager

This Phase I Inspection Report on Emery Mills Dam has been reviewed by the undersigned Review Board members. In our opinion, the reported findings, conclusions, and recommendations are consistent with the Recommended Guidelines for Safety Inspection of Dams, and with good engineering judgment and practice, and is hereby submitted for approval.

Charles G. Tiersch

CHARLES G. TIERSCH, Chairman
Chief, Foundation and Materials Branch
Engineering Division

Fred J. Ravens, Jr.

FRED J. RAVENS, Jr., Member
Chief, Design Branch
Engineering Division

Saul Cooper

SAUL COOPER, Member
Chief, Water Control Branch
Engineering Division

APPROVAL RECOMMENDED:

Joe B. Fryar

JOE B. FRYAR
Chief, Engineering Division

PREFACE

This report is prepared under guidance contained in the Recommended Guidelines for Safety Inspection of Dams, for Phase I investigations. Copies of these guidelines may be obtained from the Office of Chief of Engineers, Washington, D.C. 20314. The purpose of a Phase I investigation is to identify expeditiously those dams which may pose hazards to human life or property. The assessment of the general condition of the dam is based upon available data and visual inspections. Detailed investigation, and analyses involving topographic mapping, subsurface investigations, testing, and detailed computational evaluations are beyond the scope of a Phase I investigation; however, the investigation is intended to identify any need for such studies.

In reviewing this report, it should be realized that the reported condition of the dam is based on observations of field conditions at the time of inspection along with data available to the inspection team. In cases where the reservoir was lowered or drained prior to inspection, such action, while improving the stability and safety of the dam, removes the normal load on the structure and may obscure certain conditions which might otherwise be detectable if inspected under the normal operating environment of the structure.

It is important to note that the condition of a dam depends on numerous and constantly changing internal and external conditions, and is evolutionary in nature. It would be incorrect to assume that the present condition of the dam will continue to represent the condition of the dam at some point in the future. Only through continued care and inspection can there be any chance that unsafe conditions be detected.

Phase I inspections are not intended to provide detailed hydrologic and hydraulic analyses. In accordance with the established guidelines, the spillway test flood is based on the estimated "Probable Maximum Flood" for the region (greatest reasonably possible storm runoff), or fractions thereof. Because of the magnitude and rarity of such a storm event, a finding that a spillway will not pass the test flood should not be interpreted as necessarily posing a highly inadequate condition. The test flood provides a measure of relative spillway capacity and serves as an aide in determining the need for more detailed hydrologic and hydraulic studies, considering the size of the dam, its general condition and the downstream damage potential.

TABLE OF CONTENTS

	<u>PAGE</u>
LETTER OF TRANSMITTAL	
BRIEF ASSESSMENT.....	i
REVIEW BOARD SIGNATURE SHEET.....	ii
PREFACE.....	iii
TABLE OF CONTENTS.....	iv
OVERVIEW PHOTOGRAPH.....	vi
LOCATION MAP.....	vii

SECTION 1 - PROJECT INFORMATION

1.1 GENERAL.....	1
1.2 DESCRIPTION OF PROJECT.....	1
1.3 PERTINENT DATA.....	3

SECTION 2 - PROJECT INFORMATION

2.1 DESIGN.....	7
2.2 CONSTRUCTION.....	7
2.3 OPERATION.....	7
2.4 EVALUATION.....	7

SECTION 3 - VISUAL INSPECTION

3.1 FINDINGS.....	8
3.2 EVALUATION.....	9

TABLE OF CONTENTS (continued)

SECTION 4 - OPERATING PROCEDURES

4.1 PROCEDURES.....	10
4.2 MAINTENANCE OF DAMS.....	10
4.3 MAINTENANCE OF OPERATING FACILITIES.....	10
4.4 DESCRIPTION OF ANY WARNING SYSTEM IN EFFECT.....	10
4.5 EVALUATION.....	10

SECTION 5 - HYDRAULIC/HYDROLOGIC

5.1 EVALUATION OF FEATURES.....	11
---------------------------------	----

SECTION 6 - STRUCTURAL STABILITY

6.1 EVALUATION OF STRUCTURAL STABILITY.....	13
---	----

SECTION 7 - ASSESSMENT, RECOMMENDATIONS AND REMEDIAL MEASURES

7.1 DAM ASSESSMENT.....	14
7.2 RECOMMENDATIONS.....	15
7.3 REMEDIAL MEASURES.....	15
7.4 ALTERNATIVES.....	16

APPENDICES

A FIELD INSPECTION NOTES	
B ENGINEERING DATA	
C PHOTOGRAPHS	
D HYDROLOGIC AND HYDRAULIC COMPUTATIONS	
E INFORMATION AS CONTAINED IN THE NATIONAL INVENTORY OF DAMS	



OVERVIEW

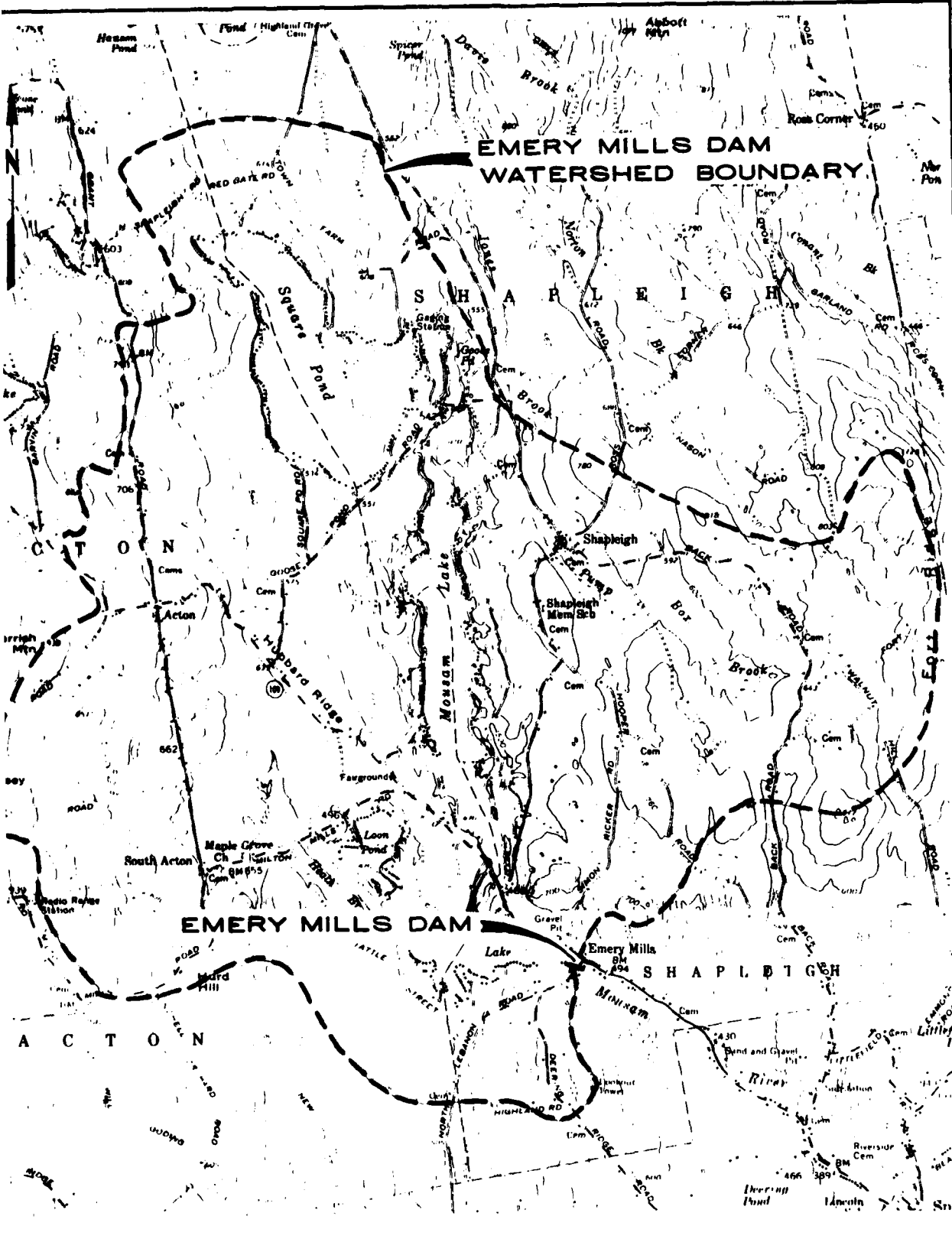

EDWARD C. JORDAN CO., INC. PORTLAND, MAINE	U.S. ARMY ENGINEER DISTRICT OFFICE CONCORD, MASS.
NATIONAL PROGRAM OF INSPECTION OF NON-FED DAMS	
EMERY MILLS DAM LOCATION MAP	
MOUSAM RIVER MAINE	
REVISED OCTOBER 1978	

PHASE I INSPECTION REPORT

EMERY MILLS DAM

SECTION 1

PROJECT INFORMATION

1.1 GENERAL

a. Authority. Public Law 92-367, August 8, 1972, authorized the Secretary of the Army, through the Corps of Engineers, to initiate a National Program of Dam Inspection throughout the United States. The New England Division of the Corps of Engineers has been assigned the responsibility of supervising the inspection of dams within the New England Region. Edward C. Jordan Co., Inc. has been retained by the New England Division to inspect and report on selected dams in the State of Maine. Authorization and notice to proceed were issued to Edward C. Jordan Co., Inc. under a letter of June 20, 1978 from Ralph T. Garver, Colonel, Corps of Engineers. Contract No. DACW33-78-C-0349 has been assigned by the Corps of Engineers for this work.

b. Purpose

- (1) To perform technical inspection and evaluation of non-Federal dams to identify conditions which threaten the public safety and thus permit correction in a timely manner by non-Federal interests.
- (2) To encourage and prepare the states to initiate quickly effective dam safety programs for non-Federal dams.
- (3) To update, verify and complete the National Inventory of Dams.

1.2 DESCRIPTION OF PROJECT

a. Location. The Emery Mills Dam is located in the town of Shapleigh, Maine. It is located approximately 3 1/2 miles upstream of the built-up portion of the town of Sanford. N 43° 29.6' W 70° 50.9'.

7.2 RECOMMENDATIONS

Since the spillway capacity is considered inadequate, a qualified engineer should make a further evaluation of the hydrology and hydraulics of the watershed and dam and design additional spillway capacity as may be warranted.

A qualified engineer should inspect the downstream slope of the dam below the spillway after it has been cleared of brush, trees, and debris to determine if there could be problems with erosion caused by spillway flows, and, if so, to design appropriate remedial measures.

7.3 REMEDIAL MEASURES

- a. Operating and Maintenance Procedures. A program of regular inspection and maintenance should be implemented and a record of activities should be kept. The following operating and maintenance procedures should be implemented within 12 months after receipt of this report by the owner:
1. Repair and stabilize with riprap the areas of the upstream slopes of the embankments where erosion has occurred.
 2. Cut all brush and trees from the downstream masonry face of the dam and maintain this face clear of brush. Do not, however, attempt to remove stumps.
 3. Clear all brush, trees, and debris from the area directly below the spillways, for a distance of at least 100 feet.
 4. Clean the debris from the trash rack above the outlet gates and provide a means for routine removal of accumulated debris from the trash rack.
 5. Repair areas of spalled concrete.
 6. Provide around-the-clock surveillance during periods of anticipated high runoff.
 7. Develop a formal warning system and implement its use in the event of an emergency.

SECTION 7

ASSESSMENT, RECOMMENDATIONS AND REMEDIAL MEASURES

7.1 DAM ASSESSMENT

- a. Condition. Based on the visual inspection and performance history of the Emery Mills Dam, it is assessed to be in good condition. The spillways of the dam will pass approximately a 50 year flood discharge. The probable maximum flood (PMF) peak flow at the dam has been calculated to be 16,680 cfs. Due to surcharge storage in Mousam Lake, the dam has to pass a reduced peak flow of about 8660 cfs. To pass this flow the structure would be overtopped by approximately 4.2 feet. The spillway capacity is about 25 percent of the adjusted PMF.

The inspection of the facility identified the following major items of concern: 1) the erosion occurring on the upstream slopes of the embankment portions of the dam, 2) the potential clogging of the downstream channel in the trees below the spillways, 3) the potential clogging of the trash rack above the outlet gate, 4) the inadequate spillway capacity, and 5) seepage coming from lower portions of the downstream face of the dam below the spillway and controlled outlet sections.

- b. Adequacy of Information. The information available is such that the assessment of the condition of the dam must be based primarily on the visual inspection, the past operational performance of the dam, and engineering judgment.
- c. Urgency. The recommendations outlined in 7.2 below should be implemented within 24 months after receipt of this report by the owner. The remedial maintenance of the facilities should be implemented within 12 months.
- d. Need for Additional Investigation. Additional investigation is not considered necessary for the current assessment.

SECTION 6
STRUCTURAL STABILITY

6.1 EVALUATION OF STRUCTURAL STABILITY

- a. Visual Observations. Based on the visual observations the dam appears to be in good structural condition. Seepage was observed to be coming from the masonry on the lower portion of the downstream face of the spillway and controlled outlet sections of the dam. However, this seepage does not appear to have a detrimental affect on the structure. Erosion observed on the upstream faces of the embankment portions of the dam, however, present a concern regarding the long-term structural stability of the dam.
- b. Design and Construction Data. No data concerning original design or construction of the Emery Mills Dam was located in this investigation.
- c. Operating Records. None available.
- d. Post Construction Changes. No major repairs or alterations are known to have been made on the dam. No settlement or horizontal movement is apparent in the dam structure. The only post construction changes noted were some erosion of upstream faces of the embankment portions of the dam, some spalling of the concrete in the area of the outlet structure, tree growth on and below the dam, and seepage coming from the lower portion of the downstream face of the dam below the spillway and controlled outlet sections.
- e. Seismic Stability. The dam is located in Seismic Zone No. 2 and in accordance with recommended Phase I guidelines, does not warrant seismic analysis.

emergency spillways. Below the spillways of the dam there were trees and bushes growing and large amounts of debris had accumulated. The route for flows from the emergency spillways is through an area of trees and debris and into a rock lined channel at the controlled gate outlet.

e. Test Flood Analysis. Since it is classified as having a high hazard potential, the Emery Mills Dam was analyzed for passing a test flood equal to the probable maximum flood (PMF). The PMF has been calculated to be 16,680 cfs according to COE's "Preliminary Guidance for Estimating Probable Maximum Discharges in Phase I Dam Safety Investigations." Consideration of the effect of surcharge storage (according to the same COE reference) reduces the PMF to 8660 cfs. The PMF would overtop the dam by approximately 4.2 feet. The total capacity of the dam at full spillway is 2200 cfs, which is about 25 percent of the adjusted PMF.

f. Dam Failure Analysis. The hazard potential was determined by analyzing downstream dam failure hydrographs according to rule of thumb methods as described in an attachment to ETL 1100-2-234. The failure analysis criteria sets the pool elevation at full spillway capacity. The wave height just downstream of the dam would be about 25 feet. The wave height would be reduced to a height of about 17 feet at a location 2000 feet downstream from the dam. At the Route 109 bridge about 6500 feet downstream from the dam, the wave height would be about 17 feet. Further downstream, at the Mill Street Dam in Sanford, the wave height would be about 2.6 feet above the earth embankment east wing wall, and there would be damage to the factory buildings near the dam. If there were employees in the factory downstream of the Mill Street Dam at the time of a failure of the Emery Mills Dam, there would be a chance that many lives would be lost in the factory. Thus, the Emery Mills Dam is classified as having a high hazard potential.

SECTION 5

HYDRAULIC/HYDROLOGIC

5.1 EVALUATION OF FEATURES

- a. General. The Emery Mills Dam is a stone masonry and concrete gravity structure with earth wing walls. Mousam Lake forms the headwaters of the Mousam River at the dam. The lake has an area of about 880 acres at normal pond elevation (481). Between normal pond elevation and the top of the dam there is 6.5 feet of available surcharge storage.
- b. Design Data. Design data was not available for the Emery Mills Dam.
- c. Experience Data. Published hydrologic and hydraulic data appears to be almost entirely lacking for Emery Mills Dam. There is a USGS gage on the Mousam River near West Kennebunk (drainage area 105 square miles), but the gage is too far from the Emery Mills Dam (drainage area 29.3 square miles) to be of any real significance. Also the USGS, in Paper No. 1671, published hydrologic data for the Emery Mills Dam. Presented below is a table of estimated flood flows presented in the paper.

<u>RECURRENCE INTERVAL, (Years)</u>	<u>FLOW, (cfs)</u>
1	570
10	1200
20	1590
50	2280
100	2900

No record of lake levels could be located. The water surface elevation and discharge of the maximum flood is unknown.

- d. Visual Observations. The discharge at the Emery Mills Dam is controlled by a gated outlet and two

SECTION 4
OPERATING PROCEDURES

4.1 PROCEDURES

The gates at the dam are operated to maintain a recreation pond level in Mousam Lake and to maintain sufficient flow in the Mousam River. The gates are operated also to pass heavy runoff such as spring snow melt. The gate house is secured with a padlock between operations and appears to be adequately protected from vandals.

4.2 MAINTENANCE OF DAM

No record of maintenance was available for the Emery Mills Dam. No major repairs are known to have been made on the dam. It was noted during the visual inspection that the dam lacks the benefit of routine maintenance and that the upstream slopes of the earth embankments have undergone erosion and displacement of the riprap and that the downstream face has not been cleared of trees or brush. Also the channel below the spillways of the dam has not been cleared of trees or brush.

4.3 MAINTENANCE OF OPERATING FACILITIES

No record of maintenance of the operating facilities of the dam was found to be available. The operating equipment was found to be in good repair and appeared to be maintained regularly.

4.4 DESCRIPTION OF ANY WARNING SYSTEM IN EFFECT

None in effect.

4.5 EVALUATION

Although the Emery Mills Dam appears to be in reasonably good condition no regular maintenance program is in effect. As outlined in Section 7, some maintenance of the facility is necessary. No warning system for either high water or structural distress is in effect at the dam.

(2) Hydraulics - At the time of the visual inspection, the lake level was at about elevation 480, three feet below the lower of two emergency spillways. Discharge from the dam was through the gate works. Below the spillways of the dam there were trees and bushes growing and large amounts of debris had accumulated.

c. Appurtenant Structures. The controlled outlet gates at the dam consist of two steel gates with screw lift stems. The hoisting equipment is operated manually by a vertical rack and gear. The gate works were found to be in good mechanical order. The gate works are contained within a masonry gate house which is locked and adequately protected from vandals. The trash rack immediately above the outlet gates was found to be heavily littered with debris. It was noted that the clearing of the trash rack would be difficult due to its location in the inlet structure.

d. Reservoir Area. The reservoir consists of Mousam Lake which is about 880 acres in area. There are many cottages along the shoreline. Little sediment was observed in the lake.

e. Downstream Channel. The channel downstream of the control gate outlet has vertical stone side walls and is clear and unobstructed. The outlet channel from the spillways has grown up with trees and is littered with debris.

3.2 EVALUATION

Based on the visual inspection the dam appears to be in good structural and mechanical condition. The dam does, however, appear to lack the benefit of routine maintenance. As outlined in Section 7, maintenance of the dam is necessary.

SECTION 3
VISUAL INSPECTION

3.1 FINDINGS

- a. General. The Emery Mills Dam is located in a shallow bedrock valley. It appears to be founded entirely on bedrock. The dam shows no signs of serious distress.
- b. Dam.
- (1) Structural - The dam is constructed of mortar laid cut stone masonry and concrete. See plan, profile, and cross-sections in Appendix B. The dam appears to be in good structural condition, however it appears to lack the benefit of routine maintenance. See Appendix A for detailed inspection findings. The inspection of the Emery Mills Dam resulted in the following major findings:
- (a) The dam structure appears to be true to line and grade; no horizontal or vertical movement was observed.
- (b) Some spalling of the concrete surfaces in the areas of the controlled outlet gatehouse has occurred. See photograph 3.
- (c) Tree growth and brush growth has occurred in the masonry of the downstream face of the dam.
- (d) Some displacement of the riprap and some erosion has occurred on the upstream face of the north embankment wing wall. Some erosion has also occurred on the south embankment wing wall on the upstream face.
- (e) Seepage was observed coming from the lower portion of the downstream face of the dam below the spillway and controlled outlet sections. This seepage was found to be clear and no erosion was apparent.

SECTION 2
ENGINEERING DATA

2.1 DESIGN

This investigation disclosed no available design data.

2.2 CONSTRUCTION

No information was found to be available regarding construction of the Emery Mills Dam.

2.3 OPERATION

The gates at the Emery Mills Dam are operated to maintain a recreation pond level in Mousam Lake and to maintain a flow in the Mousam River.

2.4 EVALUATION

- a. Availability. No data is available regarding design or construction of the facilities.
- b. Adequacy. The lack of in-depth engineering data did not allow for a definitive review. Therefore the adequacy of this dam could not be assessed from the standpoint of reviewing design and construction data, but is based primarily on visual inspection, performance history and engineering judgment.
- c. Validity. Not applicable.

Downstream Channel - The gates discharge flows into a rock walled channel which is about 17 feet wide and extends to a bridge 250 feet below the dam. See photograph 6. The flows from the two spillways discharge below the dam into an area grown up with trees and bushes and littered with debris.

j. Regulating Outlets.

Invert - The invert elevation is about 463 feet above MSL.

Size - 10 feet wide, 6 feet high

Description - The regulated outlet sluiceway is constructed of stone masonry with an arched roof. See overview photograph.

Control Mechanism - The regulated outlet is closed by two steel gates. The gates are a vertical lift type and have a manually operated lifting mechanism. See photographs 3 and 4.

Other - Not applicable.

g. Dam

Type - The dam is stone masonry and concrete gravity dam with earth embankment wing walls.

Length - The dam has an overall length of approximately 250 feet.

Height - The top of dam is approximately 26 feet above the streambed.

Top Width - See cross-sections in Appendix B.

Side Slopes - See cross-sections in Appendix B.

Zoning - The southerly embankment appears to be a homogeneous fill. The northerly embankment has a downstream stone masonry section. See cross-sections.

Impervious Core - Not applicable.

Cut-off - The stone masonry portions of the dam form a cut-off wall.

Grout Curtain - Not applicable.

Other - Not applicable.

h. Diversion and Regulating Tunnel. Not applicable.

i. Spillway.

Type - There are 2 emergency spillways side by side. They have configurations as shown on the cross-sections in Appendix B.

Length - The spillways are 25.4 feet and 34.0 feet in length.

Crest Elevation - The crest elevations are taken as 483 and 484 (feet above MSL).

Gates - None

Upstream Channel - small cove about 250 feet wide leading from Mousam Lake.

ITEM	ELEVATION ABOVE MSL
Streambed at Centerline of Dam	463
Maximum Tailwater	Unknown
Upstream Portal Invert Diversion Tunnel	N/A
Recreation Pool (Normal Pool)	481
Full Flood Control Pool	487.5
Spillway Crest (ungated) No. 1	483
Spillway Crest (ungated) No. 2	484
Design surcharge	Unknown
Top of Dam	487.5
Test Flood (PMF) Design Surcharge	491.7

d. Reservoir. The lengths of the maximum/flood control pool (elevation 487.5) and the recreation pool were estimated from USGS maps. The lengths are shown below.

ITEM	LENGTH (miles)
Maximum/Flood Control Pool	4.9
Recreation Pool	4.9

e. Storage

ITEM	STORAGE (acre-feet)
Recreation Pool	27,850
Flood Control/Top of Dam	37,900
Spillway Crest Pool (@ Elevation 483)	30,950
Test Flood (PMF) Pool	55,400

f. Reservoir Surface. The following are estimated surface areas for Mousam Lake.

ITEM	SURFACE AREA (acres)
Top of Dam/Maximum Pool	1380
Recreation Pool	880

1.3 PERTINENT DATA

- a. Drainage Areas. The drainage area above the Emery Mills Dam is approximately 29.3 square miles and lies in portions of Shapleigh and Acton. About 10 percent of the entire drainage area is storage at Mousam Lake, Square Pond, Goose Pond, and Loon Pond. The watershed has relatively flat topography with a few hills varying in elevation from about 470 feet to 1300 feet.
- b. Discharge at Damsite. There are 2 vertical lift gates which are each 4 feet in width by 3 feet in height. The invert elevation (MSL) is approximately 463. The following are pertinent discharges:
- (1) Maximum flood at damsite is unknown.
 - (2) Ungated spillway capacity at top of dam is about 1550 cfs at elevation 487.5.
 - (3) Ungated spillway capacity (total spillway capacity) at test flood (PMF) elevation is about 5530 cfs at elevation 491.7.
 - (4) Gated spillway capacity is not applicable.
 - (5) Total project discharge at test flood (PMF) is 8660 cfs at elevation 491.7.
- c. Elevation. Survey data collected at the Emery Mills Dam was referenced to a temporary benchmark. The following elevations were later referenced to USGS mean sea level datum by assuming that the normal pond elevation on the USGS map (elevation 481) is equal to an elevation 2 feet below the lower emergency spillway elevation. This appears to be a reasonable estimate of normal pool elevation based on visual observations at the dam.

- b. Description of Dam and Appurtenances. The dam is a stone masonry and concrete gravity structure with earth wing walls. The southerly earth embankment is approximately 30 feet in length. The stone masonry and concrete section of the dam is approximately 110 feet in length and the northerly earth embankment wing wall is approximately 110 feet in length. The dam is approximately 26 feet high.
- c. Size Classification. Based on a storage capacity of 27,850 acre-feet, the Emery Mills Dam is classified as an intermediate sized dam (greater than 1000 acre-feet and less than 50,000 acre-feet).
- d. Hazard Classification. In the event of failure of the Emery Mills Dam, there would be damage to structures and property at least as far downstream as the Mill Street Dam Site in Sanford. Thus, the Emery Mills Dam is classified as having a high hazard potential.
- e. Ownership. The owner of the dam is the town of Sanford, Municipal Building, Sanford, Maine. The dam was built and previously owned by Sanford Mills. Due to the close proximity of the operator this dam is considered a manned project.
- f. Operator - Richard Gallant
Emery Mills
Shapleigh, Maine
Phone (207) 636-1857
- g. Purpose of Dam. The purpose of the dam is recreation.
- h. Design and Construction History. A dam was constructed at the site prior to 1886. About 1900 the existing dam was built and no major changes have been made since. No design information was found to be available.
- i. Normal Operating Procedures. The gates are operated at the Emery Mills Dam to maintain a recreational pond level in Mousam Lake. No power is derived from the dams downstream, therefore Mousam Lake is not used as a power storage reservoir.

8. Have inspections of the dam made by qualified engineers once every two years.
9. Monitor the seepage coming from the downstream face of the dam for the detection of changes in volume or the development of sediment in the flow.

7.4 ALTERNATIVES

Not applicable.

VISUAL INSPECTION CHECKLIST
PARTY ORGANIZATION

PROJECT Emery Mills Dam-Safety Inspection

DATE 9/7/78

TIME PM

WEATHER Sunny Warm

W.S. ELEV. 480 U.S. 463 DN.S.

PARTY:

- | | |
|-------------------------|-----------|
| 1. <u>Brian Bisson</u> | 6. _____ |
| 2. <u>Stephen Cole</u> | 7. _____ |
| 3. <u>Ernest Jurick</u> | 8. _____ |
| 4. <u>John Kimble</u> | 9. _____ |
| 5. <u>Henry Oatley</u> | 10. _____ |

PROJECT FEATURE	INSPECTED BY	REMARKS
1. <u>Hydraulics/Hydrology</u>	<u>Bisson</u>	
2. <u>Geotechnical</u>	<u>Cole</u>	
3. <u>Structural</u>	<u>Cole, Oatley</u>	
4. <u>Photography</u>	<u>Jurick</u>	
5. <u>Survey</u>	<u>Kimble</u>	
6. _____		
7. _____		
8. _____		
9. _____		
10. _____		

NOTE: See Supplementary Inspection Notes Following Checklist

INSPECTION CHECKLIST

PROJECT <u>Emery Mills Dam</u>	DATE <u>9/7/78</u>
PROJECT FEATURE <u>Embankments</u>	NAME <u>Cole</u>
DISCIPLINE <u>Geotechnical</u>	NAME _____

AREA EVALUATED	CONDITIONS
----------------	------------

DAM EMBANKMENT

Crest Elevation	487.5
Current Pool Elevation	481
Maximum Impoundment to Date	Unknown
Surface Cracks	None
Pavement Condition	Turf, Trees and Brush
Movement or Settlement of Crest	None
Lateral Movement	None
Vertical Alignment	Good
Horizontal Alignment	Good
Condition at Abutment and at Concrete Structures	Good
Indications of Movement of Structural Items on Slopes	None evident
Trespassing on Slopes	None
Sloughing or Erosion of Slopes or Abutments	Erosion evident at and above water line, upstream slopes
Vegetation	Trees & brush, some turf
Rock Slope Protection - Riprap Failures	North embankment, some erosion due to failure

INSPECTION CHECKLIST

PROJECT Emery Mills Dam

DATE 9/7/78

PROJECT FEATURE Embankments

NAME Cole

DISCIPLINE Geotechnical

NAME _____

AREA EVALUATED	CONDITIONS
----------------	------------

DAM EMBANKMENT (cont.)

Unusual Embankment or Downstream
Seepage

5 to 10 gpm from north side
of outlet channel training wall

Piping or Boils

None

Foundation Drainage Features

None found

Toe Drains

None found

Instrumentation System

None

INSPECTION CHECKLIST

PROJECT <u>Emery Mills Dam</u>	DATE <u>9/7/78</u>
PROJECT FEATURE <u>Intake Channel/Structure</u>	NAME <u>Cole</u>
DISCIPLINE <u>Structural, Geotechnical Hydraulics</u>	NAME <u>Oatley Bisson</u>

AREA EVALUATED

CONDITION

OUTLET WORKS - INTAKE CHANNEL AND
INTAKE STRUCTURE

- | | |
|------------------------------|---|
| a. Approach Channel | |
| Slope Conditions | Good |
| Bottom Conditions | Clear, no obstructions |
| Rock Slides or Falls | None evident |
| Log Boom | None |
| Debris | Some in trash rack |
| Condition of Concrete Lining | None |
| Drains or Weep Holes | None |
| b. Intake Structure | |
| Condition of Concrete | Fair - some spall |
| Stop Logs and Slots | None |
| Debris Screen | Heavily loaded with debris - no
method apparent for clearing |

INSPECTION CHECKLIST

PROJECT Emery Mills Dam DATE 9/7/78
 PROJECT FEATURE Control Tower NAME Cole
 DISCIPLINE Structural, Geotechnical NAME Oatley
Hydraulics Bisson

AREA EVALUATED	CONDITION
----------------	-----------

OUTLET WORKS - CONTROL TOWER

a. Masonry and Structural

General Condition	Fair
Condition of Joints	Good
Spalling	Some - training walls
Visible Reinforcing	None
Rusting or Staining of Concrete	None
Any Seepage or Efflorescence	None
Joint Alignment	Good
Unusual Seepage or Leaks in Gate Chamber	None
Cracks	No structural cracking apparent
Rusting or Corrosion of Steel	None

b. Mechanical and Electrical

Air Vents	N/A
Float Wells	N/A
Gate Hoist	Good condition
Elevator	N/A
Hydraulic System	N/A

INSPECTION CHECKLIST

PROJECT Emery Mills Dam DATE 9/7/78
PROJECT FEATURE Control Tower NAME Cole
DISCIPLINE Structural, Geotechnical NAME Oatley
Hydraulics Bisson

AREA EVALUATED

CONDITION

OUTLET WORKS - CONTROL TOWER (cont.)

Service Gates	Gates and stems appear good
Emergency Gates	
Lightning Protection System	N/A
Emergency Power System	N/A
Wiring and Lighting System	None

INSPECTION CHECKLIST

PROJECT Emery Mills Dam DATE 9/7/78
 PROJECT FEATURE Conduit NAME Cole
 DISCIPLINE Structural, Geotechnical NAME Oatley
Hydraulics Bisson

AREA EVALUATED	CONDITION
----------------	-----------

OUTLET WORKS - TRANSITION AND CONDUIT

General Condition of Stone Masonry	Good
Rust or Staining on Stone Masonry	None
Spalling	None
Erosion or Cavitation	None
Cracking	None
Alignment of Monoliths	N/A
Alignment of Joints	Good
Numbering of Monoliths	N/A

PERIODIC INSPECTION CHECKLIST

PROJECT Emery Mills Dam DATE 9/7/78
 PROJECT FEATURE Outlet Structure/Channel NAME Cole
 DISCIPLINE Structural, Geotechnical NAME Oatley
Hydraulics Bisson

AREA EVALUATED

CONDITION

OUTLET WORKS - OUTLET STRUCTURE AND
OUTLET CHANNEL

General Condition of Stone Masonry	Good
Rust or Staining	Some staining of masonry
Spalling	None
Erosion or Cavitation	None
Visible Reinforcing	None
Any Seepage or Efflorescence	Some seepage through downstream face
Condition at Joints	Good
Drain holes	None
Channel	Masonry wall, bedrock and cobble floor - good condition
Loose Rock or Trees Overhanging Channel	Some trees adjacent to channel
Condition of Discharge Channel	Good, clear, unobstructed

INSPECTION CHECKLIST

PROJECT <u>Emery Mills Dam</u>	DATE <u>9/7/78</u>
PROJECT FEATURE <u>Spillway</u>	NAME <u>Cole</u>
DISCIPLINE <u>Structural, Geotechnical Hydraulics</u>	NAME <u>Oatley Bisson</u>

AREA EVALUATED

CONDITION

OUTLET WORKS - SPILLWAY WEIR, APPROACH
AND DISCHARGE CHANNELS

a. Approach Channel

General Condition	Good - clear
Loose Rock Overhanging Channel	None
Trees Overhanging Channel	None
Floor of Approach Channel	Clear

b. Weir and Training Walls

General Condition of Concrete and Masonry	Good
Rust or Staining	None
Spalling	None
Any Visible Reinforcing	None
Any Seepage or Efflorescence	Seepage from downstream face
Drain Holes	None

c. Discharge Channel

General Condition	Poor
Loose Rock Overhanging Channel	None
Trees Overhanging Channel	Trees and brush in channel
Floor of Channel	Forest duff over bedrock
Other Obstructions	Debris among trees from previous flow over spillway

INSPECTION CHECKLIST

PROJECT Emery Mills Dam DATE 9/7/78
 PROJECT FEATURE Service Bridge NAME --
 DISCIPLINE -- NAME --

AREA EVALUATED

CONDITION

OUTLET WORKS - SERVICE BRIDGE

a. Super Structure NONE AT DAM

Bearings

Anchor Bolts

Bridge Seat

Longitudinal Members

Under Side of Deck

Secondary Bracing

Deck

Drainage System

Railings

Expansion Joints

Paint

b. Abutment & Piers

General Condition of Concrete

Alignment of Abutment

Approach to Bridge

Condition of Seat & Backwall

SUPPLEMENTARY INSPECTION NOTES

1. CONCRETE AND STONE MASONRY STRUCTURE

- a. Concrete Surfaces - the concrete surfaces on the dam are generally in good condition. Some spalling has occurred along the north wing wall of the spillway.

Stone Masonry Surfaces - the south wing wall of the spillway and south abutment of the dam are constructed of dry laid stone masonry. This masonry appears to be tight and in good condition. The southerly portion of the spillway and the entire downstream face of the dam are constructed of mortar laid stone masonry. The masonry is tight. Some lime staining has occurred, and some of the joints are cracked, but the mortar appears to be in good condition. Tree and brush growth has occurred in the downstream masonry face of the dam. Just north of the controlled outlet is a section of the upstream face which is paved with granite cobble stones placed in mortar. This area shows signs of spalling, cracking and displacement of the mortar and stone.

- b. Structural Cracking - no cracking of concrete or stone masonry elements of the dam were observed which appears related to structural distress.
- c. Movement - no movement, horizontal or vertical, is apparent in the structure.
- d. Junctions - the junctions of the dam, from the south abutment to the spillway, the north end of the spillway to the controlled outlet, and from controlled outlet to the north wing wall, all show no signs of movement or distress.
- e. Drains - no formal drainage system is known to exist in the dam and none was observed.
- f. Water Passages - the controlled outlet sluiceway consists of cut stone masonry which is mortar laid. No obstructions were observed in the outlet sluiceway and no erosion of the surfaces is ap-

parent. The spillway section of the dam consists of a stone masonry portion and a concrete portion. Both sections show no signs of erosion and are in good condition. See photograph 1.

- g. Seepage or Leakage - seepage was observed from the masonry along the lower portion of the downstream face of the spillway and of the lower portion of the downstream face of the gate house section of the dam. Seepage was also observed coming from the north side of the training wall at the outlet channel. The seepage below the dam was estimated to be approximately 25 to 40 gpm total. The seepage was clear and apparently causing no erosion.
- h. Monolith Joints - the dam generally consists of mortar laid stone masonry with a concrete cap and upstream face. The masonry joints show signs of some cracking, however the mortar is good and the masonry is tight. The visible construction joints in the concrete surface were found to be tight.
- i. Foundation - based on observed bedrock outcrops near the north and south abutments of the dam, it appears that the Emery Mills Dam is founded on bedrock. No undermining or distress was observed.
- j. Abutments - the abutments of the dam appeared to be both founded on bedrock; no sign of distress was observed at either abutment.

2. EMBANKMENT STRUCTURES

A short embankment section exists south of the spillway of the dam and a substantial embankment exists north of the gate house of the dam to the north abutment. This northerly embankment is retained on the downstream side by a stone masonry wall.

- a. Settlement - the embankment sections of the dam appear to be in good condition. No evidence of settlement or depressions was observed.
- b. Slope Stability - the south embankment has moderate slopes, 3 on 1, and has a turf or grass surface. The north embankment has an upstream slope of approximately 3 on 1 and is retained on the downstream side by a stone masonry wall which is true to line and grade.

- c. Seepage - no seepage was observed downstream of the embankment portions of the dam.
- d. Drainage Systems - no drainage system is known to exist in the embankment portions of the dam and none was observed.
- e. Slope Protection - the southerly embankment has a grassed surface. Some erosion has occurred on the upstream face of the embankment at or a little above the water level in the pond.

The north embankment has a poorly maintained riprap surface on the upstream face. The upstream face is covered with brush and small trees. Some erosion has occurred on this slope. The erosion appears to have been caused by wave action and ice conditions.

3. SPILLWAY STRUCTURES

The spillway at the dam consists of two sections, a lower section which has a stone masonry surface and a higher section which is a concrete surface. See plan and cross-sections in Appendix B and photograph 1.

- a. Control Gates and Operating Machinery - the spillway has no control or operating gates.
- b. Unlined Saddle Spillways - not applicable.
- c. Approach and Outlet Channels - the approach channel to the spillway is clear and unobstructed. See photograph 2. The outlet channel from the spillway has grown up with trees and is littered with debris and logs. The channel downstream of the control gate outlet has vertical stone side walls and is clear and unobstructed. See photograph 5.
- d. Stilling Basin - there is no feature for preventing erosion downstream of the spillway, however no serious erosion was observed.

4. OUTLET WORKS

The outlet works consist of two vertical lift gates which are manually operated.

ECT

COMP BY

JOB NO.

JHF

20282 08

CHK BY

DATE

BTB

10/4/78

Mausam River Profile

Location	Station	Elevation (approx.)
Washington Street Bridge	0+00	280
Winter Street Bridge	8+00	282
River Street Bridge	43+00	292
Pleasant Street Bridge	65+50	299
River Street Dam	70+50	~300 D/S
Conford & Eastern R.R. Bridge	94+90	309
Bridge Street Bridge	123+20	320
Mill Street Bridge	129+50	340
Mill Street Dam	131+50	~340 D/S
Back Road Bridge	201+50	380
Ste. 11/109 Bridge	256+50	430
J. Lebanon Road Bridge	321+50	480
Emergy Mills Dam	324+00	~480 D/S

APPENDIX D

HYDROLOGIC AND HYDRAULIC COMPUTATIONS

Attached to this section are the hydrologic and hydraulic computations for the Emery Mills Dam. The drainage area tributary to the Emery Mills Dam is outlined on the location map found in the front of this report.

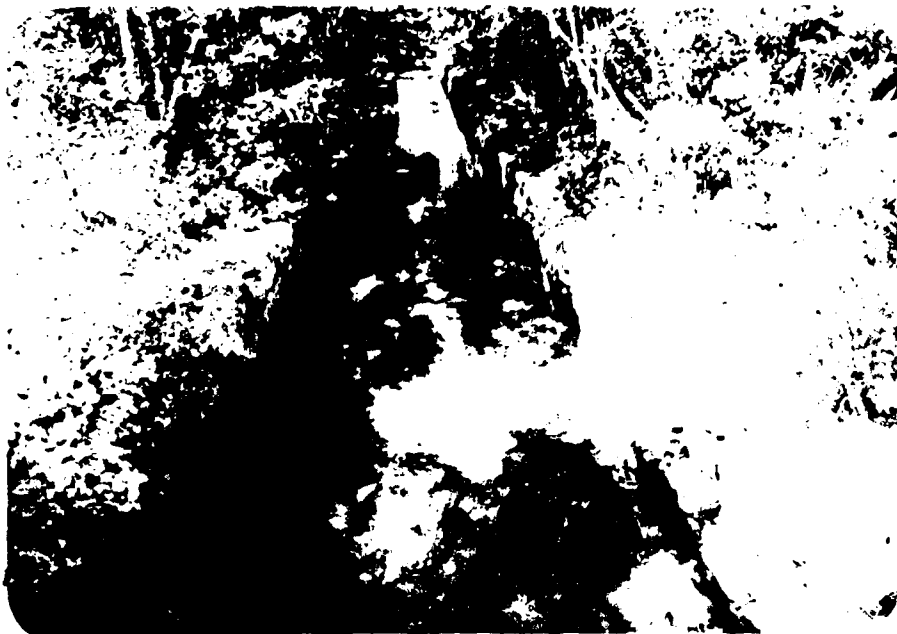

5

VIEW OF DISCHARGE CHANNEL LOOKING UPSTREAM AT DAM



8

BRIDGE 250 FEET DOWNSTREAM OF DAM

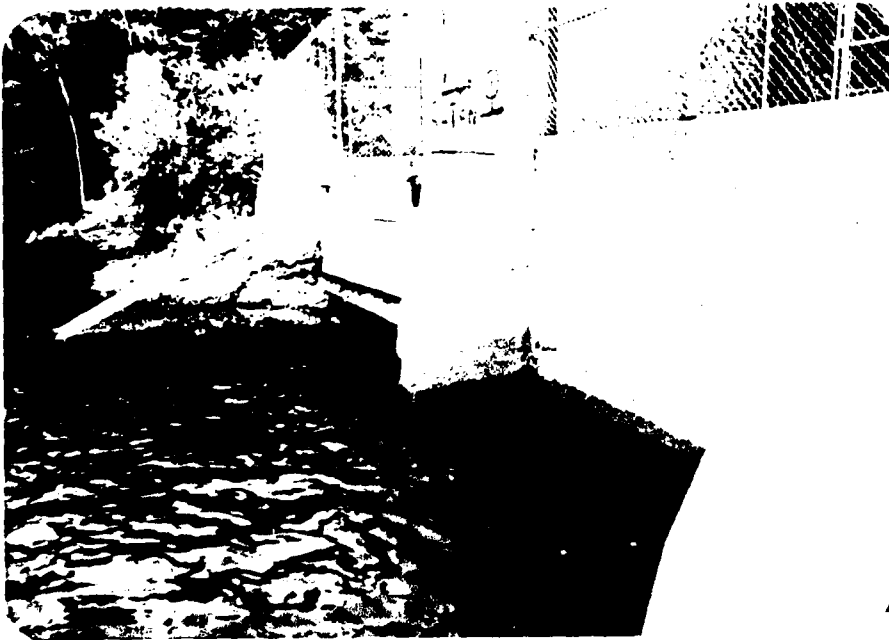

3

CONTROL GATE INTAKE STRUCTURE

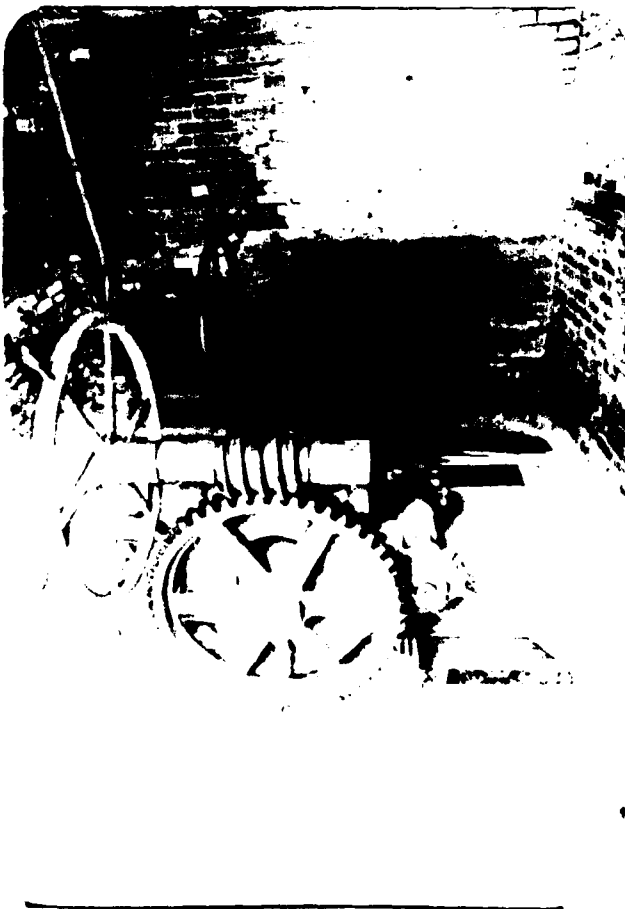

4

CONTROL GATE MECHANISM

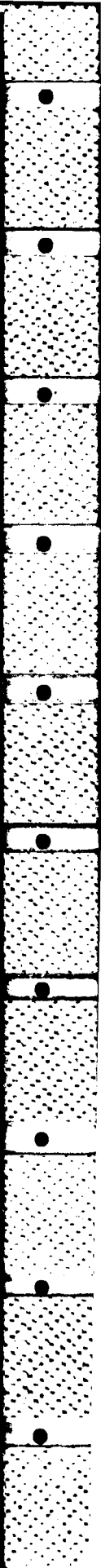



1

UPSTREAM VIEW OF DAM



2

VIEW OF MOUSAM LAKE FROM DAM

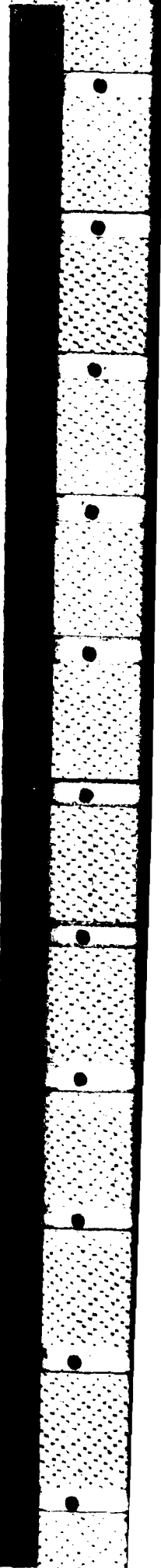

APPENDIX C

PHOTOGRAPHS

The following are photographs referenced in this report.
See Sheet B-1.1 for photograph locations and orientations.

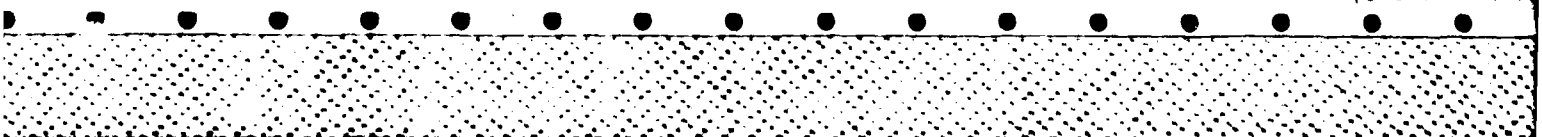
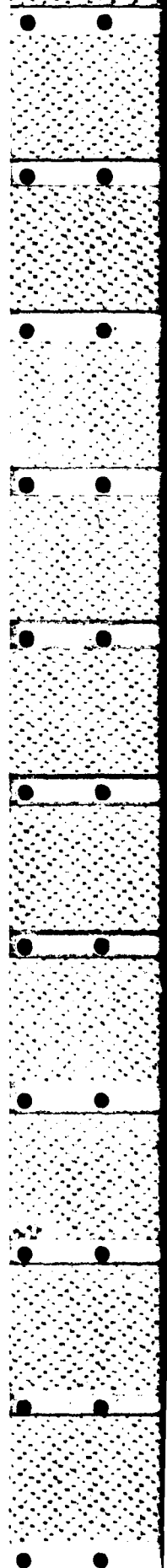

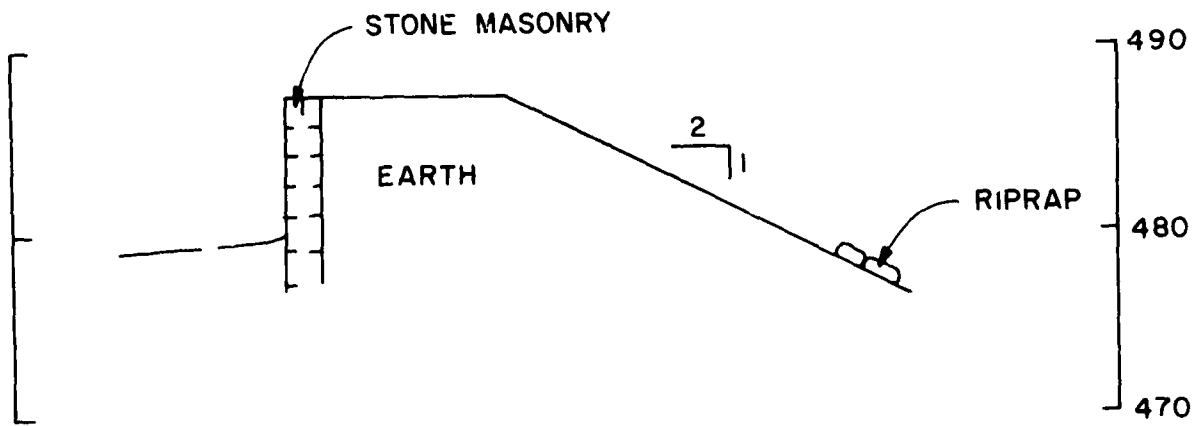

SECTION E

B-1.4

DRAWN: []	SCALE: []
CHECKED: []	DATE: []
NATIONAL PROGRAM OF INSPECTION OF NON-FED DAMS	
EMERY MILLS DAM	
X-SECTIONS	
MOUSAM RIVER	MAINE
DATE: OCTOBER 1978	

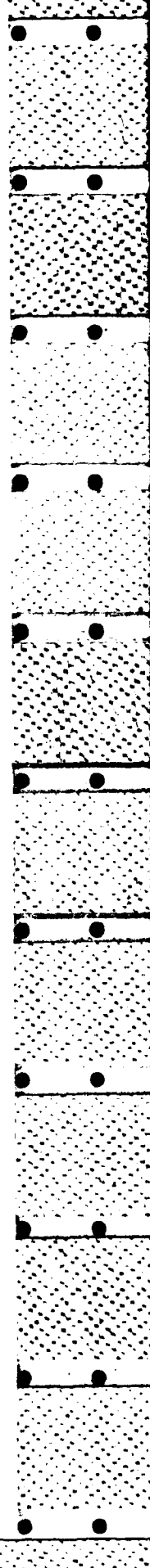

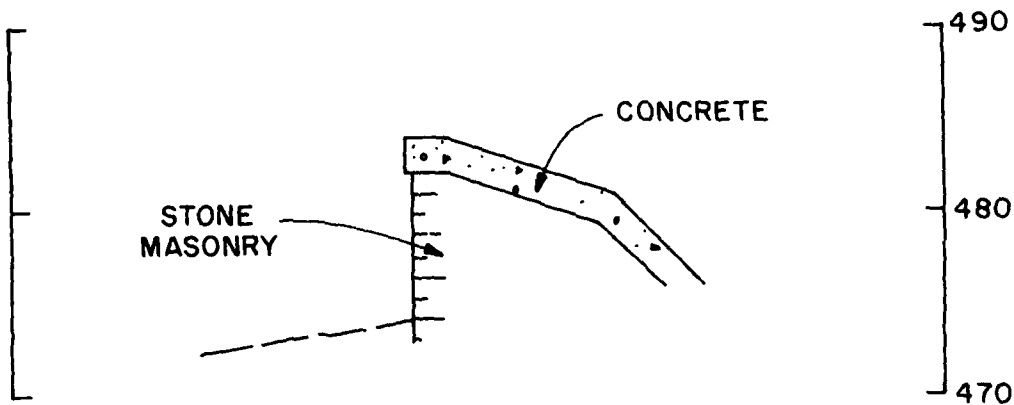

SECTION C

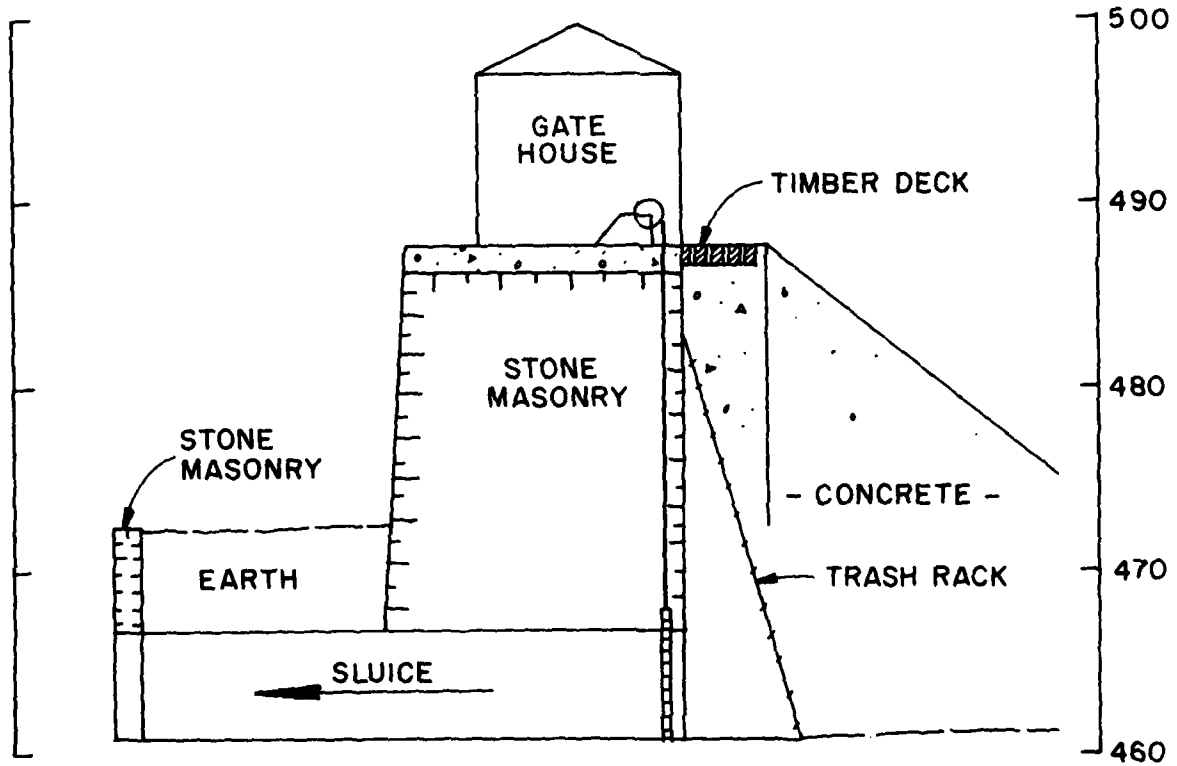

SECTION D

B-1.3

DRAWN: H. MOAN	SCALE: AS SHOWN
PROJ. ENG. DR. BY	DATE: 10/20/77
NATIONAL PROGRAM OF INSPECTION OF NON FED DAMS	
EMERY MILLS DAM	
X - SECTIONS	
MOUSAM RIVER MAINE	
OCTOBER 1978	

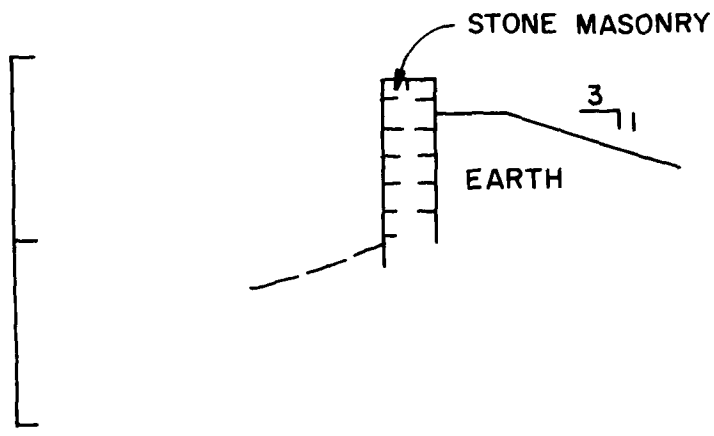

SECTION A

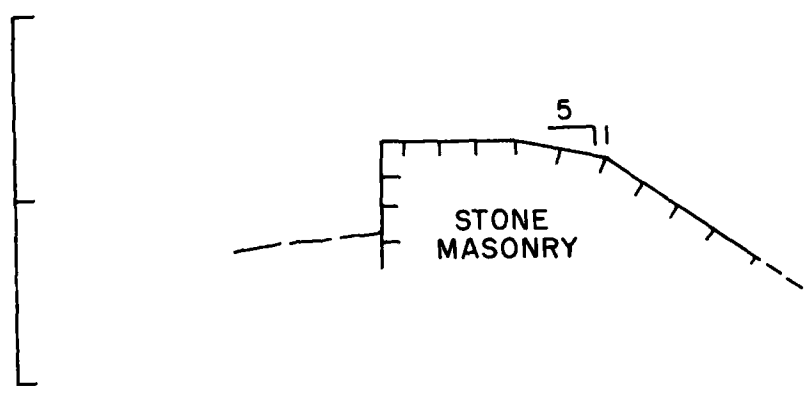
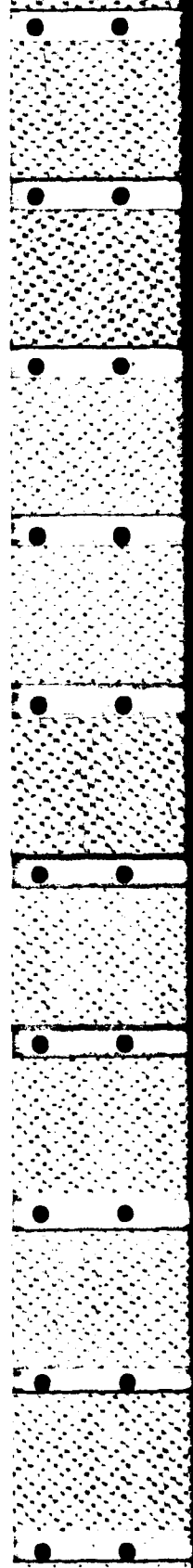
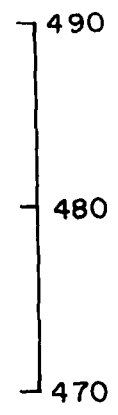

SECTION B

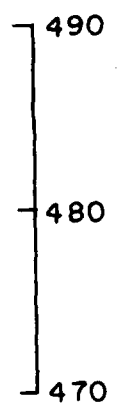

B-1.2

OWNER: STATE OF MAINE	PROJECT: MOUSAM RIVER DAM
NATIONAL PROGRAM OF INSPECTION OF NON-FED DAMS	
EMERY MILLS DAM	
X-SECTIONS	
MOUSAM RIVER MAINE	
DATE: OCTOBER 1978	

LAKE

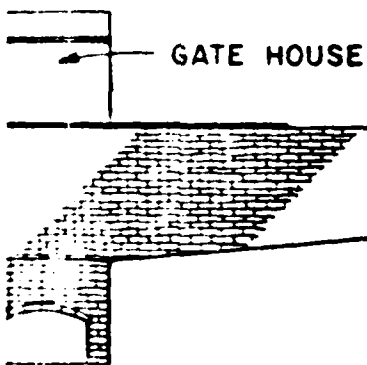
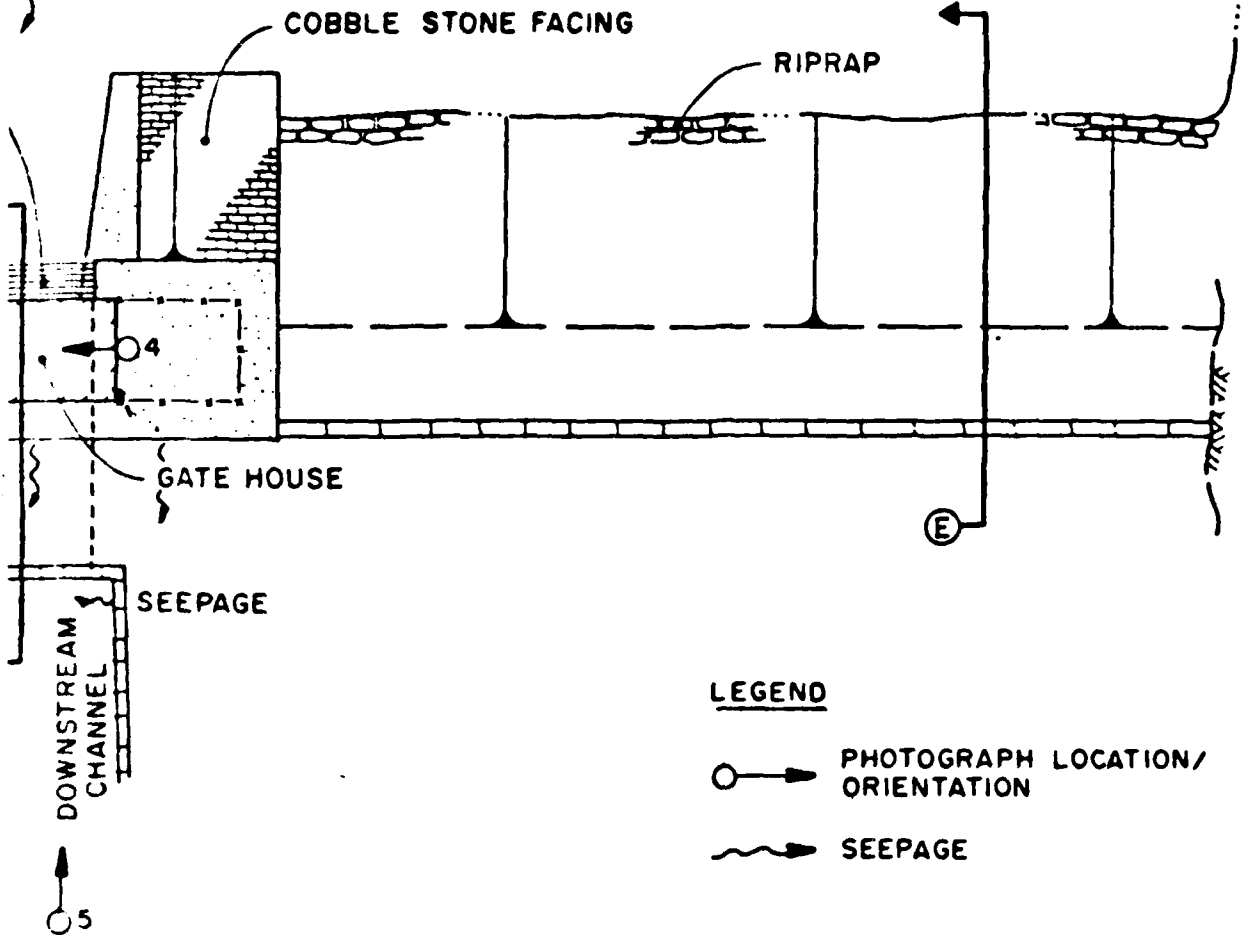

B-1.1

PROJECT: 27000	DATE: 1978
NO. 100	NO. 100
NATIONAL PROGRAM OF INSPECTION OF NON-FED DAMS	
EMERY MILLS DAM	
PLAN AND PROFILE	
MOUSAM RIVER	MAINE
JULY 1978	

1 2 of 2

MOUSAM LAK



AREA OF EROSION

TIMBER DECK

SPILLWAY

10

(A)

3:1

(B)

(C)

2

SEEPAGE

- TREES & DEBRIS -

DOWNSTREAM CHANNEL

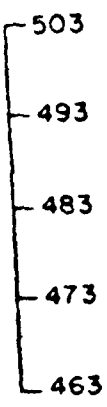

TB-1.1

1 of 2

APPENDIX B
GENERAL PROJECT DATA

Three drawings of the Emery Mills Dam were found to be available at the Municipal Building, Sanford, Maine. These include: 1) "Plan of Land and Water Power, Springvale Mfg. Company, Surveyed Dec. 1886, E.C. Jordan Civ. Eng.," 2) "Sanford Mills, Long Pond Dam," Drawing No. M-1080," dated July 13, 1934, and 3) a drawing of details and dimensions dated July 26, 1935.

A plan, elevation, and cross-sections, with limited detail, developed as a part of the visual inspection of the dam, are attached to this section.

- b. Sedimentation - the watershed has remained essentially rural in nature over the past several years. There are no new developments or new sources of sediment loads on the lake.
- c. Potential Upstream Hazard Areas - Mousam Lake has many cottages surrounding it, many of which would be affected by probable maximum flood elevations, but not by maximum water storage pool elevation.
- d. Watershed Runoff Potential - this watershed is of a rural nature with a significant percentage of its area as lakes and ponds.

7. DOWNSTREAM CHANNEL

The channel downstream of the gated outlet appears to have sufficient capacity to carry away flood flows from the dam. However, there is no defined channel below the spillway. The area is grown up with trees and bushes and littered with debris. In the event of failure of the dam, there would be damage to structures and property at least as far down as the Mill Street Dam in Sanford. Thus the Emery Mills Dam is classified as having a high hazard potential.

8. OPERATING AND MAINTENANCE FEATURES

- a. Reservoir Regulations Plan - no formal plan available.
- b. Maintenance - visual observation indicated that maintenance at the dam is done on an as-needed basis. The operating facilities were found to be in good mechanical order. The dam structure, however, appears to lack the benefit of routine maintenance.

- a. Inlet Structure - the inlet structure consists of concrete wing walls which form a channel to the outlet gates. A trash screen consisting of steel grating is upstream of the gates. An accumulation of debris was observed on the trash screen. The location of the screen is such that it would be very difficult to remove debris from its surface.
- b. Operating and Emergency Control Gates - the gates are raised by means of a vertical rack and gear. The gate stems, one for each gate, consist of steel beams. These beams appear to be in good condition; very little corrosion has occurred. The gate operating equipment was found to be in good repair. See photograph 4. The gates were operated during the inspection and it was observed that they operated properly.
- c. Conduit, Sluices and Water Passages - the outlet sluiceway consists of stone masonry. It was found to be in good condition. No erosion was observed.
- d. Stilling Basin - below the outlet sluiceway is a bedrock lined channel with stone masonry training walls. No erosion was observed in this area below the outlet.
- e. Approach and Outlet Channel - the approach channel to the outlet gates is clear and unobstructed, however the trash screen is littered with debris and appears to be very difficult to clean due to its location in the intake channel. The outlet channel is clear and unobstructed.
- f. Drawdown Facilities - A gated outlet is available for drawdown, but, due to the large storage capacity of the reservoir, the outlet is of little use in drawing down the impoundment (would take approximately 2 months).

5. INSTRUMENTATION

None.

6. RESERVOIR

- a. Shore Line - no major active or inactive landslide areas on Mousam Lake were observed.

PROJECT Dam Safety Emery Mills Dam	COMP BY	JOB NO.
	JHF	20583 08
	CHK BY	DATE
	RTB	10/4/78

General Information

Concrete Dam
252 feet wide
26 feet high
Capacity 38,000 Acre-feet

Available Drawdown - 22'
Drainage area - 29.27 mi²
Spillway Crest elevation - 484' above MSL
Normal water elevation - 481' above MSL

1 yr. flood - 570 cfs.
10 yr. flood - 1200 cfs.
20 yr. flood - 1590 cfs

50 yr. flood - 2280 cfs.
100 yr. flood - 2900 cfs.

Hydraulics

Invert = 463' above MSL

$Q = CA\sqrt{2gh}$ where; $c = 0.7$, $A = 24$

Elevation	Q	Elevation	Q	Elevation	Q
466.0	165	477.0	477	488.0	654
.5	191	.5	486	.5	660
467.0	213	478.0	495	489.0	667
.5	234	.5	504	.5	674
468.0	252	479.0	513	490.0	681
.5	270	.5	522	.5	687
469.0	286	480.0	531	491.0	694
.5	301	.5	539	.5	701
470.0	316	481.0	548	492.0	707
.5	330	.5	556	.5	713
471.0	344	482.0	564	493.0	720
.5	357	.5	572	.5	726
472.0	369	483.0	580	494.0	732
.5	381	.5	588	.5	738
473.0	393	484.0	595	495.0	745
.5	404	.5	603	.5	751
474.0	416	485.0	610	496.0	757
.5	426	.5	618		
475.0	437	486.0	625		
.5	447	.5	632		
476.0	457	487.0	640		
.5	467	.5	647		

PROJECT Dam Safety Emery Mills	COMP BY JHF	JOB No 20583 08
	CHK BY BTB	DATE 10/4/78

$$Q = CLH^{3/2}$$

Elevation above MSL	Weir #1 L=15'; Crest=488 W=2.5'		Weir #4 L=34'; Crest=484 W=15.8'		Weir #5 L=17.5'; Crest=482.5 W=18.75'		Weir #6 L=12.3'; Crest=487.5 W=18.75'	
	Q	C	Q	C	Q	C	Q	C
483.0	-	-	-	-	-	-	-	-
483.5	-	-	-	-	-	-	-	-
484.0	-	-	-	-	-	-	-	-
484.5	-	-	-	-	-	-	-	-
485.0	-	-	-	-	-	-	-	-
485.5	-	-	-	-	-	-	-	-
486.0	-	-	-	-	-	-	-	-
486.5	-	-	-	-	-	-	-	-
487.0	-	-	-	-	-	-	-	-
487.5	-	-	-	-	-	-	-	-
488.0	-	-	14	2.70	16	2.63	95	2.63
488.5	14	2.60	40	2.63	46		269	
489.0	40	2.64	73	2.63	85		494	
489.5	75	2.71	112		130		761	
490.0	117	2.76	156		182		1064	
490.5	171	2.89	205		239		1398	
491.0	238	3.05	258		301		1762	
491.5	313	3.19	316		368		2152	
492.0	398	3.32	377		439		2568	
492.5	375		441		515		3008	
493.0	557		509		594		3470	
493.5	642		580		676		3954	
494.0	732		654		763		4459	
494.5	825		731		852		4983	
495.0	922		810		945		5526	
495.5	1023		893		1041		6088	
496.0	1127		978		1141		6667	

PROJECT Dam Safety - Emery Mills	COMP BY BTB	JOB NO. 2058308
	CHK BY JHF	DATE 10/9/78

Elevation above msl	Weir # 2 L = 25.4 Crest = 483 W = 17.5		Weir # 3 L = 34 Crest = 484 W = 13.0	
	Q	C	Q	C
483.0	-	-	-	-
.5	28	3.13	-	-
484.0	79	3.14	-	-
.5	145	3.10	38	3.13
485.0	226	3.14	107	3.14
.5	321	3.20	194	3.10
486.0	430	3.26	302	3.14
.5	551	3.31	430	3.20
487.0	685	3.37	576	3.26
.5	817		737	3.31
488.0	957		917	3.37
.5	1104		1093	
489.0	1258		1281	
.5	1419		1478	
490.0	1585		1684	
.5	1758		1899	
491.0	1937		2122	
.5	2121		2353	
492.0	2311		2593	
.5	2506		2839	
493.0	2707		3094	
.5	2912		3355	
494.0	3123		3623	
.5	3338		3898	
495.0	3558		4180	
.5	3783		4468	
496.0	4012		4763	

Use figure 5-23 for C values, Table 5-13
 P5-44 Brater & King, Handbook of Hydraulics, 1976

PROJECT Dam Safety Emery Mills	COMP BY JWF	JOB NO. 2458308
	CHK BY BTB	DATE 10/4/78

Elevation above MSL	Total Discharge cfs	Elevation above MSL	Total Discharge cfs
463.0	0	481.0	548
466.0	165	.5	556
.5	191	482.0	564
467.0	213	.5	572
.5	234	483.0	580
468.0	252	.5	616
.5	270	484.0	674
469.0	286	.5	786
.5	301	485.0	943
470.0	316	.5	1133
.5	330	486.0	1357
471.0	344	.5	1613
.5	357	487.0	1901
472.0	369	.5	2201 *
.5	381	488.0	2653
473.0	393	.5	3226
.5	404	489.0	3898
474.0	416	.5	4649
.5	426	490.0	5469
475.0	437	.5	6357
.5	447	491.0	7312
476.0	457	.5	8324
.5	467	492.0	9393
477.0	477	.5	10497
.5	486	493.0	11651
478.0	495	.5	12845
.5	504	494.0	14086
479.0	513	.5	15306
.5	522	495.0	16686
480.0	531	.5	18047
.5	539	496.0	19445

* Full
Spillway

PROJECT Dam Safety - Emery Mills Storage above spillway crest	COMP BY JHF	JOB NO. 20583 08
	CHK BY STB	DATE 10/6/78

WATER Surface Elevation	Surface Area Acres	Surcharge Storage Acre-feet	Discharge cfs
481	933	0	548
482	1000	1000	564
483	1070	2070	580
484	1140	3210	674
485	1210	4420	943
486	1280	5700	1357
487	1350	7050	1901
488	1420	8470	2653
489	1490	9960	3898
490	1560	11520	5469
491	1640	13160	7312
492	1710	14870	9393
493	1780	16650	11651
494	1850	18500	14086
495	1920	20420	16686
496	1990	22410	19445

$$Q_{p1} = 16680 \left\{ \text{from Guidance for Estimating FIMF} \right\}$$

Water elev. to pass $Q_{p1} = 495.0'$

$$\text{STOR}_1: \text{Storage @ } 495.0 = 20420 \text{ acre-ft.}$$

$$\text{Drainage area (tributary to Emery Mills)} = 29.27 \text{ mi}^2 \times 640 \frac{\text{acres}}{\text{mi}^2} \\ = 18733 \text{ acres}$$

$$\text{STOR}_2 = \frac{20420}{18733} \times \frac{13'}{1'} = 13.1''$$

$$Q_{p2} = 16680 \times \left(1 - \frac{13.1}{19}\right) = 5180 \text{ cfs}$$

Water elevation to pass $Q_{p2} = 489.82'$

$$\text{Storage @ } 489.82 = 11239 \text{ acre-ft.}$$

PROJECT Dam Safety Emery Mills	COMP BY JHF	JOB NO. 2050302
	CHK BY BTB	DATE 10/6/78

$$STOR_2 = \frac{11239}{18733} \times \frac{12''}{1'} = 7.2''$$

$$\text{Average}_1 = \frac{7.2 + 13.1}{2} = 10.2''$$

$$Q_{p3} = 16680 \times \left(1 - \frac{10.2}{19}\right) = 7725 \text{ cfs}$$

$$STOR_3 = \frac{13502}{18733} \times \frac{12''}{1'} = 8.6''$$

$$\text{Average}_2 = \frac{8.6 + 10.2}{2} = 9.4''$$

$$Q_{p4} = 16680 \left(1 - \frac{9.4}{19}\right) = 8428 \text{ cfs}$$

$$STOR_4 = \frac{14077}{18733} \times \frac{12''}{1'} = 9.0''$$

$$\text{Average}_3 = \frac{9.0 + 9.4}{2} = 9.2''$$

$$Q_{p5} = 16680 \left(1 - \frac{9.2}{19}\right) = 8603 \text{ cfs}$$

$$STOR_5 = \frac{14221}{18733} \times \frac{12''}{1'} = 9.1''$$

$$\text{Average}_4 = \frac{9.1 + 9.2}{2} = 9.15''$$

$$Q_{p6} = 16680 \left(1 - \frac{9.15}{19}\right) = 8647 \text{ cfs}$$

$$STOR_6 = \frac{14257}{18733} \times \frac{12''}{1'} = 9.13''$$

$$\text{Average}_5 = \frac{9.13 + 9.15}{2} = 9.14''$$

$$Q_{p7} = 16680 \left(1 - \frac{9.14}{19}\right) = 8656 \text{ cfs}$$

$$STOR_7 = \frac{14264}{18733} \times \frac{12''}{1'} = 9.14''$$

end of
iteration

\therefore routed flow = $Q_{p7} = 8660 \text{ cfs}$

Elevation 491.65'

PROJECT	Downstream Failure Hydrographs Emery Mills	COMP BY	JOB NO.
		JWF	20583 08
		CHK BY	DATE
		BTB	10/5/78

$$Q_{p1} = \frac{8}{27} W_b \sqrt{g} Y_0^{3/2}$$

$$\frac{1}{2} Q_p T = 12.1 S$$

$$W_b = 0.4 (102.3) = 41'$$

$$Y_0 = 487.5 - 462.5 = 25'$$

$$\therefore Q_{p1} = \frac{8}{27} \times 41 \times \sqrt{32.2} \times (25)^{3/2}$$

$$= 8617 \text{ cfs.}$$

STORAGE @ FULL SPILLWAY

$$S = \frac{(24.5)(2300)(29300)}{43560} = 37903 \text{ acre-ft.}$$

$$T = \frac{(12.1)(37903)}{(5)(8617)}$$

$$= 106 \text{ hrs.} = 4.4 \text{ days}$$

STORAGE @ SPILLWAY CREST

$$S = \frac{(20)(2300)(29300)}{43560} = 30941 \text{ acre-ft.}$$

PROJECT Dam Failure Hydrographs Energy Mills	COMP BY JHF	JOB NO. 20583 08
	CHK BY BTS	DATE 10/5/28

X-Section #1 : Intersection Mousam River &
460' contour ~ 2000 ft. below dam

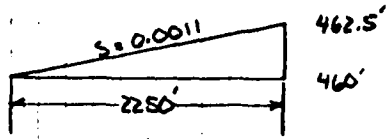
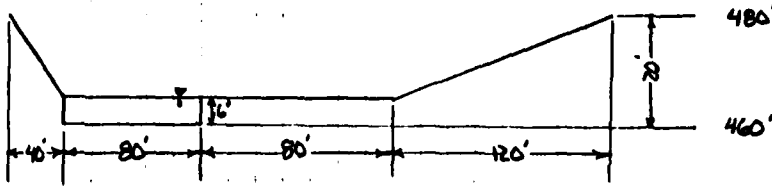

Elevation 466' n = 0.06

$$Q = \frac{1.49}{0.06} (480) \left(\frac{480}{42} \right)^{2/3} (0.0011)^{1/2}$$

$$= 1190 \text{ cfs} \quad V = 2.5 \text{ fps}$$

Elevation 470'

$$Q = \frac{1.49}{0.06} \left[\left(\frac{4 \times 8}{2} \right) + \left(\frac{4 \times 24}{2} \right) + (4 \times 160) \right] \left(\frac{193}{193} \right)^{2/3} (0.0011)^{1/2}$$

$$= 1375 \text{ cfs}$$

$$Q_{\text{TOTAL}} = 1375 + 1190 = 2565 \text{ cfs.}$$

Elevation 475'

$$Q = \frac{1.49}{0.06} \left[\left(\frac{9 \times 18}{2} \right) + \left(\frac{9 \times 54}{2} \right) + (9 \times 160) \right] \left(\frac{235}{235} \right)^{2/3} (0.0011)^{1/2}$$

$$Q = 5314 \text{ cfs}$$

$$Q_{\text{TOTAL}} = 2565 + 5314 = 6504 \text{ cfs.}$$

Elevation 480'

$$Q = \frac{1.49}{0.06} \left[\left(\frac{14 \times 28}{2} \right) + \left(\frac{14 \times 84}{2} \right) + (14 \times 160) \right] \left(\frac{277}{277} \right)^{2/3} (0.0011)^{1/2}$$

$$Q = 12267 \text{ cfs}$$

$$Q_{\text{TOTAL}} = 12267 + 6504 = 13457 \text{ cfs}$$

PROJECT Cross section #1 ; Dam failure analysis Emery Mills Dam	COMP BY JHF	JOB NO. 2058308
	CHK BY BTB	DATE 10/6/78

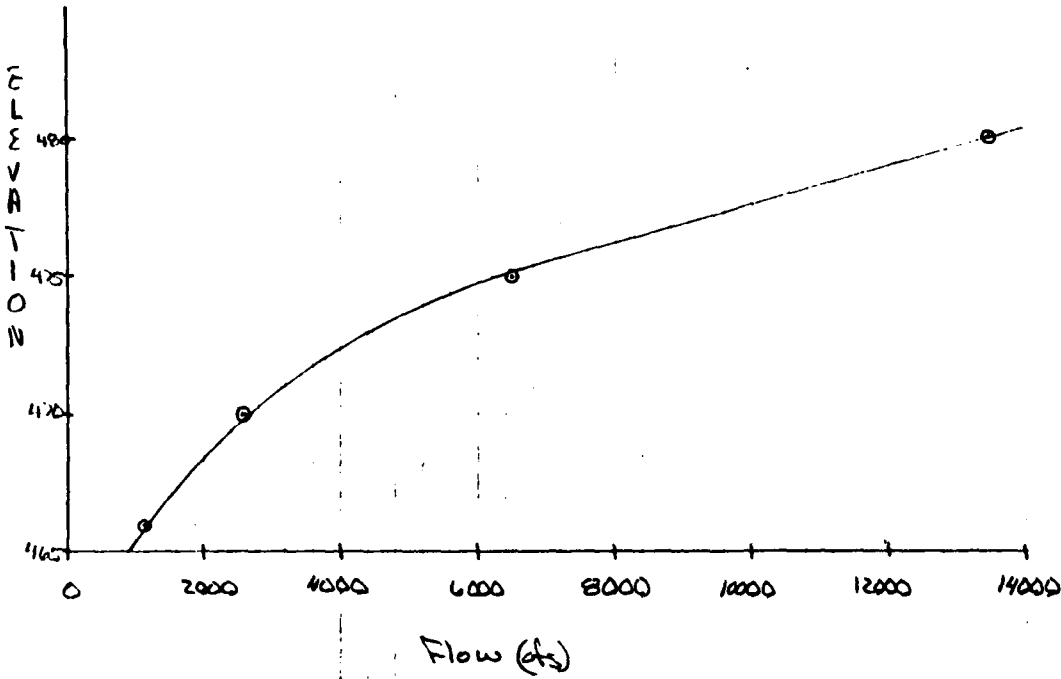

Elevation

- 470
- 471
- 472
- 473
- 474
- 475
- 476
- 477
- 478
- 479
- 480

Flow (cfs)

- 2570
- 3200
- 3800
- 4400
- 5200
- 6300
- 7600
- 9200
- 10600
- 12200
- 13500

PROJECT Cross Section #1 Emercy Mills - main	COMP BY JHF	JOB NO. 20583 CB
	CHK BY ZFE	DATE 10/6/78

$$Q_{p1} = 8617 \text{ cfs.}$$

$$\text{Stage @ Cross Section \#1} = 476.64'$$

$$V_1 = \frac{(16.64)(2250)(83)}{43560} = 71.3 \text{ acre-ft.}$$

$$Q_{p2}(\text{trial}) = 8617 \left(1 - \frac{71.3}{37903}\right) = 8601 \text{ cfs.}$$

$$\text{Stage} = 476.63'$$

$$V_2 = \frac{(16.63)(2250)(83)}{43560} = 71.3 \text{ acre-ft.}$$

$$V_{\text{average}} = 71.3 \text{ acre-ft.}$$

$$Q_{p2} = 8617 \left(1 - \frac{71.3}{37903}\right) = 8600 \text{ cfs.}$$

$$Q_{p2} = 8600 \text{ cfs.}$$

PROJECT Cross-Section #2 junction Mouram River & Ate. 109 6500' below dam	COMP BY INF	JOB NO. 2058308
	CHK BY BTR	DATE 10/6/78

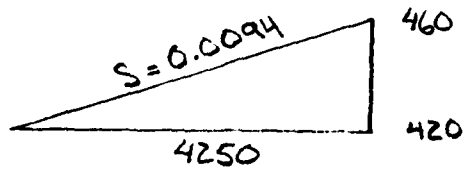
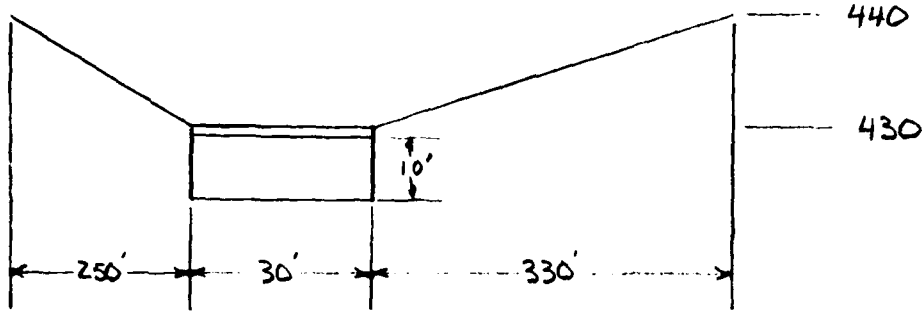

n = 0.06

Elevation 436'

$$Q = \frac{1.49}{0.06} (300) \left(\frac{300}{80} \right)^{2/3} (0.0094)^{1/2}$$

$$Q = 1744 \text{ cfs.}$$

Elevation 435'

$$Q = \frac{1.49}{0.06} \left[\left(\frac{125 \times 5}{2} \right) + \left(\frac{35 \times 30}{2} \right) + 150 \right] \left(\frac{150}{320} \right)^{2/3} (0.0094)^{1/2}$$

$$Q = 4121 \text{ cfs.}$$

$$Q_{\text{total}} = 5865 \text{ cfs.}$$

Elevation 440'

$$Q = \frac{1.49}{0.06} \left[\left(\frac{2500}{2} \right) + \left(\frac{3300}{2} \right) + 300 \right] \left(\frac{60}{610} \right)^{2/3} (0.0094)^{1/2}$$

$$Q = 23274 \text{ cfs.}$$

$$Q_{\text{TOTAL}} = 24448 \text{ cfs.}$$

PROJECT Cross-Section #2
 Junction Mousam River & Rte. 109

COMP BY
 JKF
 CHK BY
 BTE

JOB NO.
 2058308
 DATE
 10/6/78

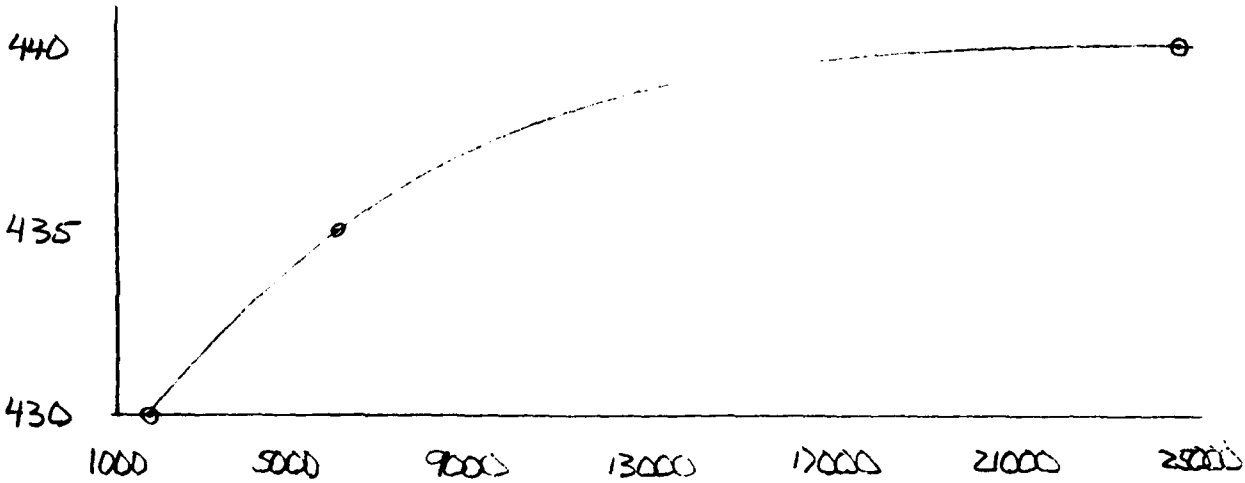

ELEVATION

FLOW

430	1744
431	2300
432	3100
433	3900
434	4800
435	5865
436	7000
437	8500
438	10000
439	13000
440	24448

BT Cross Section #2	COMP BY JHF	JOB NO. 2058308
	CHK BY BTE	DATE 10/6/78

$$Q_{p2} = 8600 \text{ cfs.}$$

$$\text{Stage @ X-Section \#2} = 437.07'$$

$$V_1 = \frac{(16.63 + 17.07) (60) (4500)}{43560} = 104.4 \text{ acre-ft.}$$

$$Q_{p3} (\text{trial}) = 8600 \left(1 - \frac{104.4}{37903}\right) = 8576 \text{ cfs}$$

$$\text{Stage} = 437.05'$$

$$V_2 = \frac{(16.63 + 17.05) (60) (4500)}{43560} = 104.4 \text{ acre-ft.}$$

$$V_{\text{average}} = 104.4 \text{ acre-ft.}$$

$$Q_{p3} = 8580 \text{ cfs.}$$

Cross Section #3 @ Mill St. Dam

following from hydraulic calculations for Mill St. Dam

Elevation	Flow (cfs.)
348	555
349	1106
350	2429
351	4824
352	8060
353	11933
354	14080
355	16356

ECT Cross Section #3	COMP BY JAF	JOB NO. 2058308
	CHK BY BTB	DATE 10/9/78

$$Q_{p3} = 8580 \text{ cfs.}$$

$$\text{Stage @ X-Section \#3} = 352.13'$$

$$V_1 = \frac{(17.05 + 19.13)(200)(12000)}{43560} = 996.7 \text{ acre-ft.}$$

$$Q_{p4}(\text{trial}) = 8580 \left(1 - \frac{996.7}{37903}\right) = 8354 \text{ cfs}$$

$$\text{Stage} = 352.08'$$

$$V_2 = \frac{(17.05 + 19.08)(200)(12000)}{43560} = 995 \text{ acre-ft.}$$

$$V_{\text{average}} = 996 \text{ acre-ft.}$$

$$Q_{p4} = 8580 \left(1 - \frac{996}{37903}\right) = 8355 \text{ cfs.}$$

$$\text{Elevation to pass } Q_{p4} = 352.08'$$

4.08' over spillway

~ 2.58' over dike

APPENDIX E
INFORMATION AS CONTAINED IN
THE NATIONAL INVENTORY OF DAMS

INVENTORY OF DAMS IN THE UNITED STATES

STATE	DIVISION	COUNTY	DISTRICT	COUNTY	DISTRICT	NAME	LATITUDE (NORTH)	LONGITUDE (WEST)	REPORT DATE
ME	106	NED	ME	031	01	EMERY MILLS DAM	4329.6	7050.9	180CT78

POPULAR NAME	NAME OF IMPONDMENT		
	MOUSAM LAKE		
REGION/BASIN	RIVER OR STREAM	NEAREST DOWNSTREAM CITY-TOWN-VILLAGE	DIST FROM DAM (MI.)
01 04	MOUSAM RIVER	SPRINGVALE	3
TYPE OF DAM	YEAR COMPLETED	PURPOSES	POPULATION
GRC1REP6	1900	OC	3000

TYPE OF DAM	YEAR COMPLETED	PURPOSES	HYDRAULIC HEAD (FEET)	IMPOUNDING CAPACITIES (ACRES-FT.)	DIST OWN	FED R	PRV/FED	SCS A	VER/DATE
GRC1REP6	1900	OC	25	18	45700	N	N	N	180CT78

REMARKS

DIS HAS	SPILLWAY CREST LENGTH (FT.)	WIDTH (FT.)	TYPE	VOLUME OF DAM (CY)	MAXIMUM DISCHARGE (FT.)	POWER CAPACITY (MW)	INSTALLED	PROPOSED	NO	NAVIGATION LOCKS
1	U	60		2720						

OWNER	ENGINEERING BY	CONSTRUCTION BY
TOWN OF SANFORD		

DESIGN	CONSTRUCTION	OPERATION	MAINTENANCE
NONE	NONE	NONE	NONE

INSPECTION BY	AUTHORITY FOR INSPECTION
EDWARD C. JORDAN CO., INC.	07SEP78 PL 92-367

REMARKS

END

FILMED

7-85

DTIC