

MICROCOPY RESOLUTION TEST CHART
NATIONAL BUREAU OF STANDARDS-1963-A

PHOTOGRAPH THIS SHEET

AD-A 154 690

DTIC ACCESSION NUMBER

II

LEVEL

1

INVENTORY

MA 00979

DOCUMENT IDENTIFICATION

Aug 1978

DISTRIBUTION STATEMENT A
Approved for public release;
Distribution Unlimited

DISTRIBUTION STATEMENT

ACCESSION FOR	
NTIS	GRA&I <input checked="" type="checkbox"/>
DTIC	TAB <input type="checkbox"/>
UNANNOUNCED	<input type="checkbox"/>
JUSTIFICATION	
BY	
DISTRIBUTION /	
AVAILABILITY CODES	
DIST	AVAIL AND/OR SPECIAL
A-1	

DISTRIBUTION STAMP



DTIC ELECTE
JUN 7 1985
S P D

DATE ACCESSIONED

DATE RETURNED

85 6 7 151

DATE RECEIVED IN DTIC

REGISTERED OR CERTIFIED NO.

PHOTOGRAPH THIS SHEET AND RETURN TO DTIC-DDAC

MERRIMACK RIVER BASIN
HOLDEN, MASSACHUSETTS

EAGLE LAKE DAM

MA 00979

PHASE I INSPECTION REPORT
NATIONAL DAM INSPECTION PROGRAM

AD-A154 690



DEPARTMENT OF THE ARMY
NEW ENGLAND DIVISION, CORPS OF ENGINEERS
WALTHAM, MASSACHUSETTS 02154

AUGUST 1978

UNCLASSIFIED

SECURITY CLASSIFICATION OF THIS PAGE (When Data Entered)

REPORT DOCUMENTATION PAGE		READ INSTRUCTIONS BEFORE COMPLETING FORM
1. REPORT NUMBER MA 00979	2. GOVT ACCESSION NO.	3. RECIPIENT'S CATALOG NUMBER
4. TITLE (and Subtitle) Eagle Lake Dam NATIONAL PROGRAM FOR INSPECTION OF NON-FEDERAL DAMS		5. TYPE OF REPORT & PERIOD COVERED INSPECTION REPORT
		6. PERFORMING ORG. REPORT NUMBER
7. AUTHOR(s) U.S. ARMY CORPS OF ENGINEERS NEW ENGLAND DIVISION		8. CONTRACT OR GRANT NUMBER(s)
9. PERFORMING ORGANIZATION NAME AND ADDRESS		10. PROGRAM ELEMENT, PROJECT, TASK AREA & WORK UNIT NUMBERS
11. CONTROLLING OFFICE NAME AND ADDRESS DEPT. OF THE ARMY, CORPS OF ENGINEERS NEW ENGLAND DIVISION, NEDED 424 TRAPELO ROAD, WALTHAM, MA. 02254		12. REPORT DATE August 1978
		13. NUMBER OF PAGES 35
14. MONITORING AGENCY NAME & ADDRESS (if different from Controlling Office)		15. SECURITY CLASS. (of this report) UNCLASSIFIED
		15a. DECLASSIFICATION/DOWNGRADING SCHEDULE
16. DISTRIBUTION STATEMENT (of this Report) APPROVAL FOR PUBLIC RELEASE: DISTRIBUTION UNLIMITED		
17. DISTRIBUTION STATEMENT (of the abstract entered in Block 20, if different from Report)		
18. SUPPLEMENTARY NOTES Cover program reads: Phase I Inspection Report, National Dam Inspection Program; however, the official title of the program is: National Program for Inspection of Non-Federal Dams; use cover date for date of report.		
19. KEY WORDS (Continue on reverse side if necessary and identify by block number) DAMS, INSPECTION, DAM SAFETY, Merrimack River Basin Holden Massachusetts Asnebumskit Brook		
20. ABSTRACT (Continue on reverse side if necessary and identify by block number) The dam comprises a concrete ogee spillway section with earthfill abutments behind concrete wing walls. The total height of the dam is about 20 ft. It is small in size with a high hazard classification. The potential hazard to property, and possible human life, is the proximity of the industrial complex to the reservoir and the inadequacy of the channel through the complex to convey high flows, be they the result of high and continued precipitation or a failure of the dam.		

EAGLE LAKE DAM

MA 00979

MERRIMACK RIVER BASIN
HOLDEN, MASSACHUSETTS

PHASE I INSPECTION REPORT
NATIONAL DAM INSPECTION PROGRAM

NATIONAL DAM INSPECTION PROGRAM

PHASE I INSPECTION REPORT

Identification No.: MA 00979
Name of Dam: Eagle Lake Dam
Town: Holden, Massachusetts
County and State: Worcester County, Massachusetts
Stream: Asnebumskit Brook
Date of Inspection: June 13, 1978

BRIEF ASSESSMENT

The Eagle Lake Dam comprises a concrete ogee spillway section with earthfill abutments behind concrete wing walls. The total height of the dam is about 20 feet. The spillway section is divided into three bays of 22 feet each. Two bays contain stoplogs, the third 4 sluice gates. The permanent water level of about 6 or 7 feet above the spillway crest is maintained by these devices. Although the dam is owned by an industrial concern, the reservoir is no longer used for industrial purposes but, rather, to support recreation for the town.

Immediately downstream of the spillway is an industrial building under which spillway discharge is meant to flow. Next, the channel proceeds between other industrial buildings and under a highway bridge to a less congested area. Immediately downstream of each abutment are other industrial buildings.

The drainage area of Eagle Lake is 6,560 acres and the reservoir area is about 80 acres. Inflows to Eagle Lake are highly dependent on the regulated or spillage outflows from Pine Hill Reservoir and Kendall Reservoir, two large upstream reservoirs within the watershed. A detailed hydrologic analysis of Eagle Lake could not be performed without including the analysis of these two other projects. The possible effects of these two reservoirs was not considered in this cursory study of Eagle Lake.

Owing to its height and impoundment volume, the dam falls within the small size classification. Its apparent high hazard potential, however, mandated hydraulic analysis using the full probable maximum flood.

Reservoir storage would reduce the probable maximum flood of 16,800 cfs to 16,000 cfs. The sluice gates and spillway structure without stoplogs can discharge approximately 5,000 cfs (32 percent of the test flood). The overtopping of the dam during the test flood would be about 6 feet.

As the lake level is maintained more or less permanently by the gates and stoplogs, and the vertical distance between their tops and the underside of the bridge across the spillway is less than 2 feet, the situation was also analyzed assuming the complete disfunction of the spillway. The resulting overtopping of the entire structure would amount to 8 or 9 feet. A conservatively assumed Peak Failure Outflow would be in the same order of magnitude as the test flood.

The potential hazard to property, and possibly to human life, in any case, is the proximity of the industrial complex to the reservoir and the inadequacy of the channel through the complex to convey high flows, be they the result of high and continued precipitation or a failure of the dam.

The dam does not appear to be in danger of failure with the water at its normal level. Remedial measures that should be implemented by the owner within 12 months after receipt of the Phase I Inspection Report are described in Section 7. The key to minimizing the effects downstream is the ability of the owner to act quickly to raise the sluice gates and remove the stoplogs and to continue surveillance throughout periods of high flow.

In addition to developing such a flood warning system, the owner should make the necessary minor repairs, clean the spillway and downstream channel, and institute a program of regular inspection and maintenance which would include the periodic testing of the operability of the sluice gates and the removability of the stoplogs.

Additional investigations or major modifications are not necessary.

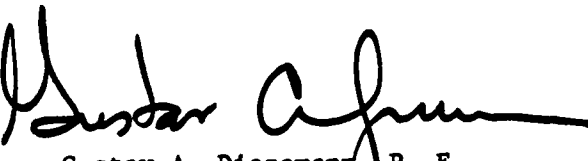
Gustav A. Diezemann, P. E.
New York State Lic. 27062

This Phase I Inspection Report on the Eagle Lake Dam has been reviewed by the undersigned Review Board members. In our opinion, the reported findings, conclusions, and recommendations are consistent with the Recommended Guidelines for Safety Inspection of Dams, and with good engineering judgment and practice, and hereby submitted for approval.

CHARLES G. TIERSCH, Chairman
Chief, Foundation and Materials Branch
Engineering Division

FRED J. RAVENS, Jr., Member
Chief, Design Branch
Engineering Division

SAUL COOPER, Member
Chief, Water Control Branch
Engineering Division

APPROVAL RECOMMENDED:

JOE B. FRYAR
Chief, Engineering Division

PREFACE

This report is prepared under guidance contained in the Recommended Guidelines for Safety Inspection of Dams, for Phase I Investigations. Copies of these guidelines may be obtained from the Office of Chief of Engineers, Washington, D.C. 20314. The purpose of a Phase I Investigation is to identify expeditiously those dams which may pose hazards to human life or property. The assessment of the general condition of the dam is based upon available data and visual inspections. Detailed investigation and analyses involving topographic mapping, subsurface investigations, testing, and detailed computational evaluations are beyond the scope of a Phase I investigation; however, the investigation is intended to identify any need for such studies.

In reviewing this report, it should be realized that the reported condition of the dam is based on observations of field conditions at the time of inspection, along with data available to the inspection team. In cases where the reservoir was lowered or drained prior to inspection, such action, while improving the stability and safety of the dam, removes the normal load on the structure and may obscure certain conditions which might otherwise be detectable if inspected under the normal operating environment of the structure.

It is important to note that the condition of a dam depends on numerous and constantly changing internal and external conditions, and is evolutionary in nature. It would be incorrect to assume that the present condition of the dam will continue to represent the condition of the dam at some point in the future. Only through continued care and inspection can there be any chance that unsafe conditions be detected.

Phase I inspections are not intended to provide detailed hydrologic and hydraulic analyses. In accordance with the established Guidelines, the Spillway Test flood is based on the estimated "Probable Maximum Flood" for the region (greatest reasonably possible storm runoff), or fractions thereof. Because of the magnitude and rarity of such a storm event, a finding that a spillway will not pass the test flood should not be interpreted as necessarily posing a highly inadequate condition. The test flood provides a measure of relative spillway capacity and serves as an aid in determining the need for more detailed hydrologic and hydraulic studies, considering the size of the dam, its general condition and the downstream damage potential.

TABLE OF CONTENTS

BRIEF ASSESSMENT	i
REVIEW BOARD SIGNATURE SHEET	iii
PREFACE	iv
TABLE OF CONTENTS	v
OVERVIEW PHOTO	vi
LOCATION MAP	vii
REPORT	
SECTION 1 - PROJECT INFORMATION	1
SECTION 2 - ENGINEERING DATA	5
SECTION 3 - VISUAL INSPECTION	6
SECTION 4 - OPERATING PROCEDURES	8
SECTION 5 - HYDRAULIC/HYDROLOGIC	9
SECTION 6 - STRUCTURAL STABILITY	11
SECTION 7 - ASSESSMENT, RECOMMENDATIONS AND REMEDIAL MEASURES	12
APPENDIX A - VISUAL INSPECTION CHECKLIST	
APPENDIX B - EXISTING RECORDS	
APPENDIX C - PHOTOGRAPHS	
APPENDIX D - HYDRAULIC COMPUTATIONS	
APPENDIX E - INVENTORY FORMS	



OVERVIEW PHOTO

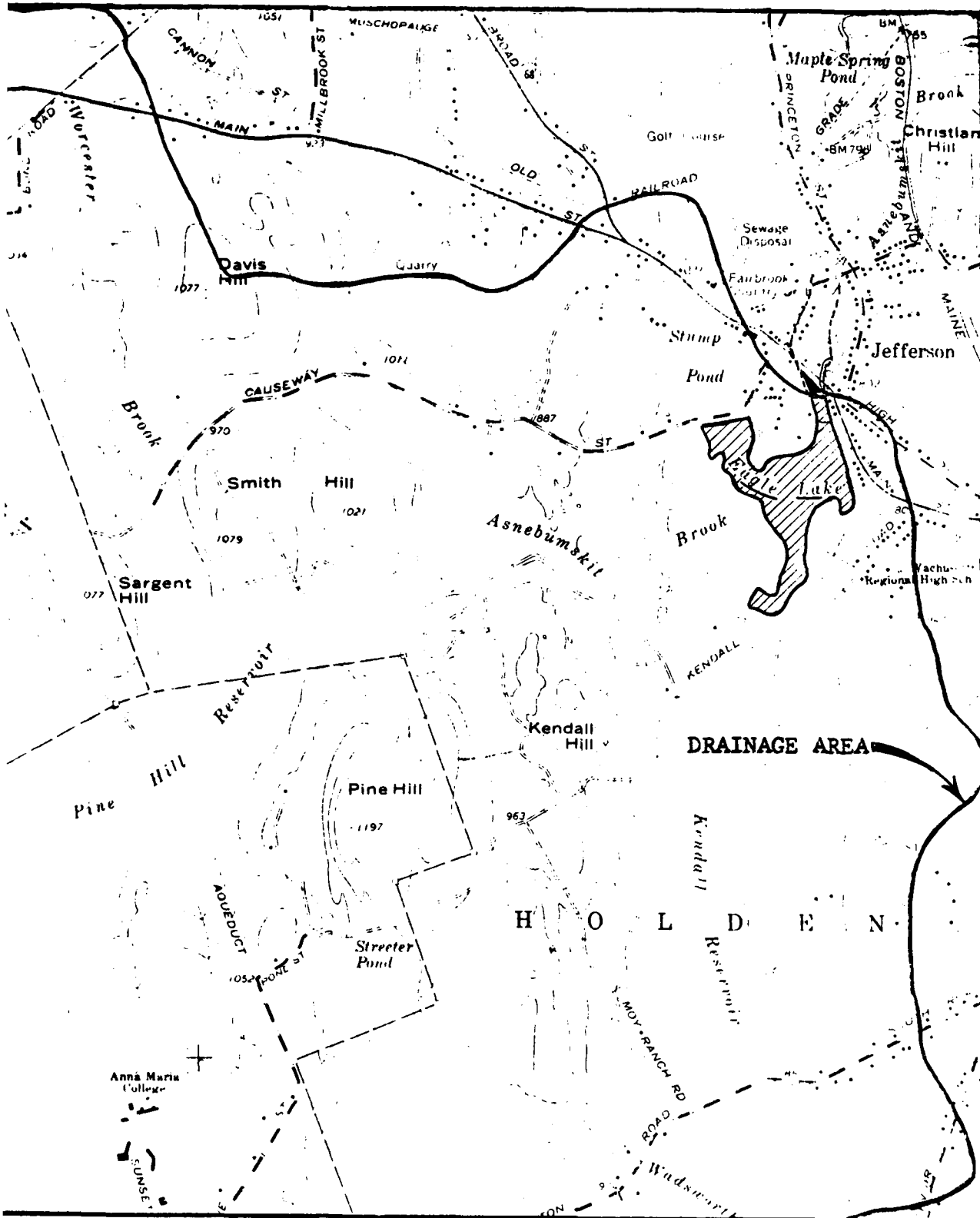

EAGLE LAKE DAM

PAXTON, MASS.
Scale 1:24000

PHASE I INSPECTION REPORT

EAGLE LAKE DAM

SECTION I

PROJECT INFORMATION

1.1 General

a. Authority. Public Law 92-367, August 8, 1972, authorized the Secretary of the Army, through the Corps of Engineers, to initiate a National Program of Dam Inspection throughout the United States. The New England Division of the Corps of Engineers has been assigned the responsibility of supervising the inspection of dams within the New England Region. Chas. T. Main, Inc. has been retained by the New England Division to inspect and report on selected dams in the State of Massachusetts. Authorization and notice to proceed were issued to Chas. T. Main, Inc. under a letter of May 3, 1978, from Ralph T. Garver, Colonel, Corps of Engineers. Contract No. DACW33-78-D328 has been assigned by the Corps of Engineers for this work.

b. Purpose.

(1) Perform technical inspection and evaluation of non-Federal dams to identify conditions which threaten the public safety and thus permit correction in a timely manner by non-Federal interests.

(2) Encourage and prepare the states to initiate quickly effective dam safety programs for non-Federal dams.

(3) To update, verify and complete the National Inventory of Dams.

1.2 Description of Project

a. Location. Eagle Lake Dam, on the Asnebumskit Brook, is located in the Town of Holden, Worcester County, Massachusetts.

b. Description of Dam and Appurtenances. The concrete section of the dam is divided into 3 ogee spillway bays, each 22 feet long. The spillway crest is about 10 feet below the top of the dam. The maximum height of the structure is about 20 feet. The abutments are earthfill behind concrete walls. It is not possible to determine exactly where the fill sections end and the natural abutments begin. The effective

VISUAL INSPECTION CHECK LIST
PARTY ORGANIZATION

JECT Eagle Lake Dam

DATE JUNE 13, 1978

TIME 2:00 P.M.

WEATHER SUNNY & CLEAR

W.S. ELEV. 777 U.S. _____ DN.S

TY:

J. Goodrich

D. Fischer

L. Cross

PROJECT FEATURE

INSPECTED BY

REMARKS

1

APPENDIX A

(4) The sluice gates and stoplogs should be tested for operability on an annual basis.

(5) Around the clock surveillance should be provided by the owner during periods of unusually heavy precipitation.

(6) Development of a formal warning system with local officials for alerting downstream residents in case of emergency. The operation of Eagle Lake should be closely coordinated with the operation of the upstream reservoirs.

SECTION 7

ASSESSMENT, RECOMMENDATIONS AND REMEDIAL MEASURES

7.1 Dam Assessment

a. Condition. The Eagle Lake Dam is considered to be in only fair condition.

b. Adequacy of Information. The lack of in-depth engineering data did not allow for a definitive review. Therefore, the adequacy of this dam could not be assessed from the standpoint of reviewing design and construction data, but is based primarily on visual inspection, past performance history, and engineering judgment.

c. Urgency. The required repair and maintenance work should be accomplished within one year of the receipt of this report by the owner.

d. Need for Additional Investigation. There is no need for additional investigation.

7.2 Recommendations

Additional engineering investigations or major modifications to the dam are not required.

7.3 Remedial Measures

a. Alternatives. Not applicable.

b. Operation and Maintenance Procedures. The owner of the dam should develop and implement procedures which would include:

(1) Continue periodic inspection on an annual frequency and the initiation of repairs, as required.

(2) Spalled concrete should be patched and cracks in the concrete cleaned and repaired.

(3) Growth should be removed from the spillway structure, and debris removed from the downstream channel as far as the Main Street bridge.

SECTION 6
STRUCTURAL STABILITY

6.1 Evaluation of Structural Stability

a. Visual Observations. Nothing was noted which would indicate that the dam is unstable.

b. Design and Construction Data. No design nor construction data are known to exist.

c. Operating Records. Not applicable.

d. Post Construction Changes. No data concerning any post construction changes are known to exist.

e. Seismic Stability. The dam is located in Seismic Zone 2 and in accordance with recommended Phase I guidelines does not warrant seismic analysis.

Depending where the breach occurred, any or all of the following could take place:

The small channel under the building immediately downstream of the spillway could not cope with the discharge; the water would rise up against the upstream face of the building and probably wash it away. The building just downstream of the right abutment would probably be an early casualty. Water would run into the streets of Jefferson. The flow over the left abutment would flow around the buildings, possibly damaging or destroying them, and eventually find its way back into the channel which is under the Main Street bridge. Between the Main Street and Princeton Street bridges, the water level would drop considerably. However, the low-lying houses in this area would be subjected to flooding, if not to damage or destruction.

The areas of impact immediately below the dam are shown on the location map.

The reservoirs within the drainage area were considered to be full at the onset of the PMF and not able to reduce the flow at Eagle Lake Dam. It should be noted, however, that inflows to Eagle Lake are highly dependent on the regulated or spillage outflows from Pine Hill Reservoir and Kendall Reservoir, two large upstream reservoirs within the watershed. A detailed hydrologic analysis of Eagle Lake could not be performed without including the analysis of these two other projects. The possible effects of these two reservoirs was not considered in this cursory study.

SECTION 5

HYDRAULIC/HYDROLOGIC

5.1 Evaluation of Features

a. Design Data. The hydraulic/hydrologic analysis was made in accordance with "Preliminary Guidance for Estimating Maximum Probable Discharges in Phase I Dam Safety Investigations", "Estimating Effect of Surchage Storage on Maximum Probable Discharges", and "Rule of Thumb Guidance for Estimating Downstream Dam Failure Hydrographs" as furnished by the New England Division, Corps of Engineers and "Recommended Guidelines for Safety Inspection of Dams" as issued by the Department of the Army, Office of the Chief of Engineers.

U.S.G.S. Quadrangle maps were used to determine reservoir and drainage areas. Where practicable, spillway dimensions were obtained by direct measurement. Hydraulic coefficients were assigned on the basis of experience and engineering judgment.

b. Experience Data. No specific experience data with respect to the hydraulic/hydrological characteristics of the project are known to exist.

c. Visual Observations. Space between top of stoplogs (and gates) and underside of bridge could plug easily. Some growth and debris was noted on the downstream side of the structure. Overflow of the right abutment would flow onto Main Street.

d. Overtopping Potential. A Probable Maximum Flood (PMF) of 16,800 cfs was determined. Although in the small size classification, there is a high hazard potential associated with the project and the PMF was used in the determination of the Peak Outflow (or test flood) of 16,000 cfs.

The situation was analyzed first by assuming that the stoplogs were removed and the sluice gate open. In this case the spillway could discharge about 5,000 cfs, the remaining 11,000 cfs discharging over the bridge and abutments. The surcharge would be about 6 feet. A second analysis was made, assuming that the less than 2-foot opening between the top of the stoplogs and sluice gates were plugged and the entire test flood would discharge over the bridge and abutments. The surcharge thus created would be between 8 and 9 feet.

By assuming a breach of 100 feet in the dam, with the spillway plugged and water to the top of the dam, a Peak Failure Outflow of 15,000 cfs was determined. Thus the PFO and the test flood can be considered about equal.

SECTION 4
OPERATIONAL PROCEDURES

4.1 Procedures

Other than to keep the water level constant by means of stoplogs and sluice gates, there are no operating procedures.

4.2 Maintenance of Dam

There appear to be no definite maintenance procedures of the dam in effect.

4.3 Maintenance of Operating Facilities

Stoplogs are apparently repaired or replaced as required. The operability of the sluice gates is questionable.

4.4 Warning System

There is no warning system.

4.5 Evaluation

Apart from keeping the water level constant, and minimal maintenance, there appear to be no operational procedures. Recommendations for improving these conditions are given in Section 7.3.

able. The reservoir itself is not a factor in evaluating the dam. The channel immediately downstream appears inadequate to safely carry major flows and there is obvious jeopardy to property and life in the event of a significant failure of the dam.

SECTION 3

VISUAL INSPECTION

3.1 Findings

a. General. The Phase I visual inspection of the Eagle Lake Dam was conducted on June 13, 1978. The relatively low concrete spillway section has earth fill abutments which are difficult to distinguish accurately from the original natural grade. While the area seems to be acceptably maintained, the fact that industrial buildings immediately downstream of the dam, and Main Street, too, would be flooded in the event the dam was overtopped, overshadows other visual impressions.

b. Dam. There are stoplogs in two of the spillway bays, and four sluice gates in the third. These keep the pond level constant. The clear space between this level and the underside of the bridge across the spillway amounts to something less than two feet. There is spalling and some cracking on the spillway surface. There are no obvious horizontal or vertical misalignments. The spillway and abutment sections appear to be in fair condition. The operability of the sluice gates is questionable as owner indicates they have not been used within the memory of those presently responsible for the dam.

c. Appurtenant Structures. The only observable appurtenant structure is a closed and abandoned inlet to what was once a mill building adjacent to the right abutment. This structure appears sound and is of no consequence.

d. Reservoir Area. This is a small reservoir with no structures near the periphery. There is a small bathing beach. The banks are gently sloping and there is no possibility of landslides or other sudden increase of sediment load in the reservoir.

e. Downstream Channel. The spillway discharges directly under an industrial building, runs through a narrow channel between other industrial buildings, and under a highway bridge before discharging into a natural watercourse. There are several homes on the banks of this watercourse.

3.2 Evaluation

Based on visual inspection, the concrete structure appears to be structurally sound but poorly maintained. While the project is in fair condition, the operability of the stoplogs and sluice gates, which could be a significant feature in mitigating downstream effects, is question-

SECTION 2
ENGINEERING DATA

2.1 Design

No design data are known to exist.

2.2 Construction

The Eagle Lake Dam was built in 1925. There are no detailed construction records available.

2.3 Operation

There is no formal operation of the dam. The fixed spillway crest controls the water level of the reservoir.

2.4 Evaluation

- a. Availability. There are no engineering data available.
- b. Adequacy. The lack of in-depth engineering data does not allow for a definitive review. Therefore, the adequacy of this dam, structurally and hydraulically, cannot be assessed from the standpoint of review of design calculations, but must be based primarily on the visual inspection, past performance history, and sound hydrologic and hydraulic engineering judgment.
- c. Validity. N/A

g. Dam

(1) Type	Concrete ogee section
(2) Length	66 \pm feet
(3) Height	20 \pm feet
(4) Top Width	N/A
(5) Side slope	N/A
(6) Zoning	N/A
(7) Impervious core	N/A
(8) Cutoff	Unknown
(9) Grout curtain	Unknown
(10) Other	N/A

h. Spillway

(1) Type	Ogee
(2) Length of weir	66 \pm feet gross
(3) Crest elevation	El. 770 \pm
(4) Gates	4 wood sluice gates
(5) U/S Channel	N/A
(6) D/S Channel	Discharges under a mill building
(7) General	N/A

i. Regulating Outlets. There are 4 wood sluice gates, about 6 feet high, within a 22-foot wide spillway bay. It is not known if these gates are operable. In the 2 adjoining 22-foot bays, there are wood stoplogs, about 6 feet high.

There was formerly a 24 or 30-inch line leading to an industrial building on the right abutment. This line has been permanently capped.

c. Elevation (Feet Above MSL)

(1)	Top of dam	E1. 780 ±
(2)	Maximum design surcharge	E1. 780 ±
(3)	Full flood control pool	N/A
(4)	Recreation pool	E1. 777 ±
(5)	Spillway crest (gated)	E1. 770 ±
(6)	Upstream portal invert diversion tunnel	N/A
(7)	Streambed at centerline of dam	E1. 760 ±
(8)	Maximum tailwater	N/A

d. Reservoir (Feet)

(1)	Length of maximum pool	3,000 ±
(2)	Length of recreation pool	3,000 ±
(3)	Length of flood control pool	N/A

e. Storage (Acre-Feet)

(1)	Recreation pool	680 ±
(2)	Flood control pool	N/A
(3)	Design surcharge	800 ±
(4)	Top of dam	800 ±

f. Reservoir Surface (Acres)

(1)	Top of dam	102 ±
(2)	Maximum pool	102 ±
(3)	Flood control pool	N/A
(4)	Recreation pool	80 ±
(5)	Spillway crest	

hydraulic lengths of the abutments were assumed to be 125 and 75 feet for the left and right banks, respectively. There are 4 slide gates in one spillway bay, stoplogs in the other two.

c. Size Classification. Owing to its height of 20 feet and its impoundment of 800 acre feet, the dam falls within the small size classification.

d. Hazard Classification. As there are industrial buildings and dwellings immediately downstream of the dam which would be endangered if the dam failed, the dam is considered to have a high hazard potential.

e. Ownership. The dam is owned by Jefferson Industries located at 113 Main Street, Holden, Massachusetts.

f. Operator. Mr. Paul Desroches, 1665 North Main Street, Jefferson, Massachusetts. Telephone: (617) 829-5644.

g. Purpose of Dam. The dam has been used in the past to supply water to a woolen spinning mill. It has no present usage other than it provides a bathing beach for the town.

h. Design and Construction History. Other than it was constructed in 1925, nothing is known of the design and construction history of the dam.

i. Operating Procedures. The stoplogs are kept in place to maintain the lake level for recreation. There is general maintenance and cleanup. In times of high flow, the stoplogs and gates would have to be raised manually.

1.3 Pertinent Data

a. Drainage Area. This dam has a drainage area of about 6,500 acres of primarily low, wooded hills. There are two other reservoirs and two small ponds within the drainage area.

b. Discharge at Damsite.

(1) There is a closed and abandoned inlet to what was apparently a mill building on the right bank near the dam.

(2) The maximum flood at the damsite is unknown.

(3) The ungated spillway capacity at maximum pool El. 780 is about 4,000 cfs.

(4) Not applicable.

(5) The gate spillway capacity at maximum pool Elev. 780 is about 1,000 cfs.

(6) The total spillway capacity at maximum pool El. 780 is about 5,000 cfs.

INSPECTION CHECK LIST

PROJECT EAGLE LAKE DAM

DATE 6/13/78

PROJECT FEATURE _____

NAME _____

AREA EVALUATED	CONDITION
<p><u>DIKE EMBANKMENT</u></p> <p>Crest Elevation</p> <p>Current Pool Elevation</p> <p>Surface Cracks</p> <p>Pavement Condition</p> <p>Movement of Settlement of Crest</p> <p>Lateral Movement</p> <p>Vertical Alignment</p> <p>Horizontal Alignment</p> <p>Condition at Abutment and at Concrete Structures</p> <p>Indications of Movement of Structural Items on Slopes</p> <p>Trespassing on Slopes</p> <p>Sloughing or Erosion of Slopes or Abutments</p> <p>Rock Slope Protection - Riprap Failures</p> <p>Unusual Movement or Cracking at or near Toes</p> <p>Unusual Embankment or Downstream Seepage</p> <p>Piping or Boils</p> <p>Foundation Drainage Features</p> <p>Toe Drains</p> <p>Instruments on System</p>	<p style="text-align: center;">NOT APPLICABLE</p>

INSPECTION CHECK LIST

PROJECT EAGLE LAKE DAM

DATE 6/13/78

PROJECT FEATURE _____

NAME _____

AREA EVALUATED	CONDITION
<p><u>CONCRETE DAM</u></p> <p>Concrete Surfaces</p> <p>Structural Cracking</p> <p>Movement -- Horizontal & Vertical Alignment</p> <p>Junctions</p> <p>Drains -- Foundation, Joint, Face</p> <p>Water Passages</p> <p>Seepage or Leakage</p> <p>Monolith Joints -- Construction Joints</p> <p>Foundation</p>	<p><i>Major spalling and abrasion</i></p> <p><i>some cracking</i></p> <p><i>none noticable</i></p> <p><i>none</i></p> <p><i>Leakage through flashboards</i></p> <p style="text-align: right;">3</p>

INSPECTION CHECK LIST

PROJECT EAGLE LAKE DAM

DATE 6/13/78

PROJECT FEATURE _____

NAME _____

AREA EVALUATED	CONDITION
<p><u>OUTLET WORKS - INTAKE CHANNEL AND INTAKE STRUCTURE</u></p> <p>a. Approach Channel</p> <p> Slope Conditions</p> <p> Bottom Conditions</p> <p> Rock Slides or Falls</p> <p> Log Boom</p> <p> Debris</p> <p> Condition of Concrete Lining</p> <p> Drains or Weep Holes</p> <p>b. Intake Structure</p> <p> Condition of Concrete</p> <p> Stop Logs and Slots</p>	<p><i>NOT APPLICABLE</i></p> <p>4</p>

INSPECTION CHECK LIST

PROJECT EAGLE LAKE DAM

DATE 6/13/78

PROJECT FEATURE _____

NAME _____

AREA EVALUATED	CONDITION
<p><u>OUTLET WORKS - TRANSITION AND CONDUIT</u></p> <p>General Condition of Concrete</p> <p>Rust or Staining on Concrete</p> <p>Spalling</p> <p>Erosion or Cavitation</p> <p>Cracking</p> <p>Alignment of Monoliths</p> <p>Alignment of Joints</p> <p>Numbering of Monoliths</p>	<p>NOT APPLICABLE</p>

INSPECTION CHECK LIST

PROJECT EAGLE LAKE DAM

DATE 6/13/78

PROJECT FEATURE _____

NAME _____

AREA EVALUATED	CONDITION
<u>OUTLET WORKS - SPILLWAY WEIR, APPROACH AND DISCHARGE CHANNELS</u>	
<p>a. Approach Channel</p> <p>General Condition</p> <p>Loose Rock Overhanging Channel</p> <p>Trees Overhanging Channel</p> <p>Floor of Approach Channel</p>	<p><i>o.k.</i></p> <p><i>None</i></p> <p><i>None</i></p>
<p>b. Weir and Training Walls</p> <p>General Condition of Concrete</p> <p>Rust or Staining</p> <p>Spalling</p> <p>Any Visible Reinforcing</p> <p>Any Seepage or Efflorescence</p> <p>Drain Holes</p>	<p><i>fair</i></p> <p><i>major spalling</i></p> <p><i>none</i></p> <p><i>none</i></p> <p><i>-</i></p>
<p>c. Discharge Channel</p> <p>General Condition</p> <p>Loose Rock Overhanging Channel</p> <p>Trees Overhanging Channel</p> <p>Floor of Channel</p> <p>Other Obstructions</p>	<p><i>None</i></p> <p><i>None</i></p> <p><i>spalling of concrete</i></p> <p><i>Debris and vegetation</i></p>

INSPECTION CHECK LIST

PROJECT EAGLE LAKE DAM

DATE 6/13/78

PROJECT FEATURE _____

NAME _____

AREA EVALUATED	CONDITION
<p><u>OUTLET WORKS - CONTROL TOWER</u></p> <p>a. Concrete and Structural</p> <p> General Condition</p> <p> Condition of Joints</p> <p> Spalling</p> <p> Visible Reinforcing</p> <p> Rusting or Staining of Concrete</p> <p> Any Seepage or Efflorescence</p> <p> Joint Alignment</p> <p> Unusual Seepage or Leaks in Gate Chamber</p> <p> Cracks</p> <p> Rusting or Corrosion of Steel</p> <p>b. Mechanical and Electrical</p> <p> Air Vents</p> <p> Float Wells</p> <p> Crane Hoist</p> <p> Elevator</p> <p> Hydraulic System</p> <p> Service Gates</p> <p> Emergency Gates</p> <p> Lightning Protection System</p> <p> Emergency Power System</p> <p> Wiring and Lighting System</p>	<p style="text-align: center;"><i>NOT APPLICABLE</i></p>

INSPECTION CHECK LIST

PROJECT EAGLE LAKE DAM

DATE 6/13/78

PROJECT FEATURE _____

NAME _____

AREA EVALUATED	CONDITION
<p><u>OUTLET WORKS - OUTLET STRUCTURE AND OUTLET CHANNEL</u></p> <p>General Condition of Concrete</p> <p>Rust or Staining</p> <p>Spalling</p> <p>Erosion or Cavitation</p> <p>Visible Reinforcing</p> <p>Any Seepage or Efflorescence</p> <p>Condition at Joints</p> <p>Drain holes</p> <p>Channel</p> <p>Loose Rock or Trees Overhanging Channel</p> <p>Condition of Discharge Channel</p>	<p style="text-align: center;"><i>NOT APPLICABLE</i></p>

APPENDIX B

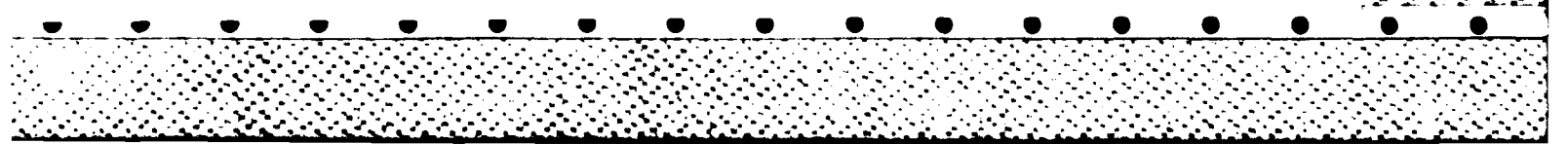
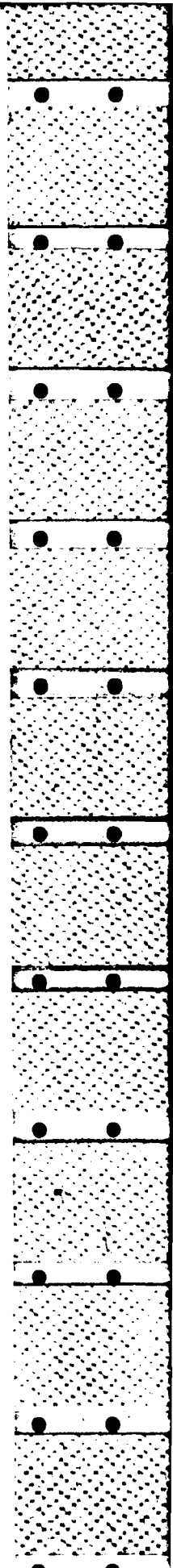

No records of the design and construction
of this project were located.

APPENDIX C

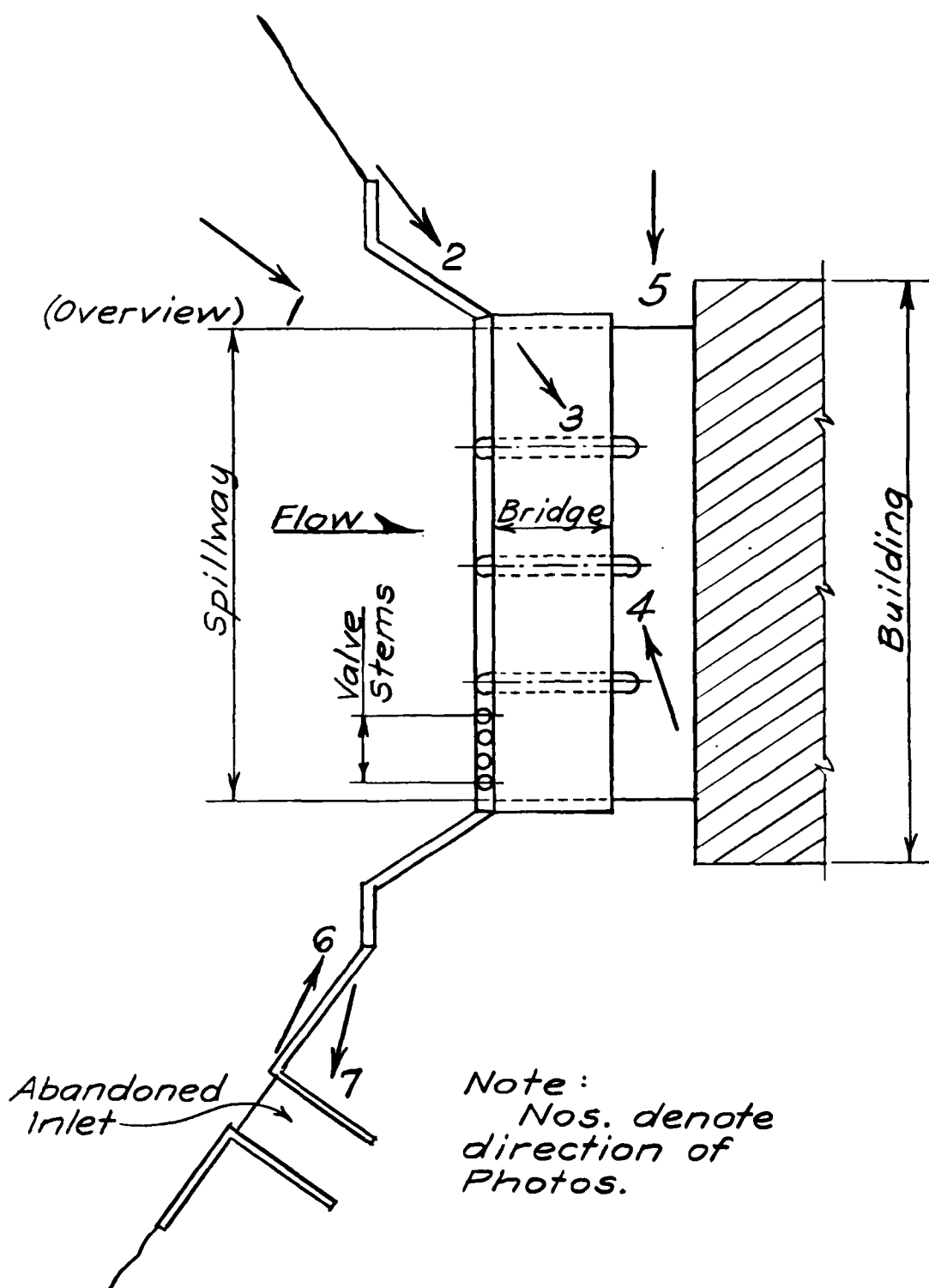

Note:
Nos. denote
direction of
Photos.

PLAN
EAGLE LAKE DAM

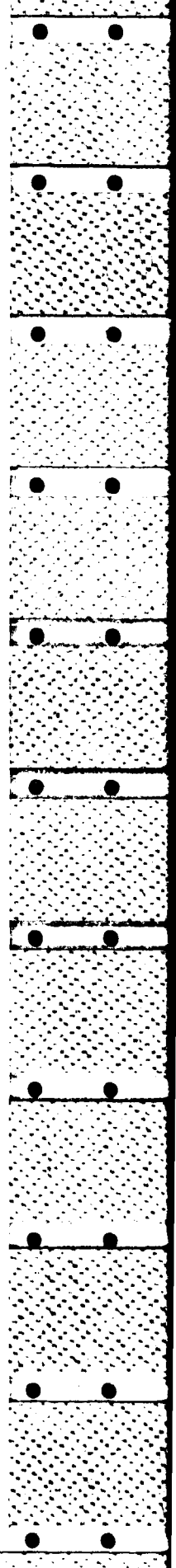

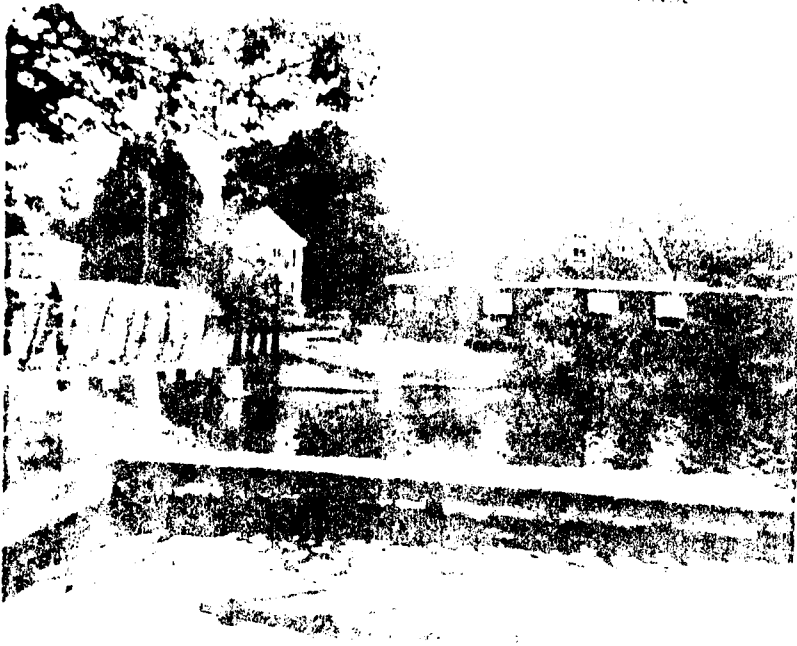

2

Upstream View of Dam from Left Bank



3

Downstream View of Spillway from Bridge

EAGLE LAKE DAM

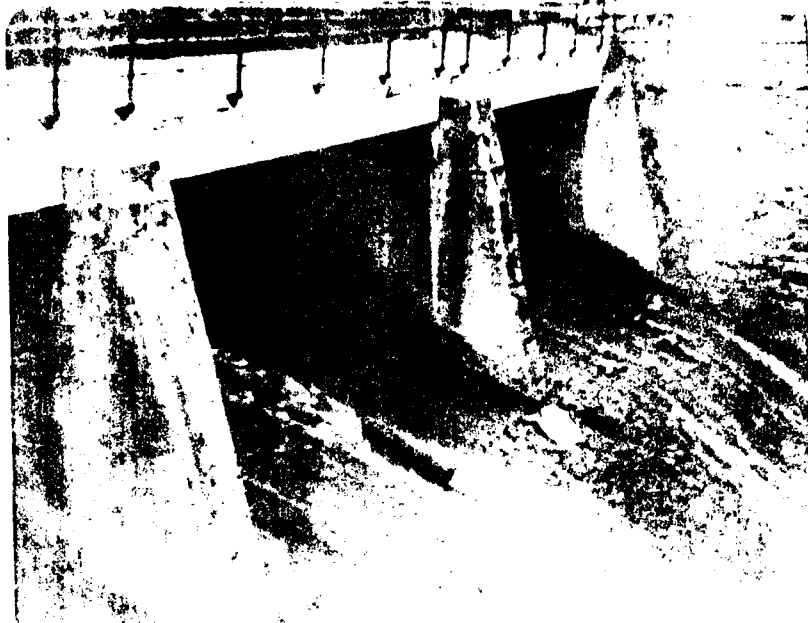

4

Downstream View of Spillway
from Right Bank



5

Downstream View of Spillway
from Left Bank

EAGLE LAKE DAM



Upstream View of Spillway from Right Bank



Abandoned Inlet to Mill Building

APPENDIX D

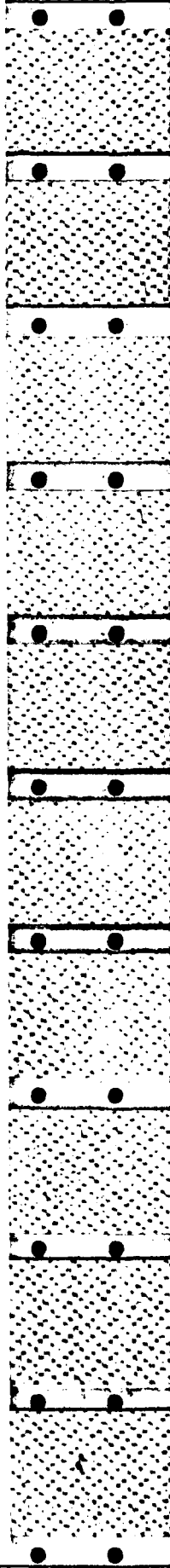
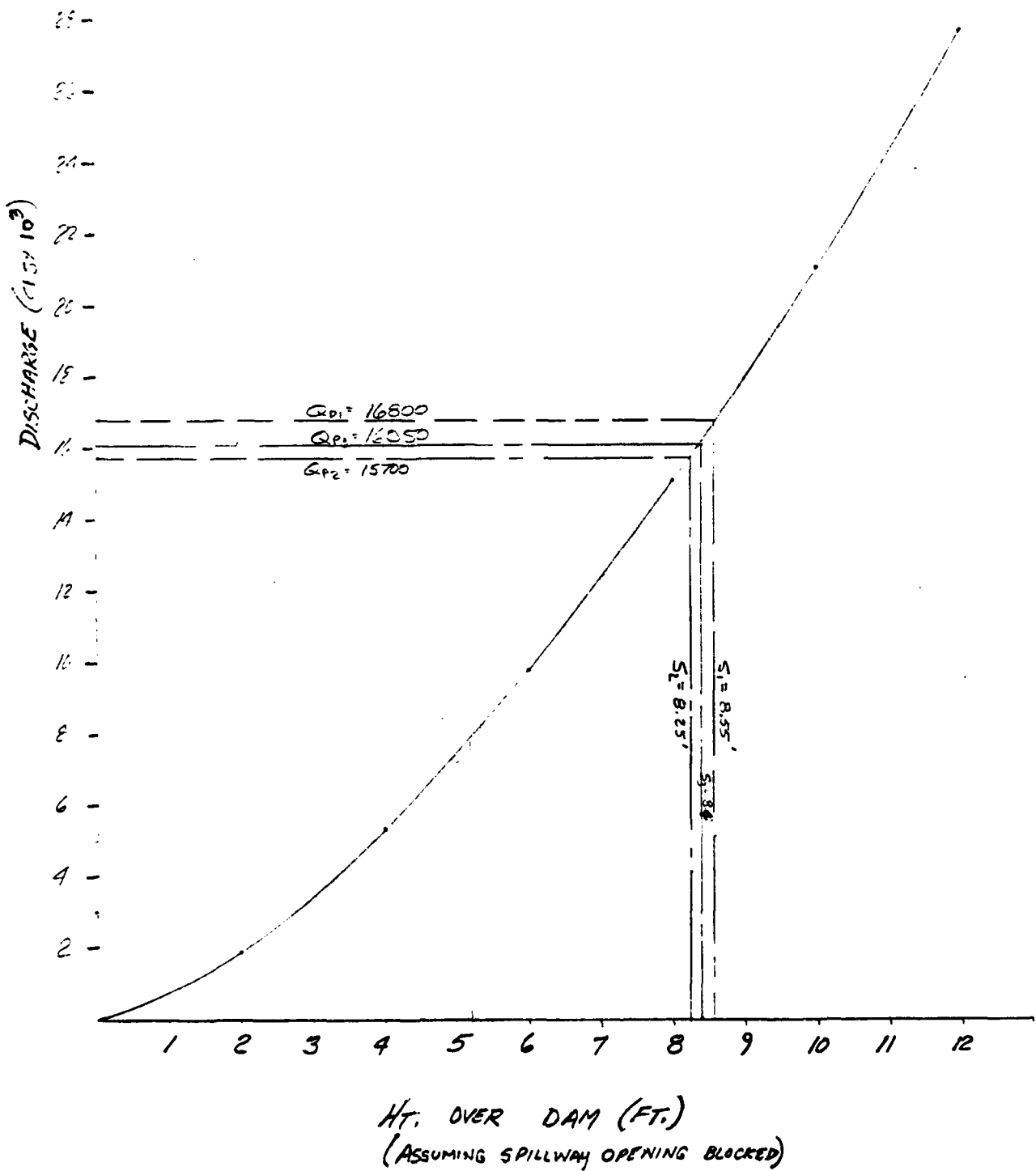

Client C&E

Job No. 1345065 Sheet 3 of 11

Subject LAKE CREEK

By J. VETTER Date 22 July 1975

Ckd. _____ Rev. _____

$$S_1 = 5.55'$$

$$STOR_1 = \frac{5.55'(12)(50)}{6565} = 1.25''$$

$$Q_{12} = 15700 \left(1 - \frac{1.25}{79}\right) = 15700 \text{ cfs.}$$

$$S_2 = 5.25'$$

$$STOR_2 = \frac{5.25'(12)(50)}{6565} = 1.21''$$

$$Ave = 1.23''$$

$$S = \frac{1.23''(6565)}{(12)(50)} = 3.1'$$

$$Q_{12} = 16,250 \text{ cfs.}$$

WATER ELEVATION @ 5.9' OVER DAM CREST = 788.4'

HAND HOMES AROUND LAKE SHORE - EXTENSIVE PROPERTY DAMAGE.

RIDGE DOWNSTREAM

CHANNEL UNDER FACTOR SMALLEST CROSS SECTION ~ 18' x 6'

$$Q = \frac{1.49}{n} A R^{2/3} S^{1/2}$$

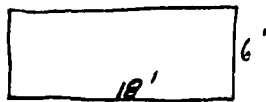

$$n = .03$$

$$S_{\text{ASSUME}} = \text{CHANNEL SCOPE} = (.01)$$

$$A = 108 \text{ FT}^2$$

$$WR = 30 \quad R^{2/3} = 2.35$$

$$Q = \frac{1.49}{.03} (108)(2.35)(0.01)^{1/2}$$

$$\approx 1260 \text{ CFS} \quad 8\% \text{ PEAK FLOW } \checkmark \text{ NEGLECT.}$$

Client CORP INC.

Job No. 1345-065 Sheet 4 of 11

Subject EAGLE LAKE

By L. VENTURA Date 20-10-4-1978

Ckd. _____ Rev. _____

Section #1 2+00 L.D.
#1

1" = 400' →
1" = 20' ↓

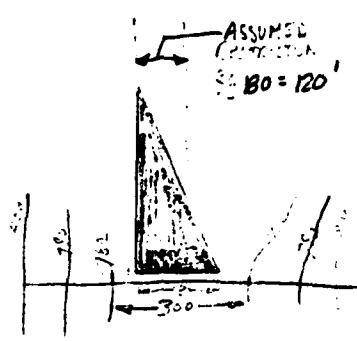
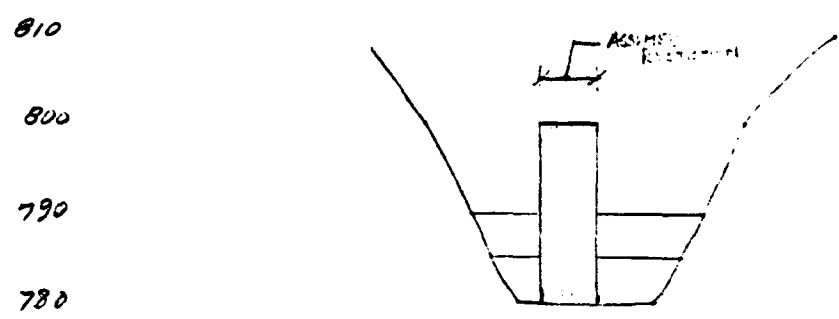

Section #2 4+00

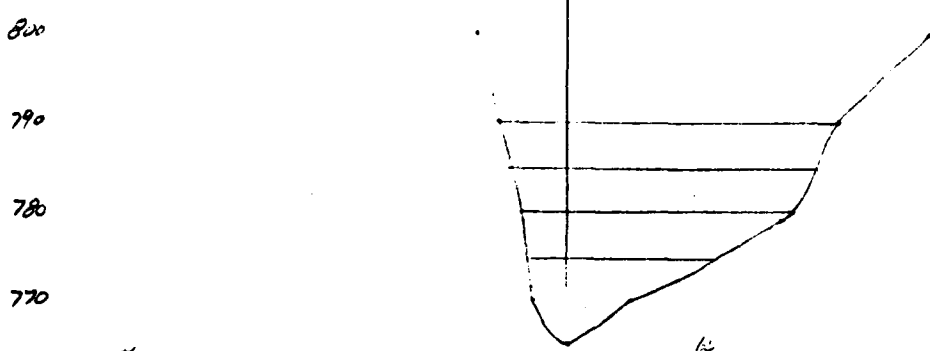

Section #3 13+00

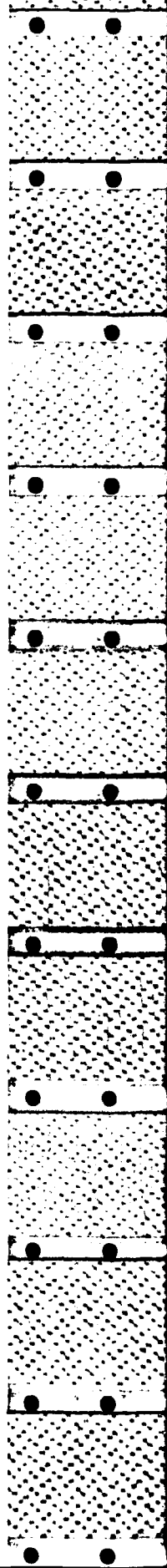
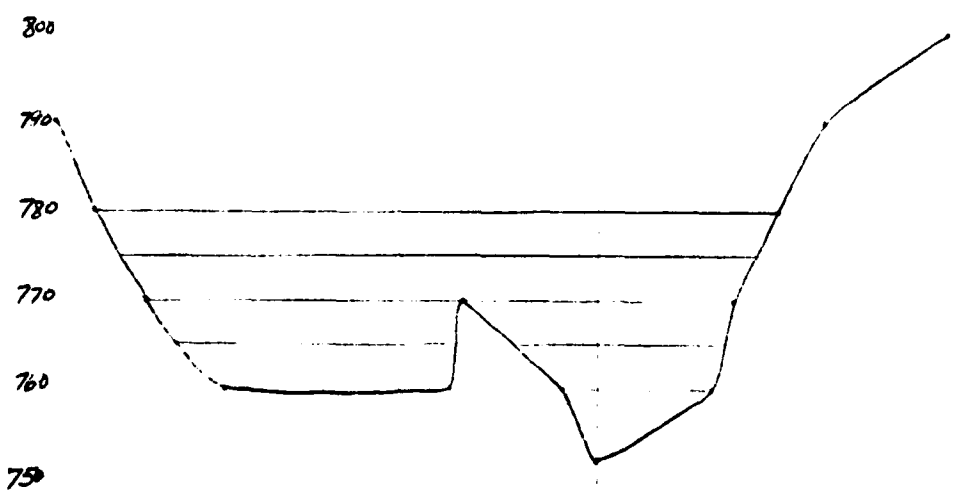

Client C of FJob No. 1345-065 Sheet 5 of 11Subject ENGINE WORKBy J. VEITCHDate 26 JUL 1973

Ckd. _____

Rev. _____

STORAGE @ FAILURE $80(20) \cdot 5 = 800 \text{ AC FT.}$

$$Q_{P1} = \frac{8}{27} W_b \sqrt{g} Y_o^{3/2}$$

$$= \frac{8}{27} (100) \sqrt{32.2} (20.0)^{1.5} = 15,040 \text{ CFS.} + 1880 (\text{SPILLWAY CAPACITY}) = 16920 \text{ c}$$

$Y_o = 20.0'$
 $W_b = 100.0'$

 \therefore CRITICAL CASE: PEAK FAILURE OUTFLOW: 16920 cfs EL. 780.5 Reach

$$V_1 = \frac{15.5}{15} \frac{(2325) 900}{43560} = 22 \text{ AC FT.}$$

$$Q_{P2} (\text{TRIAL}) = 16920 \left(1 - \frac{22}{800}\right) = 16,455 \text{ cfs. } \underline{\text{NELECT V}_1}$$

Reach II 16,920 EL. 762.7

$$V_1 = \frac{9.7}{12} \frac{3060 (900)}{43560} = 51.1 \text{ AC FT}$$

$$Q_{P2} (\text{TRIAL}) = 16920 \left(1 - \frac{51}{800}\right) = 15841 \text{ cfs. } \Rightarrow \text{EL. 762.5}$$

$$V_2 = \frac{9.5}{9.7} (51) = 49.9 \quad V_{\text{AVE}} = 50.1 \text{ AC FT}$$

$$Q_{P2} = 16920 \left(1 - \frac{50.1}{800}\right) =$$

$$= 15851 \text{ cfs}$$

LARGE FACTORY & BUILDING w/ SMALL
SHOPS & INDUSTRY UNDER WATER. LARGE
POTENTIAL OF PROPERTY DAMAGE AND SOME
HAZARD TO LIFE.

Client C of E

Job No. 1345-065 Sheet 6 of 11

Subject EARLY STAGE

By J. VEITCH Date 26 JULY 1975

Chd. _____ Rev. _____

SECTION I	A	EA	W.P.	E W.P.
780	-	-	300	300
785	1800	1800	125	425
790	2325	4125		520

II				
775	2100	2100	420	420
780	2550	4650	190	610
785	3200	7850	70	680
790	3560	11410	80	760

REACH I. $Q = CAR^{2/3} S^{1/2}$

$C=30$
 $S=.005$

EL	Q
775	$Q = 30(1050) \left(\frac{1050}{360}\right)^{2/3} \sqrt{.005} = 4550$
780	$30(2325) \left(\frac{2325}{455}\right)^{2/3} \sqrt{.005} = 14,630$
785	$30(4825) \left(\frac{4825}{550}\right)^{2/3} \sqrt{.005} = 43,540$
790	$30(7770) \left(\frac{7770}{640}\right)^{2/3} \sqrt{.005} = 87,070$

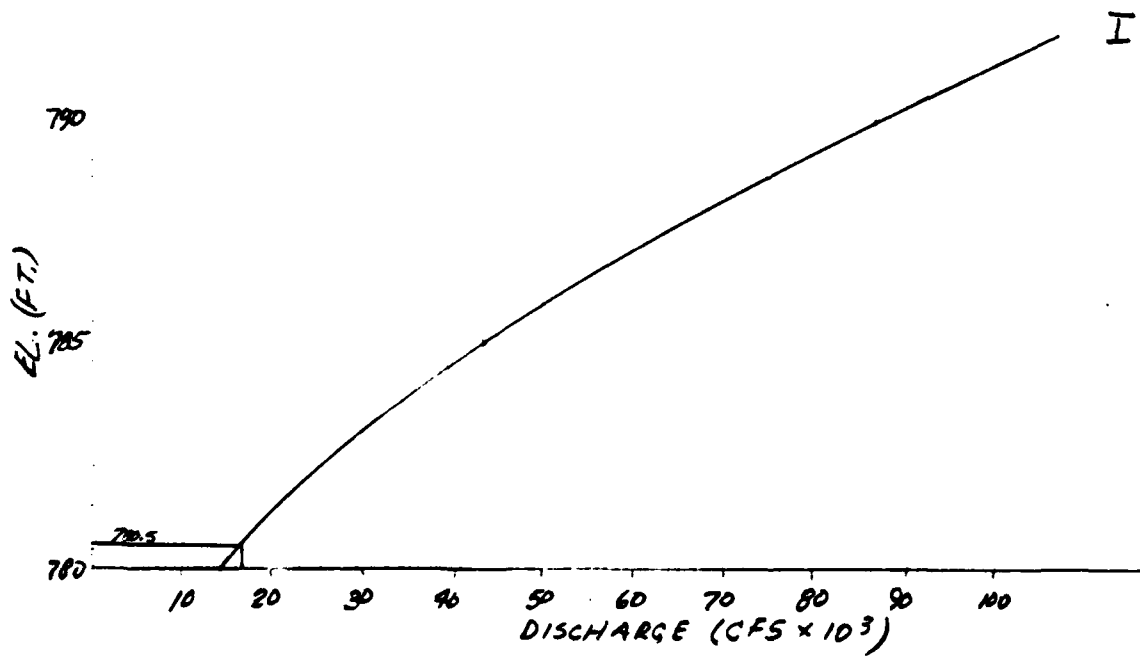

Client A. E. F.
 Subject EAGLE LAKE

Job No. 1345-065 Sheet 7 of 11
 By W. J. ... Date 27
 Ctd. _____ Rev. _____

SECTION III.	A.	Σ A	Σ WP.
760	1320	1320	330
765	4800	6120	1090
770	5950	12070	1310
775	6750	18820	1420
780	7300	26120	1520
785			

EL. 770 $Q = 30 \left(6310 \right) \left(\frac{6310}{765} \right)^{2/3} (.01)^{1/2} = 77,825$

775 $Q = 30 \left(10460 \right) \left(\frac{10460}{920} \right)^{2/3} (.01)^{1/2} = 159,960$

780 $Q = 30 \left(15385 \right) \left(\frac{15385}{1065} \right)^{2/3} (.01)^{1/2} = 276,215$

765 $Q = 30 \left(3060 \right) \left(\frac{3060}{545} \right)^{2/3} (.01)^{1/2} = 29,170$

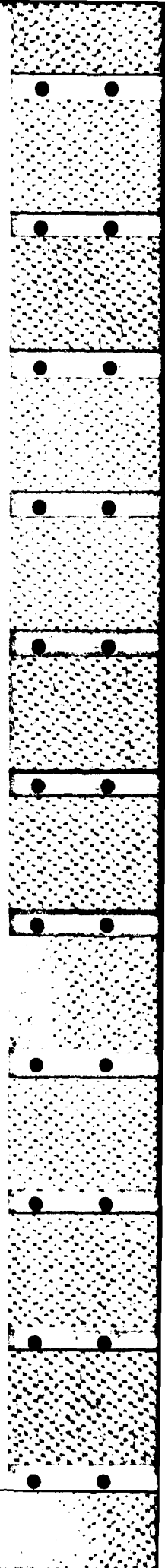
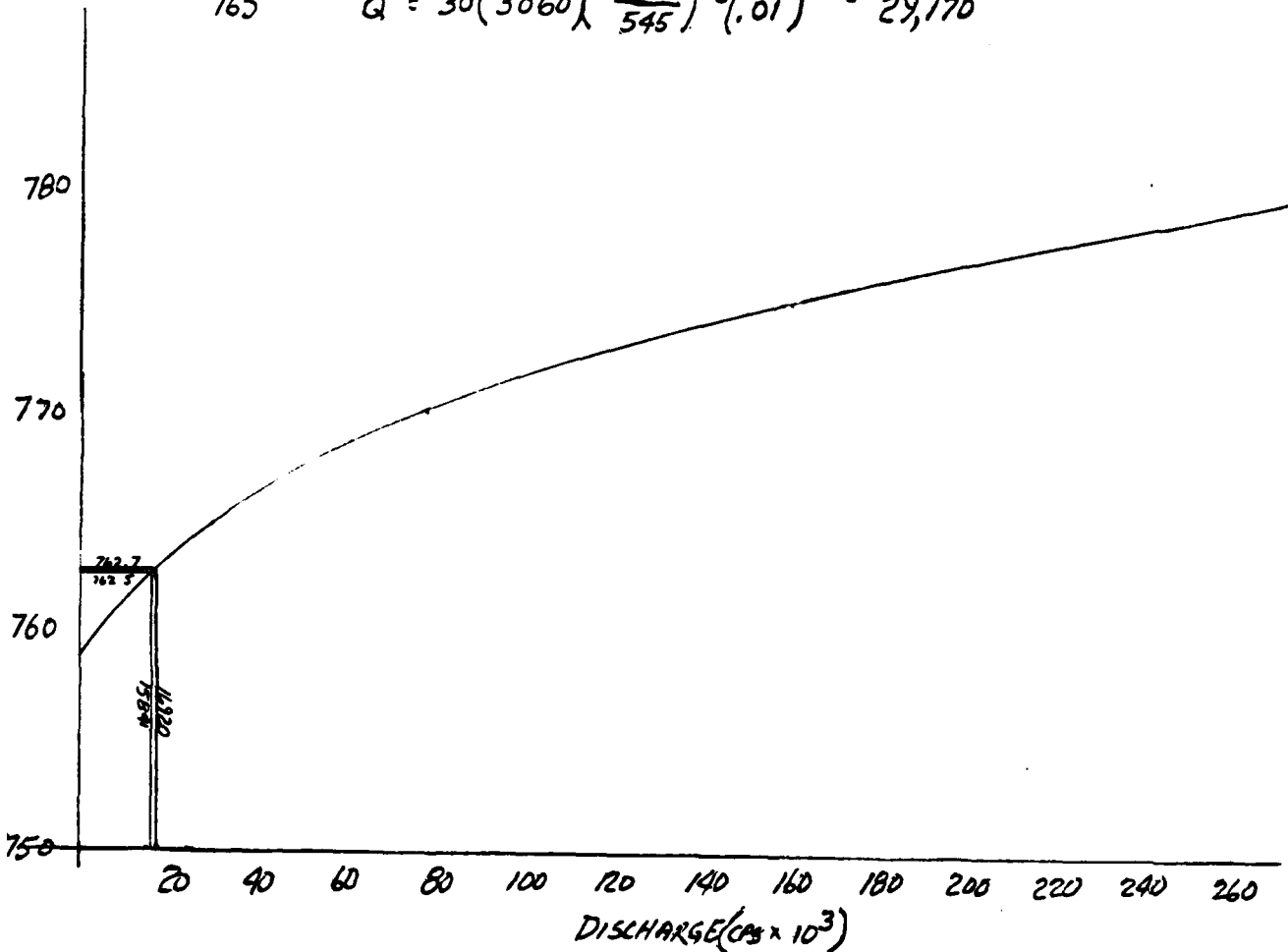

Client J OF ENS

Job No. 1345-065 Sheet B of 11

Subject EAGLE LAKE

By J. J. J. Date 27 J. 1954

Chd. _____ Rev. _____

REACH #3 Q = 15,851 EL. 758.0

$$V_1 = \frac{(13.0)(2285)(1000)}{157 \cdot 43560} = 45.5 \text{ AC FT.}$$

$$Q_{P2} \text{ (TRIAL)} = 15851 \left(1 - \frac{45.5}{800}\right) = 14,950 \text{ cfs. } \Rightarrow \text{EL. 757.9}$$

$$V_2 = \frac{12.9}{73}(45.5) = 45.2 \quad V_{ave} = 45.4 \text{ AC FT.}$$

$$Q_{P3} = 15851 \left(1 - \frac{45.4}{800}\right) = 14,951 \text{ cfs.}$$

SECTION 4.

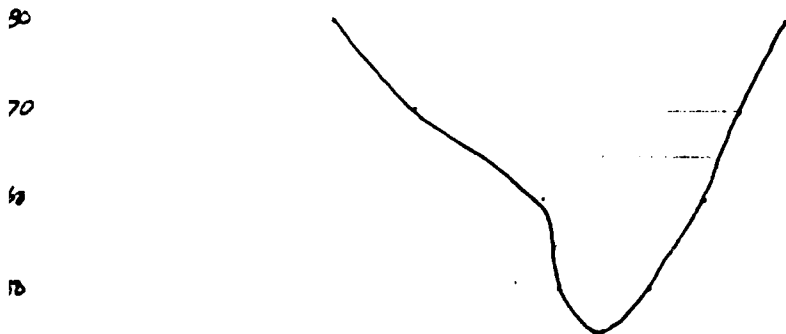

	A	ΣA	ΣWP
750	500	500	
755	1175	1675	270
760	1575	3250	360
765	2200	5450	525
770	3100	8550	720

PACH 3

$$760 \quad Q = 30 \left(2285 \right) \left(\frac{2285}{345} \right)^{2/3} (.1) = 59,800 \text{ cfs}$$

$$765 \quad Q = 30 \left(5785 \right) \left(\frac{5785}{808} \right)^{2/3} (.1) = 141,850 \text{ cfs}$$

$$770 \quad Q = 30 \left(10310 \right) \left(\frac{10310}{1015} \right)^{2/3} (.1) = 146,135 \text{ cfs}$$

$$755 \quad Q = 30 \left(840 \right) \left(\frac{840}{210} \right)^{2/3} (.1) = 6,880 \text{ cfs}$$

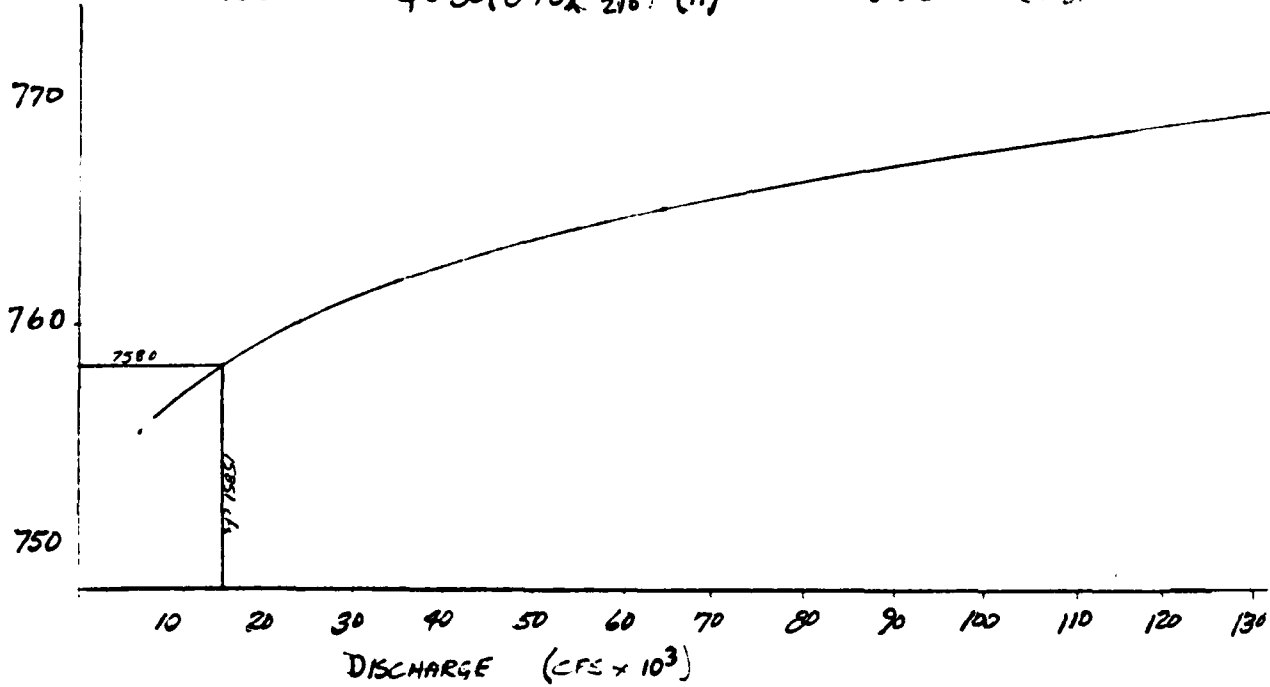

A FEW HOUSES & ROADS FLOOD IN
THIRD REACH SOME PROPERTY DAMAGE
PROBABLY OCCURING.

11 C of C
101 EAGLE LAKE

Job No. 1345-065 Sheet 10 of 11
By J. Vertch Date 22 AUG. 1978
Ckd. _____ Rev. _____

CRITICAL CASE PFO. 16920 cfs.

REACH I 16920 cfs EL. 780.5

MUCH PROPERTY DAMAGE TO FACTORY WITH HIGH HAZARD
to life.

REACH II 16920 cfs. EL. 762.5

Flooding to homes below Country Club slight hazard to
life.

REACH III 15851 cfs. EL. 758.0

Flooding to homes & streets in AREA, little hazard to
life.

EST FLOOD 16,050 : relatively equal in magnitude to the
PFO with virtually the SAME results.

C of E

Job No. 1345-065 Sheet 11 of 11

- EAGLE LAKE -

By J. VETICH Date 25 AUG 1978

CAPACITY CURVE -

Ckd. _____ Rev. _____

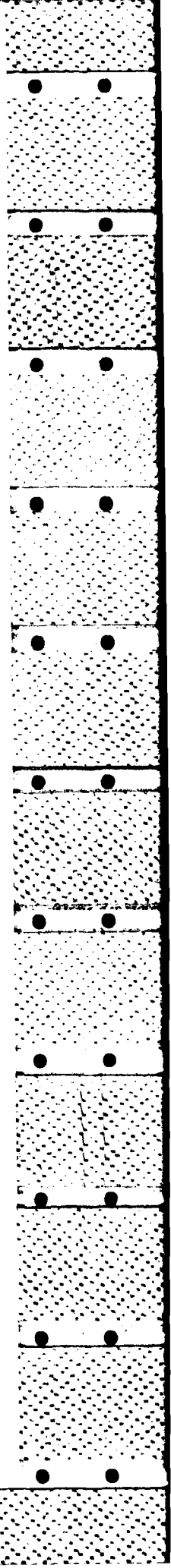
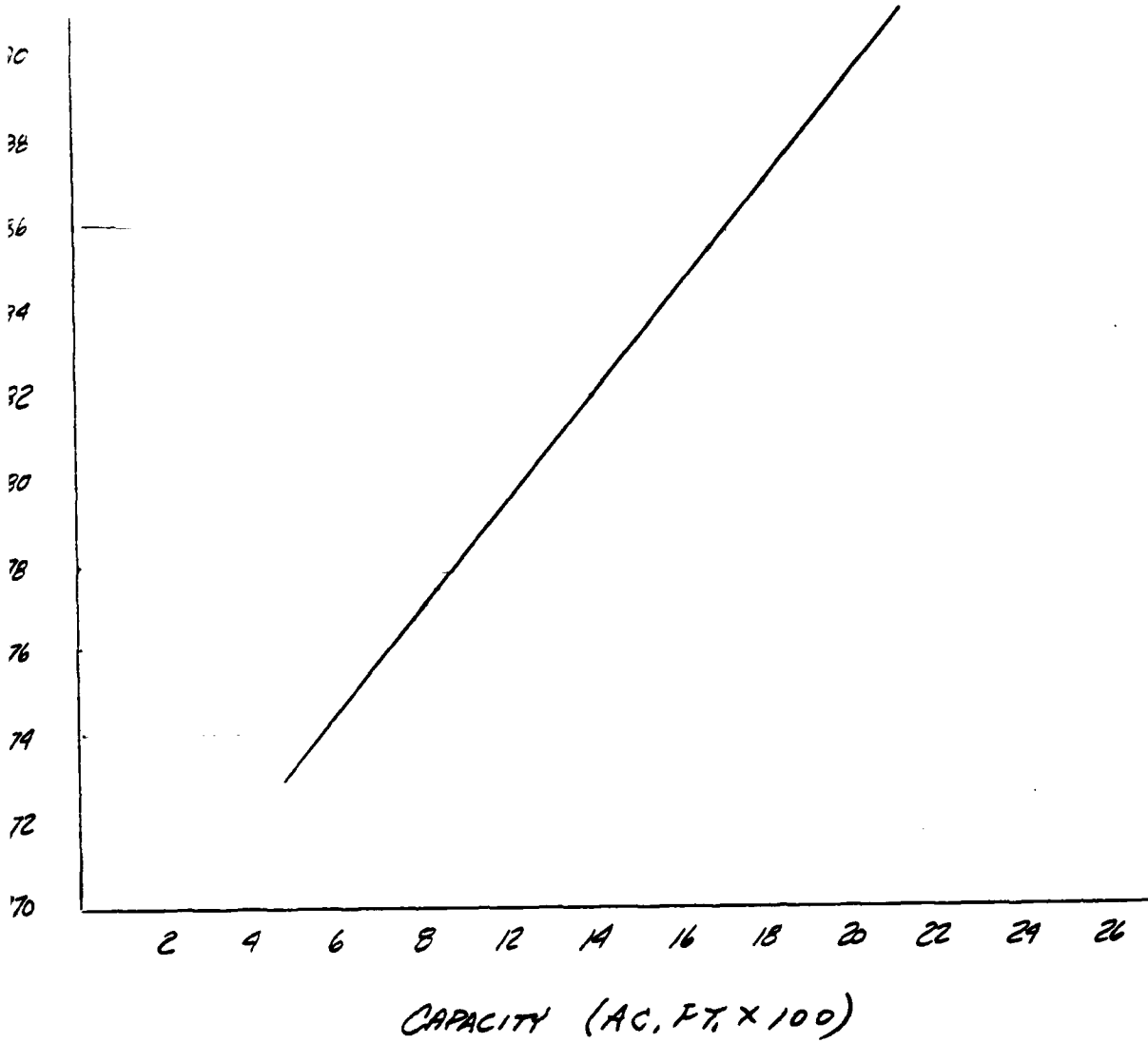

APPENDIX E

END

FILMED

7-85

DTIC