

MICROCOPY RESOLUTION TEST CHART
NATIONAL BUREAU OF STANDARDS-1963-A

3



National Defence / Défense nationale



TEST EVALUATION OF THE HONEYWELL GG1111 SINGLE-DEGREE-OF-FREEDOM (SDF) STRAPDOWN GYROSCOPE

by

M.F. Vinnins and R. Apps

DTIC FILE COPY AD-A 154 768

DTIC
ELECTE
JUN 10 1985

S
R

D

B

DEFENCE RESEARCH ESTABLISHMENT OTTAWA
TECHNICAL NOTE 85-2

Canada

October 1984
Ottawa

DISTRIBUTION STATEMENT A
Approved for public release
Distribution Unlimited

MAY 05 1985

85 5 13 112



National Défense
Defence nationale

TEST EVALUATION OF THE HONEYWELL GG1111 SINGLE-DEGREE-OF-FREEDOM (SDF) STRAPDOWN GYROSCOPE

by

M.F. Vinnins and R. Apps
*Electromagnetics Section
Electronics Division*

DTIC
ELECTE
JUN 10 1985
S B D

DEFENCE RESEARCH ESTABLISHMENT OTTAWA
TECHNICAL NOTE 85-2

PCN
32G01

October 1984
Ottawa

DISTRIBUTION STATEMENT A

Approved for public release
Distribution Unlimited

Abstract

Test results from the evaluation of a Honeywell GG1111 single-degree-of-freedom strapdown gyroscope are presented. Tests include both static and constant-rate tests in servo and in analog-torque-to-balance modes. Results of multi-position drift tests, drift stability, cool-down sensitivity, temperature sensitivity, torque generator linearity, scale factor stability and torque generator sensitivity to input axis rate changes are presented, described and discussed.

Résumé

On présente les résultats de l'évaluation d'un gyroscope sans plate-forme stabilisée Honeywell GG1111 à un seul degré de liberté. On a effectué des essais statiques et des essais à vitesse constante en mode d'asservissement et par utilisation d'un signal analogique pour équilibrer le couple. On présente, décrit et étudie les résultats d'essais de dérive à positions multiples, la stabilité de dérive, la sensibilité au refroidissement, la sensibilité thermique, la linéarité du générateur de couple, la stabilité du facteur d'échelle et la sensibilité du générateur de couple aux variations de la vitesse d'accès en entrée.

PREVIOUS PAGE IS BLANK

DTIC COPY NUMBER

| | |
|--------------------|-------------------------------------|
| Accession For | |
| NTIS GRA&I | <input checked="" type="checkbox"/> |
| DTIC TAB | <input type="checkbox"/> |
| Unannounced | <input type="checkbox"/> |
| Justification | |
| By | |
| Distribution/ | |
| Availability Codes | |
| Avail and/or | |
| Dist | Special |
| A-1 | |

TABLE OF CONTENTS

| | <u>Page</u> |
|---|-------------|
| Abstract/Résumé..... | iii |
| 1.0 Introduction..... | 1 |
| 1.1 The Honeywell GG1111 Gyroscope..... | 1 |
| 2.0 Static and Constant-Rate Tests..... | 4 |
| 2.1 The Test Facility..... | 4 |
| 2.2 Test Results..... | 4 |
| 2.2.1 5-Position Test..... | 6 |
| 2.2.2 Drift Stability Test..... | 7 |
| 2.2.3 Cool-Down Sensitivity of BD and ADIA..... | 13 |
| 2.2.4 Temperature Sensitivity of the Drift Coefficients | 13 |
| 2.2.5 Torque Generator Sensitivity (Scale Factor) Linearity..... | 13 |
| 2.2.6 Scale Factor Stability..... | 18 |
| 2.2.7 Torque Generator Sensitivity to IA Rate Change..... | 25 |
| 3.0 Conclusions and Recommendations | 25 |
| 4.0 References | 26 |

Test Evaluation of the Honeywell GG1111
SDF Strapdown Gyroscope

1.0 INTRODUCTION

This report presents the results of an extensive series of tests evaluating the Honeywell GG1111, Single-Degree-of-Freedom (SDF) strapdown gyroscope. Tests were performed in both static and constant rate environments (see DREO TN 83-18) to measure drift coefficients, drift stabilities, torquer scale factor, scale factor linearity as well as thermal sensitivities. Scale factor linearity and stability under constant rate inputs were evaluated using a Honeywell analog rebalance loop.

Although gyroscopes of such quality are not usually employed as vehicle inertial navigators, it is felt that with proper characterization of the error terms of the instruments, many of the errors can be modelled and compensated for in navigation software resulting in substantial improvements in system performance. This is particularly applicable in integrated systems where aiding sensors are available and low cost is highly desirable.

This report will describe the Honeywell GG1111 gyro, the test facilities and the test results. All testing was performed within the DREO Inertial Navigation Laboratory, a description of which can be found in DREO Report #895, The DREO Inertial Navigation Laboratory: Development and Test Capabilities [A].

1.1. THE HONEYWELL GG1111 GYROSCOPE

The Honeywell GG1111 is a SDF, rate-integrating, floated gyro. Figure 1-1 shows the basic elements of a SDF gyro. The gyro depicted is of the rate-integrating type; that is, the deflection of the gyro element relative to the case is a measure of the integral of the angular velocity of the gyro about its sensitive (input) axis (i.e. change of angular attitude of the instrument). The 'damper' in the figure provides the primary restraining torque on the instrument.

The performance specifications of the Honeywell model GG1111 gyro are given in Table 1-1. Note that this is a floated-type low grade inertial instrument with very high bias and acceleration-sensitive drifts and relatively poor stability. Other instruments in this class include the Lear Siegler model 1903 and Northrop model GI-G6. Typical applications for this grade of gyroscope include short range missile guidance, attitude and heading reference systems and other forms of low-cost inertial guidance.

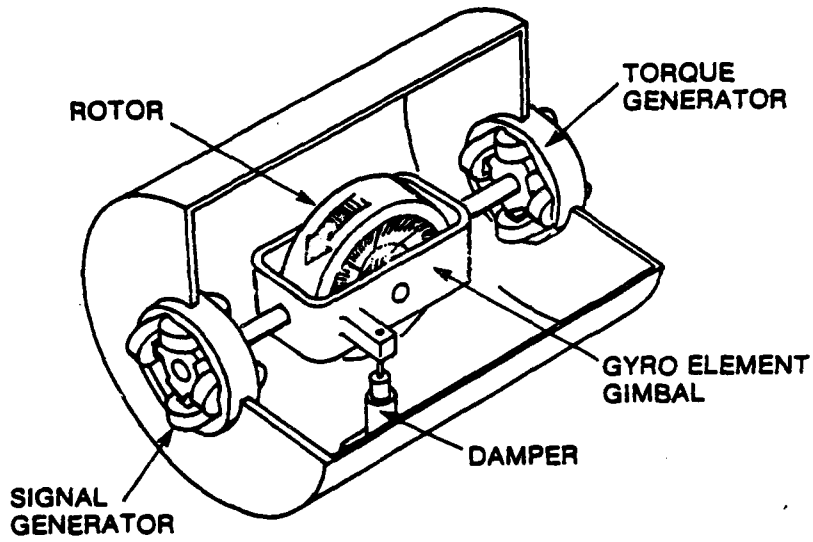

Figure 1-1 Essential Elements of a Rate Integrating Single-degree-of-freedom (SDF) Gyroscope

| <u>Parameter</u> | <u>GG1111 (AJ03)</u> |
|---------------------------------|--|
| Size | |
| Length | 2.38 in. |
| Diameter | 1.295 in. |
| Gimbal Freedom | $\pm 0.35-1.50$ deg. |
| Operating Temp | 185°F |
| Spin Motor Power | |
| Start | 5.0 W. max. |
| Run | 4.0 W. max. |
| Torque Generator | |
| Sensitivity(STG) | 3960 deg/h/ma. |
| Max. Torquing Rate (continuous) | ± 220 deg/sec |
| Linearity | 0.1% of full scale (to 100 deg/sec) |
| Pickoff Sensitivity | 68 mV/deg. |
| Heaters | None |
| G-Insensitive Drift | |
| Magnitude | ± 50.0 deg/hr |
| Stability | ± 8.0 deg/hr (6 mos) |
| G-Sensitive Drift | |
| Magnitude | 12.0 deg/hr/g (vector sum) |
| Stability | 17.0 deg/hr/g (vector sum) |
| G ² Sensitive Drift | |
| Magnitude | 0.2 deg/hr/g ² (20-2000Hz) |
| Run-Up Time | 15 sec. max (185°F) |

Table 1-1 Honeywell GG 1111 - Performance Characteristics

2.0 STATIC AND CONSTANT-RATE TESTS

The major error terms investigated during these tests include both G-sensitive and G-insensitive terms; bias drift (BD) and acceleration-sensitive drift about each instrument axis (ADIA, ADSRA and ADOA, where IA = input axis, SRA = spin reference axis and OA = output axis). In addition, torque generator sensitivity (scale factor) and temperature effects are also evaluated.

For all error terms, not only is the magnitude of interest but also stability, repeatability, sensitivity to temperature or rate changes and dynamic effects such as linearity and transients.

The gyro was tested in two modes; inertial reference servo mode where the motion table servo loop is used to drive the table to oppose earth rate and gyroscopic drift and torque -to-balance mode whereby the gyro float is nulled by the application of current to the gyro torquer coil by means of an electronic sensing and feedback circuit.

2.1 THE TEST FACILITY

The DREO Inertial Navigation Laboratory was designed to be a highly versatile and flexible test facility for inertial components and systems. The core of the facility is a Contravs-Goerz 2-axis motion simulator (model 57CD) capable of azimuth rates from 0-1000 deg/sec. System support equipment includes variable frequency wheel and signal generator supplies controlled by a highly stable frequency source. Data acquisition is accomplished automatically through an LSI-11 microprocessor connected to all test equipment by way of an IEEE-488 bus. Data reduction is performed on other site computers providing analysis and plotting capabilities. A photograph of the laboratory is shown in Figure 2-1.

2.2 TEST RESULTS

The tests performed on the Honeywell GG1111 gyro include:

1. 5-position drift test (drift coefficients BD, ADIA, ADSRA, ADOA)
2. Drift stability test - IA vertical up
- IA horizontal north



Figure 2-1 DREO Gyroscope Test Station

3. Cool-down sensitivity of BD and ADIA
4. Temperature sensitivity of BD, AD/A, ADSRA, ADOA
5. Torque Generator Sensitivity (Linearity)
6. Scale Factor Stability
7. Sensitivity to an IA Rate Change

All tests were performed in both inertial reference servo mode and analog-torque-to-balance (ATBL) mode.

2.2.1 5-Position Test

The drift coefficients BD, ADIA, ADSRA and ADOA were extracted from the results of a 5-position test employing the following gyro orientations:

- a) IA vertical up, OA west
- b) IA horizontal north, SRA vertical
- c) IA horizontal north, SRA vertical down
- d) IA horizontal north, OA vertical up
- e) IA horizontal north, OA vertical down

The sign convention adopted (DREO TN 83-18) [B] assumes that instrument drift causes clockwise (CW) rotation of the inertial table top and this is defined as positive drift.

For IA vertical up, we define

$$\text{DRIFT} = \text{BD} + \text{ADIA}$$

and for IA horizontal north,

| | |
|-----------|---|
| SRA up: | $\text{DRIFT} + \text{BD} + \text{ADSRA}$ |
| SRA down: | $\text{DRIFT} = \text{BD} - \text{ADSRA}$ |
| OA up: | $\text{DRIFT} = \text{BD} + \text{ADOA}$ |
| OA down: | $\text{DRIFT} = \text{BD} - \text{ADOA}$ |

Table 2-1 lists the results of the 5-position test in servo mode and Table 2-2 in analog-torque-to-balance loop mode. Results agree favourably between the two modes although ADIA is different. This is most probably due to the cool-down sensitivity of ADIA in this type of instrument and is illustrated in section 2.2.3. Note that all drift coefficients are well within the denoted Honeywell specifications but that it is not, in fact, the magnitude of the coefficients that is so important but rather repeatability and long-term stability.

2.2.2. Drift Stability Test

Drift stability tests were performed with the instrument stabilized at its operating temperature. In servo mode, the table rate is sampled over a 24 hour period for both IA vertical up and IA horizontal north orientations. In ATBL mode, the current to the rebalance loop is sampled over a 24 hour period while the motion table is locked into each of the previously mentioned axes orientations. It should be noted that the results of the ATBL mode tests actually include the stability of the rebalance loop electronics itself from the viewpoint of temperature stability etc.

Figure 2-2 shows the results of a stability test in servo mode, IA vertical up. The average drift over the 24-hour period is + 16.50 deg/hr with a drift stability of 2.53 deg/hr.

Figure 2-3 is the same test performed with IA horizontal north. Note the 'cosine' outline to the drift; this is a result of instrument misalignment on the table top resulting in a slight coning motion of the input axis as the table top rotates in this orientation. The indicated drift stability is worse than in Figure 2-2, approximately 6.0 deg/hr except in the 110 to 170 degree table positions; the wild fluctuations in instrument drift seem unreasonable and are, most likely, the effect of external influences such as a problem in the motion table.

Results are similar when using the rebalance loop. Figure 2-4 show the drift stability over 18 hours. From the figure:

$$I_{DC} \text{ max} = 4.926 \mu \text{ Amp}$$

$$I_{DC} \text{ min} = 4.248 \mu \text{ Amp}$$

$$\Delta I_{DC} = 0.678 \times 10^{-6} \text{ Amp.}$$

$$S_{TG} = 4024.7 \text{ deg/hr/ma (nominal)}$$

$$\text{Drift Stability} = 2.73 \text{ deg/hr}$$

Honeywell GG1111 S/N P-8

| | Honeywell Specification | 11 Aug 82 | 18 Aug. 82 | 20 Aug. 82 | 24 Aug. 82 |
|------------|----------------------------|-----------|------------|------------|------------|
|) | | | | | |
| ADSRA) | <u>+50</u> deg/hr | -1.3 | -3.2 | -7.0 | -4.6 |
| DIA | Vector | -2.2 | -6.5 | -2.7 | -2.9 |
| DSRA | 12deg/hr/g | -5.3 | -5.0 | -7.0 | -4.7 |
| DOA | | - | +0.8 | +0.7 | +1.8 |
| D | | | | | |
| ADOA) | <u>+50</u> deg/hr | - | -4.3 | -3.7 | -5.1 |
| ector Sum* | 12 deg/hr/g | +5.7 | +8.2 | +7.5 | +5.6 |

$$*Vector\ Sum = \left[(ADIA)^2 + (ADSRA)^2 \right]^{1/2}$$

Averages: BD(ADSRA) = -4.0 deg/hr

ADIA = -3.6 deg/hr/g

ADSRA = -5.5 deg/hr/g

ADOA = +1.1 deg/hr/g

BD(ADOA) = -4.3 deg/hr

Table 2-1. Drift Coefficients, 5-Position Servo Tests

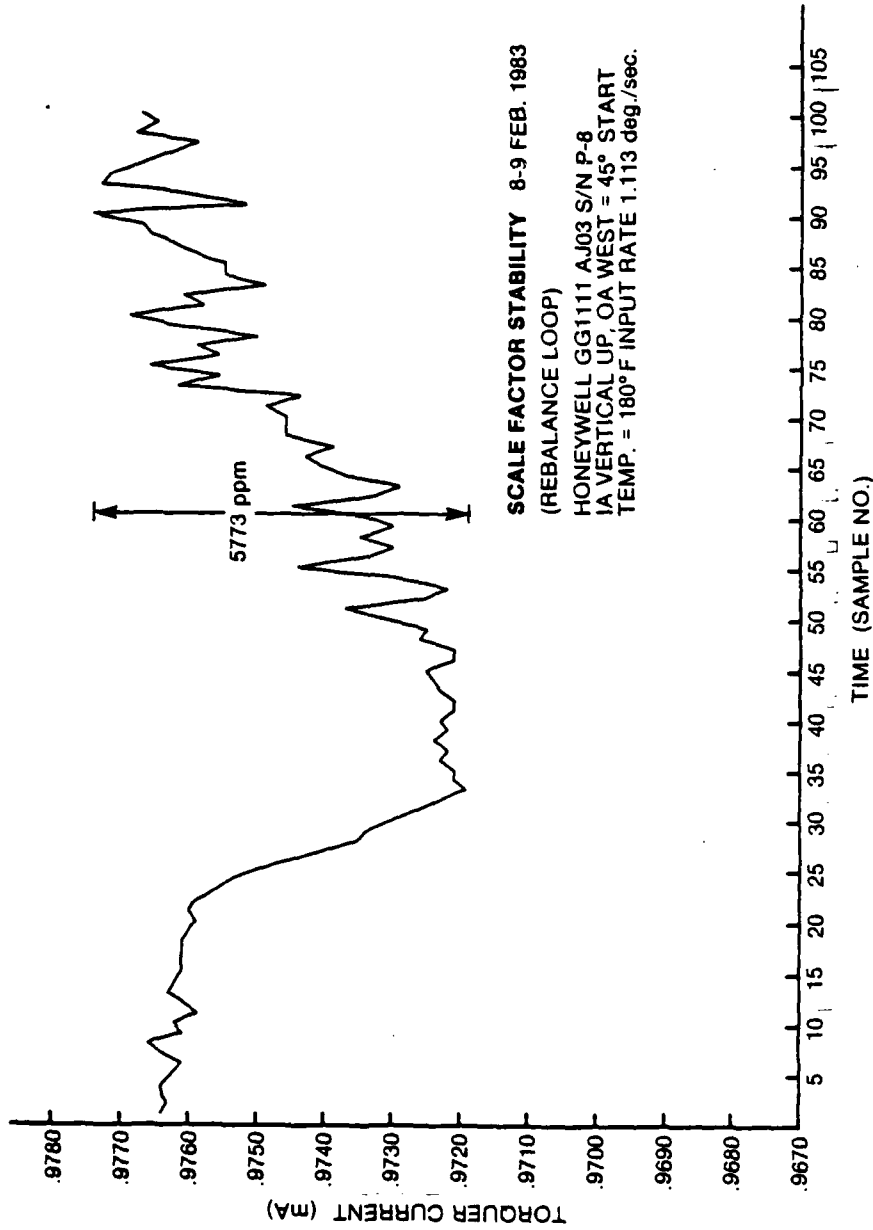

SCALE FACTOR STABILITY 8-9 FEB. 1983
 (REBALANCE LOOP)
 HONEYWELL GG1111 A-J03 S/N P-8
 IA VERTICAL UP, OA WEST = 45° START
 TEMP. = 180°F INPUT RATE 1.113 deg./sec.

Figure 2-12 Torquer Scale Factor Stability

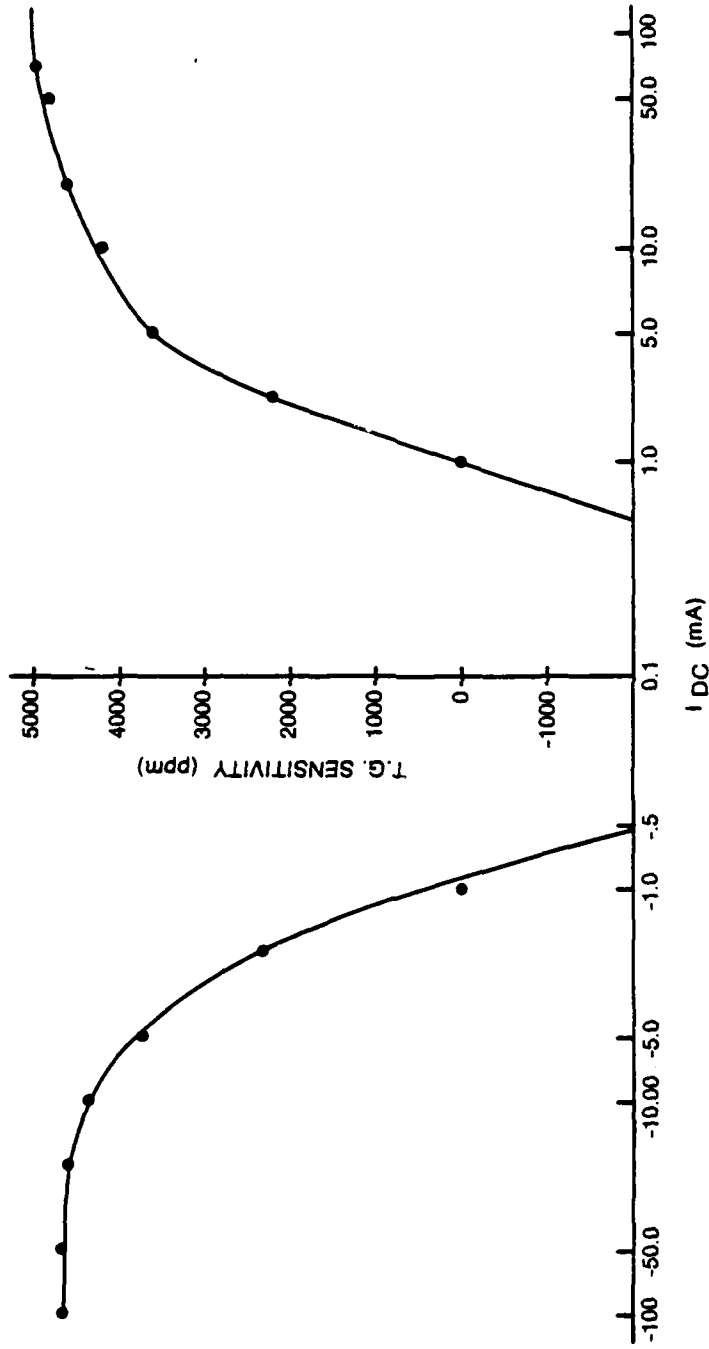

Figure 2-11 Torque Generator Linearity

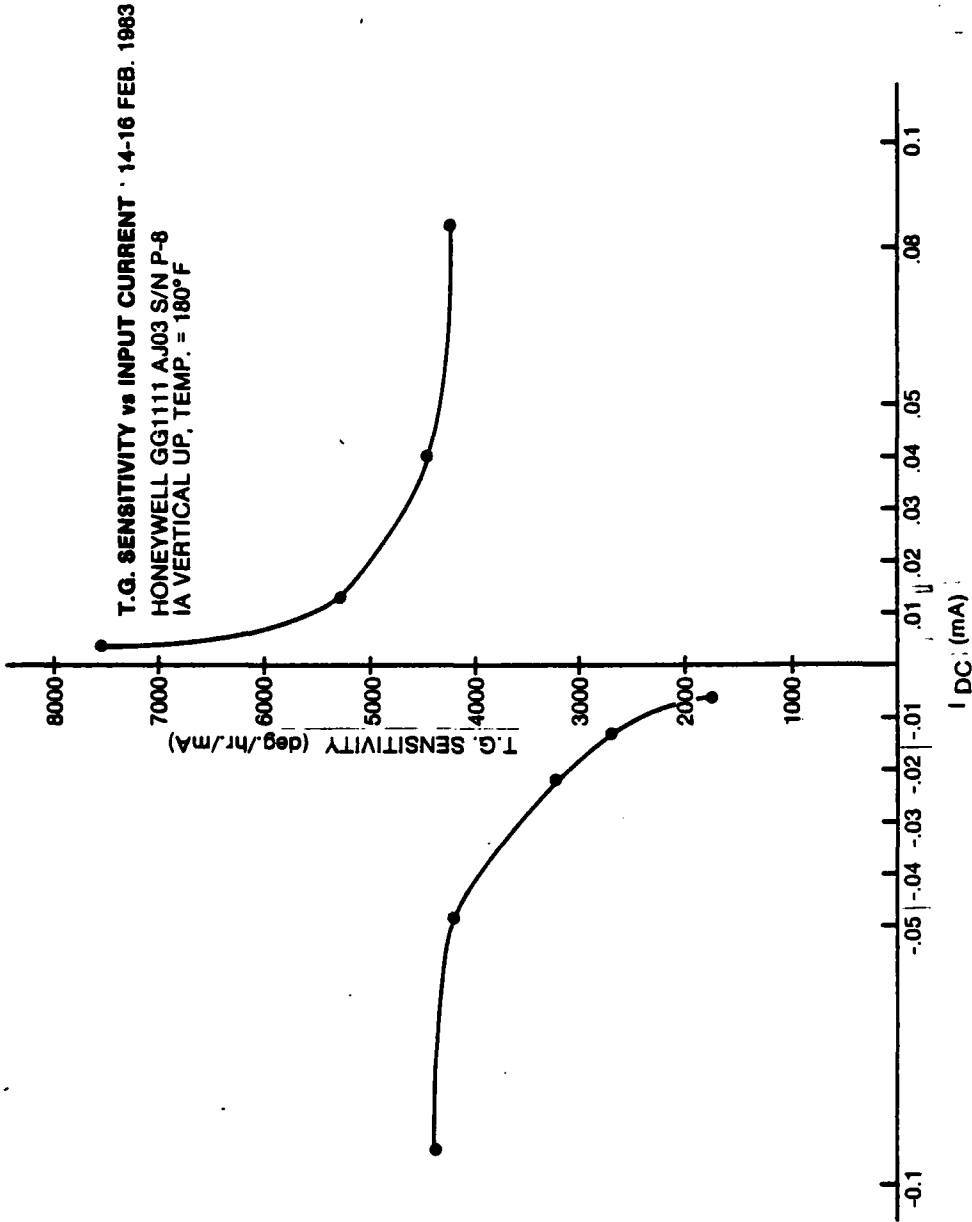

Figure 2-10 Torque Generator Sensitivity

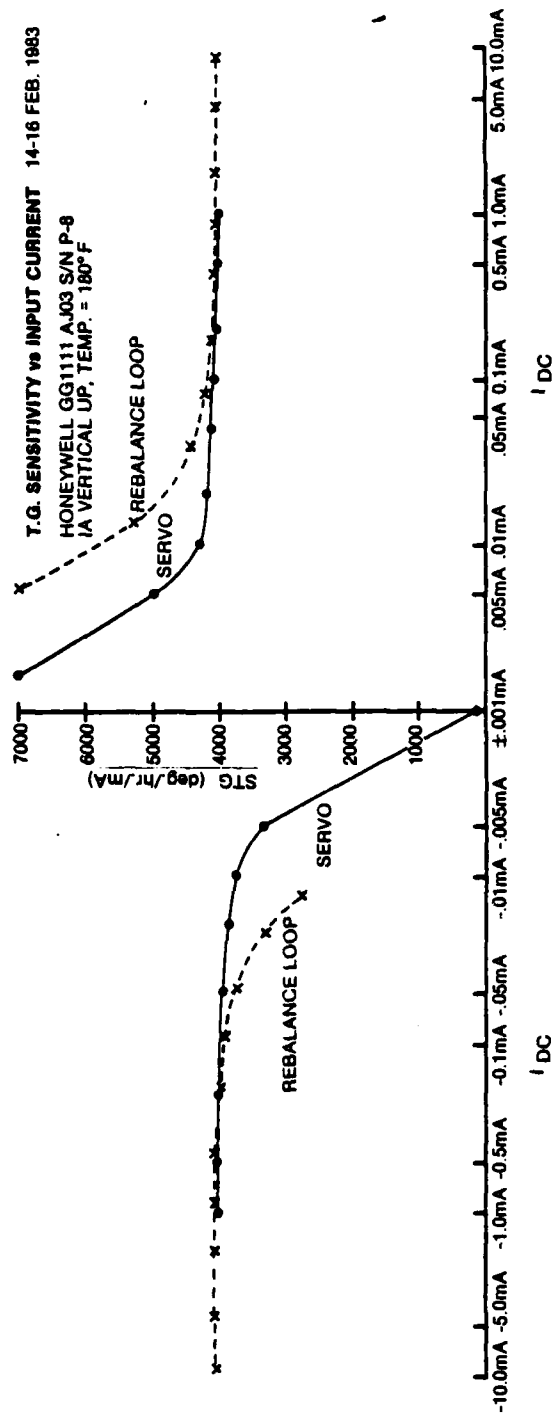

Figure 2-9 Scale Factor Linearity

$$S_{TG} = (\text{Total Rate} - \text{Drift})/I_{DC}$$

Nominal scale factor for this instrument is 4024 deg/hr/ma.

S_{TG} (Scale Factor) linearity is determined in the following way. In servo mode, a precise DC current is fed into the torquer coil and the resulting table motion is sampled. In ATBL mode, the table is driven at precise rates and the restoring current fed to the torquer by the rebalance loop is sampled.

Figure 2-9 shows the torque generator linearity for both modes vs input current. The rebalance loop is incapable of delivering very precise low currents evidenced by the fact that at very low table rates, the restoring current was completely erratic being lost in the 'noise'. In servo mode, the DC current source is capable of delivering very stable, precise low current levels and, therefore, measurements could be taken at lower table rates. An expanded view of torque generator sensitivity at low current levels is shown in Figure 2-10 for servo mode.

It is evident that the torque generator is non-linear, particularly at the lower angular rates (5 deg/hr) but performs much better at higher rates. A plot of T.G. linearity in ppm is shown in Figure 2-11 illustrating this. It should be noted that an inertial grade instrument would be expected to be linear to better than 100 ppm; the GG1111 performed no better than 4500 ppm.

2.2.6 Scale Factor Stability

Scale factor stability is determined from 10 hour tests during which the gyro is driven at a constant angular rate and the restoring current provided to the torque generator is sampled. Plots of scale factor stability at 1.113 deg/sec and 10.0 deg/sec are shown in Figures 2-12 and 2-13. As expected, scale factor stability is better at higher angular rates; 1673 ppm at 10.0 deg/sec versus 5773ppm at 1.113 deg/sec. over a ten hour period. Tests performed at higher rates (up to 140 deg/sec) showed similar results.

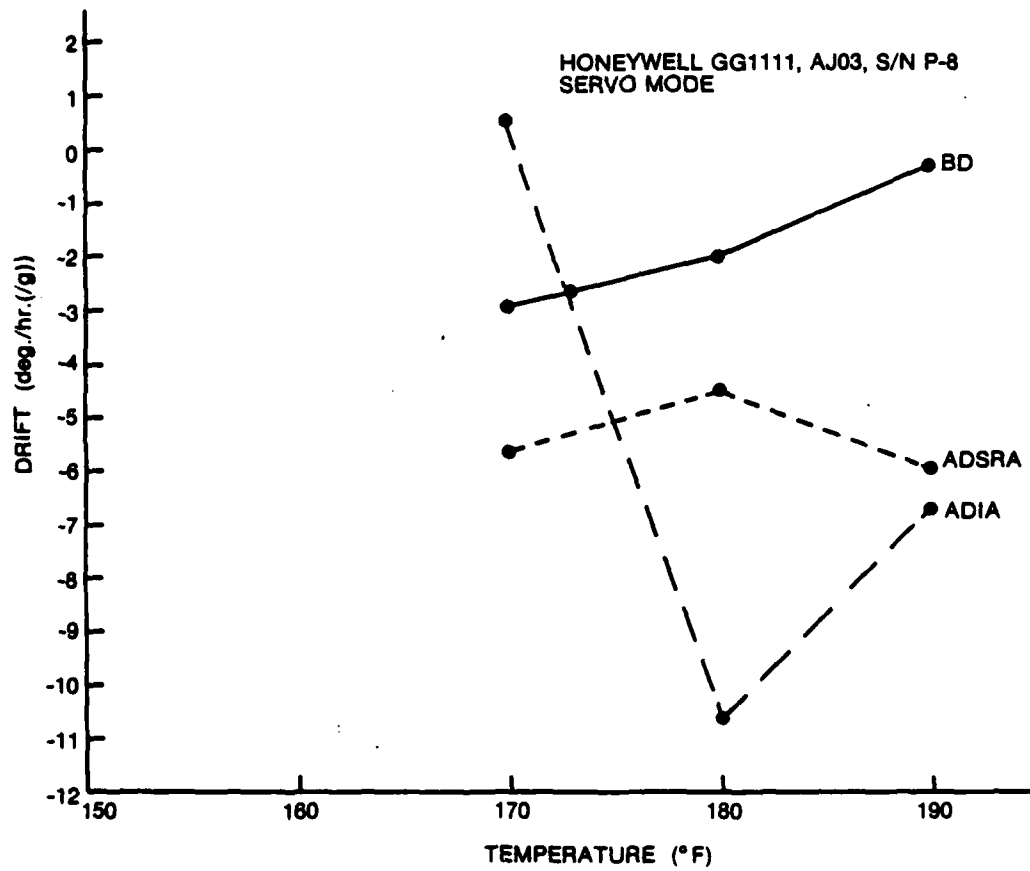

Figure 2-8 Temperature Sensitivity of BD, ADIA, ADSRA

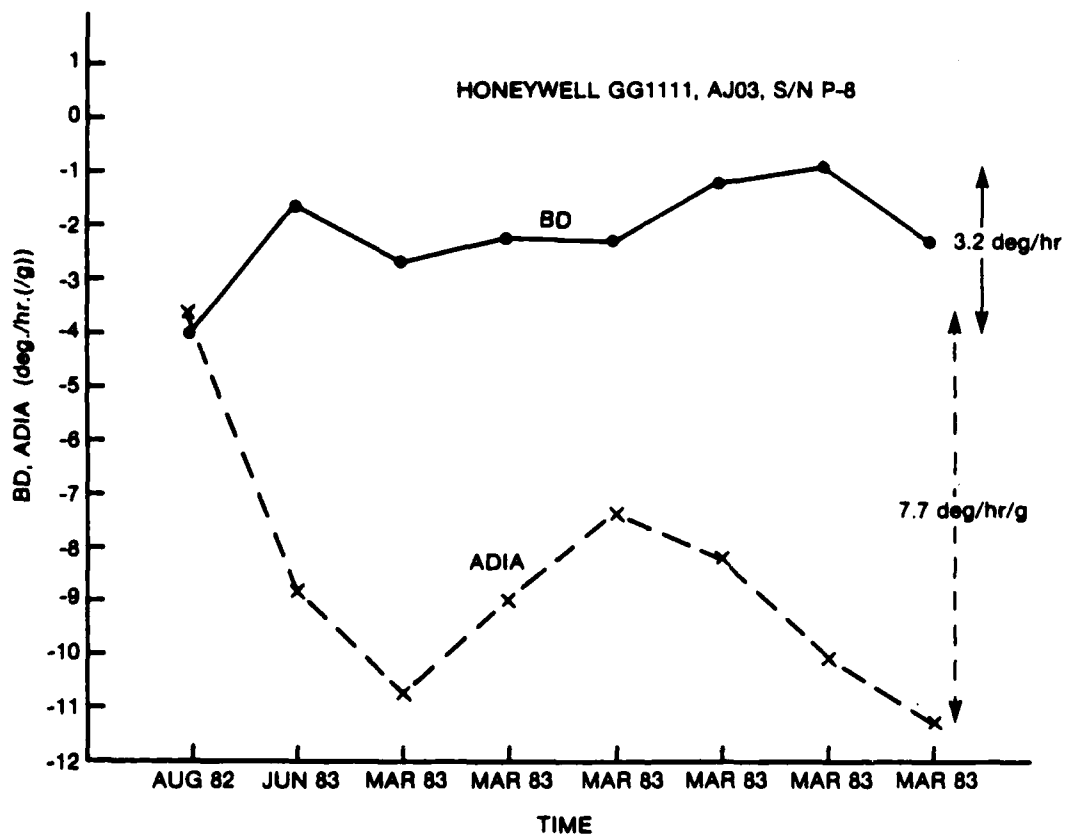

Figure 2-7 Cool Down Sensitivity of BD, ADIA

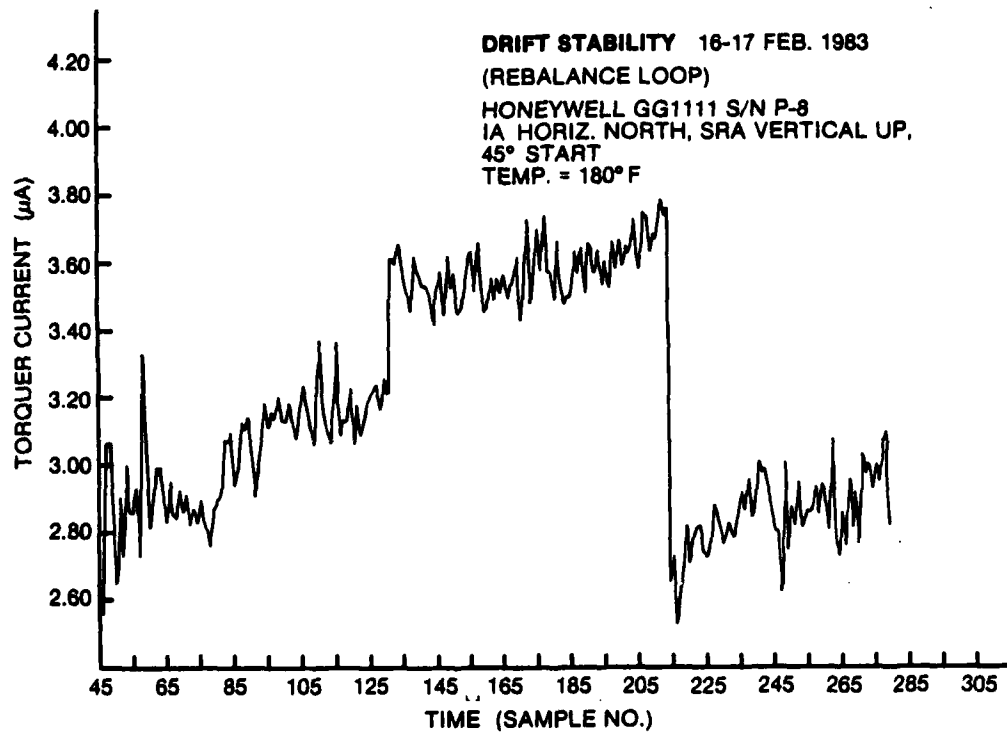

Figure 2-6 Drift Stability

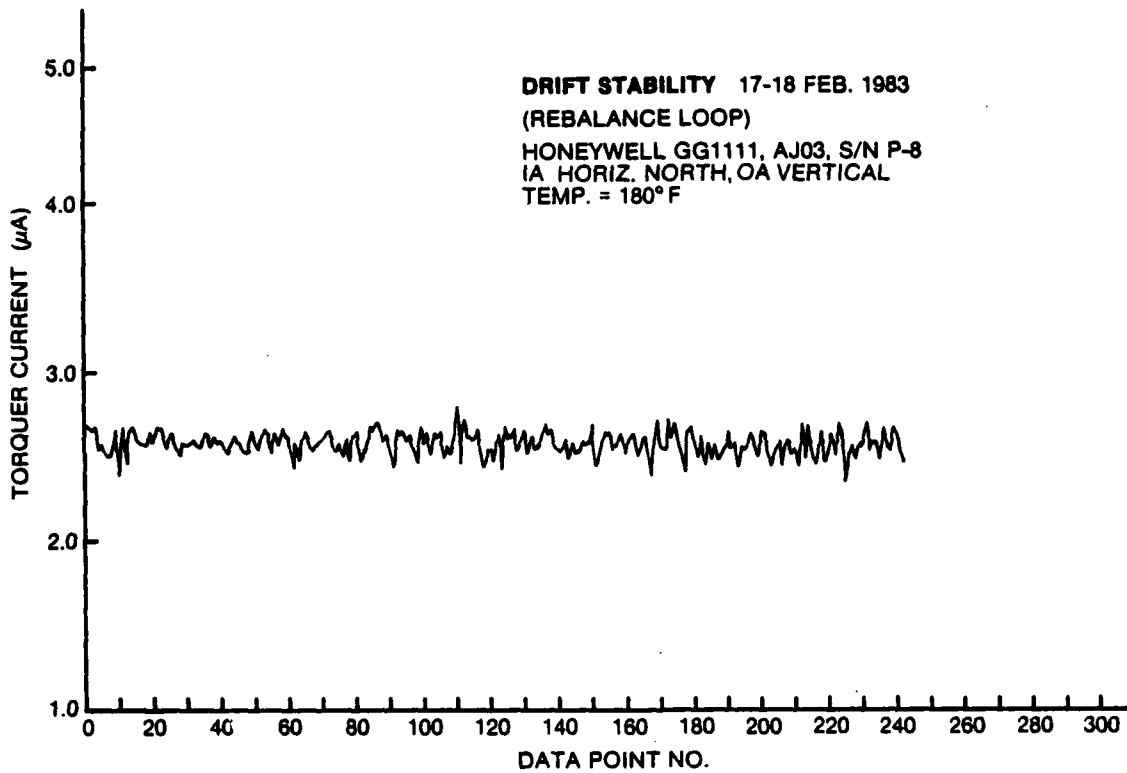

Figure 2-5 Drift Stability

Similar results are shown in Figures 2-5 and 2-6 where the drift stabilities are 1.747 deg/hr and 4.93 deg/hr respectively although in Figure 2-6, a sudden shift is evident. The reason for this sudden change is not clear although the drift seems to reassume a similar pattern after the disturbance indicating that the effect is likely external to the instrument.

In summary, a drift stability of less than 6.0 deg/hr would seem to be indicated for this instrument. This also is within Honeywell specifications.

2.2.3 Cool-Down Sensitivity of BD and ADIA

Both BD and ADIA are, in general, sensitive to temperature changes and cool-down. The 5-position test was repeated several times between which the gyro was turned off, cooled to room temperature and then reheated. A plot of cool-down sensitivity is shown in Figure 2-7. The bias drift changes by as much as 3.2 deg/hr and ADIA by 7.7 deg/hr/g between cool-downs. This unfortunately implies very poor instrument repeatability.

2.2.4 Temperature Sensitivity of the Drift Coefficients

Not only are several of the drift coefficients sensitive to cool-down but also to changes in operating temperature. The operating temperature as supplied by the manufacturer is usually the optimum temperature for the instrument with respect to minimizing drift coefficients.

The Honeywell gyro was run at three different temperatures, 170^oR, 180^oF and 190^oF without cool down between changes. Figure 2-8 shows plots of BD, ADIA and ADSRA with respect to operating temperature. As shown in 2.2.3 BD and ADIA are most sensitive to temperature; ADIA changes by 11.2 deg/hr/g and BD by 2.5 deg/hr. In general ADOA is unaffected by cool down or temperature change.

2.2.5 Torque Generator Sensitivity (Scale Factor) Linearity

From the random drift tests, one can calculate the Torque Generator Sensitivity (STG), sometimes referred to as DC scale factor. In the IA vertical up orientation, Random Drift = BD+ADIA. The average random drift from the tests performed was +16.626 deg/hr and, by definition,

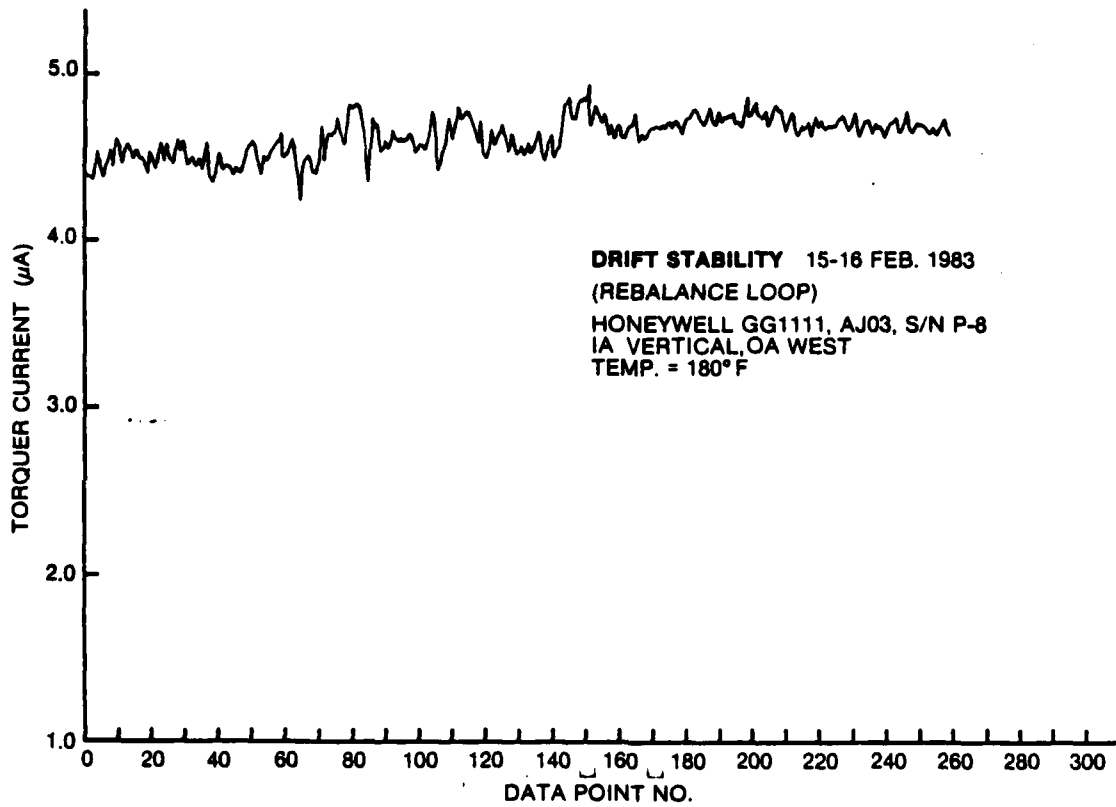

Figure 2-4 Drift Stability

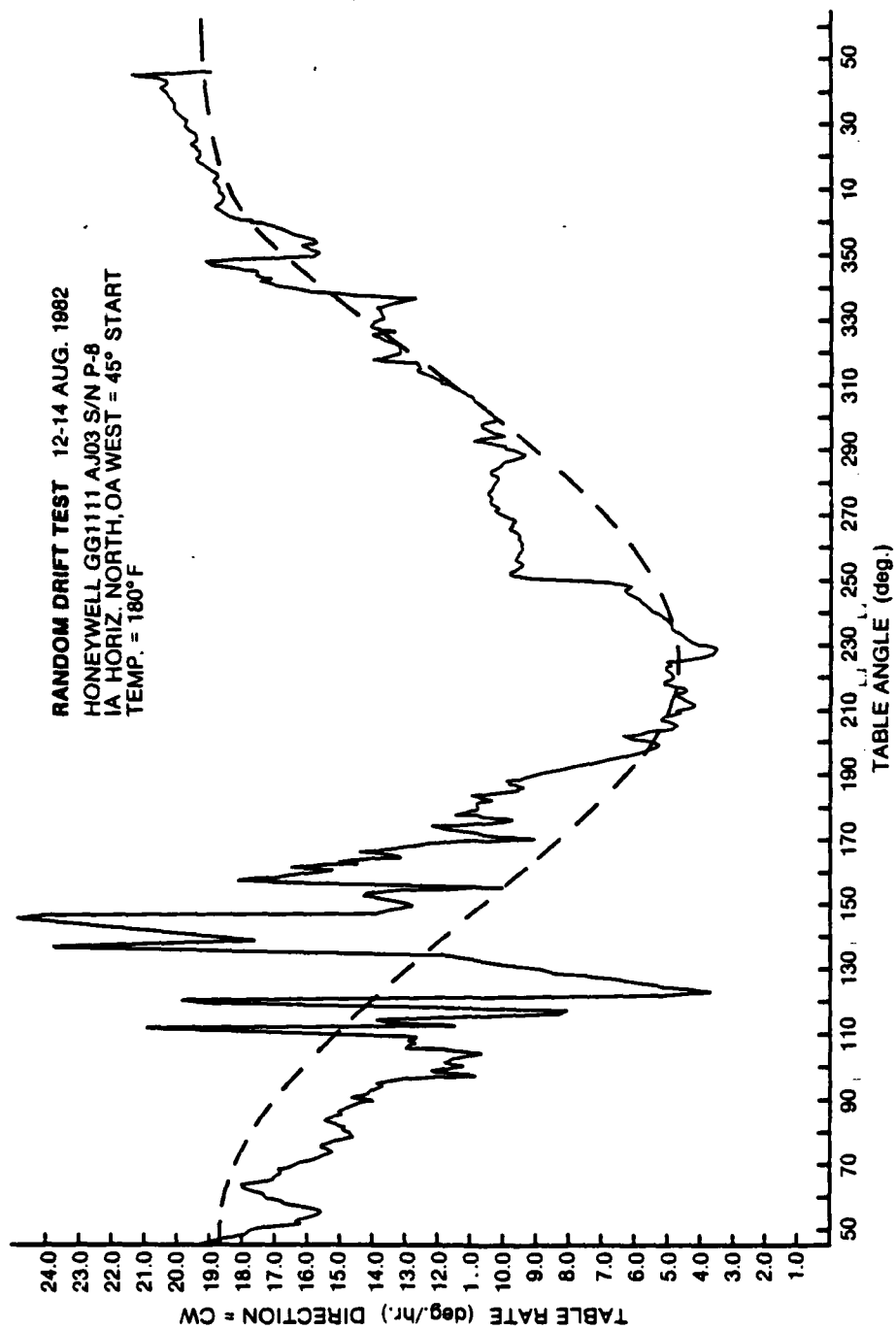

Figure 2-3 Drift Stability

RANDOM DRIFT TEST 11-12 AUG. 1982
HONEYWELL GG1111 AJ03 S/N P-8
IA VERTICAL UP, OA WEST = 45° START
TEMP. = 180° F

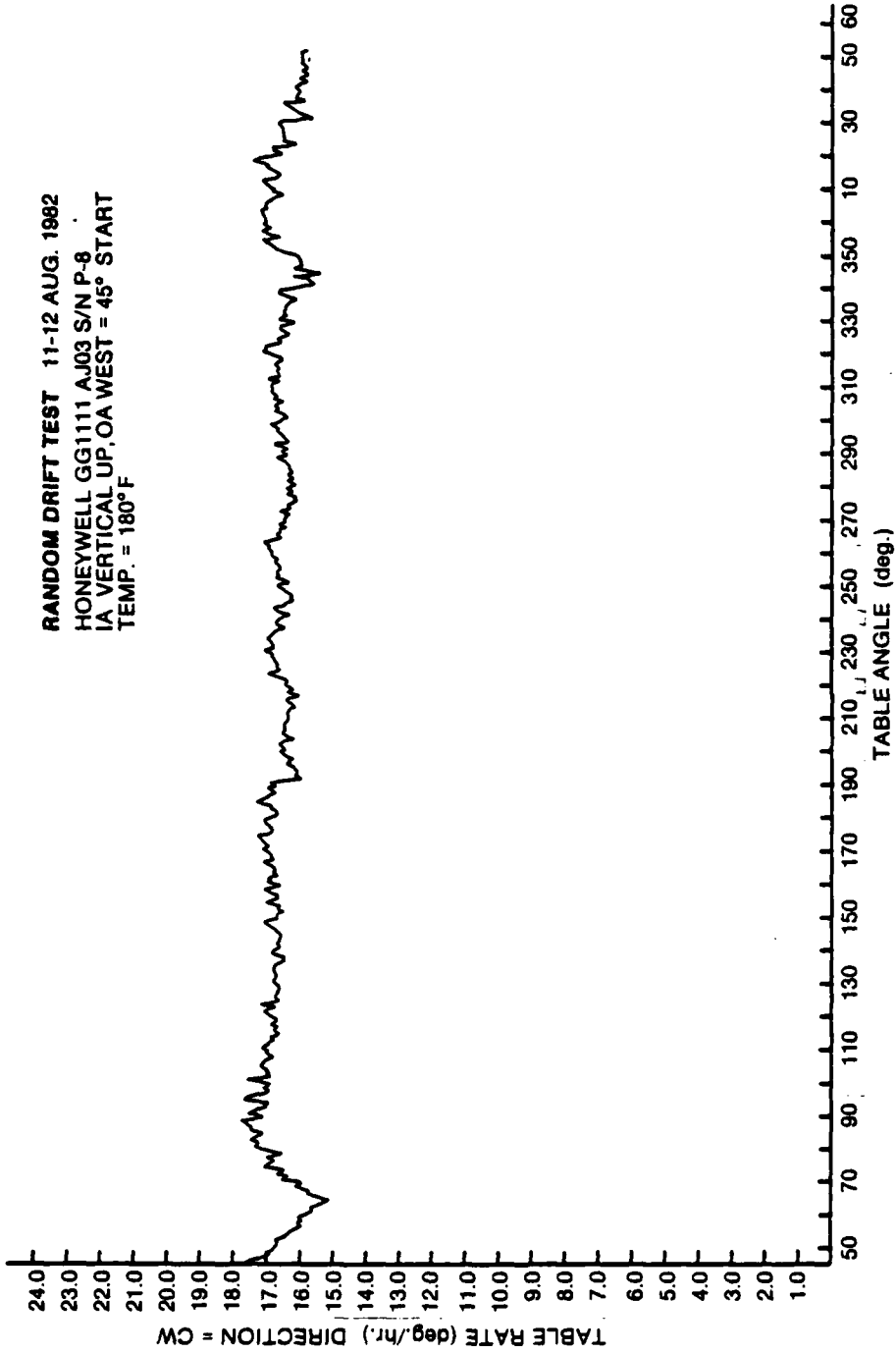

Figure 2-2 Drift Stability

Honeywell GG1111 S/N P-8

| Honeywell | | 7 FEB. 83 | 8 Feb 83 | 9 Feb. 83 | 10 Feb 83 | 11 Feb. 83 |
|---------------|-------------------|-----------|----------|-----------|-----------|------------|
| Specification | | | | | | |
| BD (ADSRA) | <u>+50 deg/hr</u> | -0.4 | -2.7 | -3.7 | -2.6 | -0.7 |
| ADIA | Vector | -12.3 | -8.0 | -5.4 | -7.8 | -9.0 |
| ADSRA | 12deg/hr/g | -3.1 | -4.5 | -3.8 | -5.9 | -4.2 |
| ADOA | | 0 | -0.1 | 0 | -0.1 | -0.6 |
| BD (ADOA) | <u>+50 deg/hr</u> | -1.7 | -1.8 | -2.4 | -1.4 | -1.2 |
| Vector Sum* | 12 deg/hr/g | -12.7 | -9.2 | 6.6 | 9.8 | 9.9 |

$$*\text{Vector Sum} = \left[(\text{ADIA})^2 + (\text{ADSRA})^2 \right]^{1/2}$$

Averages: BD(ADSRA) = -1.6 deg/hr

ADIA = -8.8 deg/hr/g

ADSRA = -4.5 deg/hr/g

ADOA = +0.2 deg/hr/g

BD(ADOA) = -1.7 deg/hr

Table 2-2. Drift Coefficients, 5-Position Rebalance Loop Tests

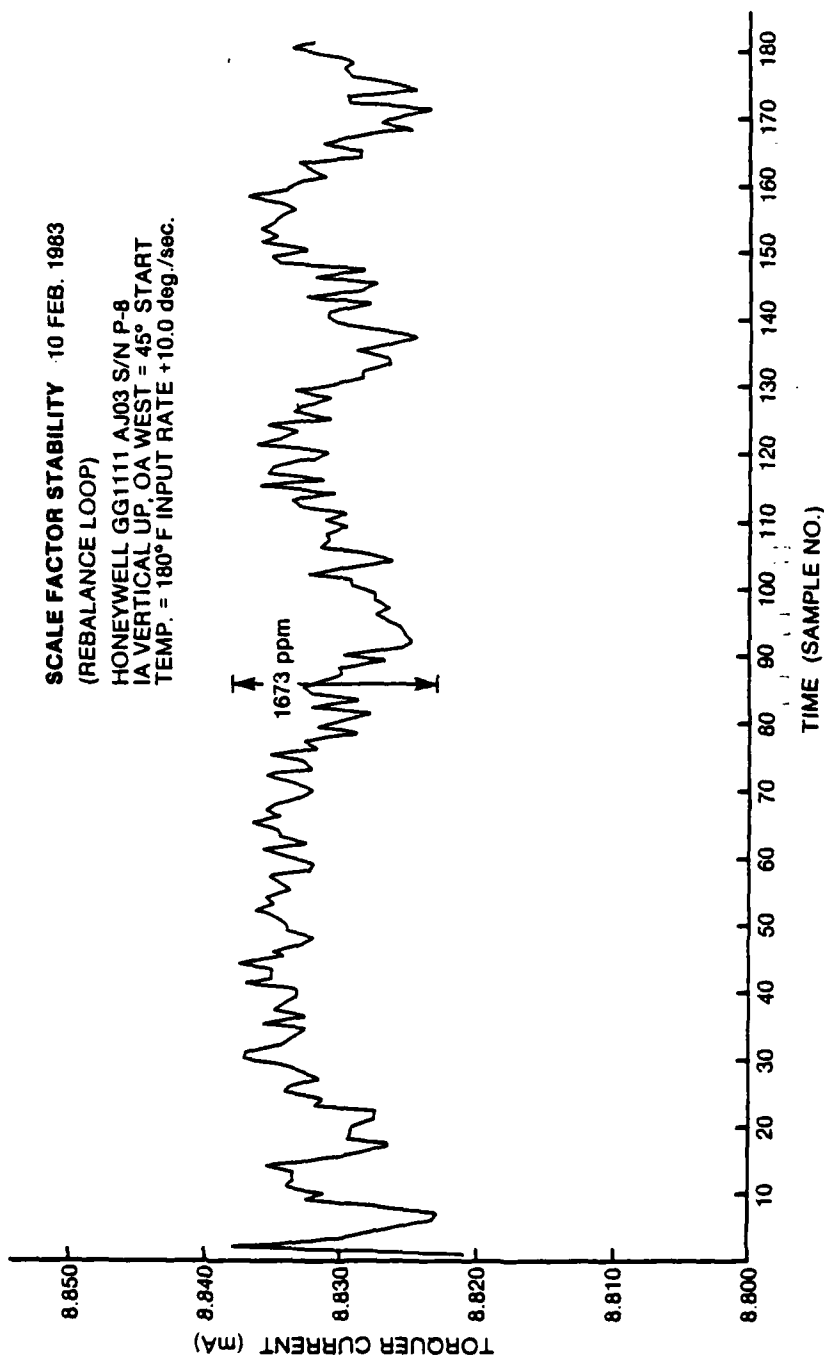

Figure 2-13 Torquer Scale Factor Stability

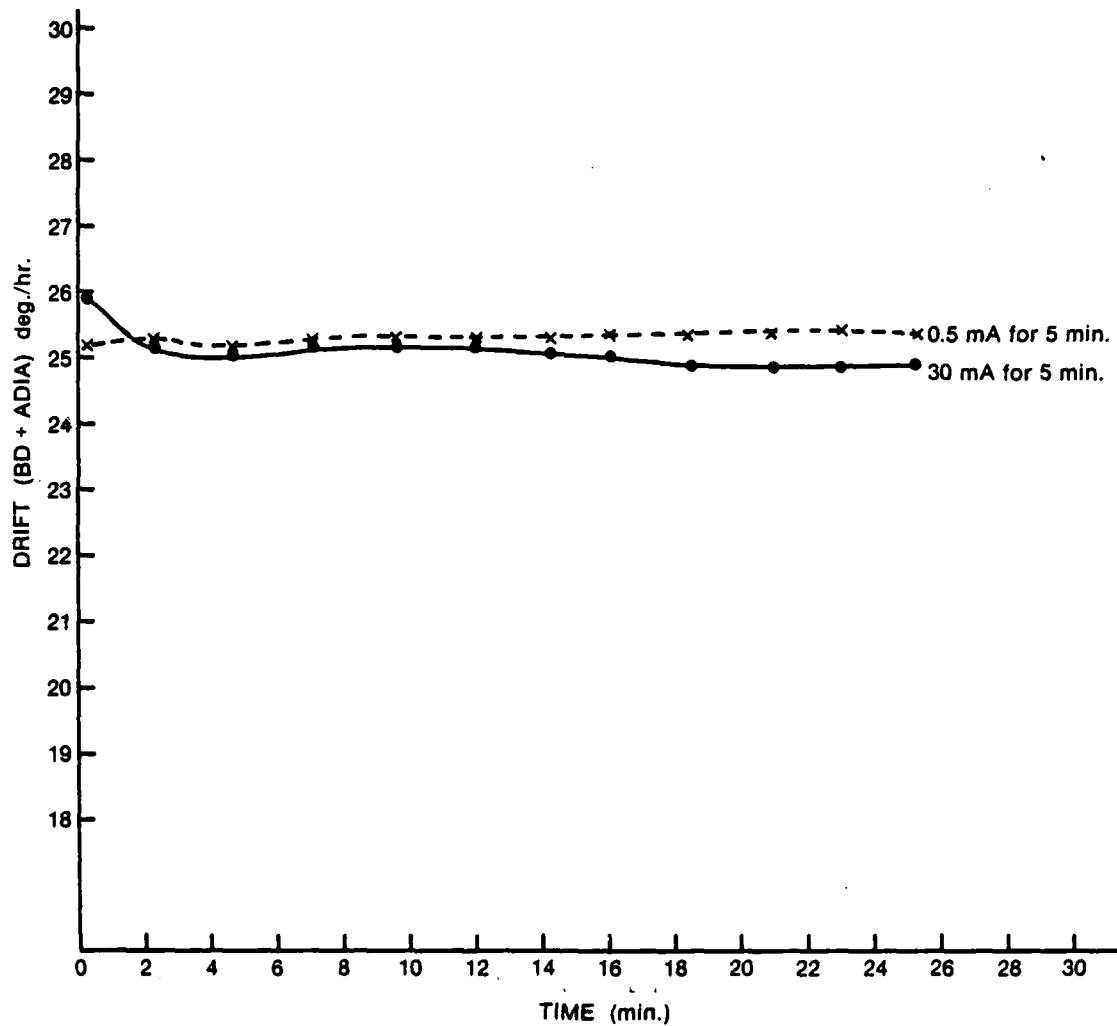

Figure 2-14 Effect of an IA Rate Change

2.2.7. Torque Generator Sensitivity to IA Rate Change

In a strapdown instrument, sudden changes in dynamics (angular rates) cause large changes in restoring current to the torquer coil. These changes cannot be instantaneous and it is likely that some transient effect due to torquer coil heating or hysteresis will occur. To investigate the effect of sudden rate changes on instrument drift a series of tests was performed. With the gyro in the IA vertical up orientation, the table was driven at a constant rate (30 deg/sec) for 5 minutes and then stopped. The instrument drift was then measured for 30 minutes to detect any transient effects. Figure 2-4 shows the long term (30 minute) effect of rate change and it is evident that there is no significant effect. In fact, the transient disappeared in all cases within one minute of each change and very often within a few seconds. Unfortunately, the data recording system was not capable of sampling quickly enough to obtain the transient data. It should be noted that even seemingly short transients in instrument drift will result in substantial system errors, particularly under severe dynamics.

3.0 CONCLUSIONS AND RECOMMENDATIONS

The Honeywell GG1111 gyroscope performed within the stated specifications in a static environment:

- a. Drift stability was determined to be 6.0 deg/hr.
- b. Bias and g-sensitive drift coefficient amplitudes were less than 4.5 deg/hr and 12 deg/hr/g respectively.
- c. Both BD and ADIA showed high sensitivity to cool down and operating temperature changes.

The torque generator was found to be non linear, particularly at low angular rates (<5 deg/sec). At higher rates (5 deg/sec to 140 deg/sec), performance improved. Scale Factor stability was also poor at low rates but, again, improved at higher rates; typically to less than 2000 ppm. The torque generators showed no long term shift in sensitivity due to IA rate changes but did demonstrate a short transient, typically less than 10 seconds.

In conclusion, the instrument qualifies as a low grade gyroscope useable in such strapdown applications as short range missile guidance. Due to its high sensitivity to temperature and cool-down, it is unlikely that this gyro could be used in AHRS or navigation applications.

4.0 REFERENCES

- A) 'The DREO Inertial Navigation Laboratory: Development and Test Capabilities', M. Vinnins, DREO Report # 895, June 1984.

- B) 'Procedures for Static and Constant-Rate Tests on a Single-Degree-of-Freedom (SDF) Strapdown Gyroscope' R. Apps and M. Vinnins, DREO TN 83-18, October 1983.

A154 768

UNCLASSIFIED

Security Classification

| DOCUMENT CONTROL DATA - R & D | | |
|---|--|--|
| (Security classification of title, body of abstract and indexing annotation must be entered when the overall document is classified) | | |
| 1. ORIGINATING ACTIVITY Defence Research Establishment Ottawa | | 2a. DOCUMENT SECURITY CLASSIFICATION UNCLASSIFIED |
| | | 2b. GROUP |
| 3. DOCUMENT TITLE Test Evaluation of the Honeywell GG1111 Single-Degree-of-Freedom (SDF) Strapdown Gyroscope | | |
| 4. DESCRIPTIVE NOTES (Type of report and inclusive dates) Tech Note | | |
| 5. AUTHOR(S) (Last name, first name, middle initial) Vinnins, Michael F. and Apps, R.G. | | |
| 6. DOCUMENT DATE Oct 1984 | 7a. TOTAL NO. OF PAGES 26 | 7b. NO. OF REFS 2 |
| 8a. PROJECT OR GRANT NO. 32G01 | 9a. ORIGINATOR'S DOCUMENT NUMBER(S) | |
| 8b. CONTRACT NO. | 9b. OTHER DOCUMENT NO.(S) (Any other numbers that may be assigned this document) | |
| 10. DISTRIBUTION STATEMENT Unlimited Distribution | | |
| 11. SUPPLEMENTARY NOTES | 12. SPONSORING ACTIVITY | |
| 13. ABSTRACT Test results from the evaluation of a Honeywell GG1111 Single-Degree-of-Freedom Strapdown Gyroscope are presented. Tests include both static and constant-rate tests in servo and in analog-torque-to-balance modes. Results of multi-position drift tests, drift stability, cool-down sensitivity, temperature sensitivity, torque generator linearity, scale factor stability and torque generator sensitivity to IA rate changes are presented, described and discussed. | | |

UNCLASSIFIED

Security Classification

KEY WORDS

✓ GYROSCOPE
STRAPDOWN
HONEYWELL GG1111

INSTRUCTIONS

1. **ORIGINATING ACTIVITY** Enter the name and address of the organization issuing the document.
- 2a. **DOCUMENT SECURITY CLASSIFICATION** Enter the overall security classification of the document including special warning terms whenever applicable.
- 2b. **GROUP** Enter security reclassification group number. The three groups are defined in Appendix 'M' of the DRB Security Regulations.
3. **DOCUMENT TITLE** Enter the complete document title in all capital letters. Titles in all cases should be unclassified. If a sufficiently descriptive title cannot be selected without classification, show title classification with the usual one-capital-letter abbreviation in parentheses immediately following the title.
4. **DESCRIPTIVE NOTES** Enter the category of document, e.g. technical report, technical note or technical letter. If appropriate, enter the type of document, e.g. interim, progress, summary, annual or final. Give the inclusive dates when a specific reporting period is covered.
5. **AUTHOR(S)** Enter the name(s) of author(s) as shown on or in the document. Enter last name, first name, middle initial. If military, show rank. The name of the principal author is an absolute minimum requirement.
6. **DOCUMENT DATE** Enter the date (month, year) of Establishment approval for publication of the document.
- 7a. **TOTAL NUMBER OF PAGES** The total page count should follow normal pagination procedures, i.e., enter the number of pages containing information.
- 7b. **NUMBER OF REFERENCES** Enter the total number of references cited in the document.
- 8a. **PROJECT OR GRANT NUMBER** If appropriate, enter the applicable research and development project or grant number under which the document was written.
- 8b. **CONTRACT NUMBER** If appropriate, enter the applicable number under which the document was written.
- 9a. **ORIGINATOR'S DOCUMENT NUMBER(S)** Enter the official document number by which the document will be identified and controlled by the originating activity. This number must be unique to this document.
- 9b. **OTHER DOCUMENT NUMBER(S)** If the document has been assigned any other document numbers (either by the originator or by the sponsor), also enter this number(s).
10. **DISTRIBUTION STATEMENT** Enter any limitations on further dissemination of the document, other than those imposed by security classification, using standard statements such as:
 - (1) "Qualified requesters may obtain copies of this document from their defence documentation center."
 - (2) "Announcement and dissemination of this document is not authorized without prior approval from originating activity."
11. **SUPPLEMENTARY NOTES** Use for additional explanatory notes.
12. **SPONSORING ACTIVITY** Enter the name of the departmental project office or laboratory sponsoring the research and development. Include address.
13. **ABSTRACT** Enter an abstract giving a brief and factual summary of the document, even though it may also appear elsewhere in the body of the document itself. It is highly desirable that the abstract of classified documents be unclassified. Each paragraph of the abstract shall end with an indication of the security classification of the information in the paragraph (unless the document itself is unclassified) represented as (TS), (S), (C), (R), or (U).
The length of the abstract should be limited to 20 single-spaced standard typewritten lines, 7 1/2 inches long.
14. **KEY WORDS** Key words are technically meaningful terms or short phrases that characterize a document and could be helpful in cataloging the document. Key words should be selected so that no security classification is required. Identifiers, such as equipment model designation, trade name, military project code name, geographic location, may be used as key words but will be followed by an indication of technical context.

END

FILMED

7-85

DTIC