

MICROCOPY RESOLUTION TEST CHART
NATIONAL BUREAU OF STANDARDS-1963-A

AD-A155 382

CHARLES RIVER BASIN
MILFORD, MASSACHUSETTS

CEDAR SWAMP POND DAM
MA 00628

PHASE I INSPECTION REPORT
NATIONAL DAM INSPECTION PROGRAM

Copy available to DTIC does not
guarantee fully legible reproduction

DTIC
ELECTE

JUN 2 0 1985



S * G

DTIC FILE COPY

DEPARTMENT OF THE ARMY
NEW ENGLAND DIVISION, CORPS OF ENGINEERS
WALTHAM, MASS. 02154

DISTRIBUTION STATEMENT A
Approved for public release
Distribution Unlimited

JULY 1978

85 5 28 240

UNCLASSIFIED

SECURITY CLASSIFICATION OF THIS PAGE (When Data Entered)

REPORT DOCUMENTATION PAGE		READ INSTRUCTIONS BEFORE COMPLETING FORM
1. REPORT NUMBER MA 00628	2. GOVT ACCESSION NO. AD-A155382	3. RECIPIENT'S CATALOG NUMBER
4. TITLE (and Subtitle) Cedar Swamp Pond Dam NATIONAL PROGRAM FOR INSPECTION OF NON-FEDERAL DAMS		5. TYPE OF REPORT & PERIOD COVERED INSPECTION REPORT
7. AUTHOR(s) U.S. ARMY CORPS OF ENGINEERS NEW ENGLAND DIVISION		6. PERFORMING ORG. REPORT NUMBER
9. PERFORMING ORGANIZATION NAME AND ADDRESS		8. CONTRACT OR GRANT NUMBER(s)
11. CONTROLLING OFFICE NAME AND ADDRESS DEPT. OF THE ARMY, CORPS OF ENGINEERS NEW ENGLAND DIVISION, NEDED 424 TRAPELO ROAD, WALTHAM, MA. 02254		10. PROGRAM ELEMENT, PROJECT, TASK AREA & WORK UNIT NUMBERS
14. MONITORING AGENCY NAME & ADDRESS (if different from Controlling Office)		12. REPORT DATE July 1978
		13. NUMBER OF PAGES 56
		15. SECURITY CLASS. (of this report) UNCLASSIFIED
		15a. DECLASSIFICATION/DOWNGRADING SCHEDULE
16. DISTRIBUTION STATEMENT (of this Report) APPROVAL FOR PUBLIC RELEASE: DISTRIBUTION UNLIMITED		
17. DISTRIBUTION STATEMENT (of the abstract entered in Block 20, if different from Report)		
18. SUPPLEMENTARY NOTES Cover program reads: Phase I Inspection Report, National Dam Inspection Program; however, the official title of the program is: National Program for Inspection of Non-Federal Dams; use cover date for date of report.		
19. KEY WORDS (Continue on reverse side if necessary and identify by block number) DAMS, INSPECTION, DAM SAFETY, Charles River Basin Milford, Massachusetts Charles River		
20. ABSTRACT (Continue on reverse side if necessary and identify by block number) The dam consists of an 11 ft. high concrete spillway combined with an 8 ft. high earthfill embankment. The concrete ogee-spillway is about 100 ft. long. It is in good condition. However, there are a number of problems which should be corrected. It has been reported that the Cedar swamp Pond Dam has been overtopped.		

DISCLAIMER NOTICE

THIS DOCUMENT IS BEST QUALITY PRACTICABLE. THE COPY FURNISHED TO DTIC CONTAINED A SIGNIFICANT NUMBER OF PAGES WHICH DO NOT REPRODUCE LEGIBLY.

Accession For	
NTIS GRA&I	<input checked="" type="checkbox"/> <input type="checkbox"/> <input type="checkbox"/>
DTIC TAB	
Unannounced Justification	
By _____	
Distribution/ _____	
Availability Codes	
Dist	Avail and/or Special
A/1123	WV

CEDAR SWAMP POND DAM

MA 00628

CHARLES RIVER BASIN
MILFORD, MASSACHUSETTS

PHASE I INSPECTION REPORT
NATIONAL DAM INSPECTION PROGRAM

NATIONAL DAM INSPECTION
PROGRAM

PHASE I INSPECTION REPORT

BRIEF ASSESSMENT

Identification No.: MA00628

Name of Dam: Cedar Swamp Pond

Town: Milford

County and State: Worcester County, Massachusetts

Stream: Charles River

Date of Inspection: June 14, 1978

Cedar Swamp Pond Dam, which was constructed in 1939, consists of an 11 foot high concrete spillway combined with an 8 foot high earthfill embankment. The concrete ogee-type spillway is about 100 feet long. The outlet control is comprised of two 4-foot square steel slide gates located in the left abutment of the spillway section. Three sheets of Contract Drawings, dated 1938, for this dam have been reproduced and included in Appendix B.

Based on the visual inspection, drawings available for the dam, and past operational performance, it is judged that Cedar Swamp Pond Dam is in good condition. However, there are a number of problems which should be corrected. These include: local erosion of the dam slopes, large trees on the dam embankment, spalling of the spillway concrete, and an accumulation of weeds, soil, and debris in the downstream channel. It was also noted that the access plates to the flashboards on the spillway deck are welded shut. These conditions should be repaired within a period of 2-4 years after receipt of the Phase I Inspection Report.

Hydraulic analyses indicate that the existing spillway can discharge a flow of 2,840 cubic feet per second (cfs) at Elevation (El) 272.5 which is the minimum top of the dam. The spillway is adequate to

discharge the inflow test flood of 3,513 cfs (one-half of the probable maximum flood) without significantly overtopping the main dam. It has been reported that Cedar Swamp Pond Dam has been overtopped. It appears that this is actually submergence caused by the backwater effect of the culvert under Main Street.

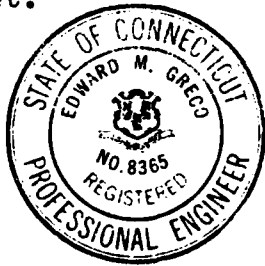

A handwritten signature in cursive script, appearing to read "Edward M. Greco".

Edward M. Greco, P.E.
Project Manager
Metcalf & Eddy, Inc.

Connecticut Registration
No. 08365

Approved by:

A handwritten signature in cursive script, appearing to read "Stephen L. Bishop".

Stephen L. Bishop, P.E.
Vice President
Metcalf & Eddy, Inc.

Massachusetts Registration No. 19703



This Phase I Inspection Report on the Cedar Swamp Pond Dam has been reviewed by the undersigned Review Board members. In our opinion, the reported findings, conclusions, and recommendations are consistent with the Recommended Guidelines for Safety Inspection of Dams, and with good engineering judgment and practice, and is hereby submitted for approval.

Charles G. Tiersch

CHARLES G. TIERSCH, Chairman
Chief, Foundation and Materials Branch
Engineering Division

Fred J. Ravens, Jr.

FRED J. RAVENS, Jr., Member
Chief, Design Branch
Engineering Division

Saul Cooper

SAUL COOPER, Member
Chief, Water Control Branch
Engineering Division

APPROVAL RECOMMENDED:

Joe B. Fryar

JOE B. FRYAR
Chief, Engineering Division

SEP 14 1978

PREFACE

This report is prepared under guidance contained in Recommended Guidelines for Safety Inspection of Dams, for a Phase I Investigation. Copies of these guidelines may be obtained from the Office of Chief of Engineers, Washington, D.C. 20314. The purpose of a Phase I Investigation is to identify expeditiously those dams which may pose hazards to human life or property. The assessment of the general condition of the dam is based upon available data and visual inspections. Detailed investigation, and analyses involving topographic mapping, subsurface investigations, testing, and detailed computational evaluations are beyond the scope of a Phase I investigation; however, the investigation is intended to identify any need for such studies.

In reviewing this report, it should be realized that the reported condition of the dam is based on observations of field conditions at the time of inspection along with data available to the inspection team. In cases where the reservoir was lowered or drained prior to inspection, such action, while improving the stability and safety of the dam, removes the normal load on the structure and may obscure certain conditions which might otherwise be detectable if inspected under the normal operating environment of the structure.

It is important to note that the condition of a dam depends on numerous and constantly changing internal and external conditions, and is evolutionary in nature. It would be incorrect to assume that the present condition of the dam will continue to represent the condition of the dam at some point in the future. Only through continued care and inspection can there be any chance that unsafe conditions be detected.

Phase I inspections are not intended to provide detailed hydrologic and hydraulic analyses. In accordance with the established Guidelines, the Spillway Test flood is based on the estimated "Probable Maximum Flood" for the region (greatest reasonably possible storm runoff), or fractions thereof. Because of the magnitude and rarity of such a storm event, a finding that a spillway will not pass the test flood should not be interpreted as necessarily posing a highly inadequate condition. The test flood provides a measure of relative spillway capacity and serves as an aid in determining the need for more detailed hydrologic and hydraulic studies, considering the size of the dam, its general condition and the downstream damage potential.

TABLE OF CONTENTS

	<u>Page</u>
BRIEF ASSESSMENT	
PREFACE	
OVERVIEW PHOTO	111
LOCATION MAP	iv
REPORT	
SECTION 1 - PROJECT INFORMATION	1
1.1 General	1
1.2 Description of Project	2
1.3 Pertinent Data	6
SECTION 2 - ENGINEERING DATA	10
2.1 General	10
2.2 Construction Records	10
2.3 Operation Records	10
2.4 Evaluation of Data	10
SECTION 3 - VISUAL INSPECTION	11
3.1 Findings	11
3.2 Evaluation	13
SECTION 4 - OPERATING PROCEDURES	14
4.1 Procedures	14
4.2 Maintenance of Dam	14
4.3 Maintenance of Operating Facilities	14
4.4 Description of Any Warning System in Effect	14
4.5 Evaluation	14
SECTION 5 - HYDRAULIC/HYDROLOGIC	15
5.1 Evaluation of Features	15

TABLE OF CONTENTS (Continued)

	<u>Page</u>
SECTION 6 - STRUCTURAL STABILITY	18
6.1 Evaluation of Structural Stability	18
SECTION 7 - ASSESSMENT, RECOMMENDATIONS, AND REMEDIAL MEASURES	20
7.1 Dam Assessment	20
7.2 Recommendations	21
7.3 Remedial Measures	21
 APPENDIXES	
APPENDIX A - PERIODIC INSPECTION CHECKLIST	A-1
APPENDIX B - DAM PLAN AND PAST INSPECTION REPORTS	B-1
APPENDIX C - PHOTOGRAPHS	C-1
APPENDIX D - HYDROLOGIC AND HYDRAULIC COMPUTATIONS	D-1
APPENDIX E - INFORMATION AS CONTAINED IN THE NATIONAL INVENTORY OF DAMS	E-1

OVERVIEW
CEDAR SWAMP POND DAM
MILFORD, MASSACHUSETTS



VIEW OF SPILLWAY

LOCATION AND DIRECTION OF
PHOTOGRAPHS SHOWN ON FIGURES
IN APPENDIX B

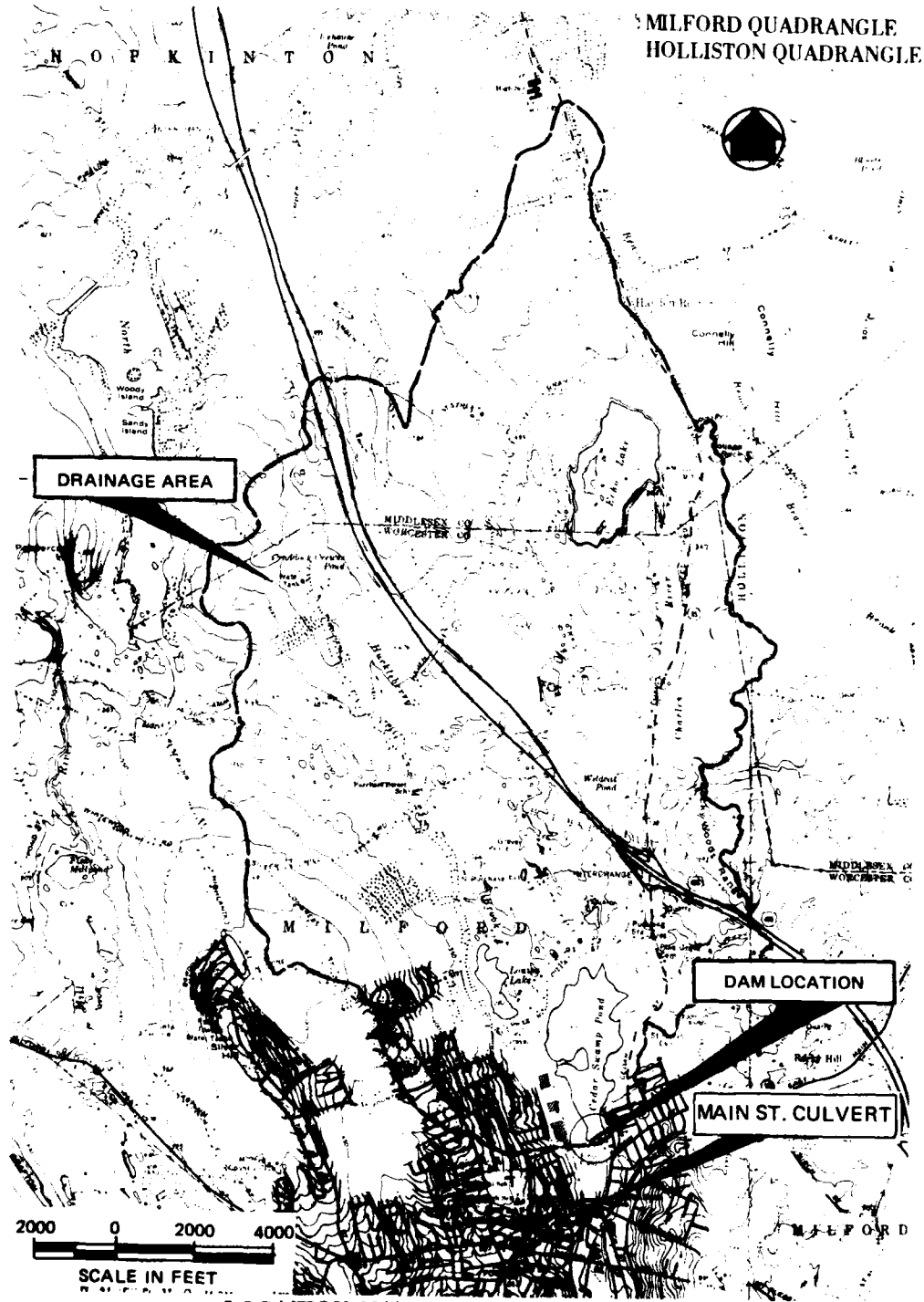

LOCATION MAP - CEDAR SWAMP POND

NATIONAL DAM INSPECTION PROGRAM

PHASE I INSPECTION REPORT

CEDAR SWAMP POND

SECTION 1

PROJECT INFORMATION

1.1 General

a. Authority. Public Law 92-367, August 8, 1972, authorized the Secretary of the Army, through the Corps of Engineers, to initiate a national program of dam inspection throughout the United States. The New England Division of the Corps of Engineers has been assigned the responsibility of supervising the inspection of dams within the New England Region. Metcalf & Eddy, Inc. has been retained by the New England Division to inspect and report on selected dams in the State of Massachusetts. Authorization and notice to proceed was issued to Metcalf & Eddy, Inc. under a letter of May 3, 1978, from Ralph T. Garver, Colonel, Corps of Engineers. Contract No. DACW 33-78-C-0306 has been assigned by the Corps of Engineers for this work.

b. Purpose

- (1) Perform technical inspection and evaluation of non-Federal dams to identify conditions which threaten the public safety and thus permit correction in a timely manner by non-Federal interests.
- (2) Encourage and assist the states to initiate quickly effective dam safety programs for non-Federal dams.
- (3) To update, verify, and complete the National Inventory of Dams.

1.2 Description of Project

- a. Location. The dam is located in the Town of Milford, Worcester County, Massachusetts, on the Charles River. See Location Map.
- b. Description of Dam and Appurtenances. Cedar Swamp Pond Dam consists of an 11-foot high concrete spillway combined with an 8-foot high earthfill embankment (see Figures B-1, B-2, and B-3 in Appendix B). The spillway is an ogee-type weir with two sluice gates at the eastern end and an overhead concrete deck supported by concrete piers and sidewalls (see overview photo). The spillway weir including piers is 100 feet long, 4.5 feet high and about 10.5 feet wide at the base. Steel sheeting is shown as a cutoff beneath the weir and continuing through the earth embankment. Wooden flashboards 10 inches high by 10 feet long by 2 inches thick* are mounted with steel pins to the spillway crest. The elevation of the spillway crest is 268.5*, and the top of the flashboards is at El 269.3.*

There are five concrete piers spaced at 20 foot intervals on the weir, and a sixth pier 5.5 feet to the east. The five piers are 5.5 feet high, the sixth is 10 feet high, and they are 6 feet wide by 1.5 feet thick.* The piers are flared at the top to meet the width of the overlying deck.

Two openings, 9.5 feet high by 4 feet wide, are located between the spillway weir and the east abutment. The flow through the sluiceway is controlled by two 4-foot square steel slide gates operated by two gate wheels which are accessible from the deck surface. The wheels are padlocked when not in operation.

A concrete service and walkway deck crosses the spillway weir. The deck is 113.5 feet long by 10.3 feet wide by 1 foot thick. The

*Indicates information derived from the Contract Drawings (Figures B-1, B-2, and B-3 in Appendix B) and not directly measured in the field.

11/11

elevation of the deck surface is 275.0* at the center and 275.1 at the east and west ends. There are 4-foot high steel railings along the upstream and downstream sides. Ten steel floor plates, 1 foot wide by 6.2 feet long*, are mounted in the deck surface to provide access to the flashboards. At the present time, they are welded shut.

The earth embankment consists of two sections, one on each side of the spillway. The east embankment, which is about 65 feet long, has a crest elevation of 274.6 at the edge of the spillway deck, sloping to El 272.5 where it abuts the natural ground surface (see Figures B-1, B-2, and B-3 in Appendix B). The grassed slopes are 6:1 and grade down to a toe elevation of about 271. A 3-foot diameter willow tree is adjacent to the spillway on the downstream face. A 4-foot high chain link fence is situated at the upstream edge of the crest.

The west embankment, which is about 135 feet long, has a crest El of 274.6 at the edge of the spillway and El 272.6 at the western end. The crest is about 7 feet wide and is covered by broken asphalt paving and sand and gravel. The upstream edge is bordered with concrete curbing, 1 foot thick and 130 feet long, which supports a 12-foot high chain link fence. The elevation of the top of the curbing is 0.35 feet above the elevation of the crest. The downstream face is grassy with about a 10:1 slope and a toe elevation of about 271. Another 3-foot diameter willow tree is growing adjacent to the spillway on the downstream face.

Steel sheeting of variable lengths is shown as cutoffs within the earth embankment (see Figures B-1 and B-2 in Appendix B). The installation of this sheeting is substantiated by previous inspection reports from the dam construction which mention driving sheeting to refusal.

*Indicates information derived from the Contract Drawings (Figures B-1, B-2, and B-3 in Appendix B) and not directly measured in the field.

Flow through the spillway and sluiceways discharges into a riprapped trapezoidal channel. The channel is about 1,200 feet long and 5.5 feet deep. The bottom width ranges from 110 feet at the spillway, to 77 feet at 270 feet downstream, to 36 feet at 1,200 feet downstream (see Figure B-4 in Appendix B). Water from the outlet channel flows into a concrete box culvert beneath East Main Street. The culvert opening is 7 feet wide by 14 feet high, with an invert elevation of 261.0. There is a flared approach channel to the culvert, which is 75 feet long and ranges from 35.5 feet wide at the upstream end to 14 feet wide at the culvert opening. The bottom of the approach channel is made of concrete, and the lower 61 feet is sloped at about 13:1. The approach channel and culvert are recessed below the surrounding ground level with concrete side-walls 1.5 feet thick. The elevation at the top of the sidewall is about 272.0 (see Figure B-4 in Appendix B).

- c. Size Classification. Cedar Swamp Pond Dam is classified in the "small" category, since it has a maximum height of 11 feet and maximum storage capacity of 600 acre-feet. Under normal conditions, however, the difference between pool and tailwater elevations is only about 3.5 feet, producing an effective storage above tailwater of only 280 acre-feet.
- d. Hazard Classification. The Town of Milford is 0.2 miles downstream from the dam. An outlet channel extends between the dam and a box culvert under Main Street. There are numerous residences and commercial property to the east, south and west of the outlet channel. A playground and baseball field also lie immediately west of the channel. In the event of dam failure under flood conditions few lives could be lost and much property damage could occur. Initially, the dam was classified in the "high" hazard category due to its proximity to the Town of Milford. However, after discussions with Corps of Engineers, the dam was reclassified to the "significant" hazard category.

- 111 .
- e. Ownership. The dam is presently owned by the Town of Milford. The Town Engineer, Mr. John Parmentier (617-473-3728) granted permission to enter the property and inspect the dam.
 - f. Operator. The Town does not operate the slide gates at the dam, nor are they operated by anyone else. The Town of Milford has the keys for the padlocks on the handwheels which operate the slide gates.
 - g. Purpose of the Dam. The reservoir is presently used for recreational purposes. The upstream area along the west shoreline is a park and picnic ground with a town-operated swimming pool adjacent to the pond. Water was being pumped from the pond to clean the pool on the day of inspection.
 - h. Design and Construction History. The dam was built in 1939 for the Town of Milford as a federal Public Works Administration project. We understand it was built to replace a previous dam located downstream at East Main Street where an old mill had been. The previous dam was damaged during the storm of 1938. There are no remnants of that structure visible today. It appears that the present dam was built essentially as shown on the Contract Drawings, except for minor changes such as additional chain link fencing and an asphalt paved walkway on the eastern section of the embankment crest, and a 12-foot high chain link fence and a berm at the top of the upstream face of the western embankment crest. Also, the upstream shorelines appear to be slightly different from the shoreline at El 270.1 shown on the drawings. These changes are shown on Figure B-1 in Appendix B. There is no record of when these changes were made or if any other modifications have been made.
 - i. Normal Operating Procedures. There are no normal operating procedures at the dam. The only apparent outlet controls for the dam are the two slide gates located at the east end of the spillway weir. These are operated by steel gate wheels mounted on a headwall on

the upstream face of the concrete service deck. There is a heavy duty chain and lock between each wheel and the steel railing on the deck.

The ogee-type spillway for Cedar Swamp Pond dam is ungated and flow is unrestricted. Removable flashboards are in place along the crest, but the Town has not removed them recently. Steel access plates in the surface of the service deck to be used for removal of the flashboards are welded shut.

1.3 Pertinent Data

- a. Drainage Area. The approximately 5,100 acre (8.03 square mile) drainage area above the dam consists of locally developed, mostly wooded and gently rolling land. There are two other ponds which drain into Cedar Swamp Pond. Louisa Lake dam is a flood control dam located 1,200 feet northwest of Cedar Swamp Pond. A new dam is currently being designed by the Massachusetts Department of Waterways for that location and will have a proposed spillway crest elevation of 284. Echo Lake dam is located 12,000 feet north of Cedar Swamp Pond and is a water supply reservoir. It is shown on the United States Geological Survey (USGS) topographic map as having a pond surface elevation of 347.0.
- b. Discharge at Dam Site. Normal discharge above El 269.3 from the pond is over the flashboards on the spillway crest. The spillway is approximately 93.3 feet long.

Normal flow discharges from the spillway and both sluiceways into an earth channel lined with riprap. The channel is about 1,200 feet long and 5.5 feet deep. The bottom width varies from 110 feet at the dam to 36 feet at the downstream end. The side slopes are 2:1. A typical cross section is shown on Figure B-4 in Appendix B. The bottom of the channel slopes at approximately 0.5 percent downstream.

Flow from the channel discharges into an approach channel and box culvert. The approach channel is 75 feet long and narrows from 36 to 14 feet in width. The channel is made of concrete sidewalls and a sloped concrete bottom (see sketches of culvert on Figure B-4 in Appendix B). The culvert opening is 7 feet high by 14 feet wide. It is a concrete box culvert which extends 800 feet downstream. The flow continues into a series of channels and culverts for another 2,200 feet before entering the natural streambed of the Charles River.

The spillway can discharge an estimated 2,840 cfs at El 272.5 which is the minimum top of the dam. The spillway is adequate to contain an inflow test flood of 3,513 cfs (half of the probable maximum flood) without significantly overtopping the main dam.

The maximum flood at the dam site is unknown, however, Mr. Wallace Lindquist, retired engineer of the Worcester County Engineer's office stated that the dam did overtop in the storm of 1955. This was confirmed by a resident of the house at the left abutment who stated that the dam has overtopped in the past.

c. Elevation (feet above MSL (Mean Sea Level)).
The assumed benchmark elevation of 275 on the top of the deck over the spillway is based on information as shown on Figure B-1.

- (1) Top dam: Concrete deck over spillway - 275.0 to 275.1; Earth embankment - 272.5 to 274.6.
- (2) Maximum pool-design surcharge: 272.5
- (3) Full flood control pool: Not Applicable (N/A)
- (4) Recreation pool: 269.3
- (5) Spillway crest (ungated): 268.5, top of flashboards 269.3.

(6) Upstream portal invert diversion tunnel:
N/A

(7) Stream bed at centerline of dam: 264

(8) Tailwater (Sluice gates closed): 265.8

d. Reservoir

(1) Length of maximum pool: 4,500 feet

(2) Length of recreation pool: 4,500 feet

(3) Length of flood control pool: N/A

e. Storage (acre-feet)

(1) Recreation pool: 400 (approximate)

(2) Flood control pool: N/A

(3) Design surcharge: 320 at El 272.5
(approximate - without flashboards)

(4) Top of dam: 720 (approximate)

f. Reservoir Surface (acres)

(It is assumed that an increase in elevation from 268.5 to 272.5 will not significantly increase the surface area of the pond.)

(1) Top dam: 80

(2) Maximum pool: 80

(3) Flood-control pool: N/A

(4) Recreation pool: 80

(5) Spillway crest: 80

g. Dam

(1) Type: earthfill embankment

(2) Length (embankment): 200 feet

(3) Height: 8 feet

- (4) Top width: 8 to 10 feet
- (5) Side slopes: Upstream face of west embankment 1.7:1; other slopes 6:1 to 10:1.
- (6) Zoning: Unknown
- (7) Impervious core: Steel sheeting of variable length and depth; design cutoff for top of sheeting at El 272.0.
- (8) Cutoff: Steel sheeting driven to refusal.
- (9) Grout curtain: None shown on drawings.

1. Spillway

- (1) Type: Ogee
- (2) Crest length: 93.3 feet
- (3) Crest elevation: 268.5 MSL
269.3 MSL (top of flashboards)
- (4) Gates: None
- (5) Upstream Channel: None
- (6) Downstream Channel: 1,200 foot long by 5.5 foot deep earth channel lined with riprap. Bottom width varies from 110 feet at the dam to 36 feet at the downstream end. Flow continues downstream through a concrete box culvert 7 feet high by 14 feet wide with an invert elevation of 261.0.

- j. Regulating Outlets. The only apparent regulating outlets are two steel slide gates 4 feet by 4 feet square. The gates are operated by wheels mounted on the upstream face of a headwall which extends to an overhead service deck. The sluice gates are not operated on a regular basis. Flow from the sluiceways joins the downstream channel of the spillway.

SECTION 2
ENGINEERING DATA

- 2.1 General. There are three sheets of Contract Drawings and one sheet of hydraulic calculations available for the dam from the Worcester County Engineer's office. Copies are included in Appendix B. The only other data used for this evaluation were visual observations during inspection, review of previous inspection reports and conversations with the Owner and personnel from Town, State and County agencies.

The assessment of the condition of the dam must be based primarily on the visual inspection, review of available data, and the past operational performance of the structure.

We acknowledge the assistance and cooperation of personnel of the Massachusetts Department of Public Works: Messrs. Willis Regan and Raymond Rochford, and personnel of the Massachusetts Department of Environmental Quality Engineering, Division of Waterways: Messrs. John J. Hannon and Joseph Iagallo.

Also, we acknowledge the cooperation and assistance of personnel from the Worcester County Engineer's Office: Messrs. John O'Toole, Joseph Brazauskas, and Mr. Wallace Lindquist - recently retired from county service.

In addition, we thank Mr. John Parmentier, Town Engineer of Milford, and Mr. Martin Goldstein, Assistant Planner for the Town of Milford, who allowed us to inspect the dam and arranged to have the slide gates opened during the inspection.

- 2.2 Construction Records. The only available construction records are the Contract Drawings dated 1938, given in Appendix B.
- 2.3 Operation Records. No operation records are available for the dam. No daily record is kept of pool elevation or rainfall at the dam site.
- 2.4 Evaluation of Data. The data acquired are considered adequate for this Phase I Inspection and Evaluation.

SECTION 3
VISUAL INSPECTION

3.1 Findings

- a. General. The Phase I inspection of the dam at Cedar Swamp Pond was performed on June 14, 1978. A copy of the inspection report is included in Appendix A. Periodic inspections of this dam by others have been made since 1938. A listing of these inspections is in Appendix B. An inspection was made in January, 1972, by personnel from the Massachusetts Department of Public Works. A copy of this report is included in Appendix B.

- b. Dam. The dam consists of an earthfill embankment with a concrete spillway. Photographs in Appendix C show the embankment areas. Erosion was observed at several locations along the embankment. The most serious of these was a washed out area located 65 feet west of the spillway on the upstream edge of the embankment. The washout is about 2 feet wide and 1 foot deep and has eroded beneath the concrete curbing. Several pieces of riprap have been dislocated. Minor erosion of soil has also occurred adjacent to the spillway sidewalls beneath the pavement on the crest of both abutments.

Trees and brush are growing on parts of the embankment slopes. A 36-inch diameter willow tree is growing on each abutment adjacent to the spillway on the downstream slope. Some roots can be seen at the surface growing into the concrete sidewalls. On the upstream slope west of the spillway, brush and grass are growing on the riprap. Tree roots can be seen growing between the blocks of riprap.

The asphalt pavement on the embankment crest west of the spillway is broken and in poor condition. Pieces are missing in places, exposing the underlying soil. This walkway is heavily used by recreational visitors.

- 17/11
- c. Appurtenant Structures. The concrete in the spillway and sluiceways is generally in good condition, except for slight erosion at the base of the piers, on the weir face, and at the water line of the sidewalls. Local spalling of the concrete has occurred at the downstream corner of the pier at the east end of the spillway and along the water line of the pier dividing the two sluiceways. There is a discoloration of the concrete along the water line, but this does not appear to be due to rusting of reinforcing steel. Slight seepage was seen along a horizontal crack (probably a joint) on the east face of the pier between the spillway and sluiceways. Minor cracking was noted in the concrete sidewalls.

The concrete service deck is in good condition. The steel railings and the gate wheels need painting. The access plates to the flashboards on the spillway weir are welded shut.

- d. Reservoir Area. The area immediately around the reservoir is well populated and contains several businesses. The drainage area as a whole, however, is mostly rural, sparsely populated and wooded. However, the area is presently experiencing some development. An average slope in the watershed is estimated to be about one percent.
- e. Downstream Channel. Discharge from the spillway and sluiceways flows into a riprapped channel which discharges into a concrete box culvert, 1,200 feet downstream. The downstream channel is lined with unchinked riprap on the side slopes. The side slopes are 2:1 and the bottom slopes downstream are about one percent. The channel slopes and bottom are heavily overgrown with brush and weeds.

The box culvert downstream of the channel is constructed of concrete with concrete sidewalls and a sloping approach channel. The concrete is generally in good condition. There is slight erosion of the bottom of the sloped section of the approach channel, where the velocity of flow is probably greater.

3.2 Evaluation. Cedar Swamp Pond dam appears to be in good condition with no visible signs of structural distress. However, repairs are needed at the present time and a program of periodic inspection, operation, and maintenance should be undertaken. Remedial measures to improve these conditions are stated in Section 7.3.

SECTION 4

OPERATING PROCEDURES

- 4.1 Procedures. There are no operating procedures at this dam. Members of the Town Engineering, Planning, Fire and Highway Departments were present on the day of the inspection. However, no one knew if the dam had ever been operated by the Town or by others. The slide gates were opened by the Town for inspection, otherwise they are closed. The flashboards were in place and there was no information available as to when they were installed except as noted on an inspection report in 1958.
- 4.2 Maintenance of Dam. The dam is not regularly maintained. The locks on the slide gate wheels were replaced on the day of the inspection as they were inoperable.
- 4.3 Maintenance of Operating Facilities. The slide gates were opened and closed on the day of inspection. The flashboards were not examined in detail because the access plates in the deck surface were welded shut.
- 4.4 Description of Any Warning System in Effect. There are no warning systems in effect at this dam.
- 4.5 Evaluation. There are no operating, maintenance, or warning systems in effect at Cedar Swamp dam. This is undesirable considering the fact that it is in the "significant" hazard category. A program of periodic maintenance for this dam should be implemented. The slide gates should be operated periodically and the access plates in the concrete deck should be reopened and bolted in case the flashboards need to be removed in the future.

SECTION 5

HYDRAULIC/HYDROLOGIC

5.1 Evaluation of Features

- a. Design Data. The Probable Maximum Flood (PMF) was determined to be 850 cfs per square mile. This calculation is based on the average drainage area slope of 1.1 percent, on the pond-plus-swamp-area to drainage-area ratio of 10 percent, and on the U.S. Army Corps of Engineers' guide curves for Maximum Probable Flood Peak Flow Rates (dated December 1977). Applying one-half the PMF to the 8.03 square miles of drainage area results in a calculated peak flood flow of 3,513 cfs as the inflow test flood. By adjusting the inflow test flood for surcharge storage, the maximum discharge rate was established as 3,110 cfs, with a water surface at El 272.75.

Since the lowest point on the dam crest is El 272.5, nearly the entire flow will be over the spillway. The maximum head on the spillway crest without flashboards would be 4.25 feet at a discharge of 33.3 cfs per foot of width. Flow over the dam crest would occur only at the extreme east and west ends with a maximum head of 0.25 feet.

Hydraulic analyses indicate that the existing spillway without flashboards can discharge a flow of 2,840 cfs at El 272.5. This is adequate to pass the 100-year storm outflow which is calculated to be about 1,230 cfs at El 270.80.

An evaluation was made of the hydraulic capacity of the box culvert 1,200 feet downstream from the dam. Based on preliminary information, the water surface elevation at the culvert entrance rises rapidly with increasing flow. Backwater in the channel between the culvert and the dam will impede the flow over the spillway at a discharge of 1,600 cfs and will submerge the spillway at flows of 1,700 cfs. This is substantially

less than the outflow test flood of 3,110 cfs. The spillway would not be submerged by the 100-year storm outflow of 1,230 cfs.

As noted above, the relationship between tailwater level and discharge rate is based on limited survey information. However, the basic validity of this relation is shown in Corps of Engineers study titled: "Charles River Watershed - Natural Valley Storage Project - Design Memorandum No. 1" dated May 1976. Plate 14 shows the flood profiles for river miles 70 to 80. From these profiles, it will be noted that for flood flows, the Main Street Bridge controls pond levels and that, hydraulically, the Cedar Swamp Pond dam is insignificant.

- b. Experience Data. The maximum flood at the dam site is unknown; however, Mr. Wallace Lindquist, retired engineer of the Worcester County Engineer's office, stated that the dam did overtop in the 1955 storm. This was confirmed by a resident of the house at the left abutment who stated that the dam has overtopped in the past.
- c. Visual Observations. The concrete ogee spillway for Cedar Swamp Pond is ungated and flow is unrestricted. Eleven (11) inch removable flashboards are in place along the dam crest. However, the access plates to the flashboards are welded shut and the flashboards cannot easily be removed. Also the eye bolts for the flashboards are missing. The general condition of the spillway is good except for some minor concrete spalling.
- d. Overtopping Potential. Overtopping of the dam is not expected under the inflow test flood of 3,513 cfs; as noted previously, however, the available information indicates that the dam was overtopped during the 1955 floods. Preliminary computations and information by others indicate that the overtopping of the dam is actually submergence caused by the backwater effect of the culvert under Main Street. It is unlikely that flooding

produced by this backwater could cause the
loss of more than a few lives or much property
damage.

SECTION 6

STRUCTURAL STABILITY

6.1 Evaluation of Structural Stability

- a. Visual Observations. The evaluation of the structural stability of Cedar Swamp Pond Dam is based on the visual inspection of June 14, 1978. As indicated in Section 3, Visual Inspection, there are several parts of the dam which should be repaired.

Based on these observations, Cedar Swamp Pond Dam appears to be in relatively good condition. Static stability conditions are probably satisfactory.

- b. Design and Construction Data. Three sheets of Contract Drawings for the dam were provided by the Worcester County Engineer's office. Copies are included in Appendix B. Information on the type, shear strength, and permeability of the soil and/or rock materials of the dam embankment does not appear to exist.

The earthfill section of the dam was probably constructed of local soil or rock materials. The cutoff for the dam is indicated as steel sheet piling. The spillway section was constructed of concrete. However, the strength or properties of the concrete are unknown.

- c. Operating Records. There is no evidence of instrumentation of any type in Cedar Swamp Pond Dam, and there is nothing to indicate that any instrumentation was ever installed in this dam. The performance of this dam under prior loading can only be inferred by previous records and physical evidence at the site.

- d. Post-Construction Changes. There are no as-built drawings for Cedar Swamp Pond Dam, however, it appears that the present dam was built essentially as shown on the Contract Drawings, except for minor surface modifications.
- e. Seismic Stability. This dam is located in Seismic Zone 2 and hence, does not have to be evaluated for seismic stability according to the USCE Recommended Guidelines.

SECTION 7

ASSESSMENT, RECOMMENDATIONS, AND REMEDIAL MEASURES

7.1 Dam Assessment

a. Condition

Examination of available information and visual inspection of the Cedar Swamp Pond dam indicate the dam is in good condition. Nevertheless, there are a number of problems which should be corrected to assure the continued performance of this dam. These include: local erosion of the dam slopes, large trees on the dam embankment, spalling of the spillway concrete, and an accumulation of weeds, soil and debris in the downstream channel. It was also noted that the access plates to the flashboards on the spillway deck are welded shut.

Hydraulic analyses indicate that the existing spillway without flashboards can discharge a flow of 2,840 cfs at El 272.5 which is the top of the dam. An inflow test flood of 3,513 cfs will not significantly overtop the main dam. Previous records at this site indicate the dam was overtopped in the 1955 floods. As discussed previously, computations and information by others indicate that the overtopping of the dam is actually submergence caused by the backwater effect of the culvert under Main Street.

- b. Adequacy of Information. The information available is such that the assessment of the condition of the dam must be based primarily on the visual inspection, the existing Contract Drawings, and past operational performance of the structure.
- c. Urgency. The recommendations outlined below should be implemented within 2-4 years after receipt of the Phase I Inspection Report.
- d. Need for Additional Information. Additional investigations to assess the adequacy of the dam and appurtenant structures do not appear necessary.

7.2 Recommendations. Cedar Swamp Pond Dam appears to be performing adequately and is in good condition. No recommendations for additional investigations are needed, based on the visual inspection and review of available data. Recommendations on repairs and maintenance procedures are stated below under 7.3 Remedial Measures.

7.3 Remedial Measures. The dam and appurtenant structures are not adequately maintained. It is recommended that the Owner accomplish the following items:

- (1) fill in areas of erosion on the dam embankment and protect with riprap or other suitable material;
- (2) remove the two large willow trees adjacent to the spillway; replant with other trees farther downstream if desired;
- (3) clear shrubs, brush, and grass from upstream face of dam embankment and clear weed growth from sides and bottom of downstream channel;
- (4) repair and resurface spalled and eroded portions of concrete in the spillway and sluice gate structures;
- (5) reopen access plates to flashboards and shut using bolts only;
- (6) install eyebolts on flashboards;
- (7) implement a systematic program of inspection and maintenance. As a minimum, the inspection program should consist of a monthly inspection of the dam and appurtenances and should be supplemented by additional inspections during and after severe storms. Operation of the slide gates should also be checked at least twice a year. All repairs and maintenance should be undertaken in accordance with all applicable State regulations.

APPENDIX A

Periodic Inspection Checklist

Page

A-1

PERIODIC INSPECTION

PARTY ORGANIZATION

PROJECT Cedar Swamp Pond Dam
Milford, Massachusetts

DATE June 14, 1978

TIME 8:00 AM - 5:00 PM

WEATHER partly cloudy, windy, 65°

W.S. ELEV. 269.2 U.S. 265.75 D.N.S.
assumed benchmark elevation
275.0 top of concrete deck

PARTY:

- | | |
|--|--|
| 1. <u>Richard G. Sherman</u> | 6. <u>Martin Goldstein, Assistant Planner,</u>
<u>Town of Milford</u> |
| 2. <u>Ed M. Greco</u> | 7. _____ |
| 3. <u>Lyle Branagan</u> | 8. _____ |
| 4. <u>Carol F. Sweet</u> | 9. _____ |
| 5. <u>John Parmentier, Town Engineer</u> | 10. _____ |

PROJECT FEATURE	INSPECTED BY	REMARKS
1. <u>dam - spillway</u>	<u>Richard Sherman</u>	
2. <u>downstream channel & culvert</u>	<u>Lyle Branagan</u>	
3. _____	_____	_____
4. _____	_____	_____
5. _____	_____	_____
6. _____	_____	_____
7. _____	_____	_____
8. _____	_____	_____
9. _____	_____	_____
10. _____	_____	_____

PERIODIC INSPECTION CHECK LIST

PROJECT Cedar Swamp Pond DATE June 14, 1978
 PROJECT FEATURE embankment NAME Richard Sherman
 DISCIPLINE geotechnical NAME _____

AREA EVALUATED	CONDITIONS
<u>DAM EMBANKMENT</u>	
Crest Elevation	varies from 272.5 to 274.6
Current Pool Elevation	269.2
Maximum Impoundment to Date	unknown
Surface Cracks	none visible
Pavement Condition	asphalt walkway pavement poor on west abutment; good on east abutment
Movement or Settlement of Crest	none visible
Lateral Movement	none visible
Vertical Alignment	relatively straight
Horizontal Alignment	relatively straight
Condition at Abutment and at Concrete Structures	minor erosion of soil beneath pavement at each abutment, downstream face
Indications of Movement of Structural Items on Slopes	none
Trespassing on Slopes	foot paths along upstream crest (west abutment) + along downstream sidewalls
Sloughing or Erosion of Slopes or Abutments	erosion of upstream slope 65' west of concrete deck; 3ft dia. willow tree on each abutment - roots to sidewalls
Rock Slope Protection - Riprap Failures	unchinked riprap on upstream face - some grass + brush growth
Unusual Movement or Cracking at or near Toes	none visible
Unusual Embankment or Downstream Seepage	none visible
Piping or Boils	none visible
Foundation Drainage Features	none visible
Toe Drains	unknown
Instrumentation System	none visible

PERIODIC INSPECTION CHECK LIST

PROJECT Cedar Swamp Pond DATE June 14, 1978
 PROJECT FEATURE spillway NAME Richard Sherman
 DISCIPLINE geotechnical NAME _____

AREA EVALUATED	CONDITION
<u>OUTLET WORKS - SPILLWAY WEIR, APPROACH AND DISCHARGE CHANNELS</u>	
a. Approach Channel	none
General Condition	N/A (not applicable)
Loose Rock Overhanging Channel	N/A
Trees Overhanging Channel	N/A
Floor of Approach Channel	N/A
b. Weir* and Training Walls	
General Condition of Concrete	good - slight erosion of crest, base of piers, and at water line of side walls.
Rust or Staining (discoloration)	slight along water line
Spalling	small piece from east corner spillway weir (pier #5)
Any Visible Reinforcing	none
Any Seepage or Efflorescence	none visible
Drain Holes	none visible
c. Discharge Channel	
General Condition	} same channel as outlet works
Loose Rock Overhanging Channel	
Trees Overhanging Channel	
Floor of Channel	
Other Obstructions	

* flashboards in place on top of spillway crest - 10" high, wooden - missing eye bolts for removal - plates for access on deck surface are welded shut.

PERIODIC INSPECTION CHECK LIST

PROJECT Cedar Swamp Pond DATE June 14, 1978
 PROJECT FEATURE sluiceway + slide gates NAME Richard Sherman
 DISCIPLINE geotechnical NAME _____

AREA EVALUATED	CONDITION
* <u>OUTLET WORKS - OUTLET STRUCTURE AND OUTLET CHANNEL</u>	
General Condition of Concrete	good
Rust or Staining (discoloration)	slight stain at water level
Spalling	slight around downstream face of pier at water line
Erosion or Cavitation	slight erosion on downstream face of pier next to spillway weir
Visible Reinforcing	none
Any Seepage or Efflorescence	slight seepage from joint on east face of pier next to weir
Condition at Joints	fair to good
Drain Holes	none visible
Channel	
Loose Rock or Trees Overhanging Channel	3' diameter willow tree on each side of channel at abutment
Condition of Discharge Channel	channel bottom choked with weeds + trash - rip rap in place channel sides overgrown with grass - rip rap in place

* Sluiceway and slide gates
 control:
 two 4-foot slide gates operated by hand wheels - good condition -
 made of steel

PERIODIC INSPECTION CHECK LIST

PROJECT Cedar Swamp Pond DATE June 14, 1978
 PROJECT FEATURE service deck NAME Richard Sherman
 DISCIPLINE geotechnical NAME _____

AREA EVALUATED	CONDITION
OUTLET WORKS - SERVICE BRIDGE	
a. Super Structure (concrete deck supported by concrete piers; deck has metal handrails along both sides)	
Bearings	none visible
Anchor Bolts	none visible
Bridge Seat	good
Longitudinal Members	none - concrete slab
Under Side of Deck	concrete in good condition
Secondary Bracing	none
Deck	concrete in good condition
Drainage System	none
Railings	need paint
Expansion Joints	good condition
Paint	needed on railings
b. Abutment and Piers	
General Condition of Concrete	good
Alignment of Abutment	good
Approach to Bridge	good - pavement on west abutment is broken + pieces missing; pavement on east abutment is good.
Condition of Seat and Backwall	concrete in good condition

Access plates to flashboards welded to frame

APPENDIX B
DAM PLANS AND PAST INSPECTION
REPORTS

	<u>Page</u>
General Plan of Dam, dated October 1938	In pocket
Miscellaneous Details, Part I, of Dam, dated October 1938	In pocket
Miscellaneous Details, Part II, of Dam, dated October 1938	In pocket
Details of Downstream Channel and Culvert	B-4
Previous Inspections (Partial Listing)	B-5
Inspection Report by Massachusetts Department of Public Works (January 11, 1972)	B-6
Fay, Spofford, & Thorndike Hydraulic Computations, dated October 19, 1938	B-7

Spacing as indicated
on Sheet No. 2

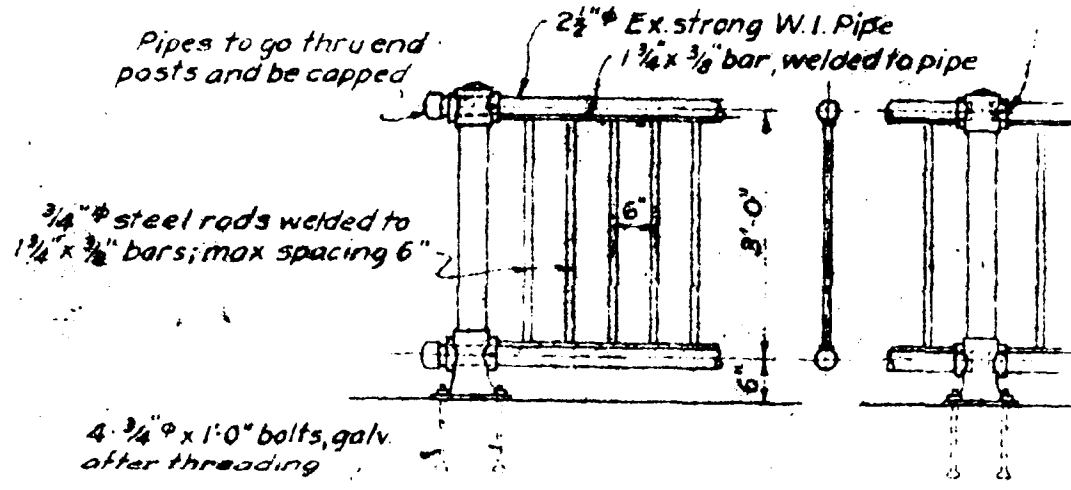

DETAIL OF METAL

SCALE 1/2" = 1'-0"

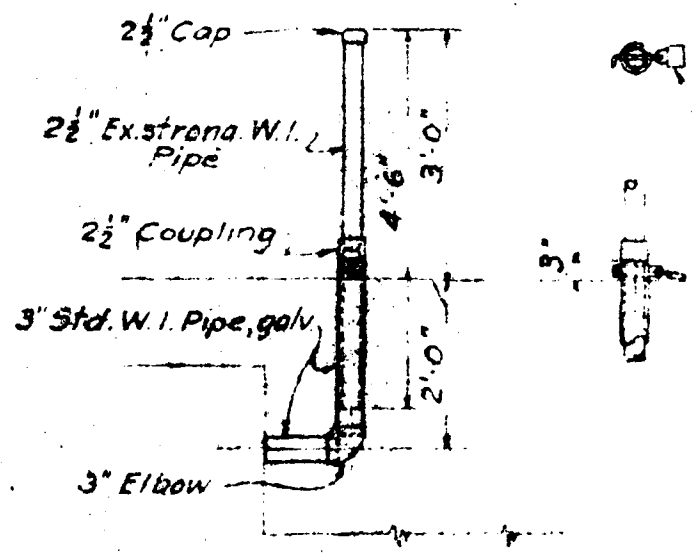

1 1/2" x 1/4" bent strap thru slots
in pipes, with weatherproof
padlock

DETAIL OF REMOVABLE POST

SCALE 1/2" = 1'-0"

272.5 x

Pipe pinned at one end only of each panel, with 3/8" c/s'k riveted pin. At sluice gates use bolts instead of pins.

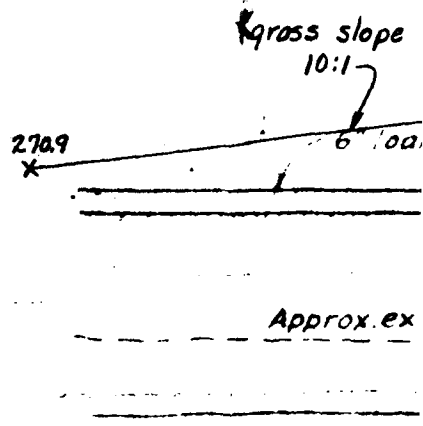
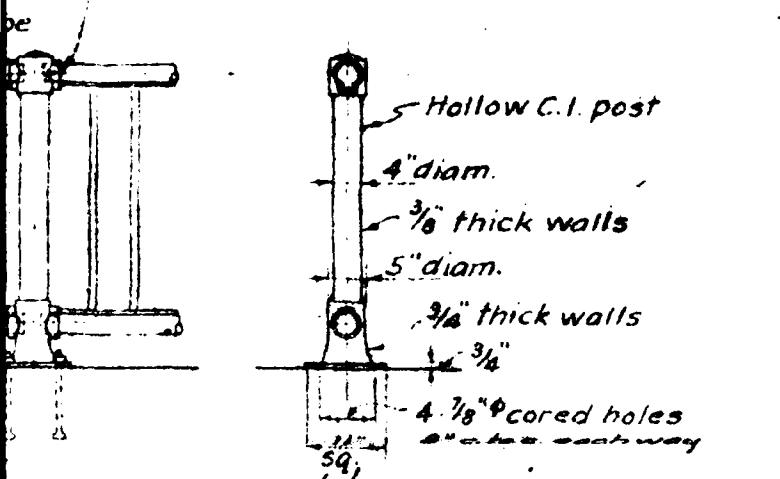

TAL RAILING

1'-0"

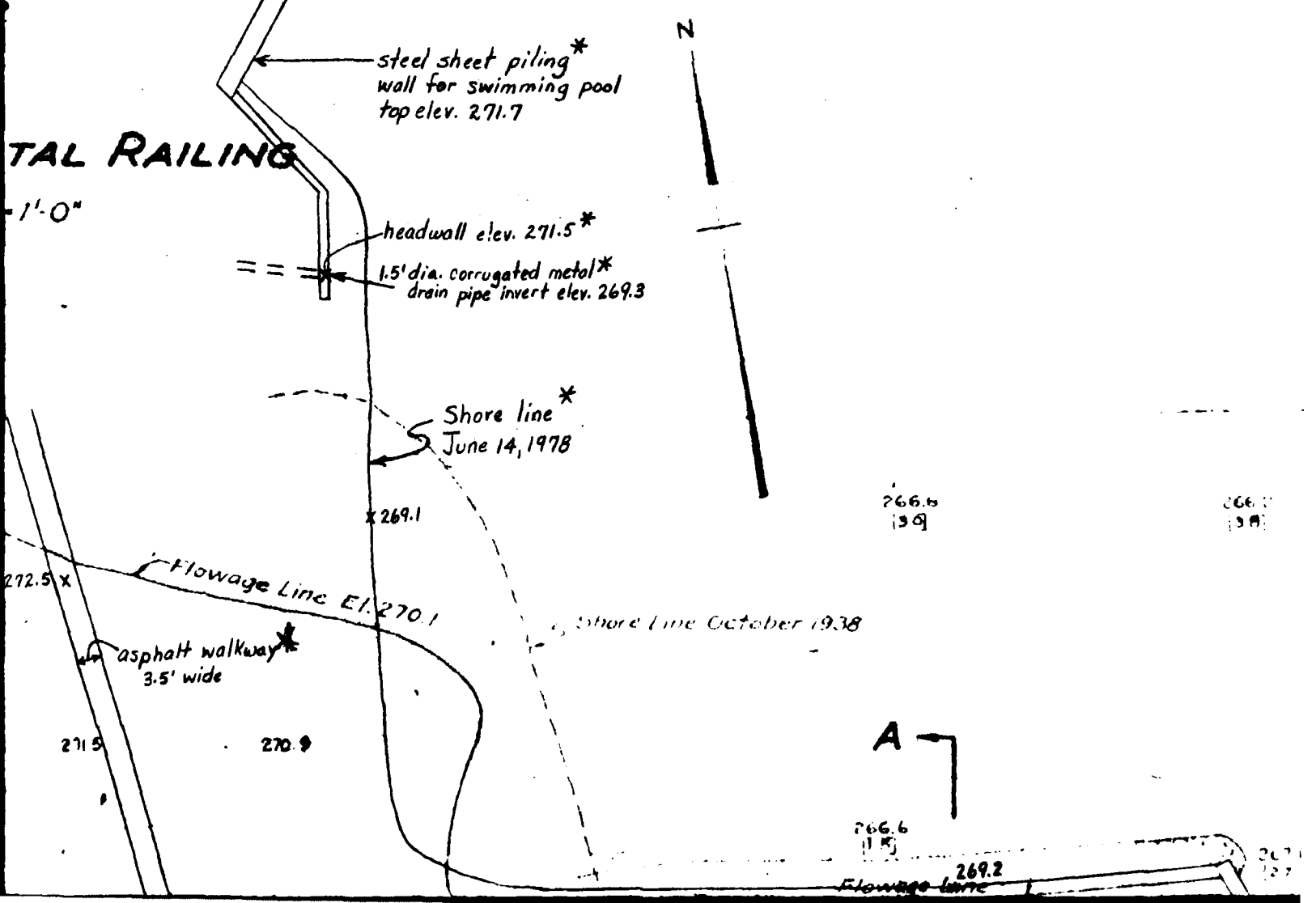

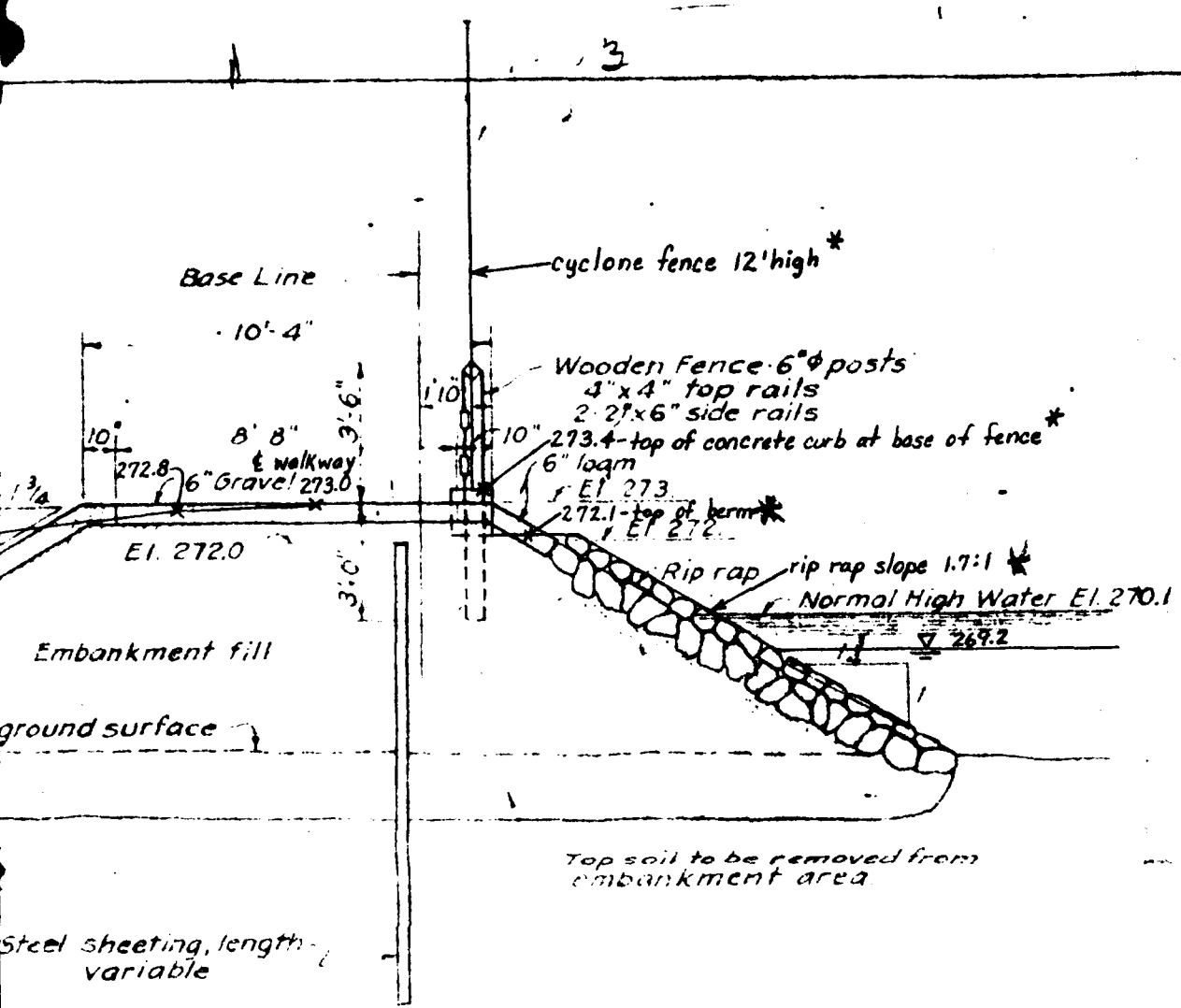

SECTION A-A

SCALE $\frac{1}{4}'' = 1'-0''$

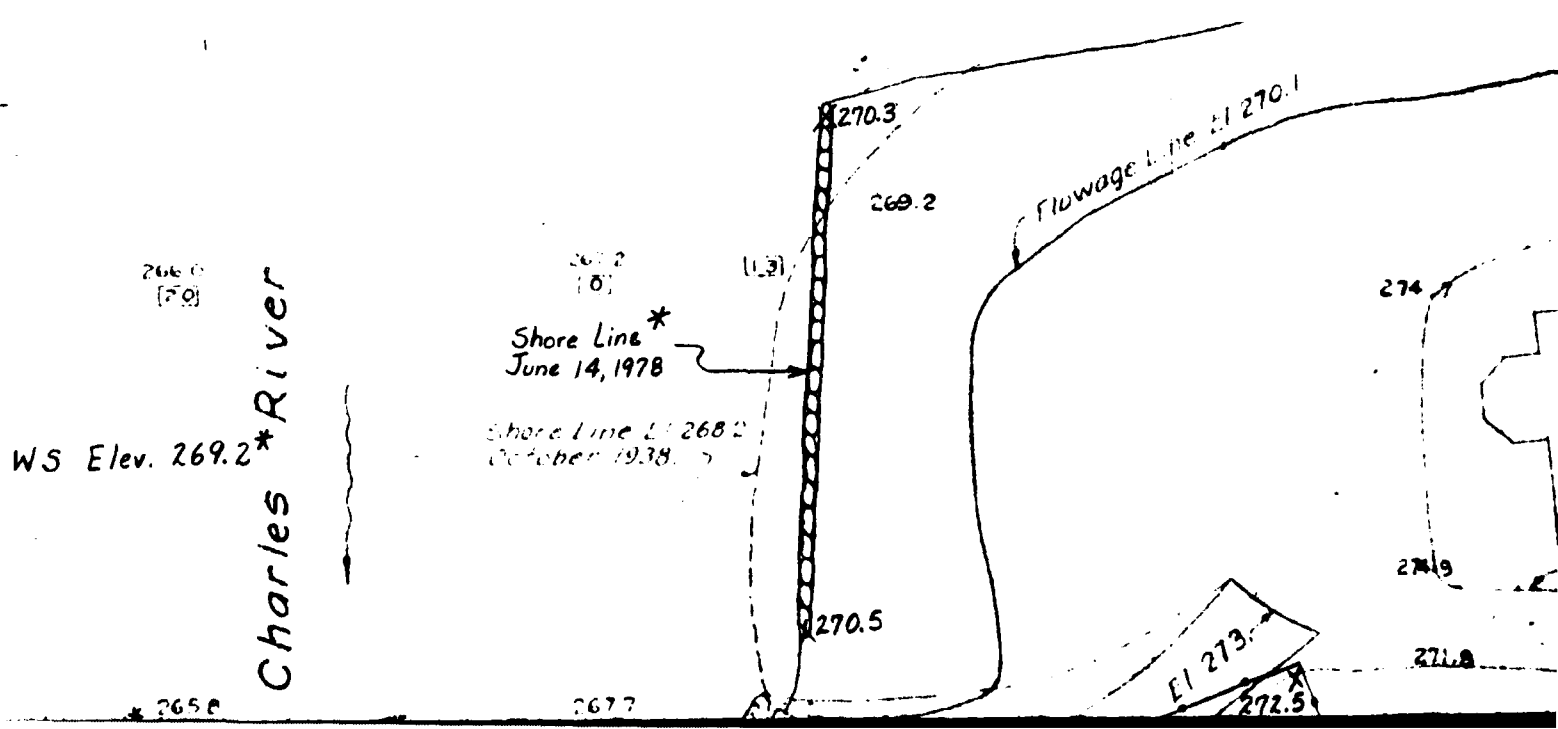

H

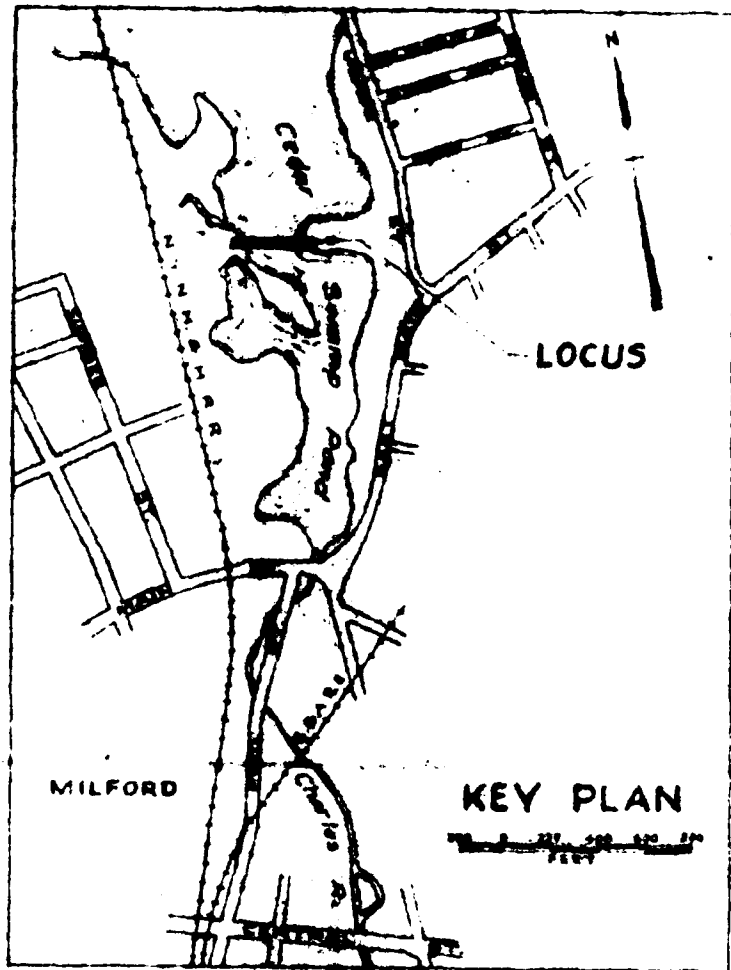

ce *

er El 270.1

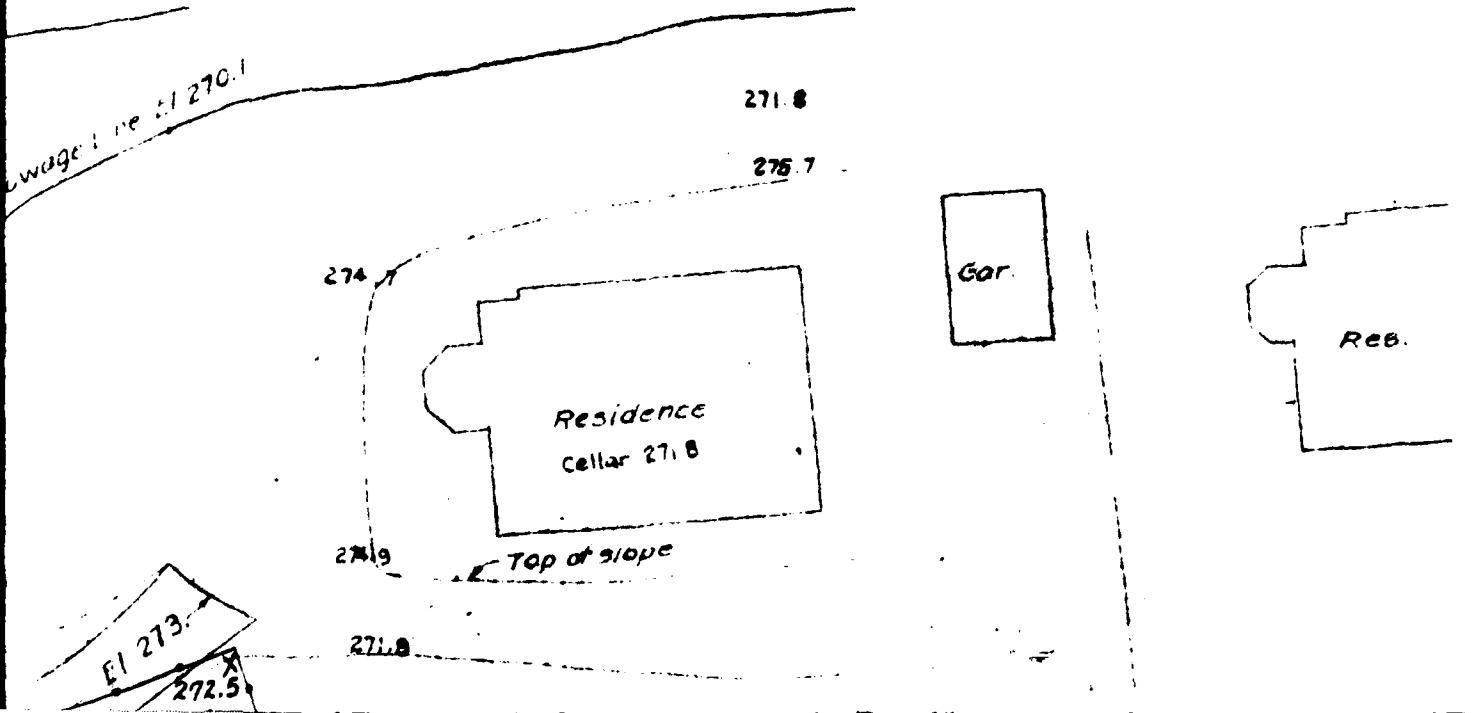

DETAIL OF REMOVABLE POST

SCALE $\frac{1}{2}'' = 1'-0''$

271.6

271.5

Base Line 1

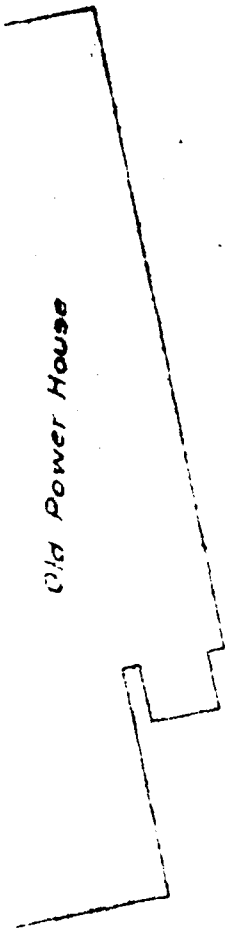

Old Power House

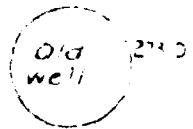

Old well

274.0

273.0

270

268.2

270.1

DIMENSIONS

Length 7'-6" Width 4'-6"

LETTERING HEIGHTS

Top Line 6 1/2" 2nd Line & 3rd Line 4 1/2" 4th Line 3" 5th Line 1 1/2"

P. W. A.

FEDERAL EMERGENCY
ADMINISTRATION OF PUBLIC WORKS

CEDAR SWAMP DEVELOPMENT

PROJECT NO. MASS 1446 F

P.W.A. PROJECT SIGN

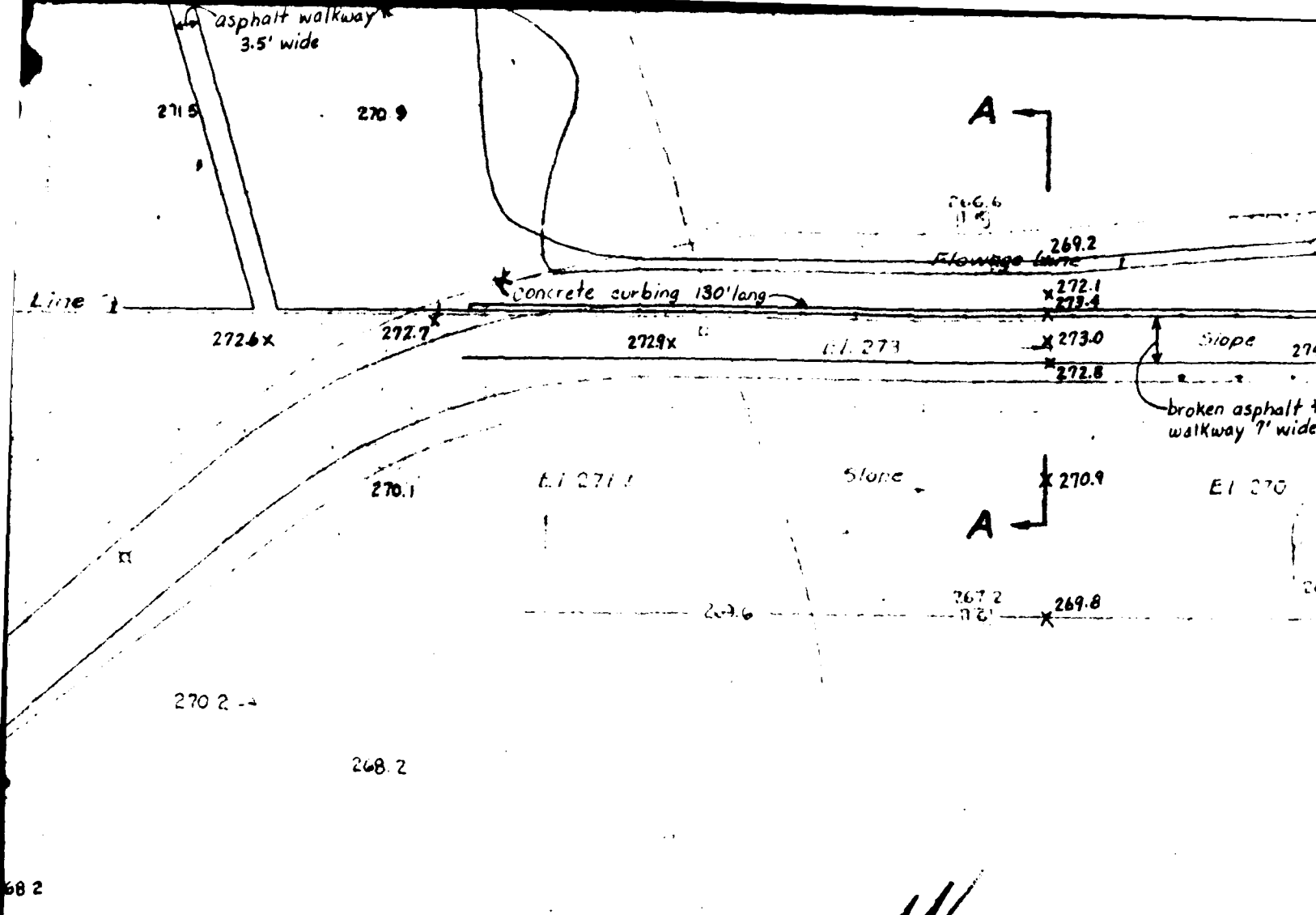

NOTES:

1. ELEVATIONS SHOWN WITH AN X WERE TAKEN DURING METCALF & EDDY FIELD INSPECTION OF JUNE 14, 1978
2. ASSUMED BENCH MARK ELEVATION OF 275 TO BE TOP OF CONCRETE DECK
3. * - NOTES ADDED BY METCALF & EDDY

A.
 EMERGENCY
 PUBLIC WORKS
 DEVELOPMENT
 5-1440 P

All Elevations
 Figures 5
 to 9 are in meters
 Location
 Elevation
 See Sheet

OBJECT SIGN

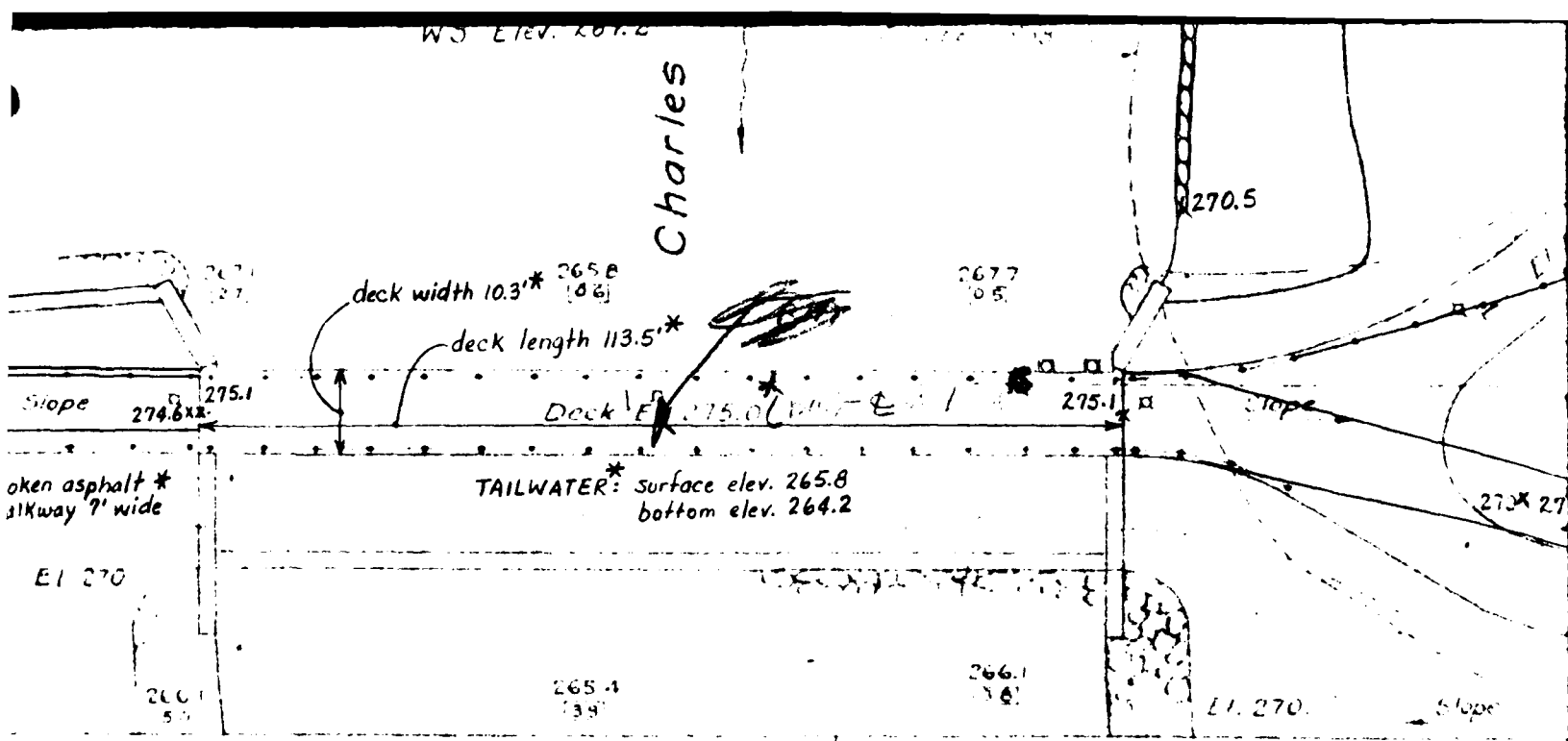

Extent of this Contract

GENERAL PLAN

SCALE 1" = 20'

- All Elevations are referred to Mean Sea Level.
- Figures shown thus (2.0) are depths from ground surface to material, as determined by punchings.
- Location of borings to be made are shown thus
- Existing ground surface elevations shown thus 265.4
- Elevations of finished work shown thus: El. 275.5
- See Sheets Nos 2 and 3 for Miscellaneous Details.

The approval of these Plans by the County Commissioners is of the Channel of the Charles River being the congested section of Milford P. W. A. Project sponsored by the Town.

The Gates of the present Cedar are to be removed at once for all

P.W.A. PROJECT NO. MASS
CEDAR SWAMP DEVELOPE
CONTRACT I

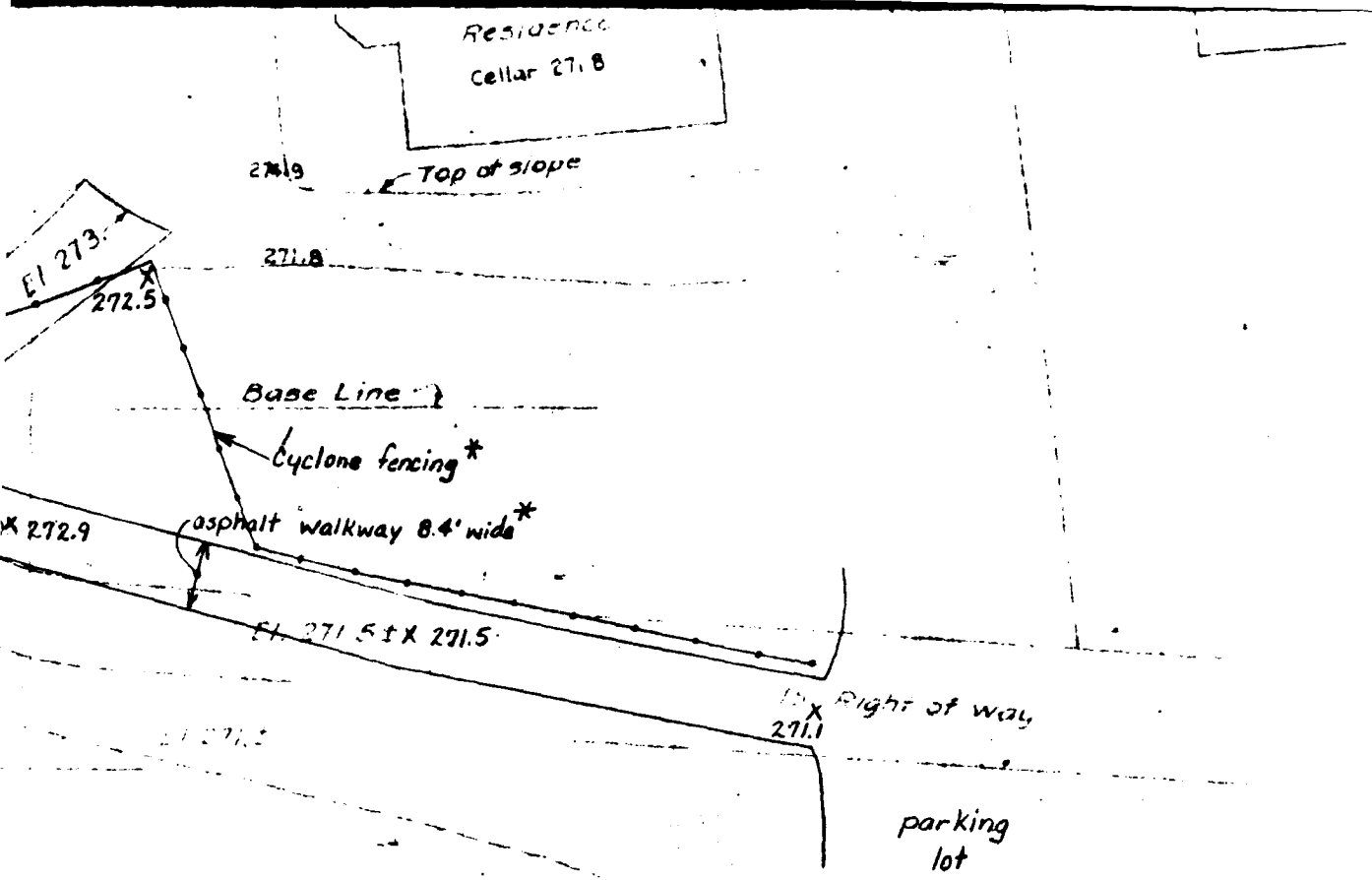

2663
[5]

WORCESTER COUNTY COMMISSIONERS
WORCESTER COUNTY ENGINEERING DEPARTMENT

GENERAL PLAN
OF DAM

AT CEDAR SWAMP POND
MILFORD, MASS.
FOR TOWN OF MILFORD

AS FILED AND APPROVED BY THE
COUNTY COMMISSIONERS

SCALES AS NOTED

Plans and Specifications
is contingent on the
being widened through
ford as part of a second
Town of Milford.

Cedar Meadow Pond Dam
all time.

Approved: <u>Dec 6, 1938</u>	Submitted for Approval: <u>Dec 6, 1938</u>
<u>Albert J. [Signature]</u> Chairman, Board of County Commissioners	<u>P.O. [Signature]</u> County Engineer
<u>George W. Jones</u> County Commissioner	FAY, SPOFFORD & THORNDIKE-ENGRS BOSTON, MASS. OCT. 1838
<u>Francis [Signature]</u> County Commissioner	DAM NO. 29-04.1

ASS. 1446-F
OPENMENT

CONTRACT DRAWING - SHEET NO. 1 OF 3

SCALE 3-1

[Signature]

Base Line
Gravel
Surface

Wooden Fence

Steel Railing see detail Sheet No. 1

EI. 275.0

ing - cut off EI 272)

ing ground surface

variable

Norm. H.W. EI. 270

Crest EI

EL

ne EI 270.1

30°

19' 4"

20' 0"

109' 8"

20' 0"

Pier No 1

Pier No. 2

1' 4"

18' 8"

1' 4"

Wooden Fence

Sheeting to be
ed by the Engineer

B

slope

EI. 275

Wooden Fence

EI 270

Const. level

Rip Rap

Rip Rap

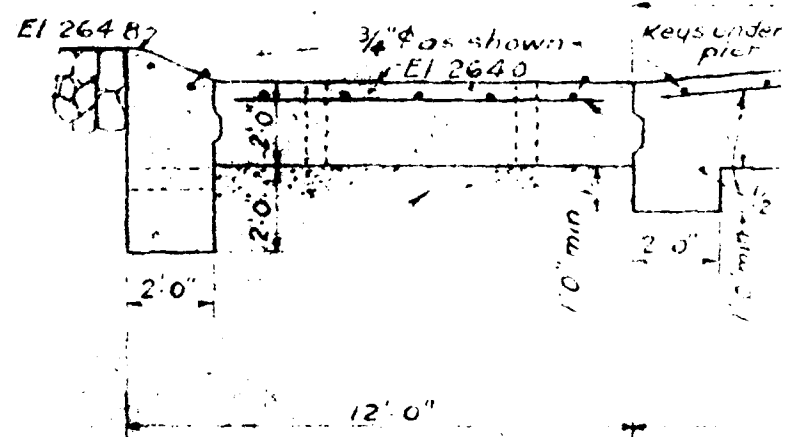
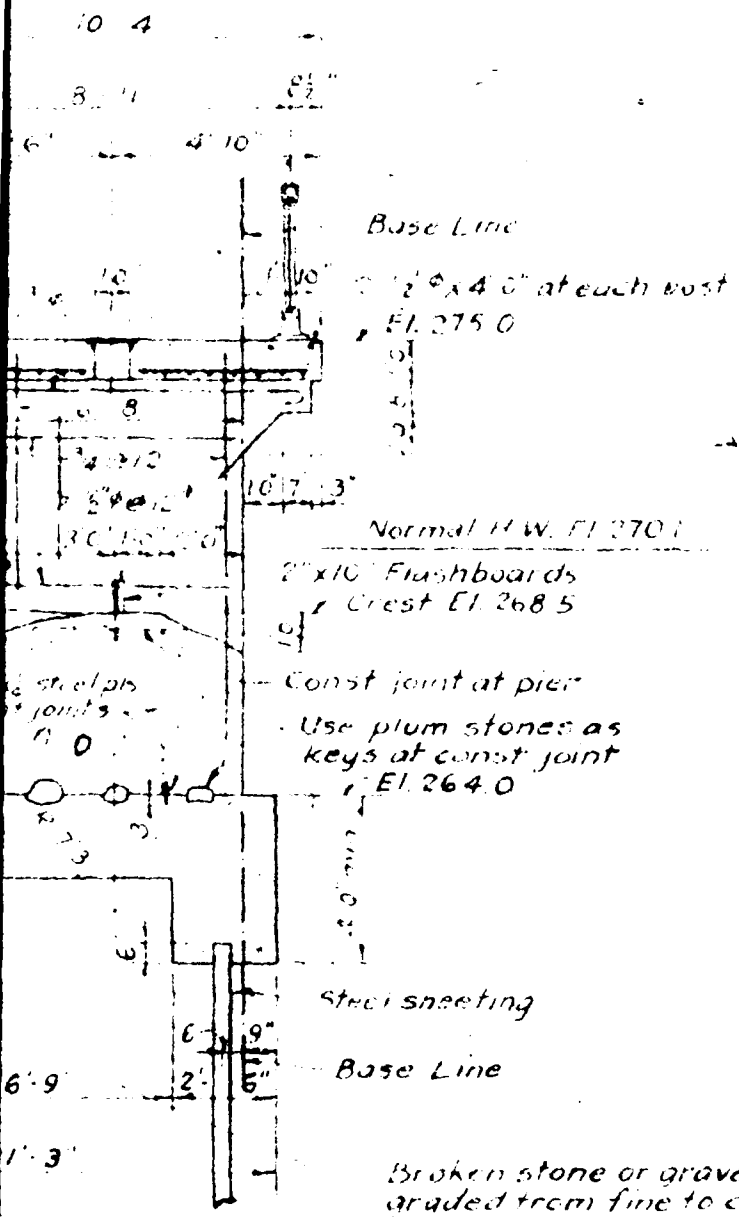

SE

El. 270

Existing
Grade El. 271.5'

Top of slope

N

WORCESTER COUNTY COMMISSIONERS
 WORCESTER COUNTY ENGINEERING DEPARTMENT
 PLAN OF
 MISCELLANEOUS DETAILS, PART I
 OF DAM
 AT CEDAR SWAMP POND
 MILFORD, MASS.
 FOR TOWN OF MILFORD
 AS FILED AND APPROVED BY THE
COUNTY COMMISSIONERS
 SCALES AS NOTED

one
 nc
 ough
 cond
 d.
 Dam

Approved: *Dec. 2, 1924*
Elbert M. Brackett
 Chairman, Board of County Commissioners
George W. Jones
 County Commissioner
Francis C. Cassidy
 County Commissioner

Submitted for approval
Dec. 6, 1924
W. H. Gardner
 County Engineer
 WORCESTER COUNTY ENGINEERING DEPARTMENT
 BOSTON, MASS. DEC
 DAM NO. 28-24

CONTRACT DRAWING

8

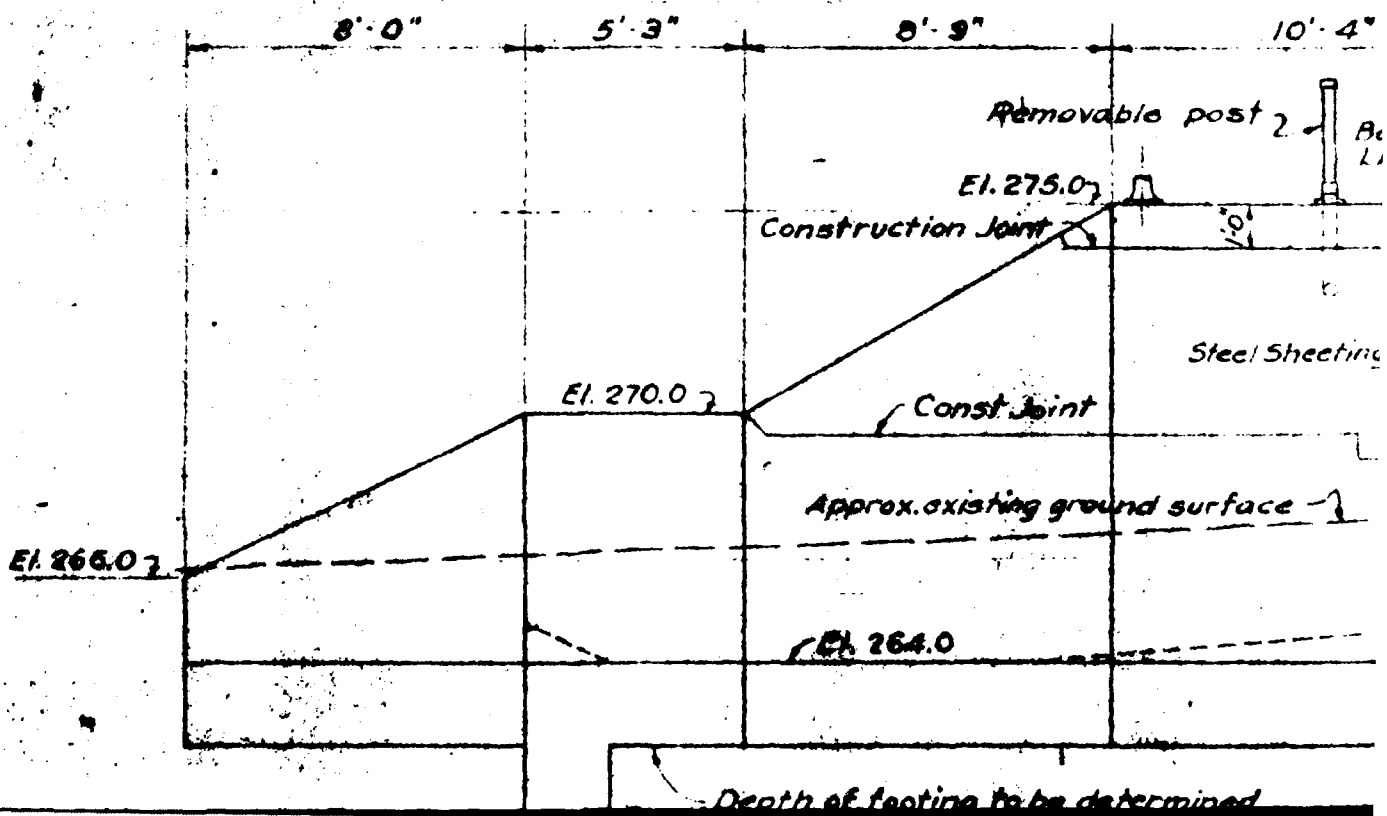
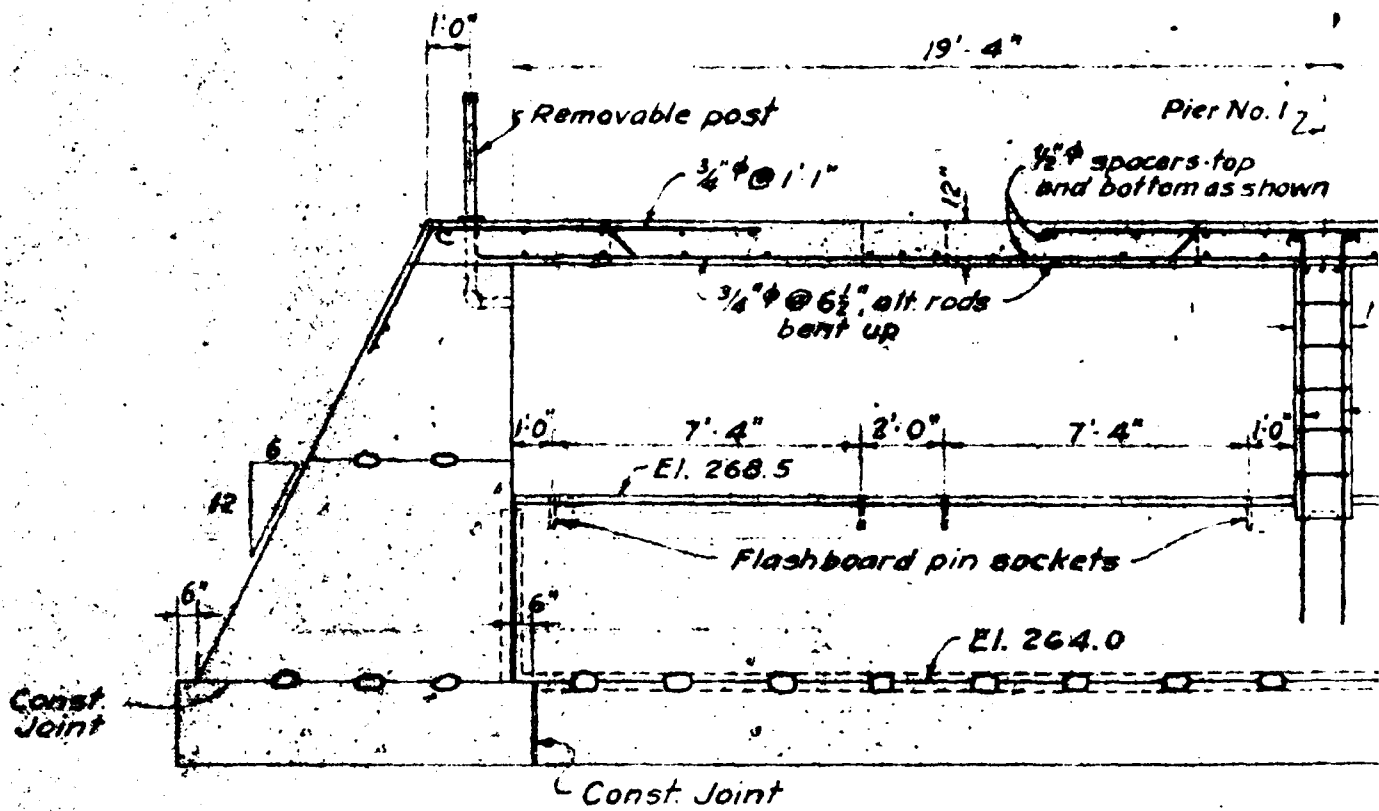

Note: Pier No 2 is opposite hand to Pier No. 4

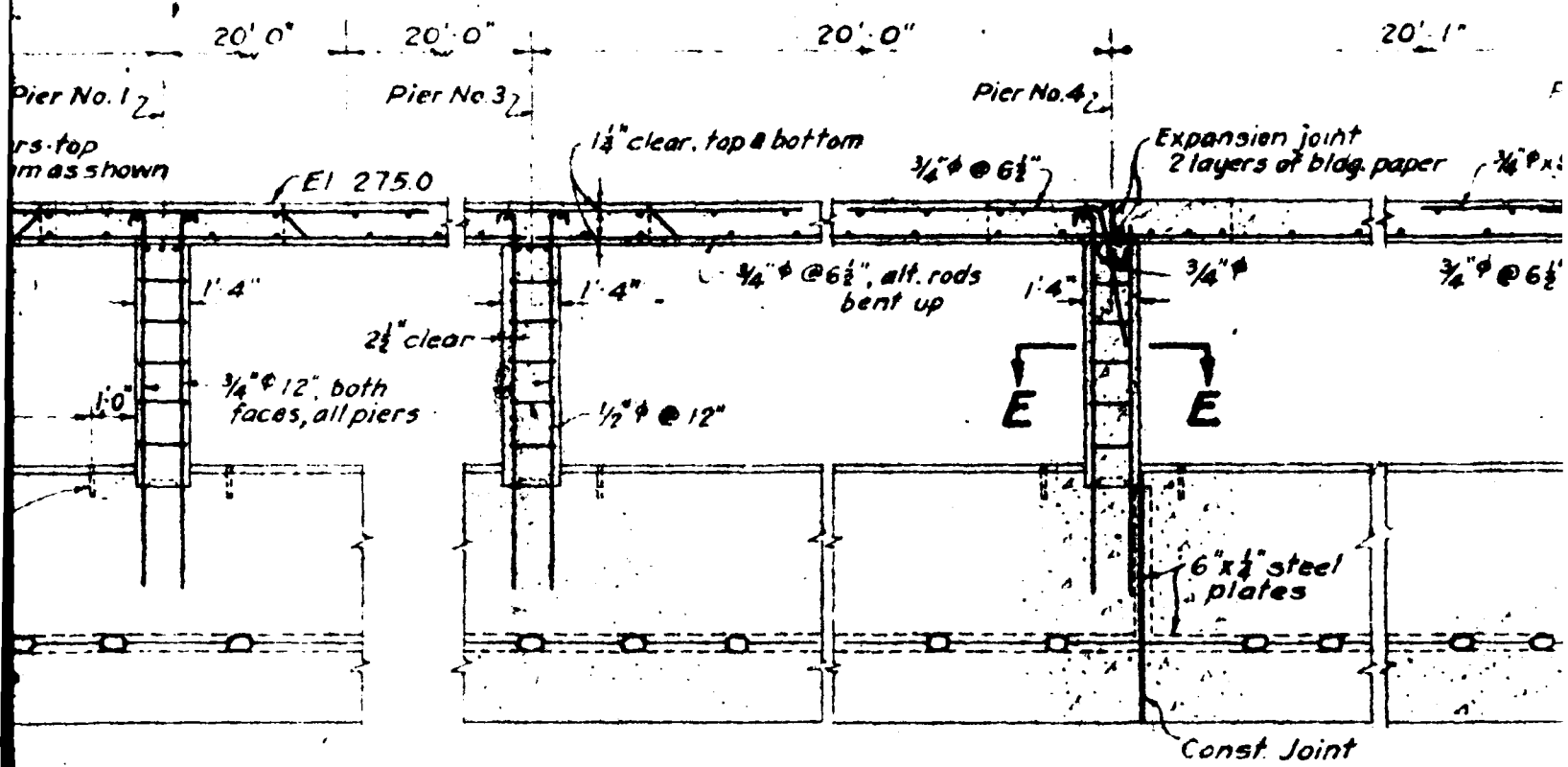

SECTION B-B

SCALE $\frac{1}{4}'' = 1'-0''$

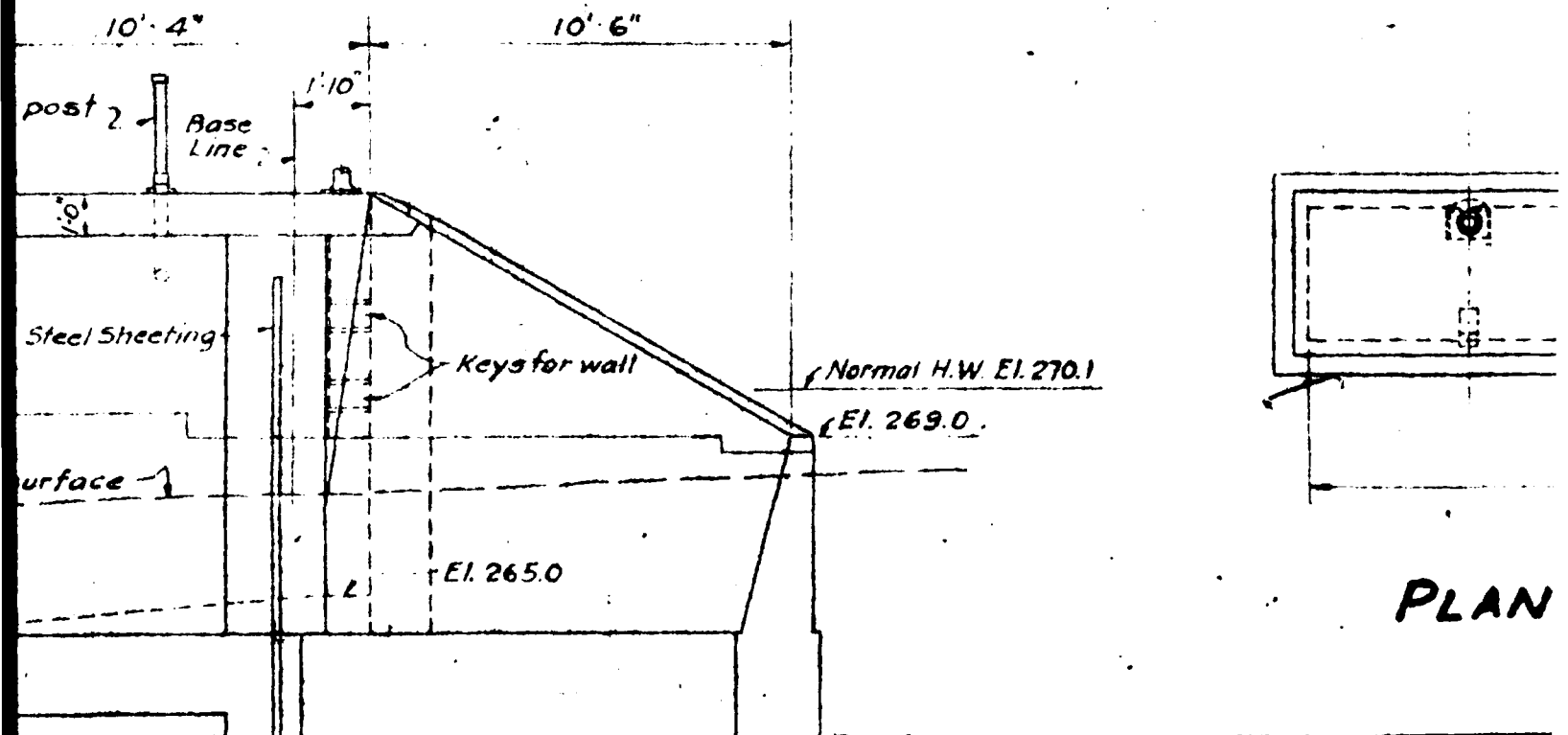

PLAN

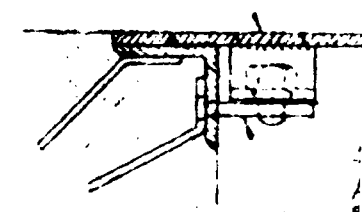
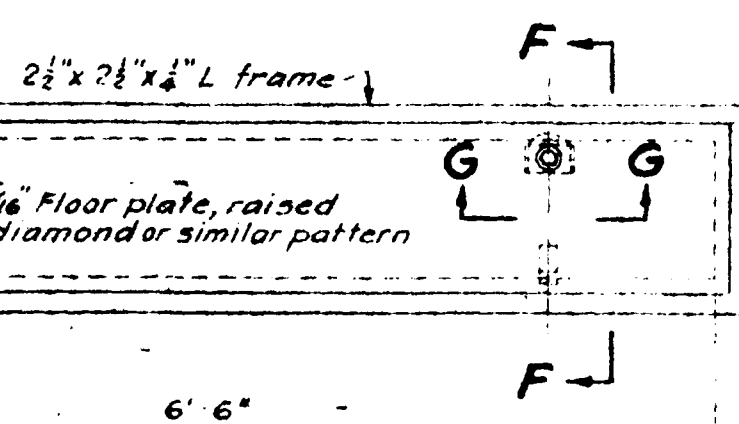
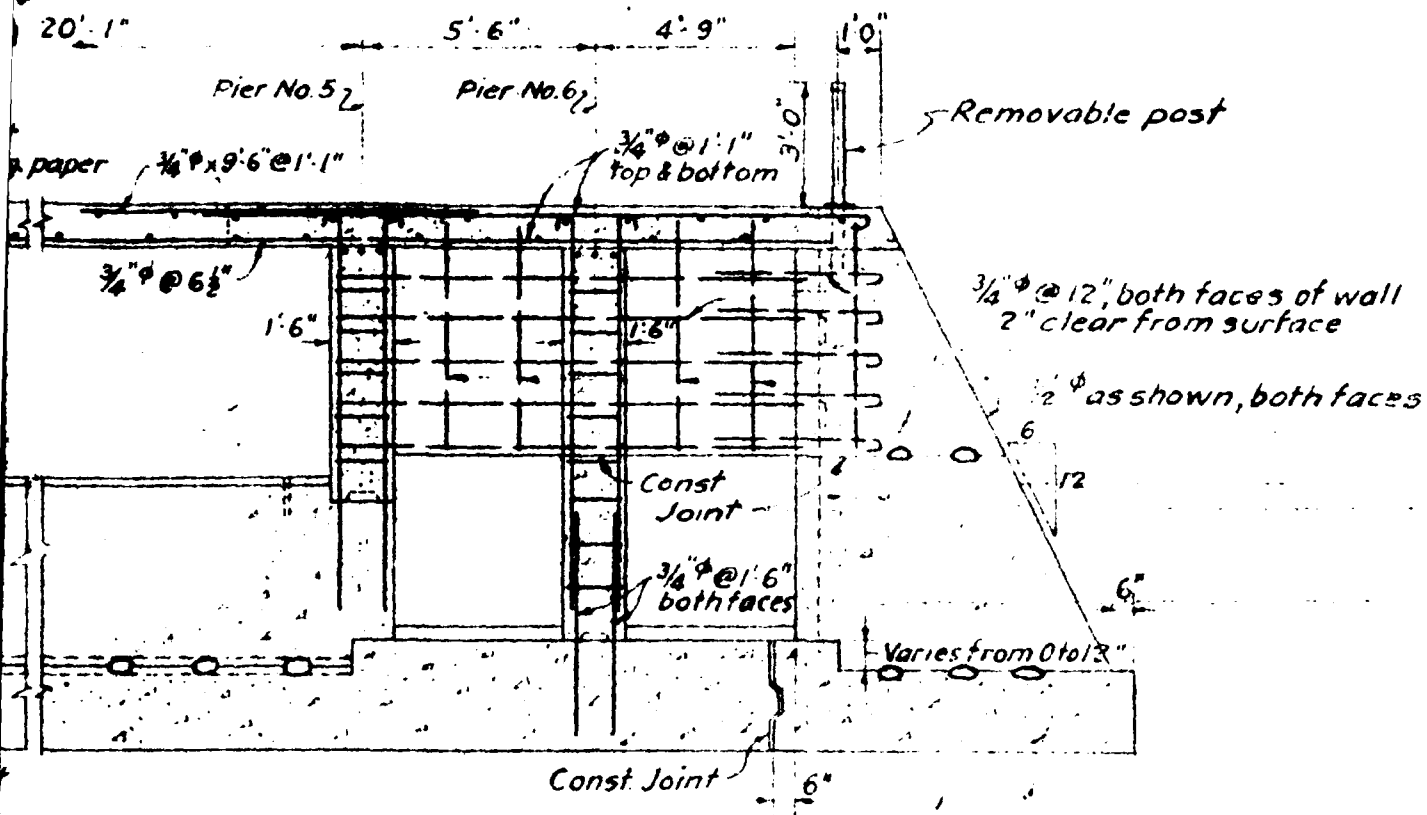

PLAN OF FLOOR PLATE ON BRIDGE

SE

SCALE 1" = 1'-0"

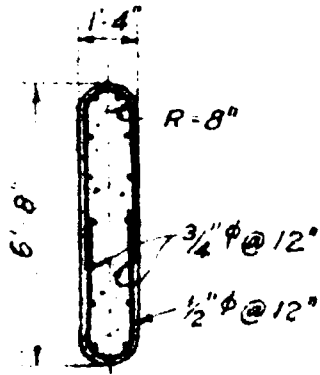

SECTION E-E

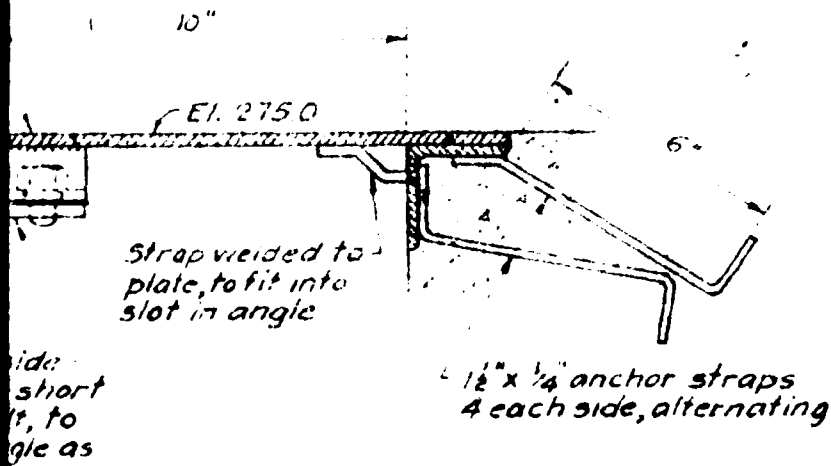

SECTION F-F



SECTION G-G

SCALE 3" = 1'-0"

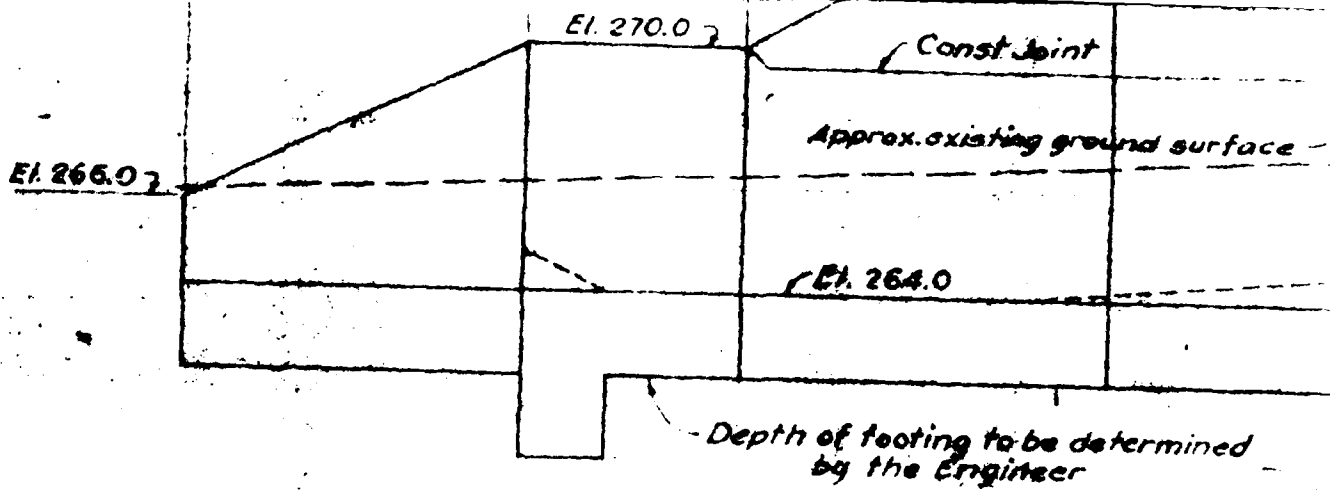

ELEVATION OF EAST
LOOKING WEST

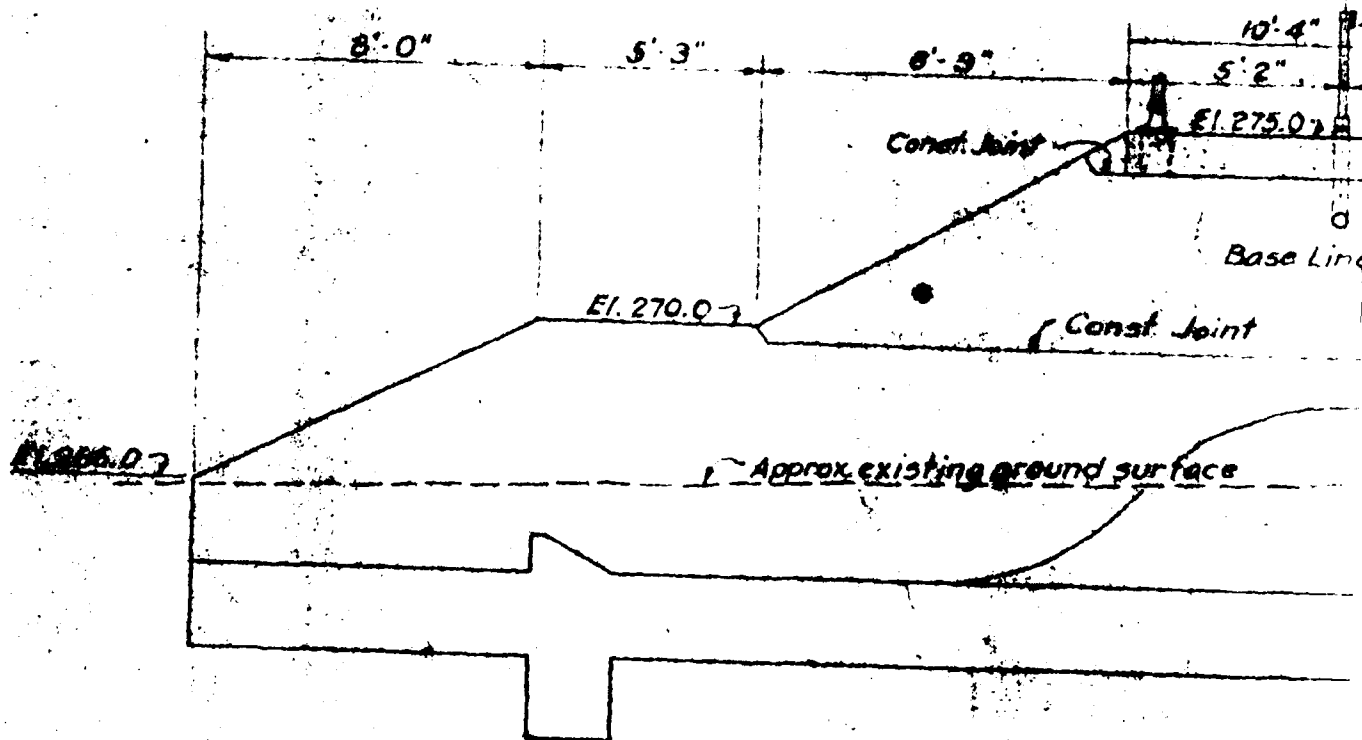

ELEVATION OF WEST A
LOOKING WEST
SCALE 1/2" = 1'-0"

5

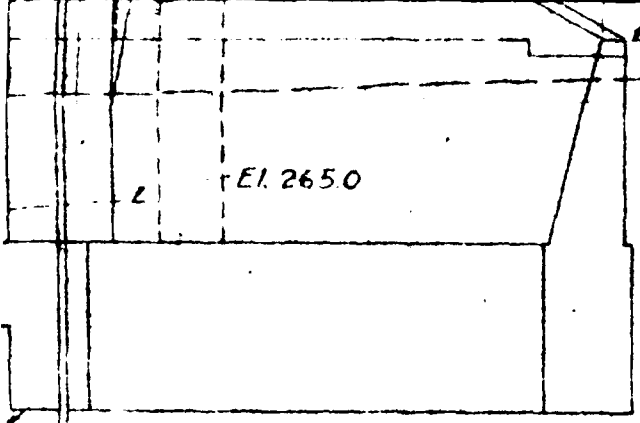

ABUTMENT

PLAN OF FLO

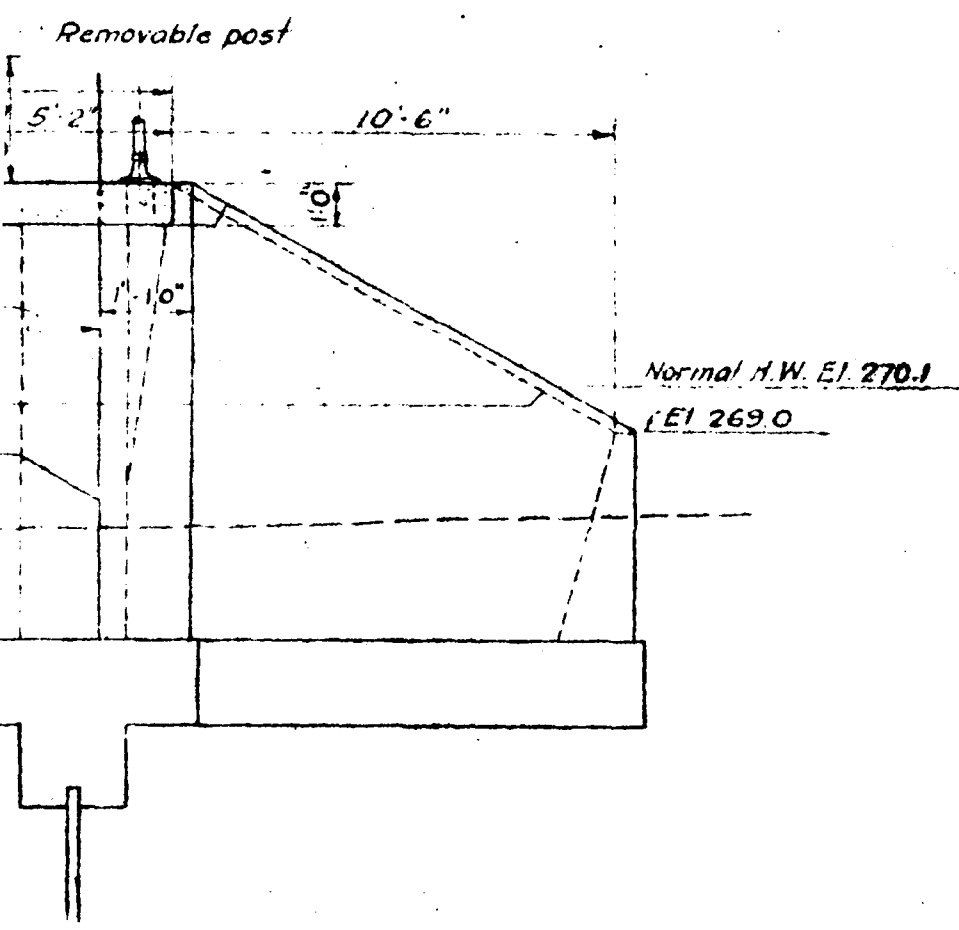

BUTMENT

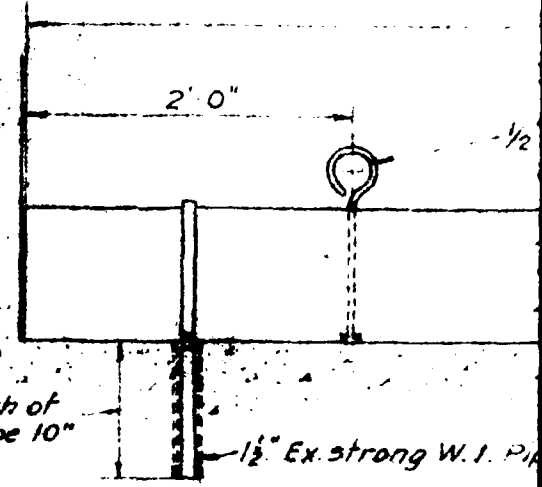

DETAIL

6

6' 6"

F →

flat, welded to short piece of 3/4" bolt, to fit into slot in angle as a locking device.

FLOOR PLATE ON BRIDGE

SECTION F-F

SCALE 1" = 1'-0"

9' 4" ±

2' 0"

1/2" φ eye bolt, galv.
2 1/2" φ eye

Max. clearance 1/8"

2" x 10" Plank

Flashboard pin 3/4" φ x 1' 8"
structural grade steel rod, section
1" wide at center to be turned
to a diameter of 0.71", or as
directed by the Engineer.
Galv. after turning.

V.I. Pipe, galv.

TAIL OF FLASHBOARD

SCALE 1" = 1'-0"

The approval of these Plans and Specifications by the County Commissioners is contingent on the Channel of the Charles River being widened through the congested section of Milford as part of a second P.W.A. Project sponsored by the Town of Milford.

The Gates of the present Cedar Meadow Pond Dam are to be removed at once for all time.

7

each side, a remaining

ON F-F

SECTION G-G

SCALE 3" = 1'-0"

P.W.A. PROJECT NO. MASS. 1446-F
CEDAR SWAMP DEVELOPEMENT
CONTRACT 1

section
of

WORCESTER COUNTY COMMISSIONERS
WORCESTER COUNTY ENGINEERING DEPARTMENT
PLAN OF
MISCELLANEOUS DETAILS, PART II
OF DAM
AT CEDAR SWAMP POND
MILFORD, MASS.
FOR TOWN OF MILFORD
AS FILED AND APPROVED BY THE
COUNTY COMMISSIONERS
SCALES AS NOTED

ions
the
ough
second
rd.
nd Dum

Approved: *Dec 6, 1938*
Elbert M. ...
Chairman, Board of County Commissioners
George W. Jones
County Commissioner
Thomas P. ...
County Commissioner

Submitted
for Approval: *Dec 6, 1938*
L. O. Marden
County Engineer
FAY, BROFFORD & THORNGATE
BOSTON, MASS. OCT. 1938
DAM NO. 29-...

CONTRACT DRAWING SHEET NO. 2

8

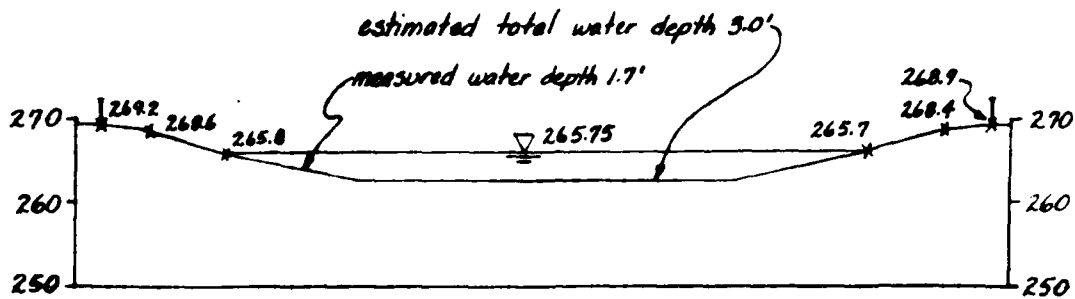

TYPICAL CHANNEL CROSS SECTION

1" = 20'

section measured at 270 ft downstream of dam

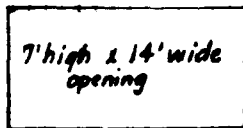

invert elev. 261.0

SECTION A-A
CULVERT OPENING

1" = 10'

- NOTES:
1. ELEVATIONS OF THE CHANNEL CROSS SECTION ARE BASED ON AN ASSUMED BENCHMARK ELEVATION OF 275 MSL OF THE DECK SURFACE FOR CEDAR SWAMP DAM.
 2. ELEVATIONS SHOWN IN SECTIONS A-A' AND B-B' ARE BASED ON AN ESTIMATED SURFACE ELEVATION OF 265.6 AT THE UPSTREAM EDGE OF THE APPROXIMATE SPILLWAY TAILWATER AND AT 270 FEET DOWNSTREAM.
 3. DOWNSTREAM BOX CULVERT LOCATED ABOUT 1200 FEET SOUTH FROM CEDAR SWAMP POND DAM.

Metcalf & Eddy

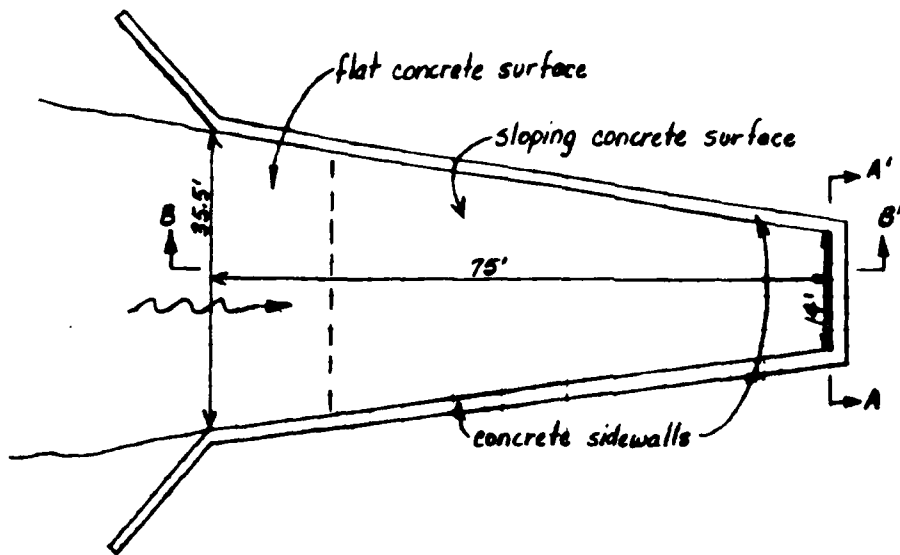

PLAN VIEW OF CULVERT & APPROACH CHANNEL

1" = 20'

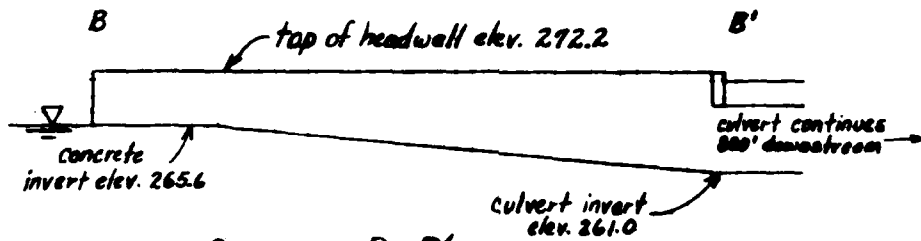

SECTION B-B'

APPROACH CHANNEL TO CULVERT

1" = 20'

BASED ON AN ASSUMED SURFACE FOR CEDAR SWAMP POND DAM. BASED ON AN ESTIMATED WATER OF THE APPROACH CHANNEL. THIS ELEVATIONS SURVEYED AT THE (STREAM). 0 FEET SOUTH FROM THE

BASED ON FIELD SURVEY OF JUNE 14, 1978

Figure B-4. DETAILS OF DOWNSTREAM CHANNEL AND CULVERT

TOWN OR CITY *Milford* DECREE NO.
 LOCATION *Cedar Swamp Pond*

PLAN NO.

DAM NO. *29-041*
 C. C. DOCKET NO. *115*

DESCRIPTION OF DAM

DESCRIPTION OF RESERVOIR & WATERSHED

Type *Earth Embankment*
 Length *100'*
 Height
 Thickness top *10' 4"*
 " bottom
 Downstream Slope *1:1 3/4*
 Upstream " *1:1 3/4*
 Length of Spillway *93.33*
 Size of Gates
 Location of Gates
 Flashboards used
 Width Flashboards or Gates
 Dam designed by
 " constructed by
 Year constructed

Name of Main Stream *Charles River*
 " " any other Streams
 Length of Watershed
 Width " "
 Is Watershed Cultivated
 Percent in Forests *80%*
 Steepness of Slope
 Kind of Soil
 No. of Acres in Watershed *792 sq M 93 sq mi*
 " " " " Reservoir *15 sq mi*
 Length of Reservoir
 Width " "
 Max Flow Cu. Ft. per Sec.
 Head of Flashboards-Low Water
 " " " " High "

GENERAL REMARKS

GENERAL REMARKS

Owned by: Town of Milford (Ray Spofford & Associates)
Inspected: Dec. 12, 1938 - L.O. Marden (E.M. Crockett)
Inspected: Dec. 21, 1938 - M. Finlayson
 " : Jan. 7, 1939 " "
 " : " 9 " - L.O. Marden.
 " : " 30 " "
 " : Aug. 7, " "

Inspected: June 13, 1951 - L.O.M. P.E. Carey & C. Varney
 " : Nov. 17, 1958 - L.O.M.
 " : July 21, 1961 - A. Fitzgerald.
 " : 1/11/72 - V.F.P. & R.W.

2-Library Bureau 18-92760

PREVIOUS INSPECTIONS (PARTIAL LISTING)

COPY OF INSPECTION CARD ON FILE AT THE MASSACHUSETTS
 DEPARTMENT OF PUBLIC WORKS, DISTRICT OFFICE, WORCESTER.

INSPECTION REPORT & DATA FOR DAMS

Owner: TOWN OF MILFORD
 His Address:
 Function of Dam: STORAGE

Dam No. 29-041
 Town: MILFORD
 Stream: CHARLES CREEK
 Pond: CEDAR SWAMP LND
 Date: 1/11/72
 By:
 CONDITION RATING
 Structural: GOOD
 Hydraulic: GOOD
 General: GOOD
 PRIORITY: LOW

Location & Access: LT ON MEADE ST FROM RTE 16
TO HAYWARD FLD ST-LT. TO DAM.

USGS Quad MILFORD Lat. 42-08-50 Long. 71-30-50
 Drain. Ar. 292 Sq. Mi. Ponds: RC.; Res. 6dam
 Character of D.A.: ---

Estimated
 Discharge:
 Capacity:

General Description of Dam and Discharge Control:

2- 4x4 GATES CLOSED. SPILLWAY HAS 5 SECTIONS OF 19' EACH
3x12" FLASHBOARDS ON ALL 5 SPILLWAYS

Sketch (Not to Scale):

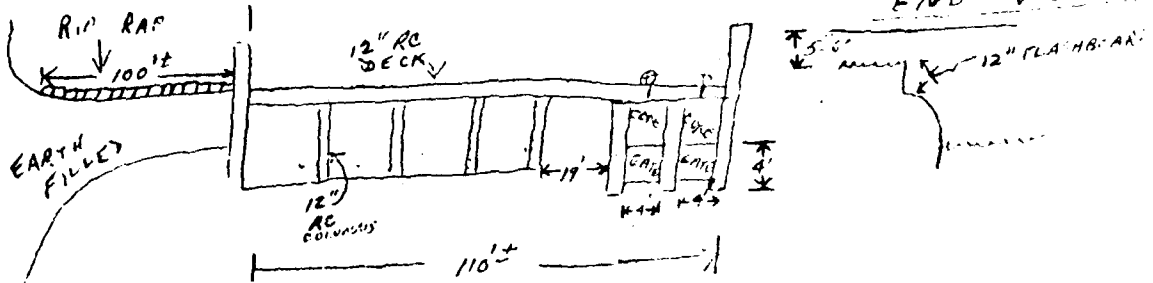

Remarks and Recommendations:

Date
1/11/72

By
J. E. P.
R. J.

Comment

Dam No. 3-14-185-041

FAY, SPOFFORD & THORNDIKE
 HYDRAULIC CALCULATIONS - CEDAR SWAMP POND

DATE: 5-13-39
 COMPUTED BY: R.L.F.

ELEVATION FT ABOVE M.S.L.	AREA ACRES	CAPACITY MILL. GALS.
270.1	153.8	132.8
269.6	151.4	107.5
269.1	147.7	83.5
268.6	136.4	62.6
268.1	97.1	43.6
267.6	82.0	28.6
267.1	61.7	17.8

WATERSHED AREA

TOTAL AREA = 9.30 ± SQ. MILES
 WOODED = 7.91 ± SQ. MILES
 RESIDENTIAL = 0.80
 PASTURE }
 CULTIVATED } = 0.14
 WATER SURFACE = 0.45
9.30

CLEAR LENGTH OF SPILLWAY = 93.33'; CREST ELEV. 270.1
 BOTTOM OF BRIDGE ELEV. 274
 TOP FLASHBOARD ELEV. 269.5

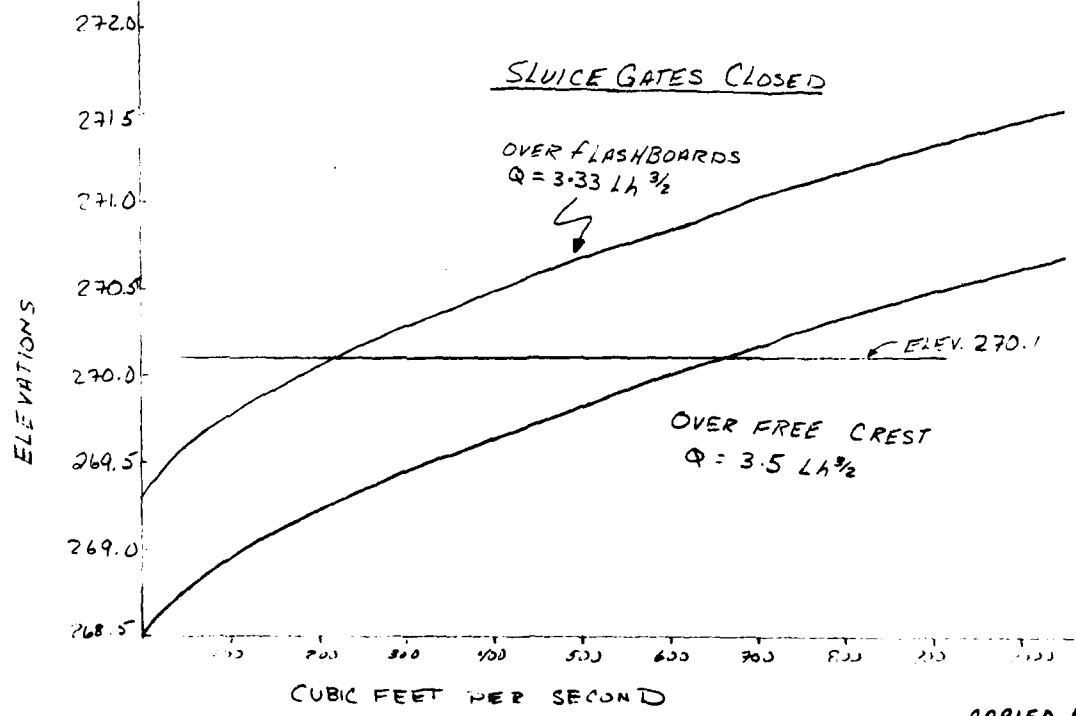

COPIED BY
 METCALF & EDDY, INC.
 JUNE 1978

APPENDIX C
PHOTOGRAPHS



NO. 1 - VIEW OF EAST ABUTMENT, UPSTREAM AREA



NO. 2 - DETAIL OF RIP RAP ON UPSTREAM FACE OF WEST ABUTMENT



**NO. 3 - DETAIL OF SPILLWAY WEIR SHOWING
FLASHBOARDS AND CONCRETE PIERS**



**NO. 4 - VIEW OF EAST ABUTMENT, DOWNSTREAM
FACE, WITH SLIDE GATES IN CENTER OF PICTURE**



NO. 5 - VIEW OF SLIDE GATES OPEN



**NO. 6 - OVERVIEW OF DOWNSTREAM CHANNEL
LOOKING FROM CENTER OF DAM**

11/1

APPENDIX D
HYDROLOGIC AND HYDRAULIC
COMPUTATIONS

Project Nat. Review of Non-F. Dams Acct. No. 5207 Page 1 of 4
 Subject Worcester, Ma. Area Comptd. By LEB Date 6/2/78
 Detail Cedar Swamp Pond Dam CK'd. By ELC Date 5/7/78
 Rev. 7/19/78 LEB

(I) Determine Peak Rate of Runoff

Est. Slope Elev 497 to Elev. 267 in 20000'

$$\text{Slope} = 1.1\%$$

Est. Ponds & Swamps

Ponds - 0.365 mi² - Say 0.40 mi² (incl sw. pond)
 Swamps (by eye) about same 0.40
 0.80 mi²

D.A. = 8.03 mi² - Say 10% Swamps & Ponds

Est. Peak Flow Rates

$$\frac{1.1 - 0.6}{3.0 - 0.6} = \frac{0.5}{2.4} = 21\% \text{ bet. Flat \& Coastal \& Leesville"}$$

$$\text{MPF - Peak Flow Rate} = 875 \text{ cfs/mi}^2$$

$$\text{PMP Flood Peak} = 875 \times 8.03 = 7026 \text{ cfs}$$

$$\frac{1}{2} \text{ PMP " " } = \boxed{3513 \text{ cfs Inflow Test Flood}}$$

100 year Flood

Std. 6 hr. 100 yr. storm contains 4.7 inches of rain

Ave. min infiltration taken @ 0.18 in./hr for total in 6 hr of 1.1 inches

$$Q_{100} = 7026 \left[\frac{4.7 - 1.1}{19 - 1.1} \right] = \underline{1413 \text{ cfs inflow}}$$

Storage Functions

$$\text{Test Flood: } Q_F = 3513 \left(1 - \frac{S_F}{9.5} \right) = 3513 - 3705 = F_{TF}$$

$$100 \text{ yr. Inf.: } Q_{F_{100}} = 1413 \left(1 - \frac{S_F}{4.7} \right) = 1413 - 3015 = F_{100}$$

II Flow over Spillway & Storage

$Q = CLH^{1.5}$; $h/H_e \approx 1$ @ high flows

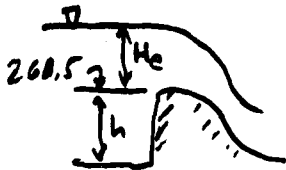

$\therefore C = 0.97(4.03) = 3.91$ [Ref. V.T.C. Spch Fl. pg 366]

Crest Length = 5 bays @ 18'8" = 93.35'

Contr. = $2 \times 0.035 \times 5' \times 5' = 1.75'$ (Round Nose Piers)

$\therefore L = 93.35 - 1.75 = 91.60'$

$Q = 3.91 (91.60) H_e^{1.5} = 358 H_e^{1.5}$ [H meas. above crest to Pond Level]

Storage as Incher on D.A. = $5 = 12 H_e \left(\frac{1.45}{8.03} \right) = 0.246 H_e$

H_e	0.6	1.6	2.6	3.6	4.6	5.6
Q	166	725	1501	2446	3533	4745
Elev.	269.1	270.1	271.1	272.1	273.1	274.1
S	.15	.39	.64	.89	1.13	1.38
F _{TF}				3184	3095	
F ₁₀₀		1295	1220	1145		

III Outflows - Taken from Disch. & Stor. Funct. Plots.

For Inflow Test Flood: $Q_{out} = 3110$ cfs @ El. 272.75

For 100 yr Freq Flood : $Q_{out} = 1230$ cfs @ El. 270.80.

Subject Worcester, Mass. Area Comptd By LEB Date 6/23/78
 Detail Cedar Swamp Dam Ckd By EMG Date 6/28/78

IV Free board

[From "Low Dams"]

$$\text{Wave Ht } (\approx \text{Free board}) = h = 1.5(D^{1/2}) + 2.5 - (D)^{1/4}$$

$$D = \text{Fetch in miles} = 4400' = 0.8333$$

$$h = 1.5(.913) + 2.5 - 0.96 = 2.91 \text{ - Say } \underline{3' \text{ Min Free board}}$$

V Hydraulics of "Main St" Culvert

Culvert is 14' wide x 7' high concrete box
 Approx. 800' long. Use $Q = 3323$ cfs.

A- Entrance Control (Ref. U.T.C. Open Chan Hydr. - pg 498)

$$Q/b = \frac{3323}{14} = 237.4 \text{ cfs/ft of width}$$

with $d = 7'$, $H/2 \approx 7$ (extrapolated from curves)

$$\therefore H = 7 \times 7 = 49', \text{ W.S. Elev. } \approx 261 + 49 = \underline{310'}$$

B - Pipe Control (Flow observed to be subcritical)

→ Assume $S = 0.01$ - Drop = 8', & Disch @ 261-8+3.5 = 256.5

$$\text{Let } H = \text{Ent. Elev.} - 256.5 = 0.5 h_v + h_v + 800 S_E$$

$$S_E = \left[\frac{V n}{1.49 R^{4/3}} \right]^2, V = \frac{3323}{98}, n = .015, R = \frac{98}{42}, R^{1/3} = 1.759$$

$$\therefore S_E = 0.0376; 800 S_E = 30.12', h_v = 17.85'$$

$$\therefore \text{Ent Elev} = 256.5 + 30.12 + 26.78 = \underline{313.4'}$$

C - Use "Pipe Control" det Q vs Ent Elev.

$$H = \text{Ent. Elev.} - 256.5 = V^2 \left[\frac{1.5}{2} + 800 \left[\frac{n}{1.49 R^{4/3}} \right]^2 \right] = V^2 [0.0233 + 0.0261]$$

$$\text{Ent. Elev.} = 256.5 + 5.14 \times 10^{-6} Q^2$$

Q	1000	2000	1200	1400	1600	1800	1900
Ent Elev	261.5	277.0	263.9	266.6	269.7	273.2	275.1

Project Nat. Review of Non Fed. Dams Acct. No. 5864 Page 4 of 4
 Subject Worcester, Mass. Area Comptd. By LEB Date 6/27/78
 Detail Cedar Swamp Pond. Ch'd By EME Date 6/29/78
 Rev. 7/19/78 LEB

METCALF & EDDY, ENGINEERS

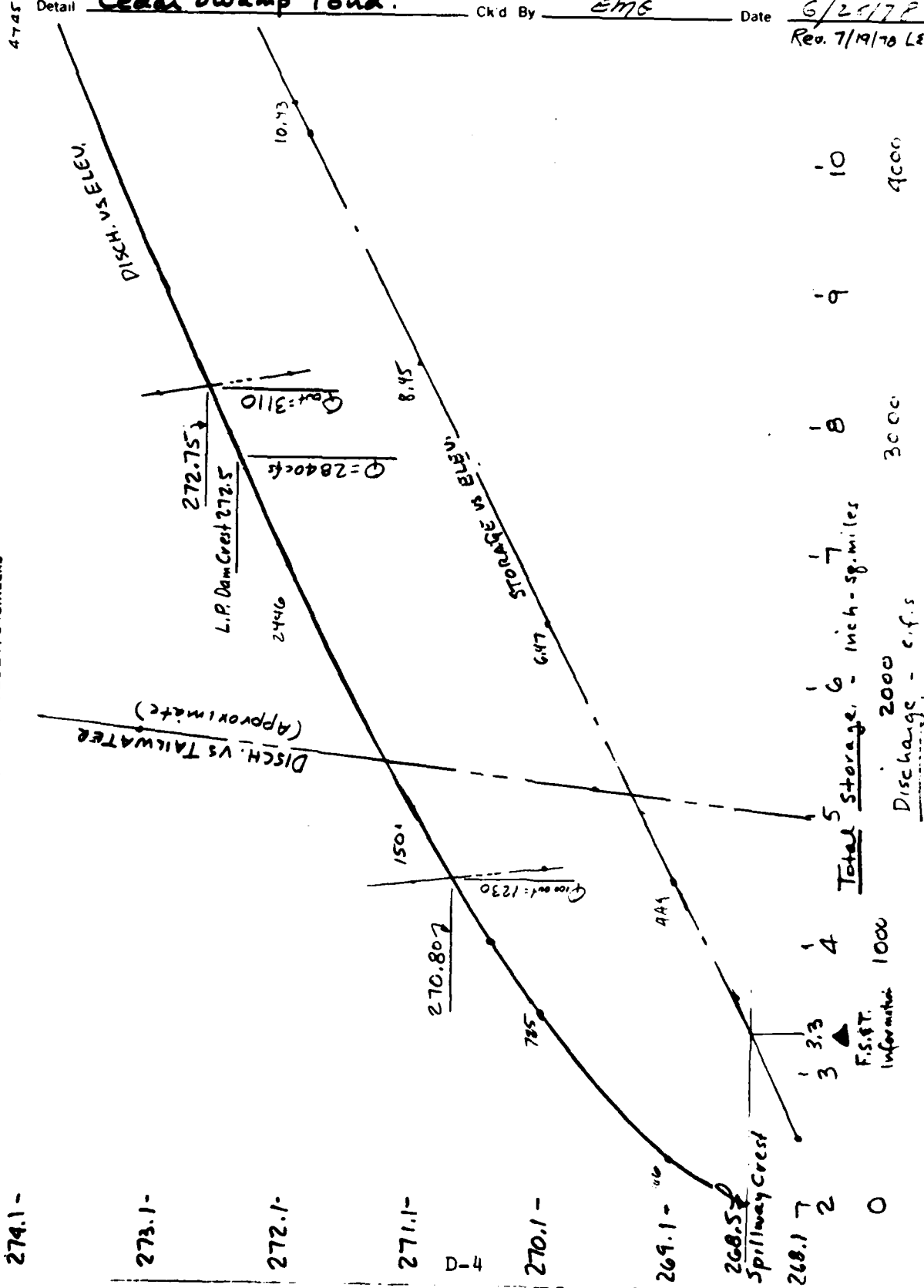

274.1-

273.1-

272.1-

271.1-

D-4

270.1-

269.1-

268.5

268.1

7

2

0

10

9

8

7

6

5

4

3

2

1

0

111

111

APPENDIX E
INFORMATION AS CONTAINED IN
THE NATIONAL INVENTORY OF DAMS



INVENTORY OF DAMS IN THE UNITED STATES

STATE	IDENTITY NUMBER	DIVISION	STATE	COUNTY	CORNER DET.	STATE	COUNTY	CORNER DET.	NAME	LATITUDE (NORTH)	LONGITUDE (WEST)	REPORT DATE DAY MO YR
MA	428	460	MA	027	03				CEDAR SWAMP POND DAM	4208.8	7130.8	20 JUL 76

POPULAR NAME	NAME OF IMPOUNDMENT
	CEDAR SWAMP POND

REGION	BASIN	RIVER OR STREAM	NEAREST DOWNSTREAM CITY-TOWN-VILLAGE	DIST FROM DAM (MI.)	POPULATION
01	06	CHARLES RIVER	MILFORD	0	23400

TYPE OF DAM	YEAR COMPLETED	PURPOSES	STRUCT. HEIGHT (FT.)	HYDRAU. HEIGHT (FT.)	IMPOUNDING CAPACITIES		DIST	OWN	FED	R	PRV	/PED	3CB	A	VER/DATE
					MAXIMUM (ACR.-FT.)	NORMAL (ACR.-FT.)									
HECTPG	1939	R	8	8	720	400	NED	N	N	N	N	N	N	N	20JUL76

REMARKS

D.S. HAS	SPILLWAY			MAXIMUM DISCHARGE (FT.)	VOLUME OF DAM (CV)	POWER CAPACITY		NAVIGATION LOCKS								
	CREST LENGTH	TYPE	WIDTH (FT.)			INSTALLED (MW)	PROPOSED (MW)	NO.	LENGTH (FT.)	WIDTH (FT.)	LENGTH (FT.)	WIDTH (FT.)	LENGTH (FT.)	WIDTH (FT.)		
2	314	U	93	2900	1000											

OWNER	ENGINEERING BY	CONSTRUCTION BY
TOWN OF MILFORD	FAY SPOFFORD + THORNDIKE	UNKNOWN

REGULATORY AGENCY			
DESIGN	CONSTRUCTION	OPERATION	MAINTENANCE
NONE	NONE	NONE	NONE

INSPECTION BY	INSPECTION DATE DAY MO YR	AUTHORITY FOR INSPECTION
METCALF + EDDY INC	14 JUN 76	PL 92-307

REMARKS

DATE
L MED
— 8