

MICROCOPY RESOLUTION TEST CHART
NATIONAL BUREAU OF STANDARDS-1963-A

AD-A155 596

1

MERRIMACK RIVER BASIN
WESTMINSTER, MASSACHUSETTS

WYMAN POND DAM

MA 00641

PHASE I INSPECTION REPORT
NATIONAL DAM INSPECTION PROGRAM



DEPARTMENT OF THE ARMY
NEW ENGLAND DIVISION, CORPS OF ENGINEERS
WALTHAM, MASSACHUSETTS 02154

DTIC
SELECTED
JUN 20 1975
G

DISTRIBUTION STATEMENT A
Approved for public release
Distribution Unlimited

AUGUST 1978

85 5 28 242

DTIC FILE COPY

UNCLASSIFIED

SECURITY CLASSIFICATION OF THIS PAGE (When Data Entered)

REPORT DOCUMENTATION PAGE		READ INSTRUCTIONS BEFORE COMPLETING FORM
1. REPORT NUMBER MA 00641	2. GOVT ACCESSION NO. A155596	3. RECIPIENT'S CATALOG NUMBER
4. TITLE (and Subtitle) Wyman Pond Dam NATIONAL PROGRAM FOR INSPECTION OF NON-FEDERAL DAMS	5. TYPE OF REPORT & PERIOD COVERED INSPECTION REPORT	6. PERFORMING ORG. REPORT NUMBER
7. AUTHOR(s) U.S. ARMY CORPS OF ENGINEERS NEW ENGLAND DIVISION	8. CONTRACT OR GRANT NUMBER(s)	
9. PERFORMING ORGANIZATION NAME AND ADDRESS	10. PROGRAM ELEMENT, PROJECT, TASK AREA & WORK UNIT NUMBERS	
11. CONTROLLING OFFICE NAME AND ADDRESS DEPT. OF THE ARMY, CORPS OF ENGINEERS NEW ENGLAND DIVISION, NEDED 424 TRAPELO ROAD, WALTHAM, MA. 02254	12. REPORT DATE August 1978	13. NUMBER OF PAGES 30
14. MONITORING AGENCY NAME & ADDRESS (if different from Controlling Office)	15. SECURITY CLASS. (of this report) UNCLASSIFIED	15a. DECLASSIFICATION/DOWNGRADING SCHEDULE
16. DISTRIBUTION STATEMENT (of this Report) APPROVAL FOR PUBLIC RELEASE: DISTRIBUTION UNLIMITED		
17. DISTRIBUTION STATEMENT (of the abstract entered in Block 20, if different from Report)		
18. SUPPLEMENTARY NOTES Cover program reads: Phase I Inspection Report, National Dam Inspection Program; however, the official title of the program is: National Program for Inspection of Non-Federal Dams; use cover date for date of report.		
19. KEY WORDS (Continue on reverse side if necessary and identify by block number) DAMS, INSPECTION, DAM SAFETY, Merrimack River Basin Westminster, Massachusetts Smith Brook		
20. ABSTRACT (Continue on reverse side if necessary and identify by block number) It is an earthfill structure with a concrete core. The dam is about 450 ft long and has a maximum height of about 16 ft. There are outlet works which are inoperable and are permanently closed. The dam appears to be in good condition and well maintained. It is intermediate in size with a significant hazard potential.		



DEPARTMENT OF THE ARMY
 NEW ENGLAND DIVISION, CORPS OF ENGINEERS
 424 TRAPELO ROAD
 WALTHAM, MASSACHUSETTS 02154



REPLY TO
 ATTENTION OF:

NEDED

Honorable Michael S. Dukakis
 Governor of the Commonwealth of
 Massachusetts
 State House
 Boston, Massachusetts 02133

NOV 28 1978

Accession For	
NTIS GRA&I	<input checked="" type="checkbox"/>
DTIC TAB	<input type="checkbox"/>
Unannounced	<input type="checkbox"/>
Justification	
By _____	
Distribution/	
Availability Codes	
Dist	Avail and/or Special
A/1	

Dear Governor Dukakis:

I am forwarding to you a copy of the Wyman Pond Dam Phase I Inspection Report, which was prepared under the National Program for Inspection of Non-Federal Dams. This report is presented for your use and is based upon a visual inspection, a review of the past performance and a brief hydrological study of the dam. A brief assessment is included at the beginning of the report. I have approved the report and support the findings and recommendations described in Section 7 and ask that you keep me informed of the actions taken to implement them. This follow-up action is a vitally important part of this program.

A copy of this report has been forwarded to the Department of Environmental Quality Engineering, the cooperating agency for the Commonwealth of Massachusetts. In addition, a copy of the report has also been furnished the owner, the City of Fitchburg, 718 Main Street., Fitchburg, Massachusetts 01420, ATTN: Mr. Joseph Levanti, Commissioner of Public Works.

Copies of this report will be made available to the public, upon request, by this office under the Freedom of Information Act. In the case of this report the release date will be thirty days from the date of this letter.

I wish to take this opportunity to thank you and the Department of Environmental Quality Engineering for your cooperation in carrying out this program.

Sincerely yours,

John P. Chandler
 JOHN P. CHANDLER
 Colonel, Corps of Engineers
 Division Engineer

Incl
 As stated

WYMAN POND DAM

MA 00641

MERRIMACK RIVER BASIN
WESTMINSTER, MASSACHUSETTS

PHASE I INSPECTION REPORT
NATIONAL DAM INSPECTION PROGRAM

NATIONAL DAM INSPECTION PROGRAM

PHASE I INSPECTION REPORT

Identification No.: MA 00641
Name of Dam: Wyman Pond Dam
Town: Westminster, Massachusetts
County and State: Worcester County, Massachusetts
Stream: Smith Brook
Date of Inspection: June 14, 1978

BRIEF ASSESSMENT

The Wyman Pond Dam, constructed almost 80 years ago, is an earthfill structure with a concrete core. The dam is about 450 feet long and has a maximum height above stream bed of about 16 feet.

The dam has a 50-foot long ungated spillway with 5 feet of freeboard, the downstream channel of which leads to a culvert under a highway intersection just downstream of the dam. There are outlet works which are inoperable and are permanently closed. The reservoir is used for recreation purposes with several dwellings close to its periphery and in the watercourse downstream of the dam.

The dam appears to be in good condition and well maintained. The only drawing available shows its dimensions to be compatible with modern design concepts.

Owing to its impoundment volume, the Wyman Pond Dam falls within the intermediate size classification. It is in the significant hazard potential category and thus hydraulically analyzed using the full probable maximum flood.

Reservoir storage will reduce the probable maximum discharge of 13,250 cfs to a test flood of 10,600 cfs. The spillway structure, itself, can discharge about 1,700 cfs (15 percent of the test flood). However, a culvert under the highway downstream of the dam can discharge only 500 cfs (4 percent of the test flood) before the highway is overtopped.

In the event of the test flood (using 13,250 in calculations due to culvert capacity), the highway would be overtopped by about 3 feet; the dam by about 5½ feet. Water level differences would be in the order of 4 feet, thus a failure of the dam during the test flood would not add significantly to the total discharge. The Peak Failure Outflow of 15,150 cfs is comparable to the test flood. Either would cause some flooding and possible damage to houses in the watercourse downstream, but hazard to human life would be minimal.

Additional investigations or major modifications are not required. The owner should, however, institute regular inspection and maintenance procedures, clear the spillway channel of growth and debris, and make necessary repairs to the channel structure, reactivate the outlet works and develop a flood warning system. These measures should be implemented by the owner within 24 months of the receipt of this Phase I Inspection Report.

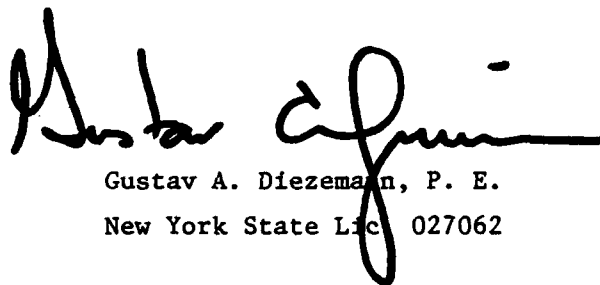

Gustav A. Diezeman, P. E.
New York State Lic 027062

This Phase I Inspection Report on Wyman Pond Dam has been reviewed by the undersigned Review Board members. In our opinion, the reported findings, conclusions, and recommendations are consistent with the Recommended Guidelines for Safety Inspection of Dams, and with good engineering judgment and practice, and is hereby submitted for approval.



CHARLES G. TIERSCH, Chairman
Chief, Foundation and Materials Branch
Engineering Division



FRED J. RAVENS, Jr., Member
Chief, Design Branch
Engineering Division



SAUL COOPER, Member
Chief, Water Control Branch
Engineering Division

APPROVAL RECOMMENDED:

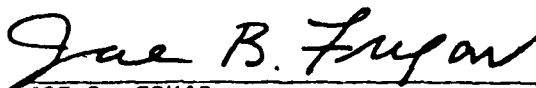

JOE B. FRYAR
Chief, Engineering Division

PREFACE

This report is prepared under guidance contained in the Recommended Guidelines for Safety Inspection of Dams, for Phase I Investigations. Copies of these guidelines may be obtained from the Office of Chief of Engineers, Washington, D.C. 20314. The purpose of a Phase I Investigation is to identify expeditiously those dams which may pose hazards to human life or property. The assessment of the general condition of the dam is based upon available data and visual inspections. Detailed investigation and analyses involving topographic mapping, subsurface investigations, testing, and detailed computational evaluations are beyond the scope of a Phase I investigation; however, the investigation is intended to identify any need for such studies.

In reviewing this report, it should be realized that the reported condition of the dam is based on observations of field conditions at the time of inspection, along with data available to the inspection team. In cases where the reservoir was lowered or drained prior to inspection, such action, while improving the stability and safety of the dam, removes the normal load on the structure and may obscure certain conditions which might otherwise be detectable if inspected under the normal operating environment of the structure.

It is important to note that the condition of a dam depends on numerous and constantly changing internal and external conditions, and is evolutionary in nature. It would be incorrect to assume that the present condition of the dam will continue to represent the condition of the dam at some point in the future. Only through continued care and inspection can there be any chance that unsafe conditions be detected.

Phase I inspections are not intended to provide detailed hydrologic and hydraulic analyses. In accordance with the established Guidelines, the Spillway Test flood is based on the estimated "Probable Maximum Flood" for the region (greatest reasonably possible storm runoff), or fractions thereof. Because of the magnitude and rarity of such a storm event, a finding that a spillway will not pass the test flood should not be interpreted as necessarily posing a highly inadequate condition. The test flood provides a measure of relative spillway capacity and serves as an aid in determining the need for more detailed hydrologic and hydraulic studies, considering the size of the dam, its general condition and the downstream damage potential.

TABLE OF CONTENTS

BRIEF ASSESSMENT	1
REVIEW BOARD SIGNATURE SHEET	iii
PREFACE	iv
TABLE OF CONTENTS	v
OVERVIEW PHOTO	vi
LOCATION MAP	vii
REPORT	
SECTION 1 - PROJECT INFORMATION	1
SECTION 2 - ENGINEERING DATA	5
SECTION 3 - VISUAL INSPECTION	6
SECTION 4 - OPERATING PROCEDURES	8
SECTION 5 - HYDRAULIC/HYDROLOGIC	9
SECTION 6 - STRUCTURAL STABILITY	10
SECTION 7 - ASSESSMENT, RECOMMENDATIONS AND REMEDIAL MEASURES	11
APPENDIX A - VISUAL INSPECTION CHECKLIST	
APPENDIX B - EXISTING RECORDS	
APPENDIX C - PHOTOGRAPHS	
APPENDIX D - HYDRAULIC COMPUTATIONS	
APPENDIX E - INFORMATION AS CONTAINED IN THE NATIONAL INVENTORY OF DAMS	



OVERVIEW PHOTO

PHASE I INSPECTION REPORT

WYMAN POND DAM

SECTION I

PROJECT INFORMATION

1.1 General

a. Authority. Public Law 92-367, August 8, 1972, authorized the Secretary of the Army, through the Corps of Engineers, to initiate a National Program of Dam Inspection throughout the United States. The New England Division of the Corps of Engineers has been assigned the responsibility of supervising the inspection of dams within the New England Region. Chas. T. Main, Inc. has been retained by the New England Division to inspect and report on selected dams in the State of Massachusetts. Authorization and notice to proceed were issued to Chas. T. Main, Inc. under a letter of May 3, 1978, from Ralph T. Garver, Colonel, Corps of Engineers. Contract No. DACW33-78-D328 has been assigned by the Corps of Engineers for this work.

b. Purpose.

(1) Perform technical inspection and evaluation of non-Federal dams to identify conditions which threaten the public safety and thus permit correction in a timely manner by non-Federal interests.

(2) Encourage and prepare the states to initiate quickly effective dam safety programs for non-Federal dams.

(3) To update, verify and complete the National Inventory of Dams.

1.2 Description of Project

a. Location. The Wyman Pond Dam on Smith Brook, a tributary of the North Nashua River, is located in the Town of Westminister, Worcester County, Massachusetts.

b. Description of Dam and Appurtenances. The dam is an almost 80-year old fill structure with a concrete core. It is approximately 450 feet long and has a maximum height of about 16 feet above original stream bed. There is a 50-foot wide by 5-foot high granite block spillway section which discharges into a curved, rocky channel leading to a culvert under the highway just downstream of the dam.

There is a granite block gatehouse which originally controlled a 30-inch conduit carrying water from Wachusett Lake to the City's chlorination plant, and two 36-inch outlet conduits which discharge into the stream below the dam. The gates are all inoperable, the former being permanently open and the latter two permanently closed.

c. Size Classification. Owing to its impoundment volume of approximately 2,600 acre feet below the spillway crest, the dam falls within the intermediate size classification.

d. Hazard Classification. As there are some dwellings along the banks of the watercourse below the dam, the dam is considered to have significant hazard potential.

e. Ownership. The dam is owned by the City of Fitchburg, Mass.

f. Operator. Mr. J. Andre Provencial, City Hall - 718 Main Street, Fitchburg, Massachusetts. Telephone (617) 342-4212.

g. Purpose of Dam. The dam was apparently constructed by the City of Fitchburg as compensation for the City's use of Wachusett Lake for water supply. Wyman Pond is used for recreation.

h. Design and Construction History. Other than a sketch in the files of the City of Fitchburg, reproduced herein in Appendix B, nothing is known of the design history of this project. It was constructed in 1900.

i. Normal Operating Procedures. There are no operating procedures other than letting the spillway overflow as required by the natural inflow.

1.3 Pertinent Data

a. Drainage Area. The reservoir has a drainage area of approximately 4900 acres of essentially wooded, rolling hills, with some flat, swampy areas.

b. Discharge at Damsite.

(1) The outlet works consist of two permanently closed conduits. The gatehouse is kept maintained and locked.

(2) The maximum flood at the damsite is unknown.

(3) The ungated spillway capacity at maximum pool level, El. 892 ±, is 1,700 cfs.

(4) There is no gated spillway capacity.

(5) There is no gated spillway capacity.

(6) The total spillway capacity at maximum pool elevation is 1,700 cfs.

c. Elevation (Feet Above MSL)

(1)	Top of dam	El. 892 ±
(2)	Maximum design surcharge	El. 892 ±
(3)	Full flood control pool	N/A
(4)	Recreation pool	El. 887 ±
(5)	Spillway crest (gated)	El. 887 ± (ungated)
(6)	Upstream portal invert diversion tunnel	N/A
(7)	Streambed at centerline of dam	El. 876 ±
(8)	Maximum tailwater	El. 893 ±

d. Reservoir (Feet)

(1)	Length of maximum pool	12,000 ±
(2)	Length of recreation pool	12,000 ±
(3)	Length of flood control pool	N/A

e. Storage (Acre-Feet)

(1)	Recreation pool	2,400
(2)	Flood control pool	N/A
(3)	Design surcharge	4,000
(4)	Top of dam	4,000

f. Reservoir Surface (Acres)

(1)	Top of dam	573 ±
(2)	Maximum pool	573 ±
(3)	Flood control pool	N/A
(4)	Recreation pool	326 ±
(5)	Spillway crest	326 ±

g. Dam

(1)	Type	Earthfill with concrete core
(2)	Length	500 ± feet
(3)	Height	16 feet
(4)	Top Width	20 feet
(5)	Side slope -	2H: 1V (both slopes)
(6)	Zoning	Unknown
(7)	Impervious core	Unknown
(8)	Cutoff	Concrete to rock
(9)	Grout curtain	Unknown
(10)	Other	N/A

h. Spillway

(1)	Type	Flat weir
(2)	Length of weir	50 feet
(3)	Crest elevation	El. 887 ±
(4)	Gates	None
(5)	U/S Channel	N/A
(6)	D/S Channel	Rocky channel
(7)	General	N/A

i. Regulating Outlets. The regulating outlets are inoperable.

SECTION 2
ENGINEERING DATA

2.1 Design

The only data known to exist is a drawing furnished by the City of Fitchburg, showing a cross-section of the dam and its general dimensions.

2.2 Construction

The dam was constructed about 1900. Other than this, no construction data are known to exist.

2.3 Operation

Operational data are not kept.

2.4 Evaluation

a. Availability. There are no engineering data available other than the drawing mentioned in Par. 2.1 above.

b. Adequacy. The lack of in-depth engineering data does not allow for a definitive review. Therefore, the adequacy of this dam, structurally and hydraulically, cannot be assessed from the standpoint of review of design calculations, but must be based primarily on the visual inspection, past performance history, and sound hydrologic and hydraulic engineering judgment.

c. Validity. Although visual inspection indicates the actual dam cross-section to be similar to that shown on the available drawing, the limited data available does not furnish a proper basis for a detailed evaluation of this dam.

SECTION 3

VISUAL INSPECTION

3.1 Findings

a. General. The Phase I visual inspection of the Wyman Pond Dam took place on June 14, 1978. The Wyman Pond Dam is a relatively low structure which blends easily into the abutting countryside. There are no apparent signs of vandalism. It is impossible to determine exactly where the dam ends and the natural abutments begin.

b. Dam. The almost 80-year old Wyman Pond Dam appears to be in good condition. No significant vertical or horizontal misalignments were observed, nor were wet spots on the downstream surface. The dam is generally covered by low vegetation.

c. Appurtenant Structures. The granite block spillway structure and its extension leading to the culvert under the highway is in fair condition structurally, although there is growth in some joints and in the channel. The locked granite block gatehouse structure appeared to be well maintained.

d. Reservoir Area. The banks are flat and wooded. There is no possibility of landslides or other sudden increase of sediment load in the reservoir. There are several houses, both permanent and seasonal, close to the water's edge. The public apparently uses the dam and its abutments for recreational purposes.

e. Downstream Channel. There is a highway just downstream of the dam. The channel downstream of the highway, over or under which any flood or failure flow would pass, is a narrow, steeply sloped natural watercourse. It is heavily wooded with several dwellings along its banks at varying heights above the stream bed. This watercourse is just over a mile long and discharges into a marsh.

3.2 Evaluation

The visual inspection indicated that the dam and gatehouse structure are in good condition and satisfactorily maintained. The spillway structure is in fair condition. The reservoir itself is not a factor in evaluating the dam. The watercourse below the dam is inhabited to the extent that property and life could be in jeopardy if the dam failed.

SECTION 4
OPERATIONAL PROCEDURES

4.1 Procedures

Beyond letting the reservoir discharge over the spillway, no operating procedures can be ascertained.

4.2 Maintenance of the Dam

The dam is well maintained by the City of Fitchburg. There are apparently no formal procedures.

4.3 Maintenance of Operating Facilities

The operating facilities are closed. However, the gatehouse is maintained by the City of Fitchburg.

4.4 Warning System

There is no warning system.

4.5 Evaluation

While maintenance appears to be good, operational procedures are, at best, minimal. Recommendations for improving this are given in Section 7.3.

SECTION 5

HYDRAULIC/HYDROLOGIC

5.1 Evaluation of Features

a. Design Data. The hydraulic/hydrologic analysis was made in accordance with "Preliminary Guidance for Estimating Maximum Probable Discharges in Phase I Dam Safety Investigations", "Estimating Effect of Surge Storage on Maximum Probable Discharges", and "Rule of Thumb Guidance for Estimating Downstream Dam Failure Hydrographs" as furnished by the New England Division, Corps of Engineers and "Recommended Guidelines for Safety Inspection of Dams" as issued by the Department of the Army, Office of the Chief of Engineers.

U.S.G.S. Quadrangle maps were used to determine reservoir and drainage areas. Where practicable, spillway dimensions were obtained by direct measurement. Hydraulic coefficients were assigned on the basis of experience and engineering judgment.

b. Experience Data. No specific experience data with respect to the hydraulic/hydrological characteristics of the project are known to exist.

c. Visual Observations. There is a highway intersection just downstream of the dam. The culvert under the highway cannot, obviously, pass high flows. The channel contains considerable growth and debris which would affect small flows.

d. Overtopping Potential. A Probable Maximum Flood of 13,250 cfs was determined. Owing to the significant hazard potential and intermediate size classification, the PMF was used in the determination of the Peak Outflow (or test flood) of 11,000 cfs. The spillway, at maximum pool elevation, can discharge about 1,700 cfs. This is theoretical only as the culvert under the highway downstream can pass only about 500 cfs before the highway is overtopped, thus producing considerable backwater at the dam during major flood periods.

Assuming a breach of 125 feet in the dam results in a Peak Failure Outflow of about 13,500 cfs. The discharge of this flow, too, would be inhibited by the culvert under the highway and would result in an overtopping of the highway.

Thus, whether there is a failure of the dam, or flows in excess of 500 cfs, the highway will be overtopped. The highway is not level and an accurate hydraulic analysis is not possible. With some rational and simplified assumptions, however, approximations can be made. The test flood of 11,000 cfs would overtop the dam by about 5 feet

and the highway by about 3 feet. The difference in water levels would be in the order of four feet; thus the failure of the dam during the test flood would not contribute significantly to the total discharge.

The water overtopping the highway would flow into the natural watercourse which parallels and goes under Narrows Road. There are no dwellings or other structures in the vicinity of the intersection which would be affected. There are several dwellings further down the watercourse which would probably be subjected to flooding and possible damage. There does not appear to be much potential hazard to human life.

The areas of impact immediately downstream of the dam are shown on the location map.

SECTION 6
STRUCTURAL STABILITY

6.1 Evaluation of Structural Stability

a. Visual Observations. Nothing was noted which would indicate that the dam is unstable.

b. Design and Construction Data. No design or construction data are known to exist other than the one drawing noted.

c. Operating Records. Not applicable.

d. Post Construction Changes. No data concerning any post construction changes are known to exist.

e. Seismic Stability. The dam is located in Seismic Zone No. 2 and in accordance with recommended Phase I guidelines does not warrant seismic analysis.

SECTION 7

ASSESSMENT, RECOMMENDATIONS AND REMEDIAL MEASURES

7.1 Dam Assessment

a. Condition. The Wyman Pond Dam is in good condition.

b. Adequacy of Information. The lack of in-depth engineering data did not allow for a definitive review. Therefore, the adequacy of this dam could not be assessed from the standpoint of reviewing design and construction data, but is based primarily on visual inspection, past performance history and engineering judgment.

c. Urgency. The required repair and maintenance work described in Section 7.3.b should be accomplished within two years of the receipt of this report by the owner.

d. Need for Additional Investigation. There is no need for additional investigation.

7.2 Recommendations

Additional engineering investigations or major modifications to the dam are not required.

7.3 Remedial Measures

a. Alternatives. Not applicable.

b. Operating and Maintenance Procedures. The owner of the dam should develop and implement procedures which would include:

(1) Bi-annual inspection of the dam and the initiation of repairs, as required.

(2) The spillway channel should be cleared of growth and debris.

(3) The stonework should be repaired as required.

(4) The outlet works should be reactivated so that the reservoir can be drained without breaching the dam or its abutments.

(5) Around the clock surveillance should be provided by the owner during periods of unusually heavy precipitation.

(6) The owner should develop a formal warning system with local officials for alerting downstream residents in case of emergency.

APPENDIX A

VISUAL INSPECTION CHECK LIST
PARTY ORGANIZATION

PROJECT Wymun Pond

DATE 6/14/78

TIME 11:00 AM

WEATHER CLEAR & WINDY

W.S. ELEV. 227 U.S. DN.S

PARTY:

1. J. Liccaich
2. D. Fischer
3. L. Cross
4. _____
5. _____

	PROJECT FEATURE	INSPECTED BY	REMARKS
1.	_____	_____	_____
2.	_____	_____	_____
3.	_____	_____	_____
4.	_____	_____	_____
5.	_____	_____	_____
6.	_____	_____	_____
7.	_____	_____	_____
8.	_____	_____	_____
9.	_____	_____	_____
10.	_____	_____	_____

INSPECTION CHECK LIST

PROJECT WYMAN POND

DATE 6/14/78

PROJECT FEATURE _____

NAME _____

AREA EVALUATED	CONDITION
<u>DIKE EMBANKMENT</u>	892.5±
Crest Elevation	897
Current Pool Elevation	none
Surface Cracks	none
Pavement Condition	none
Movement of Settlement of Crest	none
Lateral Movement	none
Vertical Alignment	none O.K.
Horizontal Alignment	O.K.
Condition at Abutment and at Concrete Structures	O.K.
Indications of Movement of Structural Items on Slopes	none
Trespassing on Slopes	none
Sloughing or Erosion of Slopes or Abutments	none
Rock Slope Protection - Riprap Failures	none
Unusual Movement or Cracking at or near Toes	none
Unusual Embankment or Downstream Seepage	none
Piping or Boils	none
Foundation Drainage Features	-
Toe Drains	-
Instruments on System	

INSPECTION CHECK LIST

PROJECT WYMAN POND

DATE 6/14/78

PROJECT FEATURE _____

NAME _____

AREA EVALUATED	CONDITION
<p><u>CONCRETE DAM</u></p> <p>Concrete Surfaces</p> <p>Structural Cracking</p> <p>Movement -- Horizontal & Vertical Alignment</p> <p>Junctions</p> <p>Drains -- Foundation, Joint, Face</p> <p>Water Passages</p> <p>Seepage or Leakage</p> <p>Monolith Joints -- Construction Joints</p> <p>Foundation</p>	<p style="text-align: center;"><i>NOT APPLICABLE</i></p> <p style="text-align: right;">3</p>

INSPECTION CHECK LIST

PROJECT WYMAN POND

DATE 6/14/78

PROJECT FEATURE _____

NAME _____

AREA EVALUATED	CONDITION
<p><u>OUTLET WORKS - INTAKE CHANNEL AND INTAKE STRUCTURE</u></p> <p>a. Approach Channel</p> <p> Slope Conditions</p> <p> Bottom Conditions</p> <p> Rock Slides or Falls</p> <p> Log Boom</p> <p> Debris</p> <p> Condition of Concrete Lining</p> <p> Drains or Weep Holes</p> <p>b. Intake Structure</p> <p> Condition of Concrete</p> <p> Stop Logs and Slots</p>	<p>NONE</p> <p>NONE</p> <p>NONE</p> <p>GATE HOUSE</p> <p>FAIR</p> <p>NONE</p>

INSPECTION CHECK LIST

PROJECT WYMAN POND

DATE 6/14/78

PROJECT FEATURE _____

NAME _____

AREA EVALUATED	CONDITION
<p><u>OUTLET WORKS - TRANSITION AND CONDUIT</u></p> <p>General Condition of Concrete</p> <p>Rust or Staining on Concrete</p> <p>Spalling</p> <p>Erosion or Cavitation</p> <p>Cracking</p> <p>Alignment of Monoliths</p> <p>Alignment of Joints</p> <p>Numbering of Monoliths</p>	<p><i>NOT APPLICABLE</i></p> <p>5</p>

INSPECTION CHECK LIST

PROJECT WYMAN POND

DATE 6/14/78

PROJECT FEATURE _____

NAME _____

AREA EVALUATED	CONDITION
<u>OUTLET WORKS - SPILLWAY WEIR, APPROACH AND DISCHARGE CHANNELS</u>	
a. Approach Channel General Condition Loose Rock Overhanging Channel Trees Overhanging Channel Floor of Approach Channel	 <i>clear</i> <i>none</i> <i>none</i> <i>clear</i>
b. Weir and Training Walls General Condition of Concrete ^{Granite Block} Rust or Staining Spalling Any Visible Reinforcing Any Seepage or Efflorescence Drain Holes	 <i>good</i> <i>none</i> <i>some</i> <i>none</i> <i>none</i> <i>none</i>
c. Discharge Channel General Condition Loose Rock Overhanging Channel Trees Overhanging Channel Floor of Channel Other Obstructions	 <i>none</i> <i>some</i> <i>obstructed by vegetation</i>

INSPECTION CHECK LIST

PROJECT WYMAN POND

DATE 6/14/78

PROJECT FEATURE _____

NAME _____

AREA EVALUATED	CONDITION
<p><u>OUTLET WORKS - CONTROL TOWER</u></p>	
<p>a. Concrete and Structural</p>	
<p> General Condition</p>	
<p> Condition of Joints</p>	
<p> Spalling</p>	
<p> Visible Reinforcing</p>	
<p> Rusting or Staining of Concrete</p>	
<p> Any Seepage or Efflorescence</p>	
<p> Joint Alignment</p>	
<p> Unusual Seepage or Leaks in Gate Chamber</p>	
<p> Cracks</p>	
<p> Rusting or Corrosion of Steel</p>	
<p>b. Mechanical and Electrical</p>	
<p> Air Vents</p>	
<p> Float Wells</p>	
<p> Crane Hoist</p>	
<p> Elevator</p>	
<p> Hydraulic System</p>	
<p> Service Gates</p>	
<p> Emergency Gates</p>	
<p> Lightning Protection System</p>	
<p> Emergency Power System</p>	
<p> Wiring and Lighting System</p>	

NOT
APPLICABLE

INSPECTION CHECK LIST

PROJECT WYMAN POND

DATE 6/14/78

PROJECT FEATURE _____

NAME _____

AREA EVALUATED	CONDITION
<p><u>OUTLET WORKS - OUTLET STRUCTURE AND OUTLET CHANNEL</u></p> <p>General Condition of Concrete</p> <p>Rust or Staining</p> <p>Spalling</p> <p>Erosion or Cavitation</p> <p>Visible Reinforcing</p> <p>Any Seepage or Efflorescence</p> <p>Condition at Joints</p> <p>Drain holes</p> <p>Channel</p> <p>Loose Rock or Trees Overhanging Channel</p> <p>Condition of Discharge Channel</p>	<p style="text-align: center;"><i>NOT APPLICABLE</i></p> <p style="text-align: right;">8</p>

INSPECTION CHECK LIST

PROJECT WYMAN POND

DATE 6/14/78

PROJECT FEATURE _____

NAME _____

AREA EVALUATED	CONDITION
<p><u>OUTLET WORKS - SERVICE BRIDGE</u></p> <p>a. Super Structure</p> <ul style="list-style-type: none"> Bearings Anchor Bolts Bridge Seat Longitudinal Members Under Side of Deck Secondary Bracing Deck Drainage System Railings Expansion Joints Paint <p>b. Abutment & Piers</p> <ul style="list-style-type: none"> General Condition of Concrete Alignment of Abutment Approach to Bridge Condition of Seat & Backwall 	<p style="text-align: center;"><i>NOT APPLICABLE</i></p> <p style="text-align: right;">9</p>

APPENDIX B

Only a few drawings were available.

Excerpts from these drawings follow.

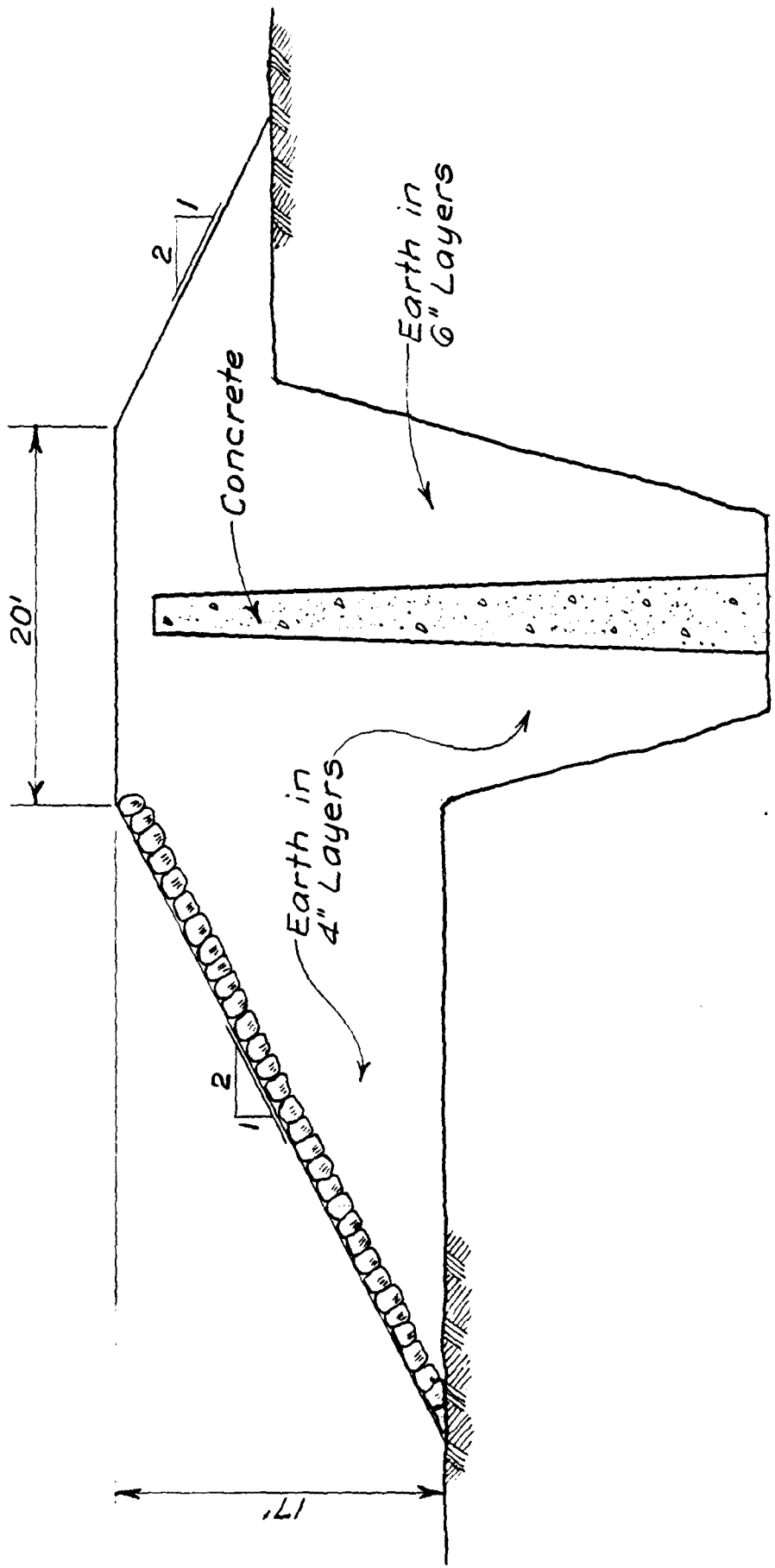

SECTION THRU EMBANKMENT

Scale: $\frac{1}{8}'' = 1'-0''$

WYMAN POND DAM

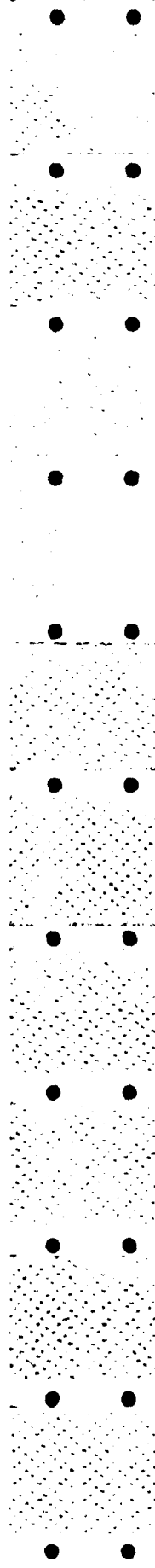

APPENDIX C

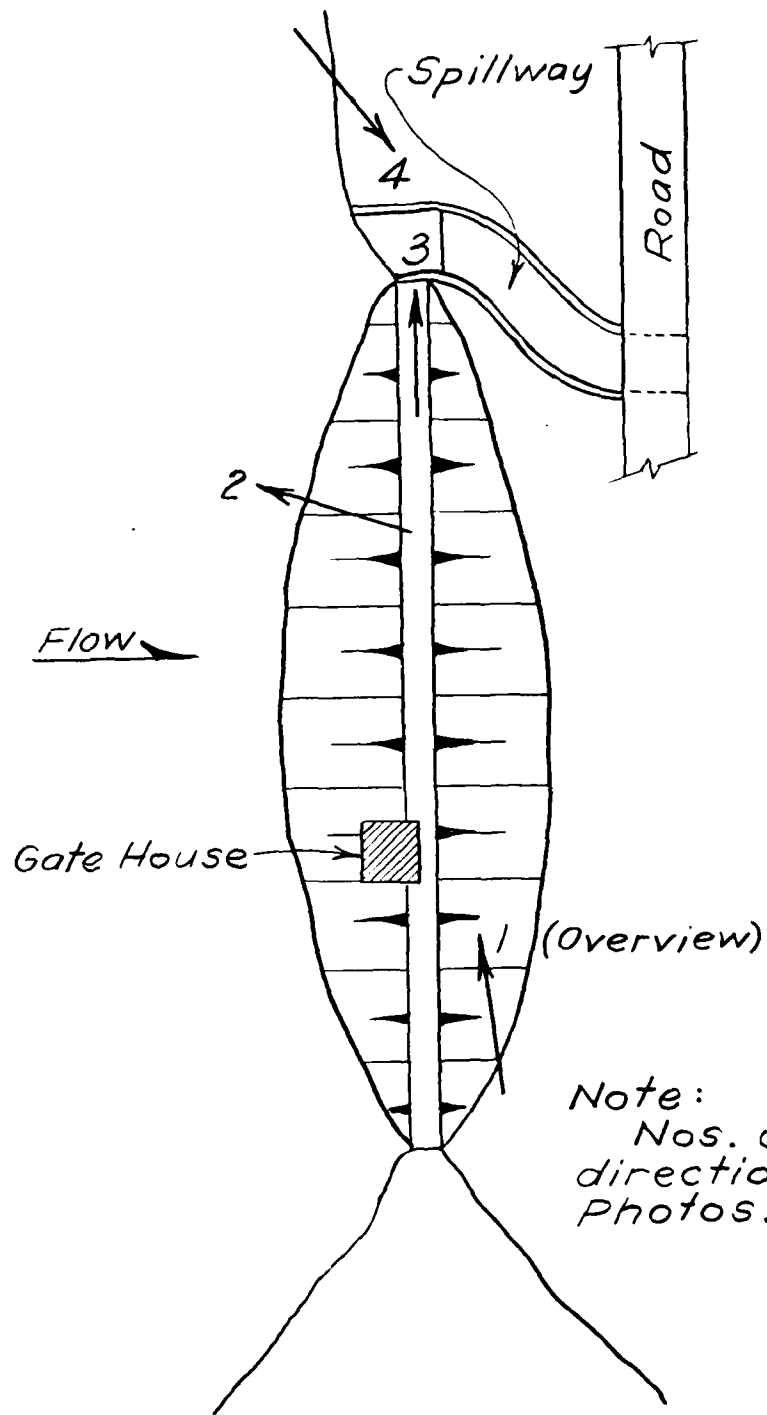

Note:
Nos. denote
direction of
Photos.

PLAN
WYMAN POND



Downstream Bank of Dam

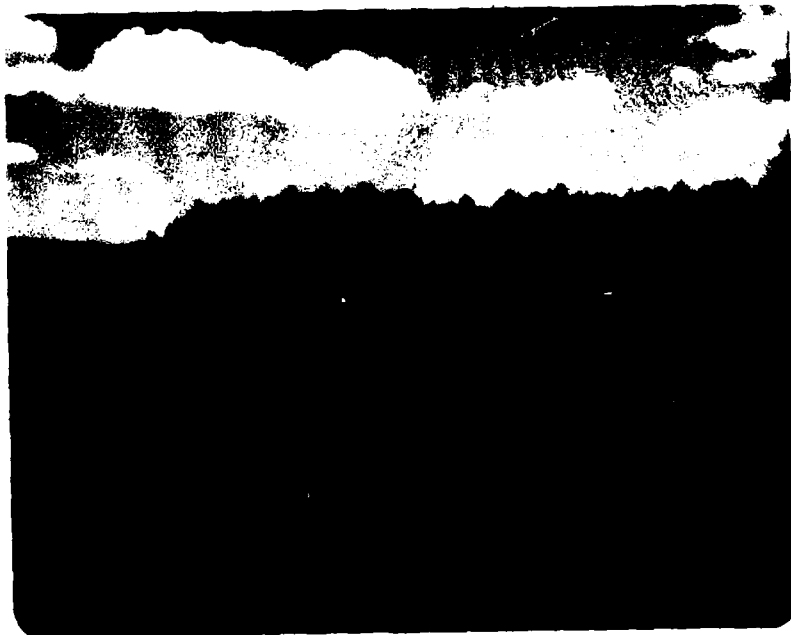

Upstream View of Reservoir

WYMAN DAM



3

View of Spillway from Top of Dam



4

Downstream View of Spillway Channel

WYMAN DAM

APPENDIX D

Client C O F E
 Subject WYMAN POND

Job No. 1345-065 Sheet 1 of 11
 By J. VEITCH Date 24 AUG. 1978
 Ckd. _____ Rev. _____

PMF = 13250 cfs
 D.A. = 4922 AC.
 R.A. = 326 AC.

HAZARD CLASS = 5/INT.

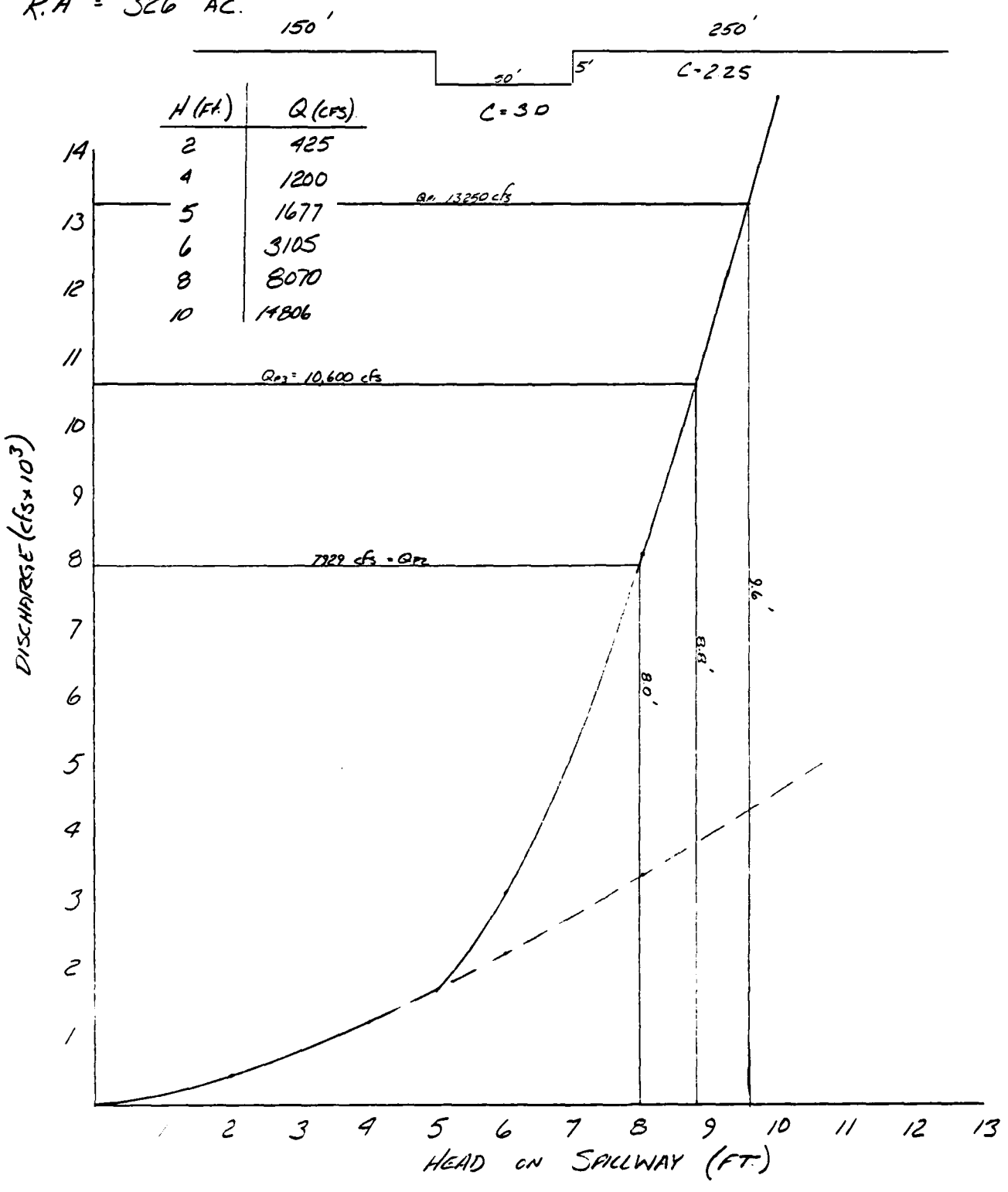

Client COFE
Subject WYMAN POND

Job No. 1345-065 Sheet 2 of 11
By J. VETICH Date 23 JULY 1989
Ckd. _____ Rev. _____

$$Q_{P1} = 13,250 \text{ cfs} \quad S_1 = 9.6'$$

$$\text{STOR}_1 = \frac{9.6(12)326}{7.69(640)} = 7.63''$$

$$Q_{P2} = 13,250 \left(1 - \frac{7.63}{19}\right) = 7929 \text{ cfs} \quad S_2 = 8.0'$$

$$\text{STOR}_2 = \frac{8.0(12)(326)}{7.69(640)} = 6.36'' \quad \text{STOR}_{\text{AVE.}} = 7.0''$$

$$S_{\text{AVE.}} = \frac{7.0(7.69)(640)}{12(326)} = 8.8' \Rightarrow \underline{Q_{P3} = 10,600 \text{ cfs.}}$$

DAM OVERTOPPED BY ~ 3.8' CASE I DAM INTACT.

$$\text{STORAGE} = S = 326(22)(.5) = 3586 \text{ AC FT}$$

$$Q_{P1} = \frac{8}{27} W_b \sqrt{32.2} y_o^{1.5}$$

$$= \frac{8}{27} (125) \sqrt{32.2} (16)^{1.5} = 13,450 \text{ cfs} = \text{P.F.O.}$$

$$W_b = 50\% \text{ Right Abot.} = 125'$$
$$y_o = 16'$$

CASE II FAILURE

$$\text{FAILURE FLOW} = 13450 \text{ cfs} + 1700 \text{ cfs (SAILWAY CAPACITY)}$$
$$= 15150 \text{ cfs.}$$

Client C O F E

Job No. 1345-065 Sheet 3 of 11

Subject WYMAN POND

By J. VEITCH Date 25 JULY 1973

Ckd. _____ Rev. _____

SECTION 1

LD

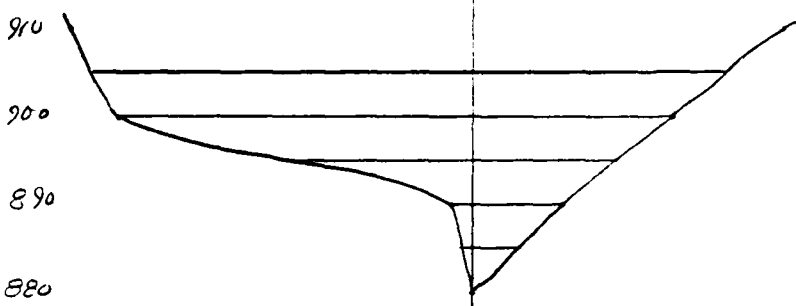

1" = 40' →
 1" = 20' ↓

SECTION 2.

1000'

920
 890
 880
 870
 860
 850

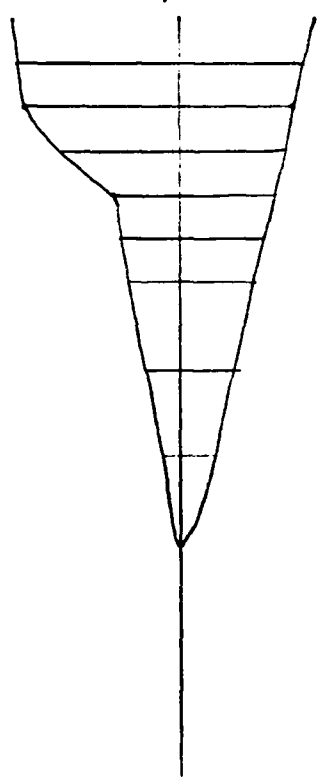

Client Cof E.

Job No. 1345-065 Sheet 4 of 11

Subject WYMAN POND

By J VEITEN Date 28 JULY 1979

Ckd. _____ Rev. _____

REACH #1 EL 860 $Q = 600 (23) \left(\frac{600}{160} \right)^{.67} (.03)^{.5} = 11,180 \text{ cfs}$

870 $Q = 2000 (23) \left(\frac{2000}{100} \right)^{.67} (.03)^{.5} = 59,000$

EL 880 $Q = 4200 (23) \left(\frac{4200}{140} \right)^{.67} (.03)^{.5} = 163,400$

$C = 23$

555 $Q = 188 (23) \left(\frac{188}{75} \right)^{.67} (.03)^{.5} = 1390$

$S = .03$

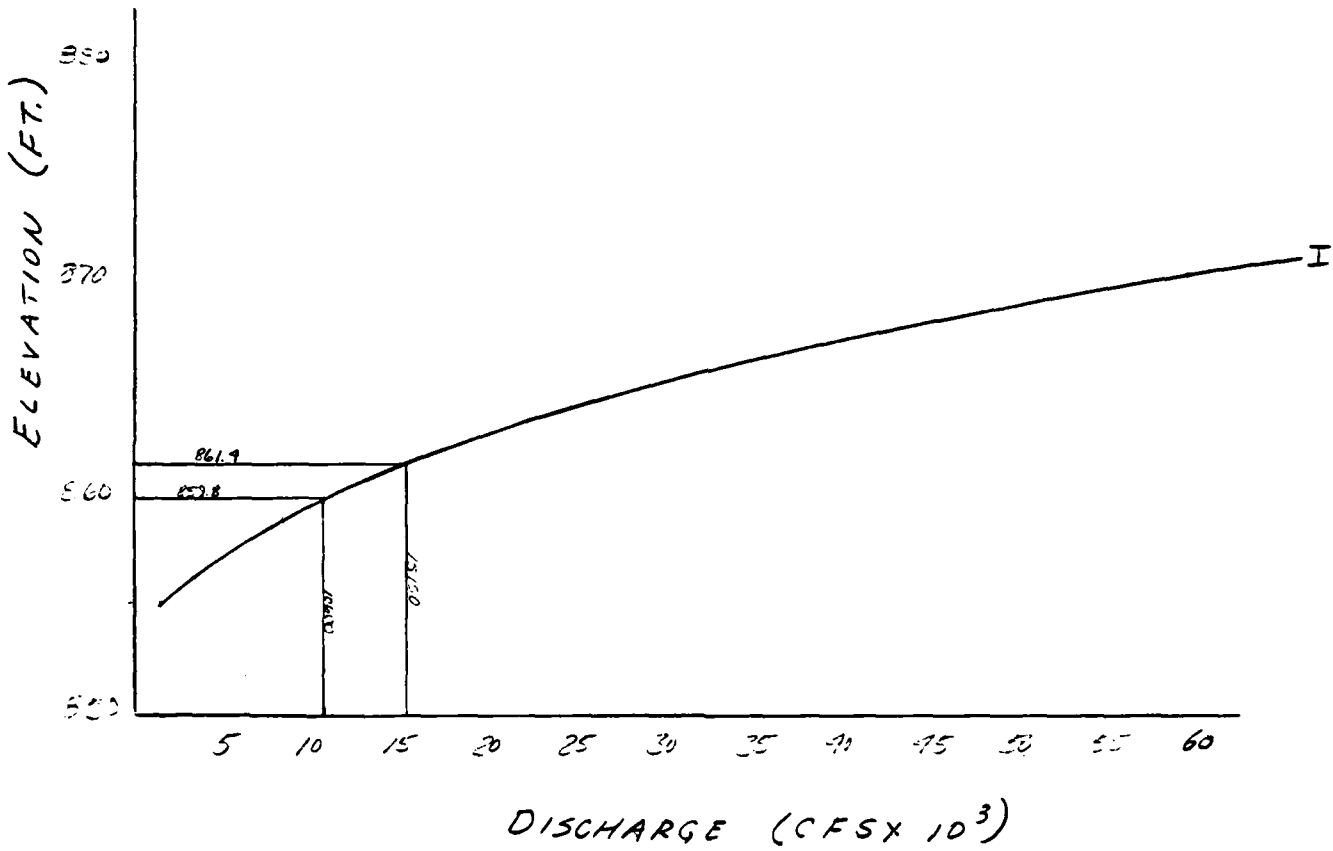

Client COF E
Subject WYMAN POND

Job No. 1345-065 Sheet 5 of 11
By J. VEITEN Date 25 JULY 1978
Ckd. _____ Rev. _____

CASE I. FHE DAM INTACT. $Q = 10,600 \text{ cfs}$
USING CURVE P 9.
REACH #1 AVE EL = 860.0

∴ NO HOMES IN DANGER, FLOODING TO NARROWS
ROAD AND INTERSECTION BELOW DAM. SLIGHT HAZARD TO HUMAN
LIFE. MANY LOW LYING HOMES AROUND LAKE SHORE FLOODED.

DOWNSTREAM - CHANNEL ENLARGES WATER WILL DISSIPATE & DISPER

CASE II. P.F.O. DAM FAILURE.

$Q = 15,150 \text{ cfs}$ AVE EL. = 861.4

SECTION #3 $\frac{100.0}{L.D.}$ 100 - 201

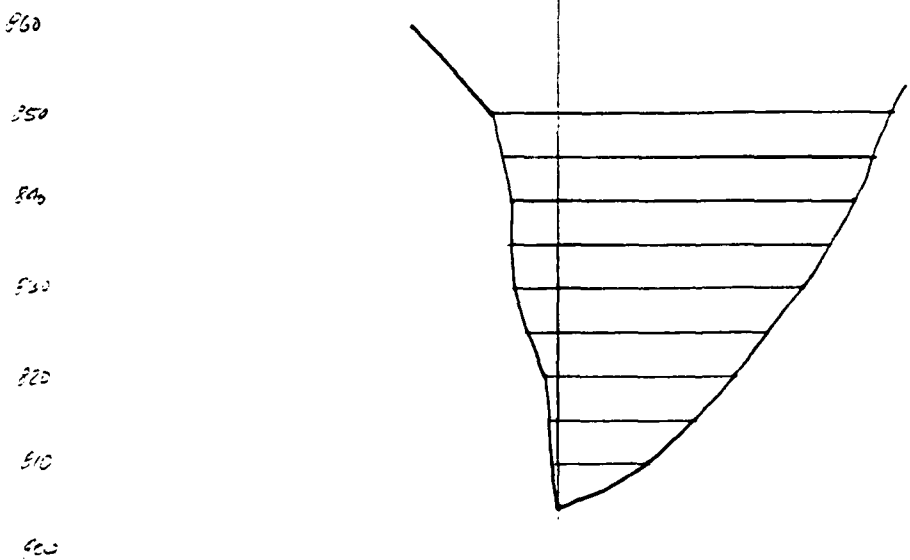

Client COFE
 Subject WYMAN POND

Job No. 1345-065 Sheet 6 of 11
 By J VEITCH Date 31 JULY 1978
 Ckd. _____ Rev. _____

$$\begin{aligned} \text{Reach \# 2} \quad 320 \quad Q &= 1612 \left(\frac{1612}{167} \right)^{1.47} (23) (0.95)^{1.47} = 48411 \\ 830 \quad Q &= 4063 \left(\frac{4063}{163} \right)^{1.47} (23) (0.95)^{1.47} = 170750 \\ 810 \quad Q &= 270 \left(\frac{270}{175} \right)^{1.47} (23) (0.95)^{1.47} = 1640 \end{aligned}$$

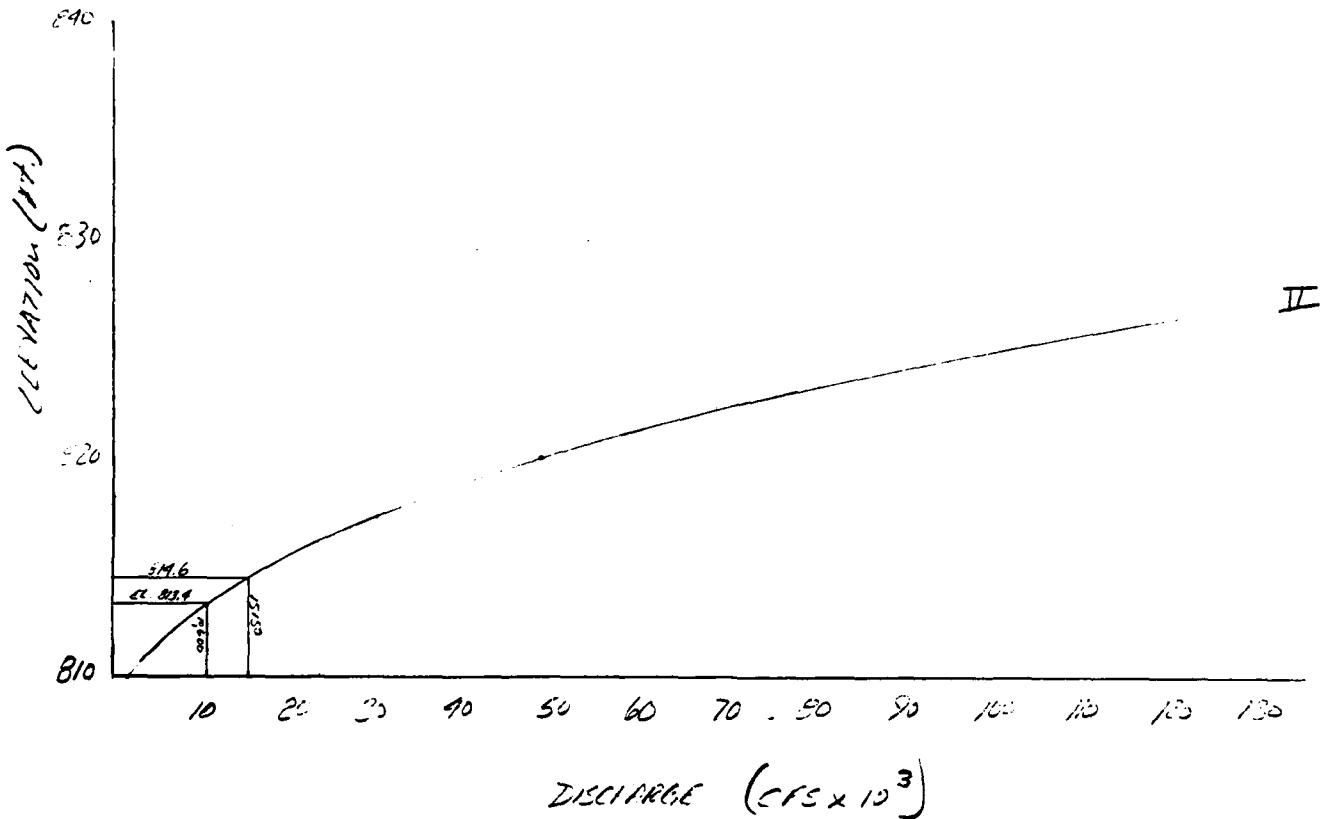

Client Civil
Subject WYMAN POND

Job No. 1345-065 Sheet 7 of 11
By J. Veitch Date 1 AUG. 1978
Ckd. _____ Rev. _____

CASE I. REACH I - 10,600 cfs AVE el = 830.0 V = 16' (326).5 = 31

$$V_1 = \frac{100(1000)}{43560} = 13.7 \text{ ACFT.}$$

$$Q_{P2} = 11,000 \left(1 - \frac{13.7}{2608}\right) = 10,600 \text{ cfs.} = Q_{P2}$$

REACH II - 10,600 cfs AVE el = 813.4

$$V_2 = \frac{13.9}{15} \left(\frac{807(1000)}{43560}\right) = 16.6 \text{ ACFT}$$

$$Q_{P2} = 10600 \left(1 - \frac{16.6}{2608}\right) = 10,533 \text{ cfs.}$$

SEE P. 5. DOWNSTREAM REACH.

CASE II. PEAK FAILURE OUTFLOW 15,150 cfs. REACH I
AVE EL. 861.4

$$V_1 = \frac{11.4}{20} \frac{200(1000)}{43560} = 26.2 \text{ ACFT.}$$

$$Q_{P2} (\text{TRIAL}) = 15150 \left(1 - \frac{26.2}{2608}\right) = 15,000 \text{ cfs.}$$

assume V_1 is correct $\therefore Q = 15150 \text{ cfs.}$

REACH II, Q = 15,150 AVE EL. = 814.6'

Flowing to homes on North side
of narrow road. Flow over top of
natural channel spreading through
heavily wooded channel.

Client C of E

Job No. 1345-065 Sheet 8 of 11

Subject WYMAN POND

By J. VEITCH Date 18 AUG 1978

Ckd. _____ Rev. _____

CULVERT UNDER NARROWS Rd

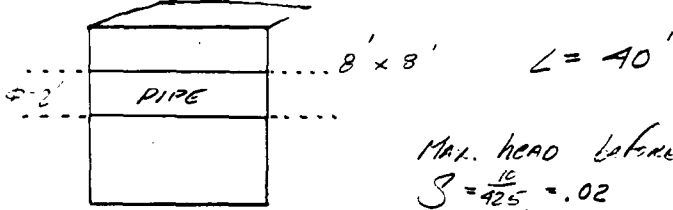

MAX. HEAD before ROAD OVERTOPPING 1'

$$S = \frac{16}{425} = .02 \quad A = -13^\circ$$

$$L = 40'$$

$$h = 5$$

$$C = .596$$

$$Q = Ca \sqrt{2gh}$$

$$= .596 (48) (\sqrt{64.4(5)}) = \underline{515 \text{ cfs}}$$

ASSUME ENTRANCE control
ASSUMED COEFFIC.

Client COF E
Subject WYMAN POND

Job No. 1345-065 Sheet 9 of 11
By J. VEITEN Date 23 AUG 1978
Ckd. _____ Rev. _____

ROAD PROFILE.

1" = 100' → 1" = 10'

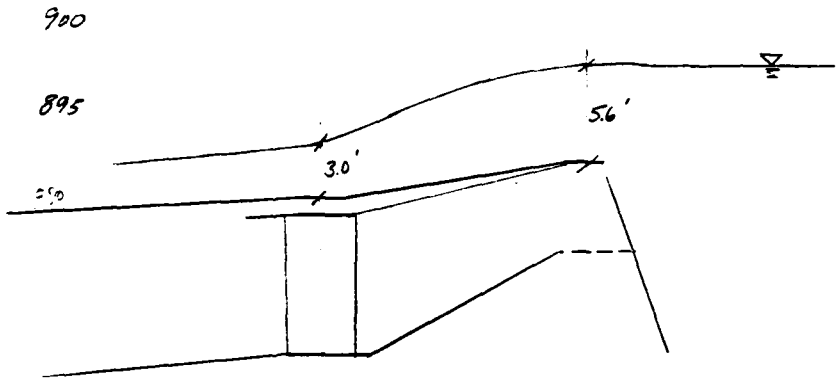
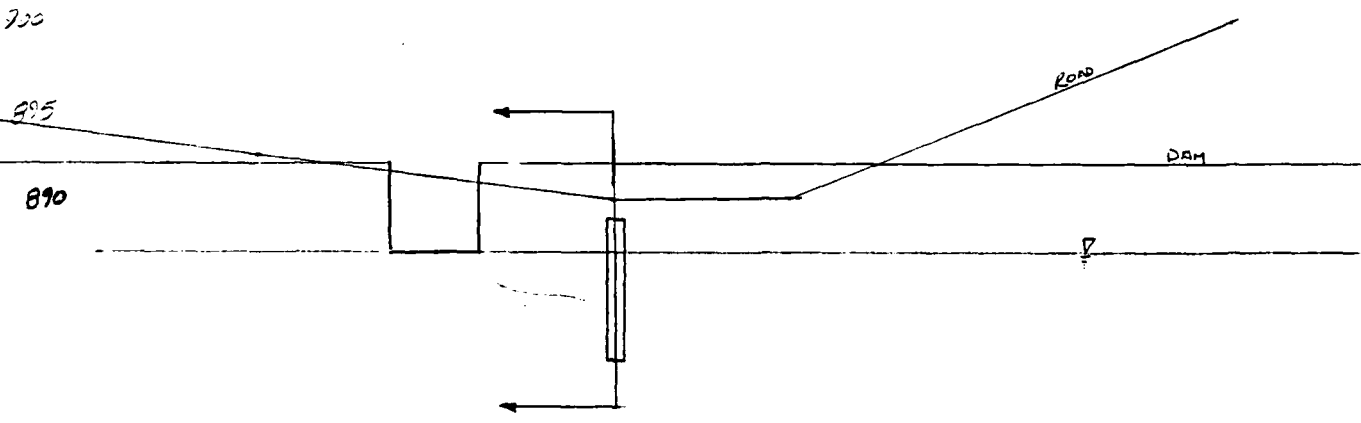

NEGLECTING SPILLWAY AT FLOOD LEVELS - HEAD TO PASS 13250 cfs
OVER CREST 5.6'

Client C of E Job No. 1345-065 Sheet 10 of 11
 Subject WYMAN POND By J VETTER Date 25 AUG 1978
P.F.O. ASSUMING WEIR FLOW OVER DAM Ckd. _____ Rev. _____
NEGLECTING SPILLING THROUGH
CHANNEL & UNDER ROAD

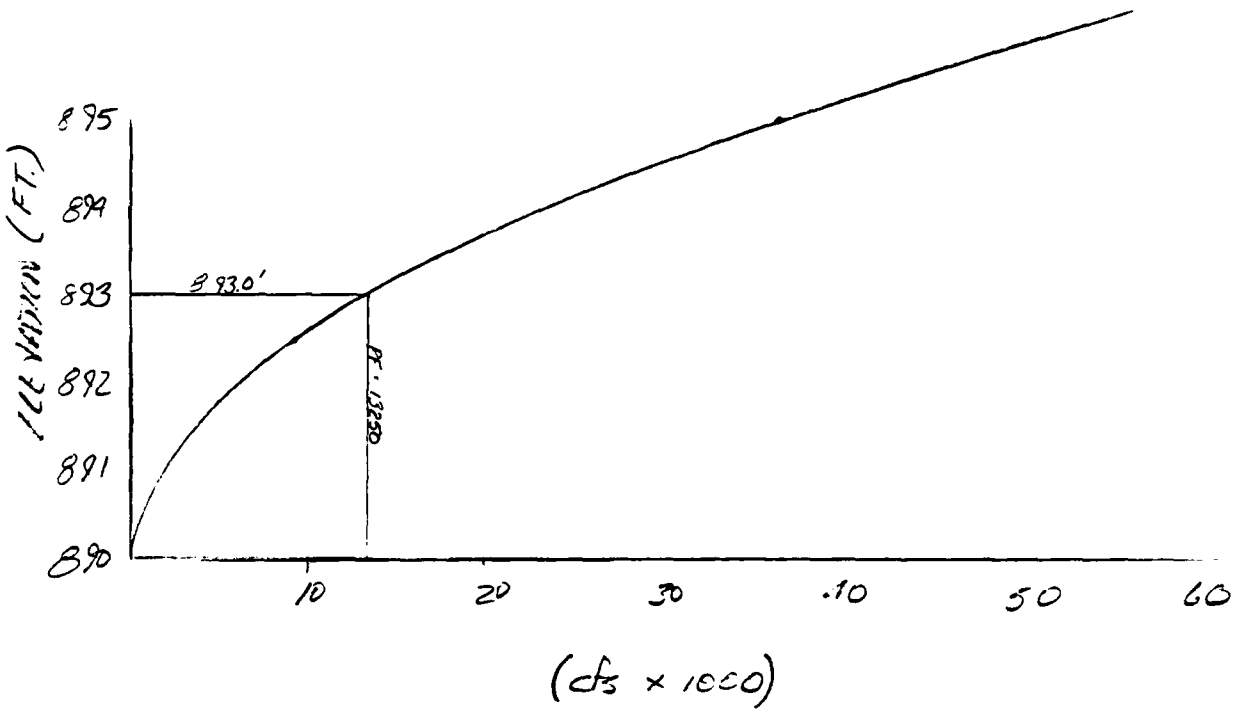

NEGLECTING SPILLWAY CHANNEL AND USING PMF OF 13250 cfs

Client C of E Job No. 1345-065 Sheet 11 of 11
Subject - WYMAN POND - By J. VEITCH Date 25 AUG. 1978
CAPACITY CURVE Ckd. _____ Rev. _____

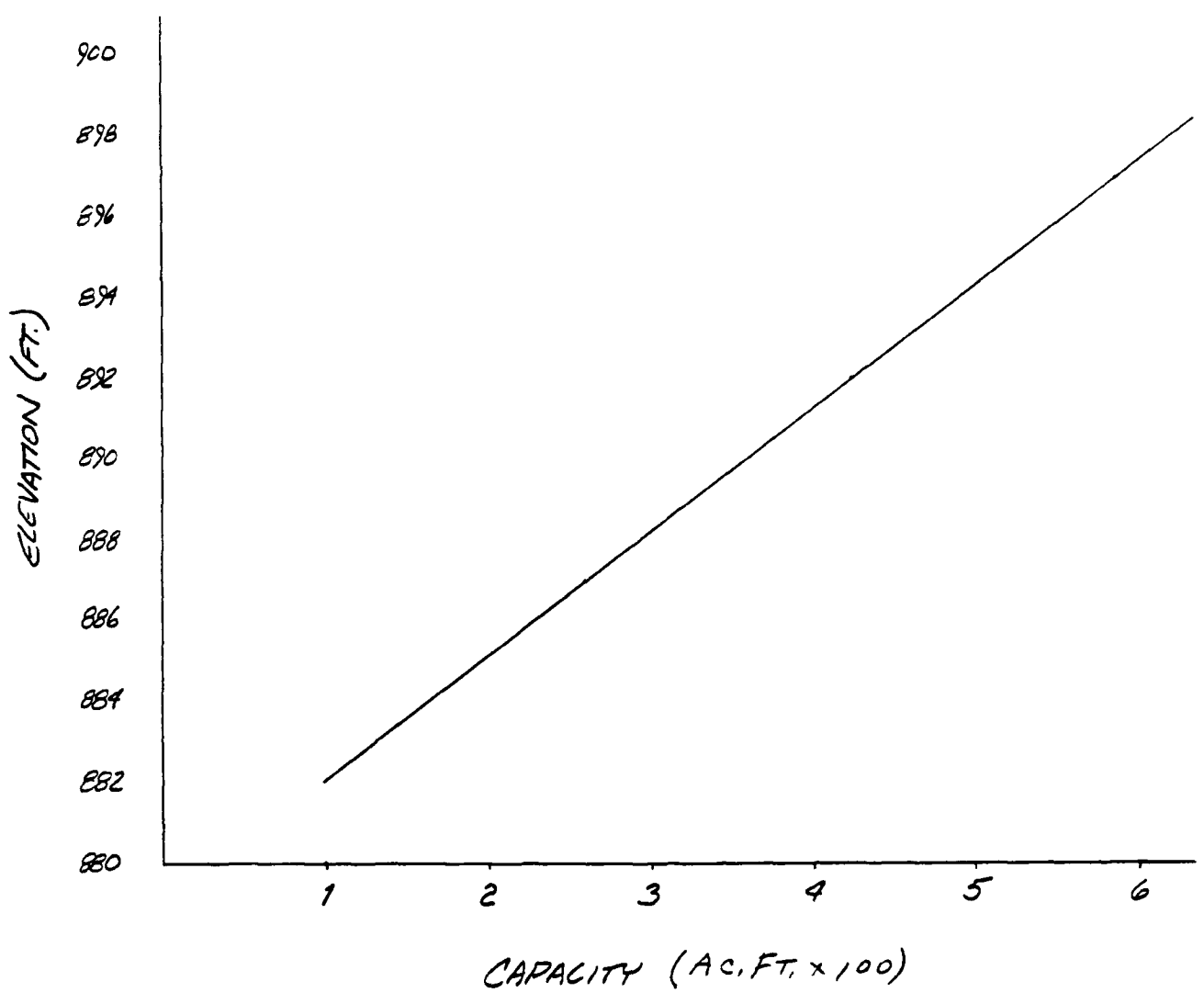

APPENDIX E



INVENTORY OF DAMS IN THE UNITED STATES

STATE	DIVISION	COUNTY	CONGR. DIST.	STATE	COUNTY	NAME	LATITUDE (NORTH)	LONGITUDE (WEST)	REPORT DATE
MA	641 NED	MA	027 04	MA	027 04	MYHAN POND DAM	4252.0	7152.6	08SEPT78

POPULAR NAME	NAME OF IMPOUNDMENT
MYHAN POND	MYHAN POND
REGION BASIN	NEAREST DOWNSTREAM CITY-TOWN-VILLAGE
01 06 TR FLAG BROOK	WESTMINSTER
	DIST FROM DAM (MI.)
	0
	POPULATION
	4300

TYPE OF DAM	YEAR COMPLETED	PURPOSES	HYDRAULIC HEIGHT (FT.)	IMPOUNDING CAPACITIES (ACRE-FT.)	DIST OWN	FED	R	N	N	VER/DATE
RECTPG	1900	SH	16	11	3200	1800	NED	N	N	30AUG78

REMARKS

D/S	HAS	SPILLWAY	MAXIMUM DISCHARGE (CFS)	VOLUME OF DAM (CU FT)	POWER CAPACITY (KW)	INSTALLED	PROPOSED	NO.	LENGTH (FT.)	WIDTH (FT.)	LENGTH (FT.)	WIDTH (FT.)	LENGTH (FT.)	WIDTH (FT.)
1	450	U	50	1675	13900									

OWNER	ENGINEERING BY
CITY OF FITCHBURG	CONSTRUCTION BY

DESIGN	REGULATORY AGENCY
NONE	CONSTRUCTION
	OPERATION
	MAINTENANCE
	NONE

INSPECTION BY	INSPECTION DATE
CHAS. T. MAIN, INC.	14 JUN 78
	AUTHORITY FOR INSPECTION
	P.L. 92-367

REMARKS

END

FILMED

7-85

DTIC