

REPORT DOCUMENTATION PAGE					
1a. REPORT SECURITY CLASSIFICATION UNCLASSIFIED		1b. RESTRICTIVE MARKINGS			
2a. SECURITY CLASSIFICATION AUTHORITY N/A		3. DISTRIBUTION/AVAILABILITY OF REPORT  Approved for Public Release; Distribution Unlimited			
2b. DECLASSIFICATION/DOWNGRADING SCHEDULE N/A					
4. PERFORMING ORGANIZATION REPORT NUMBER(S)		5. MONITORING ORGANIZATION REPORT NUMBER(S)  AFWAL-TR-84-3116			
6a. NAME OF PERFORMING ORGANIZATION AIRTECH PRECISION SHOT PEENING, INC.		6b. OFFICE SYMBOL (If applicable)	7a. NAME OF MONITORING ORGANIZATION FLIGHT DYNAMICS LABORATORY AF WRIGHT AERONAUTICAL LABORATORIES		
6c. ADDRESS (City, State and ZIP Code) 36656 COMMERCE ROAD LIVONIA, MI 48150		7b. ADDRESS (City, State and ZIP Code) WPAFB, OH 45433			
8a. NAME OF FUNDING/SPONSORING ORGANIZATION AF WRIGHT AERONAUTICAL LAB. FLIGHT DYNAMICS LABORATORY		8b. OFFICE SYMBOL (If applicable) AFWAL/FIBA	9. PROCUREMENT INSTRUMENT IDENTIFICATION NUMBER  F33615-83-C-3252		
8c. ADDRESS (City, State and ZIP Code)  WPAFB, OH. 45433		10. SOURCE OF FUNDING NOS.			
11. TITLE (Include Security Classification) (ON REVERSE SIDE)		PROGRAM ELEMENT NO.	PROJECT NO.	TASK NO.	WORK UNIT NO.
		61102F	3005	30	01
12. PERSONAL AUTHOR(S) ROGER S. SIMPSON AND JOHN T. CAMMETT, III					
13a. TYPE OF REPORT FINAL		13b. TIME COVERED FROM 9/83 TO 4/84	14. DATE OF REPORT (Yr., Mo., Day) April 1985	15. PAGE COUNT 41	
16. SUPPLEMENTARY NOTATION					
17. COSATI CODES		18. SUBJECT TERMS (Continue on reverse if necessary and identify by block number)  SHOT PEENING, FATIGUE, FATIGUE LIFE, RESIDUAL STRESS, METAL, ALUMINUM			
FIELD	GROUP				SUB. GR.
19. ABSTRACT (Continue on reverse if necessary and identify by block number)  SHOT PEENING IS USED EXTENSIVELY IN MANY AIRCRAFT STRUCTURAL AND ENGINE APPLICATIONS TO ENHANCE FATIGUE LIFE AND STRESS CORROSION RESISTANCE. RECENT RESEARCH INDICATES THAT HIGH SHOT PEENING INTENSITIES CAN PRODUCE A PHENOMENON CALLED PEENED SURFACE EXTRUSION FOLDS (PSEF) WHICH IS HYPOTHESIZED TO RESULT IN FATIGUE LIFE REDUCTIONS. IN THIS INVESTIGATION MORE THAN ONE HUNDRED SPECIMENS OF 7075-T6 AND 7075-T73 ALUMINUM MATERIAL WERE MANUFACTURED AND TREATED AT VARIOUS LEVELS OF SHOT PEENING INTENSITY, ALMEN SATURATION LEVEL, AND PEENING MEDIA SIZE. SPECIMENS WERE SUBSEQUENTLY FATIGUE TESTED UNDER AXIAL LOADING CONDITIONS. THE LONGEST FATIGUE LIFE WAS OBTAINED AT RELATIVELY LOW ALMEN INTENSITIES WITH THE SMALLEST SIZE GLASS BEAD AT 100-110% ALMEN SATURATION. INTENSITY vs FATIGUE LIFE PATTERNS WERE SIMILAR FOR BOTH MATERIALS. THE OPTIMUM INTENSITY LEVEL WAS SUBSTANTIALLY BELOW THAT SPECIFIED IN MIL-STD-852. SCANNING ELECTRON MICROSCOPY AND METALLOGRAPHY SHOWED INCREASING DEPTH AND QUANTITY OF PSEF AND EMBEDDED GLASS LEAD PARTICLES AT THE SURFACE AS PEENING INTENSITY INCREASED.					
20. DISTRIBUTION/AVAILABILITY OF ABSTRACT  UNCLASSIFIED/UNLIMITED <input checked="" type="checkbox"/> SAME AS RPT. <input type="checkbox"/> DTIC USERS <input type="checkbox"/>		21. ABSTRACT SECURITY CLASSIFICATION  UNCLASSIFIED			
22a. NAME OF RESPONSIBLE INDIVIDUAL  JOHN M. POTTER		22b. TELEPHONE NUMBER (Include Area Code) 513-255-6639	22c. OFFICE SYMBOL AFWAL/FIBA		

11. TITLE: "DEVELOPMENT OF A MATHEMATICAL MODEL FOR PREDICTING THE PERCENTAGE FATIGUE LIFE INCREASE RESULTING FROM SHOT PEENED COMPONENTS, PHASE I"

19. ABSTRACT:

TEST WORK DEMONSTRATED STATISTICALLY SIGNIFICANT EFFECTS OF PSEF, EMBEDDED GLASS PARTICLES, PERCENT OF ALMEN SATURATION, PART MATERIAL HARDNESS, AND PEENING MEDIA SIZE ON SPECIMEN FATIGUE LIFE. MULTIPLE LINEAR STATISTICAL REGRESSION OF THESE FOUR VARIABLES ACCOUNTED FOR A HIGH PERCENTAGE OF THE VARIANCE IN SPECIMEN FATIGUE LIFE.

AFWAL-TR-84 -3116



DEVELOPMENT OF A MATHEMATICAL MODEL FOR PREDICTING  
THE PERCENTAGE FATIGUE LIFE INCREASE RESULTING FROM  
SHOT PEENED COMPONENTS, PHASE I.

Roger S. Simpson  
Airtech Precision Shot Peening, Inc.  
36656 Commerce  
Livonia, MI 48150

April 1985

Final Report for Period September 1983 - April 1984

Approved for public release; distribution unlimited

FLIGHT DYNAMICS LABORATORY  
// AIR FORCE WRIGHT AERONAUTICAL LABORATORIES •  
AIR FORCE SYSTEMS COMMAND  
WRIGHT-PATTERSON AFB, OHIO 45433

NOTICE

When Government drawings, specifications, or other data are used for any purpose other than in connection with a definitely related Government procurement operation, the United States Government thereby incurs no responsibility nor any obligation whatsoever; and the fact that the government may have formulated, furnished, or in any way supplied the said drawings, specifications, or other data, is not to be regarded by implication or otherwise as in any manner licensing the holder or any other person or corporation, or conveying any rights or permission to manufacture use, or sell any patented invention that may in any way be related thereto.

This report has been reviewed by the Office of Public Affairs (ASD/PA) and is releasable to the National Technical Information Service (NTIS). At NTIS, it will be available to the general public, including foreign nations.

This technical report has been reviewed and is approved for publication.

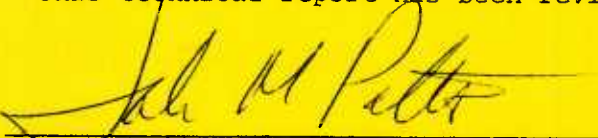
  
\_\_\_\_\_  
JOHN M. POTTER, Project Engineer  
Fatigue, Fracture & Reliability Group  
Structural Integrity Branch

  
\_\_\_\_\_  
TONY G. GERARDI, Chief  
Structural Integrity Branch  
Structures & Dynamics Division

FOR THE COMMANDER

  
\_\_\_\_\_  
ROGER J. HEGSTROM, Colonel, USAF  
Chief, Structures and Dynamics Division  
Flight Dynamics Laboratory

"If your address has changed, if you wish to be removed from our mailing list, or if the addressee is no longer employed by your organization please notify FIBEC, W-PAFB, OH 45433 to help us maintain a current mailing list".

Copies of this report should not be returned unless return is required by security considerations, contractual obligations, or notice on a specific document.

## FOREWORD

THIS TECHNICAL REPORT WAS PREPARED BY ROGER S. SIMPSON OF AIRTECH PRECISION SHOT PEENING, INC. AND DR. JOHN T. CAMMETT III OF METCUT RESEARCH ASSOCIATES. THE WORK FOR THIS REPORT WAS PERFORMED AT AIRTECH PRECISION SHOT PEENING, INC. IN LIVONIA, MICHIGAN AND METCUT RESEARCH ASSOCIATES IN CINCINNATI, OHIO DURING THE PERIOD SEPTEMBER, 1983 TO APRIL, 1984. DR. CAMMETT AND MR. SIMPSON WISH TO TAKE THIS OPPORTUNITY TO THANK THOSE WHO CONTRIBUTED SUBSTANTIALLY TO THIS REPORT:

MR. LUCIANO GATTO OF METCUT RESEARCH ASSOCIATES  
MR. RICHARD SIMPSON OF AIRTECH PRECISION SHOT PEENING, INC.  
MR. GORDON CHIASSON OF AIRTECH PRECISION SHOT PEENING, INC.  
DR. JOHN POTTER OF FLIGHT DYNAMICS LABORATORY, AFWAL, WPAFB  
MR. PETER MOLONEY OF MADONNA COLLEGE MATHEMATICS DEPARTMENT  
MR. WILLIAM STROSS OF METCUT RESEARCH ASSOCIATES

THIS REPORT WAS SUBMITTED BY THE AUTHORS IN APRIL 1985

TABLE OF CONTENTS

SECTION		PAGE
1.0	INTRODUCTION .....	1
2.0	PROCEDURE	
	2.1 TEST CONDITIONS.....	3
	2.2 SPECIMEN GROUPS.....	4
	2.3 PREPARATION OF TEST SPECIMENS.....	5
	2.4 SHOT PEENING.....	6
	2.5 FATIGUE TESTING.....	7
	2.6 POST TEST SPECIMEN EXAMINATION.....	7
3.0	STATISTICAL OVERVIEW.....	8
4.0	PRESENTATION OF RESULTS AND ANALYSIS.....	9
5.0	DISCUSSION.....	24
	5.1 SUMMARY.....	31
6.0	CONCLUSIONS.....	31
7.0	RECOMMENDATIONS.....	32
	REFERENCES.....	33
 <u>APPENDICES</u>		
	A. SPECIMEN GEOMETRY.....	35
	B. RESIDUAL STRESS PROFILES.....	37

LIST OF FIGURES

FIGURE		PAGE
1:	FATIGUE LIFE vs ALMEN INTENSITY 7075-T6 ALUMINUM ALLOY.....	12
2:	FATIGUE LIFE vs ALMEN INTENSITY 7075-T73 ALUMINUM ALLOY.....	14
3:	NO. SEC. FAIL. SITES vs ALMEN INTENSITY 7075-T6 ALUMINUM ALLOY.....	17
4:	PSEF DEPTH vs ALMEN INTENSITY 7075-T6 ALUMINUM ALLOY.....	18
5:	PSEF DEPTH vs ALMEN INTENSITY 7075-T73 ALUMINUM ALLOY.....	19
6:	MEDIA SIZE vs FATIGUE LIFE 7075-T6 ALUMINUM ALLOY.....	22

TABLE	LIST OF TABLES	PAGE
1.	SPECIMEN GROUPS AND SHOT PEENING PARAMETERS.....	4
2.	SUMMARY OF FATIGUE LIFE DATA 7075-T6, ROOM TEMPERATURE, 50 KSI MAX. STRESS, R = 0.1 (AXIAL)...	11
3.	SUMMARY OF FATIGUE LIFE DATA 7075-T73, ROOM TEMPERATURE, 45 KSI MAX. STRESS, R = 0.1 (AXIAL)...	13
4.	NO. FATIGUE SITES vs ALMEN INTENSITY 7075-T6 ALUMINUM ALLOY.....	15
5.	PSEF DEPTH vs ALMEN INTENSITY 7075-T6 ALUMINUM ALLOY.....	15
6.	PSEF DEPTH vs ALMEN INTENSITY 7075-T73 ALUMINUM ALLOY.....	16
7.	CRACK NUCLEATION LOCATION, 7075-T73 ALUMINUM ALLOY.	21
8.	CRACK NUCLEATION LOCATION, 7075-T6 ALUMINUM ALLOY..	23
9.	ALMEN INTENSITY vs FAILURE LOCATION.....	23
10.	PSEF vs FAILURE LOCATION.....	23

## 1.0 INTRODUCTION

SHOT PEENING IS USED EXTENSIVELY IN AEROSPACE AND OTHER INDUSTRIES AS A MEANS FOR EXTENDING THE FATIGUE LIFE OR INCREASING THE STRESS CORROSION RESISTANCE OF COMPONENTS SUBJECTED TO CYCLIC TENSILE LOADS. FATIGUE LIFE INCREASES OF 300-500 PERCENT AND STRESS CORROSION RESISTANCE INCREASES OF TEN TIMES THAT AMOUNT ARE NOT UNCOMMON (REF. 16-22). THERE IS, HOWEVER, A SUBSTANTIAL AMOUNT OF THE VARIABLE INTERACTION IN SHOT PEENING WHICH REMAINS UNDESCRIBED OR UNEXPLAINED. AVAILABLE LITERATURE CONCERNING THE EFFECTS ON COMPONENT LIFE OF PEENING VARIABLES, INCLUDING ALMEN INTENSITY, SHOT IMPACT ANGLE, SHOT SIZE AND ALMEN SATURATION LEVELS, IS SPARSE AT BEST. THIS DEARTH OF INFORMATION IS COMPOUNDED BY A LACK OF CONTROL OF VARIABLES IN MANY ACTUAL PRODUCTION PEENING APPLICATIONS.

IN TEST WORK ASSOCIATED WITH A SHOT PEENING APPLICATION ON 7075-T6 COMPONENTS DURING A MAJOR AIRFRAME OVERHAUL ON USAF C-141 AIRCRAFT, A POTENTIAL PROBLEM WAS IDENTIFIED. AT INTENSITY LEVELS WITHIN THOSE PRESCRIBED BY MIL-STD-852 AND SUBSTANTIALLY BELOW THOSE EXPERIENCED DURING OVERHAUL OPERATIONS, 7075-T6 PEENED SURFACES EXHIBITED RELATIVELY DEEP LAPS ON THE PEENED SURFACE. THESE LAPS SEEMED TO BE ASSOCIATED WITH THE PERIPHERY OF SHOT IMPINGEMENTS ON THE WORKPIECE. AT THESE INTENSITIES, THE DEPTH OF THESE LAPS WAS A HIGH PERCENTAGE OF THE TOTAL DEPTH OF PLASTIC DEFORMATION AND THEIR ORIENTATION WAS ROUGHLY 75 DEG/90 DEG TO THE SURFACE. THIS PROBLEM WAS BROUGHT TO THE ATTENTION OF THE AIR FORCE WRIGHT AERONAUTICAL LABORATORY AT WRIGHT PATTERSON AIR FORCE BASE ALONG WITH DATA PUBLISHED AT THE FIRST INTERNATIONAL CONFERENCE ON SHOT PEENING AND THE 1983 SAE AEROSPACE CONGRESS. THIS DATA ALONG WITH DATA DEVELOPED FOR AIRTECH PRECISION SHOT PEENING, INC. BY METCUT RESEARCH SUGGESTED THE FOLLOWING:

- A) RELATIVELY LOW SHOT PEENING INTENSITIES THAT GAVE VERY LITTLE INDICATION OF SURFACE LAPS IN AIRTECH'S STUDIES ALSO EXHIBITED HIGHER FATIGUE LIFE THAN INTENSITIES LISTED IN APPLICABLE U.S. MILITARY SPECIFICATIONS FOR SHOT PEENING OF ALUMINUM.
- B) MULTIPLES OF 100% SATURATION COMMONLY SPECIFIED IN AEROSPACE PEENING SPECIFICATIONS MAY BE DELETERIOUS TO FATIGUE LIFE IN SOME MATERIALS AND PEENING APPLICATIONS.
- C) SMALLER PEENING MEDIA (SHOT OR BEAD) SIZES YIELDED HIGHER FATIGUE LIFE THAN LARGER SIZES FOR A GIVEN INTENSITY.

- D) LOWER ALMEN INTENSITIES YIELDED GREATER SURFACE RESIDUAL COMPRESSIVE STRESS THAN DID HIGHER INTENSITIES.
- E) FATIGUE LIFE AND PEENING INTENSITY HAD A POSITIVE CORRELATION AS INTENSITY ROSE TO AN OPTIMUM VALUE BEYOND WHICH THE CORRELATION BECAME INVERSE.
- F) THE FATIGUE LIFE OF COMPONENTS PEENED AT INTENSITY AND SATURATION LEVELS ABOVE THE OPTIMUM COULD BE REDUCED BY AS MUCH AS 50%.
- G) SHOT PEENING OF OTHER RELATIVELY DUCTILE MATERIALS SUCH AS TITANIUM AT HIGH ALMEN INTENSITIES COULD YIELD LOWER FATIGUE LIFE THAN UNPEENED. MUCH OF THIS INFORMATION POINTED TO THE SURFACE LAPS IDENTIFIED BY AIRTECH AS POTENTIALLY CAUSAL TO THESE PHENOMENA. IN ORDER TO DIFFERENTIATE THESE LAPS FROM MACHINING OR OTHER LAPS THAT MAY BE PRESENT ON MACHINED SPECIMENS, THEY WERE GIVEN THE TITLE: PEENED SURFACE EXTRUSION FOLDS (PSEF). (SEE REFERENCES 5, 6, 7, AND 8)

THE QUESTIONS THAT AROSE CONCERNING PSEF AND ITS EFFECT ON COMPONENT FATIGUE LIFE WERE AS FOLLOWS:

- A) ARE PSEF AND THE PEAKING OF FATIGUE LIFE AT AN OPTIMUM INTENSITY LEVEL FOR A GIVEN MATERIAL RELATED?
- B) WHAT VARIABLES AFFECT PSEF FORMATION?

THE GOAL OF THIS PROJECT WAS TO DETERMINE IF PSEF WAS RELATED TO DECREASES IN FATIGUE LIFE AT RELATIVELY HIGH PEENING INTENSITIES. IF SO, STATISTICAL DEFINITION OF THIS RELATIONSHIP IN TERMS OF CRACK NUCLEATION AND PROPAGATION WAS SOUGHT.

THE MAGNITUDE OF SUCH A STUDY IS COMPOUNDED BY THE MANY PEENING VARIABLES AND NUMEROUS LEVELS WITHIN EACH VARIABLE. THE VARIABLES OF ALMEN INTENSITY, ALMEN SATURATION LEVEL, AND PEENING MEDIA-SIZE WERE CHOSEN TO BE STUDIED BECAUSE THEY ARE CENTRAL TO SHOT PEENING TECHNOLOGY.

SPECIMENS CHOSEN WERE AXIAL SMOOTH FATIGUE SPECIMENS, BASED ON THE GENERAL OBJECTIVES OF THE STUDY WHICH WAS TO DETERMINE GENERAL TRENDS, NOTCHED SPECIMENS WERE REJECTED BECAUSE OF THE POSSIBILITY THAT THEY WOULD YIELD OVERLY SPECIFIC RESULTS.

## 2.0 PROCEDURE

### 2.1 TEST CONDITIONS

TEST CONDITIONS WERE CHOSEN ON THE BASIS OF THE CRITERIA LISTED BELOW.

1. 7075-T6 AND 7075-T73 WERE SELECTED AS WORKPIECE MATERIALS BASED ON THE FOLLOWING:
  - A) PRELIMINARY TEST WORK HAD BEEN CONDUCTED WITH 7075-T6 (REFERENCE 11, 12)
  - B) IT WAS HYPOTHESIZED THAT HARDNESS AND DUCTILITY WOULD AFFECT THE FORMATION OF PSEF. 7075-T73 WAS CHOSEN PRIMARILY FOR COMPARITIVE ANALYSIS WITH 7075-T6 AND AS SUCH HAD FEWER SPECIMENS TESTED.
  - C) THE AIR FORCE USES BOTH MATERIALS IN MANY AIRCRAFT APPLICATIONS.
2. GLASS BEADS WERE CHOSEN DUE TO THEIR CHEMICAL INERTNESS AND WIDESPREAD USE IN ALUMINUM PEENING APPLICATIONS.
3. GLASS BEAD SIZES WERE CHOSEN TO PROVIDE A SPECTRUM OF INTENSITY CONDITIONS AT EACH OF WHICH THREE SIZES OF GLASS BEADS WERE USED. SIZES NEEDED TO BE DIFFERENT ENOUGH TO CLEARLY DEMONSTRATE THE EFFECTS, IF ANY, OF MEDIA SIZE ON COMPONENT FATIGUE LIFE AT A GIVEN INTENSITY. CHOOSING MEDIA SIZES TOO WIDELY SPACED COULD PRECLUDE OBTAINING THE REQUIRED INTENSITY AT THE HIGHER INTENSITY LEVEL AS THE PEENING EQUIPMENT AT SOME POINT BECOMES UNABLE TO GENERATE HIGH ENOUGH MEDIA VELOCITIES TO ACHIEVE RELATIVELY HIGH INTENSITIES WITH THE SMALLER BEAD SIZES.
4. ALMEN INTENSITY LEVELS WERE TO REPRESENT INCREMENTALLY INCREASING INTENSITY CONDITIONS. ALMEN INTENSITY INCREMENTS OF .002 WERE CHOSEN AS THIS WOULD ALLOW CLOSE IDENTIFICATION OF OPTIMUM INTENSITY WITHOUT THE REDUNDANCY OF .001 INCREMENTS.
5. VARYING ALMEN SATURATION LEVELS HAD GIVEN VARYING SURFACE INTEGRITY DURING PRELIMINARY TEST WORK AND SEM EXAMINATIONS. IT WAS HYPOTHESIZED THAT THESE WOULD YIELD VARYING FATIGUE LIVES. SATURATION LEVEL VARIABLES WERE TO BE EXAMINED AT OPTIMUM AND LEAST OPTIMUM INTENSITY LEVELS TO BALANCE FOR THE EFFECT OF INTENSITY.

## 2.2 SPECIMEN GROUPS

TABLE 1  
SPECIMEN GROUPS AND SHOT PEENING PARAMETERS

GROUP	NO. SPECIMENS	MATERIAL	ALMEN INTENSITY	BEAD SIZE	PERCENT SATURATION
A, 1	2	7075-T6	1A	MIL-8	100
A, 2	3	7075-T6	1A	MIL-6	100
A, 3	3	7075-T6	1A	MIL-4	100
B, 1	3	7075-T6	3A	MIL-8	100
B, 2	3	7075-T6	3A	MIL-6	100
B, 3	3	7075-T6	3A	MIL-4	100
C, 1	3	7075-T6	5A	MIL-8	100
C, 2	3	7075-T6	5A	MIL-6	100
C, 3	3	7075-T6	5A	MIL-4	100
D, 1	3	7075-T6	7A	MIL-5	100
D, 3	3	7075-T6	7A	MIL-3	100
E, 1	3	7075-T6	9A	MIL-5	100
E, 2	3	7075-T6	9A	MIL-4	100
E, 3	3	7075-T6	9A	MIL-3	100
F, 1	3	7075-T6	11A	MIL-5	100
F, 2	3	7075-T6	11A	MIL-4	100
F, 3	3	7075-T6	11A	MIL-3	100
G, 1	3	7075-T6	13A	MIL-3	100
H, 1	3	7075-T6	15A	MIL-3	100
I, 1	1	7075-T73	1A	MIL-8	100
J, 1	1	7075-T73	3A	MIL-8	100
K, 1	2	7075-T73	5A	MIL-8	100
L, 1	2	7075-T73	7A	MIL-5	100
M, 1	2	7075-T73	9A	MIL-5	100
N, 1	3	7075-T73	11A	MIL-5	100
O, 1	3	7075-T73	13A	MIL-3	100
P, 1	3	7075-T73	15A	MIL-3	100
Q, 1	2	7075-T6	3A	MIL-8	200
R, 1	2	7075-T6	3A	MIL-8	300
S, 1	2	7075-T73	17A	MIL-3	100
T, 1	2	7075-T73	20A	MIL-3	100
U, 1	2	7075-T73	20A	MIL-3	200
Z, 3	3	7075-T6	20A	MIL-3	100

### 2.3 PREPARATION OF TEST SPECIMENS

1. AXIAL TEST SPECIMENS WERE MACHINED FROM 7075-T6 AND 7075-T73.
2. MACHINING WAS ACCOMPLISHED BY SPIN MANUFACTURING INC. OF FARMINGTON, MICHIGAN ON A TRACER LATHE TO A FINISH OF 65 MICRO-INCHES AA.
3. SPECIMENS WERE SUBSEQUENTLY POLISHED TO A FINISH OF 8-10 MICRO-INCHES AA.
4. SPECIMENS WERE NON-DESTRUCTIVELY INSPECTED FOR CRACKS OR FLAWS BY NORWOOD PRECISION PRODUCTS, INC. OF MELVINDALE, MICHIGAN, A COMPANY CERTIFIED IN AEROSPACE NON-DESTRUCTIVE TEST METHODS.

## 2.4 SHOT PEENING

1. ALL PEENING WAS PER MIL-S-13165B, UNLESS OTHERWISE SPECIFIED.
2. ALL SHOT PEENING IMPACT ANGLES WERE HELD CONSTANT AT 90 +/- 2 DEGREES.
3. ALL SHOT PEENING ALMEN SATURATION LEVELS WERE PRIOR CALCULATED TO YIELD 100-110% UNLESS OTHERWISE SPECIFIED.
4. ALL INTENSITY CURVES HAD A MINIMUM OF 6 POINTS PLOTTED TO ASSURE THAT SATURATION PERCENTAGE LEVELS WERE ACCURATE.
5. ALL ALMEN STRIPS WERE MEASURED BEFORE AND AFTER PEENING WITH +/- .0005A ALMEN TOLERANCE UTILIZED ON NEW TEST STRIPS.
6. ALL PEENING MEDIA VELOCITIES WERE MEASURED BY PSI OF AIR PRESSURE. +/- 5% ON A 3/8" PRESSURE NOZZLE OR A 3/8" SUCTION NOZZLE AS REQUIRED AND HELD WITHIN WEAR TOLERANCES SPECIFIED IN AIRTECH PRECISION SHOT PEENING, INC. QUALITY ASSURANCE MANUAL.
7. EACH 50 POUND GLASS BEAD LOT WAS SAMPLED FOR SIZE AND CONCENTRICITY AND OTHER CONFORMANCE TO MIL-G-9954A.
8. BEFORE EACH DAY OF OPERATION ALL NOZZLE SIZES, NOZZLE MOTIONS, AIR PRESSURES, TIME CYCLES, AND PART ROTATION WERE CALIBRATED USING STANDARDS TRACEABLE TO THE NATIONAL BUREAU OF STANDARDS.
9. MATERIAL AND TEMPER DESIGNATIONS WERE VIBRO ETCHED INTO THE END OF EACH SPECIMEN BY SPIN MANUFACTURING DIRECTLY AFTER MANUFACTURING.
10. TEST GROUP DESIGNATION AND NUMBER WERE VIBRO ETCHED INTO THE OTHER END BY METCUT RESEARCH ASSOCIATES, INC.
11. SPECIMENS WERE SEGREGATED BY TEST GROUP AND TEST NUMBER.
12. TEST GROUPS UTILIZED NO MORE THAN ONE TEST SPECIMEN FROM EACH MANUFACTURING GROUP.

## 2.5 FATIGUE TESTING

1. FATIGUE TESTING WAS ACCOMPLISHED USING AN MTS 810 HYDRAULIC HIGH CYCLE AXIAL FATIGUE TEST MACHINE.
2. BASE LINE LOADING AMPLITUDE AND CONTROL GROUP DATA WERE ESTABLISHED BY DESTRUCTIVE TESTING FOUR (4) UNPEENED 7075-T6 AND SIX (6) UNPEENED 7075-T73 SPECIMENS.
3. MAXIMUM STRESS WAS 45 KSI FOR 7075-T73 AND 50 KSI FOR 7075-T6 AT A FREQUENCY OF 60 HZ, WITH LOAD RATIO, R, OF 0.1.
4. FATIGUE TESTING WAS PERFORMED BY METCUT ASSOCIATES, INC., OF CINCINNATI, OHIO.

## 2.6 POST TEST SPECIMEN EXAMINATION

1. SCANNING ELECTRON MICROSCOPY AND METALLOGRAPHY WERE UTILIZED TO EXAMINE BOTH THE TOPOGRAPHY OF THE PEENED SURFACES AND FRACTURE ORIGIN SITES. SINCE ALL SPECIMENS COULD NOT BE EXAMINED POST-DESTRUCTIVELY, IT WAS DECIDED BY AIRTECH THAT THE DESIRE OF ANY ONE MEMBER OF THE FOLLOWING GROUP OF THREE INVESTIGATORS, DR. JOHN CAMMETT, VICE-PRESIDENT MATERIALS METCUT RESEARCH; LUCIANO GATTO, MANAGER METALLOGRAPHY AND FRACTURE ANALYSIS, METCUT RESEARCH; AND ROGER SIMPSON, PRESIDENT, AIRTECH PRECISION SHOT PEENING, INC., CONSTITUTED NEED FOR EXAMINATION OF A PARTICULAR SPECIMEN.
2. SCANNING ELECTRON MICROSCOPY AND METALLOGRAPHY WERE PERFORMED BY METCUT RESEARCH ASSOCIATES, INC., OF CINCINNATI, OHIO.

### 3.0 STATISTICAL OVERVIEW

THE STATISTICAL ANALYSIS INVOLVED THE ESTABLISHMENT OF CORRELATION COEFFICIENTS BETWEEN THE VARIOUS INDEPENDENT AND DEPENDENT VARIABLES OF THIS STUDY. EACH SET OF DATA WAS ENTERED INTO EACH OF THE FOLLOWING REGRESSION FORMULAS:

LINEAR --	$y = a + bx$
QUADRATIC---	$y = a + bx + cx^2$
EXPONENTIAL --	$y = ae^{bx}$
POWER --	$y = ax^b$
HYPERBOLIC --	$y = a + \frac{bx}{-1}$
--	$y = \frac{(a + bx)^{-1}}$
--	$y = \frac{x}{(a + bx)^{-1}}$
LOGARITHMIC--	$y = a + b \log x$

IN ANALYZING MORE THAN ONE INDEPENDENT VARIABLE (SUCH AS INTENSITY AND MEDIA SIZE VERSUS FATIGUE LIFE) MULTIPLE LINEAR REGRESSION WAS USED. THE SOFTWARE UTILIZED PROVIDED MULTIPLE R-VALUES AS WELL AS PAIR-WISE CORRELATION COEFFICIENTS AND THE APPROPRIATE REGRESSION EQUATION.

NUMERICAL INDICES (IN THE FORM OF CORRELATION COEFFICIENTS AND EXPLAINED VARIANCES) WERE ESTABLISHED AMONG THE FOUR VARIABLES AFFECTING FATIGUE LIFE. IN EACH TWO-VARIABLE COMPARISON, THE DATA WERE ENTERED INTO EACH OF THE EIGHT POSSIBLE MATHEMATICAL MODELS. WHENEVER BASELINE (NON-PEENED) DATA WERE PRESENT SOME OF THE EQUATIONS WOULD NOT ACCEPT ZERO VALUES AND HAD TO BE IGNORED. THE GOAL WAS TO FIND A MODEL THAT BEST FIT THE OBSERVED DATA AS DETERMINED BY THE GREATEST AMOUNT OF DEPENDENT VARIABLE VARIANCE EXPLAINED.

#### 4.0 PRESENTATION OF RESULTS AND ANALYSIS

THE VARIABLES IN THE REGRESSION EQUATIONS ARE DESIGNATED AS FOLLOWS:

N = FATIGUE LIFE  
I = ALMEN INTENSITY  
S = SECONDARY FAILURE SITES  
D = PSEF DEPTH  
M = MEDIA SIZE

IN 7075-T6, THE ALMEN INTENSITY WAS CORRELATED WITH FATIGUE LIFE. THE FIRST CORRELATION COMPARED ALL INTENSITIES FROM 0A TO 20A (60 DATA POINTS) LINEAR REGRESSION PRODUCED CORRELATION COEFFICIENT OF ONLY .30, WHILE QUADRATIC RAISED THIS TO .54. THE OTHER EQUATIONS FAILED TO PRODUCE STATISTICALLY SIGNIFICANT RELATIONSHIPS.

A DUAL RELATIONSHIP WAS THEN SELECTED TO BEST DESCRIBE THE DATA. FROM 0A TO 5A, A QUADRATIC (PARABOLIC) RELATIONSHIP PRODUCED A GOOD STATISTICALLY SIGNIFICANT FIT WITH A CORRELATION COEFFICIENT OF .78, EXPLAINING 60% OF THE VARIANCE IN FATIGUE LIFE. THE EQUATION :

$$N = 314 + 280I - 45I^2$$

(\* SEE FIGURE #1, PAGE 12)

FROM 5A TO 20, A SECOND QUADRATIC EQUATION ( $N=539-16I-I^2$ ) PRODUCED .75 CORRELATION BUT IMPLIED A PARABOLA WHICH WAS CONCAVE DOWNWARD PEAKING AT A PEENING INTENSITY OF 8A. SINCE THIS WOULD SUGGEST AN INCREASE IN FATIGUE LIFE AT INTENSITIES HIGHER THAN THOSE TESTED AND CONTRADICTED THE OVERALL APPEARANCE OF THE DATA OBSERVED, THE SECOND BEST FIT (LINEAR) WAS USED WHICH PRODUCED A .69 CORRELATION (ALSO STATISTICALLY SIGNIFICANT) AND EXPLAINED 48% OF THE VARIANCE IN FATIGUE LIFE BETWEEN 5A AND 20A. THE EQUATION:

$$N = 704 - 17I$$

(\* SEE FIGURE #1, PAGE 12)

IN T73, TWENTY FOUR POINTS WERE USED TO CONSTRUCT A REGRESSION EQUATION RELATING ALMEN INTENSITY AND FATIGUE LIFE. THE FIRST CORRELATION COMPARED ALL INTENSITIES FROM 0A-20A. QUADRATIC REGRESSION PRODUCED THE BEST STATISTICAL FIT WITH COEFFICIENT OF .88, EXPLAINING 78% OF THE VARIANCE IN FATIGUE LIFE. WHILE BEING STATISTICALLY SIGNIFICANT, THIS REGRESSION FAILED TO EXPLAIN THE TRENDS IN THE OBSERVED DATA, SO, AS IN T6, A COMPOSITE REGRESSION CURVE WAS CONSTRUCTED. FROM 0A TO 7A, A PARABOLA OPENING DOWN PRODUCED THE BEST FIT WITH A STATISTICALLY SIGNIFICANT CORRELATION COEFFICIENT OF .89 EXPLAINING 80% OF THE VARIANCE IN FATIGUE LIFE. THE EQUATION:

$$N = 461 + 1731I - 258I^2$$

(\* SEE FIGURE #2, PAGE 14)

FROM 7A TO 20A A STRAIGHT LINE PROVIDED A GOOD FIT, DESPITE ITS NON-SIGNIFICANT CORRELATION COEFFICIENT OF .26. THE SMALL NUMBER (17) OF DATA POINTS CONTRIBUTED TO THIS LOW VALUE. THE EQUATION:

$$N = 681 - 27I$$

ALL OTHER REGRESSION EQUATIONS HAD LOWER CORRELATION COEFFICIENTS EXCEPT FOR THE QUADRATIC (PARABOLA OPENING UPWARD) WHICH CONTRADICTED THE OBSERVED DATA.

(\* SEE FIGURE #2, PAGE 14)

TABLE 2

SUMMARY OF FATIGUE LIFE DATA  
 7075-T6, ROOM TEMPERATURE  
 50 KSI MAX. STRESS, R = 0.1 (AXIAL)

TEST GROUP	ALMEN INTENSITY	FATIGUE LIFE: N (X 10 <sup>3</sup> CYCLES)		
		1	2	3
A	1A	628, 702	654, 612	649, 729, 577
B	3A	777, 847, 795	632, 670, 716	633, 569, 607
C	5A	691, 699, 553	601, 639, 653	616, 338, 584
D	7A	470, 591, 527	-----	582, 573, 616
E	9A	551, 597, 622	606, 533, 574	567, 460, 509
F	11A	477, 609	592, 555	575, 535, 504
G	13A	538, 566, 466	-----	-----
H	15A	516, 454, 498	-----	-----
Z	20A	-----	-----	406, 261, 193
Q	3A (200%)	590, 590	-----	-----
R	3A (300%)	620, 671	-----	-----
BASELINE	-----	111,359,154,252	-----	-----

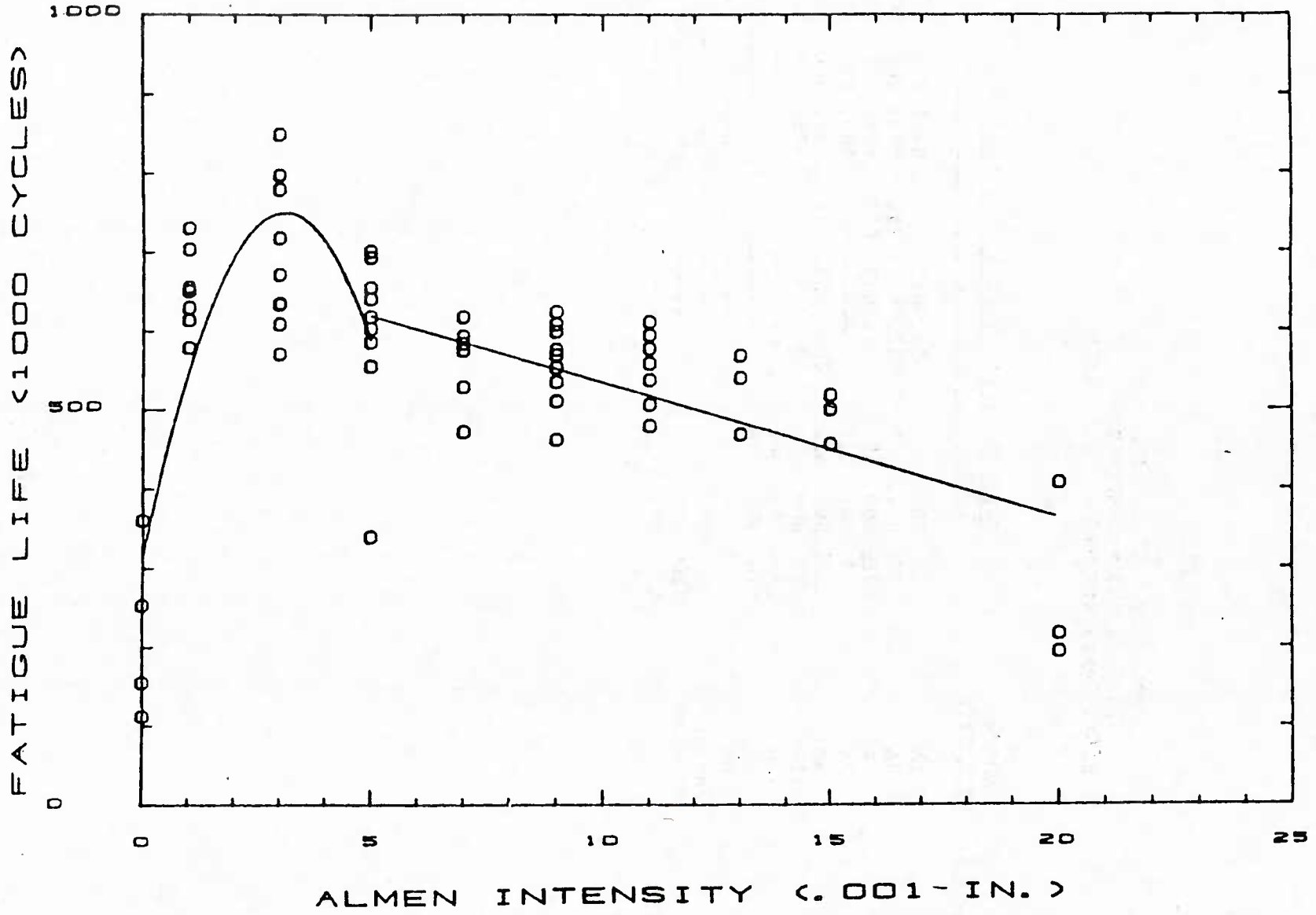

Figure 1 FATIGUE LIFE VS. ALMEN INTENSITY  
7075-T6 ALUMINUM ALLOY

TABLE 3

SUMMARY OF FATIGUE LIFE DATA  
 7075-T73, ROOM TEMPERATURE  
 45 KSI MAX. STRESS, R = 0.1 (AXIAL)

<u>TEST GROUP</u>	<u>ALMEN INTENSITY</u>	<u>FATIGUE LIFE (10<sup>3</sup> CYCLES)</u>
I	1A	3325
J	3A	3742*
K	5A	2016*, 2024*
L	7A	209, 286
M	9A	208, 1932*
N	11A	198, 167, 230
O	13A	214, 185, 257
P	15A	239, 196, 229
S	17A	159, 281
T	20A	220, 235
U	20A (200%)	268, 520
BASELINE	---	82, 45, 210

\* TEST TERMINATED; SPECIMEN DID NOT FAIL.

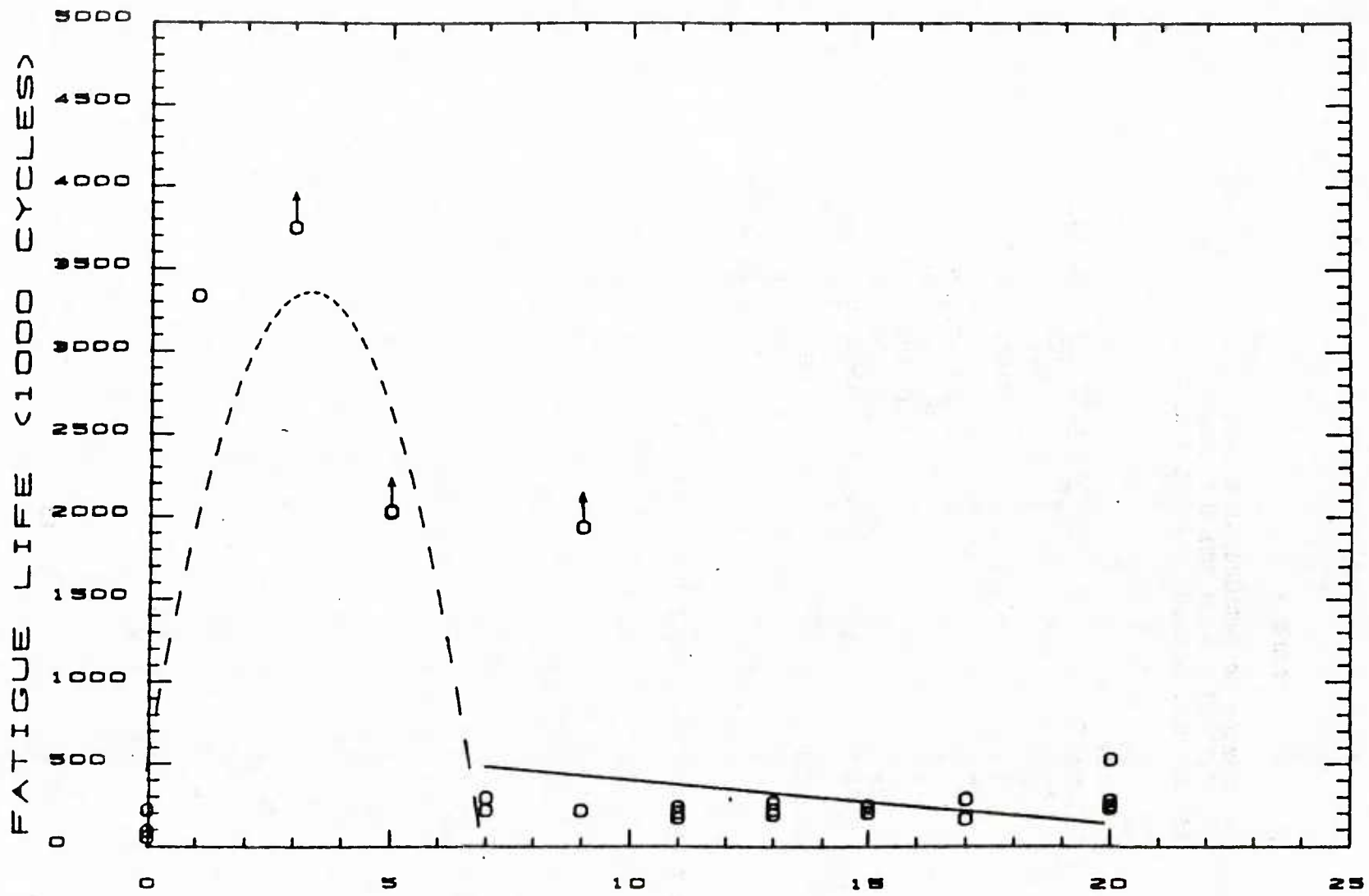

ALMEN INTENSITY (.001 IN.)

FIGURE 2 FATIGUE LIFE VS. ALMEN INTENSITY  
7075-T73 ALUMINUM ALLOY

IN T6, ALMEN INTENSITY WAS COMPARED WITH THE NUMBER OF SECONDARY FAILURE SITES AT NINE POINTS. A STATISTICALLY SIGNIFICANT LINEAR CORRELATION OF .72 RESULTED, EXPLAINING 52% OF THE VARIANCE. THE RESULTING REGRESSION EQUATION WAS:

$$S = .55I - 1.74$$

POWER REGRESSION AND LOGARITHMIC REGRESSION PRODUCED EXPLAINED VARIANCES OF 45% AND 55% RESPECTIVELY.

TABLE 4

NO. SEC. FAILURE SITES vs ALMEN INTENSITY  
7075-T6 ALUMINUM ALLOY

<u>INTENSITY</u>	<u>NUMBER OF SECONDARY FAILURE SITES</u>
3	0
5	0,2
7	0
9	0
11	3,8,9
20	7

(\* SEE FIGURE #3, PAGE 17)

IN T6 THERE WERE SEVEN AVAILABLE POINTS FOR BUILDING A CORRELATION BETWEEN ALMEN INTENSITY AND PSEF DEPTH. THE RESULTING STATISTICALLY SIGNIFICANT LINEAR COEFFICIENT OF .81 EXPLAINED 66% OF THE PSEF VARIABILITY. THE REGRESSION EQUATION WAS:

$$D = 11.43 + 1.33I$$

ALL OTHER REGRESSION FORMULAS GAVE LOWER EXPLAINED VARIABILITIES: EXPONENTIAL (61%), POWER (64%), HYPERBOLIC (56%), LOGARITHMIC (65%)

TABLE 5  
PSEF DEPTH vs ALMEN INTENSITY  
7075-T6 ALUMINUM ALLOY

<u>INTENSITY</u>	<u>OBSERVED PSEF DEPTH</u>
3	.0028
5	.0040
7	.0028
9	.0064
11	.0042
13	.0060
15	.0074

(SEE FIGURE #4, PAGE 18)

IN T73, THERE WERE ONLY 4 AVAILABLE COMPARISONS BETWEEN INTENSITY AND PSEF DEPTH. AS SUCH THOUGH, THE CORRELATION WAS .79, EXPLAINED 63% OF THE VARIABILITY IN DEPTH, AND WAS NOT STATISTICALLY SIGNIFICANT. THE EQUATION:

$$D = 22 + .34I$$

NO OTHER REGRESSIONS PRODUCED HIGHER EXPLAINED VARIANCES:  
EXPONENTIAL (63%), POWER (51%), HYPERBOLIC (62%), LOGARITHMIC (52%)

TABLE 6

PSEF DEPTH vs ALMEN INTENSITY  
7075-T73 ALUMINUM ALLOY

<u>INTENSITY</u>	<u>OBSERVED PSEF DEPTH</u>
1	0
7	.0050
11	.0052
15	.0050
20	.0060

(\* SEE FIGURE #5, PAGE 19)

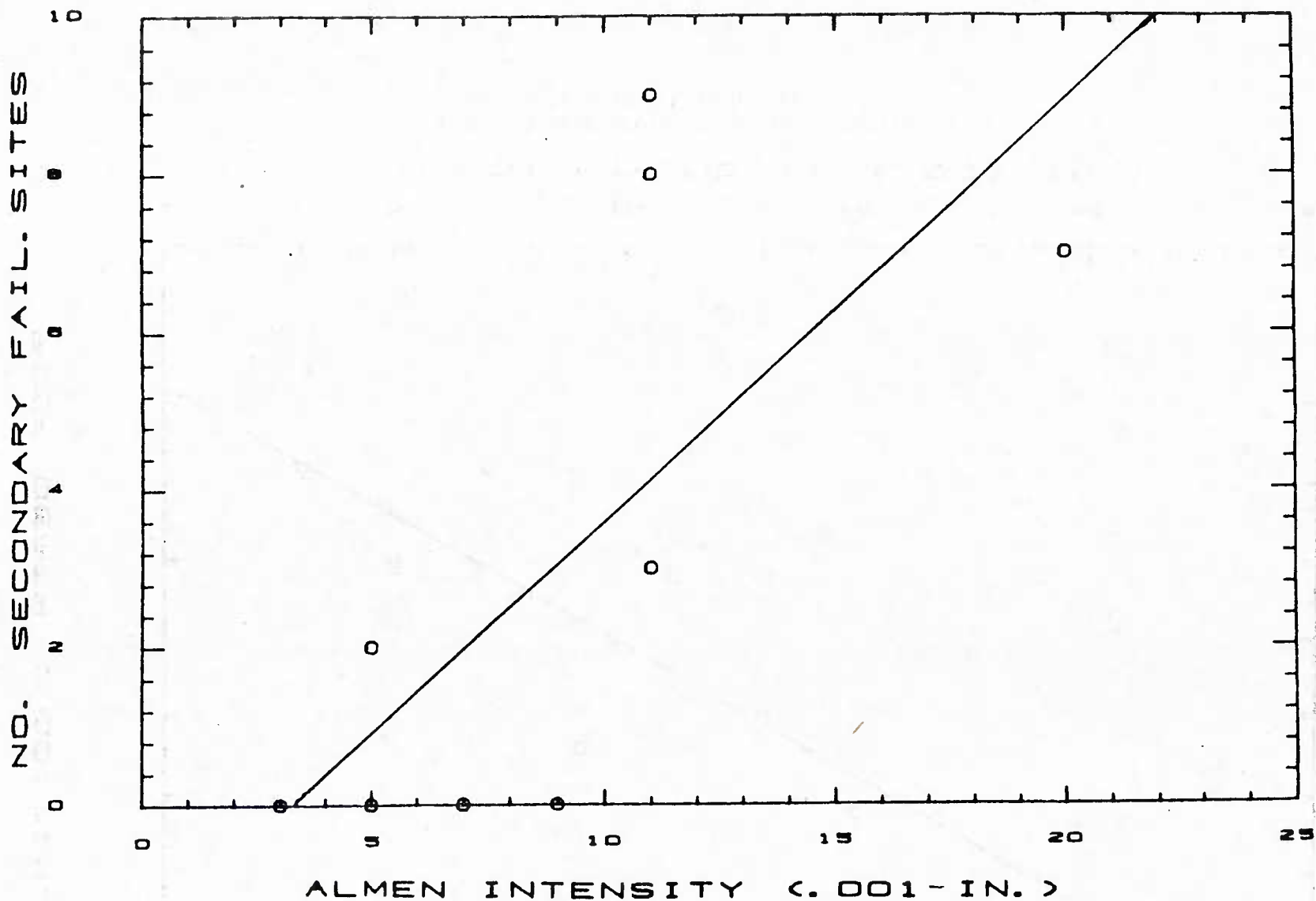

FIGURE 3 NO. SEC. FAIL. SITES VS. ALMEN INTENSITY  
7075-T6 ALUMINUM ALLOY

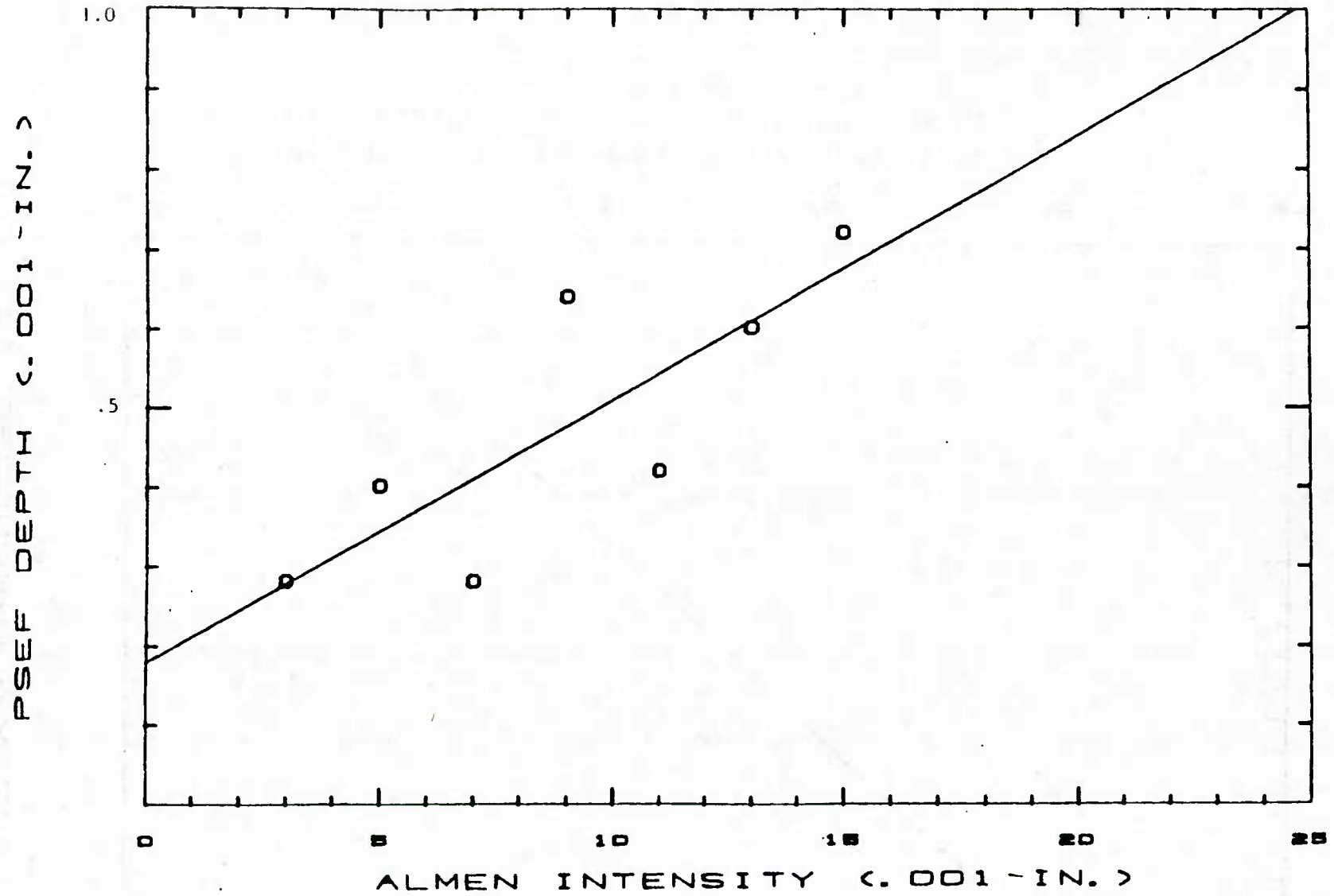

FIGURE 3 PSEF DEPTH VS. ALMEN INTENSITY  
7075-T6 ALUMINUM ALLOY

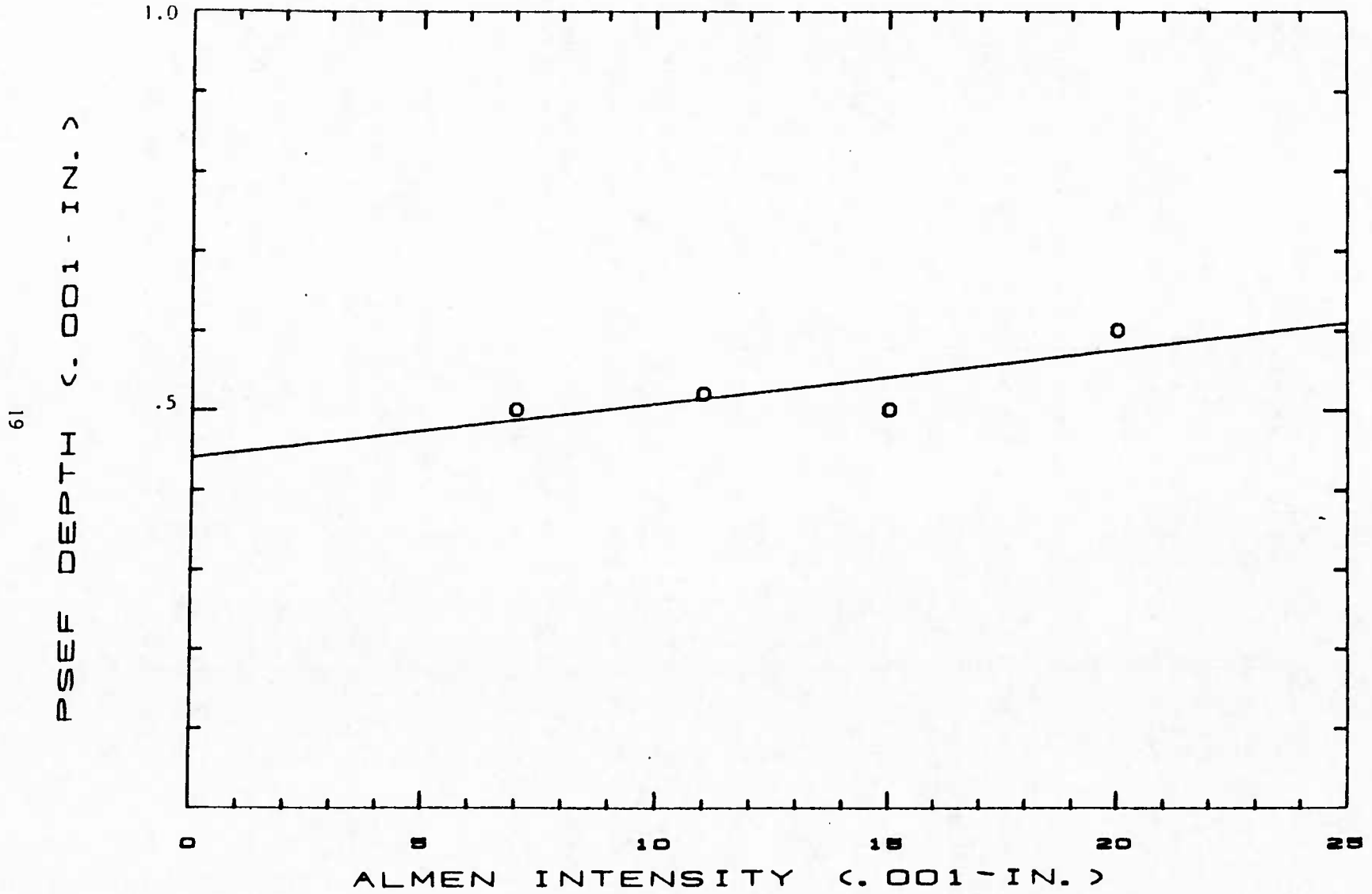

FIGURE 5 PSEF DEPTH VS. ALMEN INTENSITY  
7075-T73 ALUMINUM ALLOY

SEVEN COMPARISONS IN T6 WERE MADE BETWEEN PSEF DEPTH AND FATIGUE LIFE AND RESULTED IN NO STATISTICALLY SIGNIFICANT CORRELATION. IN T73, FOUR COMPARISONS ALSO RESULTED IN NO SIGNIFICANT CORRELATIONS.

WHEN PSEF DEPTH IN T6 WAS COMPARED WITH THE NUMBER OF SECONDARY FAILURE SITES, A HYPERBOLIC CORRELATION OF .58 RESULTED (S=7) WHICH, HOWEVER, IS NOT STATISTICALLY SIGNIFICANT AT THE .05 LEVEL FOR 6 DEGREES OF FREEDOM. IN T73, THE FOUR POINTS PRODUCED .18 HYPERBOLIC CORRELATION, ALSO NON-SIGNIFICANT.

SATURATION AND MEDIA SIZE WERE CORRELATED AGAINST THE FATIGUE LIFE OF THE 13 OBSERVATIONS USING 3A INTENSITY WITH T6. A STATISTICALLY SIGNIFICANT MULTIPLE CORRELATION OF  $R = .78$  RESULTED WITH 61% EXPLAINED VARIANCE. ALONE, SATURATION EXPLAINED 20% ( $r = .44$ ) AND MEDIA SIZE EXPLAINED 10% ( $r = .32$ ) WHILE SATURATION CORRELATED WITH MEDIA SIZE AT  $-.32$  FOR THESE 13 T6 ITEMS PEENED AT 3A. NONE OF THESE INTER-CORRELATIONS WERE STATISTICALLY SIGNIFICANT.

OVERALL, SATURATION AND INTENSITY (100% AND 200% USING 20A ON T73 AND 100%, 200%, AND 300% USING 3A ON T6) CORRELATED SIGNIFICANTLY AT .87 (EXPLAINED VARIANCE = 72%). HOWEVER, THIS WAS THE RESULT OF THE HIGH CORRELATION ( $-.84$ ) BETWEEN THE INTENSITY AND FATIGUE LIFE OF THESE 18 OBSERVATIONS.

OBSERVING ONLY THE 3A INTENSITY WORKING ON T6 AND IGNORING MEDIA SIZE, SATURATION CORRELATES AGAINST FATIGUE LIFE AT  $-.32$ , EXPLAINING ONLY 10% OF THE VARIANCE.

MULTIPLE LINEAR REGRESSION WAS USED TO COMPARE ALMEN INTENSITY, MEDIA SIZE AND FATIGUE LIFE OF T6. ALL 60 OBSERVATIONS FROM 0A THROUGH 20A PRODUCED A MULTIPLE R OF .30 WHICH EXPLAINED ONLY 9% OF THE VARIANCE IN FATIGUE LIFE.

REMOVING THE BASE-LINE (0A) DATA, THE REMAINING 56 OBSERVATIONS RAISED THE R VALUE SIGNIFICANTLY TO .77 (60% EXPLAINED VARIANCE). THE RESULTING REGRESSION EQUATION HAS A STANDARD ERROR OF ESTIMATE OF 74.

$$N = 577 - 12I + 20M$$

INTENSITY EXPLAINED 54% OF THE VARIANCE AND MEDIA SIZE EXPLAINED 40%.

INTENSITY CORRELATED SIGNIFICANTLY WITH MEDIA SIZE AT  $-.60$  AND WITH FATIGUE LIFE AT  $-.73$  WHILE MEDIA SIZE CORRELATED WITH FATIGUE LIFE AT  $+.63$ . ALL THREE CORRELATIONS ARE STATISTICALLY SIGNIFICANT.

EXAMINING THE LOWER INTENSITIES (0A-3A) PRODUCED A SIGNIFICANT MULTIPLE  $R = .69$  (48% EXPLAINED VARIANCE). INTENSITY ( $r = .69$ ) EXPLAINED 48% AND MEDIA SIZE ( $r = .26$ ) EXPLAINED 7% WHILE THE TWO INDEPENDENT VARIABLES CORRELATED AT  $-.28$ . FINALLY THE HIGHER INTENSITIES WERE EXAMINED (5A - 20A). THE MULTIPLE  $R = .70$  IMPLIED AN EXPLAINED VARIANCE OF 48%. INTENSITY ( $r = .69$ ) EXPLAINED 47%, MEDIA SIZE ( $r = .49$ ) EXPLAINED 24%, WHILE INTENSITY AND MEDIA SIZE INTER-CORRELATED AT  $.49$ .

MEDIA SIZE CORRELATED SIGNIFICANTLY (n = 44) WITH FATIGUE LIFE IN T6 AT THE .64 LEVEL AND EXPLAINED 42% OF THE VARIANCE IN FATIGUE LIFE. THE REGRESSION EQUATION FOR PREDICTING FATIGUE LIFE BASED ON MEDIA SIZE IS:

$$N = 440M + 33$$

AND GIVES THE FOLLOWING RESULTS:

ALL OTHER REGRESSIONS EXPLAINED A LOWER AMOUNT OF VARIANCE: EXPONENTIAL (36%), POWER (35%), HYPERBOLIC (36%), LOGARITHMIC (39%)

(\* SEE FIGURE #6, PAGE 22)

IN T73 THERE WERE A TOTAL OF 11 SURFACE FRACTURES AND 6 INTERIOR FRACTURES (DEEPER THAN THE PLASTICALLY DEFORMED LAYER). THE THREE BASELINE TESTS WITHOUT PEENING, PRODUCED 3 SURFACE FRACTURES.

IN T6 THERE WERE 48 INTERIOR AND 11 SURFACE FRACTURES WITH PEENING, PLUS 4 SURFACE FRACTURES WITHOUT PEENING.

AS PSEF INCREASES, WHAT IS THE EFFECT ON CRACK NUCLEATION LOCATION? THE FOLLOWING TABLES TALLY THE DATA.

TABLE 7

CRACK NUCLEATION LOCATION 7075-T73 ALUMINUM ALLOY  
100% SATURATION

<u>ALMEN</u> <u>INTENSITY</u>	<u>#PSEF</u> <u>PRESENT</u>	<u>CRACK NUCLEATION</u> <u>LOCATION</u>		<u>TOTAL FAILED</u> <u>SPECIMENS</u>	<u>TOTAL SPEC.</u> <u>TESTS</u>
		<u># SURF.</u> <u>FRACTURES</u>	<u># INTER.</u> <u>FRACTURES</u>		
0A	0	3	0	3	3
1A	0	0	1	1	1
3A	0	0	0	0	1
5A	0	0	0	0	2
7A	11	2	0	2	2
9A	0	1	0	1	2
11A	20	3	0	3	3
13A	0	1	2	3	3
15A	12	2	1	3	3
17A	0	0	2	2	2
20A	10	2	0	2	2
TOTALS	53	14	6		

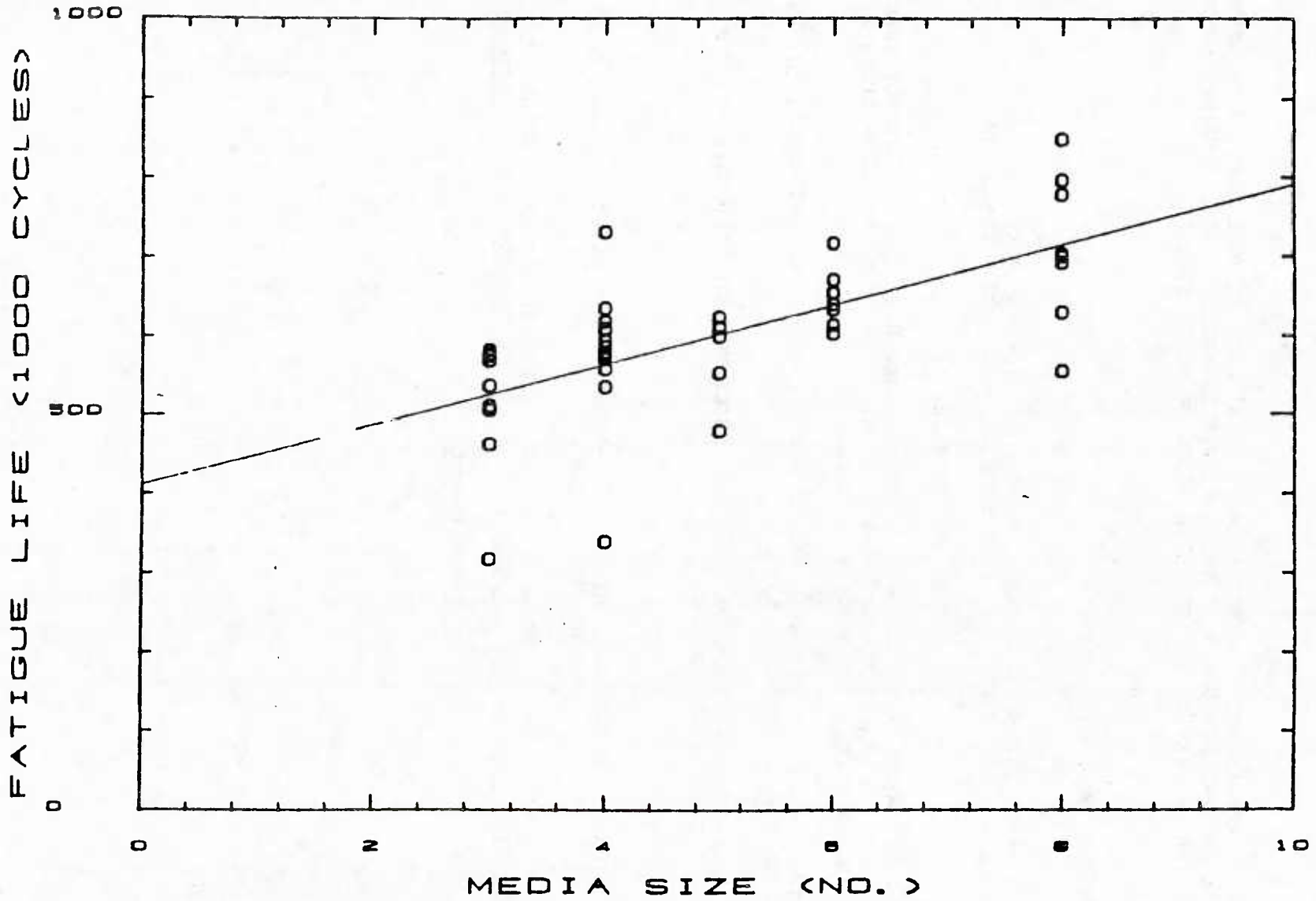

FIGURE 6 MEDIA SIZE VS. FATIGUE LIFE  
7075-T6 ALUMINUM ALLOY

E

E

TABLE 8

CRACK NUCLEATION LOCATION 7075-T6 ALLUMINUM ALLOY  
100% SATURATION

<u>ALMEN INTENSITY</u>	<u>#PSEF PRESENT</u>	<u>CRACK NUCLEATION LOCATION</u>		<u>TOTAL FAILED SPECIMENS</u>	<u>TOTAL SPEC. TESTS</u>
		<u># SURF. FRACTURES</u>	<u># INTER. FRACTURES</u>		
0A	0	4	0	4	4
1A	0	2	6	8	8
3A	16	1	8	9	9
5A	8	3	6	9	9
7A	6	0	6	6	6
9A	6	1	8	9	9
11A	9	2	7	9	9
13A	0	0	3	3	3
15A	0	0	3	3	3
17A	0	0	0		
20A	9	2	1	3	3
TOTALS	54	15	48		

ANALYSIS OF THE DATA REVEALED THAT ALMEN INTENSITY CORRELATED WELL WITH THE FOLLOWING FAILURE LOCATIONS.

TABLE 9

## ALMEN INTENSITY vs FAILURE LOCATION

<u>METAL</u>	<u>INTENSITY</u>	<u>LOCATION</u>	<u>CORR. COEFF.</u>
T6	1-20	I	-.83
T6	0-3	I	+.89
T6	3-20	I	-.87
T6	0-3	S	-.76
T73	0-3	S	-.76

THE NUMBER OF PSEF CORRELATED WELL WITH FAILURE LOCATIONS AS FOLLOWS:

TABLE 10

## PSEF vs FAILURE LOCATION

<u>METAL</u>	<u>INTENSITY</u>	<u>LOCATION</u>	<u>CORR. COEFF.</u>
T6	0-3	I	+.69
T73	3-20	S	+.93
T6	3-20	I	+.62

THUS, IT APPEARS THAT ALTHOUGH ALMEN INTENSITY CORRELATES WELL WITH FAILURE LOCATION, (ESPECIALLY THE NUMBER OF T6 INTERIORS), THE NUMBER OF PSEFS CORRELATE ONLY WITH T73 SURFACE FAILURES WHEN INTENSITY IS GREATER THAN OR EQUAL TO 3A.

## 5.0 DISCUSSION

SHOT PEENING, AS HYPOTHESIZED, IS LINKED TO A PHENOMENON WE CALL PEENED SURFACE EXTRUSION FOLDS (PSEF), WHICH ARE LAPS IN THE SURFACE MATERIAL SHOT PEENED AT INTENSITIES HIGHER THAN THOSE CORRELATING WITH OPTIMUM FATIGUE LIFE. THE INCREASE, PEAK, AND DECREASE OF WORKPIECE FATIGUE LIFE AS SHOT PEENING INTENSITY INCREASED WAS FIRST DOCUMENTED BY ALMEN IN 1943. (REF. #23) THERE HAS BEEN, HOWEVER, NO EXPLANATION OF PHENOMENA CAUSAL TO THE DECREASE OF FATIGUE LIFE AS INTENSITY ROSE ABOVE THE LEVELS CORRELATING WITH OPTIMUM FATIGUE LIFE. THE DATA GENERATED IN THIS STUDY INDICATES THAT THERE IS A STRONG RELATIONSHIP BETWEEN PSEF, NUMBER OF SECONDARY SURFACE CRACKS AT THE TIME OF FAILURE, FATIGUE LIFE, AND INCREASING INTENSITY ABOVE THE INTENSITY CORRELATING WITH OPTIMUM FATIGUE LIFE. OUR THEORY THAT SHOT PEENING INTENSITY WAS POSITIVELY CORRELATED WITH FATIGUE LIFE UNTIL REACHING AN UNDETERMINED INTENSITY, AND WAS NEGATIVELY CORRELATED WITH FATIGUE LIFE ABOVE THAT LEVEL IS SUPPORTED BY THE DATA.

THERE ARE TWO DISTINCT STATISTICAL PATTERNS IN THE DATA CONCERNING FATIGUE LIFE vs INTENSITY FOR BOTH MATERIALS. THE FACT THAT THEY ARE THE SAME PATTERNS FOR BOTH DEMONSTRATES EVEN MORE VALIDITY IN THE RESULTS. THE RELATIONSHIP FROM 0A-5A (T-6) AND 0A-7A (T-73) HAS ITS STRONGEST STATISTICAL SIGNIFICANCE IN A QUADRATIC EQUATION (PAGES 9 AND 10). THE RELATIONSHIP FROM 5A (T6) AND 7A (T73) TO MAXIMUM INTENSITY HAS ITS DATA BEST DESCRIBED BY A LINEAR EQUATION (PAGES 9 AND 10). THE CORRELATION COEFFICIENTS OF THESE 4 PATTERNS ARE AS FOLLOWS: T6: 0A-5A=.78, 5A-20A=.69 T73: 0A-7A=.89, 7-20A=.26 THE SHARP CLIMB TO MAXIMUM FATIGUE LIFE (3A) FOR BOTH MATERIALS, THE RELATIVELY (BY INDUSTRY STANDARDS) NARROW RANGE OF OPTIMUM FATIGUE LIFE, AND THE SHARP DECLINE OF FATIGUE LIFE WAS MORE DRAMATIC THAN EVEN THE AUTHORS EXPECTED. AT INTENSITIES ABOVE THE END OF THE QUADRATIC PATTERN (5A-20A: T6, 7A-20A: T73), THERE IS A GRADUAL DECLINE IN FATIGUE LIFE (FIGURES 1 AND 2).

IN THE 7075-T73 HARDNESS CONDITION, PRIMARY CRACK NUCLEATION OCCURED AT THE SURFACE IN UNPEENED SPECIMENS AND SPECIMENS PEENED WITH INTENSITIES ABOVE THOSE ASSOCIATED WITH OPTIMUM FATIGUE LIFE (TABLE 7). THE PERCENTAGE OF FATIGUE LIFE INCREASE FROM UNPEENED WAS 3341% AT 3A INTENSITY AND DEGRADED RAPIDLY FROM THIS POINT. AT 5A INTENSITY, THE PRECENTAGE OF FATIGUE LIFE INCREASE FROM UNPEENED WAS 1800% OR 54% OF 3A; AND AT 7A, IT WAS 221% OF UNPEENED AND 7% OF 3A. T-6 SPECIMENS PEENED AT INTENSITIES 5A TO 17A FAILED FROM PRIMARY CRACKS WITH INTERIOR NUCLEATION SITES. THERE WAS, HOWEVER, A SIGNIFICANT AND CONSISTENT DETERIORATION IN FATIGUE LIFE AS INTENSITY ROSE IN THIS RANGE. THE GENERAL DEGRADATION OF FATIGUE LIFE AFTER THE OPTIMUM INTENSITY OF 3A IN INTENSITIES RESULTING IN INTERIOR PRIMARY CRACK NUCLEATION IS ACCOMPANIED BY A SIGNIFICANT INCREASE IN SECONDARY CRACKS NUCLEATING AT THE SURFACE. SECONDARY CRACKS BECOME GREATER IN QUANTITY AND DEPTH AS INTENSITY (FIGURE 3), AND SUBSEQUENTLY, PSEF DEPTH AND QUANTITY INCREASE (FIGURES 4 AND 5). IMPORTANTLY, THE INCREASES IN SURFACE SECONDARY CRACK NUCLEATION SITES AS INTENSITY ROSE AND FATIGUE LIFE DROPPED REPRESENT THE EFFECTS OF A STEADILY DECREASING NUMBER OF LOADING CYCLES. AT 20A ALL T-6 SPECIMENS FAILED FROM EXTERIOR CRACK NUCLEATION SITES.

IT IS THE THEORY OF THE AUTHORS THAT IN 7075-T6 PEENING INTENSITIES ABOVE 3A WHERE INTERIOR PRIMARY CRACK NUCLEATION OCCURED, THE SECONDARY FAILURE CRACKS DEVELOPING ON THE SURFACE NUCLEATED AFTER THE PRIMARY CRACK AND PROPAGATED INWARD TO MEET THE PRIMARY CRACKS. THIS THEORY IS SUPPORTED BY THE FACT THAT SECONDARY CRACKS WERE FOUND TO BE NON-EXISTENT IN THE 1A AND 3A SPECIMENS EXAMINED AND SECONDARY CRACK DEPTH AND QUANTITY GENERALLY INCREASED AS INTENSITY ROSE. (ONE, 11A, 7075-T6 SPECIMEN EXAMINED HAD A TOTAL OF NINE SECONDARY CRACKS IN THE LENGTH OF SURFACE EXAMINED.) THE GENERAL, LOW MAGNITUDE INCREASE IN QUANTITY OF THESE SECONDARY FAILURE CRACKS AS INTENSITY ROSE IN THIS RANGE PARALLELS A GENERAL, LOW MAGNITUDE FATIGUE LIFE DEGRADATION IN 7075-T6 SPECIMENS FROM 3A UP AND TO AN INTENSITY WHERE PRIMARY FAILURE OCCURED ON THE SURFACE.

AS IN THE 7075-T6 CONDITION, THE FEATURE AT THE SITE OF PRIMARY CRACK NUCLEATION IS SOMETIMES OBLITERATED BY MECHANICAL DAMAGE FROM FAILURE OR BY POLISHING IN PREPARATION FOR METALLOGRAPHIC EXAMINATION. THERE IS, HOWEVER, A HIGH PERCENTAGE OF SURFACE CRACK NUCLEATION SITES WHOSE PRIMARY FEATURE IS A VOID ASSOCIATED WITH EMBEDDED GLASS PARTICLES OR PSEF. THIS SAME PHENOMENON IS TRUE IN T-6 SPECIMENS FOR SECONDARY CRACKS IN SPECIMENS PEENED AT 5A TO 17A.

THE OPTIMUM INTENSITY FOR BOTH HEAT TREAT CONDITIONS APPEARS THE SAME IN THE DATA. ACTUALLY, THE 3A AND 5A SPECIMENS WERE REMOVED FROM THE TEST STAND WHEN THEY HAD REACHED THE NUMBER OF CYCLES LISTED IN THE DATA. ANY CHANGE OF OPTIMUM INTENSITY FROM 3A TO 5A WOULD HAVE INDEED BEEN NOTEWORTHY, HOWEVER, DUE TO TEST PROGRAM COST CONSTRAINTS, PRESSING TIME REQUIREMENTS, THE LACK OF SIGNIFICANCE THAT SUCH A CHANGE WOULD HAVE ON DETERMINING THE PATTERN OF CHANGE DUE TO ONLY TWO MATERIAL HARDNESS CONDITIONS, AND THE SMALL EFFECT IT WOULD HAVE ON DEMONSTRATING THE VALIDITY OF A MODEL FOR PREDICITNG FATIGUE LIFE, THESE SPECIMENS WERE NOT RUN TO FAILURE.

TEST RESULTS INDICATE THAT EMBEDDED GLASS BEAD FRAGMENTS ARE AS DELETERIOUS TO FATIGUE LIFE AS PSEF. IN FACT, THEY BEAR A TECHNICAL SIMILARITY TO PSEF IN THAT THEY OCCUPY A SPACE FORMING A RELATIVELY DEEP VOID IN THE SURFACE.

BROKEN PARTICLE CONTENT HAS BEEN GENERALLY CONSIDERED FOR A NUMBER OF YEARS TO HAVE DELETERIOUS EFFECTS ON THE FATIGUE LIFE OF PEENED COMPONENTS, BUT HAS NOT, TO THE AUTHORS' KNOWLDEGE, BEEN LINKED IN AVAILABLE LITERATURE TO CRACK NUCLEATION SITES AT EMBEDDED PARTICLES. THE EXTREMELY TIGHT BROKEN PARTICLE CONTENT CONTROLS UTILIZED DURING OUR PHASE I PROCEDURES WOULD SEEM TO BE PROBLEMATIC FOR MOST PRODUCTION GLASS BEAD OPERATIONS, WHERE REQUIREMENTS FOR MAINTENANCE AND QUANTITATIVE MAXIMUM BROKEN PARTICLE CONTENT IN THE SHOT CHARGE ARE NORMALLY NOT AS STRINGENT.

THE CONSISTENT DEGRADATION OF FATIGUE LIFE AS PEENING MEDIA SIZE INCREASES MAY BE DUE, WE POSTULATE, TO ONE OR MORE OF THREE FACTORS.

1. THE FIRST IS RELATED TO BROKEN MEDIA AND EMBEDDED PARTICLES. SINCE A LARGER BEAD WILL TEND TO BREAK INTO RELATIVELY LARGER PIECES THAN SMALLER BEAD, A SUBSEQUENT EMBEDDED PARTICLE FROM LARGER MEDIA WOULD TEND TO BE LARGER IN SIZE, DEEPER IN SURFACE PENETRATION, AND HENCE, MORE LIKELY TO CAUSE CRACK NUCLEATION.
2. THE SECOND IS AN UNEVENNESS IN THE PLASTIC DEFORMATION LAYER NOTED IN SEVERAL METALLOGRAPHIC EXAMINATIONS. 100% SATURATION WILL, BY DEFINITION, BE THE FIRST INSTANT AT WHICH THE SURFACE IS ENTIRELY IMPINGED WITH OVERLAPPING IMPINGEMENTS GENERATED BY SHOT TRAVELING AT OPTIMUM VELOCITY AT THE OPTIMUM IMPACT ANGLE. AS SUCH THERE THEORETICALLY WOULD BE A TENDENCY FOR THE LAYER OF PLASTIC DEFORMATION AT 100% TO BE DIFFERENT BENEATH THE CENTER OF IMPINGEMENTS OVERLAP. THESE VARIATIONS OF THE PLASTICALLY DEFORMED LAYER IN PEENING WITH LARGER MEDIA SIZE MAY BE QUANTITATIVELY FEWER WITH A GREATER DIFFERENCE IN MAGNITUDE OF EACH VARIATION THAN IN SMALLER MEDIA. THIS THEORY IS ONLY SUPPORTED BY FACE VALIDITY; AND NO TEST DATA WAS EVALUATED TO DETERMINE CAUSALITY OF FATIGUE LIFE AND MEDIA SIZE CORRELATIONS.
3. THE TENDENCY OF A LARGER MEDIA TO LEAVE LARGER INDENTATIONS AND, HENCE, FOR THE MATERIAL ASSOCIATED WITH THE PERIPHERY OF THE INDENTATION TO BE DISPLACED A GREATER DISTANCE WOULD INDICATE A GREATER DEPTH AND NUMBER OF PSEF NEAR THIS PERIPHERY. THIS FACTOR WOULD NOT, HOWEVER, TAKE INTO ACCOUNT THE REDUCED FATIGUE LIFE AT INTENSITY LEVELS WHERE PSEF WERE NOT PRESENT.

THE STRESS CORROSION RESISTANCE TESTS UNDERTAKEN SHOW THAT FOR PURE STRESS CORROSION RESISTANCE (SPECIMENS SUBJECTED TO A STATIC LOAD IN A CORROSIVE ENVIRONMENT), BOTH THE OPTIMUM INTENSITY LEVEL (3A) FOR FATIGUE LIFE AND MUCH HIGHER INTENSITIES (20A) RESULTED IN SUBSTANTIAL INCREASES IN STRESS CORROSION RESISTANCE.

THERE ARE, HOWEVER, FEW REAL WORLD APPLICATIONS WHERE THIS TYPE OF PURE STATIC LOAD IS EXPERIENCED. MUCH MORE COMMON IN ACTUAL APPLICATION WHERE CORROSION RESISTANCE IS IMPORTANT IS LOW MAGNITUDE CYCLIC TENSILE LOADING. HENCE, THE QUESTION IS RAISED AS TO WHAT TYPE OF RESULTS CAN BE EXPECTED FROM CYCLIC LOADING OF PEENED ALUMINUM COMPONENTS AT SMALL FRACTIONS OF YIELD STRESS IN CORROSIVE ENVIRONMENTS.

SEVERAL POINTS ARE PERTINENT TO THIS DISCUSSION. THEY ARE AS FOLLOWS:

- A. STRESS CORROSION CRACKS ARE AN ENTIRELY SURFACE NUCLEATING PHENOMENON.
- B. 20A PEENED 7075-T6 AND 7075-T73 SPECIMENS HAVE A MUCH LOWER SURFACE FRACTURE RESISTANCE THAN 3A WHEN EXPOSED TO CYCLIC LOADING IN NON-CORROSIVE ENVIRONMENTS.
- C. 20A SPECIMENS SHOW PSEF AND EMBEDDED PEENING MEDIA FRAGMENTS WHICH ARE LARGE PERCENTAGES OF THE PLASTICALLY DEFORMED LAYER IN DEPTH.

IT HAS BEEN SUGGESTED BY SOME THAT HIGHER PEENING INTENSITIES IN 7075 WOULD BE MORE EFFECTIVE AT STRESS CORROSION RESISTANCE THAN LOWER INTENSITIES, EVEN THOUGH LOWER INTENSITIES WOULD HAVE A GREATER RESISTANCE TO CRACK NUCLEATION. A CURSORY STUDY OF FRACTURE MECHANICS AS IS APPLICABLE IN LOW STRESS LEVEL FATIGUE CORROSION, HOWEVER, WOULD INDICATE THAT THIS ASSUMPTION HAS AT THE VERY LEAST SOME SERIOUS QUESTIONS WHICH REMAIN UNANSWERED. AS A CRACK NUCLEATES IN EITHER A CORROSIVE OR NON-CORROSIVE ENVIRONMENT, IT CONCURRENTLY BECOMES AN AREA OF STRESS CONCENTRATION. SINCE THE ACTUAL STRESS AT THE CRACK TIP WILL BE MUCH HIGHER (IN KSI) THAN THE APPLIED STRESS ON THE PART, THE EXTENDED DEPTH OF COMPRESSION WILL BE OF QUESTIONABLE CAPABILITY IN ELIMINATING CRACK PROPAGATION, AND MAY BE ONLY ACADEMIC. ADDITIONALLY, RESIDUAL STRESS PROFILES OF 18A AND 12N (APPROXIMATELY 4A) INDICATE THAT MAXIMUM COMPRESSION IN 12N IS SUBSTANTIALLY HIGHER THAN 18A. (SEE PAGES 38, 39). THE PERTINENCE THESE RESIDUAL STRESS PROFILES IS INCREASED WHEN CONSIDERING THE FACT THAT COLD WORK IN AND OF ITSELF WITHOUT THE BENEFITS OF COMPRESSION GENERALLY DECREASES STRESS CORROSION RESISTANCE. 18A, 200% SPECIMENS MEASURED FOR RESIDUAL STRESS ACTUALLY SHOWED MILD SURFACE RESIDUAL TENSILE LOADS. (SEE APPENDIX B, RESIDUAL STRESS PROFILES) TO DEFINITELY STATE THAT INTENSITIES CORRELATING WITH OPTIMUM FATIGUE LIFE NEED NOT BE CONSIDERED IN FATIGUE CORROSION WOULD REQUIRE A SUBSTANTIAL AMOUNT OF FATIGUE CORROSION TESTS AT THE PREDETERMINED WORKPIECE MAXIMUM STRESS LEVEL TO DETERMINE WHETHER THE STRESS CORROSION RESISTANCE RESULTS WOULD BE AS ADVANTAGEOUS AT HIGHER INTENSITIES AS AT OPTIMUM FATIGUE LIFE INTENSITY. NOT KNOWING THE EXACT MAXIMUM STRESS LEVEL IN ALL AREAS OF THE PART WOULD REQUIRE UTILIZATION OF THE INTENSITY CORRELATING WITH OPTIMUM FATIGUE LIFE SINCE IT WILL ALSO YIELD VERY HIGH INCREASES IN PURE STRESS CORROSION RESISTANCE. ADDITIONAL STUDIES IN THIS AREA ARE REQUIRED TO BETTER DEFINE THE FATIGUE/CORROSION INTERACTION ON PEENED COMPONENTS.

IT IS OF PARTICULAR IMPORTANCE THAT, ALTHOUGH THE INTENSITY LEVEL CORRELATING WITH OPTIMUM FATIGUE LIFE WAS THE SAME IN BOTH T-6 AND T-73, THIS INTENSITY IS IN DIRECT CONTRADICTION TO THE INTENSITY RANGE SPECIFIED IN MIL-STD-852 FOR ALUMINUM OF .375 SECTION PEENED WITH GLASS BEADS. THE INTENSITY LISTED IN MIL-S-13165B IS IN APPROXIMATE AGREEMENT WITH OUR DATA (8-12N OR APPROXIMATELY 2-3A). CLEARLY MANY PEENING SPECIFICATIONS, BOTH MILITARY AND INDUSTRIAL, NEED BETTER DEFINITION OF OPTIMUM PARAMETERS AND THE PROCESS CONTROLS NECESSARY TO MAINTAIN THOSE OPTIMUMS.

FROM OTHER DATA GENERATED AT AIRTECH PRECISION SHOT PEENING, INC. AND DATA THAT METCUT RESEARCH ASSOCIATES DEVELOPED IN WORK FOR AIR FORCE WRIGHT AERONAUTICAL LABS, A SIMILAR LACK OF AGREEMENT EXISTS BETWEEN RECENT TEST RESULTS AND APPLICABLE MIL-SPECS SPECIFIED PEENING INTENSITIES. THESE TESTS INCLUDE OTHER ALLOYS OF ALUMINUM AND OTHER RELATIVELY MALLEABLE MATERIALS SUCH AS TITANIUM. OTHER AIRTECH PRECISION SHOT PEENING, INC. TEST WORK INDICATES RELATIVELY HARD STEELS HAVE AN INTENSITY LISTED IN THE APPLICABLE MILITARY SPECIFICATIONS WHICH IS SUBSTANTIALLY LOWER THAN THAT CORRELATING WITH OPTIMUM FATIGUE LIFE.

FATIGUE LIFE AT OPTIMUM INTENSITY ACHIEVED DURING PHASE I WAS DEGRADED SUBSTANTIALLY BY DOUBLING OR TRIPLING BLAST CYCLE TIME TO ACHIEVE 200% AND 300% OF ALMEN SATURATION. THIS PHENOMENON WAS TO THE AUTHORS' KNOWLEDGE FIRST DOCUMENTED BY NEIL A. PERSON. (REF. 2)

WHEN UNDERSTANDING THE RAMIFICATIONS OF DATA ON MULTIPLES OF 100% SATURATION GENERATED IN OUR PHASE I PROJECT, IT IS NECESSARY TO EXAMINE THE CONCEPT OF SATURATION AND HOW IT CAN BE MANIPULATED. COVERAGE IS A MEASUREMENT OF HOW MUCH OF THE SURFACE IS IMPINGED. IT IS COMMONLY CONFUSED WITH SATURATION. ALMEN SATURATION IS A CALCULATION BASED ON ALMEN ARC HEIGHT STABILIZATION, A MEASURE OF THE AMOUNT OF ENERGY TRANSFER TO THE TEST STRIP. WORKPIECE SATURATION OR STABILIZATION OF ENERGY TRANSFER TO THE WORKPIECE MAY VARY FROM ALMEN SATURATION DEPENDING UPON VARIATION IN PART MATERIAL AND HARDNESS FROM THE 1070 ALMEN TEST STRIPS. TO BE 100% SATURATED, A WORKPIECE MUST BE 100% COVERED. TO BE 100% COVERED, HOWEVER, A WORKPIECE DOES NOT HAVE TO BE 100% SATURATED, AS THE IMPINGEMENTS CAUSING COVERAGE MAY BE FROM REBOUND, LOW IMPACT ANGLE, OR SECONDARY IMPACT. A PART HAS REACHED A 100% SATURATION WHEN THE SURFACE HAS BEEN ENTIRELY IMPINGED BY SHOT FROM A UNIFORM SIZED SHOT CHARGE TRAVELING AT THE MAXIMUM VELOCITY AND STRIKING AT THE ANGLE OF IMPACT CLOSEST TO 90 DEGREES. SINCE SATURATION IS A CALCULATION OF THE EFFECT OF THE NUMBER OF OPTIMUM SHOT IMPACTS ON THE WORKPIECE SURFACE, ANY PHENOMENON WHICH RESULTS IN A CHANGE IN THE NUMBER OF OPTIMUM ANGLE AND VELOCITY SHOT IMPACTS ON THE WORKPIECE SURFACE WILL NECESSARILY EFFECT SATURATION. 200% SATURATION IS NORMALLY ACHIEVED BY DOUBLING CYCLE TIME. DOUBLING THE SHOT FLOW RATE OF A BLAST AT A GIVEN VELOCITY WILL DOUBLE SATURATION. IN EQUIPMENT UTILIZING SHOT WHEELS AS A MEANS OF PROJECTING SHOT TO THE WORKPIECE, THIS IS PARTICULARLY A PROBLEM SINCE THERE WILL NOT BE THE NORMALLY ASSOCIATED SHOT VELOCITY DROP GIVING A TELLTALE DIFFERENCE IN ALMEN ARC HEIGHT WHEN INCREASING SHOT FLOW RATE. HENCE, A MEANS OF DETERMINING SHOT FLOW RATE IS CRITICAL TO OBTAINING OPTIMUM WORKPIECE PERFORMANCE FROM PEENING. PART SHAPE AND RESULTING SHIELDED OR PARTIALLY SHIELDED AREAS ALSO CAN EFFECT THE PERCENTAGE OF SATURATION.

SURFACE INTEGRITY DEGRADATION IN 200% SATURATION SAMPLES OVER THAT VISIBLE IN 100% SATURATION SAMPLES IS APPARENT IN SEM PHOTOS OF BOTH 3A AND 20A.

THIS SURFACE INTEGRITY DEGRADATION, HOWEVER, DOES NOT, UNDER SCANNING ELECTRON MICROSCOPE EXAMINATION, APPEAR THE SAME AS PSEF. 200% SATURATION SPECIMEN SURFACE CRACKS ARE MORE MULTI-FACETED, APPEAR SHALLOWER, SHORTER, AND MORE ANGULAR. ALTHOUGH 3A, 200% SHOWED SUBSTANTIALLY REDUCED FATIGUE LIFE FROM 3A, 100%; 20A, 200% ACTUALLY SHOWED SOME FATIGUE LIFE INCREASE OVER 20A, 100%. THE FATIGUE LIFE AT 20A, WHATEVER THE SATURATION LEVEL, WAS NEVER AS HIGH AS 3A, 100% OR 3A, 200%. SURFACE INTEGRITY DEGRADATION CAUSED BY MULTIPLES OF 100% SATURATION MAY BE RELATED TO STRAIN CRACKS RESULTING FROM CONTINUED IMPINGEMENT OF A SURFACE THAT HAS LOST A SUBSTANTIAL AMOUNT OF DUCTILITY DURING THE FIRST 100% OF SATURATION IN THE PEENING OPERATION DUE TO THE EFFECTS OF COLD WORK. ALTHOUGH THIS SURFACE INTEGRITY DEGRADATION WAS SUBSTANTIAL ENOUGH TO CAUSE SURFACE CRACK NUCLEATION AND RESULTANT REDUCED FATIGUE LIFE IN 3A SPECIMENS, THE DEPTH OF THESE SURFACE INTEGRITY PROBLEMS CAUSED BY 200% AND 300% SATURATION WAS ONLY A FRACTION OF THE DEPTH OF PSEF AT 20A. SINCE METALLOGRAPHIC EXAMINATION INDICATES PSEF PRESENT BECAME STRESS RISERS AND MAY BE CAUSAL TO THE RESULTANT PRIMARY CRACK NUCLEATION SITES, THE EFFECT ON THIS SURFACE OF THE WIDESPREAD, LOW MAGNITUDE SURFACE STRAIN CRACKS WAS NOT AS VIGOROUS AS IN 3A. THE EFFECT OF MULTIPLES OF 100% SATURATION ON THE UNIFORMITY OF THE PLASTICALLY DEFORMED LAYER WOULD BE TO INCREASE THE UNIFORMITY OF THE PLASTIC DEFORMATION LAYER. DUE TO BUDGETARY CONSTRAINTS, WE WERE UNABLE TO EXAMINE THIS PHENOMENON DURING PHASE I AND THE POSTULATION IS SUPPORTED ONLY BY FACE VALIDITY.

THIS IS ANOTHER AREA FOR FURTHER STUDY AS MANY AEROSPACE MANUFACTURERS USE SPECIFIED MULTIPLES OF 100% SATURATION IN SHOT PEENING SPECIFICATIONS.

THIS PLETHORA OF VARIABLES CAPABLE OF ALTERING THE PEENING PROCESS, AND HENCE WORKPIECE LIFE, IS THE REASON THAT EXACTING PROCESS CONTROL IS NECESSARY FOR ALL PROCESS VARIABLES.

WORKPIECE HARDNESS HAD A DRAMATIC EFFECT ON THE AMOUNT OF FATIGUE LIFE INCREASE GENERATED BY PEENING. ONE UNEXPECTED RESULT WAS THAT THE OPTIMUM INTENSITY WAS THE SAME AS THE HARDER 7075-T6, ALTHOUGH THE FATIGUE LIFE INCREASE WAS MUCH GREATER IN 7075-T73. WE THEORIZED THAT THE DECREASED HARDNESS OF 7075-T73 OVER T-6 RESULTED IN INCREASED PLASTIC DEFORMATION. AS WORKPIECE HARDNESS AND OTHER PHENOMENA RELATED TO MALLEABILITY DECREASED, PLASTIC DEFORMATION RESULTING IN PSEF INCREASED FOR A GIVEN INTENSITY LEVEL. THIS, HOWEVER, LEAVES SOME QUESTION AS TO WHY PSEF FORMATION AND HENCE FATIGUE LIFE PEAK DID NOT OCCUR AT LOWER INTENSITY LEVELS IN T-73 THAN IN T-6. THE GREATER INCREASE IN FATIGUE LIFE AND MORE DRAMATIC DROP OFF IN FATIGUE LIFE ABOVE THE FATIGUE LIFE PEAK, WE CONJECTURE, ARE BOTH A RESULT OF THE GREATER PLASTIC DEFORMATION OCCURRING AT A GIVEN INTENSITY ON A MORE MALLEABLE MATERIAL THAN 7075-T6.

PSEF SIZE AND ORIENTATION BOTH HAVE STATISTICALLY SIGNIFICANT RELATIONSHIPS WITH PEENING INTENSITY AS DO CRACK NUCLEATION SITE AND NUMBER OF SECONDARY CRACKS. THE RESIDUAL STRESS PROFILE OF SPECIMENS PEENED IN THE OPTIMUM RANGE SHOW A GREATER MAGNITUDE OF MAXIMUM COMPRESSION WHICH OCCURS AT A SHALLOWER DEPTH THAN SPECIMENS PEENED AT SUBSTANTIALLY HIGHER RANGES. AS INTENSITY INCREASES, THE LAYER OF MAXIMUM COMPRESSION IS DEEPER ALTHOUGH THE PEAK VALUE OF THIS COMPRESSION IS LOWER. WE BELIEVE THIS PHENOMENON MAY BE PARTIALLY LINKED TO PSEF AND THE RESULTANT STRAIN THAT COULD OCCUR WHERE GAPS AND VOIDS RELATED TO PSEF IN THE SURFACE ALLOW SOME MICROSCOPIC MOVEMENT OF THE SURFACE. UNIFORMITY OF THE PLASTIC DEFORMATION LAYER AND MEDIA SIZE MAY BE RELATED.

MEDIA SIZE AND FATIGUE LIFE WERE SHOWN TO HAVE A CONSISTENT NEGATIVE CORRELATION.

IT IS THE AUTHORS' OPINION THAT THE STATISTICAL RELATIONSHIP BETWEEN PSEF DEPTH AND/OR QUANTITY AND FATIGUE LIFE WAS LIMITED BY THE RELATIVELY SMALL SAMPLE SIZE TAKEN. (ONE METALLOGRAPHIC SAMPLE PER SPECIMEN EXAMINED.) HAD SEVERAL SAMPLES BEEN TAKEN PER SPECIMEN EXAMINED, AND ALL SPECIMEN EXAMINED, THE DATA RELATIONSHIP MAY HAVE PROVED STRONGER. THE STRONG STATISTICAL RELATIONSHIP OF INTENSITY AND PSEF MAY BE AN INDICATION THAT THE STATISTICAL RELATIONSHIP OF PSEF DEPTH AND ORIENTATION TO THE SURFACE TO FATIGUE LIFE WOULD BE MORE SIGNIFICANT IN A LARGER SAMPLING.

VERIFICATION THAT THERE ARE SERIOUS QUESTIONS ABOUT THE VALIDITY, ACCURACY, CONSISTENCY, AND COMPLETENESS OF SOME AREAS OF APPLICABLE SPECIFICATIONS HAS BEEN DEMONSTRATED. MUCH RESEARCH NEEDS TO BE DONE BEFORE A DEFINITIVE FORMULA FOR PREDICTING THE BENEFITS AVAILABLE FROM SHOT PEENING CAN BE OBTAINED. THIS PROJECT HAS, HOWEVER, SERVED AS A DEMONSTRATION THAT, THROUGH QUANTIFICATION OF THE METALLURGICAL EFFECTS OF PEENING CAUSAL TO FATIGUE LIFE BENEFITS, SUCH A FORMULA COULD BE POSSIBLE THROUGH RIGOROUS EXAMINATION OF ALL THE VARIABLES.

## 5.1 SUMMARY

EXAMINATION OF THE DATA REVEALED DRAMATIC CHANGES IN THE DIRECTION OF THE TRENDS AROUND 3A, 5A, AND 7A INTENSITY. ALL COMPARISONS WERE CONDUCTED IN THREE PARTS: TOTAL DATA; DATA BETWEEN 0A AND 3A, 5A AND 7A; AND DATA BETWEEN 3A, 5A, 7A AND 20A.

THE STATISTICAL TESTS REVEALED SIGNIFICANT CORRELATION BETWEEN INTENSITY AND FATIGUE LIFE, INTENSITY AND THE NUMBER OF SECONDARY FAILURE SITES, MEDIA SIZE AND FATIGUE LIFE AND, FOR T6 ALONE, INTENSITY AND PSEF DEPTH. PSEF DEPTH DID NOT CORRELATE WITH FATIGUE LIFE NOR WITH THE NUMBER OF SECONDARY FAILURE SITES. IN T6 AND 3A INTENSITY, SATURATION AND MEDIA SIZE TOGETHER CORRELATED WELL WITH FATIGUE LIFE. ON THE OTHER HAND, THE CORRELATION OF INTENSITY AND MEDIA SIZE WITH FATIGUE LIFE MORE THAN DOUBLED ONCE THE BASELINE DATA (UNPEENED STATE) WAS REMOVED AND ALL LEVELS BETWEEN 1A AND 20A WERE RETAINED. FINALLY, THE EXAMINATION OF CRACK NUCLEATION LOCATIONS REVEALED THAT ALMEN INTENSITY AND PSEF CORRELATED WELL WITH FAILURE LOCATION ESPECIALLY WHEN THE INTENSITY EXCEEDS 3A ALMEN. ALL THE REPORTED CORRELATIONS WERE STATISTICALLY SIGNIFICANT EXCEPT FOR THOSE FEW WHICH INVOLVED PSEF DEPTH.

## 6.0 CONCLUSION

THE RESULTS OF THIS INVESTIGATION INDICATE THAT MANIPULATION OF PEENING VARIABLES CAN DRASTICALLY AFFECT FATIGUE LIFE. CURRENT MILITARY SPECIFICATIONS PRESCRIBE PEENING INTENSITY LEVELS WHICH MAY BE HIGHER THAN THOSE CORRELATED WITH OPTIMUM WORKPIECE LIFE IN SOME ALUMINUM ALLOYS. OTHER AREAS SUCH AS PERCENT OF ALMEN SATURATION AND MEDIA SIZE MAY NOT BE ADEQUATELY PRESCRIBED IN CURRENT MILITARY SPECIFICATIONS. IN APPLICATIONS WHERE THE AMOUNT OF BENEFIT DERIVED FROM PEENING MUST BE DEPENDED UPON FOR A COMPONENT TO YIELD THE REQUIRED FATIGUE LIFE, PRELIMINARY TEST WORK AND EXTENSIVE EQUIPMENT AND QUALITY ASSURANCE CONTROLS SHOULD BE UTILIZED. A CONTINUING PROJECT GOAL OF PREDICTABILITY OF THE PERCENTAGE OF FATIGUE LIFE INCREASE AVAILABLE FROM SHOT PEENING IN PHASE II AND PHASE III OF THIS PROGRAM WILL REQUIRE AN EXHAUSTIVE APPROACH TO IDENTIFYING THE EFFECTS OF THE PROCESS ON THE METALLURGICAL STRUCTURE OF VARIOUS MATERIALS.

## 7.0 RECOMMENDATIONS

THE FOLLOWING ARE RECOMMENDED FOR FURTHER STUDY.

- 1) SINCE PURE FATIGUE OR STRESS CORROSION RESISTANCE RARELY OCCUR IN ACTUAL APPLICATION, A STUDY OF THE EFFECT OF PEENING ON VARIOUS INTERACTIONS OF CORROSION AND FATIGUE WOULD ALLOW MORE POSITIVE PRESCRIPTION OF OPTIMUM PARAMETERS IN ACTUAL PRODUCTION APPLICATIONS.
- 2) AN INVESTIGATION SHOULD BE CONDUCTED INTO THE EFFECTS OF VARYING LEVELS OF BROKEN MEDIA CONTENT IN THE SHOT CHARGE ON FATIGUE LIFE.
- 3) FURTHER DEFINITION OF THE EFFECTS OF MULTIPLES OF 100% SATURATION ON VARYING MATERIALS IS REQUIRED.
- 4) EXAMINATION OF CURRENT MILITARY AND INDUSTRY SHOT PEENING SPECIFICATIONS FOR ADEQUATE PRESCRIPTION OF PEENING PROCESS VARIABLES AND ADEQUATE CONTROL OF THESE VARIABLES DURING THE PROCESS.
- 5) DEFINITION OF THE EFFECTS OF THE TYPE OF LOAD APPLIED ON THE QUALITATIVE OPTIMUM OF PEENING PROCESS PARAMETERS IS REQUIRED.
- 6) DEFINITION OF THE EFFECTS OF NOTCHED SPECIMEN ON THE QUALITATIVE OPTIMUM OF PEENING PROCESS PARAMETERS IS REQUIRED.

#### REFERENCES

- (1). "EFFECT OF SHOT PEENING VARIABLES ON BENDING FATIGUE."  
J. A. HORWATH, FIRST INTERNATIONAL SYMPOSIUM ON SHOT  
PEENING, PARIS, FRANCE, SEPTEMBER, 1981. (PROCEEDINGS,  
P. 229-235, PERGAMON PRESS)
- (2). "EFFECT OF SHOT PEENING VARIABLES ON FATIGUE OF ALUMINUM  
FORGINGS" NEAL L. PERSON, METAL PROGRESS, JULY, 1981.
- (3). SHOT PEENING, WHEELABRATOR-FRYE, INC., (P. 27) 1959.
- (4). "EFFECTS OF PEENING ON FATIGUE LIFE OF WROUGHT 5454  
ALUMINUM AUTOMOTIVE ROAD WHEELS" ROGER S. SIMPSON,  
DAVID McCAGG, SECOND INTERNATIONAL CONFERENCE ON  
SHOT PEENING, CHICAGO, IL, MAY 1984.
- (5). "EFFECTS OF SHOT PEENING ON FATIGUE OF Ti-6AL-4V POWDER  
COMPACTS; J. T. CAMMETT, D. EYLON, P.R. SMITH,  
C.M. COOKE, F. H. FROES
- (6). "INFLUENCE OF THE SHOT PEENING PARAMETERS ON THE SURFACE  
LAYER PROPERTIES AND THE FATIGUE LIFE OF Ti-6AL-4V"  
L. WAGNER AND G. LUTJERING, 2ND INTERNATIONAL CONFERENCE ON  
SHOT PEENING, CHICAGO, IL, USA, MAY 1984
- (7). MIL-S-13165B "MILITARY SPECIFICATION: SHOT PEENING OF  
METAL PARTS" DECEMBER 31, 1966
- (8). MIL-STD-852 "MILITARY STANDARD: GLASS BEAD PEENING  
PROCEDURES" (USAF) SEPTEMBER 21, 1965
- (9). "INVESTIGATION ON THE MICROSTRUCTURE IN SHOT PEENING  
SURFACE STRAINING LAYER OF MATERIALS" WANG RENZHI,  
LI XIANGBIN, TAN YONGGUI AND YAN MINGGAO, 1ST INTERNATIONAL  
CONFERENCE ON SHOT PEENING, SEPTEMBER 1981
- (10). "INFLUENCE OF SHOT PEENING ON SURFACE INTEGRITY OF SOME  
MACHINED AEROSPACE MATERIALS" W.P. KOSTER, L. R. GATTO  
AND J. T. CAMMETT, 1ST INTERNATIONAL CONFERENCE ON SHOT  
PEENING, SEPTEMBER 1981.
- (11). "THE IMPROVEMENT OF FATIGUE AND SURFACE CHARACTERISTICS  
OF ALLOY 7075-T6 BY SECONDARY PEENING WITH GLASS BEADS"  
A. SNOWMAN AND R. G. SCHMIDT, 1ST INTERNATIONAL CONFERENCE  
ON SHOT PEENING, SEPTEMBER 1981

- (12). "EFFECT OF SHOT PEENING METHODS ON THE FATIGUE BEHAVIOR OF ALLOY 7075-T6" G. S. WAS, R. M. FELLOUX AND M.C. FRABOLOT, 1ST INTERNATIONAL CONFERENCE ON SHOT PEENING, SEPTEMBER, 1981
- (13). "SATURATION AND INTENSITY OVERPEENING OF ALUMINUM ALLOYS" ROGER S. SIMPSON, SAE AIRLINE PLATING AND SURFACE FINISHING CONFERENCE, 1984
- (14). "THE SHOT PEENING OF METALS-MECHANICS AND STRUCTURES" S. T. S. AL-HASSANI, SHOT PEENING FOR ADVANCED AEROSPACE DESIGN SP-528, AEROSPACE CONGRESS & EXPOSITION, 1982
- (15). "SHOT PEENING-CONTROL & MEASUREMENT" MICHAEL M. WOELFEL, AEROSPACE CONGRESS & EXPOSITION, 1982
- (16). "SHOT BLASTING AND ITS EFFECT ON FATIGUE LIFE" F.P. ZIMMERLI, HEAT TREATING AND FORGING pp 534-46 (NOVEMBER 1940)
- (17). "SHOT BLASTING AIRCRAFT ENGINE PARTS" AMERICAN MACHINIST pp 89-9 (JUNE 24, 1943)
- (18). "FATIGUE LIFE OF STRESSED PARTS INCREASED BY SHOT PEENING" D. C. TURNBULL, AMERICAN MACHINIST pp 83-6 (AUGUST 31, 1944)
- (19). "PEENING & PEACE TIME PRODUCTS" K. H. BARNES, MILL AND FACTORY, pp 129-31 (APRIL 1946)
- (20). "ADDITIONAL BENEFITS OF SHOT PEENING" WHEELABRATOR-FRYE CORPORATION, 1959
- (21). "THE USE OF SPECIALISED SHOT PEENING TECHNIQUES ON TAPERED LEAF SUSPENSION SPRINGS FOR ROAD VEHICLES" C. G. ROBINSON AND E. SMART, 2nd INTERNATIONAL CONFERENCE ON SHOT PEENING, MAY 1984
- (22). "INFLUENCE OF SHOT PEENING ON FATIGUE AND CORROSION-FATIGUE BEHAVIOR OF STRUCTURAL STEEL" D. KIRK AND M. JARRET, 2nd INTERNATIONAL CONFERENCE ON SHOT PEENING, MAY, 1984
- (23). "SHOT BLASTING TO INCREASE FATIGUE RESISTANCE.", J. O. ALMEN, SAE JOURNAL, VOL. 51, NO. 7, P. 248, JULY, 1943.

APPENDIX A  
SPECIMEN GEOMETRY

36

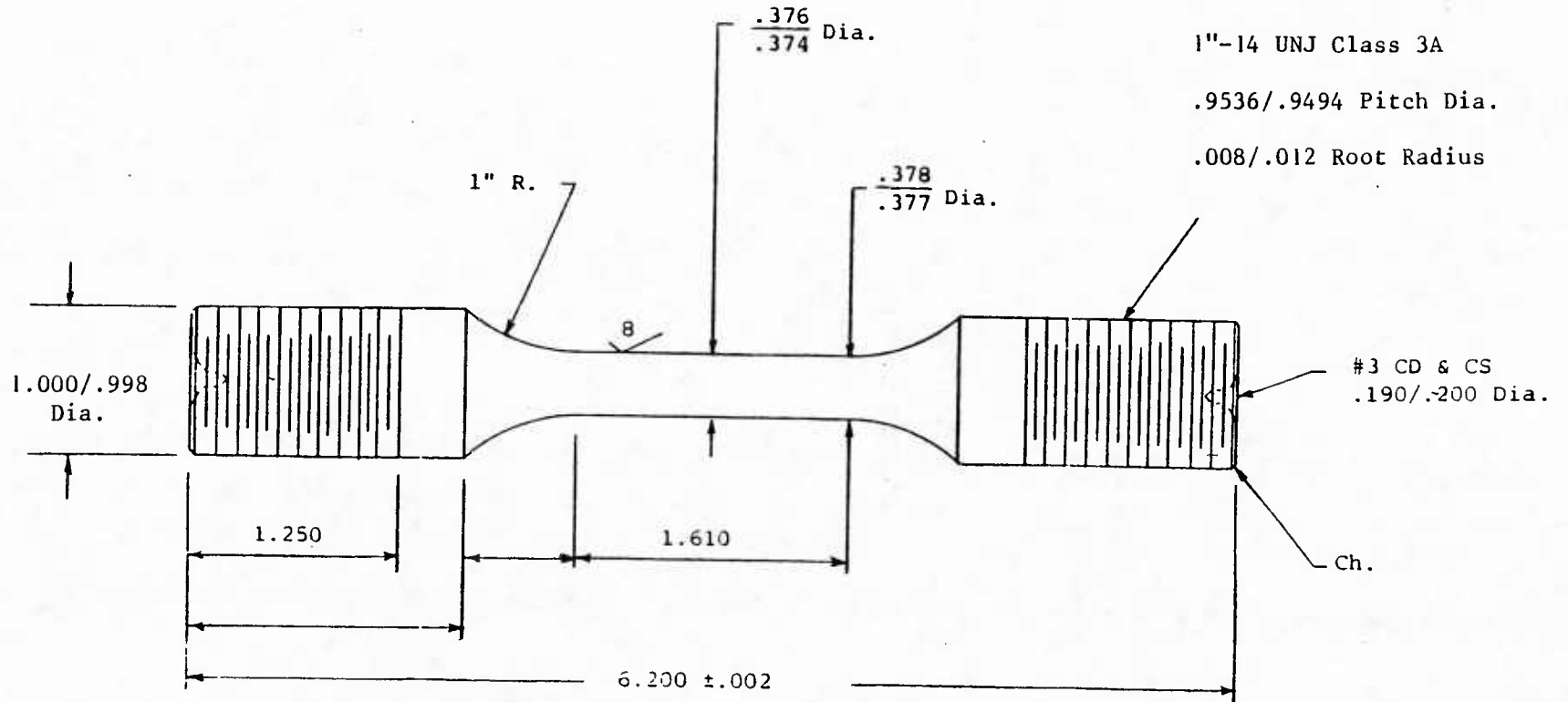

Drawing No. FAT-16100 MOD.  
1-4-83

APPENDIX B  
RESIDUAL STRESS PROFILES

X-RAY DIFFRACTION RESIDUAL STRESS ANALYSIS  
2157-35238 S/N 3A /100  
6305.06, 7075-T6, 100% SHOT PEENED

88

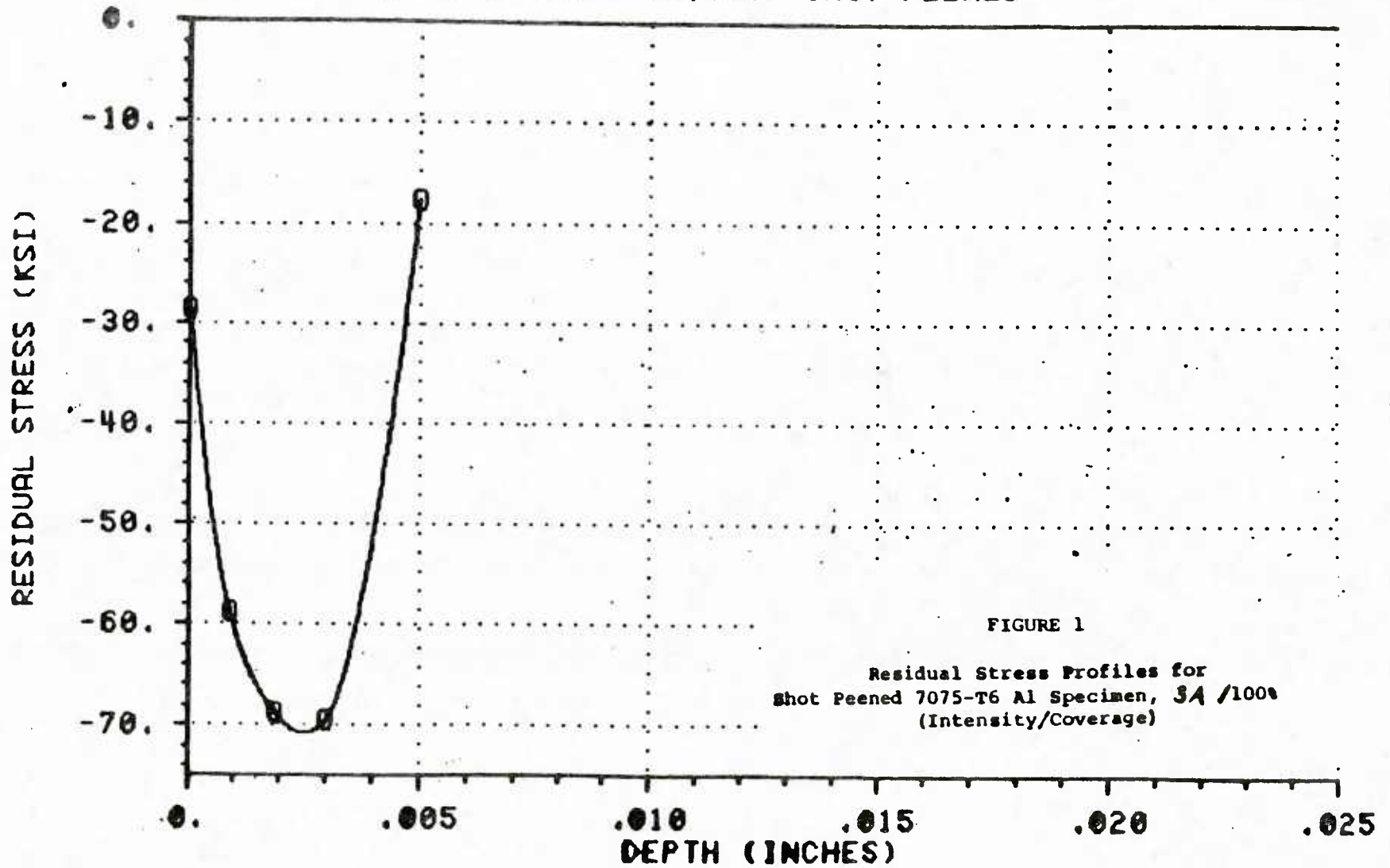

X-RAY DIFFRACTION RESIDUAL STRESS ANALYSIS  
2157-35238 S/N 018A/100  
8305.12,7075-T6,100% SHOT PEENED

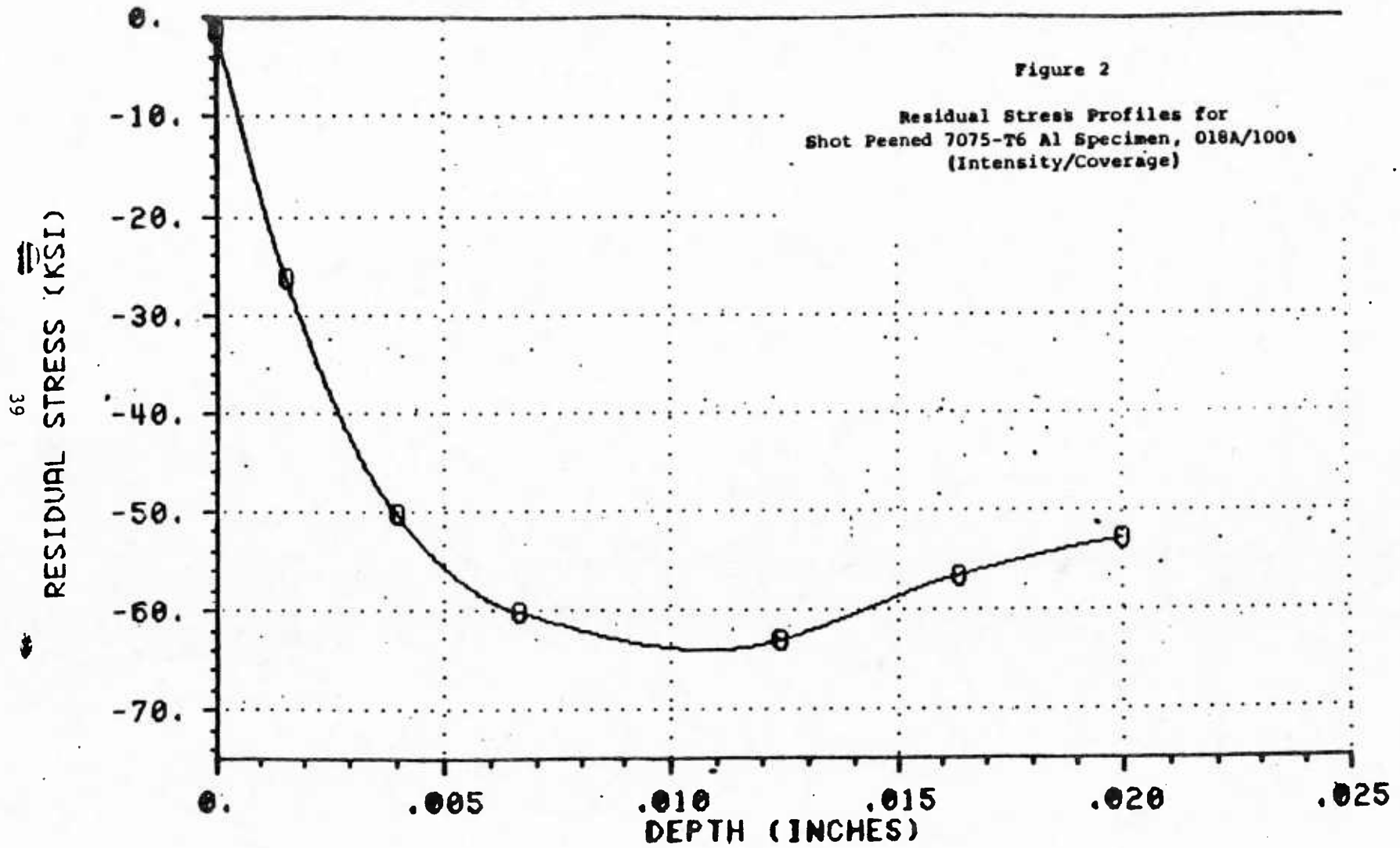

RESIDUAL STRESS (KSI)

DEPTH (INCHES)

U218901