

AD-A156 112

EFFECTS OF TEMPERATURE ON THE TENSILE STRENGTH AND  
ELASTIC MODULUS OF COMPOSITE MATERIAL (U) NAVAL  
POSTGRADUATE SCHOOL MONTEREY CA H R BAE MAR 85

1/4

UNCLASSIFIED

F/G 11/4

NL



11/4

11/4

11/4

END  
DATE  
FILMED  
8-85

(1)

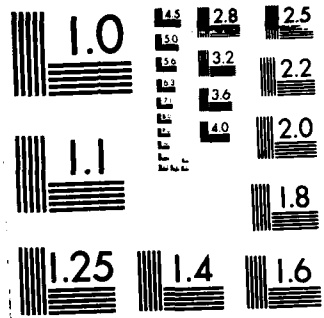

MICROCOPY RESOLUTION TEST CHART  
NATIONAL BUREAU OF STANDARDS-1963-A

AD-A156 112

# NAVAL POSTGRADUATE SCHOOL

Monterey, California



DTIC  
SELECTE  
JUL 03 1985  
S D  
G

## THESIS

EFFECTS OF TEMPERATURE ON THE TENSILE  
STRENGTH AND ELASTIC MODULUS OF  
COMPOSITE MATERIAL

by

Hae Ryong Bae

March 1985

Thesis Advisor:

David Salinas

DTIC FILE COPY

Approved for public release; distribution unlimited

85 6 7\_085

UNCLASSIFIED

SECURITY CLASSIFICATION OF THIS PAGE (When Data Entered)

REPORT DOCUMENTATION PAGE		READ INSTRUCTIONS BEFORE COMPLETING FORM
1. REPORT NUMBER	2. GOVT ACCESSION NO. AD-4156112	3. RECIPIENT'S CATALOG NUMBER
4. TITLE (and Subtitle) Effects of Temperature on the Tensile Strength and Elastic Modulus of Composite Material		5. TYPE OF REPORT & PERIOD COVERED Master's Thesis March 1985
		6. PERFORMING ORG. REPORT NUMBER
7. AUTHOR(s) Hae Ryong Bae		8. CONTRACT OR GRANT NUMBER(s)
9. PERFORMING ORGANIZATION NAME AND ADDRESS Naval Postgraduate School Monterey, California 93943		10. PROGRAM ELEMENT, PROJECT, TASK AREA & WORK UNIT NUMBERS
11. CONTROLLING OFFICE NAME AND ADDRESS Naval Postgraduate School Monterey, California 93943		12. REPORT DATE March 1985
		13. NUMBER OF PAGES 79
14. MONITORING AGENCY NAME & ADDRESS (if different from Controlling Office)		15. SECURITY CLASS. (of this report) Unclassified
		15a. DECLASSIFICATION/DOWNGRADING SCHEDULE
16. DISTRIBUTION STATEMENT (of this Report) Approved for public release; distribution unlimited		
17. DISTRIBUTION STATEMENT (of the abstract entered in Block 20, if different from Report)		
18. SUPPLEMENTARY NOTES		
19. KEY WORDS (Continue on reverse side if necessary and identify by block number) Composite Materials; Graphite/Epoxy; Woven Style		
20. ABSTRACT (Continue on reverse side if necessary and identify by block number) An experimental investigation was made to determine the ultimate tensile strength and elastic modulus of HMF 330/34 woven style graphite epoxy exposed to elevated temperatures: (16°C, 50°C, 80°C, 110°C, 140°C, and 170°C). Specimen were of three different layups: (0/45/45/90) <sub>S</sub> , (45/0/-45/90) <sub>S</sub> and (45/90/-45/0) <sub>S</sub> . An instron universal testing machine with 20,000 lb maximum load capacity was used to apply the uniaxial		

DD FORM 1 JAN 73 473

EDITION OF 1 NOV 68 IS OBSOLETE  
S/N 0102-LF-014-6601

UNCLASSIFIED

SECURITY CLASSIFICATION OF THIS PAGE (When Data Entered)

CONFIDENTIAL

UNCLASSIFIED

SECURITY CLASSIFICATION OF THIS PAGE (When Data Entered)

#20 - ABSTRACT - (CONTINUED)

tensile loading. A Marshall clamshell furnace was used for maintaining the elevated temperatures. Results of the investigation indicate that ultimate tensile strength decreases with temperature increase in the (0/45/-45/90)<sub>S</sub> orientation panel. For (45/0/-45/90)<sub>S</sub> and (45/90/-45/0)<sub>S</sub> orientation panels, ultimate tensile strength increases with temperature up to 140°C (284°F), and decreases above 140°C (284°F). In all cases, the elastic modulus decreases as temperature increases.

S. N 0102- LF- 014- 6601

UNCLASSIFIED

SECURITY CLASSIFICATION OF THIS PAGE (When Data Entered)

Approved for public release; distribution unlimited.

Effects of Temperature on the Tensile Strength  
and Elastic Modulus of Composite Material

by

Hae Ryong Bae  
Commander, Republic of Korea Navy  
B.S., Korea Naval Academy, 1972  
B.S., Korea Seoul National University, 1976

Submitted in partial fulfillment of the  
requirements for the degree of

MASTER OF SCIENCE IN MECHANICAL ENGINEERING

from the

NAVAL POSTGRADUATE SCHOOL

March 1985

Accession For	
NTIS GRA&I	<input checked="" type="checkbox"/>
DTIC TAB	<input checked="" type="checkbox"/>
Unannounced	<input type="checkbox"/>
Justification	
By _____	
Distribution/	
Availability Codes	
Dist	Avail and/or Special
A/	

Author:

Hae Ryong Bae  
Hae Ryong Bae

Approved by:

David Salinas  
David Salinas, Thesis Advisor

Paul J. Marto  
Paul J. Marto, Chairman,  
Department of Mechanical Engineering

John N. Dyer  
John N. Dyer,  
Dean of Science and Engineering



### ABSTRACT

An experimental investigation was made to determine the ultimate tensile strength and elastic modulus of HMF 330/34 woven style graphite epoxy exposed to elevated temperatures: (16°C, 50°C, 80°C, 110°C, 140°C, and 170°C). Specimen were of three different layups:  $(0/45/-45/90)_S$ ,  $(45/0/-45/90)_S$  and  $(45/90/-45/0)_S$ . An instron universal testing machine with 20,000 lb maximum load capacity was used to apply the uniaxial tensile loading. A Marshall clamshell furnace was used for maintaining the elevated temperatures. Results of the investigation indicate that ultimate tensile strength decreases with temperature increase in the  $(0/45/-45/90)_S$  orientation panel. For  $(45/0/-45/90)_S$  and  $(45/90/-45/0)_S$  orientation panels, ultimate tensile strength increases with temperature up to 140°C (284°F), and decreases above 140°C (284°F). In all cases, the elastic modulus decreases as temperature increases.

TABLE OF CONTENTS

I.	INTRODUCTION -----	11
II.	RECENT RESEARCH -----	14
III.	OBJECTIVES AND SCOPE OF THE TEST PROGRAM -----	17
	A. OBJECTIVES OF THE TEST PROGRAM -----	17
	B. SCOPE OF THE TEST PROGRAM -----	17
IV.	DESCRIPTION OF THE SPECIMENS -----	18
	A. SPECIMEN SHAPE -----	18
	B. SPECIMEN DIMENSIONS -----	25
	C. MANUFACTURE OF SPECIMEN AND SPECIMEN IDENTIFICATION -----	28
V.	EXPERIMENTAL PROCEDURES -----	31
	A. TESTING EQUIPMENT -----	31
	B. EXPERIMENTAL PROCEDURE -----	34
VI.	ANALYSIS -----	37
	A. ULTIMATE TENSILE STRENGTH -----	37
	B. ELASTIC MODULUS -----	37
VII.	EXPERIMENTAL RESULTS -----	38
	A. RUPTURE FAILURE SHAPE -----	50
VIII.	CONCLUSIONS AND RECOMMENDATIONS -----	53
	A. CONCLUSIONS -----	53
	1. Ultimate Tensile Strength -----	53
	2. Elastic Modulus -----	54
	3. Moisture -----	54
	4. Failure -----	54

B. RECOMMENDATIONS -----	55
1. Recommendations from This Investigation -----	55
2. Suggestions for Future Research Activities -----	55
APPENDIX A: NOMENCLATURE -----	57
APPENDIX B: TENSILE TEST SPECIMEN DIMENSIONS OF COMPOSITE MATERIALS AT ELEVATED TEMPERATURE -----	58
APPENDIX C: MANUFACTURING OF SPECIMEN -----	59
APPENDIX D: NEW DESIGN WEDGE COUPLING -----	62
APPENDIX E: STRAIN RATE OF COMPOSITE MATERIAL AT ELEVATED TEMPERATURE -----	67
APPENDIX F: EXPERIMENTAL DATA -----	69
APPENDIX G: SPECIMEN WEIGHT -----	72
LIST OF REFERENCES -----	74
BIBLIOGRAPHY -----	77
INITIAL DISTRIBUTION LIST -----	78

LIST OF TABLES

I.	Specimen Identification -----	30
II.	Failure Point in #1, #2, and #3 Panel -----	51
III.	Tensile Test Specimen Dimensions of Composite Material at Elevated Temperature -----	58
IV.	Strain Rate of Composite Material at Elevated Temperature -----	68
V.	#1 Panel Experimental Data at Elevated Temperature -----	69
VI.	#2 Panel Experimental Data at Elevated Temperature -----	70
VII.	#3 Panel Experimental Data at Elevated Temperature -----	71
VIII.	Specimen Weight at Elevated Temperature -----	72
IX.	Specimen Weight at Elevated Temperature -----	73

LIST OF FIGURES

1.1	Cross and Woven Type Laminates -----	13
4.1	Tensile Testing Specimen's Shape -----	19
4.2	Two-Dimensional Flow Lines in Channel -----	21
4.3	Analytical Models for a Pure Tensile Case -----	23
4.4	Analytical Models for a Pure Tensile Case -----	24
4.5	Stresses in Tab Region -----	25
4.6	Theoretical Stresses in Tabbed Specimens -----	26
4.7	Peak Stress vs Tab Angle -----	27
4.8	Specimen Dimension -----	29
5.1	Placement of Thermocouples and Controller -----	32
5.2	Out-of-Plane Bending of Tension Specimens -----	35
5.3	Gauge Mark -----	35
7.1	Ultimate Tensile Strength vs Temperature of #1 Panel (0/45/-45/90) <sub>s</sub> -----	39
7.2	Ultimate Tensile Strength vs Temperature of #2 Panel (45/0/-45/90) <sub>s</sub> -----	40
7.3	Ultimate Tensile Strength vs Temperature of #3 Panel (45/90/-45/0) <sub>s</sub> -----	41
7.4	Ultimate Tensile Strength vs Temperature of #1, #2, and #3 Panel -----	42
7.5	Elastic Modulus vs Temperature of #1 Panel (0/45/-45/90) <sub>s</sub> -----	43
7.6	Elastic Modulus vs Temperature of #2 Panel (45/0/-45/90) <sub>s</sub> -----	44
7.7	Elastic Modulus vs Temperature of #3 Panel (45/90/-45/0) <sub>s</sub> -----	45
7.8	Elastic Modulus vs Temperature of #1, #2, and #3 Panel -----	46

7.9	Load vs Fiber Broken -----	47
7.10	Failure at Tab Region -----	48
7.11	#1 and #2 Panel Failure Location -----	49
7.12	#3 Panel Failure Location -----	50
7.13	Failure Shape -----	52
C.1	Exploded Layup of the Panels -----	60
C.2	Actual Cure Cycle of the Specimens -----	61
D.1	Big Jaw Configuration -----	63
D.2	New Design Wedge Coupling System -----	64
D.3	New Design Wedge Coupling System -----	65
D.4	New Design Wedge Coupling System -----	66

### ACKNOWLEDGEMENT

I wish to express my most grateful appreciation to Professor David Salinas for his guidance and enthusiasm and Dr. J.A. Bailie of Lockheed Missiles and Space Company for his help and advice. In addition, I wish to express my deepest gratitude and undying love to my wife, Young Whee, and my sons, Se Jin, and Se Wha, without whose continuous support and patience this work would not have been possible. I am grateful to Lockheed Missiles and Space Co. Ltd., who manufactured all the specimens. I am in appreciation of the considerable assistance rendered by Thomas A. McCord, and Willard Dames who manufactured all the grip assemblies. The author would also like to mention all those in the Material Science Department who offered recommendations, especially Tom Kellogg.

## I. INTRODUCTION

Composite materials have been in use for a long time. Materials consisting of two distinct components or phases combined in adequate proportion to achieve properties more convenient to suit man's needs, and presenting a higher strength than one of the phase alone, have been known since the earliest times of human history.

One example of such type of material which appeared in ancient history is the mongol bow (about 800 BC) that was made of a composite of animal's tendons, silk, and wood, bonded together by means of adhesive [Ref. 1].

More recently, fiber-reinforced resin composites that have high strength-to-weight and stiffness-to-weight ratios have become important in weight-sensitive applications such as aircraft and space vehicles. Long fibers in various forms are inherently much stiffer and stronger than the same material in bulk form [Ref. 2]. For example, the strength of steel fiber is approximately 4.14 MPA (600,000 PSI), compared to a strength of 1.04 MPA (150,000 PSI) for steel in its common bulk form. Thus the use of steel fiber in place of common steel results in a four-fold reduction in weight. Actually the use of fiber requires their embedment in a matrix of another material in order to achieve a useful structural form. However, even with embedment, fiber reinforced materials offer

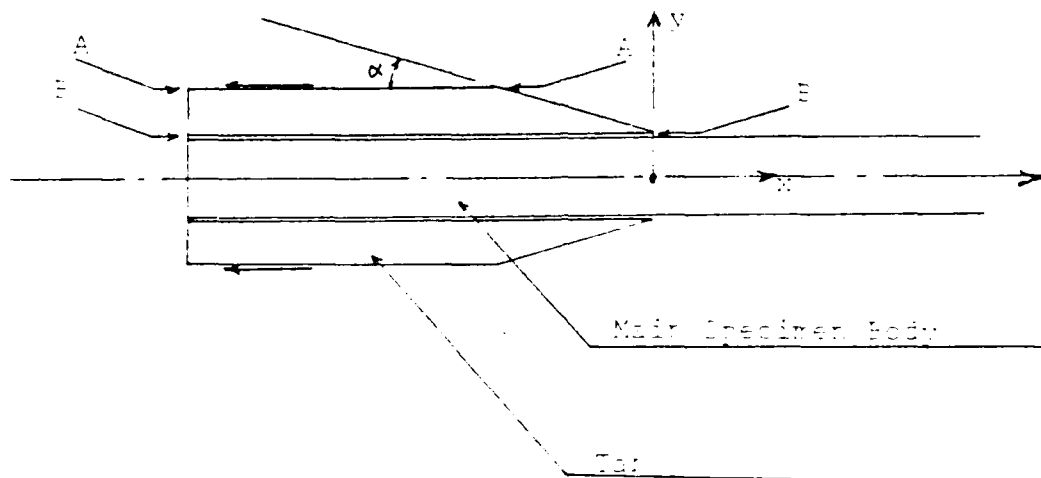

Figure 4.5. Stresses in Tab Region

[Ref. 16] stated that peak stresses (maximum stresses) in the specimen were lower for specimens with the tapered-tabs, compared to the specimen without tapered-tab ends.

R.N. Hadcock et al [Ref. 7] stated that the greatest ultimate tensile strength can be obtained from specimens with long, shallow tapered-tab.

#### B. SPECIMEN DIMENSIONS

The physical dimensions of the test specimen for this investigation was the result of four considerations:

- a) To assure constant temperature distribution throughout the specimen length during one specified elevated

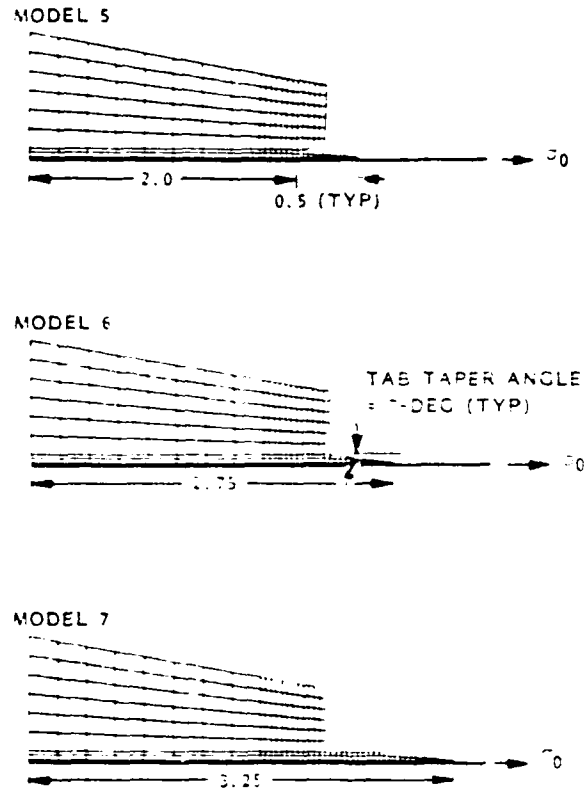

Figure 4.4. Analytical Models for a Pure Tensile Case

less than  $30^\circ$ . As  $\tau_{xy}$  and  $\sigma_x$  are almost linearly decreasing functions of the bevel angle, small tab angles give small  $\tau_{xy}$  and  $\sigma_x$  stresses. Although tab angles less than  $10^\circ$  would be more fruitful, the practicality of providing specimens with tab bevel angles less than  $10^\circ$  must be addressed in terms of economy of specimen manufacture. Murat H. Kural et al

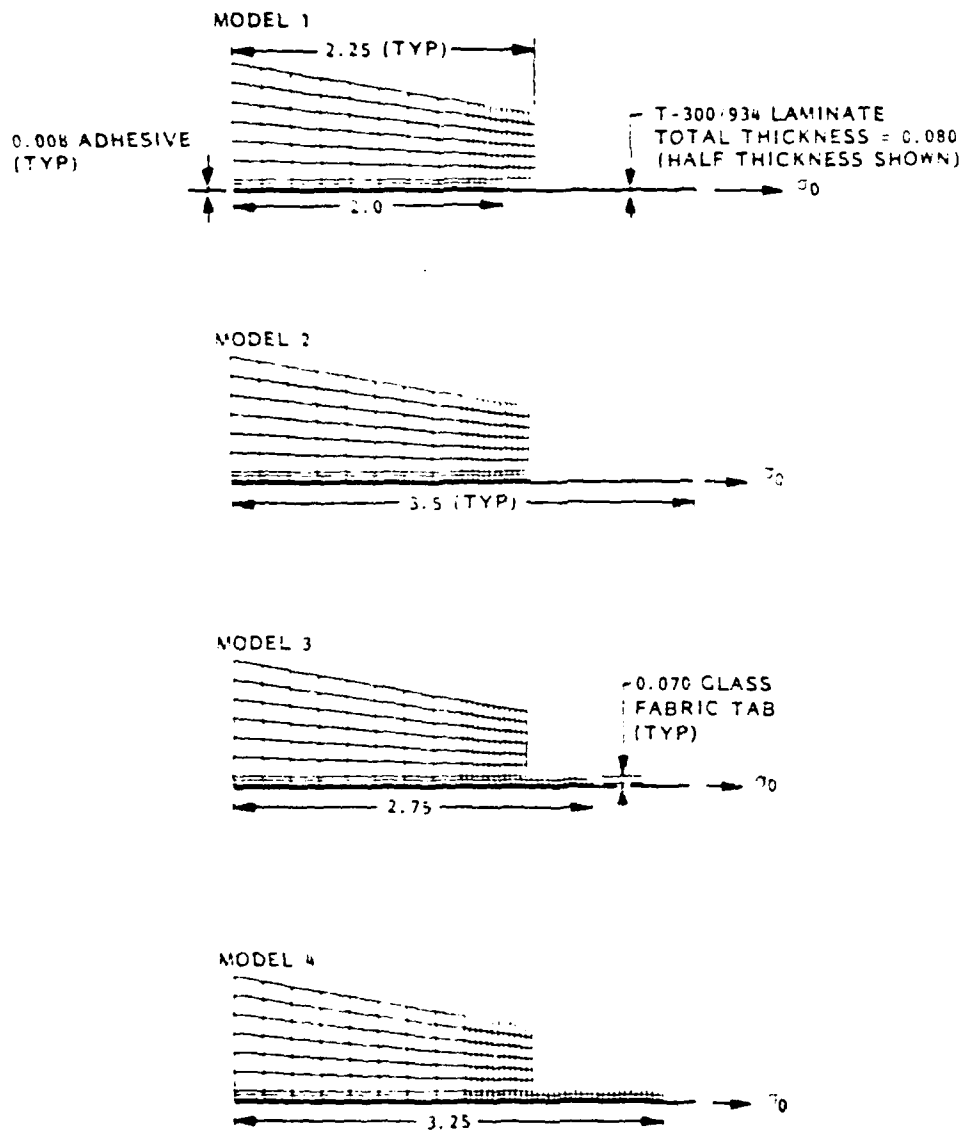

Figure 4.3 Analytical Models for a Pure Tensile Case

The relation between debonding and tab length was studied by Murat H. Kural et al [Ref. 16]. Figures 4.3 and 4.4 show the analytical models considered in his study. He stated that the peel stresses are significantly increased for the long unsupported square-end tabbed specimen; but slightly increased for the long unsupported tapered-end tabbed specimen with  $7^\circ$  bevel angle.

- b) The tab bevel angle (approximately  $10^\circ$ ) was made as small as possible to reduce debonding.

The relation between debonding and tab bevel angle was studied by Donald W. Oplinger et al [Ref. 11]. Figure 4.5 shows the geometry of the specimen considered in his analysis. His interest centered on the bondline shear stress distribution along the line B-B. The boundary condition was the uniform horizontal motion along line A-A. The uniform load reacted at the right side of the sketch. Bondline stress distributions, as multiples of  $\sigma_{nom}$ , which were calculated, are shown in Figure 4.6. Figure 4.7 focuses on the peak values of the three stresses as a function of the tab bevel angle. In Figures 4.5-4.7,  $\sigma_{nom}$  indicates uniform nominal tensile stress,  $\sigma_y$  indicates the peak stress,  $\tau_{xy}$  indicates bond shear stress,  $\sigma_x$  indicates tensile stress concentration, and  $\alpha$  indicates tab bevel angle.

Judging from the results in Figure 4.7, tab angles of  $30^\circ$  or less make the  $\sigma_y$  stress small enough to be negligible, while the  $\sigma_x$  and  $\tau_{xy}$  stresses are significant even for tab angles

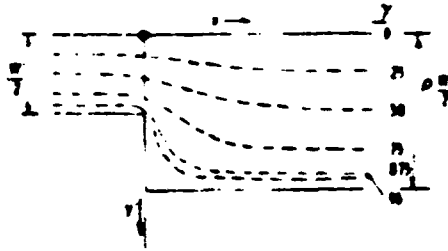

Figure 4.2. Two-Dimensional Flow Lines in Channel

- f) The straight-side tabbed specimen is the most widely used composite material tensile test specimen and it is the cheapest to manufacture [Ref. 7].

These tabs are used to spread the load as uniformly as possible over the specimen ends, preventing the occurrence of cracks caused by tightening of the grips [Ref. 15]. However, there is a problem of debonding between the main body of the specimen and the tab. This causes early debonding failure before tensile failure of the specimens. The debonding can be caused by peel stresses<sup>6</sup> and shear stresses in the debonded layer [Ref. 11]. Two methods were used to reduce this fault.

- a) Long<sup>7</sup> supported tapered-end tabbed specimen with 10° bevel angle was used to reduce debonding, and therefore insuring that the tensile failure will occur within the gauge length.

---

<sup>6</sup>Tensile stresses in the lateral direction

<sup>7</sup>Even if tab length is long, the wedge length is longer than the tab length.

- a) The long neck ended shape has a slightly higher ultimate tensile strength [Ref. 4] than the straight-sided, short-tab-ended shape with 30° bevel angle. However there is a big difference in ultimate tensile strength between a 30° bevel angle (see Appendix A) specimen and a 10° bevel angle<sup>4</sup> specimen. Scaling down the specified dimensions without performing an experiment is risky.
- b) The principle behind the streamline shape is in the tradition of the use of analogies between hydraulic flow and elastic stress fields in bodies of comparable shape. This has been described from time to time in the literature [Ref. 13] and [Ref. 14] as a means of designing machine parts having low stress concentration factors. In the present case, the specimen shape, derived from one of the flow lines for the system shown in Figure 4.2, represents two-dimensional flow in a channel with an abrupt right-angle expansion. Without the solution of the flow field, i.e., the shapes of the flow lines, streamline shaped test specimens of the composite materials can not be used.
- c) Specimens in Figure 4.1.C and 4.1.D are not widely used for the tensile test specimens of composite materials, and therefore results for these shapes are rare.
- d) Specimens in Figure 4.1.C and 4.1.D are cross-ply laminate. There is a difference in stress fields and characteristics between cross-ply (Figure 1.1.A) and woven-style (Figure 1.1.B) composite materials.
- e) The conventional ASTM dogbone specimen shown in Figure 4.1.A obviously can not be used to determine the ultimate tensile strength and elastic modulus of anisotropic materials<sup>5</sup> [Ref. 2], because typical failure occurs away from the uniform-cross-section region in the center of the specimen. This is believed to give low ultimate tensile strength values that do not accurately characterize the material under test [Ref. 11].

---

<sup>4</sup>The 10° bevel angle specimen is greater in ultimate tensile strength than the 30° bevel angle specimen.

<sup>5</sup>An anisotropic body is one for which the properties at a point depend upon the orientation at the point. An isotropic material has material properties that are the same in every direction at a point in the body, i.e., the properties are not a function of orientation at a point in the body.

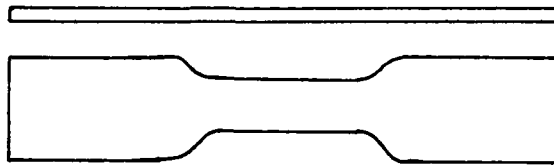

A. ASTM Dogbone

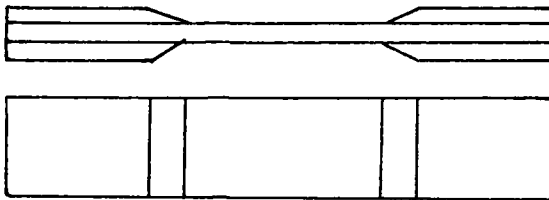

B. Straight-Side Tab Ended

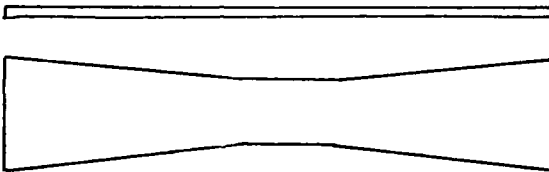

C. Long Necked (Bowtie)

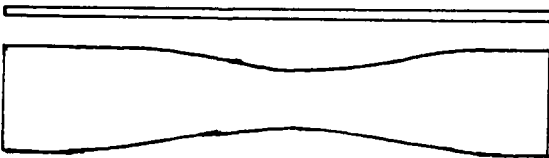

D. Stream Line

Figure 4.1. Tensile Testing Specimen's Shape

#### IV. DESCRIPTION OF THE SPECIMENS

##### A. SPECIMEN SHAPE

The physical shape of the tensile test specimen for this investigation was the result of three considerations:

- a) To get the highest ultimate tensile strength.
- b) To insure that the tensile failure occurs in the middle of the specimen.
- c) To insure that the specimen will fit inside the constant temperature zone of the furnace.

Generally tensile test specimen shapes of composite material at elevated temperature can be classified as ASTM dogbone, straight-side tab-ended, long-necked, and stream-line shape as shown in Figure 4.1.

Dastin S. et al [Ref. 4] recommended that the long necked specimen with 2.7% taper as shown in Figure 4.1.C to get the highest ultimate tensile strength and failure within the gauge length.

Donald W. Oplinger et al [Ref. 11] recommended the stream-line specimen shape shown in Figure 4.1.D to get the highest ultimate tensile strength, and to eliminate failure due to shear stress and tensile stress concentrations.

Although these authors recommended these particular specimen shapes; for this investigation straight-side, the long tab-ended (with 10° bevel angle) specimen shape (see Appendix A) was used for the following six reasons:

### III. OBJECTIVES AND SCOPE OF THE TEST PROGRAM

#### A. OBJECTIVES OF THE TEST PROGRAM

The objective of this investigation was to determine the change of the ultimate tensile strength and elastic modulus of HMF 330/34 woven-style graphite epoxy eight<sup>3</sup> plied exposed to the temperatures: 16°C (58°F), 50°C (122°F), 80°C (176°F), 110°C (230°F), 140°C (284°F) and 170°C (338°F).

#### B. SCOPE OF THE TEST PROGRAM

The particular choice of three different types of eight layer with  $(0/+45/-45/90)_S$ ,  $(+45/0/-45/90)_S$ ,  $(+45/90/-45/0)_S$  orientation was the result of three considerations:

- a) These are universally employed and easily duplicated layups.
- b) Using eight layers produce a laminate of significant strength. The high strength permits high test loads, which in turn reduce the magnitude of potential experimental errors, such as small load fluctuations, in relation to the total load. This reduction of the error has obvious benefits for the accuracy of the experiment [Ref. 10].
- c) According to the layup sequence, the ultimate tensile strengths are different [Ref. 11] and the design of the laminate itself strongly influences the load transfer [Ref. 12].

---

<sup>3</sup> $(0/+45/-45/90)_S$ ,  $(+45/0/-45/90)_S$ ,  $(+45/90/-45/0)_S$ .

90 percent. His composite material consists of Thermal 300/  
Fiberite 1034 graphite epoxy composite using 0°, 45°, and  
90° layup sequences.

but for 90° laminates there was a significant decrease in ultimate tensile strengths in the temperature range from 107°C (225°F) to 177°C (350°F). His composite material consists of Thermal 300/fiberite 1034 graphite epoxy composite using 0°, 45°, and 90° layup sequence. Finally he commented that the effects of temperature on the ultimate tensile strength depends on lay-up sequence.

Studies by R.N. Hadcock et al [Ref. 7] have found that the ultimate tensile strength increases as the temperature increases and failure occurred predominantly outside the tab region in the temperature range from -55°C (-67°F) to 127°C (260°F), but for temperatures above 177°C (350°F) the ultimate tensile strength decreases and the failure occurred within the tab region. His composite material consists of unidirectional Narmco 5505 boron-epoxy system.

Studies by D.A. Meyn et al [Ref. 8] have found that ultimate tensile strength decreases and elastic modulus increases slightly from 24°C (75°F) to 121°C (250°F). His composite material consists of graphite epoxy 8 layer cross-ply sheet in the (45/-45/0/90)<sub>s</sub> orientation.

Studies by S.W. Tsai [Ref. 9] have found that for 90° laminates, an increase in temperature causes a decrease in the elastic modulus. The decrease in the elastic modulus depends upon both the temperature and the moisture content. For an increase in temperature from 27°C (81°F) to 177°C (351°F), the elastic modulus may decrease by as much as 50 to

## II. RECENT RESEARCH

When the recent research into the tensile strength and elastic modulus of composite materials was reviewed, little could be found in the area of the effects of temperature.

Studies by S. Dastin [Ref. 4] has found that the ultimate tensile strength increases up to 232°C (450°F) for the woven style 7781-550 fiber glass reinforced F-161 epoxy-novolac.

Studies by R.Y. Kim et al [Ref. 5] have found that the ultimate tensile strength increases as the temperature increases from room temperature up to 182°C (360°F), but the ultimate tensile strength decreases as the temperature increases above 182°C (360°F). His composite material consists of quasi-isotropic<sup>1</sup> laminates in the orientation (0/+45/-45/90)<sub>s</sub> and were fabricated from Hercules' AS/4501-5 graphite/epoxy system.

Studies by Tsai [Ref. 6] have found that for 0° and 45°<sup>2</sup> laminates, there was no change in the ultimate tensile strength in the temperature range from 107°C (225°F) to 177°C (350°F),

---

<sup>1</sup>The term quasi-isotropic is used to describe laminates that have originally isotropic extensional stiffness (the same in all directions). The simplest example of a quasi-isotropic laminate is a three-ply with a (-60/0/60) stacking sequence. The next simplest example is a four ply laminate with a (0/-45/+45/90) stacking sequence.

<sup>2</sup>0° and 45° means the angle between two adjacent laminar of the composite laminate.

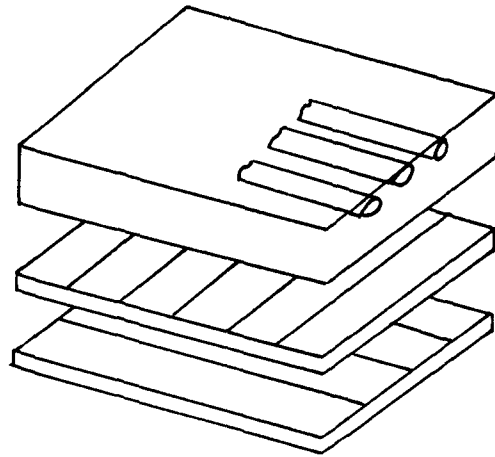

A. Cross-Ply Laminate

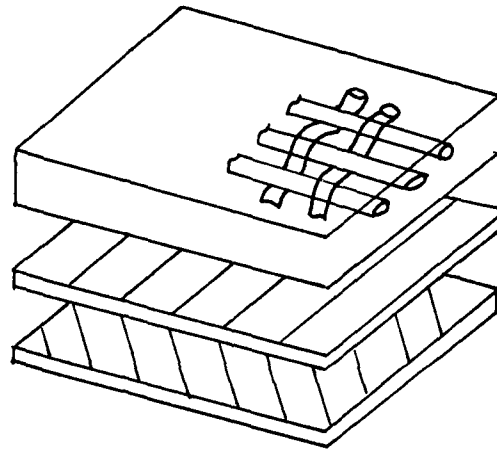

B. Woven-Style Laminate

Figure 1.1 Cross and Woven Type Laminates

a significant increase in the strength-to-weight ratio over common materials. This is the primary reason for using composite materials [Ref. 3].

The material properties of composite materials may suffer when the material is exposed to high temperature. Therefore, in order to utilize the full potential of composite materials, their performance at elevated temperatures must be known.

The purpose of this investigation was to evaluate the changes in the ultimate tensile strength and the elastic modulus of composite material HMF 330/34 woven style graphite epoxy exposed to temperatures from room temperature to 170°C (338°F).

Figure 1.1 shows lamina layup to form a laminate for lamina with unidirectional fibers and woven fibers. A lamina with fibers in one direction is called a unidirectional lamina. A lamina with weave geometry in two directions is called a woven lamina.

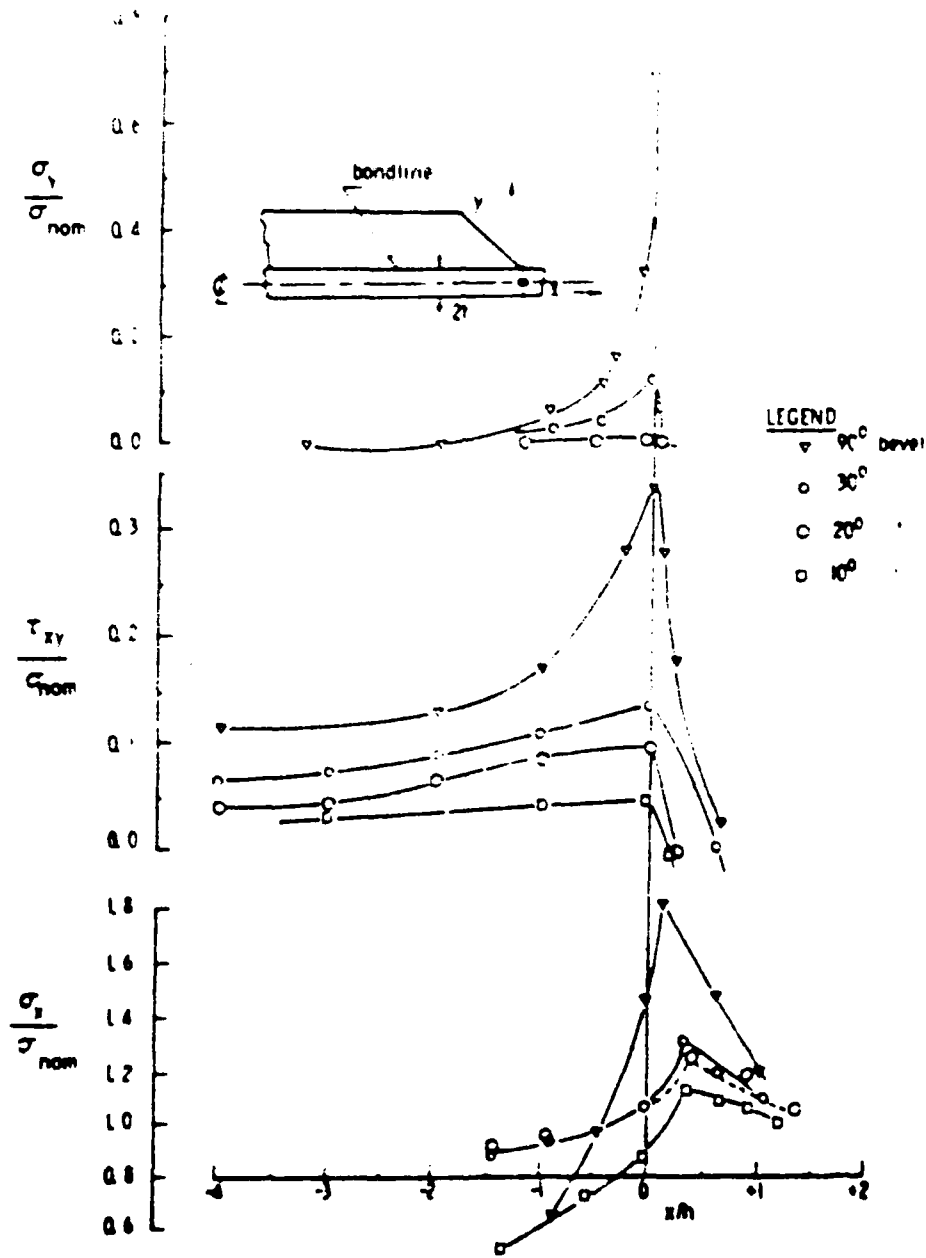

Figure 4.6 Theoretical Stresses in Tabbed Specimens

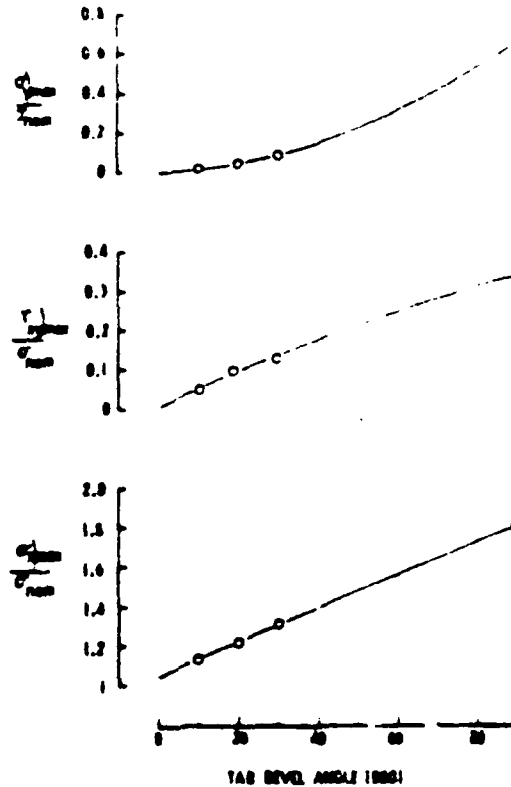

Figure 4.7. Peak Stress vs Tab Angle

temperature. The constant temperature distribution zone of the Marshall furnace extends 4 inches to 4.5 inches in either direction from the center of the furnace [Ref. 17]. Since the grip should also be within the constant temperature zone, the length of the specimen was chosen to be 7.0 inches.

- b) A large aspect ratio (length/width > 10.0) can develop a fairly uniform stress field at the midsection of the specimen [Ref. 18]. Earlier tensile test specimen dimensions of composite materials at elevated temperatures, listed in Appendix B, show aspect ratios from 8.0 to 15.0.

- c) The maximum force that can be obtained from the test equipment<sup>8</sup> is 20,000 lb. (The 10,000 lb load cell was actually used.)
- d) The clear hole diameter of the Marshall furnace is 3.0 inches.

The dimensions of the specimen for this investigation was determined as shown in Figure 4.8. A fairly good aspect ratio of approximately 9.4 was achieved.

#### C. MANUFACTURE OF SPECIMEN AND SPECIMEN IDENTIFICATION

The specimens used in this investigation were manufactured (see Appendix C for more detailed information about the manufacturing of the specimens) in the Lockheed Missiles and Space Company, Inc. The specimens identification are as shown in Table I.

---

<sup>8</sup>Instron Universal Testing Instruments Floor Models TT-D

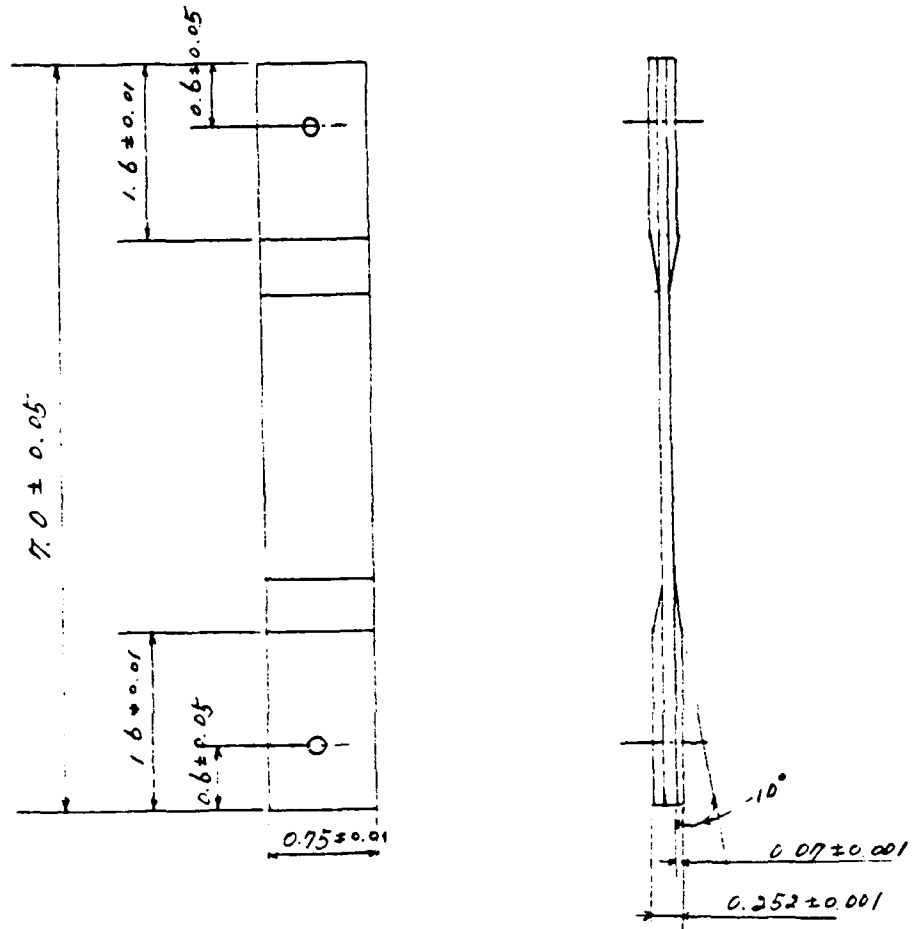

Dimension
1 = 7.00
2 = 0.75
3 = 0.110
Unit = inches
Scale = None
Material = HMF 230/34
Woven Graphite
Epoxy

Figure 4.8 Specimen Dimension

TABLE I  
Specimen Identification

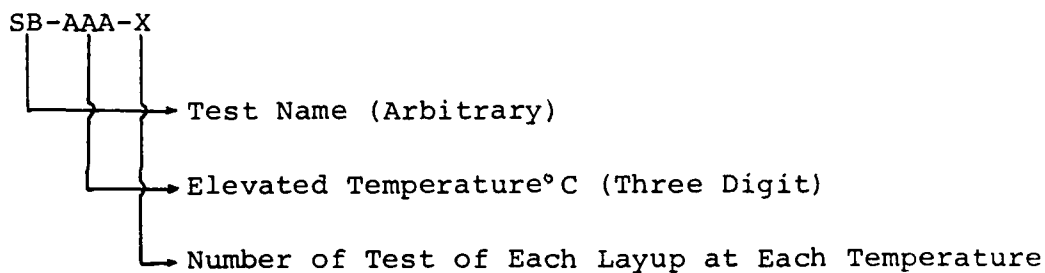

## V. EXPERIMENTAL PROCEDURES

### A. TESTING EQUIPMENT

An Instron universal testing machine, floor model TT-D, with 20,000 lb maximum load capacity, was used to apply the uniaxial tensile loading to the experimental specimens. The original wedge coupling<sup>9</sup> available failed to grip these specimens and had to be abandoned in favor of a new design wedge coupling system, which is described in detail in Appendix D. Also, pull rod series 4043 type 9 inches in length (specially manufactured by the Applied Test System, Inc., Butter, Pennsylvania), were used to pull a specimen at elevated temperatures.

A Marshall model 2232 three-zone clamshell furnace was used for maintaining the elevated temperatures. The temperature in the furnace was controlled by three separate controllers, one for each zone as shown in Figure 5.1. The thermocouples for the furnace controllers were passed into the furnace utilizing a ceramic thermocouple sheath. The controller thermocouple for the upper zone of the furnace was located 6 inches above the thermocouple entrance port and approximately 0.5 inches from the furnace elements. The controller thermocouple

---

<sup>9</sup>Wedge coupling series 4053A with specimen thickness range 0.234 to 0.266 inch type wedge manufactured by Applied Test System, Inc., Butter, Pennsylvania. These wedge couplings were fabricated of Inconel 718 specially for use at elevated temperatures.

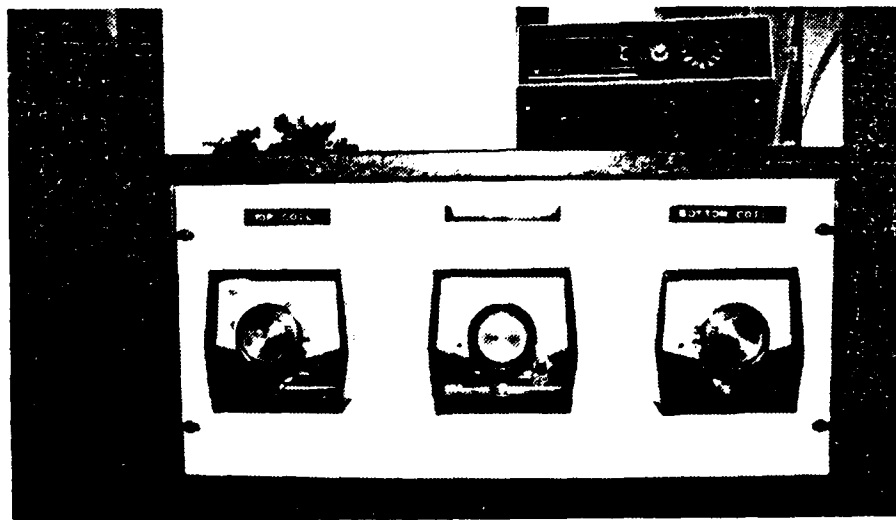
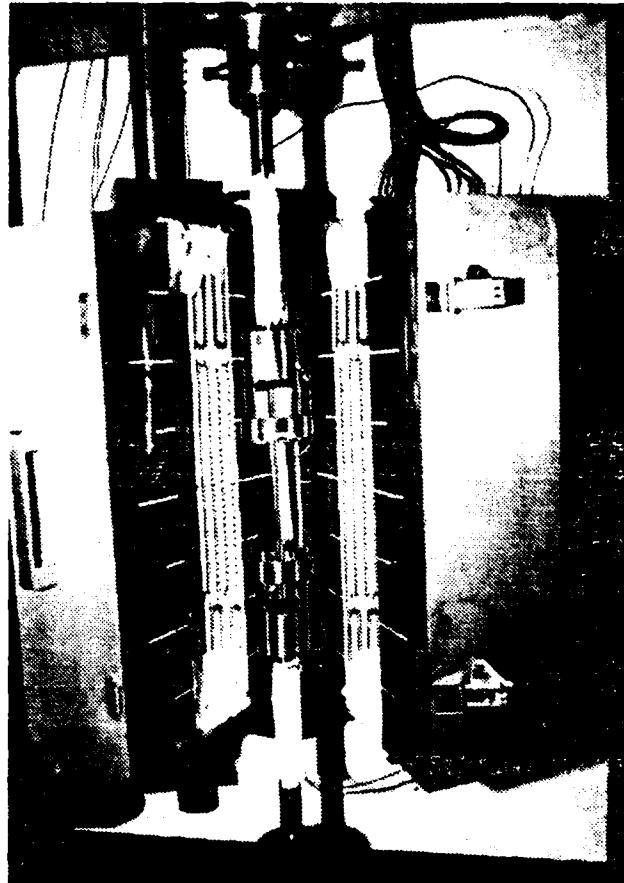

Figure 5.1. Placement of Thermocouples and Controller

for the bottom zone of the furnace was located in a corresponding location below the thermocouple entrance. The controller thermocouple for the center zone of the furnace was located 0.5 inches directly inside the furnace at the thermocouple entrance.

Insulation was installed at several locations both inside and outside of the furnace. Glass insulation of one inch thickness was utilized for the insulation. Thin strips of insulation were placed on the closing surfaces of the furnace. These strips were found to be especially important in obtaining and maintaining uniformity of temperature in the test zone. A thermal pad was placed over the top of the surface. Each of the pull rods were wrapped with insulation in the areas external to the furnace.

The temperature in the furnace was detected by three separate thermocouples as shown in Figure 5.1. One thermocouple was placed 1.4 inches above the middle of the specimen. Another thermocouple was placed 1.4 inches below the middle of the specimen. The third thermocouple was placed on the middle of the specimen. During the test, the furnace temperature was held to within two degrees of the desired temperature. At a desired temperature of 50°C, the specimen had the following temperature distribution over the specimen length: 49°C, 51°C, and 51°C.

## B. EXPERIMENTAL PROCEDURE

In order to check moisture content of specimens, all specimens were stored in three vinyl bags to protect the specimens from moisture absorption from the atmosphere.

Bringing the specimen to the selected testing temperature proceeded as follows: After the specimen was mounted in the grips, it took five minutes to bring the furnace up to the specified temperature. Another five minutes was permitted to elapse to assure that the specimen achieved the furnace temperature. Then the testing was permitted to proceed. The strain rate for this investigation was  $1.0 \times 10^{-4}$  in/in  $\times$  sec as shown in Appendix E.

Before loading, the wedge and specimen were aligned<sup>10</sup> vertically and horizontally with the grip. The presence of out-of-plane bending (see Figure 5.2) in specimens, resulting from misalignment of grips, significantly increase the peak stresses over those obtained for pure tensile load [Ref. 16].

After a test, the connecting pins were either bent or broken.<sup>11</sup>

---

<sup>10</sup>The connecting pin between the wedge and the specimen will break if pin and pulling rod are not properly aligned and strongly tightened.

<sup>11</sup>A steel hammer was used to remove the broken specimen from the grip. Wedges of the lower grip were hit by a hammer to bring the wedge and grip to the same level. After that, the lower collar was hit by the hammer and the lower broken part of the specimen was removed from the grip. The same procedure was used to remove the upper broken part of the specimen from the upper grip.

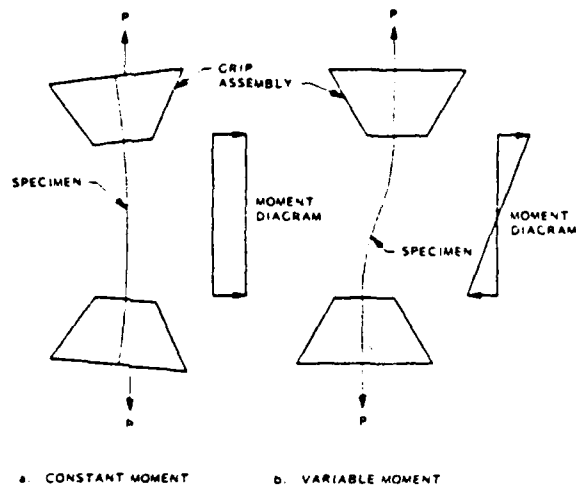

Figure 5.2. Out-of-Plane Bending of Tension Specimens

As strain gauges were not used for this investigation, specimen elongation was obtained by checking the length between gauge marks. White typewriter ink was used to undercoat the gauge mark area. After it dried, a fine black magic pencil was used to mark the gauge length on the specimen as shown in Figure 5.3.

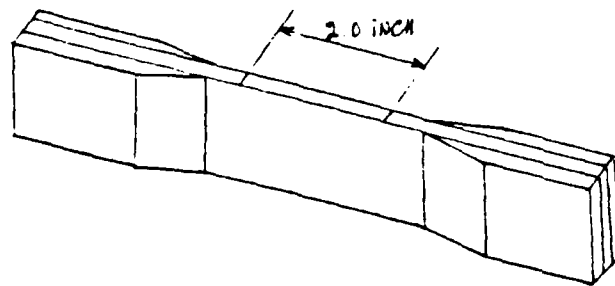

Figure 5.3. Gauge Mark

Checking the final elongation of a specimen at one specified temperature proceeded as follows:

- a) Before loading, the initial gauge length was checked.
- b) The gauge length was checked at three intermediate loads: 1,500 lb, 3,000 lb, and 4,500 lb in the case of failure occurrence at 5,000 lb.
- c) The final elongation (total elongation) was obtained by best fitting a curve through the three load points.

## VI. ANALYSIS

### A. ULTIMATE TENSILE STRENGTH

Ultimate tensile strength was taken as the average of four tests of a layup at one specified temperature. Equation 6.1 was used to calculate ultimate tensile strength.

$$\sigma = \frac{p}{w \times t} \quad (6.1)$$

where:

- $\sigma$  = ultimate tensile strength (psi);
- $p$  = applied force (lbf);
- $w$  = specimen width (inches);
- $t$  = specimen thickness (inches).

### B. ELASTIC MODULUS

Elastic modulus was taken as the average of two of the above four specimens used for measuring ultimate tensile strength. Equation 6.2 was used to calculate elastic modulus.

$$E = \frac{\sigma}{(\Delta/\ell)} \quad (6.2)$$

where:

- $\sigma$  = the value obtained from Eq. 6.1 (psi);
- $\Delta$  = final elongation (inches);
- $\ell$  = initial gauge length (inches).

## VII. EXPERIMENTAL RESULTS

The data obtained in this investigation may be found in Appendix F for ultimate tensile strength and elastic modulus.

The ultimate tensile strengths obtained from this data are plotted in Figures 7.1-7.4. For the #1 panel (0/45/-45/90)<sub>s</sub>, the ultimate tensile strength decreases slightly with temperature up to 140°C (284°F). For the #2 panel (45/0/-45/90)<sub>s</sub>, and #3 panel (45/90/-45/0)<sub>s</sub>, the ultimate tensile strength increases slightly with temperature up to 110°C (230°F). The ultimate tensile strength of the three different panels decreases rapidly with temperature above 140°C (284°F).

The elastic moduli obtained from this data are plotted in Figures 7.5-7.8. The elastic modulus decreases with increasing temperature independent of layup sequence.

The specimen weight checked immediately after receiving specimens from Lockheed Missiles and Space Company, Inc., and just before testing, may be found in Appendix G to check the moisture content.

Each fiber failure was accompanied by audible cracking, beginning at approximately 2,500 lbf with increasing intensity and frequency thereafter up to final failure. After each fiber broke, there was an instantaneous slight decrease in the load, followed by reloading as shown in Figure 7.9.

Failure locations and shapes during this investigation can be generally described as follows:

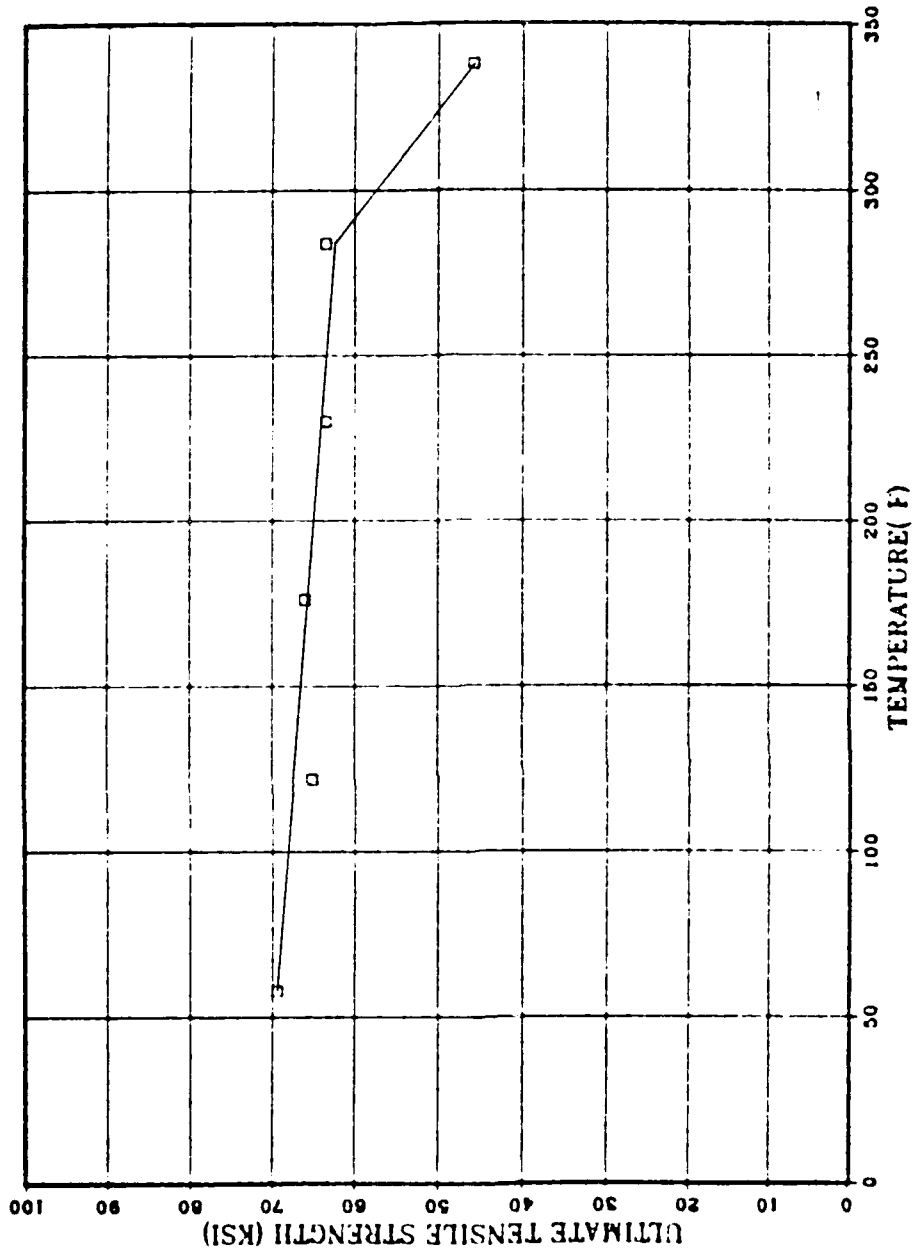

Figure 7.1 Ultimate Tensile Strength vs Temperature of #1 Panel (0/45/-45/30)<sub>s</sub>

## VIII. CONCLUSIONS AND RECOMMENDATIONS

### A. CONCLUSIONS

The data obtained with HMF 330/34 woven-style graphite epoxy are presented in Figures 7.4, 7.8, and Appendix F.

#### 1. Ultimate Tensile Strength

In most cases, data values were within 6 percent of the average values as shown in Appendix F. The consistency of data, lack of scatter of data, and accuracy of the experimental results can be compared to the 20-30 percent data scatter of [Ref. 16] and [Ref. 19]. Generally, in the previous investigations, failure seldom occurred in the middle of the specimen of the composite materials [Ref. 16]. Failure occurred most frequently in the middle of the specimen in this investigation. Thus the ultimate tensile strengths obtained in this investigation are more accurate than previous works. Some general observations can be made as follows:

- a) For the #1 panel (0/45/-45/90)<sub>S</sub>, ultimate tensile strength decreases slightly with temperature up to 140°C (284°F), and decreases rapidly after 140°C (284°F).
- b) For the #2 panel (45/0/-45/90)<sub>S</sub>, and the #3 panel (45/90/-45/0)<sub>S</sub>, ultimate tensile strength increases with temperature up to 110°C (230°F). This behavior is most likely due to increased ductility of the matrix, and relieving of the curing<sup>12</sup> stresses. For

---

<sup>12</sup>Curing is the drying, or polymerization, of the resinous matrix material to form a permanent bond between fibers and between laminae. The curing process can consist of applying heat and/or pressure to speed the polymerization process.

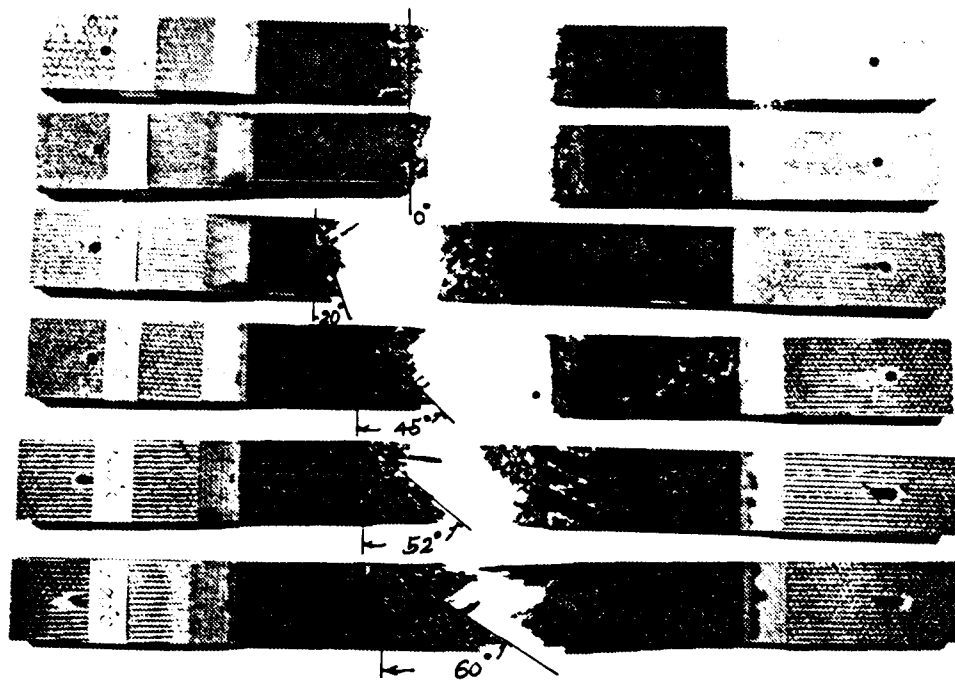

A. Failure Angle vs Temperature



B. Delamination vs Temperature

Figure 7.13. Failure Shape

TABLE II  
Failure Point in  
#1, #2, and #3 Panels

#1 Panel		#2 Panel		#3 Panel	
I.D	Point	I.D	Point	I.D	Point
SB-016-1	T	SB-016-1	LM	SB-016-1	T
SB-016-2	T	SB-016-2	T	SB-016-2	T
SB-016-3	LM	SB-016-3	T	SB-016-3	T
SB-016-4	M	SB-016-4	T	SB-016-4	T
SB-050-1	LM	SB-050-1	T	SB-050-1	T
SB-050-2	M	SB-050-2	T	SB-050-2	T
SB-050-3	M	SB-050-3	LM	SB-050-3	T
SB-050-4	LM	SB-050-4	T	SB-050-4	T
SB-080-1	LM	SB-080-1	T	SB-080-1	T
SB-080-2	AM	SB-080-2	AM	SB-080-2	LM
SB-080-3	LM	SB-080-3	T	SB-080-3	T
SB-080-4	LM	SB-080-4	LM	SB-080-4	AM
SB-110-1	T	SB-110-1	T	SB-110-1	T
SB-110-2	LM	SB-110-2	T	SB-110-2	AM
SB-110-3	M	SB-110-3	LM	SB-110-3	AM
SB-110-4	LM	SB-110-4	LM	SB-110-4	LM
SB-140-1	LM	SB-140-1	M	SB-140-1	M
SB-140-2	AM	SB-140-2	LM	SB-140-2	LM
SB-140-3	AM	SB-140-3	AM	SB-140-3	LM
SB-140-4	M	SB-140-4	LM	SB-140-4	LM
SB-170-1	M	SB-170-1	M	SB-170-1	M
SB-170-2	AM	SB-170-2	M	SB-170-2	M
SB-170-3	AM	SB-170-3	M	SB-170-3	M
SB-170-4	M	SB-170-4	M	SB-170-4	M

Location of Failure  
T : Tab Region  
LM: 1.0 Inch from Middle of Specimen  
AM: 0.5 Inch from Middle of Specimen  
M : Middle of Specimen



#3 p956

Figure 7.12. #3 Panel Failure Location

A. RUPTURE FAILURE SHAPE

- a) At lower temperatures (approximately below  $80^{\circ}\text{C}$  ( $176^{\circ}\text{F}$ )), specimen failure were almost horizontal.
- b) At higher temperatures (approximately above  $110^{\circ}\text{C}$  ( $230^{\circ}\text{F}$ )), specimens failed making  $45^{\circ}$  to  $60^{\circ}$  failure angle as shown in Figure 7.13.A.
- c) The failure angle increases as temperature increases as shown in Figure 7.13.A.
- d) Examination of failed specimens revealed extensive delamination at the elevated temperature as shown in Figure 7.13.B.

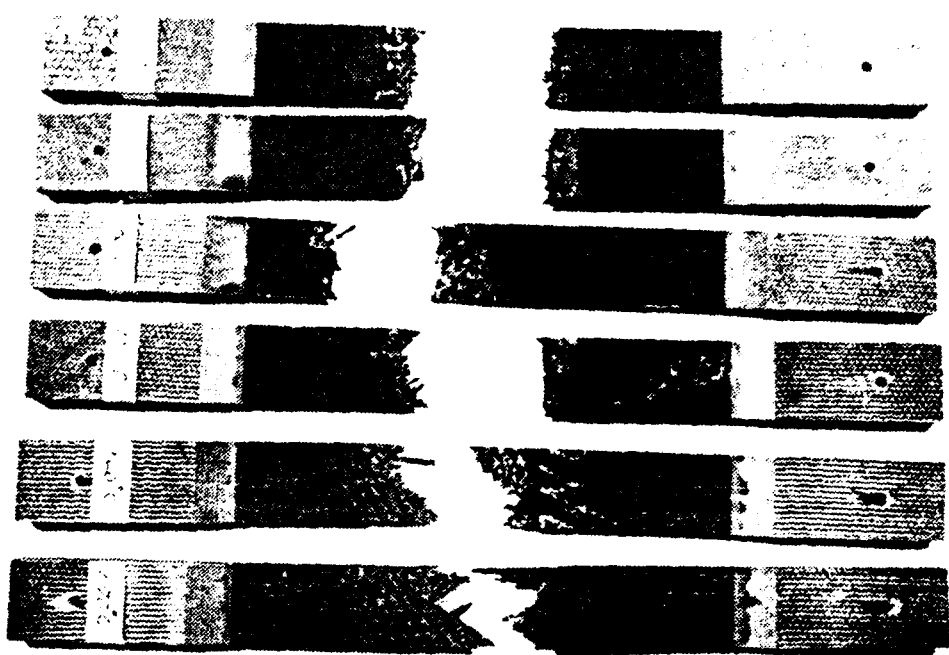

#1 PANEL

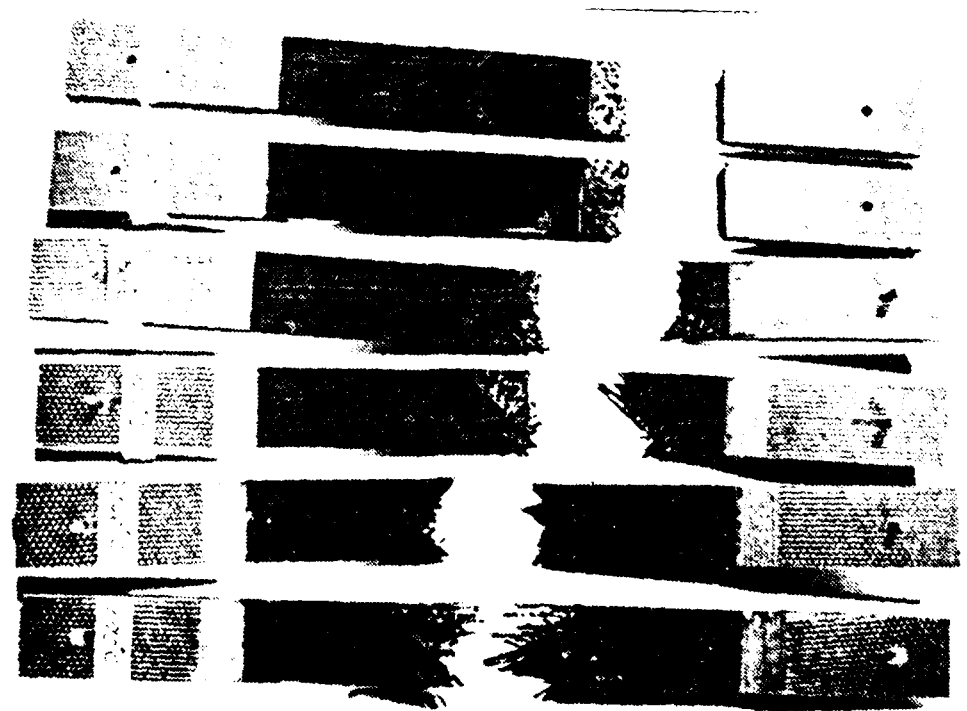

#2 PANEL

Figure 7.11. #1 and #2 Panel Failure Location

- a) At lower temperatures (approximately below  $110^{\circ}\text{C}$  ( $230^{\circ}\text{F}$ )), failure initiated at the tab region, and propagated inside the tab region as shown in Figure 7.10.

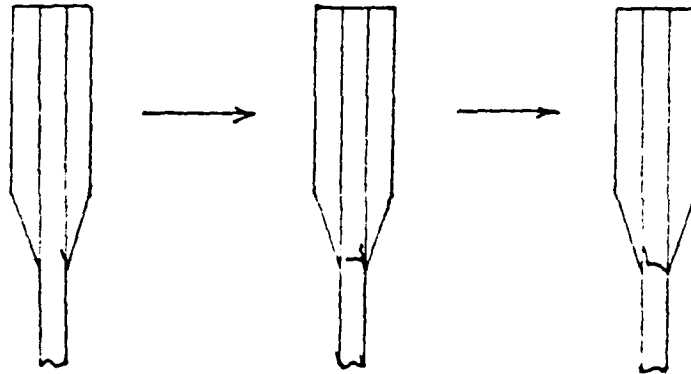

Figure 7.10. Failure at Tab Region

Few specimens debonded between the tab and the main specimen body. Failure was initiated in the same way as previously mentioned.

- b) At higher temperatures (approximately above  $110^{\circ}\text{C}$  ( $230^{\circ}\text{F}$ )), failure occurred in the middle of the specimen.
- c) Failure locations were independent of temperature for the #1 panel. For the #2, and #3 panels, failure locations approached the middle of the specimen as temperature increased as shown in Figures 7.11-7.12.

Table II shows failure locations in the #1, #2, and #3 panels.

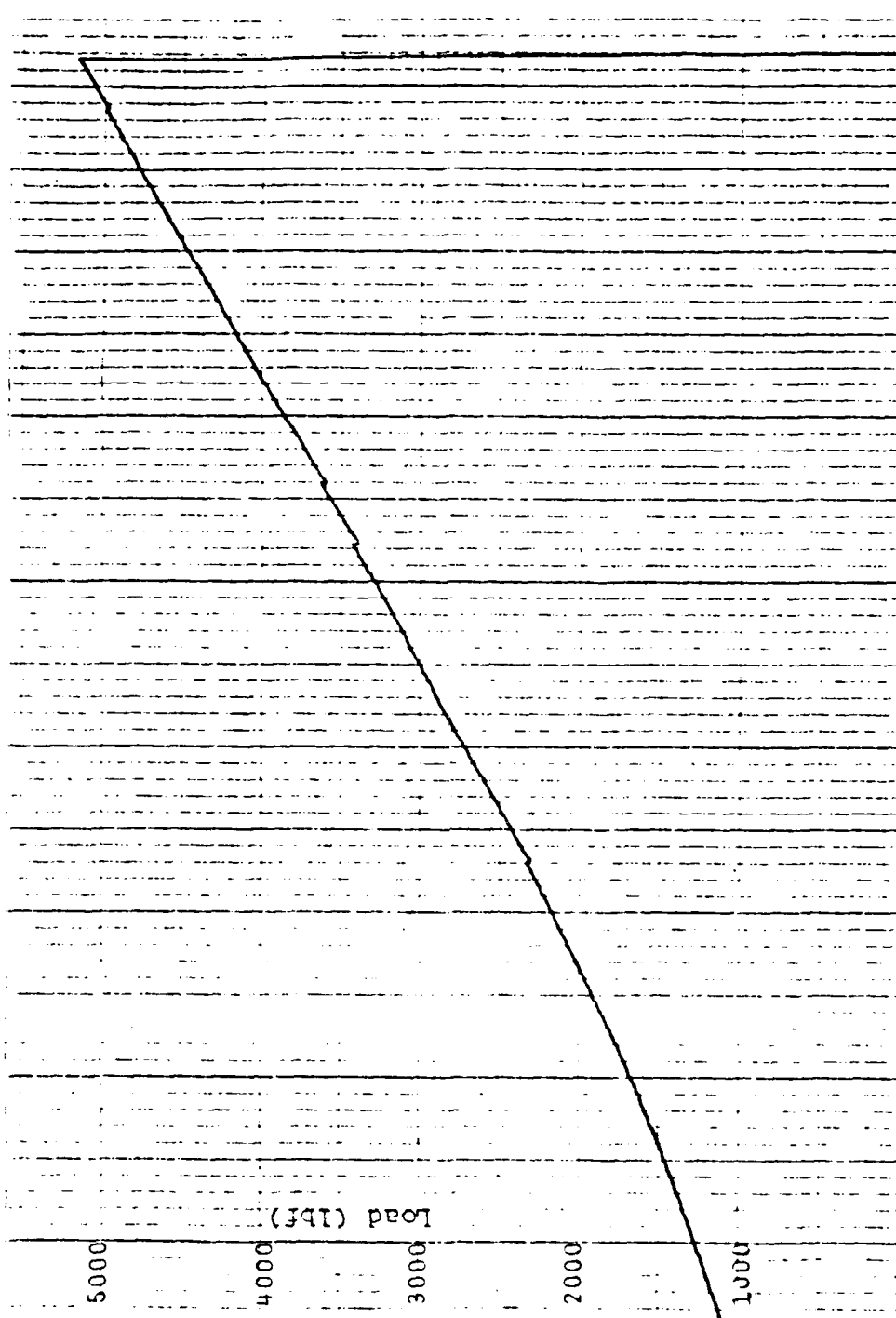

Figure 7.9 Load vs Fiber Broken

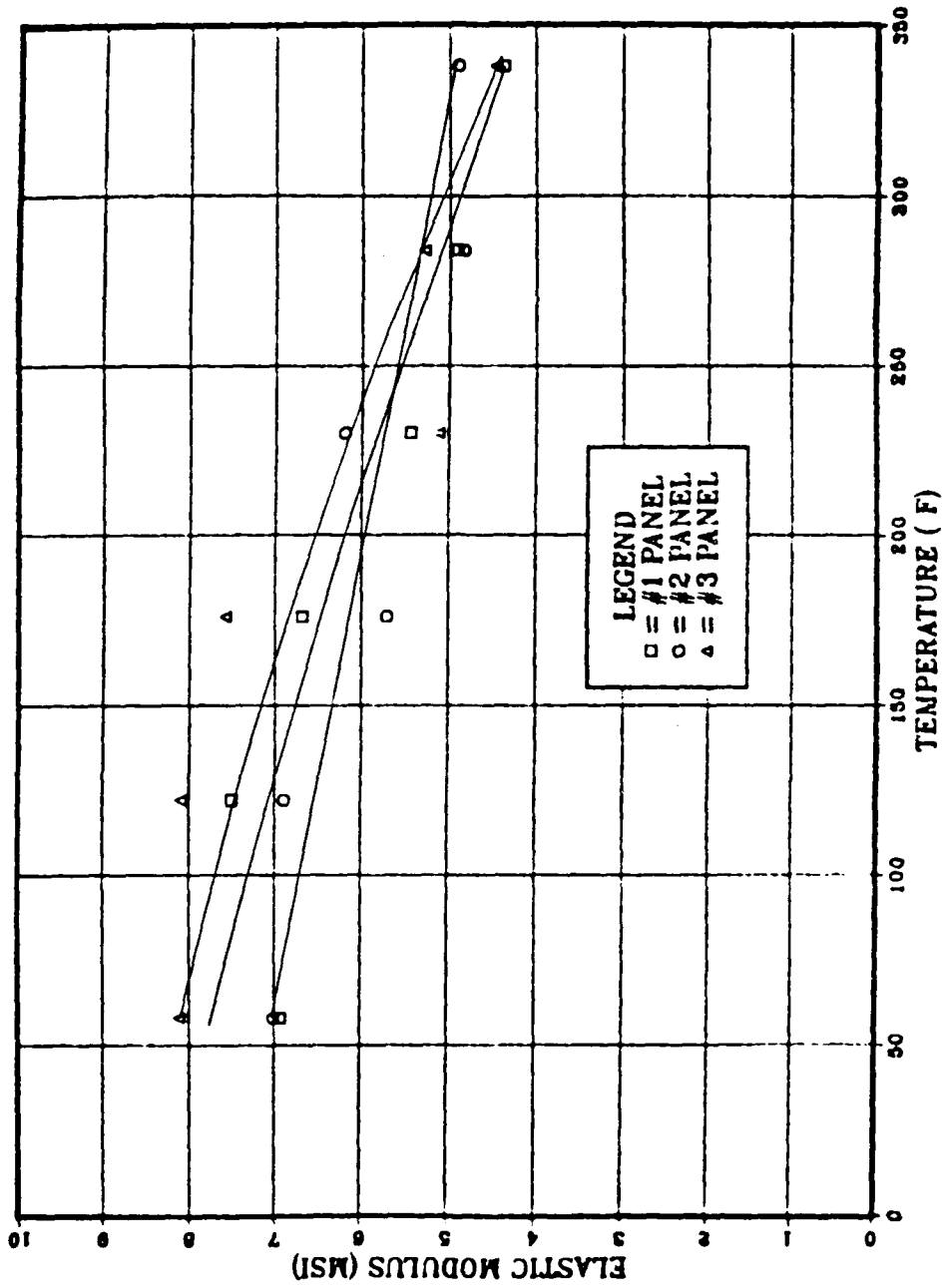

Figure 7.8 Elastic Modulus vs Temperature of #1, #2, and #3 Panel

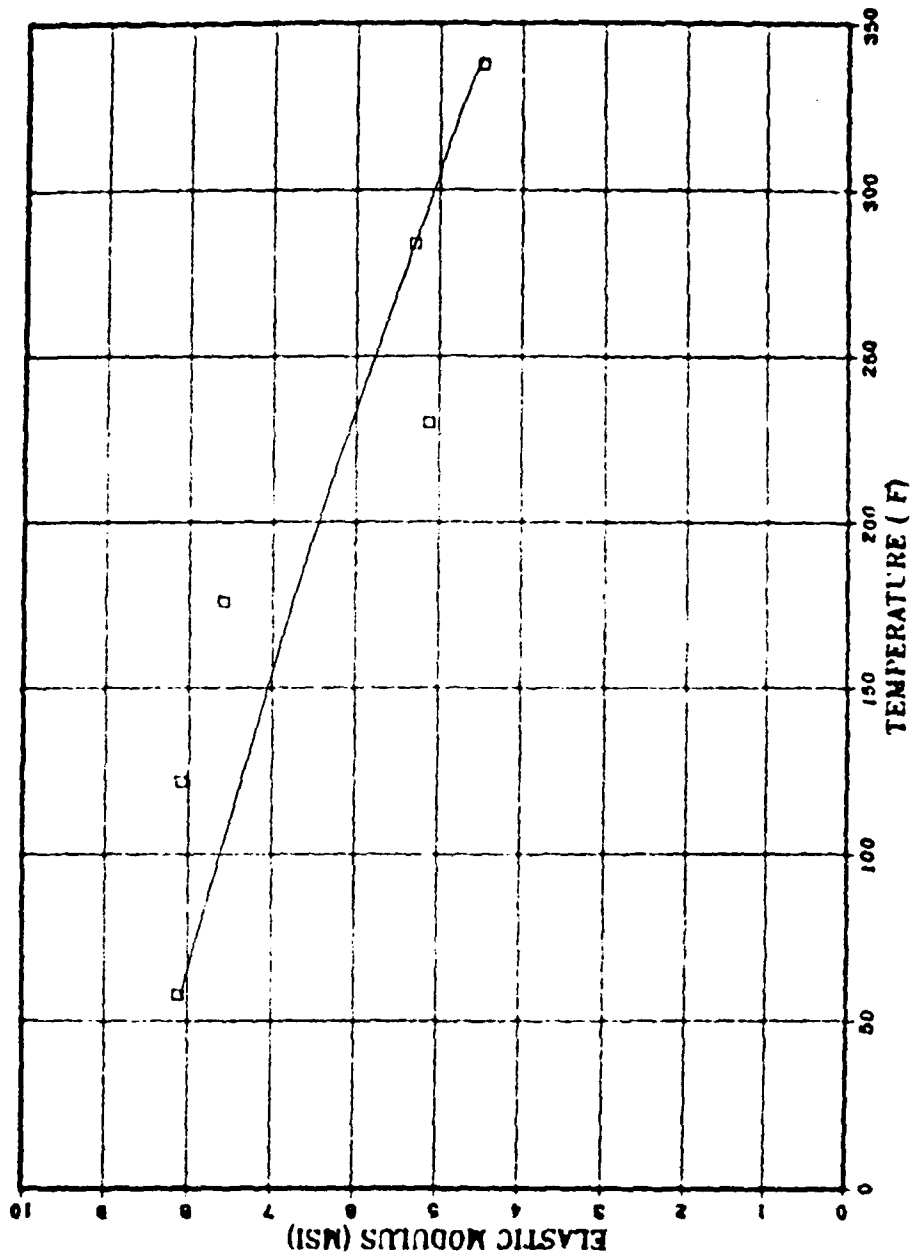

Figure 7.7 Elastic Modulus vs Temperature of #3 Panel (45/90/-45/0)<sub>s</sub>

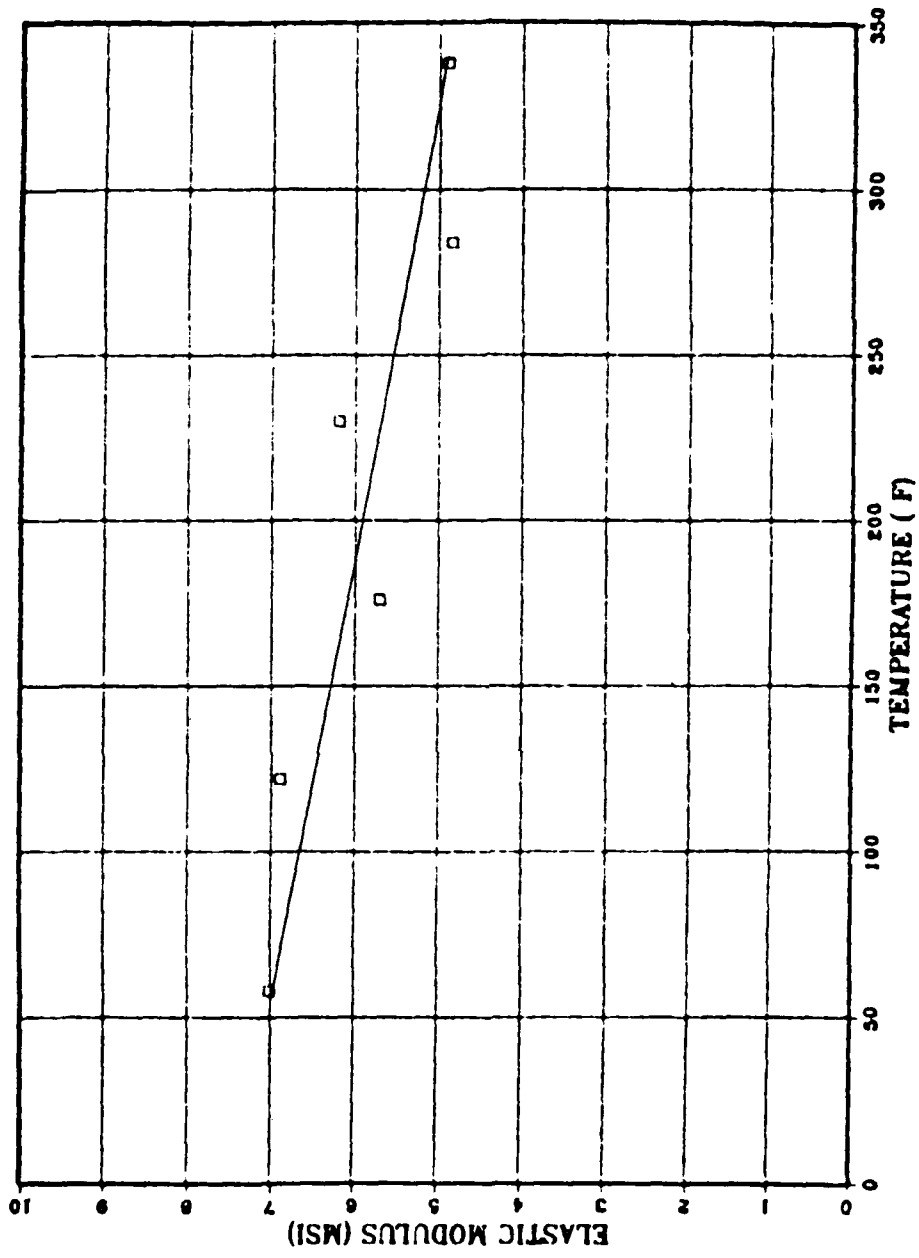

Figure 7.6 Elastic Modulus vs Temperature of #2 Panel (45/0/-45/90)<sub>s</sub>

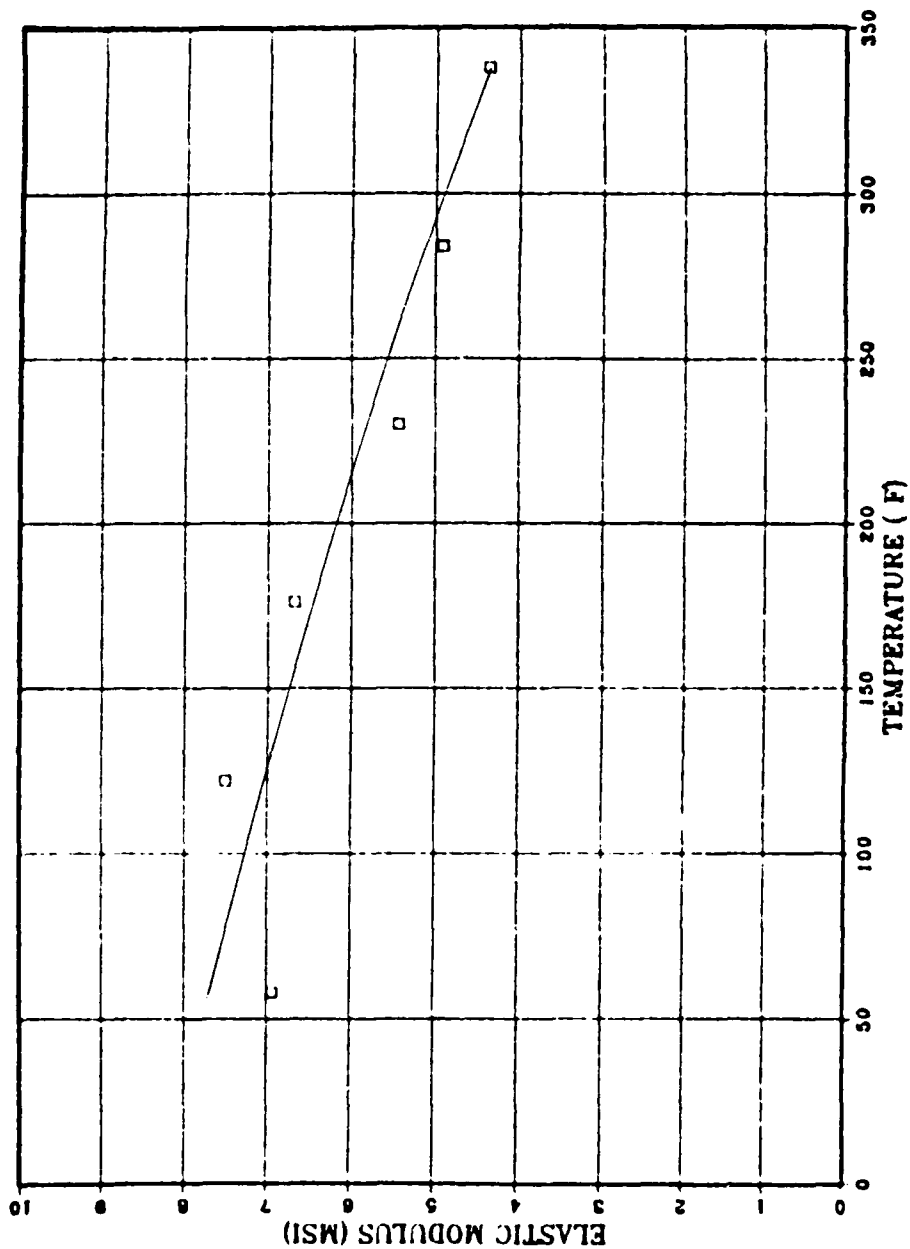

Figure 7.5 Elastic Modulus vs Temperature of #1 Panel (0/45/-45/90)<sub>s</sub>

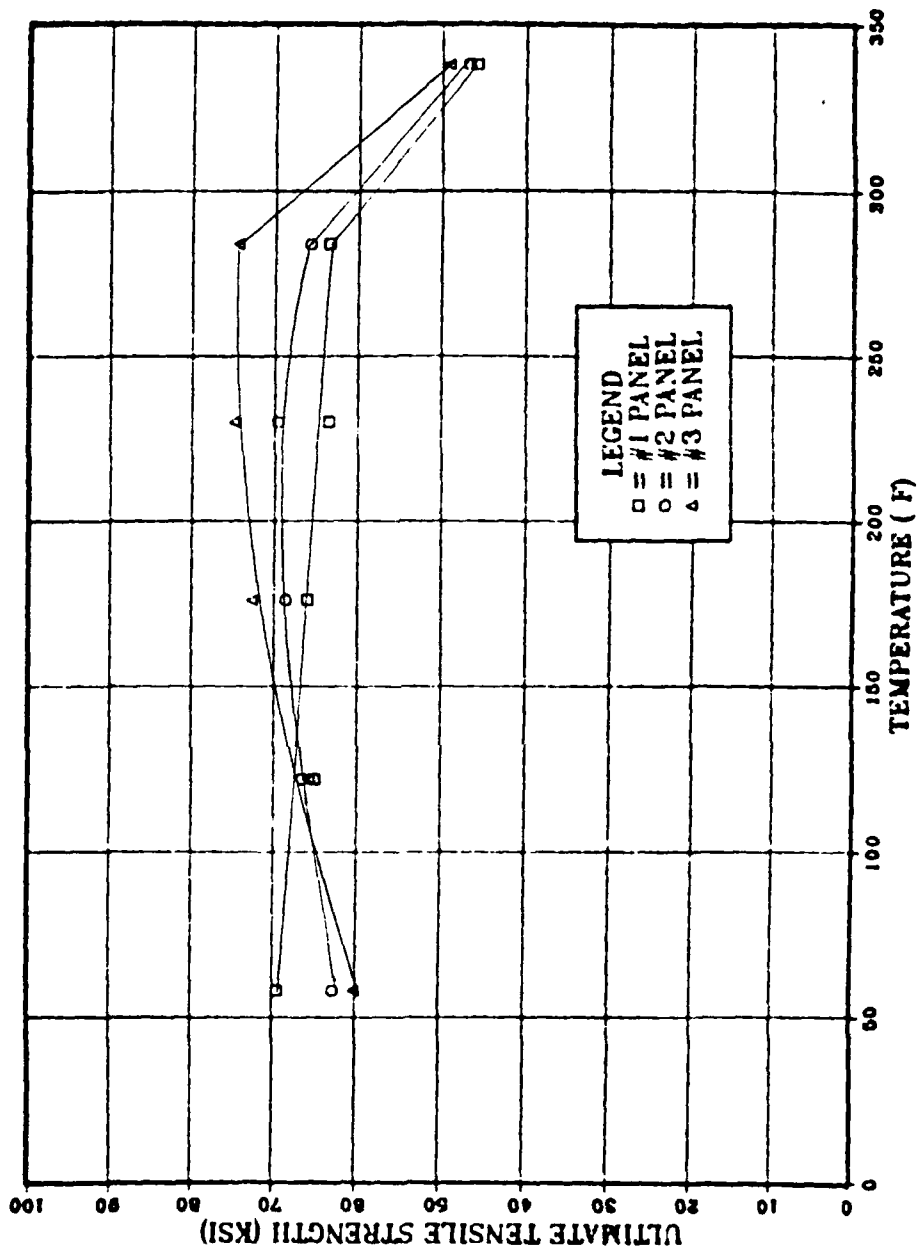

Figure 7.4 Ultimate Tensile Strength vs Temperature of #1, #2, and #3 Panel

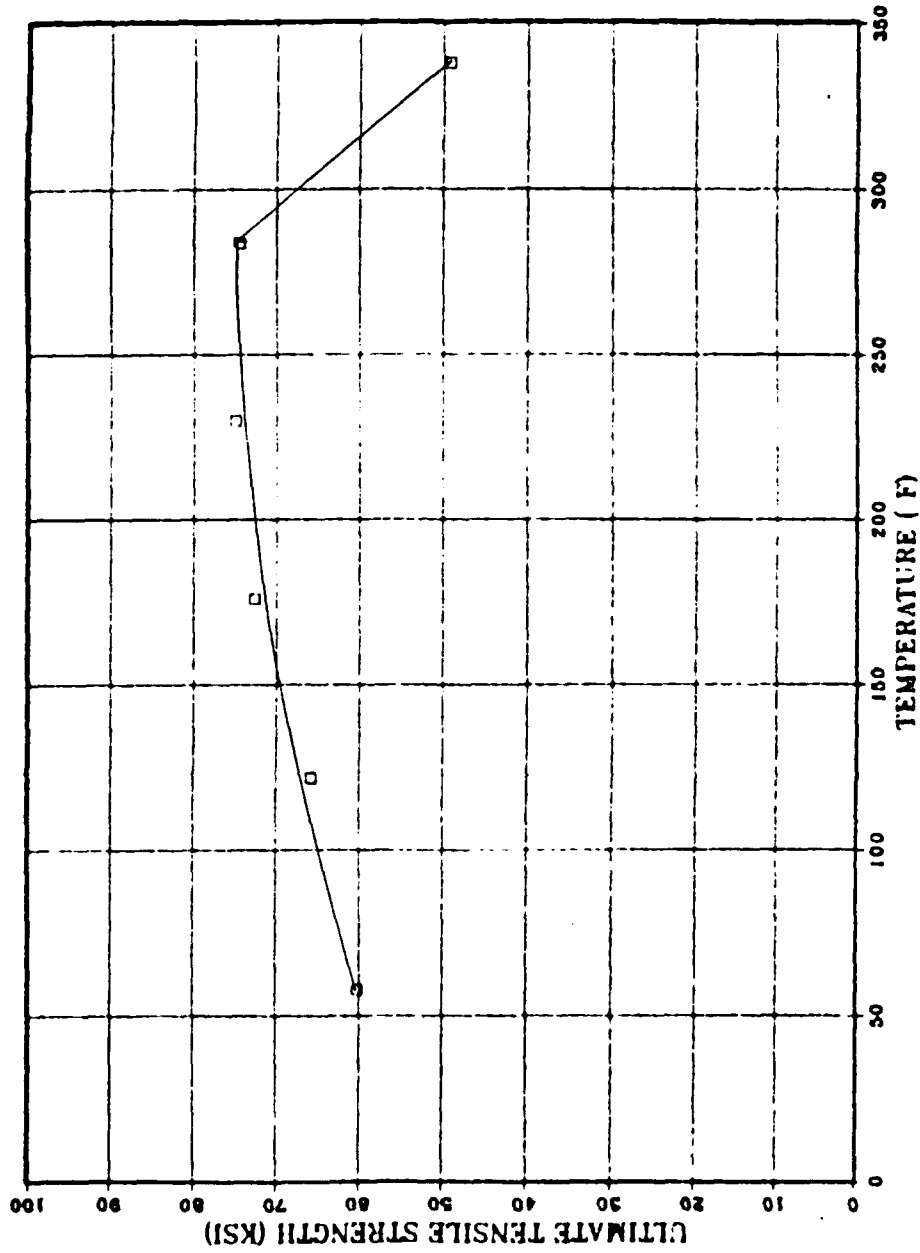

Figure 7.3 Ultimate Tensile Strength vs Temperature of #3 Panel (45/90/-45/0)<sub>s</sub>

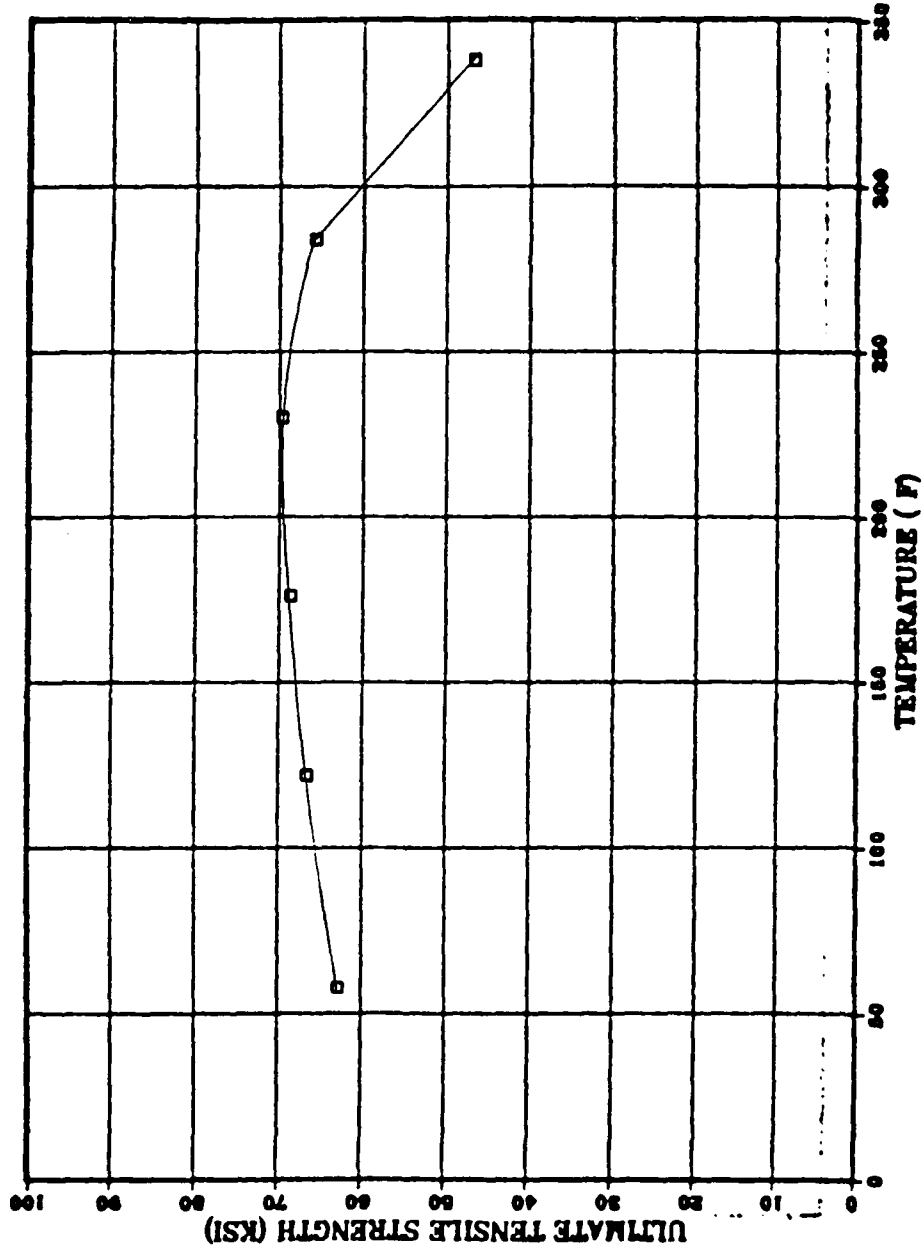

Figure 7.2 Ultimate Tensile Strength vs Temperature of #2 Panel (4S/0/-45/90)<sub>s</sub>

temperatures above 140°C (284°F), the ultimate tensile strength decreases rapidly. These results coincide well with J.M. Whiney results [Ref. 5].

- c) The ultimate tensile strength of the three different panels decreases rapidly with temperatures above 140°C (284°F) due to increasing matrix damage (resin burning) imposed by the high temperatures, as shown in Figures 7.11-7.13.

## 2. Elastic Modulus

In most cases, data values were within 8 percent of the average values as shown in Appendix F. The consistency of data, lack of scatter of data and accuracy of the experimental results can be compared to the 20-30 percent data scatter of previous investigations as noted in [Ref. 6], and [Ref. 19]. The elastic modulus decreases with increasing temperature, independent of layup sequence as shown in Figure 7.8.

## 3. Moisture

The moisture absorption during this investigation is negligible as shown in Appendix G. There was no need to compensate the ultimate tensile strength due to the moisture absorption.

## 4. Failure

As analyzed below, failure occurred almost in the middle of specimens. This suggests accurate ultimate tensile strengths and elastic moduli of the tested materials.

- a) At lower temperatures (approximately below 80°C (176°F)), failure occurred around the tab region except for the #1 panel.
- b) At higher temperatures (approximately above 110°C (230°F)), failure occurred around the middle of the specimen, independent of layup sequence as shown in Table II.

- c) Failures occurred in the middle of specimens independent of temperature for the #1 panel. For the #2, and #3 panels, failure points approached the middle of the specimen as temperature increased. These results coincide well with Murat H. Kural's study [Ref. 16], which showed that failure points depend on the layup orientation.

## B. RECOMMENDATIONS

This section will consist of two parts. In the first part, some recommendations are passed along to assist in any future follow-up research activities. In the second part, several suggestions for any future research activities are presented.

### 1. Recommendations from This Investigation

Firm holding of the specimens within the grips is very important for the tensile testing of the composite materials. From the experience of this investigation, recommendations for firm holding of specimens, follow:

- a) Long and wide wedges provide larger frictional surface between wedge and specimen tab with the same wedge angle.
- b) Wedges longer than the specimen tab protect against debonding between the tab and the main body of the specimen.
- c) Specimens can be firmly held by wedges with large wedge angle. This provides greater frictional surface.

### 2. Suggestions for Future Research Activities

Further research in this area appear to be of significant value.

- a) The strength of the fibers in a composite material does not change with temperature; but the bond strength of the resin (matrix) depends on temperature [Ref. 20]. Therefore it is recommended that composite materials

with different resins be investigated and compared. The purpose of this investigation would be to find the best resin at high temperatures.

- b) This investigation covered temperatures up to 170°C (338°F). It would be useful to test specimens at temperatures above 170°C (338°F). This will provide additional information about the behavior of composite materials in severe thermal environments.

APPENDIX A  
NOMENCLATURE

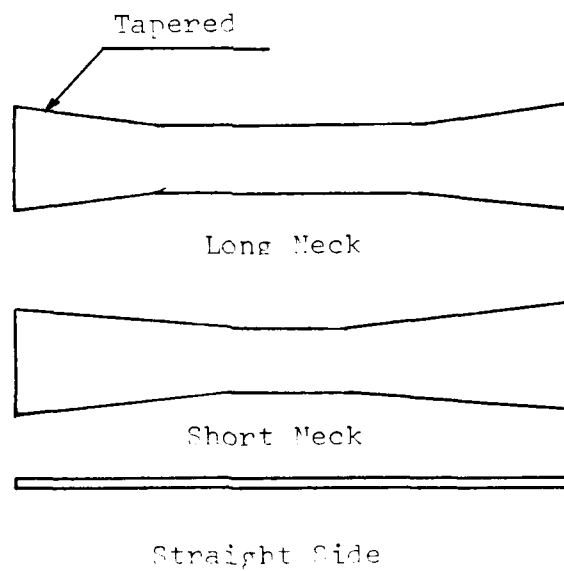
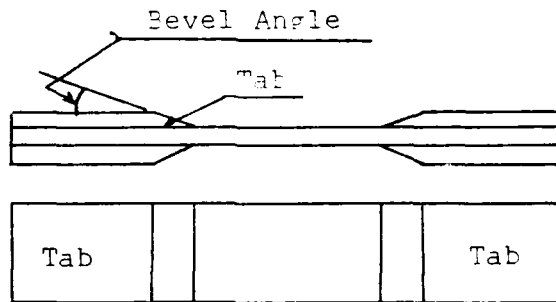

## APPENDIX B

TENSILE TEST SPECIMEN DIMENSION OF COMPOSITE MATERIAL AT ELEVATED TEMPERATURE

TABLE III  
Tensile Test Specimen Dimensions  
of Composite Material at Elevated Temperature

Specimen Dimension (L B T) inch	Testing temperature (°F)	Material	Testing Equipment	Reference
9.0*0.75*0.05	R.T., 260, 350	Boron epoxy (Marmco 5505)	INSTRON	7
10.*0.5*0.08	-65, 75, 450	Woven style 7781-550 fiber glass reinforced F-161 epoxy novolac	Unknown	4
9.0*1.0*0.10	R.T., 360, 400, 450, 500, 550	AS/3501-5 graphite-epoxy (0/+45/-45/90) <sub>s</sub> 8ply	MTS	5
3.97*0.5*0.035	-110 ~ 350	Graphite epoxy thonel 300/ fiberite 1034 0° layup, 45° layup	INSTRON 10900 #	6
10.*0.75*0.135	Unknown	3M's sp 250E (E glass epoxy) (0 <sub>10</sub> /90 <sub>4</sub> ) 14 ply	Unknown	9
5.24*1.0*0.08	R.T., 260	Graphite epoxy thonel 300/ namco 5208 (0 <sub>2</sub> /+45/-45) <sub>2s</sub> (90 <sub>2</sub> /+45/-45) <sub>2s</sub> , (0/+45/-45/90) <sub>2s</sub>	MTS	12
8.5*0.5*0.11	1004, 1400, 1760	Graphite epoxy thonel 300/ fiberite 1034	INSTRON	21
11.*0.75*0.044	75, 250	Graphite epoxy with 60 v/o Hercules type AS graphite in 3501 epoxy matrix 8 ply (+45/-45/0/90) <sub>s</sub>	Closed loop servo controlled hydraulic machine	8

## APPENDIX C

### MANUFACTURING OF SPECIMEN

Specimens used for this investigation were manufactured by Lockheed Missiles and Space Company, Inc. The "exploded" layup of the panels is shown in Figure C.1. The meaning of the nomenclature used in this figure is as follows:

- a) The release film is to ensure the cured laminate does not become bonded to the tool.
- b) TX 1040 separator film ensures that the bleeder cloth can be easily removed from the laminate.
- c) The bleeder cloth absorbs the excess resin flowing out from the layup during cure.
- d) The Celgard microporous film allows the volatiles generated to flow out into the breather but prevents the excess resin from entering the breather.
- e) The breather plies transmit the vacuum pressure differential used to remove the volatiles.

The actual cure cycle of one of the panels is shown in Figure C.2. The three closely spaced dotted lines are the three thermocouples used in the autoclave control. The single irregular dashed line is the autoclave Nitrogen pressure.

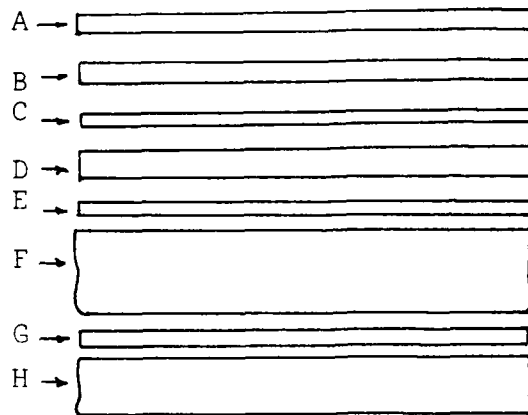

- A: Vacuum bag
- B: 2 Plies breather cloth
- C: Celgard microporous separator ply
- D: 3 Plies bleeder cloth
- E: TX 1040 separator film
- F: 8 Ply graphite/epoxy panel layup
- G: Fep release film
- H: Metal tool

Figure C.1. Exploded Layup of the Panels

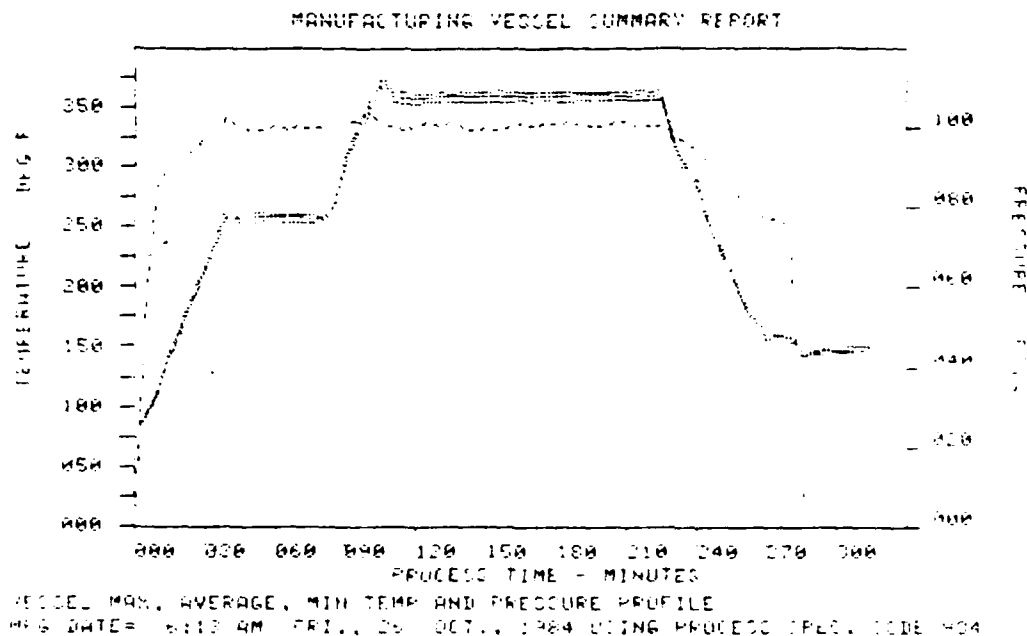

The nominal cure cycle is

- . Heat to 250 F in 45 minutes
- . Hold at 250 F for 45 minutes
- . Heat to 350 F
- . Hold at 350 F for 120 minutes
- . Cooldown

Figure C.2. Actual Cure Cycle of the Specimens

## APPENDIX D

### NEW DESIGN WEDGE COUPLING

The original<sup>13</sup> grip equipment was used for the trial experiment at room temperature. Unfortunately when the load was applied, the wedge and specimen (connected by pin) were released from the wedge coupling due to the following two reasons:

- a) The frictional surface between the wedge and specimen was too small to provide enough frictional force to hold the specimen and wedge within the couplings.
- b) As the fiber-glass tab was compressed during loading, the wedge angles were too small (approximately 3°) to hold the specimen.

The above two reasons were verified by testing a specimen with a larger jaw as shown in Figure D.1. This big jaw could not be used for this investigation, because it's too large to fit inside the Marshall furnace. Finally, a new (modified) wedge coupling system was designed, as follows:

- a) The frictional length between the wedge and specimen was increased from 0.9 inches to 1.7 inches. (This is almost the same length as the big jaw.)
- b) The wedge angle was increased from 3° to 10°. (This is the same as the wedge angle for the big jaw.)

The new design wedge coupling system is shown in Figures D.2-D.4. This new design wedge coupling system was manufactured

---

<sup>13</sup>Wedge coupling series 4053A with specimen thickness range 0.234 to 0.266 inch type wedge manufactured by Applied Test System, Inc., Butter, Pennsylvania.

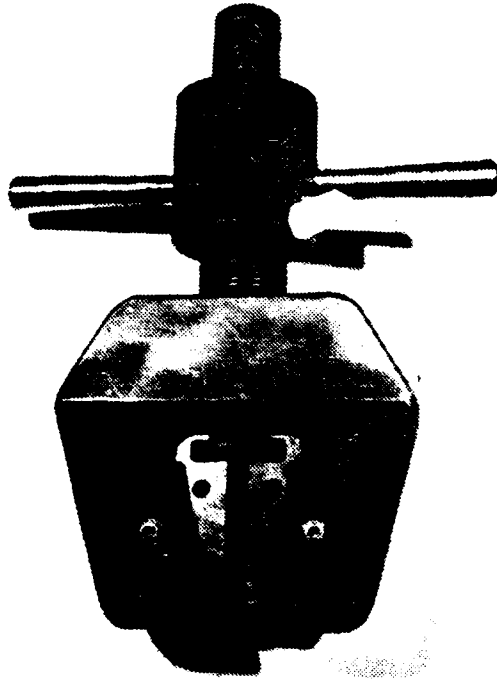

Figure D.1. Big Jaw Configuration

by machinists in the Mechanical Engineering Department of  
the Naval Postgraduate School.

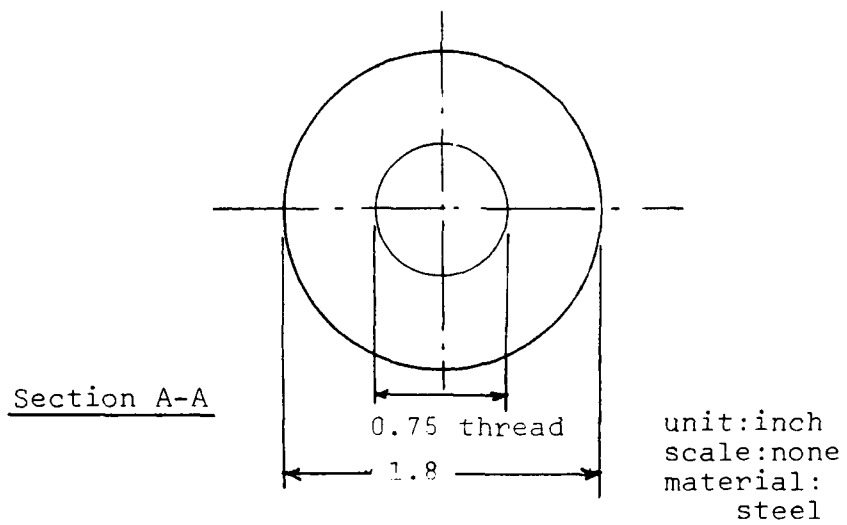
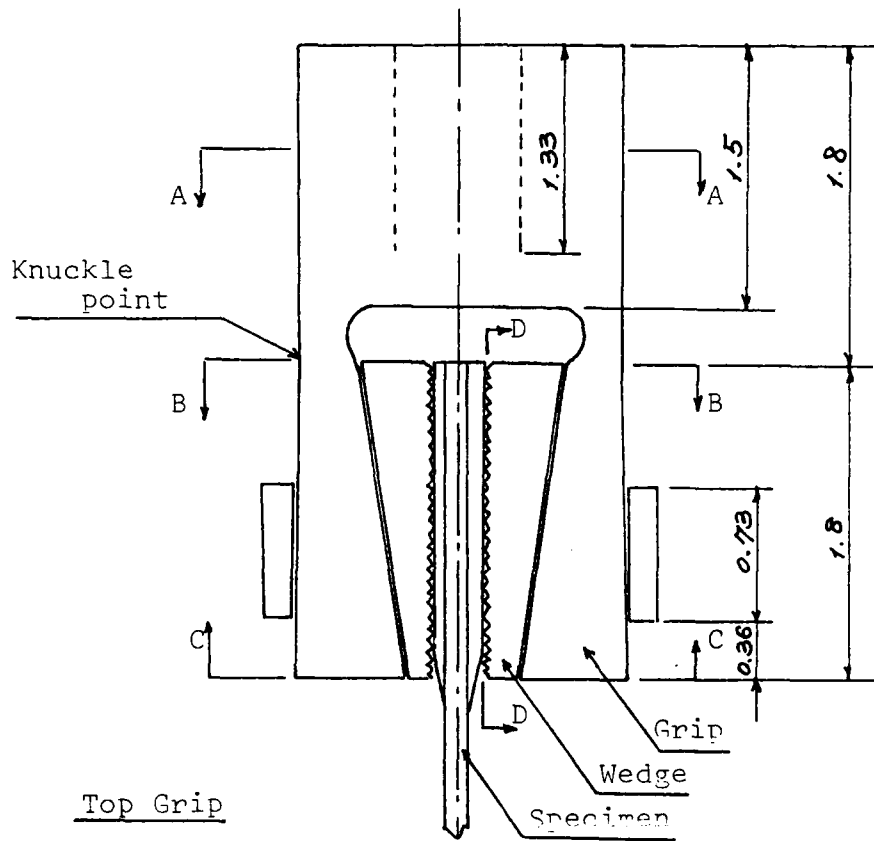
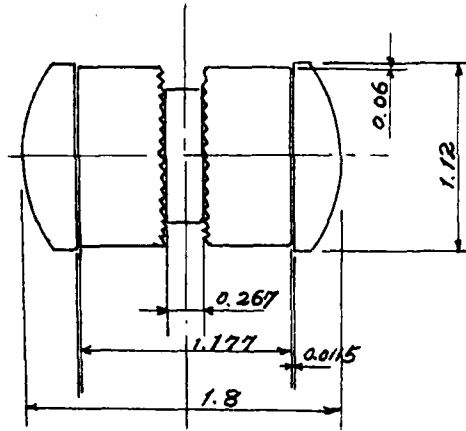
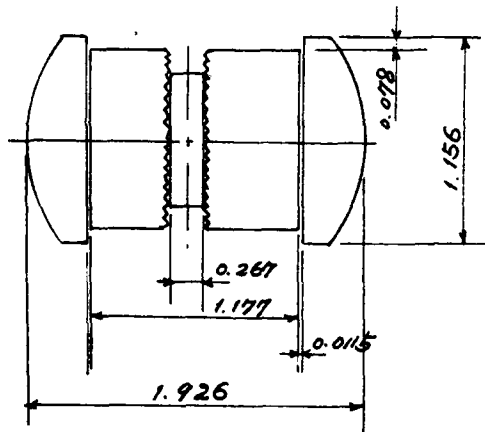

Figure D.2. New Design Wedge Coupling System:



Section B-B



Section C-C

Figure D.3. New Design Wedge Coupling System

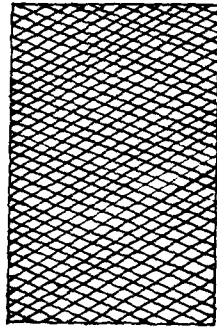

Section D-D  
(wedge Knurl)

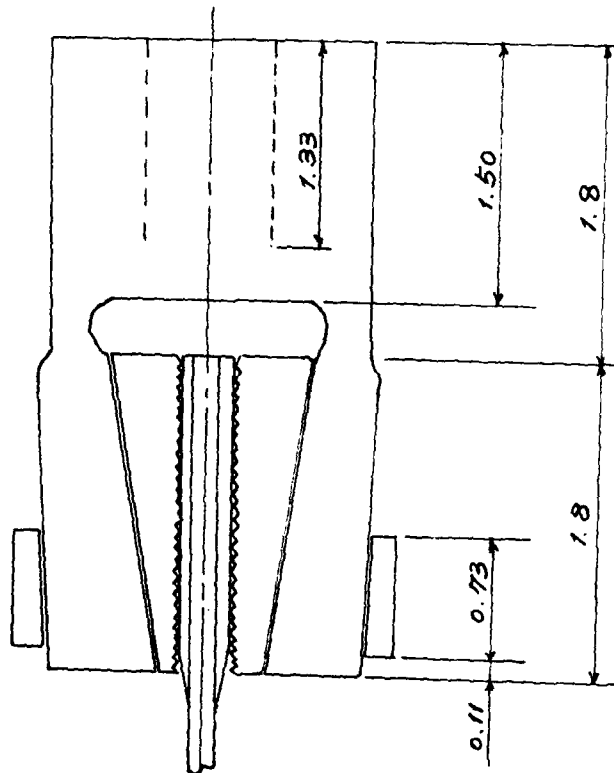

Bottom Grip

Figure L.4. New Design Wedge Coupling System

APPENDIX E

STRAIN RATE OF COMPOSITE MATERIAL  
AT ELEVATED TEMPERATURE

The ultimate tensile strength of composite materials depends on the strain rate, moisture content, and the matrix material (resin) content at a specified temperature. The strain rate for this investigation, ( $1.0 \times 10^{-4}$  in/in  $\times$  sec), was determined from previous similar experimental results as shown in Table IV.

TABLE IV  
Strain Rate of Composite Material  
at Elevated Temperature

Strain rate (in/in*sec)	Test temp- rature(*F)	Equipment	Material	Specimen dimension (L B D) inch	Cross head speed(in/min)	Refer- ence
$8 \times 10^{-4}$	75 ~ 250	hydraulic machine	epoxy graphite 8 layer cross ply sheet (+45/-45/-45/0/90) <sub>5</sub>	11. x 0.75 x 0.044 w/tab		8
$10^{-4}$	R.T	"	T300/5208 epoxy(epoxy graphite fiber with (0/90/+45/-45) <sub>5</sub> )	2.5 x 1.0 x 0.1023 w/tab		22
$8.3 \times 10^{-5}$ $8.3 \times 10^{-4}$ $8.3 \times 10^{-3}$	R.T " "	unknown	boron epoxy (0/90)	unknown		23
$3.0 \times 10^{-4}$	R.T, 260	MTS	graphite epoxy thonel300/namco 5208 (0/0/+45/-45) <sub>25</sub> , (90/90/+45/-45) <sub>25</sub> , (0/+45/-45/90) <sub>25</sub>	5.24 x 1.0 x 0.08	0.04	15
$1.5 \times 10^{-3}$	R.T	INSTRON TT-1115	graphite epoxy AS/3501-5 ((0/+45 <sub>9</sub> /90) <sub>5</sub> )	9.0 x 1.0 x 0.07 w/tab	0.2	24
$3.6 \times 10^{-4}$	-110 ~ 350	INSTRON 10,0001b	graphite epoxy thonel 300/fiberite 1034 0° layup, 45° layup	3.97 x 0.5 x 0.035 w/tab	0.05	6
$1.5 \times 10^{-4}$	R.T	INSTRON	HT-S/ERLA 2256 graphite/composite	unknown	0.02	25
$1.4 \times 10^{-4}$	R.T, 200	MTS	graphite epoxy AS/3501-6 ((+45/-45/0/0/0/90) <sub>5</sub> )	unknown		26
$1.5 \times 10^{-4}$	1004, 1400, 1760	INSTRON 10,000 1b	graphite epoxy AS/3501-6 and fiber T 300/1034 (0/+45/-45/90) <sub>5</sub> 16 ply 24 ply, 32ply	9.0 x 0.5 x 0.075 9.0 x 0.5 x 0.11 9.0 x 0.5 x 0.15	0.02	7

APPENDIX F  
EXPERIMENTAL DATA

TABLE V  
#1 Panel Experimental Data  
at Elevated Temperature

Specimen I.D	Temp. (°F)	Ultimate Tensile Strength		Elastic Modulus	
		Measured (KSI)	Difference (%)	Measured (MSI)	Difference (%)
SB-016-1	58	67.776	-2.5	7.378	6.4
SB-016-2	58	70.299	1.2	6.490	-6.4
SP-016-3	58	68.173	-1.9		
SB-016-4	58	71.669	3.2		
Average		69.475		6.934	
SB-050-1	122	60.133	-7.7		
SB-050-2	122	65.739	0.9		
SB-050-3	122	68.888	5.7	7.918	5.5
SB-050-4	122	65.887	1.1	7.086	-5.5
Average		65.162		7.502	
SB-080-1	176	66.634	0.9		
SB-080-2	176	65.983	0.1	5.317	-20.5
SB-080-3	176	65.726	-0.5		
SB-080-4	176	65.854	-0.3	8.057	20.5
Average		66.049		6.687	
SB-110-1	230	61.477	-3.3		
SB-110-2	230	62.204	-2.2	5.433	-0.2
SB-110-3	230	65.335	2.8	5.455	0.2
SB-110-4	230	65.294	2.7		
Average		63.578		5.444	
SB-140-1	284	63.937	0.7	5.238	6.6
SB-140-2	284	61.830	-2.7		
SB-140-3	284	61.728	-2.9	4.592	-6.6
SB-140-4	284	66.743	5.0		
Average		63.560		4.915	
SB-170-1	338	46.782	2.0		
SB-170-2	338	47.019	2.5	4.069	5.4
SB-170-3	338	44.363	-3.3	4.137	-5.4
SB-170-4	338	45.344	-1.2		
Average		45.877		4.373	

TABLE VI  
#2 Panel Experimental Data  
at Elevated Temperature

Specimen I.D	Temp ( F)	Ultimate Tensile Strength		Elastic Modulus	
		Measured (KSI)	Difference (%)	Measured (MSI)	Difference (%)
SB-016-1	58	60.018	-4.4		
SB-016-2	58	69.128	10.1		
SB-016-3	58	58.640	-6.6	6.915	-1.5
SB-016-4	58	63.323	0.9	7.125	1.5
Average		62.777		7.020	
SB-050-1	122	62.304	-6.5		
SB-050-2	122	62.661	-5.9	6.794	-1.5
SB-050-3	122	65.448	-1.7	6.996	1.5
SB-050-4	122	75.984	14.1		
Average		66.599		6.895	
SB-080-1	176	62.015	-9.7		
SB-080-2	176	71.694	4.4	5.244	-8.2
SB-080-3	176	68.524	-0.2		
SB-080-4	176	72.459	5.5	6.181	8.2
Average		68.673		5.713	
SB-110-1	230	65.967	-5.4		
SB-110-2	230	66.194	-5.1	5.863	-5.5
SB-110-3	230	74.081	6.3		
SB-110-4	230	72.640	4.2	6.550	5.5
Average		69.721		6.201	
SB-140-1	284	65.791	0.0		
SB-140-2	284	60.084	-8.8	5.106	5.5
SB-140-3	284	69.561	5.6	4.570	-5.5
SB-140-4	284	67.988			
Average		65.856		4.838	
SB-170-1	338	47.360	1.1		
SB-170-2	338	47.291	0.9	4.880	-0.4
SB-170-3	338	46.889	0.0	4.915	0.4
SB-170-4	338	45.933	2.0		
Average		46.868		4.898	

TABLE VII  
#3 Panel Experimental Data  
at Elevated Temperature

Specimen I.D	Temp. ( F)	Ultimate Tensile Strength		Elastic Modulus	
		Measured (KSI)	Difference (%)	Measured (MSI)	Difference (%)
SB-016-1	58	65.582	8.8	8.884	9.5
SB-016-2	58	54.119	-10.2		
SB-016-3	58	54.927	-8.9		
SB-016-4	58	66.421	10.0	7.341	-9.5
Average		60.262		8.113	
SB-050-1	122	65.083	-1.1	7.722	-4.6
SB-050-2	122	67.302	3.0	8.460	4.6
SB-050-3	122	65.733	0.1		
SB-050-4	122	64.606	-1.8		
Average		65.806		8.091	
SB-080-1	176	71.648	-1.5	7.076	-6.7
SB-080-2	176	74.287	2.2		
SB-080-3	176	71.355	-1.9	8.090	6.7
SB-080-4	176	73.566	1.2		
Average		72.714		7.582	
SB-110-1	230	76.527	2.1	5.147	0.4
SB-110-2	230	79.360	5.8	5.102	-0.4
SB-110-3	230	72.357	-3.5		
SB-110-4	230	71.671	-4.4		
Average		74.980		5.125	
SB-140-1	284	72.569	-2.6	4.930	-7.0
SB-140-2	284	73.213	-1.7	5.668	7.0
SB-140-3	284	76.221	2.3		
SB-140-4	284	75.904	1.9		
Average		74.477		5.299	
SB-170-1	338	49.006	-0.5	4.826	7.9
SB-170-2	338	50.028	1.6	4.118	-7.9
SB-170-3	338	46.273	6.0		
SB-170-4	338	51.666	4.9		
Average		49.243		4.472	

## APPENDIX G

SPECIMEN WEIGHT

TABLE VIII

## Specimen Weight

Panel	Specimen I.D	Mass (Kg)	
		Original	Before Test
# 1	SB-016-1	27.45	27.45
	SB-016-3	27.52	27.52
	SB-050-1	27.46	27.46
	SB-050-2	27.48	27.48
	SB-080-1	27.24	27.24
	SB-080-3	27.40	27.40
	SB-110-2	27.25	27.25
	SB-110-3	27.20	27.20
	SB-140-1	27.43	27.43
	SB-140-4	27.05	27.05
	SB-170-2	27.47	27.47
	SB-170-3	27.05	27.05
# 2	SB-016-1	27.46	27.46
	SB-016-2	27.45	27.45
	SB-050-1	27.60	27.60
	SB-050-2	27.54	27.54
	SB-080-3	27.25	27.25
	SB-080-4	27.35	27.35
	SB-110-2	27.35	27.35
	SB-110-3	27.40	27.40
	SB-140-1	27.40	27.40
	SB-140-4	27.30	27.30
	SB-170-1	27.38	27.38
	SB-170-4	27.45	27.45

TABLE IX  
Specimen Weight

Panel	Specimen I.D	Mass (kg)	
		Original	Before Test
# 3	SB-016-2	27.40	27.40
	SB-016-3	27.47	27.47
	SB-050-1	27.30	27.30
	SB-050-3	27.39	27.39
	SB-080-3	27.40	27.40
	SB-080-4	27.60	27.60
	SB-110-1	27.27	27.27
	SB-110-2	27.40	27.40
	SB-140-1	27.50	27.50
	SB-140-4	27.30	27.30
	SB-170-2	27.20	27.20
	SB-170-4	27.25	27.25

### LIST OF REFERENCES

1. Ashton, J.E., Halper, J.C., and Petit, P.H., Primer on Composite Materials: Analysis, Technomic Publishing Company, 1969.
2. Jones, Robert M., Mechanics of Composite Materials, pp. 10-13, Scripta Book Company, 1975.
3. Naval Postgraduate School, Progress Report for Period, December 1980-September 1981, Strength Analysis of Composite Plates in a Thermal Environment, by David Salinas, p. 1.
4. Dastin, S., Lubin, G., Munyak, J., and Slobodzinski, A., "Mechanical Properties and Test Techniques for Reinforced Plastic Laminates," Composite Materials Testing and Design, ASTM STP 460, American Society for Testing and Materials, pp. 13-66, 1969.
5. Whiney, J.M., and Kim, R.Y., "High Temperature Tensile Strength of Graphite-Epoxy Laminates Containing Circular Holes," Journal of Composite Materials, Vol. 10, pp. 319-324, October 1976.
6. Tsai, S.W., Effects of Moisture and Temperature on the Tensile Strength of Composite Materials, The University of Michigan Mechanical Engineering Department, May 1977.
7. Hadcock, R.N., and Whiteside, J.B., "Special Problems Associated with Boron-Epoxy Mechanical Test Specimens," Composite Materials: Testing and Design, ASTM STP 460, American Society for Testing and Materials, pp. 27-36, 1969.
8. Meyn, D.A., and Shahinian, P., Effect of Temperature and Strain Rate on the Tensile Properties of Aluminum-Boron, Epoxy-Boron, and Epoxy-Graphite Composites, Naval Research Laboratory, Washington, D.C., June 1973.
9. The University of Michigan, Mechanical Engineering Department, AFML-TR-78-86, Effects of Moisture and Temperature on the Elastic Moduli of Composite Materials, by Tsai, S.W., August 1978.
10. O'Neill, G.S., Asymmetric Reinforcement of a Quasi-Isotropic Graphite-Epoxy Plate Containing a Circular Hole, pp. 53-54, M.S. and Engineer's Thesis, Naval Postgraduate School, June 1982.

11. Oplinger, Donald W., Gandhi, Kanu R., and Parker, Burton S., "Studies of Tension Test Specimens for Composite Material Testing," Army Material and Mechanics Research Center, April 1982.
12. Kim, R.Y., and Whitney, J.M., "Effect of Temperature and Moisture on Pin Bearing Strength of Composite Laminates," Journal of Composite Materials Application, Vol. 10, pp. 149-154, October 1976.
13. Peterson, R.E., Stress Concentration Factor, pp. 83-84, John Wiley and Sons, Inc., 1974.
14. Heywood, B., Designing by Photoelasticity, Chapman and Hall, Ltd., First Edition, 1952.
15. Carlos, Roberto, Santos, Alves, Stress Concentration in Fibrous Composite Material, M.S. Thesis, Naval Postgraduate School, June 1975.
16. Kural, M.H., and Flaggs, D.L., "A Finite Element Analysis of Composite Tension Specimens," Composites Technology Review, Vol. 5, No. 1, pp. 11-17, Spring 1983.
17. Becker, John J., Superplasticity in Thermomechanically Processed High Magnesium Aluminum-Magnesium Alloys, pp. 28-29, M.S. Thesis, Naval Postgraduate School, March 1984.
18. Sandhu, R.S., Ultimate Strength Analysis of Symmetric Laminates. February 1974.
19. Garber, D.P., Morris, D.H., and Everett, R.A., "Elastic Properties and Fracture Behavior of Graphite/Polymide Composites at Extreme Temperature," Composites for Extreme Environments, ASTM STP 768, American Society for Testing and Materials, pp. 73-91, 1982.
20. Adsit, N.R., "Some Experiences in Elevated Temperature Testing of Graphite/Reinforced Composite Materials," pp. 829-838, Proceedings of the 24th Sample Conference, 1979.
21. Pering, Gregory A., Farrell, Patrick V., and Springer, George S., Degradation of Tensile and Shear Properties of Composites Exposed to Fire or High Temperature, The University of Michigan, Mechanical Engineering Department, 3 October 1979.
22. Garber, D.P., "Tensile Stress Strain Behavior of Graphite/Epoxy Laminates," NASA Contractor Report 3592, 1982.

23. Leno, E.M., Knight, M., and Schoene, C., "Preliminary Evaluation of Test Standards for Boron Epoxy Laminates," Composite Materials Testing and Design, ASTM STP 460, American Society for Testing Materials, pp. 122-139, 1969.
24. AFFDL-TR-79-3064, Analytical-Experimental Correlation of the Behavior of 0, 45, 90 Family of AS/3501-5 Graphite/Epoxy Composite Laminates Under Uniaxial Tensile Loading, by Sandhu, R.S., May 1979.
25. Mechanics and Materials Research Center, Texas A&M University College Station, AFML-TR-73-179, Studies on the Viscoelastic Behavior of Fiber-Reinforced Plastic, by Schapery, R.A., Beekwith, S.W., and Conrad, N., pp. 42-45, July 1973.
26. Alper, James M., Determination of The Effect of Strain Rate on the Mechanical Properties of Graphite/Epoxy Laminates, pp. 7-21, Aircraft and Crew Systems Directorate Naval Air Development Center Warminster, 1 May 1983.

## BIBLIOGRAPHY

- AFML-TR-76-102, Moisture Absorption and Desorption of Composite Materials, by Springer, George S., and Shen, Chi-Hung., June 1976.
- Dow, Norris F., Humphreys, E.A., and Rosen, B.W., "Guidelines for Composite Materials Research Related to General Aviation Aircraft," NASA Contractor Report 3720, September 1983.
- Fahmy, A.A., and Ragai-Ellozy, A.N., "Thermal Expansion of Laminated Fiber Composites in the Thickness Direction," Journal of Composite Materials, Vol. 8, January 1974.
- Griffis, C.A., Masumura, R.A., and Chang, C.A., "Thermal Response of Graphite Epoxy Composite Subjected to Rapid Heating," Journal of Composite Materials, Vol. 15, September 1981.
- Kim, R.Y., and Soni, S.R., "Experimental and Analytical Studies on the Onset of Delamination in Laminated Composites," Journal of Composite Materials, Vol. 18, June 1984.
- Park, W.J., "On Estimation of Sample Size for Testing Composite Materials," Journal of Composite Materials, Vol. 13, July 1979.
- Tsai, Stephen W., and Hahn, H. Thomas, Introduction to Composite Materials, Technomic Publishing Company, 1980.

INITIAL DISTRIBUTION LIST

	No. Copies
1. Defense Technical Information Center Cameron Station Alexandria, Virginia 22314	2
2. Library, Code 0142 Naval Postgraduate School Monterey, California 93943	2
3. Department Chairman, Code 69Mx Department of Mechanical Engineering Naval Postgraduate School Monterey, California 93943	1
4. Professor David Salinas, Code 69Zc Department of Mechanical Engineering Naval Postgraduate School Monterey, California 93943	5
5. Professor Milton H. Bank, Code 34Bt Department of Aeronautic Engineering Naval Postgraduate School Monterey, California 93943	2
6. Dr. J.A. Bailie Organization 81-12, Building 154 Lockheed Missiles and Space Company, Inc. P.O. Box 504 Sunnyvale, California 90486	5
7. Library Officer Korea Naval Academy Jin Hae, Korea	2
8. Library Officer Korea Airforce Academy Seoul, Korea 130-09	2
9. Office of the Defense Attache Embassy of the Republic of Korea 2320 Massachusetts Avenue, Northwest Washington, D.C. 20008	1
10. Library Officer Korea Military Academy Seoul, Korea 130-09	2

11. Library Officer  
Korea Seoul National University  
Seoul, Korea 130-10

2

DATE  
ILMED  
— 8