

AD-A156 117

ELECTRON IRRADIATION OF N TYPE CADMIUM TELLURIDE(U)
NAVAL POSTGRADUATE SCHOOL MONTEREY CA C P BRAUER MAR 85

1/1

UNCLASSIFIED

F/G 18/8

NL

END

FILED

DTIC

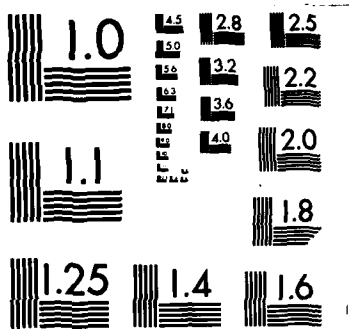

MICROCOPY RESOLUTION TEST CHART
NATIONAL BUREAU OF STANDARDS-1963-A

AD-A156 117

2/11/85 (3)

NAVAL POSTGRADUATE SCHOOL

Monterey, California



DTIC
ELECTE
JUL 03 1985
S D
G

THESIS

ELECTRON IRRADIATION OF n TYPE
CADMIUM TELLURIDE

by

Cletus P. Bauer Jr.

March 1985

Thesis Advisor:

K.C. Dimiduk

DTIC FILE COPY

Approved for public release; distribution is unlimited.

85 6 7 086

REPORT DOCUMENTATION PAGE		READ INSTRUCTIONS BEFORE COMPLETING FORM
1. REPORT NUMBER	2. GOVT ACCESSION NO.	3. RECIPIENT'S CATALOG NUMBER
4. TITLE (and Subtitle) Electronic Irradiation of n Type Cadmium Telluride		5. TYPE OF REPORT & PERIOD COVERED Master's Thesis; March 1985
7. AUTHOR(s) Cletus P. Bauer Jr.		6. PERFORMING ORG. REPORT NUMBER
9. PERFORMING ORGANIZATION NAME AND ADDRESS Naval Postgraduate School Monterey, California 93943		8. CONTRACT OR GRANT NUMBER(s)
11. CONTROLLING OFFICE NAME AND ADDRESS Naval Postgraduate School Monterey, California 93943		10. PROGRAM ELEMENT, PROJECT, TASK AREA & WORK UNIT NUMBERS
14. MONITORING AGENCY NAME & ADDRESS (if different from Controlling Office)		12. REPORT DATE March 1985
		13. NUMBER OF PAGES 74
		15. SECURITY CLASS. (of this report) Unclassified
		15a. DECLASSIFICATION/DOWNGRADING SCHEDULE
16. DISTRIBUTION STATEMENT (of this Report) Approved for public release; distribution is unlimited.		
17. DISTRIBUTION STATEMENT (of the abstract entered in Block 20, if different from Report)		
18. SUPPLEMENTARY NOTES		
19. KEY WORDS (Continue on reverse side if necessary and identify by block number) electron irradiation, radiation effects, cadmium telluride, CdTe		
20. ABSTRACT (Continue on reverse side if necessary and identify by block number) An experiment is described in which 30 MeV electrons were used to irradiate a sample of cadmium telluride. A brief history of irradiation studies of cadmium telluride is given, followed by the description of the construction of a laboratory used in the taking of Hall measurements and resistivity versus temperature data. The irradiation was performed at the Naval		

Postgraduate School linear accelerator facility and damage was observed in the CdTe sample at doses above 10^{13} electrons/cm². The sample was held at 100 K for the irradiation. Three results were noted from the Hall and resistivity data. First, the resistivity increased by a factor of two at radiation doses of 10^{15} electrons/cm². Secondly there was a ten percent lowering of the electron mobility at 77 K. Finally, possible annealing was seen at 160 K for the 10^{13} electrons/cm² dose resistivity versus temperature graph. Photoluminescence measurements confirmed the existence of damage by an increase of a broad maximum associated with defects.

Approved for public release; distribution is unlimited

Electron Irradiation of n Type Cadmium Telluride

by

Cletus P. Bauer Jr.
Lieutenant, United States Navy
B.S., Clarion State College, 1978

Submitted in partial fulfillment of the
requirements for the degree of

MASTER OF SCIENCE IN PHYSICS

from the

NAVAL POSTGRADUATE SCHOOL
March 1985

Accession For	
NTIS GRA&I	<input checked="" type="checkbox"/>
DTIC TAB	<input type="checkbox"/>
Unannounced	<input type="checkbox"/>
Justification	
By _____	
Distribution/	
Availability Codes	
Dist	Avail and/or Special
A/	

Author:

Cletus P. Bauer Jr.

Cletus P. Bauer Jr.

Approved by:

K. C. Dimiduk
K. C. Dimiduk, Thesis Advisor

D. L. Walters
D. L. Walters, Second Reader

G. E. Schacher
G. E. Schacher, Chairman, Department of Physics

J. N. Dyer
J. N. Dyer, Dean of Science and Engineering



ABSTRACT

An experiment is described in which 30 MeV electrons were used to irradiate a sample of cadmium telluride. A brief history of irradiation studies of cadmium telluride is given, followed by the description of the construction of a laboratory used in the taking of Hall measurements and resistivity versus temperature data. The irradiation was performed at the Naval Postgraduate School linear accelerator facility and damage was observed in the CdTe sample at doses above 10^{13} electrons/cm². The sample was held at 100 K for the irradiation. Three results were noted from the Hall and resistivity data. First, the resistivity increased by a factor of two at radiation doses of 10^{15} electrons/cm². Secondly there was a ten percent lowering of the electron mobility at 77 K. Finally, possible annealing was seen at 160 K for the 10^{13} electrons/cm² dose resistivity versus temperature graph. Photoluminescence measurements confirmed the existence of damage by an increase of a broad maximum associated with defects.

Additional keywords: radiation effects; Bulk Semiconductors; Photoconductivity; Infrared Semiconductors Detectors; computer programs.

TABLE OF CONTENTS

I.	INTRODUCTION -----	8
	A. OVERVIEW -----	8
	B. RADIATION -----	8
	1. Sources and Types of Radiation -----	9
	2. Semiconductor Irradiation Damage -----	10
	3. Importance of Radiation Studies -----	12
	C. CADMIUM TELLURIDE -----	13
	1. Properties -----	13
	a. Structure -----	13
	b. Electrical Properties -----	14
	2. Uses of CdTe -----	15
	D. HISTORY OF IRRADIATION STUDIES ON CDTE -----	15
II.	THEORY -----	21
	A. MEASURING BULK SEMICONDUCTOR PROPERTIES -----	21
	1. Hall Effect -----	21
	2. Van der Pauw Method -----	26
	B. HIGH ENERGY ELECTRONS IN MATTER -----	28
	C. PHOTOCONDUCTIVITY OF CDTE -----	33
	D. GENERATION, RECOMBINATION, AND LIFETIME -----	36
III.	THE EXPERIMENT -----	42
	A. EXPERIMENTAL APPARATUS -----	42
	1. Semi-automated Hall Measurement System --	42
	2. Hall Switchbox -----	43
	3. Four Point Hall Probe -----	44
	4. Constant Current Power Supply -----	44

5.	Hall Magnet -----	46
6.	The NPS LINAC -----	46
7.	Variable Temperature Dewar -----	48
8.	Cadmium Telluride on Sapphire -----	49
B.	PROCEDURE -----	50
1.	Sample Preparation -----	50
2.	Pre-Irradiation Measurements -----	51
3.	The Irradiation -----	52
IV.	DATA AND RESULTS -----	54
A.	ELECTRICAL DATA -----	54
B.	DISCUSSION OF ELECTRICAL DATA -----	57
1.	Resistivity Increasing With Temperature--	57
2.	Radiation Effect on Resistivity/Mobility-	59
3.	Annealing at 160 K -----	60
C.	PHOTOLUMINESCENCE DATA AND DISCUSSION -----	63
V.	CONCLUSIONS -----	66
	APPENDIX A: HALL MEASUREMENT COMPUTER PROGRAM -----	68
	LIST OF REFERENCES -----	72
	INITIAL DISTRIBUTION LIST -----	74

ACKNOWLEDGEMENT

I would like to thank Dr. Kathryn C. Dimiduk for her encouragement on this project over the past year.

Dr. Paul Newman, Dr. J. Bajaj, and the people at Rockwell International Science Center supplied the samples and their valuable time allowing this to become a more meaningful project.

A special gratification to Dr. Frank Junga and the people at Lockheed Missiles and Space Cooperation Research Center at Palo Alto, Ca. For six weeks I enjoyed learning about semiconductor measurements at their facility. Their instruction helped me to develop the technical skills necessary to complete this project.

I. INTRODUCTION

A. OVERVIEW

Infrared semiconductor detectors, using materials such as Mercury Cadmium Telluride (HgCdTe), are finding applications in military tracking, guidance, and surveillance systems. Because these are military systems, it is conceivable that they might be subjected to nuclear environments, primarily from nuclear weapons. Radiation studies are needed to determine the survivability and impairment levels of equipment exposed to ionizing radiation. Cadmium Telluride (CdTe) is used as a substrate material for HgCdTe IR detectors. It is believed that an understanding of radiation effects in CdTe and HgCdTe is necessary so that radiation hardened HgCdTe detectors can be manufactured. Radiation studies are conducted at facilities using particle accelerators, gamma ray sources, or neutron sources. The linear accelerator facility at the Naval Post Graduate School located at Monterey, California has the capability to do electron radiation damage studies in semiconductor materials and devices.

This thesis discusses the irradiation of a CdTe sample using high energy electrons. A description of the nuclear environment, the material, and a history of radiation studies are included in this chapter. A laboratory has been

set up at the school for measuring semiconductor parameters in bulk materials. This paper will discuss the development of the laboratory, measurements of semiconductor parameters (including some important measurements not yet implemented at the school), and show how high energy electrons interact with the material and why the bulk electrical parameters change. An experiment is described where radiation damage to a CdTe sample is observed by measuring the changes in several semiconductor parameters.

B. RADIATION

There are various radiation sources and radiation types that affect semiconductor devices and infrared detectors which use cadmium telluride. The sources and types of radiation, semiconductor damage mechanisms, and the importance of radiation studies are discussed below.

1. Sources and Types of Radiation

The three main radiation sources that might affect cadmium telluride semiconductors are nuclear weapons, nuclear reactors, and the Van Allen Radiation Belt. Radiation simulators such as the linear accelerator (LINAC) also produce radiation which can be used in experiments.

Nuclear weapon detonations produce several types of radiation. The energy of a burst is partitioned into several forms. Typical output partition for weapon energy is 50-80% into x-ray production, 10-20% into kinetic energy of the fission fragments and debris (includes ions and

electrons), 1% into neutron production, and 0.5 % into gamma ray production [Ref. 1]. Fig. 1. illustrates the types and partitioning of radiation. Electromagnetic pulse (EMP) is created by the gamma rays interacting with the atmosphere. High energy electrons are produced either directly by the weapon (fission fragments) or indirectly by way of gamma rays producing electrons.

A second source of radiation is the Van Allen Radiation Belt. It is a region of trapped charged particles in the earth's magnetosphere. These particles can be either protons or electrons with energies in the Mev range. The peak Van Allen flux is 10^8 electrons/cm². [Ref. 1]

Nuclear reactors emit neutrons, x-rays, and gamma rays. Reactor shielding limits any radiation outside the containment vessel; however, instrumentation using semiconductors within the reactor will be subjected to radiation. These instruments may be degraded by radiation damage.

2. Semiconductor Irradiation Damage

There are two principle damage mechanisms in semiconductor devices; displacement and ionization [Ref. 2]. Ionization damage is the result of stripping the orbital electrons from the atoms in a crystal to form ionized atoms and free electrons. Neutrons, prompt gamma rays, gamma rays and high energy electrons can cause ionization damage. This form of damage is usually temporary

NUCLEAR WEAPON ENERGY PARTITION

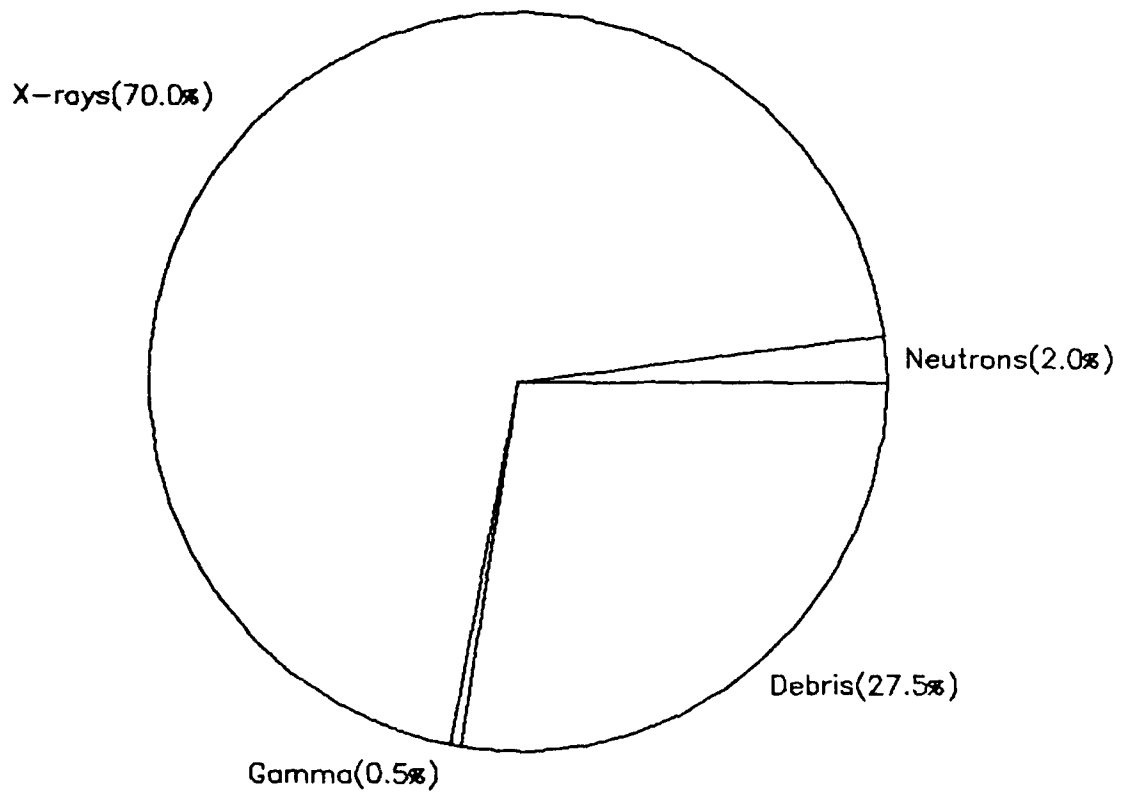

Figure 1. Nuclear Weapon Energy Partition.

majority electrons is:

$$\vec{F}_y = q (\vec{E}_y + \vec{v} \times \vec{B}_z) \quad (7)$$

The electric field, E_y , opposes electron flow to the right. The field will build up until there is no further current in the y direction. At this point, the force on the electron due to the magnetic field is equal to the force on the electron due to E_y . The net force, F_y is therefore zero. The Hall field can now be found:

$$E_y = -v B_z \quad (8)$$

Substituting Equations 3 and 4 into Equation 8 gives the mobility of the electron in terms of the measurable quantities E_x , E_y , and B_z .

$$\mu_n = \frac{-E_y}{E_x B_z} \quad (9)$$

Substituting Equations 1 and 5 into Equation 8 allows the carrier concentration n to be determined from measured parameters J_x , B_z , and E_y .

$$n = - \frac{J_x B_z}{q E_y} \quad (10)$$

Thus the velocity of the electron is proportional to the electric field in the x direction on the sample. The coefficient is called the mobility and is given the symbol μ_n .

$$\mu_n = \frac{q \tau}{m_n^*} \quad (4)$$

The conductivity, σ , (an important electrical parameter), is the product of the unit charge q , the carrier concentration n , and the mobility for electrons.

$$\sigma = q \mu_n n \quad (5)$$

The resistivity, defined as the reciprocal of the conductivity, is therefore:

$$\rho = (q \mu_n n)^{-1} \quad (6)$$

If a magnetic field is applied in the positive z direction, (B_z), there will be a force exerted on the electrons in the y direction (E_y). Electrons will be forced to the right, causing an electric field, E_y , in the positive y direction to be developed. This field is called the Hall electric field. Fig. 4 shows the direction of the components of the electric field. The Lorentz force for the

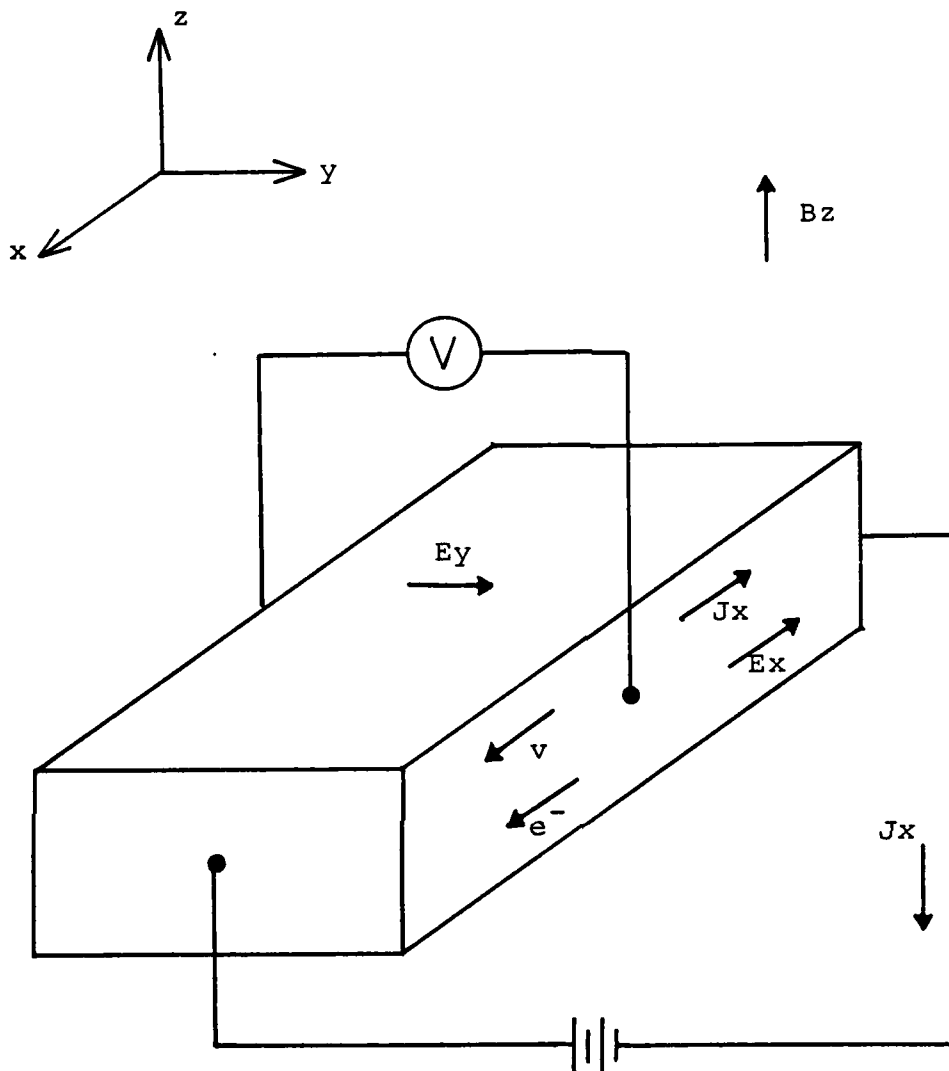

Figure 4. Hall Sample Geometry.

electrons are the majority carriers, and only electrons will be discussed here. If the sample was p type, a similar development could be made for holes .

A simple description of the Hall effect is presented below. Consider a block of n type semiconductor material which has electrons for majority carriers, as illustrated in Fig. 4. If a battery is connected across the x axis as shown, an electric field, E_x , will be developed across the sample and a current density, J_x , will flow. The current density and the electric field are related by Ohm's law, where σ is the conductivity.

$$J_x = \sigma E_x \quad (1)$$

Equating the impulse on the electron (Force x Time) to its momentum gives Equation 2.

$$-q E_x t = m_n^* v \quad (2)$$

m_n^* is the reduced mass, v is the electron drift velocity, q is the unit charge, and t is the time between collisions of the electrons. Solving for v gives:

$$v = \frac{q t E_x}{m_n^*} \quad (3)$$

II. THEORY

This chapter discusses the theory of semiconductor measurements used to characterize CdTe samples. Interaction of high energy electrons with matter and radiation damage in semiconductors will also be discussed. The study of the photoconductivity of cadmium telluride will give insight into how a CdTe photocell is degraded by radiation. Generation, recombination and lifetime are also discussed.

A. MEASURING BULK SEMICONDUCTOR ELECTRICAL PROPERTIES

The radiation measurements in this study were all done on bulk semiconductor materials. Some of the electrical semiconductor parameters to be studied are resistivity, majority carrier concentration, mobility, and lifetime. All of these properties can be changed with radiation damage. Hall measurements will determine all of the above parameters except lifetime. The following sections discuss the theory of the Hall effect and the Van der Pauw technique.

1. Hall Effect

One important tool available for determining bulk semiconductor properties is Hall effect measurements. Hall measurements yield majority carrier concentration, majority carrier mobility, majority carrier type and resistivity data. Since the sample studied in this paper is n type,

Nuclear environments, including high energy electrons, can cause displacement damage in a sample of CdTe. The effect of the displacement damage and defects has been studied extensively since the early 1960's. Because CdTe is an important compound with a variety of applications, especially in the development of IR detectors, radiation studies are still being completed. The next chapter will give the theory of the electrical properties to be measured in this radiation study.

Lorentz et al. 1963 Ref. 6,7 Electrons n type	Urli et al. 1968 Ref. 8 Neutrons n, p type	Bryant et al. 1968 Ref. 11 Electrons p type	Abromov et al. 1971 Ref. 13 e ⁻ , Neutrons n, p type	Caillot 1971 Ref. 14 Electrons n type	Taguchi et al. 1979 Ref. 15, 16 e ⁻ , γ, n n, p type
<u>Ec - .06</u>	<u>Ec - .02</u> <u>Ec - .6</u> <u>Ev + .36</u> <u>Ev + .2</u>	 <u>Ev + .46</u> <u>Ev + .036</u>	<u>Ec - .06</u> <u>Ev + .17</u>	 <u>Ec - .6</u> <u>Ev + .46</u>	<u>Ec - .056</u> <u>Ec - .5</u> <u>Ev + .014</u>

Ec

Ev

1.6 eV

Figure 3. Radiation Induced Energy Levels.

There is a comment at the end of the paper that reports that all observed damage anneals at 77 K and that room temperature irradiations do not produce stable defects which show edge emission.

Abramov et al. of the U.S.S.R. irradiated p and n type samples with 1 MeV electrons and neutrons (1971) [Ref. 13]. Hall and photoconductivity measurements showed damage defects at $E_c - 0.06$ eV and $E_v + 0.17$ eV.

M. Caillot of the University of Paris VII, France irradiated an n type sample with 1.5 MeV electrons [Ref. 14]. He observed a $E_c - 0.6$ eV defect involving cadmium vacancies which anneal at about 200 K. Another site at $E_v + .46$ which was believed to be caused by Te vacancies annealed at 77 K. This level was also seen by Bryant earlier [Ref. 11].

Two damage studies were conducted in Japan (1978, 1979) by Taguchi et al. to determine degradation of CdTe gamma and x-ray detectors [Ref. 15, 16]. Electrons, gamma radiation and neutrons were used. They reported a large decrease in mobilities for both holes and electrons because of an electron trap at $E_c - 0.5$ eV, and a hole trap at $E_v + 0.14$ eV.

Fig. 3 shows the positions of the damage traps within the forbidden band for the above references.

Barnes and Kikuchi also irradiated n type samples in 1967 with thermal neutrons at the University of Michigan Ford Reactor [Ref. 10]. Their results show that the removal of electrons, decreasing n carrier concentration, is due to the removal of the cadmium atom from its lattice site. This vacancy did not anneal at room temperature after removal from the radiation flux. Barnes and Kikuchi also state that p type sample defects anneal out at temperatures between 160 and 200 K.

Bryant and Webster from the University of Hull, England also studied CdTe in 1967 [Ref. 3]. n type samples were made by heating p Type CdTe crystals to 900 C under Cd overpressure. Both types of samples were irradiated with 100-400 KeV electrons from a Van de Graaff generator. For p type samples, he determined the energy threshold for electron damage to be 340 KeV. Annealing was observed for the p type sample at temperatures between 130 and 140 K.

Bryant co-authored two other papers on electron irradiation effects in CdTe. Luminescence studies on p type material irradiated at liquid helium temperatures showed a 235 KeV electron energy threshold for simple cadmium vacancies [Ref. 11]. 340 KeV electrons result in displacements of both cadmium and tellurium. In a later paper, cathodoluminescence edge emission of CdTe was studied before and after irradiation [Ref. 12]. Intensities of three band edges were seen for the cadmium displacement.

temperatures and is 0.06 eV below the conduction band minimum [Ref. 6]. The same defect was seen when a similar sample was irradiated with 1.5 MeV electrons at room temperature [Ref. 6 and 7]. They were also able to produce a p type sample by annealing an n type sample at high temperature. This causes cadmium atoms to vaporize leaving cadmium vacancies which are acceptors.

Four independent CdTe radiation studies were published in 1967. Urli irradiated p-type CdTe samples with thermal and fast neutrons at the Semiconductor Laboratory Institute at Zagreb, Yugoslavia [Ref. 8]. An increase in resistivity of four or five orders of magnitude was reported. One sample that was irradiated with slow neutrons changed from p to n type when cooled below 140 K. A negative photoconductivity was observed just below this temperature.

Gamma rays (Co^{60} and Cs^{137}) and thermal neutrons were used to irradiate n type samples in the same year by Chester [Ref. 9]. Cs photons (.662 MeV) were found to displace Te atoms, whereas Co photons (1.17 and 1.33 MeV) displaced Cd atoms. He reasoned that when charged particles such as high energy electrons bombard a binary semiconductor both types of atoms will be displaced. Since the tellurium atom has the larger electron cloud it would preferentially be displaced. This displaced Te atom causes acceptors in CdTe, (tellurium interstitials).

to the use of foreign atom dopants. For example, if a sample of CdTe is heated (annealed) using overpressures of cadmium, then cadmium interstitials (point defects) will result in an n type material. For CdTe, donors are either Te vacancies or Cd interstitials. Acceptors (for p type) are either Te interstitials or Cd vacancies. Dopants can also be added to the compound to make the sample a certain type. Au, Cu, and Ag will act as acceptors if substituted for Cd in the lattice [Ref. 5]. These same elements will act as donors if they fill interstitial sites.

2. Uses of CdTe

Cadmium Telluride is an important semiconductor that has a variety of uses. Some are: Gamma ray and x-ray detectors, nuclear medicine, nuclear weapons, optical modulators, laser components, interferometers, solar cells, liquid crystal displays, photoconductors, IR detectors, and substrates for other semiconductors. Ref. 5 gives detailed discussions of the applications of CdTe.

D. HISTORY OF IRRADIATION STUDIES ON CADMIUM TELLURIDE

A significant amount of radiation work has been done on CdTe since 1960 in the United States, Japan, England and the Soviet Union. The radiation studies all strive to understand the nature of point defects in the material. Lorenz, Segall, and Woodbury produced a unique double acceptor defect in CdTe by heat treating the sample to 800-1000 C in cadmium. This defect is a hole trap at low

Wurtzite structures can be found in thin films. The sphalerite structure is also FCC and the wurtzite structure is hexagonal close packed (HCP). Electrical, optical and thermal properties differ for different CdTe structures.

The phase diagram for cadmium telluride is shown in Fig. 2. [Ref. 5]. The maximum melting point is 1092 C at 50% concentration. The eutectic temperature for Cd is 324 C and the eutectic temperature for Te is 449 C.

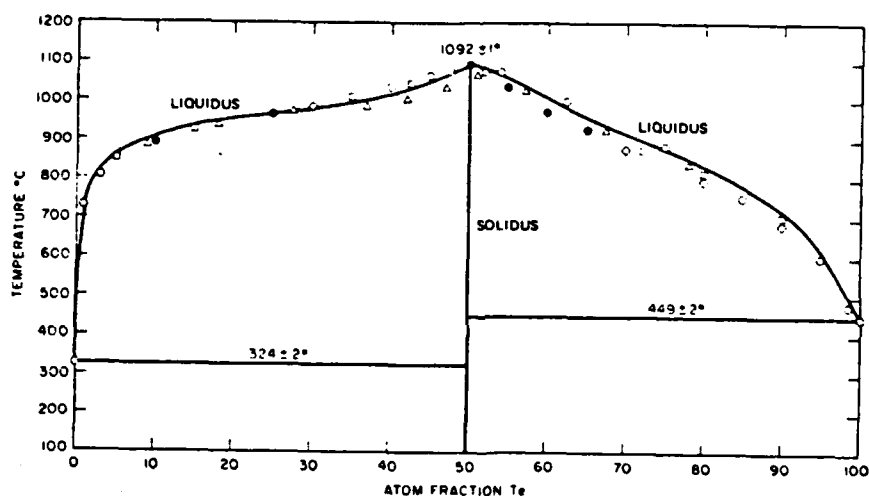

Fig. 2. CdTe Phase Diagram [Ref. 5].

b. Electrical properties

The electrical properties of a CdTe semiconductor are determined during the manufacturing process. A sample can be either p or n type. Unlike silicon, a II-VI compound's type can be changed by the adding or subtracting of one of the two elements in addition

environments. Bulk material or device electrical parameters can be measured before and after irradiation to determine the sensitivity to radiation. The studies determine the levels of shielding or electronic circumvention necessary to harden systems.

C. CADMIUM TELLURIDE

1. Properties

Cadmium Telluride (CdTe) is a II-VI semiconductor compound. Cadmium is a column II element that has two electrons in its outermost shell ($5s^2$) and Tellurium is a column VI element with six outermost electrons ($5s^2, 5p^4$). The binding of the compound is both ionic and covalent and the compound has properties of both types of bonds [Ref. 4]. The compound has semiconductor properties with a band gap of 1.6 eV.

a. Structure

The structure of CdTe can be of three types: Zinc Blende, Sphalerite, or Wurtzite [Ref. 5]. The stable form of cadmium telluride bulk crystals at atmospheric pressures is zinc blende. In this form, cadmium atoms and tellurium atoms are both face centered cubic lattices (FCC) with each tetrahedral site of one type filled with an atom of the other type. Each atom is surrounded tetrahedrally with four atoms of the other element. The lattice parameter (the length of the side of one edge of an FCC unit cell) is 6.481 Angstroms [Ref. 5]. Both the sphalerite and the

in nature in metals and semiconductors because surges in carrier density cause transient effects in the electrical properties of the device. In insulators, this type of damage can have permanent effects.

Displacement damage (sometimes called bulk radiation damage) refers to the physical damage to a crystal lattice produced by knocking an atom from its lattice position to another location in the lattice. Although neutrons are usually the primary cause of displacement damage, high energy electrons and gamma rays can also cause defects in the lattice. If a high energy electron with an energy above a certain damage threshold collides with an atom in a semiconductor lattice, a point defect called a vacancy will result. That atom is now repositioned, producing an interstitial atom. The energy damage threshold for cadmium telluride (CdTe) was determined in 1967 to be 340 keV by F. J. Bryant and E. Webster [Ref. 3]. These defect sites will result in changes to the electrical properties of the material. In this experiment it was hoped that some damage would be seen when a sample of CdTe was irradiated with 30 MeV electrons at the N.F.S. LINAC.

3. Importance of Radiation Studies

Radiation studies are useful in building an understanding of radiation damage mechanisms, developing hardened materials and devices, and for predicting survivability of electronic systems subjected to radiation

2. Van der Pauw Method

L. J. van der Pauw determined a method of measuring resistivity and Hall parameters which allowed measurements to be done on samples of arbitrary shape. [Ref. 17]. There are four restrictions on the sample. The ohmic contacts must be on the circumference. The contacts should have a small area. The sample should be homogeneous in thickness. The surface must be singly connected (no holes). The method of taking van der Pauw measurements is given here. Ref. 17 gives a formal proof of the mathematics behind this technique. Initially four contacts are made to the sample following the above restrictions. A sample of random shape with four contacts labeled a, b, c, and d around its circumference is shown in Fig. 5.

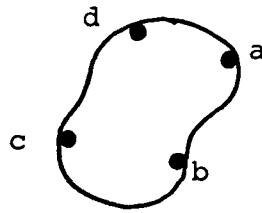

Figure 5. Van der Pauw Sample.

A current is run through contacts a and b. This current is called I_{ab} . A voltmeter measures a potential across contacts d and c which is called V_{dc} . The resistance is found using Ohm's law; $R_{ab,cd} = V_{dc} / I_{ab}$. This process is repeated after reversing the current and the two values of

resistance are averaged. Next the current is switched to flow through contacts b and c (I_{bc}) and the voltage is measured across contacts a and d (V_{ad}). Again the resistance is determined; $R_{bc,da} = V_{ad} / I_{bc}$. The current is again reversed and a second average resistance is found as before. The ratios of the two averaged numbers determine what is called the "f number", which is used in determining the specific resistance of the sample. This number is determined by a transcendental equation found in Ref. 17. The "f" number also gives the experimenter a good idea of the quality of the ohmic contacts. A high f number (greater than 2) on a geometrically square sample is an indication of a problem with the contacts or the associated equipment wiring. If the thickness "d" of a sample is known, then the resistivity of the sample can be found from the following equation:

$$\rho = \frac{\pi d}{\ln 2} \frac{(\bar{R}_{ab,cd} + \bar{R}_{bc,da}) f}{2} \quad (\Omega \text{ cm}) \quad (11)$$

In the second part of the van de Pauw experiment the Hall mobility and majority carrier concentration are determined. The sample is placed into a uniform magnetic field. A constant current power supply gives a current I_{ac} . The voltage is measured across contacts b and d (V_{bd}). The magnetic field is reversed and V_{bd} is again determined. The difference between these two values of V_{bd} is the Hall

voltage. The polarity of the power supply is now reversed and the process is repeated. The Hall voltages are again averaged and then divided by the current to give the quantity ΔR average ($\overline{\Delta R}$). Equation (12) is used to determine the Hall resistivity. This value is substituted into equation (13) to determine the mobility of the sample. The carrier concentration can then be determined by equation (14).

$$R_H = \frac{10^5 d \text{ (cm)} \overline{\Delta R} \text{ (\Omega)}}{2 B \text{ (K gauss)}} \quad (\text{cm}^3 \text{ c}^{-1}) \quad (12)$$

$$\mu_H = \frac{R_H}{\rho} \quad (\text{cm}^2 \text{ V}^{-1} \text{ s}^{-1}) \quad (13)$$

$$n = \frac{6.25 \times 10^{18}}{\mu_H \rho} \quad (\text{cm}^{-3}) \quad (14)$$

B. HIGH ENERGY ELECTRONS IN MATTER

This section shows how high energy electrons interact with CdTe. Rudie [Ref. 1] gives a comprehensive discussion of the interaction of beta particles (electrons) with matter. A high energy electron (30 MeV in this case) entering a material such as cadmium telluride will lose energy due to interaction of the charged particle with the

electric and nuclear fields of the target. The collisions with electrons result in excitation and ionization of the target atoms. The deflection of an electron due to nuclear fields result in an acceleration of the beta particle. If a charged particle is accelerated, it radiates electromagnetic radiation, a process called bremsstrahlung. The radiation is in the form of gamma rays. Therefore there are two main mechanisms for energy loss; collision losses due to interactions with electric fields of the atom and losses due to radiation. Both of these mechanisms can cause permanent damage in a sample of CdTe. The two interactions each have different stopping powers as discussed below.

Stopping power is defined as the energy loss per mass thickness of the target. It is a function of both the electron density or atomic number of the target and the incident energy of the beta particle. Rudie tabulates the stopping power in [Ref. 18]. There are three values for stopping power listed for each energy; one for collision, one for radiation, and one for the total. The three stopping power values for tin (Z=50), which is close to the atomic number for CdTe, for 30 MeV electrons are given below:

$$\frac{dE}{\rho dx}_{\text{coll}} = 1.45, \quad \frac{dE}{\rho dx}_{\text{rad}} = 2.83, \quad \frac{dE}{\rho dx}_{\text{Total}} = 4.28 \quad \left(\frac{\text{Mev cm}^2}{\text{g}} \right) \quad (15)$$

A critical energy exists above which the radiation effects dominate the collision effects [Ref. 1]. That energy can be approximated by the simple formula below:

$$E_c \approx \frac{800}{1.2+Z} \quad (16)$$

For a $Z=50$ the critical energy is found to be 16 MeV. Therefore if energies above 16 MeV are used, the value of $dE/\rho dX$ should be taken from the radiation tables instead of the collision tables. Since the LINAC energy is 30 MeV, the radiation value of stopping power will be used in dose calculations.

The range, r , is defined as the product of the material density and the distance the electron will travel before losing all of its energy. Ranges for several materials are also tabulated in Rudie [Ref. 18]. The range for a tin target with 30 MeV electrons is 12.45 g/cm². If this number is divided by the density of CdTe, the distance a single electron will travel in a thick sample of CdTe can be found. The density is 5.86 g/cm³ and therefore the distance is 2.1 cm.

The amount of energy lost into a thin sample can be determined as follows. The radiation stopping power is 2.83 MeV-cm²/g for Sn ($Z=50$). Multiplying the stopping power by

the density gives the amount of energy lost into the sample per centimeter as shown below:

$$\frac{dE}{\rho dx} \cdot \rho = \frac{dE}{dx} \quad (\text{MeV cm}^{-1}) \quad (17)$$

The amount of energy lost in a sample with a thickness of 20 microns is therefore determined to be .003 MeV. This is small compared to 30 MeV, therefore, the stopping power is essentially constant for the thin sample.

The dose will next be determined for a 20 micron thin sample of CdTe. Consider a fluence of n electrons incident on a sample of CdTe of area A and thickness d as illustrated in Fig. 6.

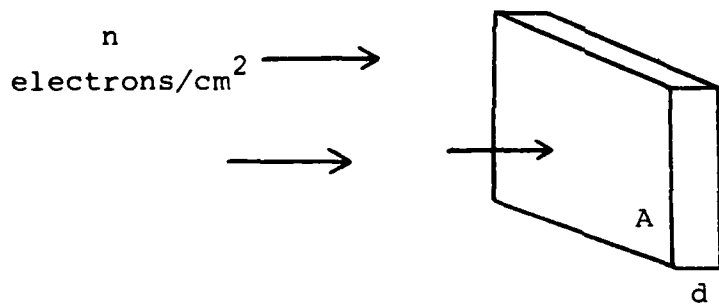

Fig. 6. CdTe Sample in Electron Beam.

Let the stopping power be equal to a constant k .

$$\frac{dE}{\rho dx} = k \quad (18)$$

Integrating Eq. 18 gives the energy gained by the sample from a single electron through the thickness d gives

$$E = k \rho d \quad (\text{MeV}) \quad (19)$$

since k is taken to be constant as justified above. Multiplying both sides of the equation by the number of electrons n , gives the total energy absorbed into the sample.

$$E_t = n k \rho d \quad (\text{MeV}) \quad (20)$$

Dividing both sides of the equation by the volume gives the total energy absorbed into a volume of area A and thickness d . This can be written in terms of Φ , the electron fluence in electrons/cm².

$$\frac{E_t}{V} = \frac{n}{A} k \rho \frac{d}{d} = \Phi k \rho \quad (21)$$

The energy per gram can be determined by dividing Eq. (21) by the density. A rad is defined to be 100 ergs of energy deposited into a gram of a particular material. The rad is material dependent and therefore the material must be

specified when giving doses in rads. Converting Mev to 100 ergs gives the desired result.

$$\text{Dose (rads)} = 1.6 \times 10^{-8} \phi k = 1.6 \times 10^{-8} \frac{dE}{\rho dx} \phi \quad (22)$$

The doses for CdTe are calculated for electron fluences of 10^{13} , 10^{14} , and 10^{15} electrons/cm² for both silicon and CdTe in Table 1. The radiation and collision doses are both computed. Aluminum and tin stopping power values are used for silicon and CdTe respectively. It is emphasized that the dose calculations given in Table 1 are approximate due to the uncertainty in the dose buildup factor. The fluence of electrons is the fundamental quantity used in this experiment.

C. PHOTOCONDUCTIVITY OF CADMIUM TELLURIDE

Studying the photoconductive properties of CdTe can help lead to an understanding of how the semiconductor is affected by radiation induced damage. Let photons illuminate the surface of a thin film CdTe sample as shown in Fig. 7.

TABLE 1
DOSE OF CDTE AND SILICON

Fluence ϕ e^-/cm^2	Dose in CdTe (rads CdTe)			Dose in Silicon (rads Si)		
	Collision $\frac{dE}{\rho dx} = 1.45$	Radiation $\frac{dE}{\rho dx} = 2.83$	Total $\frac{dE}{\rho dx} = 4.28$	Collision $\frac{dE}{\rho dx} = 1.75$	Radiation $\frac{dE}{\rho dx} = .997$	Total $\frac{dE}{\rho dx} = 2.75$
1×10^{13}	2.3×10^5	4.5×10^5	6.9×10^5	2.8×10^5	1.6×10^5	4.4×10^5
1×10^{14}	2.3×10^6	4.5×10^6	6.9×10^6	2.8×10^6	1.6×10^6	4.4×10^6
1×10^{15}	2.3×10^7	4.5×10^7	6.9×10^7	2.8×10^7	1.6×10^7	4.4×10^7

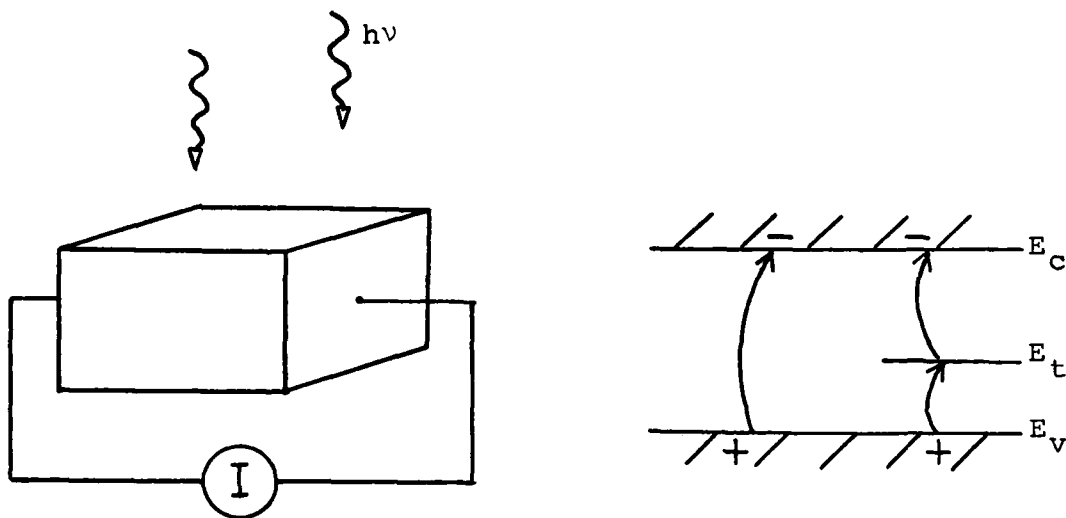

Fig. 7. Photoconduction in CdTe.

Carriers can be generated either by band to band transitions (intrinsic), or by carriers generated from energy states within the band gap (extrinsic). If the energy of the incident photon is greater than $E_g = E_v - E_c$, (the energy of the band gap), then an electron hole pair will be produced (intrinsic transition) which will cause an increase in the conductivity. The energy levels (E_t) in the forbidden gap can be caused either by doping or by defects such as those caused by radiation.

For a sample of intrinsic CdTe the conductivity is given by:

$$\sigma = q (\mu_n n + \mu_p p) \quad (23)$$

If the energy of the photon is greater than the energy gap, an electron hole pair will be produced and the conductivity will increase.

The cutoff wavelength for photo conduction is given by the Planck energy relation as shown in equation (24).

Using $E_g = 1.6$ eV for CdTe, we have:

$$\lambda_c = \frac{hc}{E_g} = \frac{1.24}{E_g(\text{eV})} = .775 \mu\text{m} \quad (24)$$

Notice that .775 microns is in the near infrared. Photoconductors manufactured using mercury cadmium telluride, which use cadmium telluride as a substrate, are used as infrared detectors. When photons with wavelengths shorter than the longwave cutoff enter the material, electrons are excited from the valance band into the conduction band and cause a photocurrent. To understand why photoconductors and photodiodes are degraded by radiation, it is necessary to study recombination, generation, and lifetime.

D. GENERATION, RECOMBINATION, and LIFETIME

Trapping and recombination centers are energy levels within the forbidden band of a semiconductor. There are four processes involving these energy levels that lead to an equation for the recombination rate of excess carriers. These processes are illustrated in Fig 8. Electron capture

is the process where an electron from the conduction band falls into a trap site. Electron emission is when an electron in the forbidden band energy site is elevated to the conduction band and becomes a carrier. The two processes involving the valance band are hole capture and hole emission. Hole capture is a hole in the valance band being annihilated by an electron falling from a trap site. Hole emission is the opposite process where an electron is excited from the valance band to the recombination center and leaves a hole behind.

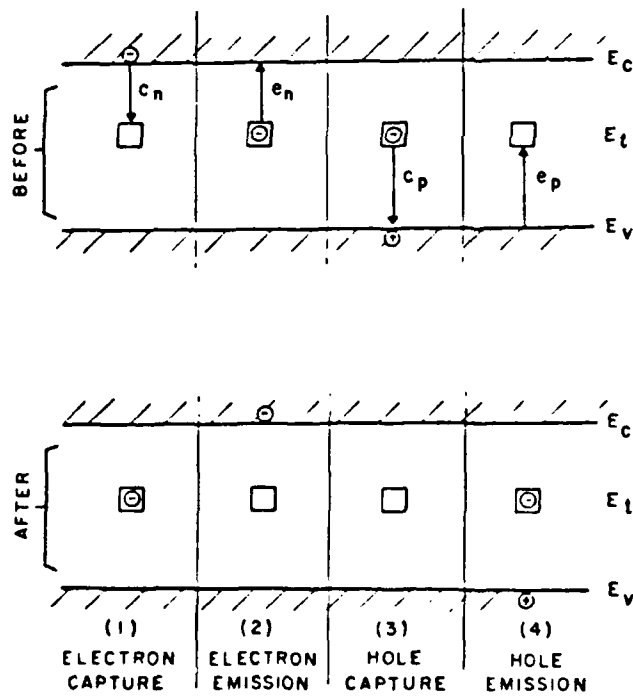

Fig. 8 [Ref.19]. Generation and Recombination.

The recombination rate shown in equation (25) is derived by analyzing the probabilities of the above events. [Ref.20]

$$U = \frac{\sigma_p \sigma_n v_{th} (pn - n_i^2) Nt}{\sigma_n [n + n_i \exp\left(\frac{E_t - E_i}{K T}\right)] + \sigma_p [p + n_i \exp\left(\frac{E_i - E_t}{K T}\right)]} \quad (25)$$

σ_n and σ_p are the hole and electron capture cross sections. v_{th} is the carrier thermal velocity, Nt is the recombination center density, E_t is the recombination energy level, and E_i is the intrinsic Fermi level. Two observations can be made about equation (25). At thermal equilibrium, the number of electron carriers times the number of hole carriers is always equal to the intrinsic carrier density squared:

$$np = n_i^2 \quad (26)$$

Then the recombination rate U is zero. Secondly, if the cross sections for electrons and holes are equal, then equation (25) can be simplified.

$$U = \sigma v_{th} Nt \frac{pn - n_i^2}{n + p + 2n_i \cosh\left(\frac{E_t - E_i}{K T}\right)} \quad (27)$$

In the above equation, we see that the more effective recombination centers are located near the middle of the

band gap. This is because as E_t approaches E_i , the cosh function approaches 1, its minimum value. If E_t is near a band edge the centers act primarily as electron or hole traps.

It is therefore noted that energy levels in the forbidden gap can have two effects. If the levels are midgap, they can act as "stepping stones" to aid in the generation and recombination of electron-hole pairs. If the levels are near the conduction band edge in n type material, they can trap electrons from the conduction band. The majority or minority carriers in n or p type material respectively, are then decreased, which is usually not desirable. If E_t is near E_v , the valance band in n type material, these sites (at E_t) in the forbidden band will act as hole traps to the minority carriers. The more important semiconductor parameter that is affected by trapping sites is carrier lifetime, the next topic of discussion.

"Carrier lifetime is the most important semiconductor parameter to be affected by lattice defects" [Ref. 21]. Rudie's statement emphasizes the importance of lifetime in semiconductor nuclear weapons effects. Carrier lifetime is the length of time in which a carrier lives after generation until recombination. Majority lifetime refers to the majority carrier and minority lifetime is the lifetime of the minority carrier. The minority carrier lifetimes for holes and electrons are:

fluences are approximately one third low because of the beam scattering which occurs in the aluminum cold finger before the beam is measured on the SEM. The fluence is probably 1.3×10^{12} , etc. Due to this uncertainty it is felt that the fluences are accurate to a factor of 2.

After each irradiation, the temperature of the sample was increased and resistivity data was again taken. Nitrogen was added and the samples were cooled before each subsequent run. Following the final irradiation, the sample was placed onto the four point probe and post irradiation Hall measurements were completed. The sample was held at room temperature for about one hour before Hall measurements were taken. The data will be given and discussed in Chapter 4.

The target chamber was pumped down to 5×10^{-6} torr and liquid nitrogen was added to the dewar. The temperature was lowered to 120 K. Pre-irradiation resistivity vs. temperature data was then collected with the following observations. With nitrogen in the dewar, the heater would only warm the sample by 20 degrees. To further warm the sample it was necessary to blow hot air from an air gun into the dewar to remove the nitrogen. By adjusting the power supply current, the temperature was able to be regulated to within one degree while a resistivity measurement was taken. The temperature was raised by 100 degrees in about two hours and data collection was terminated.

3. The Irradiation

The linear accelerator electron beam was focused and adjusted to 1 cm^2 on a focusing screen before the sample was rotated into the beam. The beam did show some fluctuations in intensity, however, the fluctuations varied in position with time. On the average it is believed that the whole sample received an even distribution of electrons. Video cameras monitored the sample and the thermocouple millivoltmeter while the irradiation was in process. The phosphor along the edge of the mount glowed, verifying that the sample was in the beam. During the irradiation the sample temperature never increased above 134 K.

Irradiations were completed at 10^{12} , 10^{13} , 10^{14} , and 10^{15} electrons/cm². An earlier experiment showed that these

sapphire substrate material was also supplied by Rockwell. A phosphor-lacquer solution was then carefully painted around the perimeter of the sapphire mount to monitor whether the sample was in the electron beam. (The excited phosphor glowed and left no doubt that the sample was in the beam.) The prepared sample was then soldered to the four point Hall probe for pre-irradiation Hall measurements. A Tektronix 576 curve tracer showed the contacts to be nearly ohmic with a slight "s" shaped current voltage curve.

2. Pre-Irradiation Measurements

Hall measurements were performed at room temperature and at liquid nitrogen temperature (77 K). The sample's resistivity changed from 2.22 ohm-cm at 77 K to 13.4 ohm-cm at 300 K. Unlike an intrinsic semiconductor, the resistivity increased with increasing temperature. The reason for this behavior is explained in the last chapter. The sample was then transferred to the cold finger on the "variable temperature" dewar used in the LINAC target chamber. A small amount of silicon heat sink compound was used to stick the sample to the aluminum block. A chromel-alumel thermocouple was attached to the sample to measure the temperature. Four wires from the contacts on the sample, two heater wires and the two thermocouple wires were passed through a high vacuum feed thru connector. The wires were then connected to the ammeter and voltmeters for measuring the resistivity and temperature.

and the other with a CdTe substrate, showed no noticeable change in resistivity after irradiation with 10^{14} electrons/cm². The CdTe sample (#7-154) did have a significant resistivity increase with the same electron fluence. Although the results of irradiation of this sapphire substrate material were not conclusive, it was decided that more studies would be done on CdTe. Two additional samples of #7-154 were supplied. Data on these samples are reported in Chapter 4.

B. PROCEDURE

This section will investigate how samples were prepared, explain how measurements were taken, and indicate how the radiation work was done.

1. Sample Preparation

N type cadmium telluride samples on a substrate of sapphire (Rockwell # 7-154) were prepared for Hall measurements as follows. The samples were square in shape, about 6 mm on a side. The samples were etched in a 1% bromine-methanol solution for 10 seconds to remove any oxide. Four small dots of 0.5% gold chloride solution were placed on each side edge of the sample. Indium was then melted to the spot with a fine point soldering iron. Next, thin silver wires were tinned with indium and then carefully soldered to the contact. Finally, the CdTe sample was attached to a 1 cm² piece of sapphire material with about one half of a drop of General Electric varnish No.7031. The

scattering of the electron beam before being measured by the SEM that was located behind the beam. A heater was wound with resistive magnet wire over a brass core which was fastened to the bottom of the cold finger. To insulate the heater wire from the brass, cigarette paper was soaked in General Electric varnish No.7031 and placed between the wire and core. The heating rate was controlled by varying the voltage applied to the heater coil. Because of the large heat capacity of the cold finger and its brass plate, the temperature increased at a very slow rate when the heater was energized. Although somewhat crude, the dewar was able to change temperature from about 100 K to room temperature within about two hours.

8. Cadmium Telluride on Sapphire

Samples of cadmium telluride and mercury cadmium telluride were supplied by Rockwell International. Rockwell had been improving mercury cadmium telluride infrared detectors by using sapphire substrates instead of cadmium telluride substrates [Ref. 22]. Rockwell's new fabrication technique was called FACE (producible alternative to cadmium telluride for epitaxy.) Since sapphire is an insulator, it seemed feasible that IR detectors manufactured using the FACE process might be more resistant to radiation than CdTe substrate IR detectors.

Three samples were irradiated at 94 K. The two mercury cadmium telluride samples, one with a FACE substrate

7. Dewar

The objective of this thesis was to measure resistivity of a sample of cadmium telluride as a function of temperature before and after irradiation at different radiation levels. To do this necessitated the construction of a dewar. The dewar had to perform two functions: first the sample had to be mechanically attached to a cold finger to keep the sample as cold as possible during the irradiation. This is because radiation damage would anneal out, or heal itself at elevated temperatures. Liquid nitrogen was used as a cryogen. Secondly, the temperature had to be increased slowly after irradiation to allow changes in resistivity verses temperature to be measured. A mechanical problem also existed. The dewar must be able to be rotated so that the electron beam could be focused on a target before the sample was placed in the beam.

A stainless steel insulated jacket from previous work was cleaned and reconditioned for the experiment. The dewar was semi-insulated from the atmosphere with an insulated bellows. It was rotatable, however, not without difficulty under high vacuum. There was a large brass flange approximately .5 inch thick which was used to hold a 2 inch by 2 inch aluminum cold finger. Aluminum, rather than copper, was used to prevent activation because it was not desirable to have a radioactive sample holder. The cold finger was limited in thickness to prevent excessive

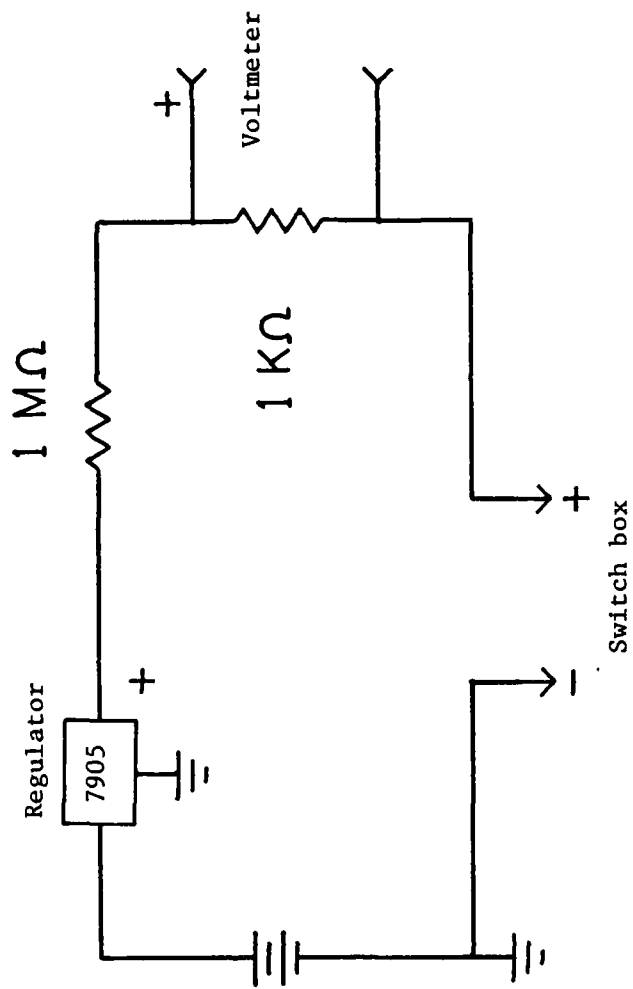

Figure 10. Constant Current Power Supply.

of a milliammeter to prevent the possibility of ground loops which could cause noise to be induced into the circuit. Fig. 10 is a schematic of the power supply.

5. Hall Magnet

A Varian V-3400 series 9-inch magnet was used to produce the constant magnetic field necessary for the Hall measurements. This magnet easily supplies the required 2-4 kilogauss field. A wooden structure was built to support a two inch diameter dewar which is positioned between the pole pieces for measurements at liquid nitrogen temperatures.

6. The NPS LINAC

The linear accelerator at the Naval Postgraduate School uses a series of three klystrons to accelerate electrons up to 100 MeV. This experiment utilized only one klystron to develop 30 MeV electrons. The LINAC operates at 60 pulses per second with a pulse duration in the microsecond range. A series of control magnets form and focus the electron beam. Electrons are focused on a target within an end station target chamber that is held at high vacuum (about one microtorr) with a diffusion pump. The electron fluence within the target chamber is measured using a secondary emission monitor (SEM). As the electrons impact the SEM, secondary electrons charge a capacitor. A voltage integrator measures a voltage developed across the capacitor which is proportional to the charge. This charge is proportional to the electron beam fluence.

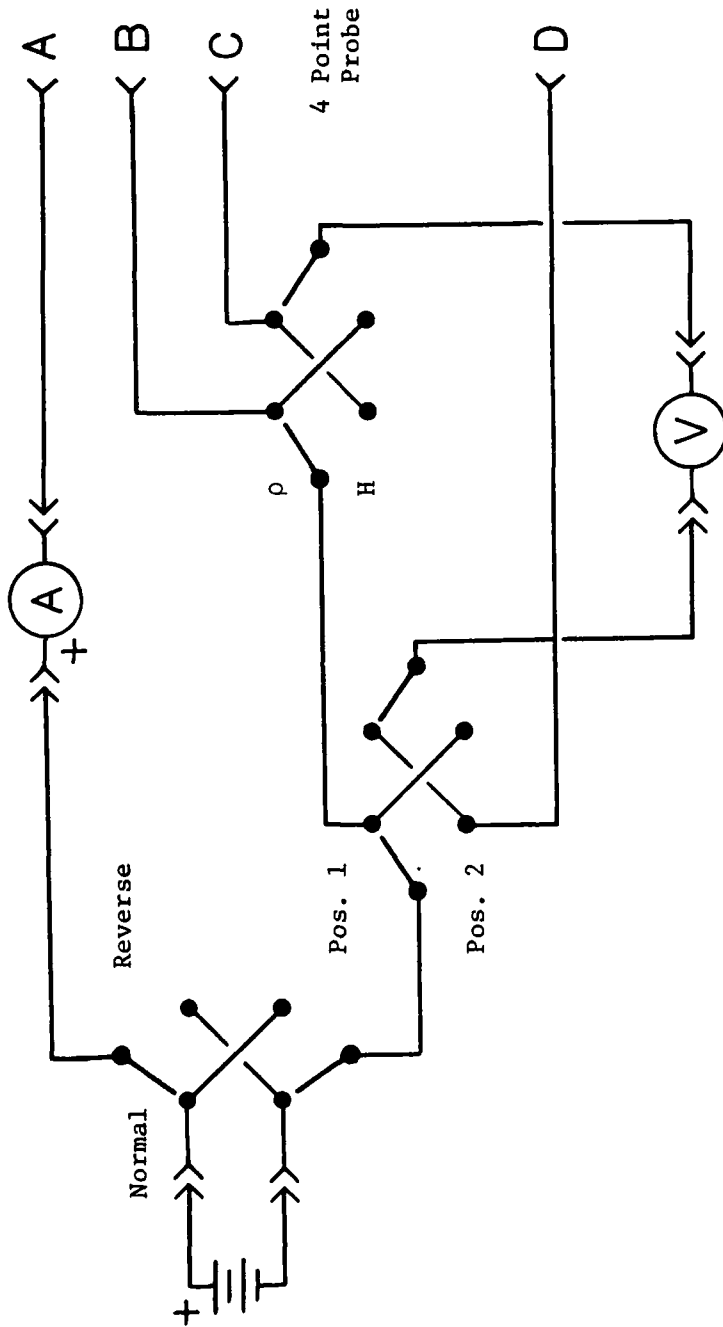

Figure 9. Hall Switch Box.

sample (a, b, c, d contacts). A schematic diagram is presented in Fig. 9.

3. Four Point Hall Probe

A four point Hall probe was constructed using a clever design observed at Rockwell International Science Center. The probe consisted of an approximately 30 cm section of circuit board material with one end flared to connect to a ten pin edge connector. At the other end were four solder contacts to accept the sample. Four circuit board runs were used instead of wires. The width of the probe was just wide enough to fit into the dewar between the magnet pole pieces.

4. Constant Current Power Supply

A power supply was needed that would not change current more than approximately one percent with changing loads, since current fluctuations might be read as a Hall current, leading to improper mobility and carrier concentration values. It was also necessary to use small currents to prevent sample heating. A simple power supply was constructed which utilized a 5 volt regulator with a 1 Meg ohm resistor in series with the load at the output. The resistance of a CdTe sample is on the order of 1-10 ohms. Any change in the load from a dead short to 100 ohms would not change the current by 1 percent because of the high 1 Meg ohm series resistance. A 1000 ohm resistor was also added in series to allow the use of a millivoltmeter instead

basic programming language. It was able to be interfaced through the HP-IB interface system to the Hewlett Packard HP-3478A multimeters. The intent of the program was to aid the operator with numerous prompts to give an error free "cookbook" Hall measurement.

The program has two sections and two measuring subroutines. Section one determines the sample resistivity. The program prompts the operator to select the appropriate switch on a switchbox and will measure the sample voltage and current when directed by the operator. The second part of the program determines the sample's Hall parameters. The operator is prompted to energize the Hall magnet, to select switches and to change the direction of the magnetic field as necessary. Two nearly identical subroutines are used to measure the sample voltage and current. The meters are interrogated ten times at one second intervals and the results averaged to limit measurement noise. A listing of the Hall program is included in Appendix A.

2. Hall Switchbox

A switchbox is needed to reverse the power supply polarity and to select the proper lead positions for the current meter and the voltmeter. A simple design using three DPDT toggle switches was used. The switchbox has input posts for the milliammeter, millivoltmeter and power supply. Four color coded output posts are used for the Hall

III. THE EXPERIMENT

This chapter includes a detailed description of the laboratory apparatus designed and built for the radiation experiments on CdTe and the experimental procedure.

A. EXPERIMENTAL APPARATUS

Several items, including a switchbox, constant current power supply, and a Hall probe, had to be constructed to permit the making of van der Pauw measurements. A variable temperature dewar was also needed for resistivity versus temperature measurements. This section also gives a brief description of the linear accelerator and the cadmium telluride samples.

1. Semi-automated Hall Measurement Program

The van der Pauw Hall experiment done manually involves numerous meter readings, a rather long datasheet, and several wiring changes which must be done repetitively. The resistivity measurement might be repeated twenty times for measurements over a range of temperatures. The potential for mathematical error due to the tedium of the experiment and its step by step repetitive nature makes this procedure an ideal one for computer aided measurements.

A Hewlett Packard HP-85 computer was selected due to its availability and ease of programming. The machine has a built-in data cassette for program storage and a built-in

The drift velocity, v_d , divided by the semiconductor length, L , is the transient time of the carrier. It is clear that if the lifetime is decreased, so is the gain of the device.

This chapter has shown that radiation induced defects will cause trapping sites to be introduced into a sample of CdTe. These defect levels will change the measurable parameters of the material. Devices manufactured using bulk materials such as CdTe, which are exposed to radiation environments will have their operating characteristics changed. Lifetimes of carriers are a very important parameter, however, for CdTe they are too short to be measured. The Hall parameters discussed in this chapter, on the other hand, can easily be determined using the van der Pauw method. Chapter III discusses an experiment that measures the electrical properties of a CdTe sample.

$$\tau_n = \frac{1}{Nt v_{th} \sigma_n} \quad \text{and} \quad \tau_p = \frac{1}{Nt v_{th} \sigma_p} \quad (28)$$

Notice that lifetimes are inversely proportional to the number of trapping sites, Nt . Radiation induced damage causes defects which add trapping sites to the material and therefore decrease the lifetime.

Lifetime is an important parameter for diodes, photodiodes, transistors and other devices not discussed in this paper. Lifetime for the photoconductor will be mentioned to complete the discussion. The number of carriers (n), created in a unit volume from incident photons from a pulse of light is determined by the exponential relationship in equation (29).

$$n = n_0 e^{-\frac{t}{\tau}} \quad (29)$$

The photon flux is given by the pre-exponential value n_0 . The carriers decay exponentially with time, t , divided by the lifetime, τ . Therefore if the lifetime is decreased, so will be the number of carriers. Sze defines the photocurrent gain to be [Ref. 19]:

$$\text{gain} = (\tau v_d)/L \quad (30)$$

IV. DATA and RESULTS

An experiment was completed in which the resistivity versus temperature was measured for a sample of CdTe before and after irradiation with high energy electrons. A photoluminescence study was also completed comparing an unirradiated sample and the sample radiated with 10^{15} electrons/cm². The data is presented and discussed in this chapter.

A. ELECTRICAL DATA

A CdTe sample was irradiated with 30 MeV electrons at fluences of 10^{13} , 10^{14} , and 10^{15} electrons/cm². Resistivity versus temperature data was taken after each irradiation at temperatures between approximately 100 and 200 K using standard van der Pauw methods. Hall measurements were done at 77 K and at room temperature to determine carrier concentration and resistivity before irradiation and after the last irradiation. The data for the pre-irradiation and post-irradiation Hall measurements at 77 K and room temperature are included in Table 2 and Table 3, respectively. The data for 10^{12} electrons/cm² is not included because no change over the preirradiation data was observed. Fig. 11 shows resistivity versus temperature data prior to the irradiation, and following irradiation with

TABLE 2. 77 K HALL DATA

	Pre-Irradiation	Post-Irradiation
Hall Coefficient (cm ³ /coulomb)	10300	16000
Mobility (cm ² V ⁻¹ Sec ⁻¹)	4640	4100
Carrier Concentration (cm ⁻³)	6.07 x 10 ¹⁴	3.90 x 10 ¹⁴
Resistivity (Ω-cm)	2.22	3.92

TABLE 3. 300 K HALL DATA

	Pre-Irradiation	Post-Irradiation
Hall Coefficient (cm ³ /coulomb)	9590	15,300
Mobility (cm ² V ⁻¹ Sec ⁻¹)	714	714
Carrier Concentration (cm ⁻³)	6.52 x 10 ¹⁴	4.09 x 10 ¹⁴
Resistivity (Ω-cm)	13.44	21.40

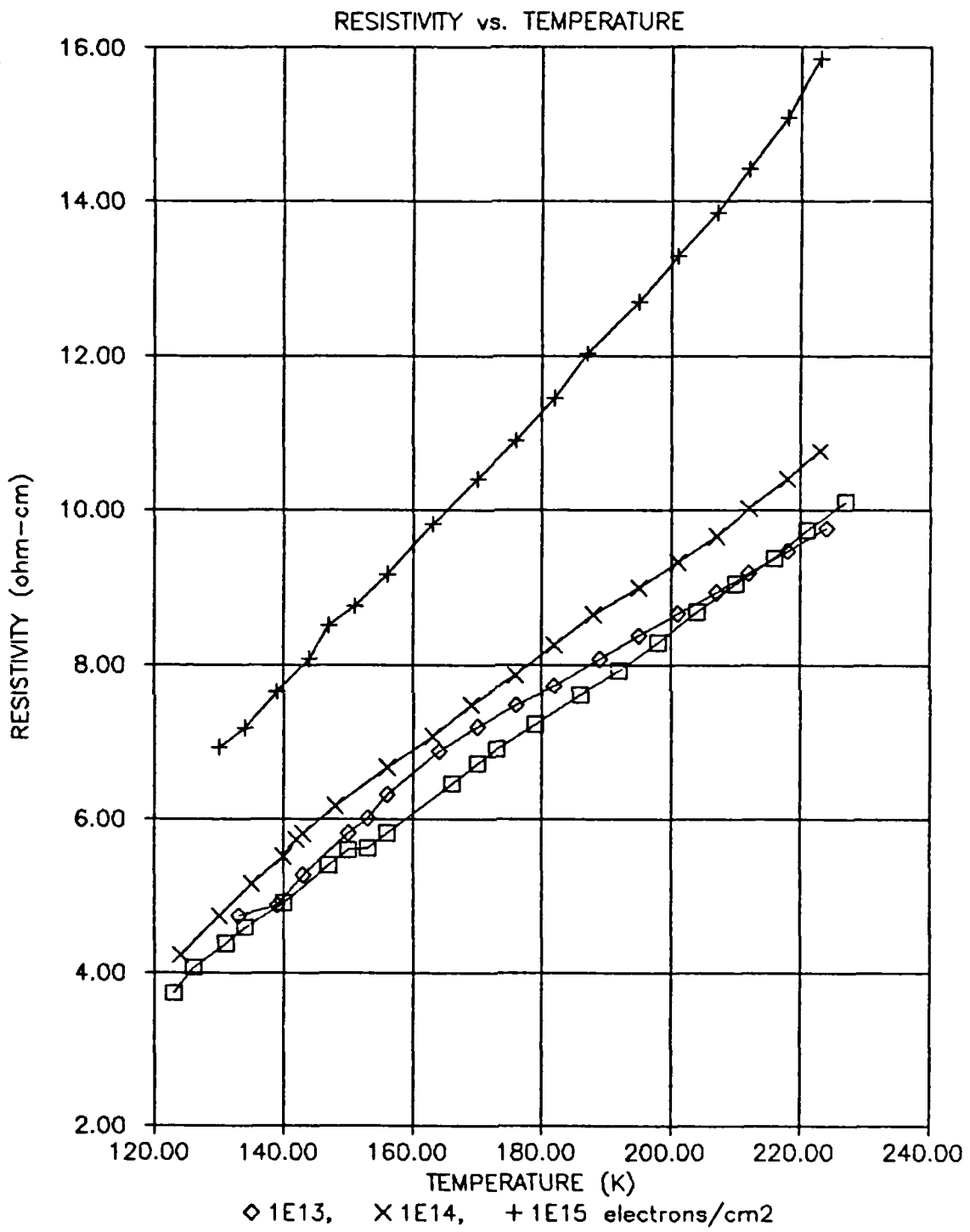

Figure 11. Resistivity vs. Temperature.

10^{13} , 10^{14} , and 10^{15} electron/cm². These results are discussed in the following section.

B. DISCUSSION of ELECTRICAL DATA

Three observations were made about the cadmium telluride sample. First, an increasing resistivity with temperature was noted (metallic behavior) which seemed unusual for a semiconductor. Secondly, an increase in resistivity was noted with increasing electron dose. Finally there existed possible evidence of annealing in one of the radiation curves.

1. Resistivity Increasing With Temperature

While preparing the sample for irradiation, it was noticed that the resistivity of the sample increased with temperature. See Fig. 11. In Table 2 note that the pre-irradiation resistivity at 77 K is 2.22 ohm-cm, and the 300 K resistivity is 13.44 ohm-cm. This was surprising in light of Equations 31 and 32 as explained below. The resistivity for an n type sample is given by:

$$\rho(T) = \frac{1}{q \mu_n(T) n(T)} \quad (31)$$

The value of the carrier concentration in an intrinsic semisemiconductor is determined from Equation 32.

$$n(T) = N_c \exp\left[-\frac{(E_c - E_f)}{KT}\right], \quad N_c = 2 \left(\frac{2\pi m_n^* KT}{h^2}\right)^{1.5} \quad (32)$$

m_n^* is the effective mass of an electron and K is the Boltzmann constant. $E_f - E_c$ is the difference in energy between the fermi level and the energy of the conduction band. Eq. 32 indicates that n should increase exponentially with increasing temperature. This would cause the resistivity, Eq. 31, to decrease with increasing temperature which is the opposite of what was observed.

The reason for this behavior became obvious after analyzing the Hall data. From Tables 2 and 3 note that the majority carrier concentration changed less than 8% (6.0×10^{14} to 6.5×10^{14}). On the other hand, the Hall data at 77 K shows the mobility to be 4640 $\text{cm}^2/\text{V}\cdot\text{s}$. At 300K the mobility is 714 $\text{cm}^2/\text{V}\cdot\text{s}$. The mobility decreases by a factor of about 7 as the sample is warmed. Therefore in Equation 31 it was noted that the mobility is dominant over the carrier concentration for this sample at the temperatures measured. This is consistent with an extrinsic semiconductor where the carrier concentration is controlled by the dopant or defect concentration rather than the intrinsic carrier concentration.

Barnes irradiated an n type sample of CdTe with thermal neutrons in 1967. His sample exhibited exactly the same resistivity behavior over the same temperature range. [Ref. 10]. His sample was an "undoped n type" sample ($n = 2 \times 10^{15}$ electrons/ cm^3) which was cut from a crystal ingot. The n type sample used in this thesis was produced by

epitaxy and had a carrier concentration of approximately 6×10^{14} electrons/cm³.

2. Radiation Effect on Resistivity and Mobility

Fig. 11 illustrates the change in resistivity with temperature for the cadmium telluride sample. The resistivity increases with each radiation. Again the Hall data, Tables 2 and 3 explain why. The carrier concentration at 77 K decreases from 6.07×10^{14} to 3.9×10^{14} after irradiation with approximately 10^{15} electrons/cm². The decrease in carrier concentration caused an increase in resistivity by equation (31), from 2.22 ohm-cm. to 3.97 ohm-cm. It is hypothesized that the carrier concentration decreases because radiation damage causes trapping sites that remove electron carriers from the conduction band. Barnes in his work with neutron radiation identifies the defect as cadmium vacancies that act as acceptors [Ref. 10]. The effect of radiation on mobility is discussed next.

A second observation of the post irradiation Hall data is that the mobility for the carriers at 77 K decreased from 4640 to 4100 cm²/V-s but did not change at all at 300 K (714 cm²/V-s). The decrease of approximately 11% at 77 K is considered significant. The mobility decreases because the number of scattering centers at 77 K increases and therefore the time between collisions decreases. See Equation 4. Barnes [Ref.10] reasons that mobility is insensitive at high temperatures to radiation because lattice scattering

dominates at high temperatures while ionized scattering centers dominate at lower temperatures.

3. Annealing at 160 K

An interesting third observation was noticed in a plot of the log resistivity versus inverse temperature as shown in Fig. 12 for the 10^{13} electron/cm² curve. The resistivity increases above pre-irradiation levels and then at about 160 K starts to decrease again. By the time the temperature reaches 230 K no change in resistivity over the pre-irradiated value exists. Is there annealing or healing of defects at higher temperatures causing this bow in the graph? Bryant et. al. observed annealing of defects at temperatures of about 110-140 K [Ref. 3]. A log log plot was constructed (Fig. 13) to try to see if the curve for 10^{13} e/cm² could be due to a temperature power law. Fig. 13 still showed a slight knee in the curve suggesting that it was not. Another observation is that, if we were looking at annealing of damage, the curve should have a higher resistivity at the lowest temperature, i.e., the preirradiation curve and the 10^{13} curve should not intersect at coldest temperatures. It is possible that this effect is due to annealing, however, more study is necessary over a broader range of temperatures to better distinguish between the various functional forms of the data.

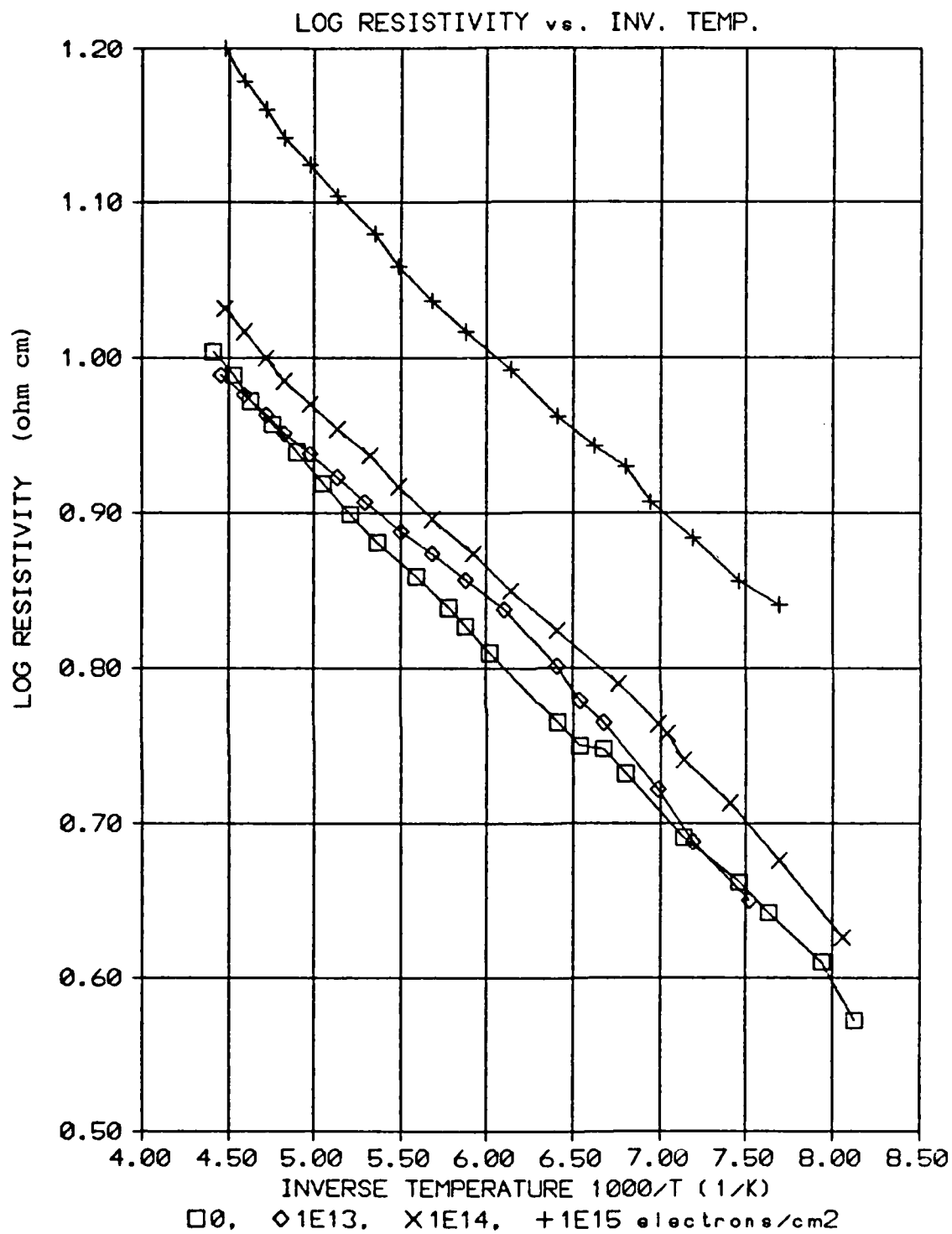

Figure 12. Log Resistivity vs. Inverse Temperature.

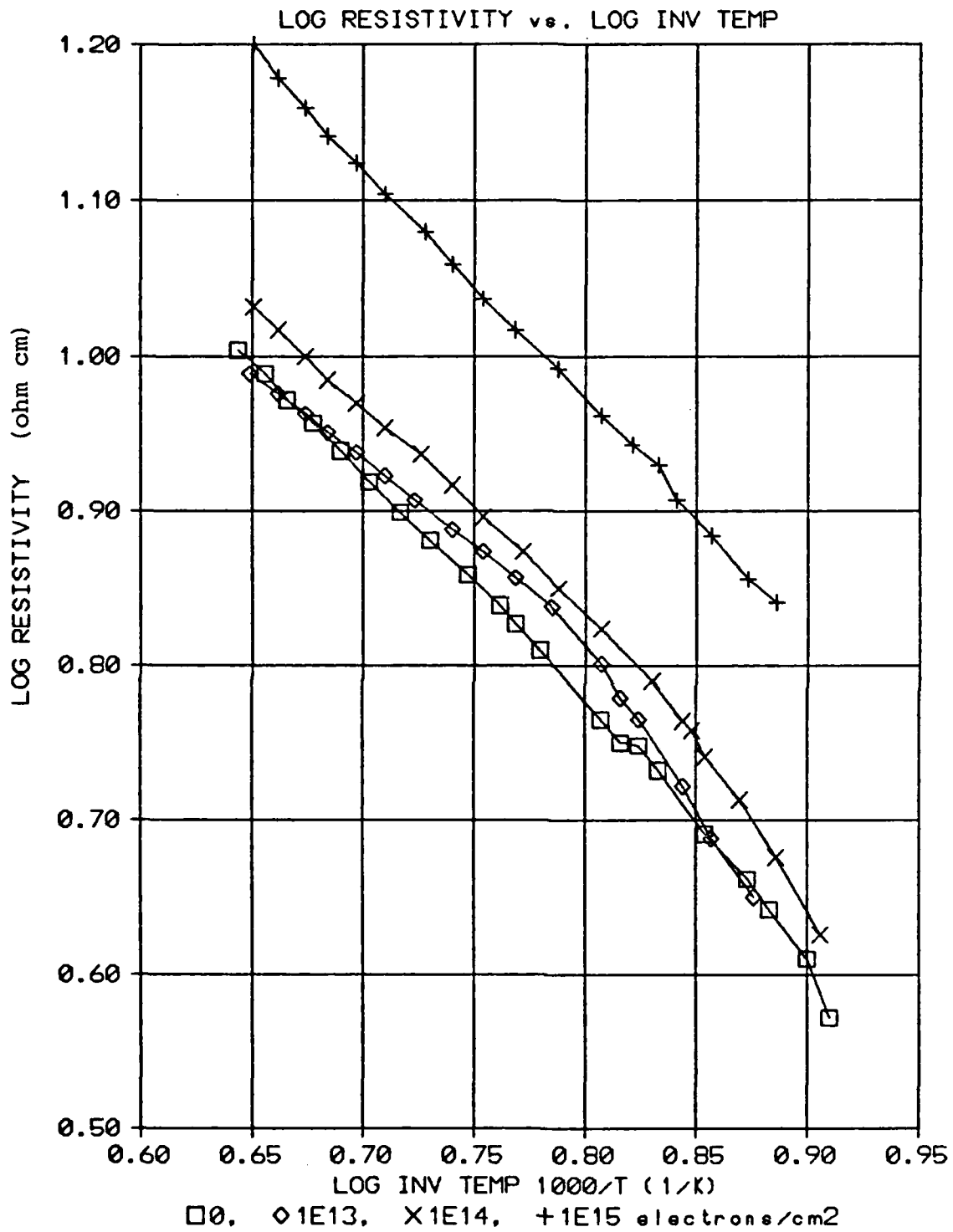

Figure 13. Log Resistivity vs. Log Inverse Temperature.

C. PHOTOLUMINESCENCE DATA AND DISCUSSION

Defects caused by radiation damage can be studied by the use of photoluminescence measurements. These measurements yield information about the relative intensities and wavelengths of photons emitted from excited samples. Photoluminescence spectrum measurements were made by Dr. J. Bajaj at Rockwell Science Center on the irradiated sample of CdTe and on a non-irradiated sample from the same batch. This was done approximately three weeks after the irradiation. The samples were excited by an argon laser and the emission spectrum was recorded on a chart recorder. The photoluminescence results are shown in Fig. 14 for the non-irradiated sample and in Fig. 15 for the irradiated sample. The photoluminescence spectrum of CdTe has an intrinsic excitonic peak and a broad maximum associated with defects. The sample irradiated with 10^{15} electrons/cm² had a defect maximum which was about twice the amplitude of the nonirradiated sample. It is obvious that damage occurred and that not all the damage annealed at 300 K since these measurements were conducted approximately three weeks after irradiation.

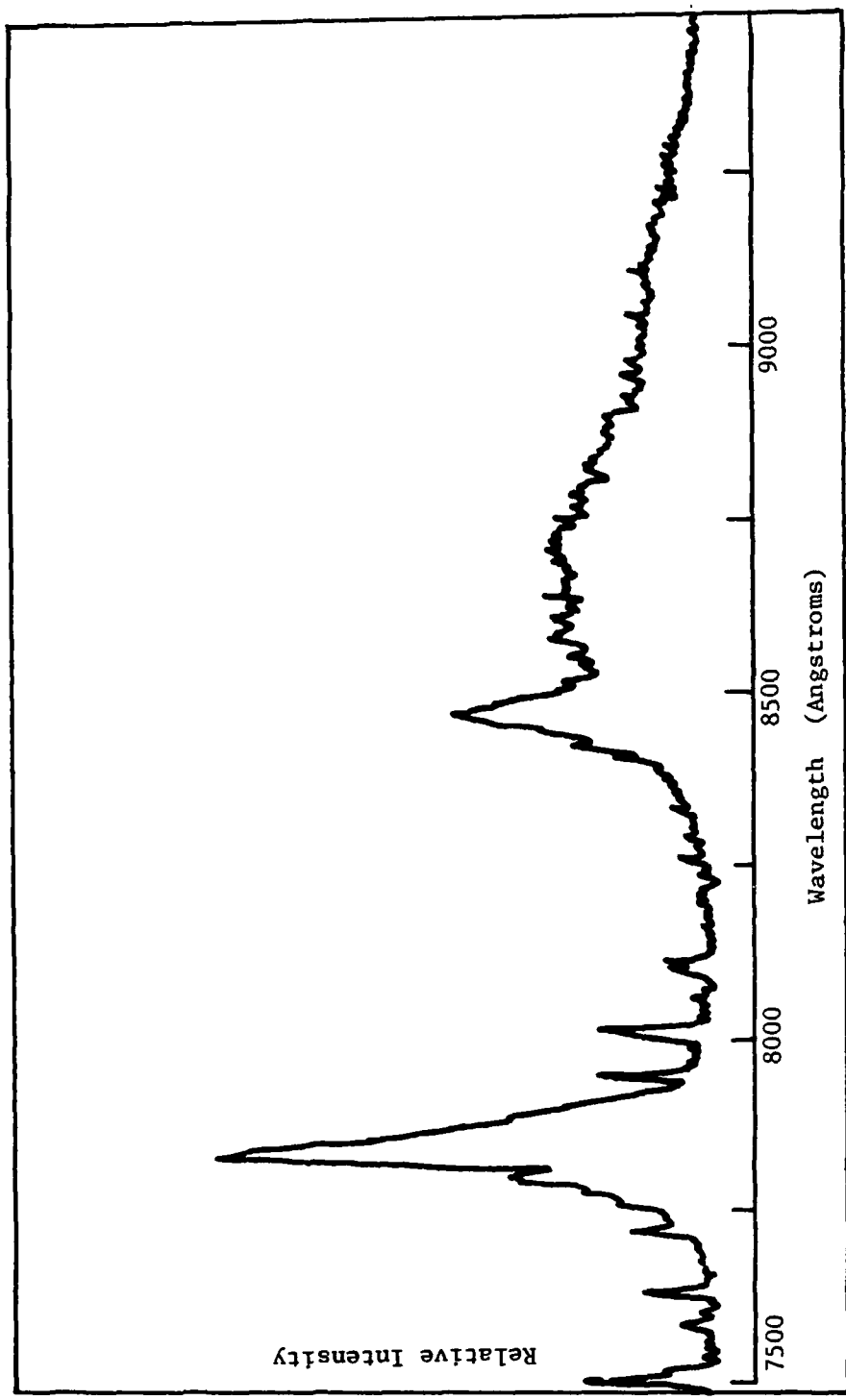

Figure 14. Photoluminescence Spectrum of the Non-irradiated Sample.

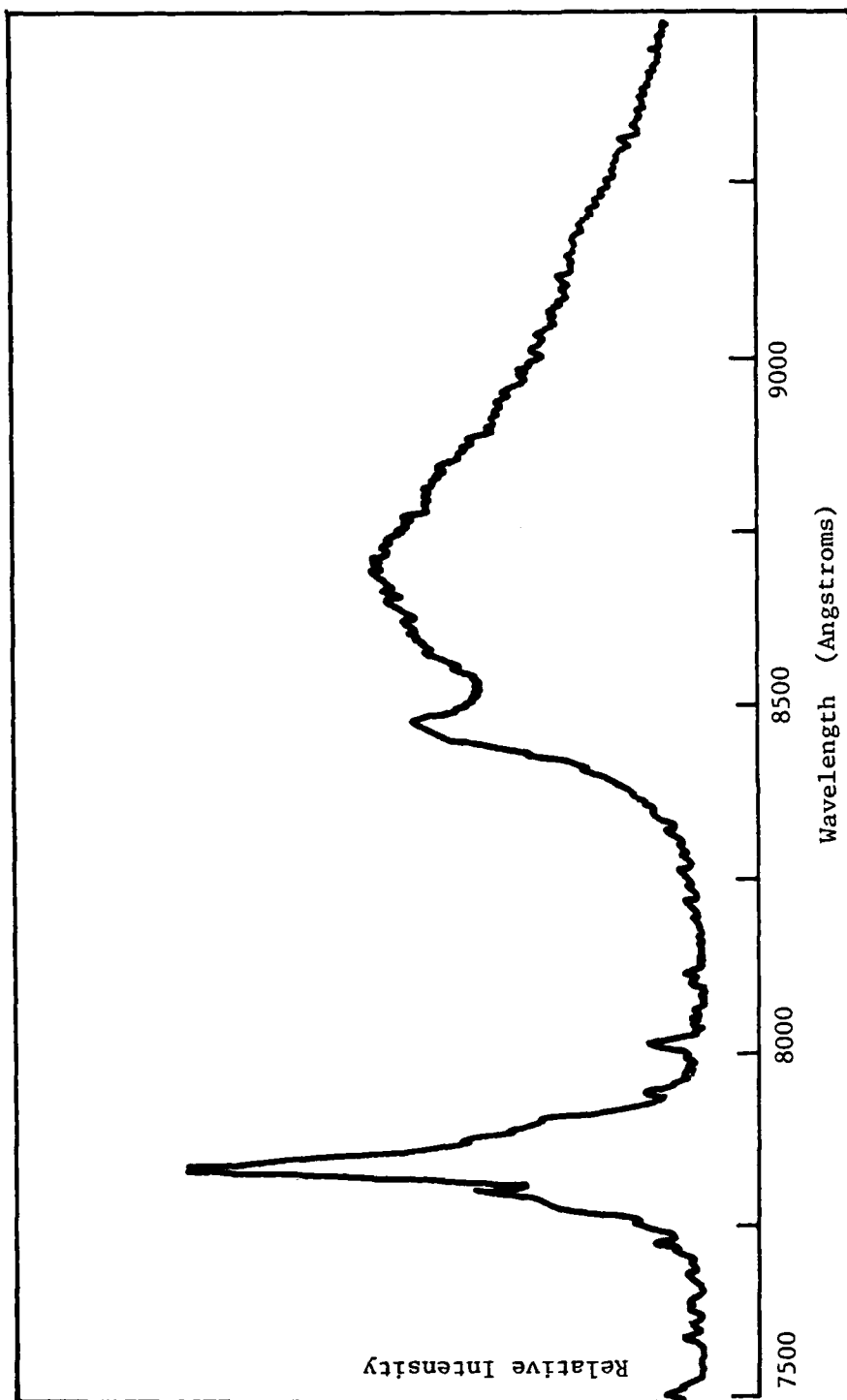

Figure 15. Photoluminescence Spectrum of the Irradiated Sample.

V. CONCLUSIONS

The history of radiation studies has given some insight into the complexity of radiation induced damage in CdTe lattices. Renewed interest in CdTe because of HgCdTe IR detectors has necessitated the need for more studies. To complete this study it was necessary to design and build the laboratory experiment which was described in chapter 3. The apparatus was constructed and a sample of CdTe was irradiated. Resistivity versus temperature data as well as Hall data confirm a change in electrical properties of the sample. A decrease in both the majority carrier concentration and the mobility caused an increase of the sample's resistivity. A photoluminescence study also shows an increase in defects caused by the electrons.

This paper has shown damage in a sample of CdTe introduced by high energy electrons. Although the experiment did yield much useful information, the defects associated with the irradiation of cadmium telluride are difficult to define using only Hall measurements.

A refinement of this experiment would be to install a Hall magnet into a more modern target chamber with a commercial variable temperature dewar with a cold finger exposed to the electron beam. The experimentalist could then measure mobility verses temperature while the sample is

in the target chamber. The mobility component of the resistivity could be extracted and the activation energy of defect centers determined. Carrier concentration as a function of temperature could also be found.

Mercury cadmium telluride IR detectors are the actual devices that may be exposed to nuclear radiation and need to be studied. Study of these more complex compounds will require more sophisticated laboratory equipment and techniques if the material is to be completely understood. For example, in HgCdTe, carrier lifetime can be measured directly [Ref. 23]. The significance of this measurement was discussed in Chapter 2. For these experiments a sample is excited using infrared lasers and the emission spectra from the sample is collected by a detector. Lifetimes are measured with an oscilloscope. This technique could be used to determine lifetime degeneration with temperature and electron dose in the accelerator target chamber. As discussed in chapter 2, lifetime is very sensitive to radiation damage and is an important device parameter. Unfortunately in CdTe the lifetimes are too short to be easily measured.

The study of semiconductors is an exciting high technology area of study which has the potential for more thesis topics. The damage studies done on semiconductors will lead to a better understanding of defects which will eventually lead to an increase in sensor reliability.

APPENDIX A

COMPUTER PROGRAM FOR HALL MEASUREMENTS

```
5 REM "AUTOHALL"  
10 REM THIS PROGRAM COMPUTES HALL PARAMETERS.  
15 REM AUTOMATICALLY READS FROM HF METERS  
20 REM INPUT ONLY MILLI VOLTS OR MILLA AMPS  
30 CLEAR  
40 DISP "    HALL MEASUREMENT ROUTINE"  
50 DISP "        BY PAUL BAUER"  
60 DISP "        PART 1"  
70 DISP "    RESISTIVITY MEASUREMENT"  
80 WAIT 2500  
90 CLEAR  
100 DISP "ENTER THE DATE"  
110 INPUT A$  
120 PRINT "DATE:",A$  
130 DISP "ENTER SAMPLE TYPE"  
140 INPUT B$  
150 PRINT "SAMPLE TYPE",B$  
160 DISP "ENTER TEMP ( K )"  
170 INPUT T  
180 PRINT "TEMP (K)= ",T  
190 DISP "ENTER SAMPLE THICKNESS (CM)"  
200 INPUT D  
210 PRINT "SAMPLE THICKNESS (CM)=",D  
220 DISP "SELECT 1/H, RES, NORM"  
230 DISP "SELECT CURRENT POSITION 2"  
240 DISP "PUSH CONT TO CONTINUE"  
245 BEEP  
250 PAUSE  
260 GOSUB 2000  
270 I1=I  
280 PRINT "I (AB) (MA)=",I1  
290 GOSUB 3000  
300 V1=V  
310 PRINT "V(DC) (MV)=",V1  
320 R1=V1/I1  
330 DISP "SELECT REV, THEN PUSH CONT"  
335 BEEP  
340 PAUSE  
350 GOSUB 2000  
360 I2=I  
370 PRINT "I (AB)=",I2  
380 GOSUB 3000  
390 V2=V  
400 PRINT "V(DC)=",V2  
410 R2=V2/I2  
420 R3=(ABS(R1)+ABS(R2))/2  
430 PRINT "R(DC,AB)=",R3
```

```

440 PRINT
450 DISP "SELECT POSITION 2"
460 DISP "PRESS CONT"
465 BEEP
470 PAUSE
480 GOSUB 2000
490 I1=I
500 PRINT "I(AD)=",I1
510 GOSUB 3000
520 V1=V
530 PRINT "V(BC)=",V1
540 R1=V1/I1
550 DISP "SELECT NORMAL"
560 DISP "CONT TO CONTINUE"
565 BEEP
570 PAUSE
580 GOSUB 2000
590 I2=I
600 PRINT "I(AD)=",I2
610 GOSUB 3000
620 V2=V
630 PRINT "V(BC)=",V2
640 R2=V2/I2
650 R4=(ABS(R1)+ABS(R2))/2
660 PRINT "R(BC,AD)=",R4
670 PRINT
680 R=(R3+R4)/2
690 PRINT "R(AVG)=",R
700 PRINT
710 X=R3/R4
720 IF X<1 THEN X=1/X
730 DISP "DETERMINE F FACTOR FOR X=",X
740 INPUT F
750 PRINT "F FACTOR=",F
760 P=4.25*F*D*R
770 PRINT
780 PRINT "THE RESISTIVITY IS",P
790 PRINT "OHM-CM"
800 PRINT
810 PRINT
820 DISP "PRESS CONT TO CONTINUE"
825 BEEP
830 PAUSE
840 CLEAR
850 DISP "PART 2. HALL MEASUREMENTS"
860 DISP "ENERGIZE MAGNET"
870 DISP "SELECT NORM, 1/H, HALL"
880 DISP "PRESS CONT TO CONTINUE"

```

```

885 BEEP
890 PAUSE
900 DISP "INCREASE B FIELD TO DESIRED B"
910 DISP "INPUT B (KILOGAUSS)"
920 INPUT B
930 PRINT "PART 2, HALL MEASUREMENT"
940 PRINT
950 PRINT "B(KILOGAUSS)=",B
960 DISP "SELECT CURRENT POSITION 2"
962 DISP "PRESS CONTINUE"
964 BEEP
965 PAUSE
970 GOSUB 2000
990 PRINT "I(AC)=",I
1000 GOSUB 3000
1010 V1=V
1020 PRINT "V(BD)=",V1
1030 DISP "REVERSE MAGNETIC FIELD BY ROTATING SAMPLE"
1040 DISP "PRESS CONT"
1045 BEEP
1050 PAUSE
1060 GOSUB 3000
1070 V2=V
1080 PRINT "V(BD)=",V2
1090 DISP "SELECT REVERSE"
1100 DISP "PRESS CONT TO CONTINUE"
1105 BEEP
1110 PAUSE
1120 GOSUB 3000
1130 V3=V
1140 PRINT "V(BD)=",V3
1150 DISP "REVERSE B FIELD BY ROTATING SAMPLE"
1160 DISP "PRESS CONT"
1165 BEEP
1170 PAUSE
1180 GOSUB 3000
1190 V4=V
1200 PRINT "V(BD)=",V4
1210 V5=(ABS(V1-V2)+ABS(V3-V4))/2
1220 PRINT "DELTA V=",V5
1230 R=V5/ABS(I)
1240 PRINT "DELTA R(OHMS)=",R
1250 R5=100000*D*R/(2*B)
1260 PRINT
1270 PRINT "THE HALL RESISTIVITY IS",R5
1280 PRINT "CM3/COULOMB"
1290 PRINT
1300 U=R5/P

```

```

1310 PRINT "THE HALL MOBILITY IS",U
1320 PRINT "CM2/V-SEC"
1330 PRINT
1340 N=6.25E18/(P*U)
1350 PRINT "CARRIER CONCENTRATION=",N
1360 PRINT "CM-3"
1370 END
2000 REM THIS SUBROUTINE MEASURES CURRENT.
2010 REM THE RESULT FROM METER 722 IS PUT INTO I
2020 REM 10 VALUES ARE AVERAGED IN 10 SECONDS.
2030 REM USE VOLTMETER ACROSS A 1000 OHM RESISTER
2040 REM RESULTS ARE IN MILLAMP
2050 DISP "I'M MEASURING CURRENT"
2060 OUTPUT 722
2070 I=0
2080 FOR J=1 TO 10
2090 ENTER 722 ; I8
2100 I=I+I8
2110 WAIT 1000
2120 NEXT J
2130 I=I/10
2140 ! NEXT STATEMENT CHANGES VOLTAGE TO CURRINT ACROSS 1000 OHM
RESISTER
2150 I=I/1000
2160 ! NEXT STATEMENT CHANGES AMPS TO MILLI AMPS
2170 I=I*1000
2180 RETURN
3000 ! THIS SUBROUTINE MEASURES VOLTAGE
3010 ! THE RESULTS FROM METER 723
3020 ! 10 VALUES AVGED IN 10 SEC
3030 ! RESULT IN mV
3035 DISP "I'M MEASURING VOLTAGE"
3040 OUTPUT 723
3050 V=0
3060 FOR K=1 TO 10
3070 ENTER 723 ; V8
3080 V=V+V8
3090 WAIT 1000
3100 NEXT K
3110 V=V/10
3120 ! NEXT STATEMENT CHANGES VOLTS TO mV
3130 V=1000*V
3140 RETURN

```

LIST OF REFERENCES

1. Rudie, J.R., Principles Of Radiation Hardening, 2d ed., v. 1., Western Periodicals Co, North Hollywood, Ca., 1980.
2. Larin, F., Radiation Effects In Semiconductor Devices, Wiley, 1968.
3. Bryant, F.J. and Webster, E., "Threshold Energy for Atomic Displacement in Cadmium Telluride", Phys.Stat.Sol., v. 21, pp.315-327, 1967.
4. Abrikosov, Bankina, Poretskaya, Shelimova, Skudnova, Semiconducting II-VI, IV-VI, And V-VI Compounds., Plenum Press, 1969.
5. Zanio, K., Semiconductors And Semimetals, Cadmium Telluride, v.13, Academic Press, 1978.
6. Lorenz, M.R., Segall, B., Woodbury, H.H., "Some Properties of a Double Acceptor Center in CdTe", Physical Review, v. 134, p. A751, 4 May 1964.
7. Lorenz, M.R., Segall, B., Woodbury, H.H., "Correlation between Irradiation and Thermally Induced Defects", Physical Review, v. 132, p. 143, 1 October 1963.
8. Thomas, D.G., II-VI Semiconducting Compounds, Benjamin, Inc, 1967, Urli, N. B. "On Properties of some Defect Centers in CdTe", pp. 1335-1347.
9. Chester, R.D., "Radiation Damage in Cadmium Sulfide and Cadmium Telluride", Journal of Applied Physics, v. 38 Number 4, p. 1745, 15 March 1967.
10. Barnes, C., Kikuchi, C., "Thermal-Neutron-Induced Defects in n-Type Cadmium Telluride", Nuclear Science and Engineering, v. 31, p. 513, 1968.
11. Bryant, F., Cox, A., and Webster, E., "Atomic Displacements and the Nature of Band Edge Radiative Emission in Cadmium Telluride", J. Phys. C (Proc. Phys. Soc.), v. 1, p. 1737, 1968.
12. Bryant, F.J., Totterdell, D.H.J., "Electron Radiation Damage and the Edge Emission of Cadmium Telluride", Rad. Eff., v. 9., p. 115, 1971.

13. Abromov, A.A., Vavilov, V.S., and Vodopianov, P.N., "Radiation Effects in CdTe Induced by Thermal Neutrons and 1 MeV Electrons", Rad. Eff., v. 10, p. 107, 1971.
14. Caillot, M., "Low Temperature Annealings of the Defect Created by 1.5 MeV Electron Irradiation in n-Type CdTe", Physics Letters, v.38A, p. 2, 3 Jan 1972.
15. Tsunemasa Taguchi, Junji Shirafuji, and Yoshio Inuishi, "Gamma and Electron Radiation in CdTe", Nuclear Instruments and Methods, v. 150, p. 43, 1978.
16. Tsunemasa Taguchi and Yoshio Inuishi, "Radiation-Induced Defects and Their Annealing Behavior in CdTe", Journal of Applied Physics, v. 51(9), p. 4757, September 1980.
17. Van der Pauw, L.J., "A Method of Measuring Specific Resistivity and Hall Effect of Discs of Arbitrary Shape", Philips Research Reports, v. 13, pp. 1-9, 1958.
18. Rudie, N.J., Principles and Techniques of Radiation Hardening, 2nd ed., v. 3, p. A10, Western Periodicals Co., North Hollywood, Ca., 1980.
19. Sze, S.M., Physics of Semiconductor Devices, 2nd ed., Wiley, 1981.
20. Muller, R.S. and Kamins, T.I., Device Electronics For Integrated Circuits, Wiley, 1977.
21. Rudie, N.J., Principles and Techniques of Radiation Hardening, 2nd ed., v. 2, pp. 14-38, Western Periodicals Co., North Hollywood Ca., 1980.
22. Waller, L., "Sapphire Substrates Improve HgCdTe Infrared Detectors", Electronics Week, p. 19, September 3, 1984.
23. Feldman, J.F., Bajaj, J., and Shin, S.H., "Photo-Luminescence in Liquid Phase Epitaxially Grown HgCdTe", Journal Applied Physics, v. 55, p. 3873, 15 May 1984.

INITIAL DISTRIBUTION LIST

	No. Copies
1. Defense Technical Information Center Cameron Station Alexandria, Virginia 22314	2
2. Library, Code 0142 Naval Postgraduate School Monterey, California 93943	2
3. Dr. K. C. Dimiduk, Code 61Dm Physics Department Naval Postgraduate School Monterey, California 93943	6
4. Dr. D. L. Walters, Code 61We Physics Department Navak Postgraduate School Monterey, California 93943	1
5. Dr. K. E. Woehler, Code 61Wh Physics Department Naval Postgraduate School Monterey, California 93943	1
6. Dr. G. E. Schacher, Code 61Sq Physics Department Naval Postgraduate School Monterey, California 93943	2
7. Dr. Paul Newman, Manager Materials Development Technology Science Center, 1049 Camino Dos Rios P.O. Box 1085, Thousand Oaks, Ca 91360	2
8. Dr. Frank Junga Lockheed Palo Alto Research Laboratory Palo Alto, California 94304	2
9. Director SSPD, Code 27301 Department of the Navy Washington, D.C. 20376	1

END

FILMED

8-85

DTIC