

MICROCOPY RESOLUTION TEST CHART
NATIONAL BUREAU OF STANDARDS 1963 A

7

MERRIMACK RIVER BASIN
NASHUA, NEW HAMPSHIRE

AD-A156 125

HARRIS POND DAM
NH 00122
NHWRB 165.05

PHASE I INSPECTION REPORT
NATIONAL DAM INSPECTION PROGRAM



DTIC
ELECTRONIC
JUL 08 1985
S D
G

DEPARTMENT OF THE ARMY
NEW ENGLAND DIVISION, CORPS OF ENGINEERS
WALTHAM, MASS. 02154

DISTRIBUTION STATEMENT A
Approved for public release
Distribution Unlimited

FEBRUARY 1979

DTIC FILE COPY

85 06 13 093

UNCLASSIFIED

SECURITY CLASSIFICATION OF THIS PAGE (When Data Entered)

REPORT DOCUMENTATION PAGE		READ INSTRUCTIONS BEFORE COMPLETING FORM
1. REPORT NUMBER NH 00122	2. GOVT ACCESSION NO.	3. RECIPIENT'S CATALOG NUMBER
4. TITLE (and Subtitle) Harris Pond Dam NATIONAL PROGRAM FOR INSPECTION OF NON-FEDERAL DAMS		5. TYPE OF REPORT & PERIOD COVERED INSPECTION REPORT
7. AUTHOR(s) U.S. ARMY CORPS OF ENGINEERS NEW ENGLAND DIVISION		6. PERFORMING ORG. REPORT NUMBER
9. PERFORMING ORGANIZATION NAME AND ADDRESS		8. CONTRACT OR GRANT NUMBER(s)
11. CONTROLLING OFFICE NAME AND ADDRESS DEPT. OF THE ARMY, CORPS OF ENGINEERS NEW ENGLAND DIVISION, NEDED 424 TRAPELO ROAD, WALTHAM, MA. 02254		10. PROGRAM ELEMENT, PROJECT, TASK AREA & WORK UNIT NUMBERS
14. MONITORING AGENCY NAME & ADDRESS (if different from Controlling Office)		12. REPORT DATE February 1979
		13. NUMBER OF PAGES 58
		15. SECURITY CLASS. (of this report) UNCLASSIFIED
		15a. DECLASSIFICATION/DOWNGRADING SCHEDULE
16. DISTRIBUTION STATEMENT (of this Report) APPROVAL FOR PUBLIC RELEASE: DISTRIBUTION UNLIMITED		
17. DISTRIBUTION STATEMENT (of the abstract entered in Block 20, if different from Report)		
18. SUPPLEMENTARY NOTES Cover program reads: Phase I Inspection Report, National Dam Inspection Program; however, the official title of the program is: National Program for Inspection of Non-Federal Dams; use cover date for date of report.		
19. KEY WORDS (Continue on reverse side if necessary and identify by block number) DAMS, INSPECTION, DAM SAFETY, Merrimack River Basin Nashua New Hampshire Pennichuck Brook		
20. ABSTRACT (Continue on revc so side if necessary and identify by block number) TXe dam is a 450 ft. long, 35 ft. high earthfill dam with cemented rubble stone masonry core walls. The dam is intermediate in size with a significant hazard potential. The test flood is taken as 1/2 of the PMF. Generally the dam is in fair condition.		

DISCLAIMER NOTICE

**THIS DOCUMENT IS BEST QUALITY
PRACTICABLE. THE COPY FURNISHED
TO DTIC CONTAINED A SIGNIFICANT
NUMBER OF PAGES WHICH DO NOT
REPRODUCE LEGIBLY.**

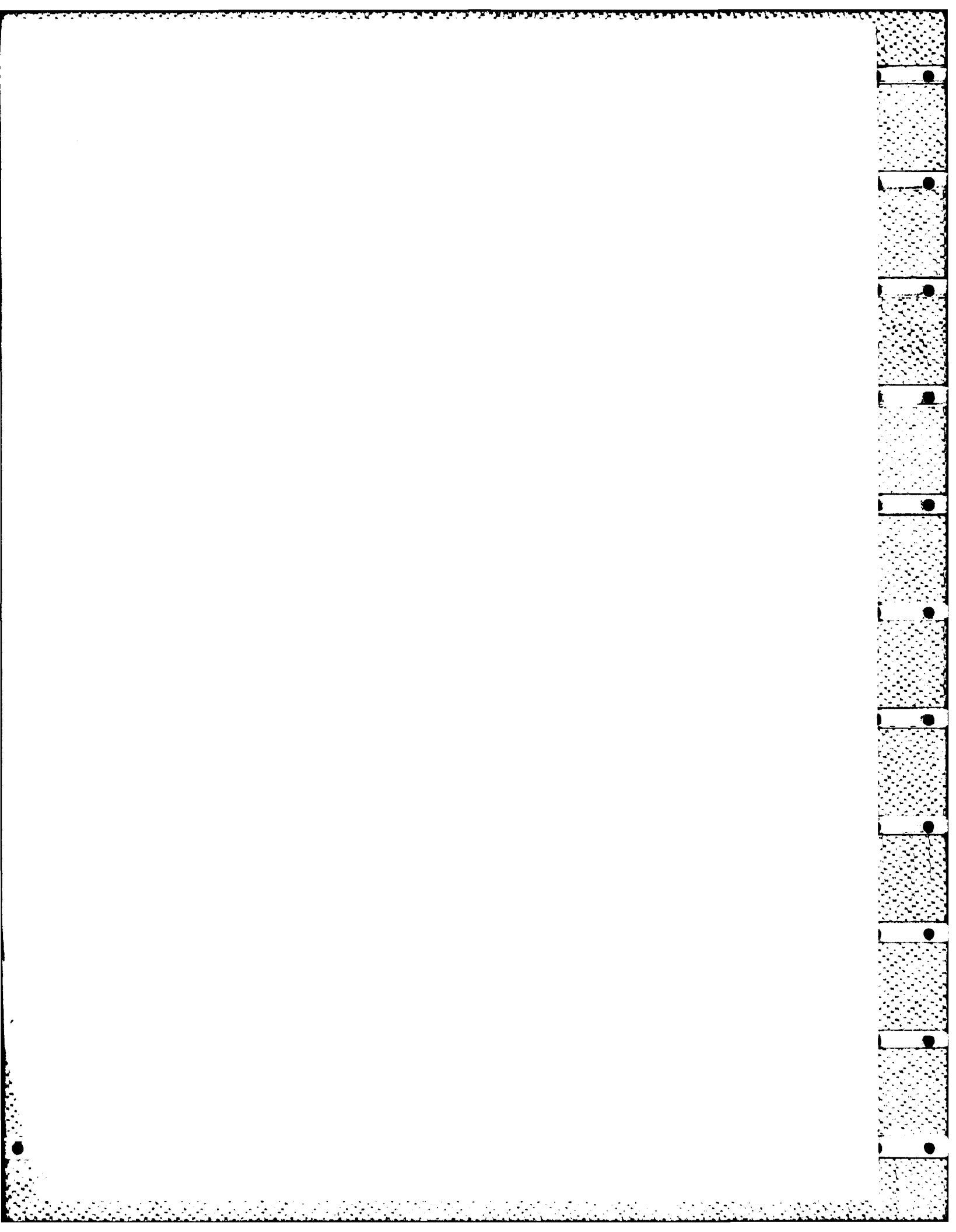



DEPARTMENT OF THE ARMY
NEW ENGLAND DIVISION, CORPS OF ENGINEERS
424 TRAPELO ROAD
WALTHAM, MASSACHUSETTS 02154

REPLY TO
ATTENTION OF:
NEDED

MAY 29 1979

Honorable Hugh J. Gallen
Governor of the State of New Hampshire
State House
Concord, New Hampshire 03301

Dear Governor Gallen:

I am forwarding to you a copy of the Harris Pond Dam Phase I Inspection Report, which was prepared under the National Program for Inspection of Non-Federal Dams. This report is presented for your use and is based upon a visual inspection, a review of the past performance and a brief hydrological study of the dam. A brief assessment is included at the beginning of the report. I have approved the report and support the findings and recommendations described in Section 7 and ask that you keep me informed of the actions taken to implement them. This follow-up action is a vitally important part of this program.

A copy of this report has been forwarded to the Water Resources Board, the cooperating agency for the State of New Hampshire. In addition, a copy of the report has also been furnished the owner, Pennichuck Water Works, 11 High Street, Nashua, New Hampshire 03060.

Copies of this report will be made available to the public, upon request, by this office under the Freedom of Information Act. In the case of this report the release date will be thirty days from the date of this letter.

I wish to take this opportunity to thank you and the Water Resources Board for your cooperation in carrying out this program.

Sincerely yours,

JOHN P. CHANDLER
Colonel, Corps of Engineers
Division Engineer

Incl
As stated

HARRIS POND DAM
NH 00122

MERRIMACK RIVER BASIN
NASHUA, NEW HAMPSHIRE

Accession For	
NTIS GRA&I	<input checked="" type="checkbox"/>
DTIC TAB	<input type="checkbox"/>
Unannounced	<input type="checkbox"/>
Justification	
By _____	
Distribution/	
Availability Codes	
Dist	Avail and/or Special
A/1	23 <i>W</i>

PHASE I INSPECTION REPORT
NATIONAL DAM INSPECTION REPORT



NATIONAL DAM INSPECTION PROGRAM

PHASE I REPORT

Identification No.: NH 00122
NHWRB No.: 165.05
Name of Dam: HARRIS POND DAM
City: Nashua
County and State: Hillsborough County, New Hampshire
Stream: Pennichuck Brook
Date of Inspection: October 31, 1978

BRIEF ASSESSMENT

Harris Pond Dam is a 450 foot long, 35 foot high earthfill structure with cemented rubble stone masonry core walls, an 85 foot long arch type cemented stone masonry spillway with a concrete cap, a gate house, and an auxiliary gate house which serves the downstream water treatment plant. There is a 165 foot long, 13 foot high earthfill dike approximately 1000 feet west of the main dam. Outlet works include a 72 inch diameter penstock which feeds the downstream water treatment plant, a 60 inch diameter conduit, two 18 inch diameter waste gates at the dam, and one 12 inch diameter outlet pipe at the west dike. The dam is owned by the Pennichuck Water Works. While a dam has existed at this site since 1870, alterations in 1895 and thereafter brought the dam and west dike to their present configuration.

The dam, which lies on a tributary to the Merrimack River, is used for water supply. The drainage area of the structure consists of 24.7 square miles, which is primarily forested terrain. The dam's maximum impoundment of 1670 acre-feet and height of less than 40 feet places it in the INTERMEDIATE size category, while the possibility of damage to Supply Pond Dam, Nashua's water supply conduits, and the Route 3 bridge downstream, result in a SIGNIFICANT hazard potential classification.

Based on the size and hazard classification and in accordance with the Corps' guidelines, the Test Flood (TF) is taken as one half the Probable Maximum Flood, which yields a flow of 4940 cfs.

The selected TF inflow of 4940 cfs results in a discharge at the dam of 4800 cfs. If the waste gates are fully open, this discharge corresponds to a water level of 5.4 feet above the spillway crest or about 0.3 feet below the dam crest.

The dam is in FAIR condition at the present time and requires considerable routine maintenance. The owner should engage a qualified geotechnical engineer to investigate the seepage at the toe of the right embankment and design remedial measures to prevent erosion of the downstream toe. Recommended remedial measures include pointing of open joints on the spillway face, spillway abutment, and training walls; removing trees from the embankments; trimming and removing vegetation and trees in the downstream channel; instituting a program of annual technical inspections; and developing a formal warning system to alert people downstream in the event of an emergency.

The recommendations and improvements outlined above should be implemented within one year of receipt of the report by the owner.



William S. Zoino
William S. Zoino
N.H. Registration 3226



Nicholas A. Campagna, Jr.
Nicholas A. Campagna, Jr.
California Registration 21006

This Phase I Inspection Report on Harris Pond Dam has been reviewed by the undersigned Review Board members. In our opinion, the reported findings, conclusions, and recommendations are consistent with the Recommended Guidelines for Safety Inspection of Dams, and with good engineering judgment and practice, and is hereby submitted for approval.

Joseph A. McElroy

JOSEPH A. MCELROY, MEMBER
Foundation & Materials Branch
Engineering Division

Carney M. Terzian

CARNEY M. TERZIAN, MEMBER
Design Branch
Engineering Division

Joseph W. Finegan, Jr.

JOSEPH W. FINEGAN, JR., CHAIRMAN
Chief, Reservoir Control Center
Water Control Branch
Engineering Division

APPROVAL RECOMMENDED:

Joe B. Fryar

JOE B. FRYAR
Chief, Engineering Division

PREFACE

This report is prepared under guidance contained in the Recommended Guidelines for Safety Inspection of Dams for Phase I Investigations. Copies of these guidelines may be obtained from the Office of Chief of Engineers, Washington, D.C. 20314. The purpose of a Phase I Investigation is to identify expeditiously those dams which may pose hazards to human life or property. The assessment of the general condition of the dam is based upon available data and visual inspections. Detailed investigation and analyses involving topographic mapping, subsurface investigations, testing, and detailed computational evaluations are beyond the scope of a Phase I investigation; however, the investigation is intended to identify any need for such studies.

In reviewing this report, it should be realized that the reported condition of the dam is based on observations of field conditions at the time of inspection along with data available to the inspection team. In cases where the reservoir was lowered or drained prior to inspection, such action, while improving the stability and safety of the dam, removes the normal load on the structure and may obscure certain conditions which might otherwise be detectable if inspected under the normal operating environment of the structure.

It is important to note that the condition of a dam depends on numerous and constantly changing internal and external conditions, and is evolutionary in nature. It would be incorrect to assume that the present condition of the dam will continue to represent the condition of the dam at some point in the future. Only through continued care and inspection can unsafe conditions be detected.

Phase I inspections are not intended to provide detailed hydrologic and hydraulic analyses. In accordance with the established Guidelines, the Test Flood is based on the estimated "Probable Maximum Flood" for the region (greatest reasonably possible storm runoff), or fractions thereof. Because of the magnitude and rarity of such a storm event, a finding that a spillway will not pass the Test Flood should not be interpreted as necessarily posing a highly inadequate condition. The Test Flood provides a measure of relative spillway capacity and serves as an aid in determining the need for more detailed hydrologic and hydraulic studies, considering the size of the dam, its general condition and the downstream damage potential.

TABLE OF CONTENTS

	<u>Page</u>
LETTER OF TRANSMITTAL	
BRIEF ASSESSMENT	
REVIEW BOARD SIGNATURE SHEET	
PREFACE	iv
TABLE OF CONTENTS	v
OVERVIEW PHOTOS	vii
LOCATION MAP	ix
SECTION 1 - PROJECT INFORMATION	
1.1 General	1-1
1.2 Description of Project	1-2
1.3 Pertinent Data	1-6
SECTION 2 - ENGINEERING DATA	
2.1 Design Records	2-1
2.2 Construction Records	2-1
2.3 Operational Records	2-1
2.4 Evaluation of Data	2-1
SECTION 3 - VISUAL OBSERVATIONS	
3.1 Findings	3-1
3.2 Evaluation	3-3
SECTION 4 - OPERATIONAL PROCEDURES	
4.1 Procedures	4-1
4.2 Maintenance of Dam	4-1
4.3 Maintenance of Operating Facilities	4-1
4.4 Description of Warning System	4-1
4.5 Evaluation	4-1

Table of Contents - Cont.

	<u>Page</u>
SECTION 5 - HYDRAULICS/HYDROLOGY	
5.1 Evaluation of Features	5-1
5.2 Hydrologic/Hydraulic Evaluation	5-4
5.3 Downstream Dam Failure Hazard Estimate	5-4
SECTION 6 - STRUCTURAL STABILITY	
6.1 Evaluation of Structural Stability	6-1
SECTION 7 - ASSESSMENT, RECOMMENDATIONS AND REMEDIAL MEASURES	
7.1 Dam Assessment	7-1
7.2 Recommendations	7-1
7.3 Remedial Measures	7-1
7.4 Alternatives	7-2
<u>APPENDICES</u>	
APPENDIX A - VISUAL INSPECTION CHECKLIST	A-1
APPENDIX B - FIGURES AND PERTINENT RECORDS	B-1
APPENDIX C - SELECTED PHOTOGRAPHS	C-1
APPENDIX D - HYDROLOGIC/HYDRAULIC COMPUTATIONS	D-1
APPENDIX E - INFORMATION AS CONTAINED IN <u>THE NATIONAL INVENTORY OF DAMS</u>	E-1

The flared wingwall which is integrally constructed with the downstream training wall has experienced considerable unravelling. Seepage, at the rate of 10 gpm, was observed to flow through this wall.

(3) Embankment

The general condition of the embankment is good. No deficiencies in the vertical and horizontal alignment were noted. No sloughing or erosion of slopes was noted, and the condition of the abutments was good. Seepage at the rate of 5 to 10 gpm at the toe of the right embankment was noted; the water was clean and clear. Considerable heavy brush and trees up to 18 inches in diameter were noted on both the upstream and downstream slopes.

(4) Left Abutment

Loose mortar and efflorescence occurs over 50% of the wall face of the abutment and its training walls.

(5) Service Bridge

The service bridge including its protective chain link fence are in good condition.

(6) Gate House

Visual observations of the gate house indicate that this structure is in good condition. Since the representatives of the Pennichuck Water Works declined to permit access and to operate the waste gate, its function could not be observed. According to a representative of the owner, this gate is in good operating condition. This also applies to the telemetering equipment and controls at the water treatment plant.

(7) Secondary (Auxiliary) Gate House

Visual observations of this gate house indicate that the structure is in good condition.

SECTION 3 - VISUAL OBSERVATIONS

3.1 Findings

(a) General

The Harris Dam is in FAIR condition at the present time. This structure requires repointing of the open joints on the downstream face of the spillway and training walls and positive measures to control seepage through the right embankment to ensure its long-term safety and use.

(b) Dam

(1) Spillway

Observations of the cemented stone arch type spillway with its 2.9 foot high concrete cap have revealed seepage between the bottom of the concrete cap and the top of the cemented stone masonry. In some instances there is seepage through the open joints of the stone masonry. It is estimated that at least 50% of the joints in the spillway are void of mortar. The condition of the concrete cap of the spillway is good. The sluice gates are well maintained. The catwalk around the perimeter of the spillway is in good condition. This catwalk is not a debris catcher. The two-inch P.V.C. water pipe which is used to aerate the reservoir surface to prevent ice build up is broken and separated adjacent to the left abutment.

(2) Right Abutment

Loose mortar and efflorescence occurs over approximately 50% of the wall face. The abutment and the entire downstream continuation of this abutment has been faced with gunite from the channel bed to a height of approximately 15 feet. This gunite facing exhibits large, random cracks and is completely efflorescenced which can be attributed to seepage. This mortar facing was applied to the abutment and downstream training wall to arrest seepage. There is considerable amount of vegetation at the connection between the spillway and this abutment.

SECTION 2 - ENGINEERING DATA

2.1 Design Records

The design of the dam is quite simple and incorporates no unusual features except the use of an arched spillway section between the earth embankments. Drawings of the planned additions to the dam were available, and the pertinent drawings are included in Appendix B.

2.2 Construction Records

No construction records are available for the dam although the design drawings are in general agreement with the conditions observed at the site.

2.3 Operational Records

The owner operates the dam in a manner consistent with its intended purpose and engineering features.

2.4 Evaluation of Data

(a) Availability

The absence of design calculations offsets to some extent the usefulness of the design plans of the revisions to Harris Pond Dam. The general agreement between the design drawings and the conditions observed at the site result in an overall satisfactory assessment for availability.

(b) Adequacy

The lack of in-depth engineering data does not permit a definitive review. Therefore, the adequacy of the dam cannot be assessed from the standpoint of reviewing design and construction data. This assessment is based primarily on the visual inspection, past performance, and sound engineering judgment.

(c) Validity

Since the observations of the inspection team generally confirm the information contained in the design drawings, with modifications, a satisfactory evaluation for validity is indicated.

- (2) Length: 450 feet; Dike: 165 feet ±
- (3) Height: 35 feet ±; Dike: 13 feet ±
- (4) Top width: Varies, approx. 2 feet at spillway; Dike: 40 feet ±
- (5) Side slopes: Spillway - U/S 1 horizontal to 4 vertical
D/S 1 horizontal to 4 vertical
Dike: U/S 2 horizontal to 1 vertical
D/S 2 horizontal to 1 vertical
- (6) Core: Stone masonry core
- (7) Cutoff: Plans for the dike show a steel sheeting cutoff
- (8) Zoning and grout curtain: Unknown

(f) Spillway

- (1) Type: Stone masonry gravity arch
- (2) Length of weir: 85 feet
- (3) Crest elevation: 167.7 ft (MSL)
- (4) Gates: Two 18 inch pipes embedded in spillway
- (5) U/S channel: Broad approach from pond
- (6) D/S channel: Direct outlet to Supply Pond

(g) Regulating Outlets

The regulating outlets are described in paragraph b.1 of this section.

- (3) Spillway capacity at maximum pool elevation:
3630 cfs at El. 173.4
- (4) Gated capacity at recreational pool elevation:
1150 cfs at El. 167.7
- (5) Gated capacity at maximum pool elevation:
1530 cfs at El. 173.4
- (6) Total capacity at maximum pool elevation:
5160 cfs at El. 173.4

(c) Elevation (ft. above MSL)

- (1) Top of Dam: El. 173.4
- (2) Maximum pool elevation: El. 173.4
- (3) Recreational pool: El. 167 ±
- (4) Spillway crest (gated): El. 167.7
- (5) Upstream portal invert diversion tunnels:
El. 158.5 (72 inch Penstock) and El. 143.0
(60 inch waste conduit)
- (6) Streambed at centerline of dam: El. 138.7
- (7) Maximum tailwater: El. 140.9

(d) Reservoir

- (1) Length of pool - recreational: 6000 ft ±
- maximum: 6000 ft ±
- (2) Storage - recreational pool: 1190 acre-ft ±
- maximum pool: 1670 acre-ft ±
- (3) Surface area - recreational pool: 83 acres ±

(e) Dam

- (1) Type: Earth embankment with stone masonry
core wall and stone masonry arch
spillway with a concrete cap

1.3 Pertinent Data

(a) Drainage Area

Harris Pond receives runoff from 24.7 square miles of gently to steeply sloping forested terrain. Harris Pond is one of several water storage ponds located on Pennichuck Brook which combine to form the major source of the water needs provided by the Pennichuck Water Works to the city of Nashua, N.H.

(b) Discharge at Damsite

(1) Outlet Works

The dam has several outlet structures. These include the 72 inch penstock, a 60 inch waste conduit, the two 18 inch pipes poured into the concrete spillway cap, and the 12 inch pipe submerged in the west dike. The 72 inch penstock is used primarily to waste water from Harris Pond to the channel below Supply Pond Dam and to generate power for pumps used by the Pennichuck Water Works (PWW). Eventually, this penstock will be used to divert water directly from Harris Pond to the new treatment plant being constructed by PWW. The invert elevation of this pipe is El. 158.5, and the flow is controlled by means of a screw gate. The 60 inch waste conduit allows the direct flow of water from Harris Pond to Supply Pond beneath the dam. It is controlled by a screw gate and has an invert elevation of 143.0. The two 18 inch diameter pipes in the spillway cap are controlled by means of lift gates and have invert elevations of approximately 165.0. The 12 inch pipe in the west dike is controlled by a screw gate although it is left permanently open. The invert elevation of the pipe is El. 164.4.

(2) Maximum Known Flood

Water level readings in January, February, and March 1936 are on file with the New Hampshire Water Resources Board. At that time the concrete cap was not in place but 2.5 feet of flashboards were across the spillway. The maximum water level was recorded on March 20, 1936 and was approximately 1.5 feet above the flashboards or about 4.7 feet below the top of the dam.

(g) Purpose of Dam

At present, the dam is being used primarily to retain water used by the Pennichuck Water Works to supply the city of Nashua, N.H. Water from Harris Pond flows into Supply Pond where it is removed for use in the water supply system. Water can be taken directly from Harris Pond for water supply by use of the 6 foot penstock described previously. This penstock is also used to generate power for pumping at Pump Station No. 4 located just downstream from the Supply Pond Dam. The power generation is dependent upon the amount of water that needs to be drained from Harris Pond to maintain its desired level.

(h) Design and Construction History

Available records indicate that the dam and appurtenances were originally constructed around 1870, reconstructed in 1895 with further reconstructions made during the life of the dam. The earth fill dike with the stone masonry core wall was constructed as part of the 1895 improvement program. The 1895 improvement program consisted of raising the crest elevation of the spillway, the dam (including abutments), and the west dike by 5 feet. A more recent improvement (since 1973) was the removal of flashboards and the construction of a concrete cap which now serves as the spillway crest. This cap resulted in approximately a 3 foot increase in the permanent spillway height. Two 18 inch diameter waste gates were installed within this concrete cap.

(i) Normal Operational Procedure

The elevation of Harris Pond is kept at approximately elevation 167 MSL (Mean Sea Level). As the water level in the dam rises the 6 foot (72") penstock running to Pump Station No. 4 located just downstream of Supply Pond Dam (NH 00123) is opened to waste water or to generate power for pumping. The two 18 inch pipes in the concrete spillway cap are also used to control the flow into Supply Pond. Therefore, by opening the 72 inch penstock when the water level rises, the water level in Harris Pond is kept relatively constant (at least during periods where flow exceeds water usage in Nashua). The levels of Harris Pond and Supply Pond are monitored daily during the week and on weekends during periods of high flow. For this reason, water rarely flows over the spillway at either dam.

Steps from the interior of the gate house to the platform provide access for maintenance. This structure houses a timber sluice gate operated between "Z" shaped steel guides. This sluice gate is the inlet for the 6 foot diameter penstock which discharges in the pump house adjacent to Supply Pond Dam (NH 00123). Because of the lack of access the size of the gate could not be determined. A 30 inch diameter cast iron riser pipe with a bolted cover projects 3 feet above the ground approximately 5 feet downstream of this gate house. It appears that this riser pipe is an observation manhole located over the penstock. Two training walls extend upstream from the gate house into the reservoir. The left wall is perpendicular to the face of the structure, whereas the right hand wall is splayed at approximately a 45° angle. The walls consist of cemented stone masonry with square cut granite capstone.

(c) Size Classification

The dam's maximum impoundment of 1670 acre-feet falls within the 1000 to 50,000 acre-foot range which defines the INTERMEDIATE size category as defined in the "Recommended Guidelines."

(d) Hazard Potential Classification

A failure of Harris Pond Dam would result in property damage to Supply Pond (NH 00123), water supply conduits carrying water for Nashua, N.H., and the Route 3 bridge over Pennichuck Brook downstream from Supply Pond Dam. Since the structures are not normally occupied, the chance for loss of life in the event of a dam failure is low. For these reasons, a SIGNIFICANT hazard potential classification is warranted.

(e) Ownership

The Pennichuck Water Works owns this dam. The Pennichuck Water Works has offices at 11 High Street, Nashua, N.H. 03060.

(f) Operator

The Pennichuck Water Works operates the structure. Personnel involved in the operation of the dam are Steve Gorman, V.P., who can be reached by telephone at 603-882-5191, and Steve Scully who can be reached at 603-882-1391.

The right abutment consists of random cemented stone masonry and extends upstream into the reservoir; its downstream extension serves as a training wall. This stone abutment and training wall is approximately 4.5 feet wide at its top surface and has a front batter of approximately 3 horizontal to 12 vertical. The left abutment, which consists of random cemented stone masonry, is constructed in a configuration of a "Z". The outstanding legs form the upstream and downstream end walls. The abutment is approximately 4.5 feet wide at its top surface; the front batter of this abutment and training walls is similar to the right abutment. A wood framed gate house is located on the upstream side of the "Z".

The wood framed gate house contains two cast iron sluice gates and a water level sensing device. The right gate serves as the outlet for a 5 foot diameter waste conduit which penetrates through the left downstream training wall at a sharp skew. The left gate, which has been sealed, served as the inlet to a 5 foot diameter penstock to a former pumping station which was located on the left bank approximately 100 feet downstream of the gate house. This pumping station has been demolished. A water level sensing device, which is monitored at the water treatment plant adjacent to the Supply Pond Dam (NH 00123) by means of a telemetering system, is located between the gates. A vertical steel trash rack is located on the approach to the sealed penstock gate.

A structural steel service bridge with a 3 inch timber deck spans between both training walls downstream of the spillway. This structure is supported with bearings located at the top of the downstream training walls and also with diagonal bents framing approximately at 45° angle into both of these walls. There is a chain link fence around the perimeter of the service bridge and up to the ends of the abutment with an access gate to the approach of the spillway catwalk.

A secondary (auxiliary) gate house is located approximately 100 feet to the left of the gate house adjacent to the spillway. The size of this gate house is approximately 10 feet x 20 feet. This structure is equipped with a sloping trash rack on its upstream face which is supported by a timber platform.

1.2 Description of Project

(a) Location

The Harris Pond Dam lies on the Pennichuck Brook approximately 5 miles north of the center of the city of Nashua, New Hampshire. The dam is located approximately 2500 feet upstream from the point where U. S. Route 3 crosses Pennichuck Brook. The dam is accessible from Route 3 via an access road leading to the Pennichuck Water Works' Snow Plant. The access road continues from the Snow Plant to Harris Dam. The portion of the USGS Nashua North, N.H. quadrangle presented previously shows this locus. Figure 1 of Appendix B presents a detail of the site developed from the inspection visit and the map.

(b) Description of Dam and Appurtenances

The dam and appurtenances consist of an earth filled dam with cemented rubble stone masonry core walls, an arch type cemented stone masonry spillway with a concrete cap, a gate house, and an auxiliary gate house serving the water treatment plant located approximately 1500 feet downstream of the structure in the vicinity of Supply Pond Dam (NH 00123).

The total length of the dam is approximately 450 feet. In addition, an earth fill dike with a cemented stone masonry core wall was constructed approximately 1000 feet west of the main dam. This dike is approximately 165 feet long. This dike has two outlet structures, one structure equipped with a rectangular vertical lift gate and the other apparently sealed.

The arched spillway is approximately 85 feet long. It consists of a cemented stone masonry arch type structure with a 2.9 foot high concrete cap and sill. The concrete cap presently serves as the spillway. The overall height of the spillway structure is approximately 30 feet. The inverts of the two 18 inch outlet pipes penetrating through the spillway are approximately 2.7 feet below the spillway crest. Discharge through these pipes is controlled by sluice gates actuated with non-rising stems and operating nuts. A steel framed timber decked maintenance catwalk is located around the complete outside perimeter of the spillway. A perforated 2-inch diameter P.V.C. water pipe is supported around the catwalk; the purpose of this pipe is to aerate the reservoir surface in order to prevent ice build-up.

PHASE I INSPECTION REPORT

HARRIS POND DAM

SECTION 1

PROJECT INFORMATION

1.1 General

(a) Authority

Public Law 92-367, August 8, 1972, authorized the Secretary of the Army, through the Corps of Engineers, to initiate a national program of dam inspection throughout the United States. The New England Division of the Corps of Engineers has been assigned the responsibility of supervising the inspection of dams within the New England Region. Goldberg, Zoino, Dunicliff & Associates, Inc. (GZD) has been retained by the New England Division to inspect and report on selected dams in the State of New Hampshire. Authorization and notice to proceed was issued to GZD under a letter of November 28, 1978 from Colonel Max B. Scheider, Corps of Engineers. Contract No. DACW 33-79-C-0013 has been assigned by the Corps of Engineers for this work.

(b) Purpose

(1) Perform technical inspection and evaluation of non-federal dams to identify conditions which threaten the public safety and thus permit correction in a timely manner by non-federal interests.

(2) Encourage and prepare the states to initiate quickly effective dam safety programs for non-federal dams.

(3) Update, verify and complete the National Inventory of Dams.

(c) Scope

The program provides for the inspection of non-federal dams in the high hazard potential category based upon location of the dams and those dams in the significant hazard potential category believed to represent an immediate danger based on condition of the dam.

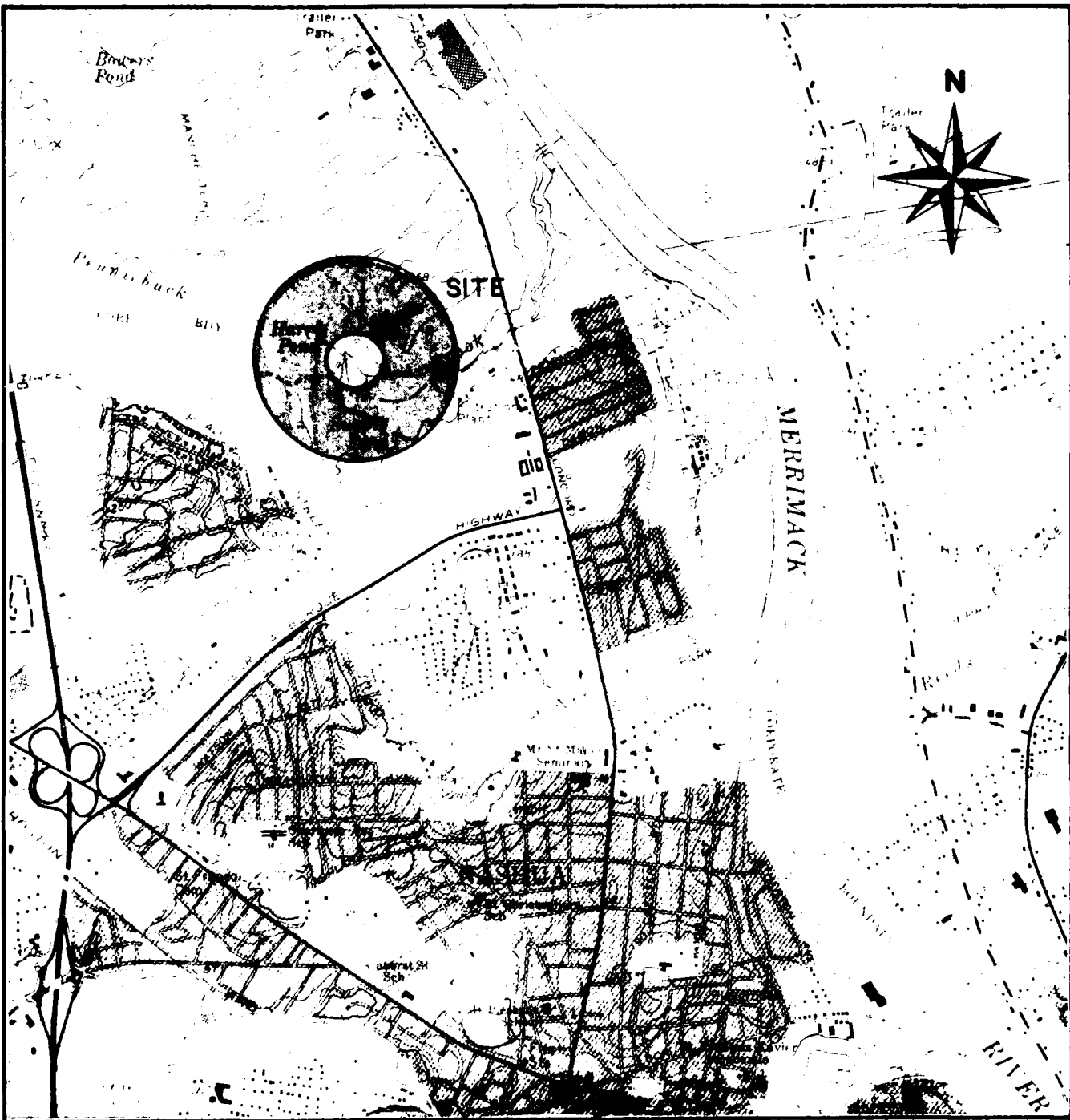

— SCALE —
 0 1000 2000 4000 FT.

FROM: USGS NASHUA NORTH, N.H.
 QUADRANGLE MAP

GOLDBERG, ZOINO, DUNNICLIFF & ASSOC., INC.
 GEOTECHNICAL CONSULTANTS
 NEWTON UPPER FALLS, MASS.

U.S. ARMY ENGINEER DIV NEW ENGLAND
 CORPS OF ENGINEERS
 WALTHAM, MASS.

NATIONAL PROGRAM OF INSPECTION OF NON-FED DAMS

LOCUS PLAN

FILE No. 2201

HARRIS POND DAM

NEW HAMPSHIRE

SCALE AS NOTED
 DATE OCTOBER 1978



Overview of dam from upstream left side

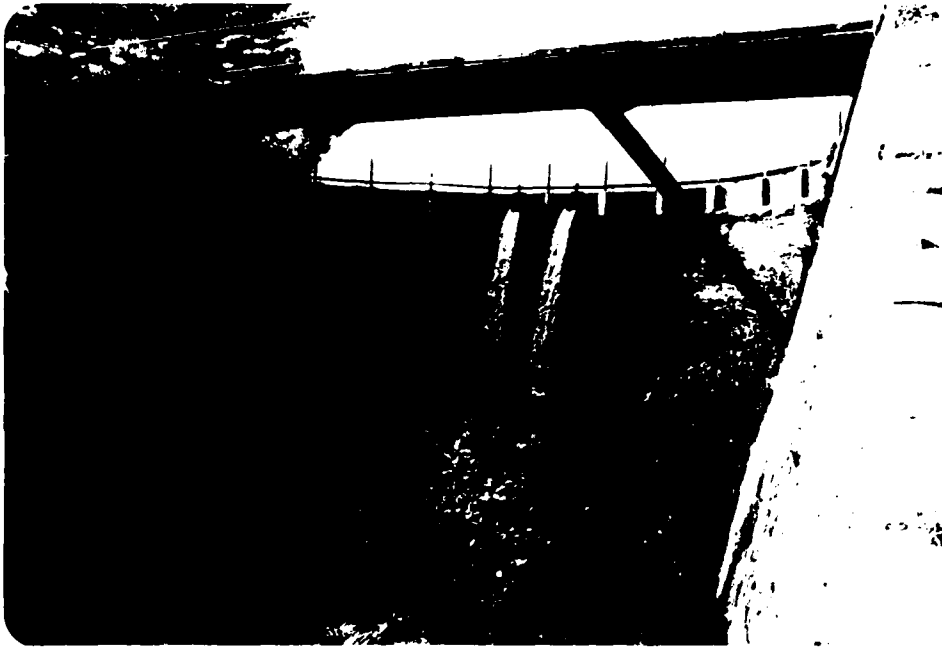

Overview of dam from downstream channel



Overview of top of dam from left abutment

(8) West Dike

The general condition of the west dike is good. No deficiencies in the vertical and horizontal alignment were noted. No seepage, sloughing, or erosion of the slopes was noted. However, heavy growth, including trees up to 24 inches in diameter, was noted on both the upstream and downstream slopes.

The west dike contains two outlet structures consisting of openings in "U" shaped end walls 2.5 feet wide and 2.5 feet deep with trash racks on their upstream faces. The right structure is equipped with a rectangular vertical lift gate with a non-rising stem and operating nut. The left structure has been sealed. Service personnel were not available to operate the gate. Field observations indicate that the functioning gate is a 12 inch pipe. Both gate outlets are submerged.

(9) Downstream Channel

The downstream channel quickly opens to Supply Pond the water level of which runs essentially up to Harris Pond Dam. The side slopes of the short section leading to Supply Pond are moderately steep but stable. There is considerable vegetation in the channel, and heavy growth on both sides of the channel overhangs the channel.

3.2 Evaluation

The Harris Pond Dam is rated in FAIR condition based upon the amount of seepage through the spillway and the seepage through the abutments. The gate houses were not available for inspection, and operation of the various gates could not be observed.

SECTION 4 - OPERATIONAL PROCEDURES

4.1 Procedures

As mentioned previously, the level of Harris Pond is kept as nearly constant as possible. Normally, this level is just a few inches below the top of the spillway. The pond level is controlled through regulation of the two 18 inch drain pipes in the spillway cap and the 72 inch penstock which is used to waste water. The water level of the pond is recorded visually every week day and on weekends during periods of high runoff.

4.2 Maintenance of Dam

No formal inspection or maintenance procedure is in effect for the dam. The dam is inspected frequently, though informally, by the Pennichuck Water Works personnel. Repairs to the dam and other maintenance is performed as necessary and when scheduling allows.

4.3 Maintenance of Operating Facilities

The two 18 inch pipes are operated twice a week to adjust flows to Supply Pond. The condition of the control gates and pipes is good. The 72 inch penstock is operated frequently although at random intervals, depending upon inflow to Harris Pond and water usage demands. Although the penstock and gate could not be observed or operated, the frequency of usage implies that the gate and penstock are maintained on a regular basis.

4.4 Description of Warning System

An automatic water level recording system is in effect at Harris Pond. The system is telemetered back to the water treatment plant near Supply Pond Dam. However, representatives of PWW do not use this system alone and prefer to visually record water levels daily during the week and as required on weekends (during periods of high runoff).

4.5 Evaluation

The dam's present FAIR condition is a result of the failure to perform the routine maintenance of pointing joints and arresting seepage through the dam. The day to day procedure of observing water levels and adjusting the levels, as necessary, is adequate but more attention needs to be paid to routine maintenance.

SECTION 5 - HYDRAULICS/HYDROLOGY

5.1 Evaluation of Features

(a) Design Data

Data sources available for Harris Pond Dam include prior inventories, inspection reports, and an Anderson-Nichols Company Flood Insurance Study performed in 1977. The New Hampshire Water Control Commission's "Data on Dams in New Hampshire" (April 10, 1939), the New Hampshire Water Resources Board's "Inventory of Dams and Water Power Developments" (August 25, 1936), and the Public Service Commission of New Hampshire's "Dam Record" (August 31, 1936) provide much of the basic data for the dam. Inspection reports from July 8, 1930; June 19, 1940; June 22, 1951; and October 25, 1973 are also available. The dam's owner, Pennichuck Water Works, provided 1895 plans and sections of the dam, a 1940 map of the watershed area, and piping diagrams for the pump stations near Supply Pond Dam downstream. The Flood Insurance Study (FIS) performed by Anderson-Nichols Company (ANCO) included a rating curve; a storage-elevation curve; 10, 50, 100 and 500-year peak inflows and outflows; and cross-section data at various points on Pennichuck Brook (including the dam).

(b) Experience Data

The only data on lake levels experienced in Harris Pond is for January, February, and March 1936. This data was gathered before the present concrete cap was added to the spillway, and therefore is not applicable to the current configuration. ANCO used data on outflow from Holt's Pond, which is just above Harris Pond, to determine the flow recurrence interval relations for Pennichuck Brook. This data is taken from a Drainage Master Plan Phase I; Town of Merrimack, N.H. by Hamilton Engineering Associates, Inc. in 1975.

(c) Visual Observations

Harris Pond Dam impounds one of two adjacent water supply reservoirs on Pennichuck Brook just north of Nashua, New Hampshire. The dam is an earthen embankment with a stone masonry core and arched spillway.

The spillway has a nearly vertical face about 31.6 feet high with an overall length of 85 feet, spanning a distance of 65 feet between the abutments of a roadway bridge on the dam crest. The spillway crest is at elevation 167.7 feet above Mean Sea Level (MSL). A wood plank walkway just above the spillway has supports that divide the spillway into eleven 7.5 foot long bays. At the time of the inspection the water level behind the dam was observed to be about 0.8 feet below the spillway crest. Two 18 inch diameter pipes built into the spillway crest with inverts at 165.0 feet MSL are used to control water flow into Supply Pond immediately downstream. The gates to these pipes were open and the pipes flowing freely.

The regulating outlets for the dam include a 72 inch diameter penstock that enters a gate house adjacent to the pump station at Supply Pond, and there splits into two 48 inch diameter pipes, one entering the pump station for water supply and power generation and one as a waste discharge into the stream channel below Supply Pond Dam. Supply Pond Dam is the subject of a separate Phase I Inspection Report in this series. Another outlet is a 60 inch diameter pipe that discharges into Supply Pond at the base of the dam. A third penstock (60 inch) originally serving a powerhouse just below the dam is now sealed and its gate inoperable.

On either side of the spillway the dam consists of an earthen embankment with a stone masonry core. The crest of the dam is about 5.7 feet higher than the spillway at an elevation of 173.4 feet MSL. A gate house on the left abutment houses the control mechanisms for the outlet penstocks.

A possible additional outlet at high stages in the lake is an earthen dike on the west bank of the pond. At this location a low point in a woods road embankment could possibly be overtopped at flood stages. The low point is at an elevation of about 172.0 feet or 5.1 feet above the water level observed. Two 12 inch diameter culverts provide a normal flow connection from Harris Pond to a smaller pond the the other side of the embankment. One of these has a gate mechanisms in the open position allowing some flow to pass, while the other appeared to be inoperable and closed.

Supply Pond is located immediately downstream of Harris Pond Dam. Below Supply Pond Dam the Pennichuck Brook channel has high banks and is relatively steeply sloping. A newly constructed water supply conduit bridge located about 225 feet downstream of the dam has a top elevation of 125 feet and two 60 inch diameter culverts. About 1100 feet further downstream the stream passes under New Hampshire Route 3 via a 15 foot by 15 foot box culvert. Beyond this point the stream channel widens considerably for the remaining mile or so to its confluence with the Merrimack River.

(d) Overtopping Potential

The hydrologic conditions of interest in this Phase I investigation are those required to assess the dam's overtopping potential and its ability to safely allow an appropriately large flood to pass. This requires using the discharge and storage characteristics of the structure to evaluate the impact of an appropriately-sized Test Flood (TF). None of the original hydraulic and hydrologic design records are available for use in this study.

Guidelines for establishing a recommended Test Flood based on the size and hazard classifications of a dam are specified in the "Recommended Guidelines" of the Corps of Engineers. The impoundment of 1670 acre-feet and height of 35 feet is in the 1000 to 50,000 acre-foot storage range and less than 40 foot height for an INTERMEDIATE sized structure.

The previous ANCO FIS study provided 10, 50, 100, and 500-year inflows to Harris Pond. This FIS work by ANCO produced flow rates per square mile of drainage area that are low by comparison with typical rates for the region. The 100-year inflow of 630 cfs is equal to about 25.5 csm. The reason for these low flows is the character of the basin upstream of Harris Pond Dam. The drainage basin is swampy, with two large ponds (Bower's and Holt's) upstream.

However, it is apparent from ANCO's work that the primary control causing this low flow is the culvert across Pennichuck Brook under Route 101A. The culvert controls 19 sq. miles of the drainage area and drastically reduces peak flows.

For the purpose of this Test Flood Analysis, it does not seem proper to allow a man-made construction such as the Route 101-A culvert, which might be enlarged or removed at any time, to determine test flood inflows. Therefore, ANCO's FIS flow values would not apply to this study.

The "Recommended Guidelines" suggest that if a range of values is indicated for the Test Flood, the magnitude should be related to the hazard potential. Since the hazard is on the low side of the SIGNIFICANT category, the test inflow to Harris Pond is taken to be the one-half PMF. The COE's "Maximum Probable Flood Peak Flow Rates" gives a 1/2 PMF of 300 csm for a flat drainage area of 25 sq. miles. Because of the exceptional amount of storage, in swamps and ponds, upstream of Harris Pond, we will use 200 csm, yielding a peak inflow of 4940 cfs.

A test inflow based on 200 cfs of 4940 cfs, is routed through Harris Pond using the Stage Discharge curve and Storage-Elevation curve shown in Appendix D. The Stage-Discharge curve provided sums discharges over the spillway, through the waste pipes, over the dam crest, and through or over the west dike. It is assumed that the waste pipes are fully open. The calculations determining this curve are documented in Appendix D.

The outflow after attenuation by storage in Harris Pond is 4800 cfs, with the peak water surface at elevation 173.1 ft. MSL (5.4 feet above the spillway crest, .3 feet below the top of dam).

5.2 Hydrologic/Hydraulic Evaluation

The outlet capacity of this dam is sufficient to pass the recommended Test Flood. The dam could pass about 5200 cfs without overtopping if the waste pipes are open.

5.3 Downstream Dam Failure Hazard Estimate

The peak outflow at Harris Pond Dam that would result from dam failure is estimated using the procedure suggested in the Corps of Engineers New England Division's April 1978 "Rule of Thumb Guidelines for Estimating Downstream Dam Failure Hydrographs," as clarified in a December 7, 1978 meeting. Failure is assumed to occur as soon as the dam crest is overtopped, at an elevation of 173.4 feet. This

is 5.7 feet above the spillway and about 35 feet above the backwater from Supply Pond. It is assumed that a 40 foot gap is opened in the dam. The peak failure outflow through this gap, over the spillway, and through waste pipes would be about 15,200 cfs.

The attenuation of this flow caused by Supply Pond is estimated using procedures suggested by the "Rule of Thumb Guidelines." The calculations shown in Appendix D give a peak flow from Supply Pond of 13,500 cfs and an elevation of 145.9 feet at Supply Pond Dam, which is 9.1 feet above the spillway and 5.0 feet above the dam crest.

Two scenarios are investigated below Supply Pond Dam. The first scenario assumes that Supply Pond Dam remains intact and peak outflow is 14,200 cfs (13,500 cfs over the dam plus 700 cfs from the 72 inch pipe from Harris Dam which reenters Pennichuck Brook below Supply Pond Dam). The other assumes that Supply Pond Dam fails, increasing the flow at Supply Pond Dam from 13,500 cfs to 27,800 cfs.

In either scenario, the dam failure flood wave would probably cause significant damage to the pump stations and conduit crossings immediately downstream of Supply Pond Dam. The conduits involved carry a portion of the water supply for the Town of Nashua. Since these structures are usually unoccupied, the potential for loss of life at this site would be low.

The only major structure along the channel between Supply Pond Dam and the Highway 3 bridge is a Pennichuck Water Works Water Treatment Plant presently under construction. The lowest part of this plant will be 29 feet above the stream bed. Since the flood wave downstream of the dam would not be expected to exceed more than two-thirds of the original height at Supply Pond Dam of about 35 feet, whether or not Supply Pond Dam remains intact, the Water Treatment Plant should not be affected.

Because of the comparatively steep slope and narrow channel downstream of Supply Pond Dam, there would be little attenuation of flow between the dam and the highway bridge, some 1100 feet downstream. Therefore, it is assumed that the peak flow at the bridge would be the same as that at Supply Pond Dam.

The Highway 3 bridge consists of a 15 foot by 15 foot conduit with an invert 31 feet below the roadway. Using a nomograph in FHWA Hydraulic Engineering Circular No. 5 for the conduit, and a simple weir equation for the roadway, the elevation necessary to pass the inflow for either scenario can be estimated. The estimated flow of 14,200 cfs if Supply Pond Dam were to hold would require a water surface 2.4 feet above the road surface. The estimated flow of 27,800 cfs if Supply Pond were to fail would require a water surface 7.2 feet above the road. Either of these situations could result in significant structural damage to the bridge. Also, because of the rapid rate of rise to be expected, there would be some hazard to the occupants of any vehicles that happened to be passing this location on this heavily travelled highway.

Below the Highway 3 bridge, Pennichuck Brook widens before feeding into the Merrimack River. It is probable that the flood would quickly attenuate downstream of the bridge.

SECTION 6 - STRUCTURAL STABILITY

6.1 Evaluation of Structural Stability

(a) Visual Observations

With the exception of seepage through the right embankment, open joints on the downstream face of the spillway, and the joint between the concrete spillway cap and the stone masonry, field investigation revealed no significant displacements or distress which warrant the preparation of structural stability calculations based on assumed sectional properties and engineering factors.

(b) Design and Construction Data

No plans or calculations of value to a stability assessment are available for this dam.

(c) Operating Records

There are no formal operating records for the dam that would be of value in evaluating the stability of the dam under high flows. Water level readings in 1936 during the large flood of that year are available, however, the dam did not have the concrete spillway cap at that time which has changed the structure of the dam making those records less meaningful.

(d) Post Construction Changes

The numerous alterations conducted during the lifetime of this dam have not decreased the structural stability of this dam.

(e) Seismic Stability

This dam is located in Seismic Zone 2 and, in accordance with recommended Phase I guidelines, does not warrant seismic analyses.

SECTION 7 - ASSESSMENT, RECOMMENDATIONS
AND REMEDIAL MEASURES

7.1 Dam Assessment

(a) Condition

The Harris Pond Dam is in FAIR condition at the present time.

(b) Adequacy of Information

The lack of in-depth engineering data does not permit a definitive review. Therefore, the adequacy of the dam cannot be assessed from the standpoint of reviewing design and construction data. This assessment is thus based primarily on the visual inspection, past performance, and sound engineering judgment.

(c) Urgency

The engineering studies and improvements described herein should be implemented by the owner within one year of receipt of this Phase I Inspection Report.

(d) Need for Additional Investigations

Additional investigations are required as recommended in Paragraph 7.2.

7.2 Recommendations

It is recommended that the seepage emanating from the toe of the right embankment and right downstream training wall should be investigated by a qualified geotechnical engineer. Based on this investigation an appropriate design to protect the toe from erosion should be instituted.

7.3 Remedial Measures

The Harris Pond Dam requires the following operating and maintenance improvements:

- (1) Point open joints of downstream spillway face with a high strength mortar and arrest seepage between the base of the concrete cap and the top of the slant masonry.

- (2) Point open joints of the right abutment and downstream training wall with high strength mortar. Reconstruct the splayed end of this training wall.
- (3) Point open joints of left abutment with high strength mortar.
- (4) Clear both embankments of all brush and trees and institute a regular program of slope maintenance.
- (5) Trim and remove all trees and vegetation from the downstream channel which might become a serious obstruction in the event of a serious storm. Institute a regular program of removing debris from in and around channel areas.
- (6) Institute a program of annual technical inspections of the dam and appurtenances.
- (7) Clear both embankments of the west dike of all brush and trees and institute a regular program of slope maintenance.
- (8) Develop a formal warning system to alert people downstream in the event of an emergency.

7.4 Alternatives

There are no meaningful alternatives to accomplish the above listed actions.

APPENDIX A
VISUAL INSPECTION CHECKLIST

INSPECTION TEAM ORGANIZATION

Date: October 31, 1978

NH 00122
HARRIS POND DAM
Nashua, New Hampshire
Pennichuck Brook
NHWRB 165.05

Weather: Clear, 55°F

INSPECTION TEAM

Nicholas Campagna	Goldberg, Zoino, Dunicliff & Associates, Inc. (GZD)	Team Captain
William S. Zoino	GZD	Soils & Foundation
Robert Minutoli	GZD	Soils
Andrew Christo	Andrew Christo Engineers (ACE)	Structural
Paul Razgha	ACE	Structural
Richard Laramie	Resource Analysis, Inc.	Hydrology

Mr. Pattu Kesavan of the New Hampshire Water Resources Board accompanied the inspection team.

CHECK LISTS FOR VISUAL INSPECTION		
AREA EVALUATED	BY	CONDITION & REMARKS
DAM EMBANKMENT		
Vertical alignment and movement	NAC	No deficiencies noted
Horizontal alignment and movement		No deficiencies noted
Condition at abutments		No deficiencies noted
Trespassing on slopes		No evidence
Sloughing or erosion of slopes		None noted
Rock slope protection		None
Unusual movement or cracking at or near toe		None noted
Unusual downstream seepage		None at toe of left embankment; 5 to 10 gpm at toe of right embankment (50 ft. right of right training wall and 100 ft. downstream of centerline); water clear and clean
Pipes or boils		None noted
Maintenance of slopes	NAC	Considerable heavy brush and trees up to 18 inch diameter on both upstream and downstream slopes on both left and right embankments

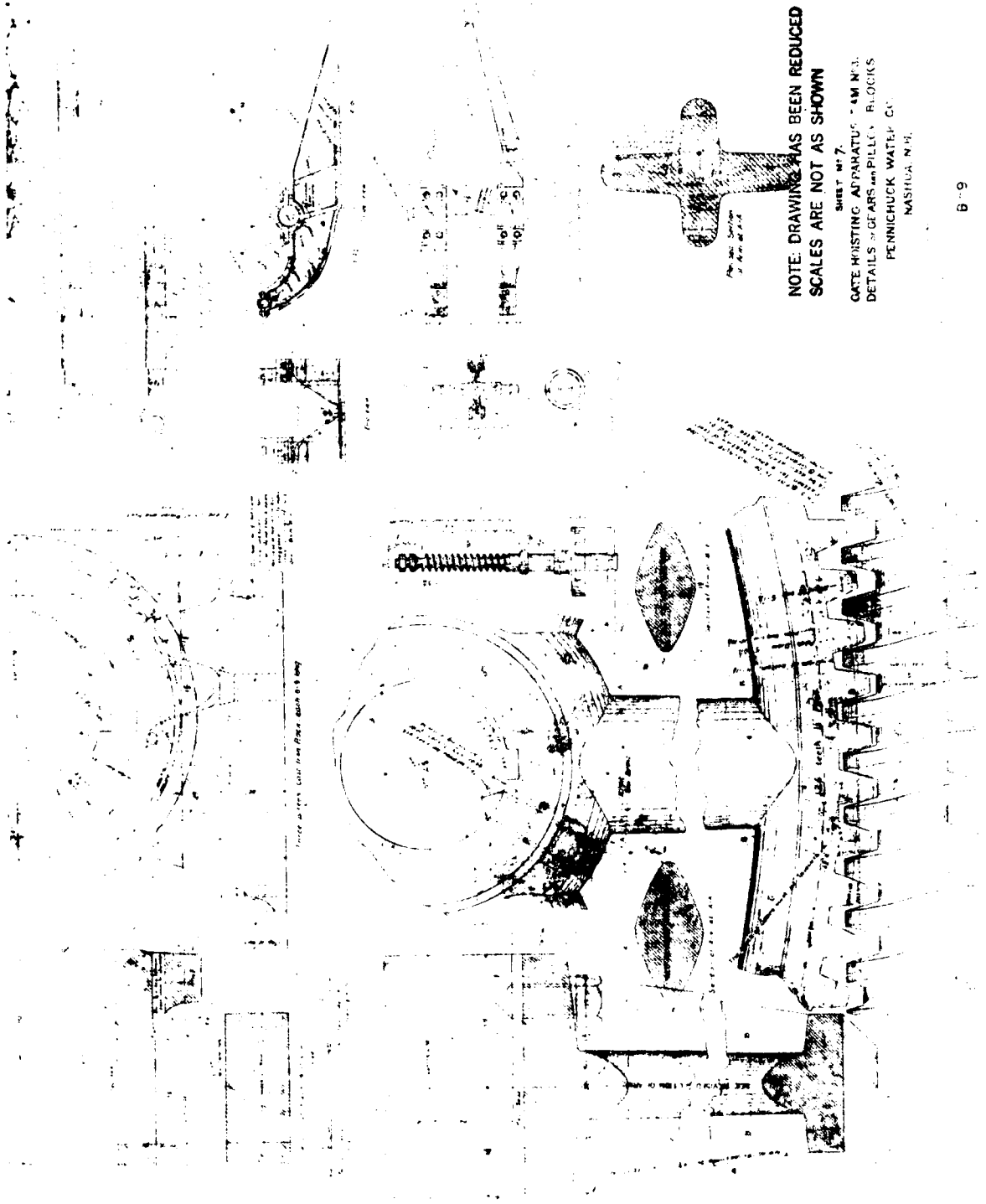

NOTE: DRAWING HAS BEEN REDUCED
SCALES ARE NOT AS SHOWN

SHEET NO. 7
GATE HOISTING APPARATUS - AM. N. S.
DETAILS OF GEARS AND PULLEY BLOCKS
PENNICKUCK WATER CO.
NASHUA, N. H.

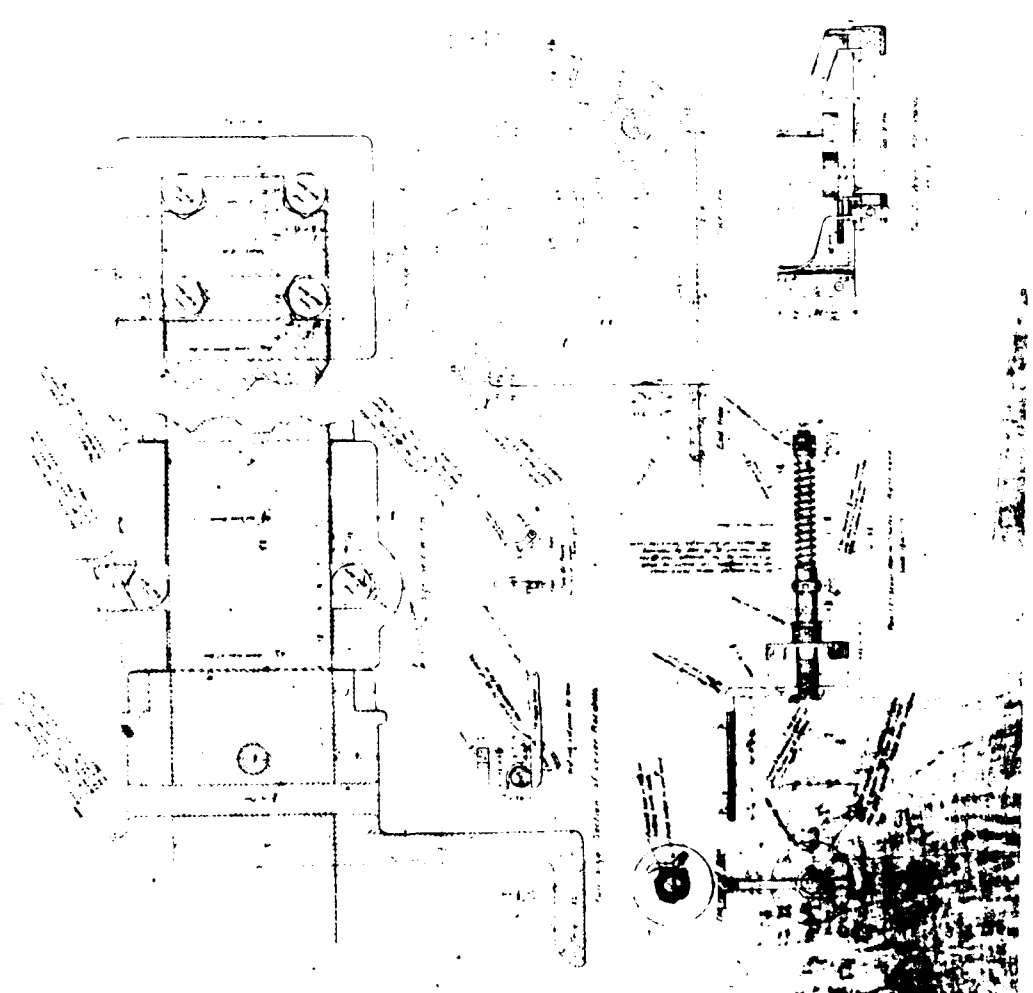

NOTE: DRAWING HAS BEEN REDUCED
 SCALES ARE NOT AS SHOWN

SHEET NO. 8.
 DETAILS OF GATE HOISTING APPARATUS, DAM NO. 3.
 FERRISBURGH WATER CO.
 MASHUA, N. H.

DESIGNED BY JAMES F. FERRIS, CIVIL ENGINEER
 REGISTERED PROFESSIONAL ENGINEER
 STATE OF NEW HAMPSHIRE

John R. Ferris
 June 8, 1908

B-10

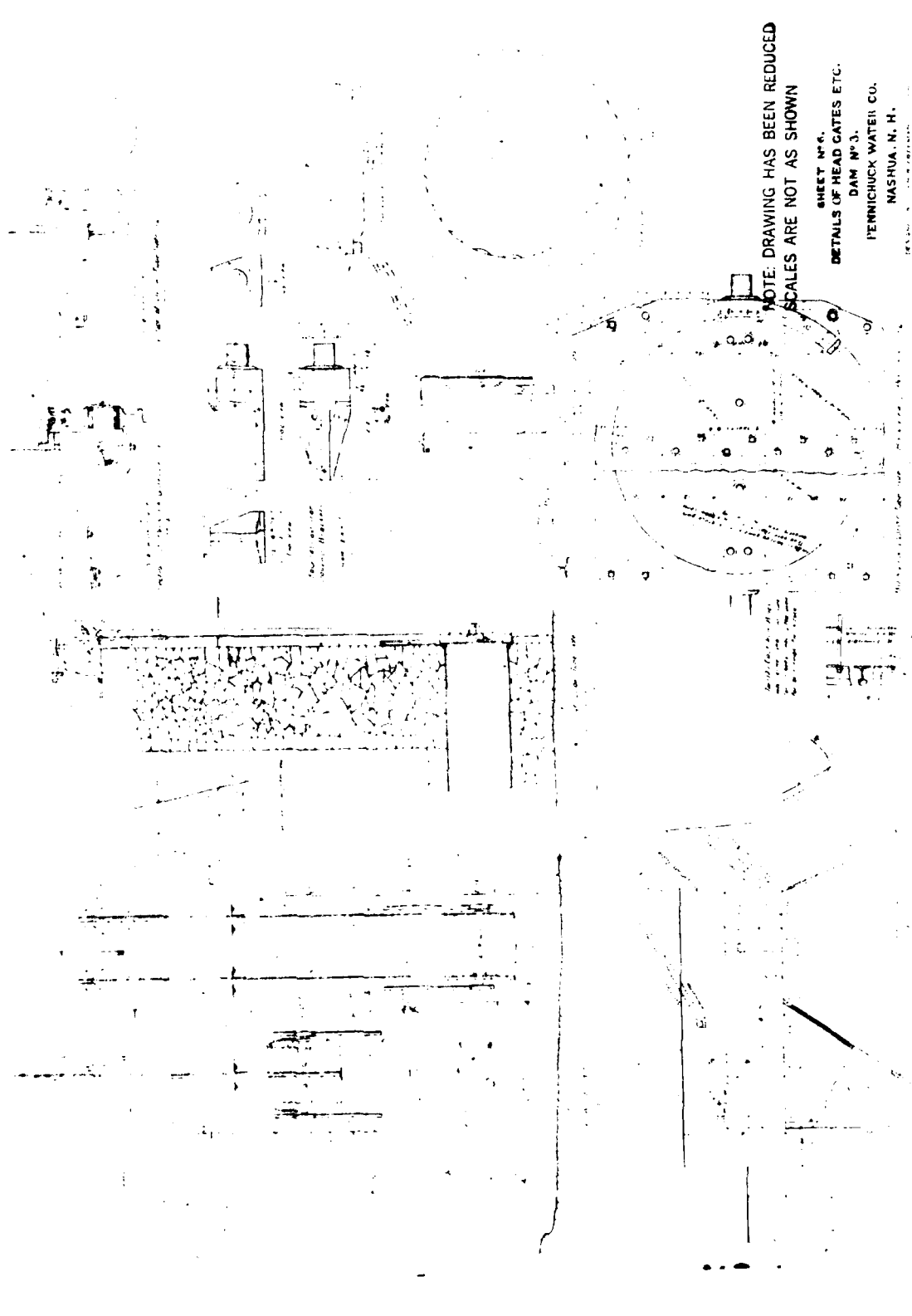

NOTE: DRAWING HAS BEEN REDUCED
SCALES ARE NOT AS SHOWN

SHEET N° 6.
DETAILS OF HEAD GATES ETC.
DAM N° 3.
PENNICK WATER CO.
NASHUA, N. H.

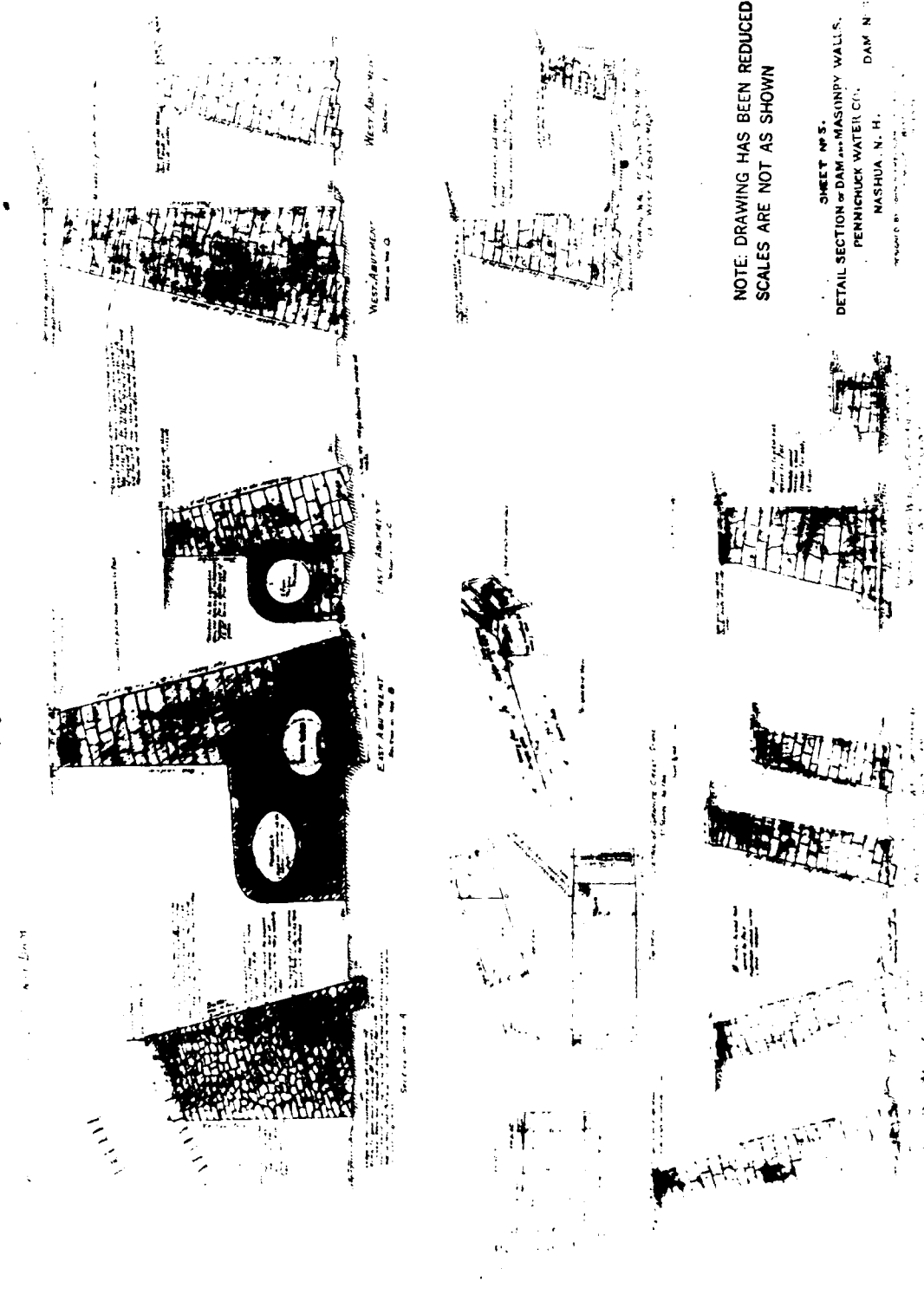

NOTE: DRAWING HAS BEEN REDUCED
SCALES ARE NOT AS SHOWN

SHEET NO. 5.
DETAIL SECTION OF DAM AND MASONRY WALLS.
PENNICK WATER CO. DAM NO. 1
NASHUA, N. H.

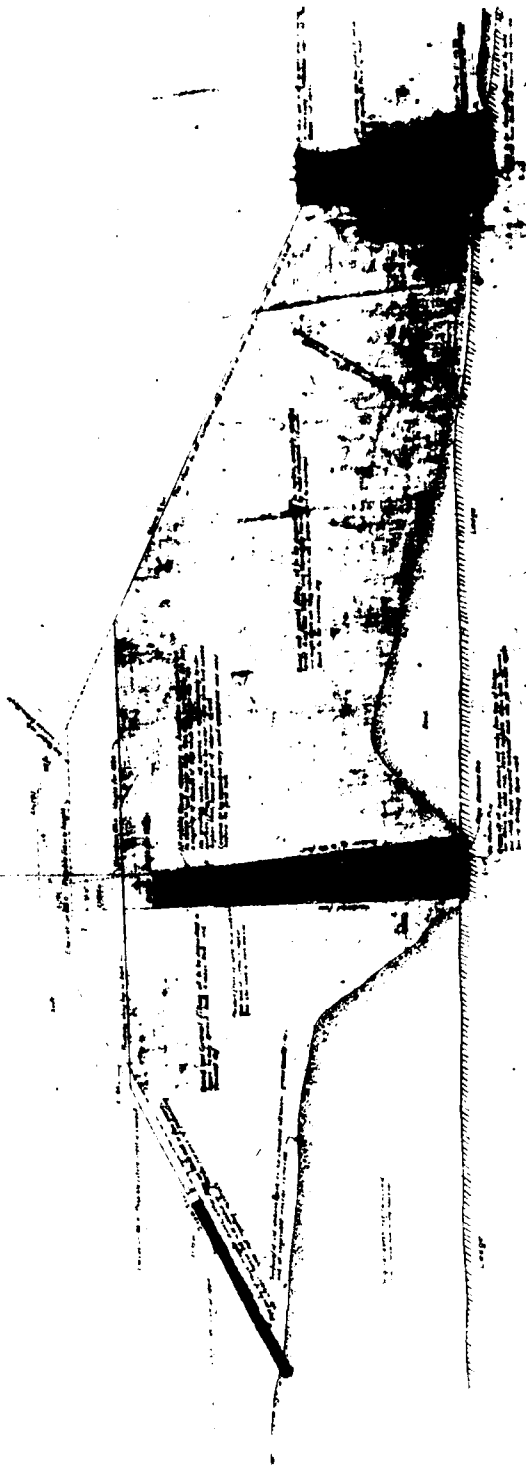

NOTE: DRAWING HAS BEEN REDUCED
SIZES ARE NOT AS SHOWN



NOTE: DRAWING HAS BEEN REDUCED
SCALES ARE NOT AS SHOWN

SHEET NO.
OUTLINE PLAN FOR DE S. N.Y.
FENNICHUCK MAT-B.U.I.
NASHUA N.H.

B-4

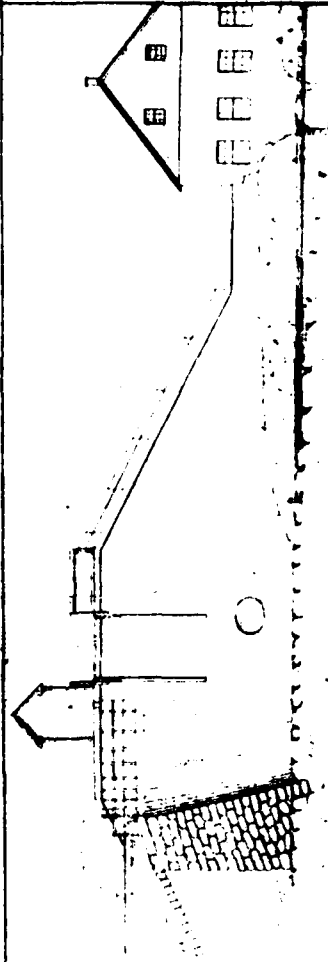

Section through Center of Spillway

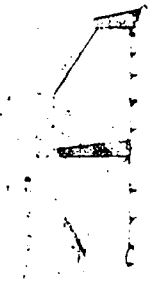

Section through

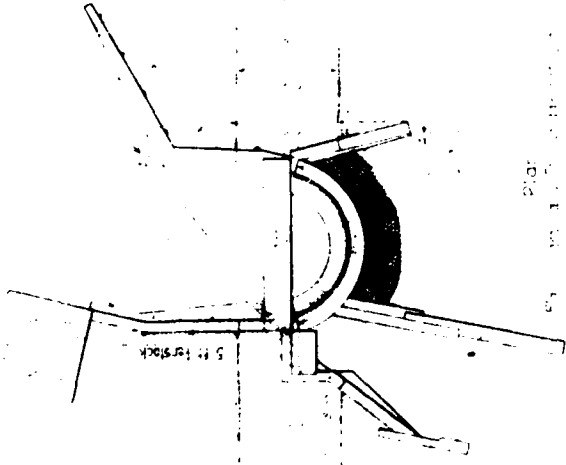

Plan

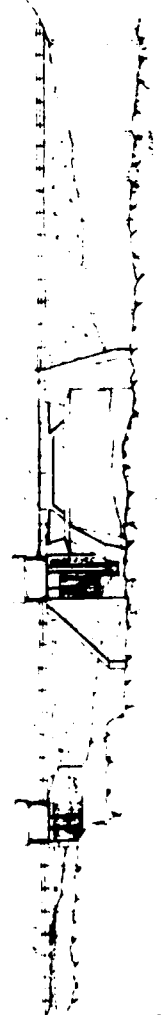

Elevation

NOTE: DRAWING HAS BEEN REDUCED
 SCALES ARE NOT AS SHOWN

HARRIS DAM

DAM No. 3,
 BUREAU OF RECLAMATION DESIGN BY
 U.S. GEOLOGICAL SURVEY

DATE: 1911

NO. 100

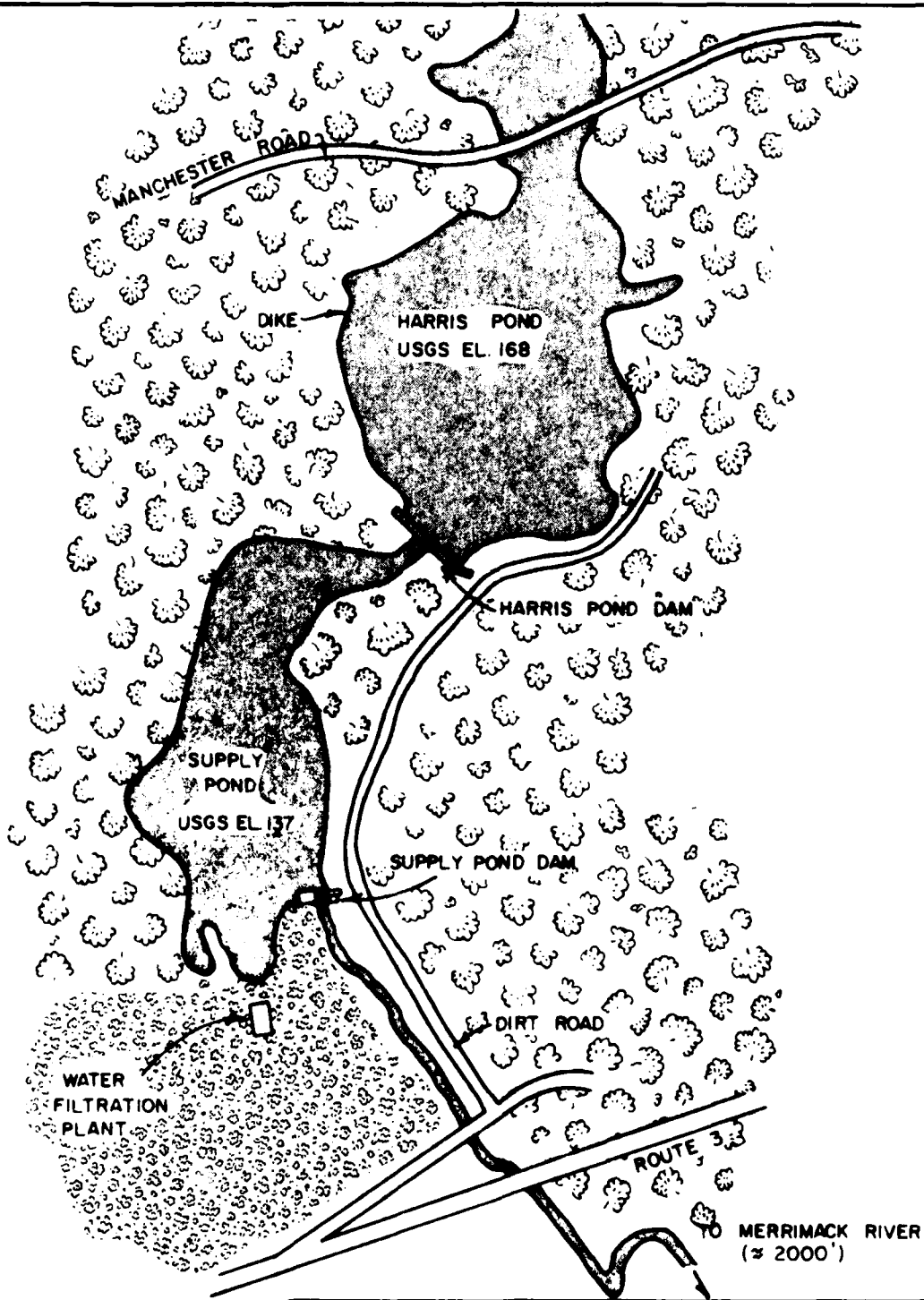

GOLDBERG, ZOINO, DUNNICLIFF & ASSOC., INC.
 GEOTECHNICAL CONSULTANTS
 NEWTON UPPER FALLS, MASS.

U.S. ARMY ENGINEER DIV. NEW ENGLAND
 CORPS OF ENGINEERS
 WALTHAM, MASS.

NATIONAL PROGRAM OF INSPECTION OF NON-FED. DAMS

SITE PLAN

FILE No. 2201

HARRIS POND DAM

NEW HAMPSHIRE

SCALE 1" = 600'

DATE OCTOBER 1978

APPENDIX B

		<u>Page</u>
FIGURE 1	Site Plan	B-2
	Construction Drawing of 1895 Design showing Plan and Elevation of Dam	B-3
	Design Drawing of Plan of Dam (1893)	B-4
	Plan and Section of West Dike 1893)	B-5
	Section of Dam (1893)	B-6
	Detail Section of Dam (1893)	B-7
	Details of Gates (1893)	B-8
	Details of Gear and Pillow Blocks for Gates (1893)	B-9
	Details of Gate Hoisting Apparatus (1893)	B-10
	Details of Penstock and Drain Tube (1893)	B-11
	Plan and Elevation of Dam (1893)	B-12
	List of Pertinent Records not included and their Location	B-13

CHECK LISTS FOR VISUAL INSPECTION		
AREA EVALUATED	BY	CONDITION & REMARKS
B. Rock slides or falls	RM	None noted
C. Control of debris		Considerable vegetation and saplings growing in channel
D. Trees overhanging channel		Heavy growth on both sides which does extend over channel
E. Other obstructions	RM	None noted
OPERATION AND MAINTENANCE FEATURES		
A. Reservoir Regulation Plan	NAC	
Normal procedure		Maintain pond level 2.5 ft. above old masonry spillway. Level controlled by 72 inch penstock and two 18 inch pipes in spillway.
Emergency procedure		Five foot diameter drain could be opened by personnel at near-by downstream treatment plant
Compliance with designated plans		Satisfactory
B. Maintenance	NAC	
Quality		Minor maintenance required
Adequacy		Dam observed daily except Saturday and Sunday by treatment plant personnel

CHECK LISTS FOR VISUAL INSPECTION

AREA EVALUATED	BY	CONDITION & REMARKS
Penstock gate	AC	Not operated due to lack of access. Owners representative indicated gate is in servicable condition.
Stone masonry training walls		Good
Trash rack	AC	Good
WEST DIKE		
Vertical alignment and movement	RM	No deficiencies noted
Horizontal alignment and movement		No deficiencies noted
Sloughing or erosion of slopes		None noted
Unusual downstream seepage		None noted
Unusual movement or cracking at or near toe		None noted
Piping or boils		None noted
Maintenance of slopes		Mature trees up to 24 inch diameter on slopes
Outlet structure concrete and trash rack		Good
Outlet conduits and sluice gate		Submerged; one conduit sealed
DOWNSTREAM CHANNEL		
A. Slope Conditions	RM	Moderately steep but stable

CHECK LISTS FOR VISUAL INSPECTION

AREA EVALUATED	BY	CONDITION & REMARKS
Rusting or staining on concrete	AC	None
Visible reinforcing		None
Efflorescence		None
Seepage		Seepage through joint between concrete cap and top of stone masonry. Minor seepage through open joints of cemented stone masonry; 50% of joints void of mortar
D. Dual Waste Gates		
Operating mechanism		Good
Catwalk		Good, adequately secured with chain link gates
P.V.C. aeration pipe		Broken, no longer functions
E. Gate House		
Structure		Good
Waste gate		Not operated due to lack of access. Owner's representative indicated gate is in servicable condition
Telemetering System		Not observed due to lack of access. Owner's representative indicated this equipment is in good servicable condition
Penstock		Abandoned-outlet gate sealed
F. Auxiliary Gate House		
Structure	AC	Good

CHECK LISTS FOR VISUAL INSPECTION

AREA EVALUATED	BY	CONDITION & REMARKS
OUTLET WORKS		
A. Approach Channel Shoreline Bottom conditions Rock slides or falls Log boom Control of debris Trees overhanging channel	RM RM	Moderately sloping and stable Not visible No rock in vicinity None No debris evident Many trees along shoreline immediately upstream of dam
B. Spillway Abutments Seepage Masonry joints Cracking Efflorescence	AC 	Evidence of seepage through right downstream training wall; 5 to 10 gpm through right downstream end splayed wall Abutments and training walls 50% void of mortar Random cracking in mortar facing at abutment Considerable efflorescence at mortar joints in right downstream training wall
C. Spillway Condition of concrete Spalling Cracking	 AC	Good None None

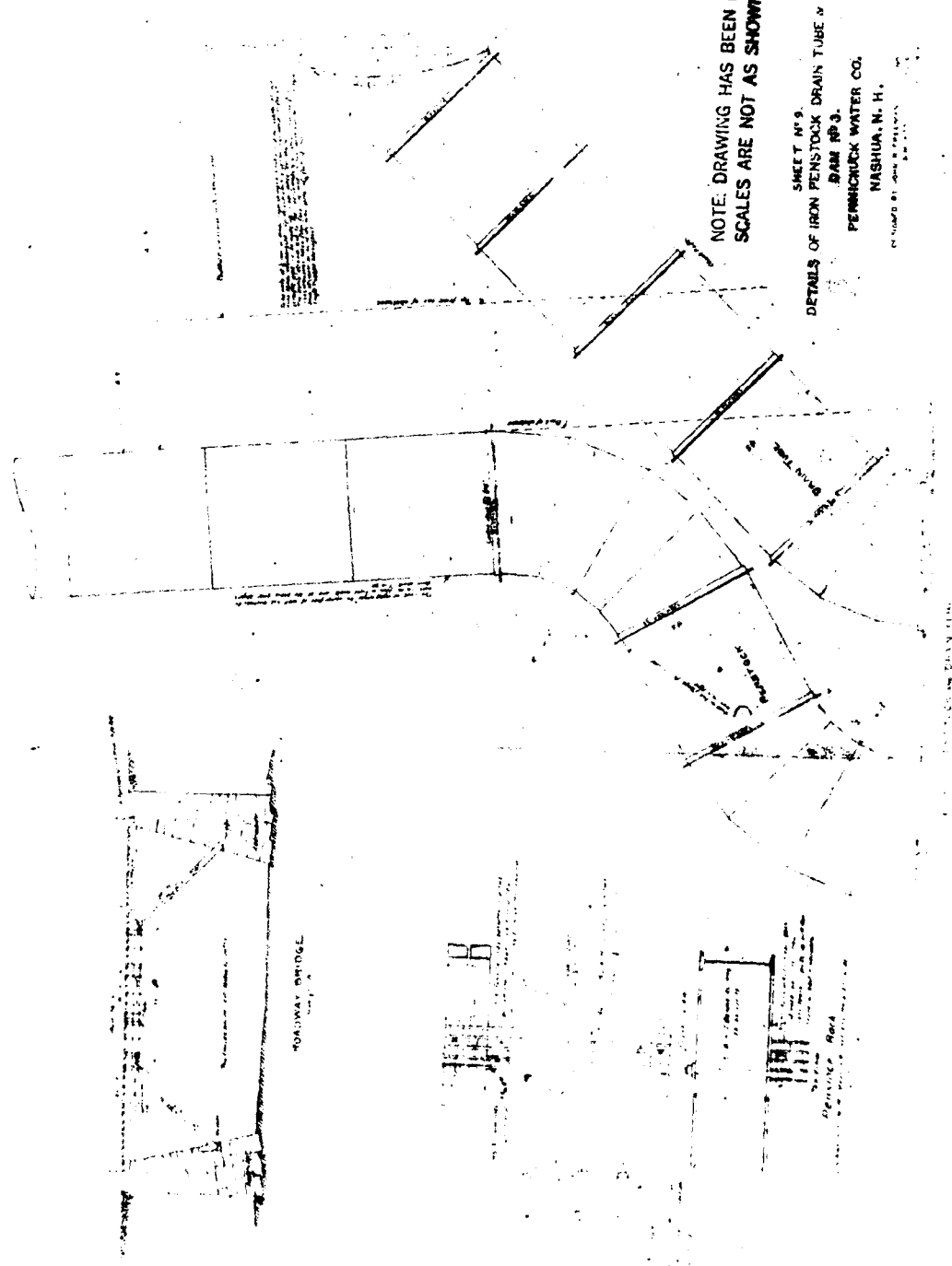

NOTE: DRAWING HAS BEEN REDUCED
 SCALES ARE NOT AS SHOWN

SHEET NO. 9
 DETAILS OF IRON PENSTOCK DRAIN TUBE
 DAM NO. 3.
 PENNICK WATER CO.
 NASHUA, N. H.

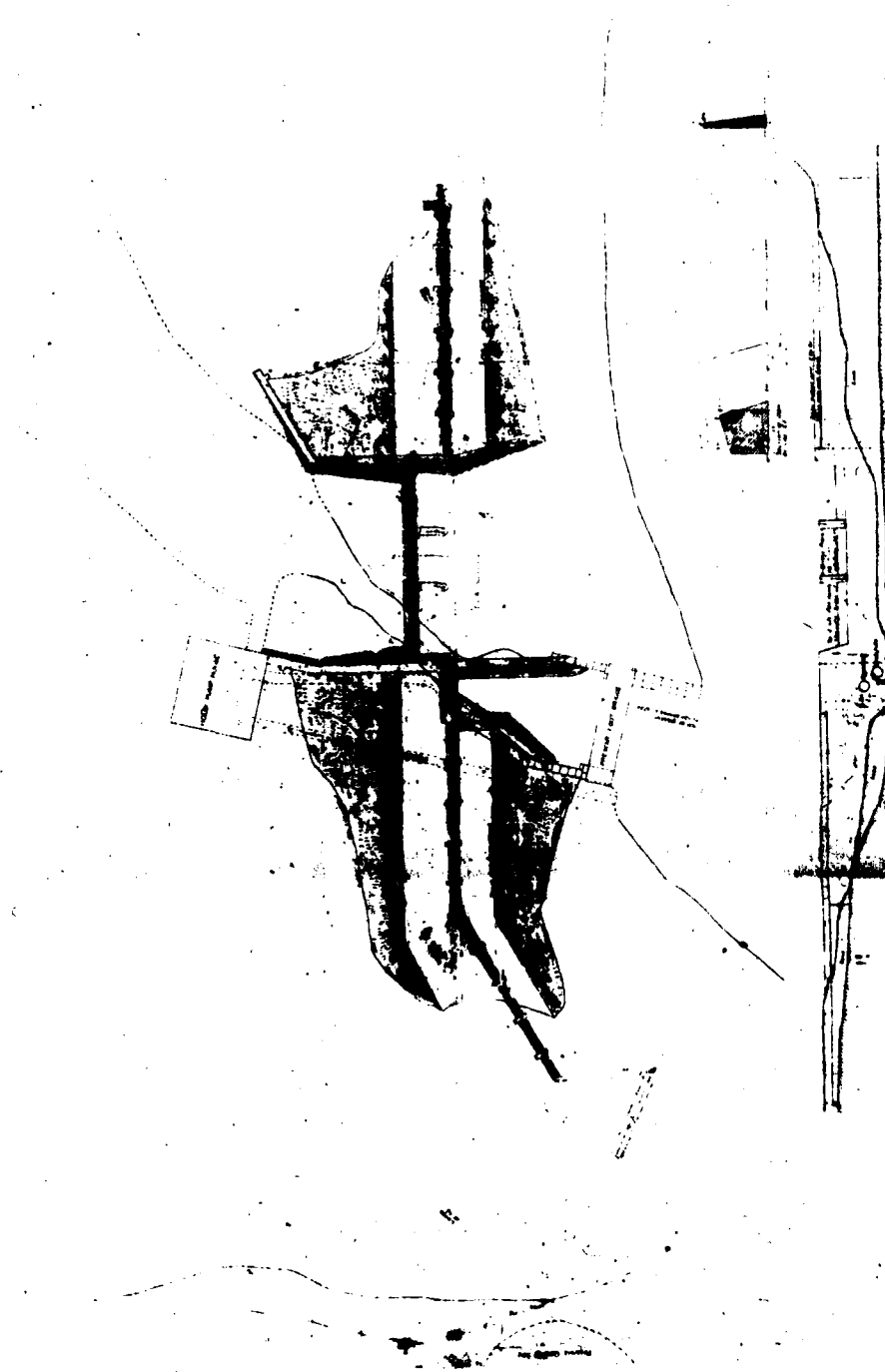

NOTE: DRAWING HAS BEEN REDUCED
 SCALES ARE NOT AS SHOWN
 OUTLINE PLAN FOR DAM
 PENNICKOCK WATER CO.
 NASHUA, N.H.

SECTION FROM CENTER OF DAM
 SEE PROVISIONS IN CONTRACT FOR
 TO REPLACE EXISTING DAM AND ABOUT 20 YEARS AND
 AND WOULD BE AT A DEPTH OF 10 FEET BELOW EXISTING LEVELS
 SCALE 1/4" = 1'-0"

The New Hampshire Water Resources Board, 37 Pleasant Street, Concord, N.H. 03301 maintains a correspondence file on the dam dating back to the 1930's. Included in this file are:

- (a) Inspection reports of the dams from inspections made in October 1973, June 1951, June 1940, April 1939, August 1936, and July 1930.
- (b) Gage readings of the levels of Harris Pond in January, February and March of 1936.

The Pennichuck Water Works (PWW) maintains permanent records of the daily water level readings taken at this dam. The PWW has offices at 11 High Street, Nashua, N.H. 03060.

APPENDIX C
SELECTED PHOTOGRAPHS

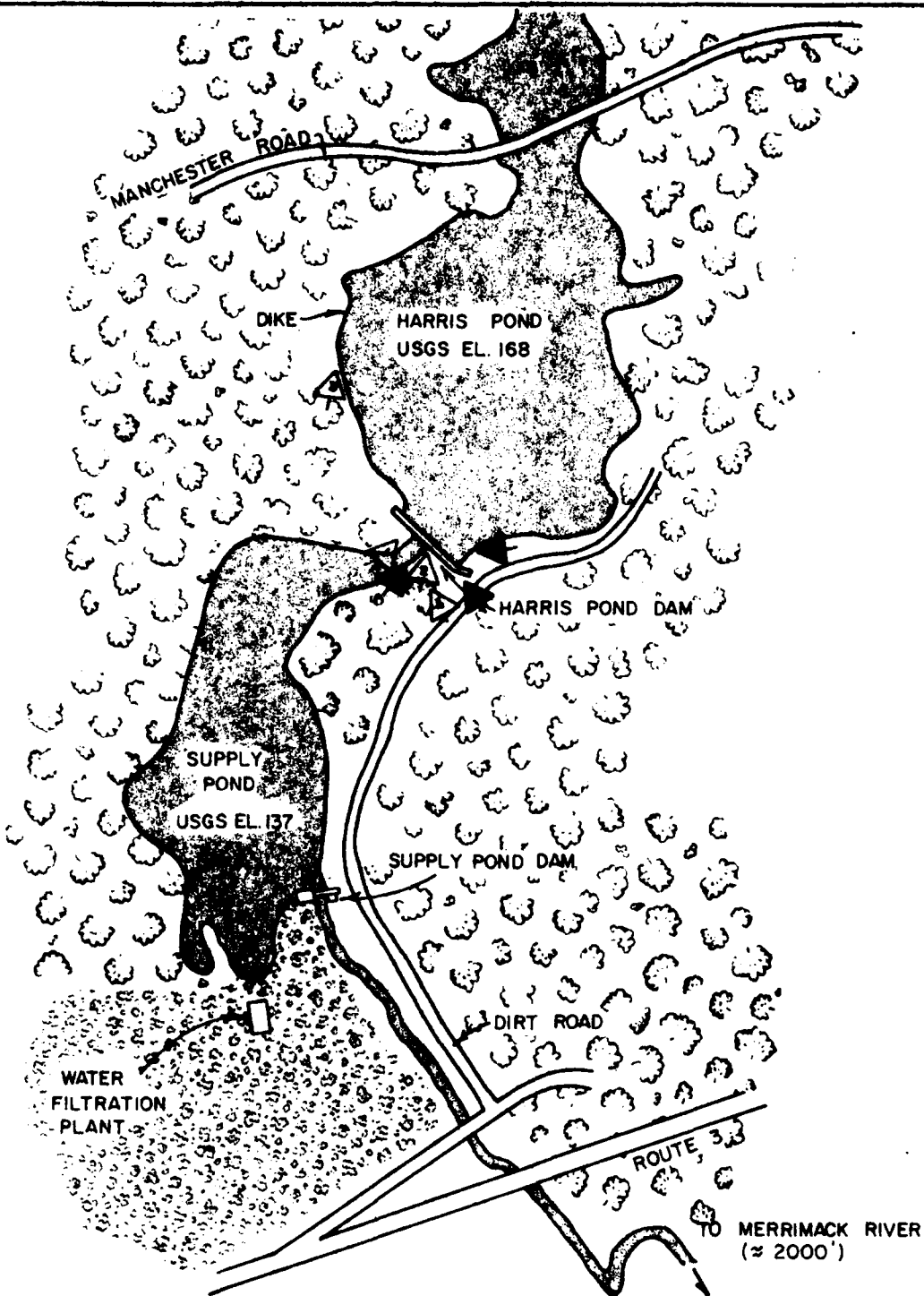

➤ OVERVIEW

▷ APPENDIX C

GOLDBERG, ZONHO, DUNNCLIFF & ASSOC., INC.
 GEOTECHNICAL CONSULTANTS
 NEWTON UPPER FALLS, MASS.

U.S. ARMY ENGINEER DIV NEW ENGLAND
 CORPS OF ENGINEERS
 WALTHAM, MASS.

NATIONAL PROGRAM OF INSPECTION OF NON-FED. DAMS

LOCATION AND ORIENTATION OF PHOTOS

FILE NO. 2201

HARRIS POND DAM

NEW HAMPSHIRE

SCALE 1" = 600'

DATE OCTOBER 1978

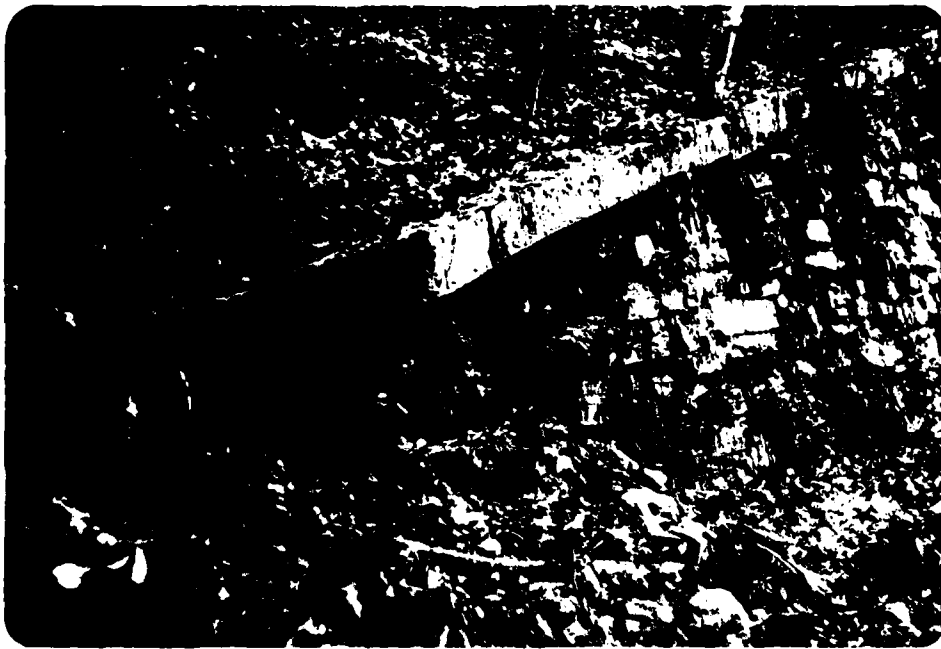

1. View of seepage at base of right downstream training wall



2. View from left downstream training wall of leakage between top of original dam and newer concrete spillway



3. View of dike on right side of reservoir to fill in natural low area

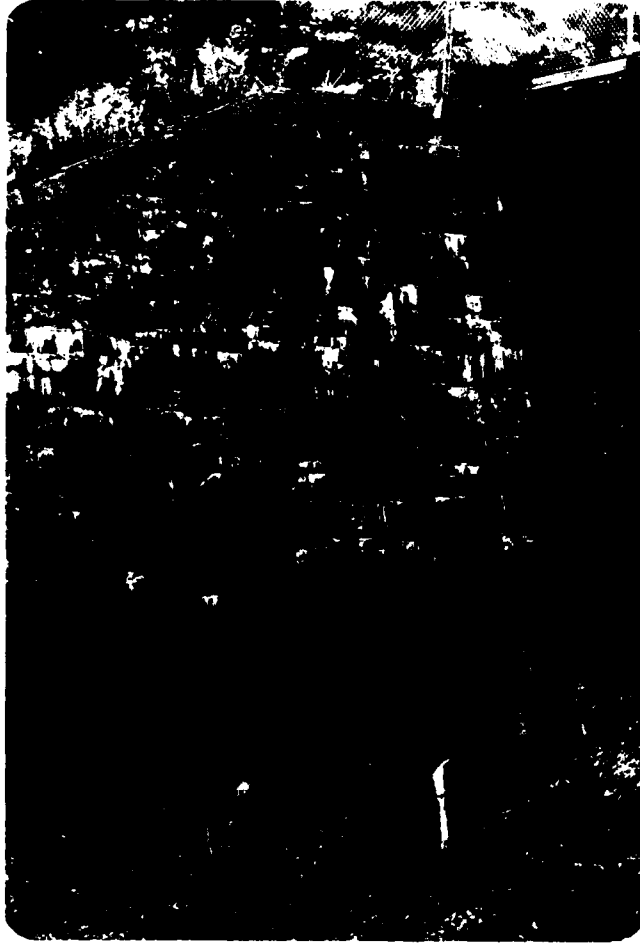



4. View of right abutment from downstream channel showing cracks in concrete facing at base of wall

APPENDIX D
HYDROLOGIC/HYDRAULIC COMPUTATIONS

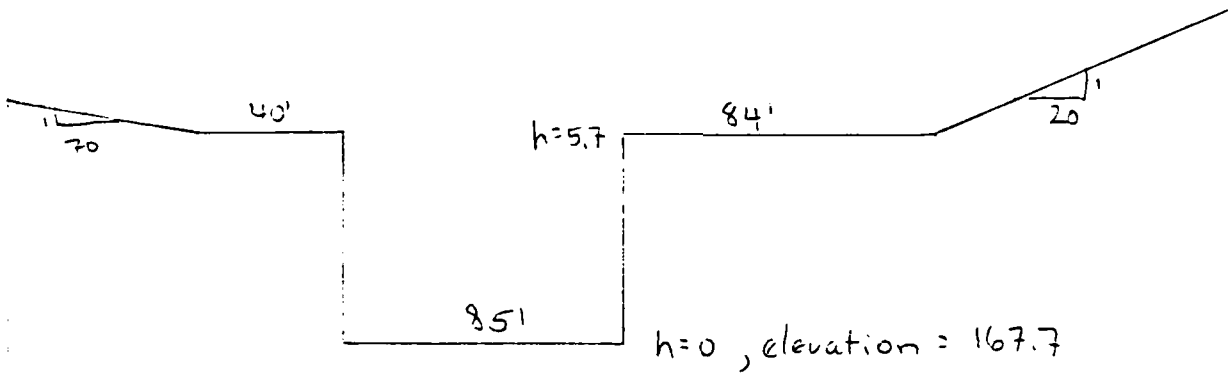
The information used to determine the cross section at Harris Pond Dam was determined from field notes and 1977 Anderson-Nichols Company (Anco) survey data from FIS work.





2-18" inverts at h = -2.7

 72" pipe, invert at h = -9.2

 60" pipe, invert at h = -24.7

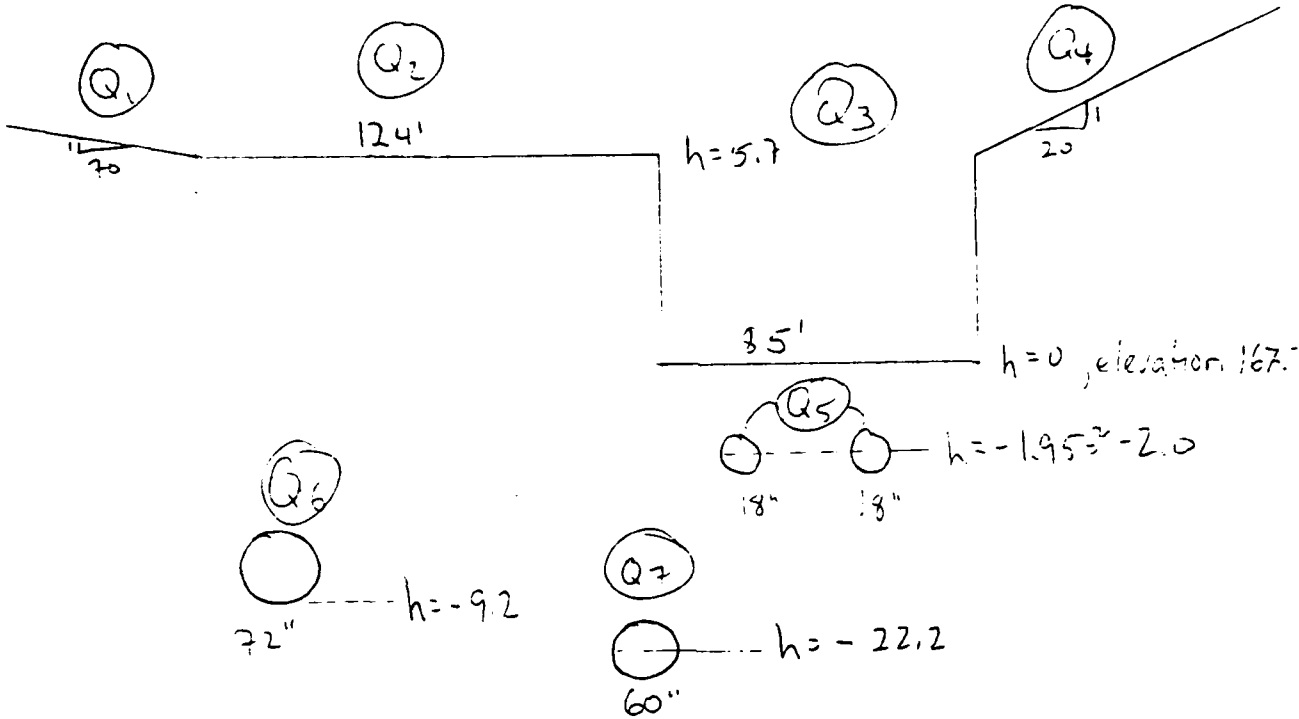
The discharge over this profile is equivalent to that over the simplified profile shown on p. 2.



There is another outlet from Harris Pond, called the West Dike. It is on the south shore of the pond, and leads to a smaller pond. The cross section is from field notes.

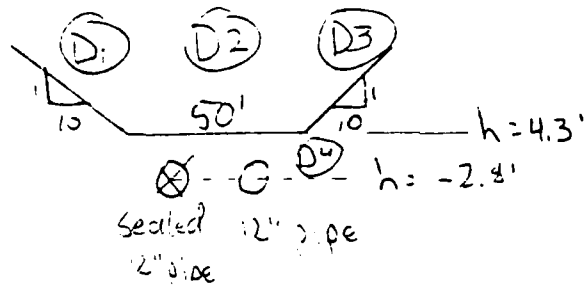

For Stage - Discharge calculations we will assume the the smaller pond to which the pipe leads remains at elevation 167.7 ($h = 0$).

Assume the 60" and 72" waste pipes are open both 18 pipes under the s... are open, and the 2" pipe under the s...

from $h=0$ to 4.3

$$Q_1 = Q_2 = Q_4 = Q_9 = D_1 = D_2 = D_3 = 0$$

$$Q_3 = 3.1 (85) h^{3/2} \quad (\text{Coefficient of 3.1 for broad-crested concrete weir})$$

$$Q_5 = 2 (C_d) \left(\frac{1}{4} \pi d^2\right) \sqrt{2g(h+2)}^* \\ = 2(.612) \left(\frac{1}{4} \pi (1.5)^2\right) \sqrt{64.4} \sqrt{h+2} \\ = 17.4 (h+2)^{1/2}$$

FIGURE 28, p. 35 of Rouse gives C_d for $\frac{d}{D} \approx \frac{1.5}{30} \rightarrow \sim .612$

$$Q_7 = .62 \left(\frac{1}{4} \pi (5)^2\right) \sqrt{64.4} (h+22.2)^{1/2} \\ = 97.7 (h+22.2)^{1/2}$$

FIGURE 28, p. 35 of Rouse gives C_d for $\frac{d}{D} \approx \frac{5}{30} \rightarrow \sim .62$

$$D_6 = .617 \left(\frac{1}{4} \pi (1)^2\right) \sqrt{64.4} \sqrt{h}$$

(the net head is equal to h because the pond to which D_4 discharges is assumed to remain at $h=0$, spillway elevation)

FIGURE 28, p. 35 of Rouse gives C_d for $\frac{d}{D} \approx \frac{1}{30} \rightarrow \sim .617$

$$= 3.9 (h)^{1/2}$$

Q_6 : The situation for Q_6 is this - The 72" pipe runs some 1500' to the gatehouse by Supply Pond Dam, which is at elevation ~ 31.5 . The flow then enters 2-48" lines and other lines. \Rightarrow seems likely that the 1500' of 72" line controls the flow. This pipe can be schematized:

\leftarrow Rouse Engineering Hydraulics, p. 35

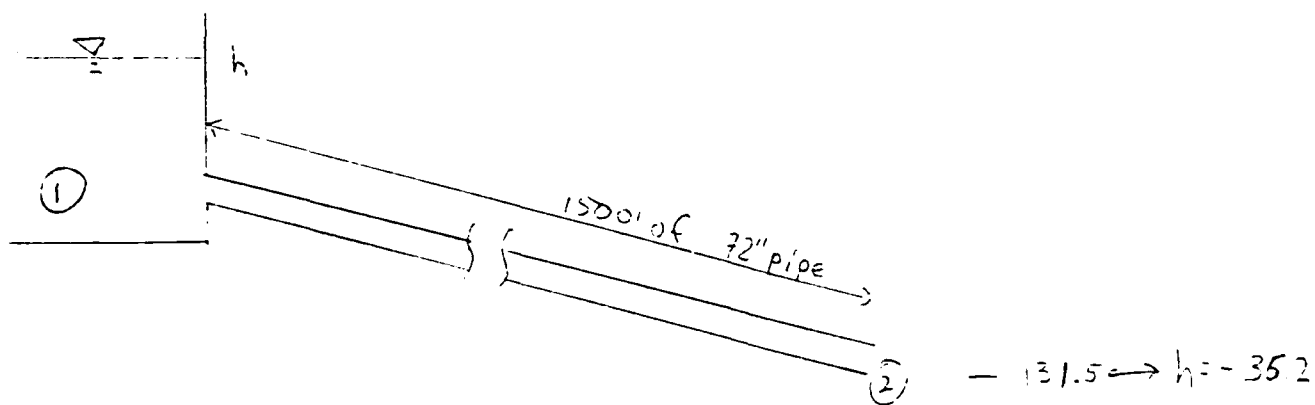

Apply Bernoulli's equation to points ① and ②:

$$\frac{V_1^2}{2g} + \frac{P_1}{\gamma} + z_1 = \frac{V_2^2}{2g} + \frac{P_2}{\gamma} + z_2 + h_{L_{1-2}}$$

$$V_1 = 0$$

$$\frac{P_1}{\gamma} + z_1 = h$$

$$P_2 = 0 \text{ (atmospheric)}$$

$$z_2 = -36.2$$

for $h_{L_{1-2}}$ use Darcy-Weisbach

$$h_L = f \frac{L}{d} \frac{V^2}{2g} \text{ where } f = \text{a friction factor.}$$

Assuming fully turbulent flow (Given this head, flow will be at high velocities & turbulent), $f = \text{Function of } \left(\frac{\epsilon}{D}\right)$

For cast iron pipe, $\epsilon = .00085'$. $D = 6'$

$$\frac{\epsilon}{D} = \frac{.00085}{6} = .000142 \rightarrow f = .0125$$

$$\text{So } h = \frac{V_2^2}{2g} + \frac{1500 (.0125) V_2^2}{6 \cdot 2g} - 36.2$$

$$h + 36.2 = \left(\frac{1}{64.4} + \frac{1500 (.0125)}{6 \cdot 64.4} \right) V_2^2$$

$$V_2^2 = \frac{h + 36.2}{.064}$$

$$V_2 = 3.95 (h + 36.2)^{\frac{1}{2}}$$

$$\begin{aligned} Q_6 &= \frac{1}{4} \pi D^2 (V_2) = \frac{1}{4} \pi 6^2 (3.95) (h + 36.2)^{\frac{1}{2}} \\ &= 111.7 (h + 36.2)^{\frac{1}{2}} \end{aligned}$$

from $h = 4.3$ to 5.7

$$D = D_3 = 2.8 (10) [(h - 4.3) (0.5) (h - 4.3)]^{3/2}$$

$$D_2 = 2.8 (50) (h - 4.3)^{3/2}$$

2.8 is a weir coefficient for broad-crested weirs over air.

all others unchanged

for $h > 5.7$

$$D = 2.8 (70) (h - 5.7) [(0.5) (h - 5.7)]^{3/2}$$

$$D_2 = 2.8 (124) (h - 5.7)^{3/2}$$

$$D_3 = 2.8 (20) (h - 5.7) [5 (h - 5.7)]^{3/2}$$

all others unchanged

∴ -7 gives a listing of a BASIC program which calculates
- discharge - storage relation D-6?

P. 6 of

```

LIST
100 REM: STAGE DISCHARGE PROGRAM FOR HARRIS DAM, JOB 165
110 REM: ON TAPE 10, FILE 51
120 PAGE
130 PRINT "DISCHARGE FROM HARRIS DAM AS A FUNCTION OF HEAD"
140 PRINT USING 150:
150 IMAGE / 2T"HEAD"30T"DISCHARGE"
160 PRINT USING 170:
170 IMAGE 1T"(FEET)"32T"(CFS)"
180 PRINT USING 190:
190 IMAGE10T"TOTAL"6X"DAM"6X"WEST"5X"6 FT"5X"5 FT"4X"SPILLWAY"3X"TOP OF"
200 PRINT USING 210:
210 IMAGE 20T"TOTAL"5X"DIKE"5X"PIPE"5X"PIPE"4X "+ PIPES"5X"DAM"
220 FOR H=0 TO 6 STEP 0.25
230 Q1=0
240 Q2=0
250 Q4=0
260 Q9=0
270 D1=0
280 D2=0
290 D3=0
300 Q3=3.1*85*H↑1.5
310 Q5=17.4*(H+2)↑0.5
320 Q6=111.7*(H+36.2)↑0.5
330 Q7=97.7*(H+22.2)↑0.5
340 D4=3.9*H↑0.5
350 IF H<=4.3 THEN 430
360 D1=2.8*10*(H-4.3)*(0.5*(H-4.3))↑1.5
370 D3=D1
380 D2=2.8*50*(H-4.3)↑1.5
390 IF H<=5.7 THEN 430
400 Q1=2.8*70*(H-5.7)*(0.5*(H-5.7))↑1.5
410 Q4=2.8*20*(H-5.7)*(0.5*(H-5.7))↑1.5
420 Q2=2.8*124*(H-5.7)↑1.5
430 T1=Q1+Q2+Q3+Q4+Q5+Q6+Q7

```

```

LIST
100 REM: STAGE-DISCHARGE RELATIONSHIP FOR HIGHWAY 3 BRIDGE
110 REM: SUPPLY POND DAM
120 REM: TAPE 10, FILE 50
130 PAGE
140 PRINT DISCHARGE OVER HIGHWAY 3 BRIDGE AS A FUNCTION OF HEAD"
150 PRINT USING 160:
160 IMAGE // 2T"HEAD"30T"DISCHARGE"
170 PRINT USING 180:
180 IMAGE 1T"(FEET)"32T"(CFS)"
190 PRINT USING 200:
200 IMAGE 10T" TOTAL CULVERT TOP OF ROAD"
210 PRINT " "
220 FOR H=0 TO 10 STEP 0.5
230 READ Q1
240 Q2=2.8*300*H↑1.5
250 Q3=2*2.8*20*H*(0.5*H)↑1.5
260 Q4=Q2+Q3
270 Q5=Q4+Q1
280 PRINT USING 290:H,05,01,04
290 IMAGE 2T,2D.1D,14D,16D,19D
300 NEXT H
310 DATA 5100,5160,5220,5280,5340,5400,5460,5520,5580,5640,5700
315 DATA 5760,5820,5880,5940,6000,6060,6120,6180,6240,6300
320 END

```

There are two possible scenarios from this point:

① Supply Pond Dam does not fail.

In that case, the 13,500 cfs would proceed down Pennichuck Brook, with an additional 700 cfs from the 32" pipe from Harris Pond, which feeds into the brook just below Supply Pond Dam. The total flow of 14,200 cfs would probably cause some structural damage to the pump station and conduit crossings immediately downstream of Supply Pond Dam. The 14,200 cfs peak flow would reach the Highway 3 Bridge across Pennichuck Brook with little attenuation (due to the steep slope and high, narrow channel). From ANCO FIS Cross sections, the Bridge cross section is:

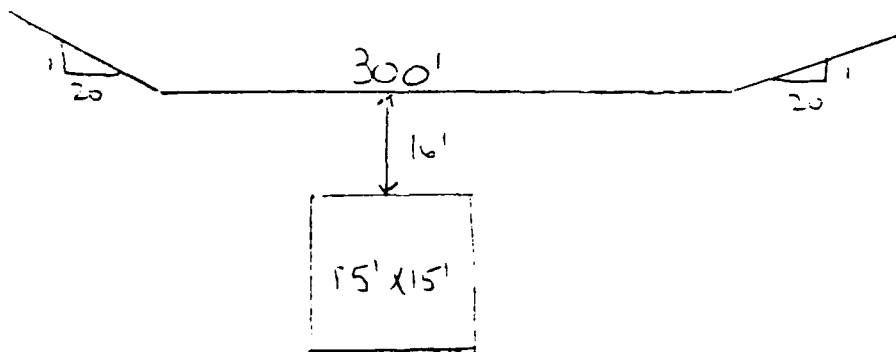

Not to scale

The BASIC program on page 19 calculates the Stage-Discharge curve shown on pp. 20-21. Culvert flows are from an interpolation of Chart 11 (for Culverts with Inlet Control) of Hydraulic Engineering Manual No. 5, FHWA, D-20

165 Dam Safety Harris Pond, #7 TCG, 1-23-79, p. 17 of

We will use the method suggested by the Corps of Engineers New England Division's "Rule of Thumb Guidelines for Estimating Downstream Dam Failure Flood Hydrographs."

$$Q_{p1} = 15,200 \text{ cfs}$$

H_1 = Height (as controlled by Supply Pond Dam)

$\approx 9.5'$ above spillway. (This assumes all gates open and stop logs in place, as discussed in the Supply Pond Report.)

V_1 = Volume of storage = H_1 (area of pond) (assumes no spreading).

$$V_1 = 2(9.5) = 190 \text{ Ac-FT.}$$

$Q_{p2T} = Q_{p1} \left(1 - \frac{V_1}{S}\right)$ = S = storage in Harris Pond at the time of failure = $1190 + 5.7(83.3) = 1670 \text{ Ac-FT.}$ (assuming no spreading).

$$Q_{p2T} = 15,200 \left(1 - \frac{190}{1670}\right) = 13,500 \text{ cfs}$$

$$H_{2T} = 9.1'$$

$$V_{2T} = 9.1(20) = 182$$

$$V_{AVG} = \frac{182 + 190}{2} = 186$$

$Q_{D2} = 15,200 \left(1 - \frac{186}{1670}\right) = 13,500 \text{ cfs} \rightarrow H_2 = 9.1'$, which is 5.0' above the Crest of Supply Pond Dam.

165 Dam Safety Harris Pond, #7 TCG, 1-23-79, p. 17cf

We will use the method suggested by the Corps of Engineers New England Division's "Rule of Thumb Guidelines for Estimating Downstream Dam Failure Flood Hydrographs."

$$Q_{p1} = 15,200 \text{ cfs}$$

H_1 = Height (as controlled by Supply Pond Dam)

$\approx 9.5'$ above spillway. (This assumes all gates open and stop logs in place, as discussed in the Supply Pond Report.)

V_1 = Volume of storage = H_1 (area of pond) (assumes no spreading).

$$V_1 = 2(9.5) = 190 \text{ Ac-FT.}$$

$Q_{p2T} = Q_{p1} \left(1 - \frac{V_1}{S}\right)$: S = storage in Harris Pond at the time of failure = $1190 + 5.7(83.3) = 1670 \text{ Ac-FT.}$ (assuming no spreading).

$$Q_{p2T} = 15,200 \left(1 - \frac{190}{1670}\right) = 13,500 \text{ cfs}$$

$$H_{2T} = 9.1'$$

$$V_{2T} = 9.1(20) = 182$$

$$V_{AVG} = \frac{182 + 190}{2} = 186$$

$Q_{p2} = 15,200 \left(1 - \frac{186}{1670}\right) = 13,500 \text{ cfs} \rightarrow H_2 = 9.1'$, which is 5.0' above the Crest of Supply Pond Dam.

STAGE-DISCHARGE CURVE AT SUPPLY POND DAM

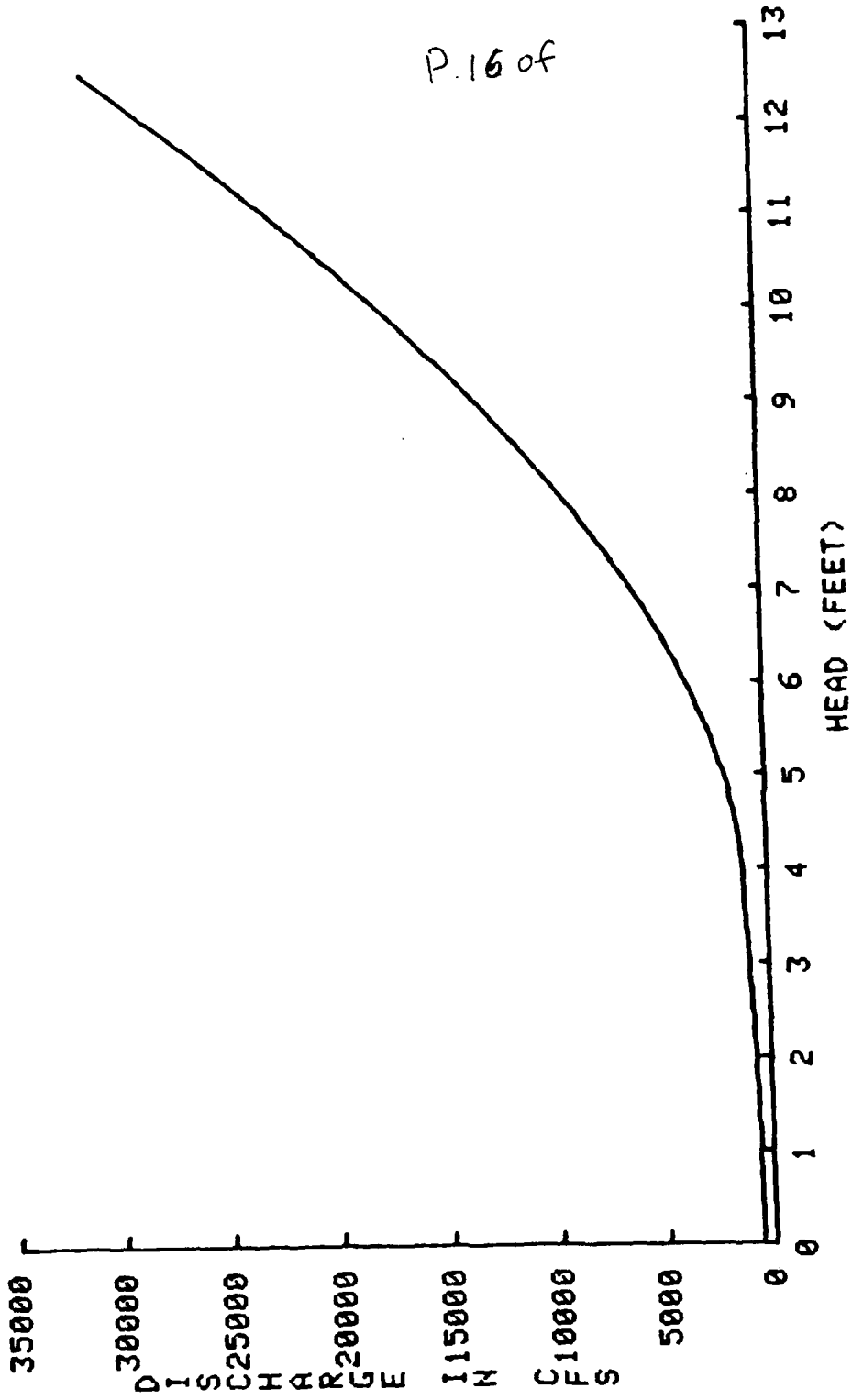

DISCHARGE FROM SUPPLY POND DAM AS A FUNCTION OF HEAD

HEAD (FEET)	TOTAL	WASTE PIPE	DISCHARGE (CFS)	GATES	SPILLWAY	TOP OF DAM
0.0	595	112	483	0	0	0
0.5	603	113	490	0	0	0
1.0	611	114	497	0	0	0
1.5	654	116	503	35	35	0
2.0	726	117	510	99	99	0
2.5	816	118	516	182	182	0
3.0	922	119	523	280	280	0
3.5	1041	121	529	391	391	0
4.0	1172	122	535	514	514	0
4.5	1410	123	542	649	649	97
5.0	1945	124	548	792	792	481
5.5	2713	125	554	945	945	1089
6.0	3675	126	560	1107	1107	1883
6.5	4823	128	566	1277	1277	2853
7.0	6158	129	571	1455	1455	4003
7.5	7689	130	577	1641	1641	5341
8.0	9378	131	583	1834	1834	6830
8.5	11229	132	589	2033	2033	8475
9.0	13240	133	594	2240	2240	10273
9.5	15392	134	600	2453	2453	12205
10.0	17681	135	605	2673	2673	14267
10.5	20104	136	611	2899	2899	16458
11.0	22658	137	616	3131	3131	18774
11.5	25342	138	621	3368	3368	21214
12.0	28155	139	627	3612	3612	23777
12.5	31095	141	632	3861	3861	26461

P. 15 of

```
440 Q2=2.8*55*(H-6.2)↑1.5
450 Q1=2.8*8.73*(H-8.3)*↑1.5
460 T1=Q2+Q3+Q4+Q5+Q6+Q7+Q8+Q9+Q1+S1
470 T2=Q8+Q9
480 T3=Q2+Q3+Q5+Q6+Q1+S1
490 PRINT USING 500:H,T1,Q7,T2,Q4,T3
500 IMAGE 2T,20.10,80,120,130,120,130
510 NEXT H
520 END
```

P. 13 of

```

LIST REM: STAGE DISCHARGE PROGRAM FOR SUPPLY POND DAM, JOB 165
1100 REM: ON TAPE 10, FILE 53
1120 PAGE "DISCHARGE FROM SUPPLY POND DAM AS A FUNCTION OF HEAD"
1130 PRINT USING 150:
1140 IMAGE / 2T"HEAD"30T"DISCHARGE"
1150 PRINT USING 170:
1160 IMAGE 1T"(FEET)"32T"<CFS>"
1170 PRINT USING 190:
1180 IMAGE 10T"TOTAL"5X"WASTE PIPE"5X"GATES"5X"SPILLWAY"5X"TOP OF DAM"
1190 FOR H=0 TO 12.5 STEP 0.5
210 Q5=0
220 Q1=0
230 S1=0
240 Q2=0
250 Q3=0
260 Q6=0
270 Q4=0
280 Q7=24.1*(H+21.5)↑0.5
290 Q8=57.6*(H+17.7)↑0.5
300 Q9=57.6*(H+17.5)↑0.5
310 IF H<1 THEN 460
320 Q4=3.3*30*(H-1)↑1.5
330 IF H<4.1 THEN 460
340 Q3=2.8*135*(H-4.1)↑1.5
350 Q2=2.8*(13.1*(H-4.1))*(<0.5*(H-4.1))↑1.5
360 IF H<4.5 THEN 460
370 Q5=2.8*150*(H-4.5)↑1.5
380 IF H<4.9 THEN 460
390 Q6=2.8*(45*(H-4.9))*(<0.5*(H-4.9))↑1.5
400 IF H<6.9 THEN 460
410 Q6=2.8*90*(H-5.9)↑1.5
420 S1=2.8*10*(H-6.9))*(<0.5*(H-6.9))↑1.5
430 IF H<8.3 THEN 460

```

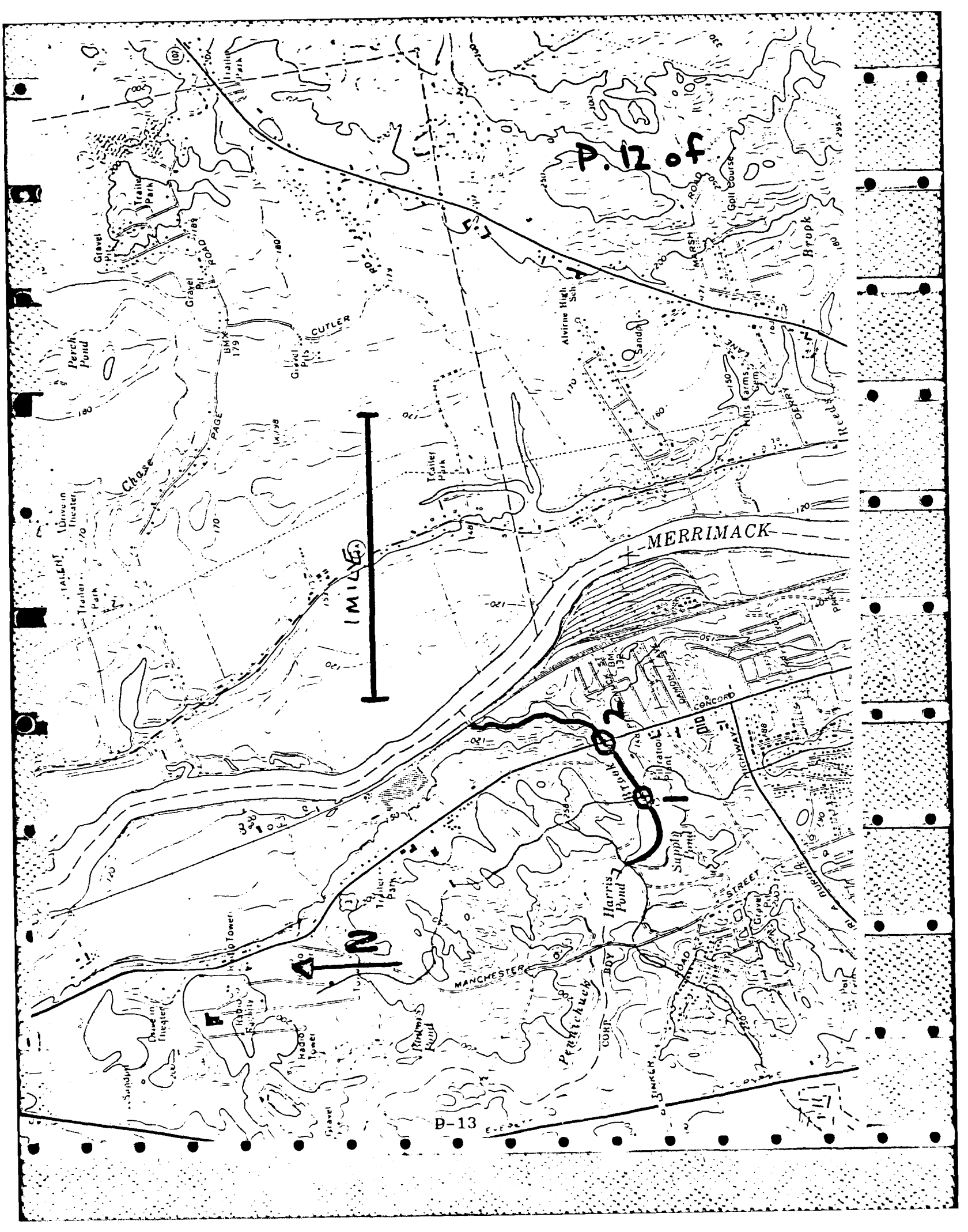

P. 12 of

1 MILE

MERRIMACK

B-13

65 Dam Safety Harris Dam, #7 - 66, 1-24-79, p. 1 of

W_b = width of breach, $\leq .4$ (dam width $\frac{1}{2}$ way to crest)

Assumed channel shape:

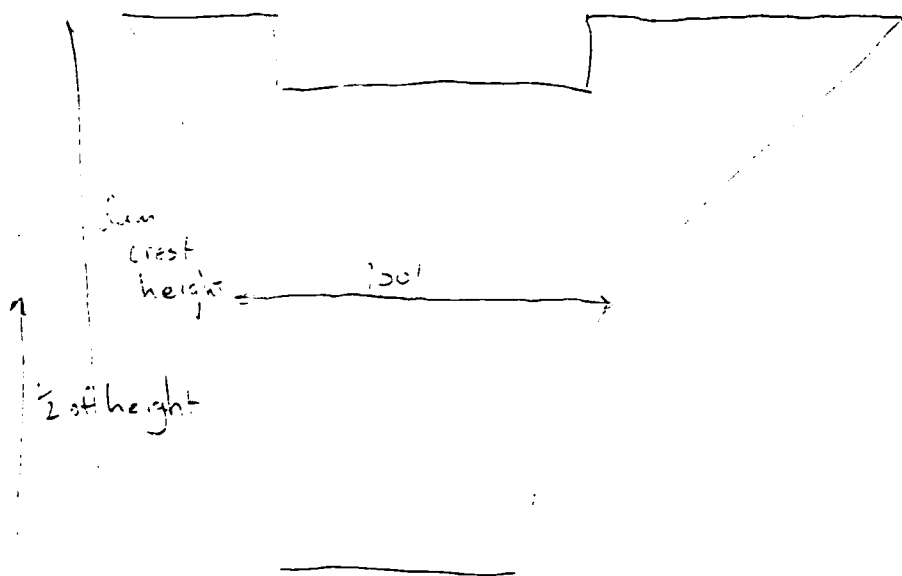

$$\text{So } W_b = .4(100) = 40$$

$$Q_{>1} = \frac{8}{3} (40) \sqrt{g} (30)^{3/2} = 11,050 \text{ cfs}$$

Peak failure outflow = $11,050 + 4140 \approx 15,200 \text{ cfs}$

This flow proceeds through Supply Pond and downstream. P. 12 shows the downstream areas of interest on Pennichuck Brook. (1) is Supply Pond Dam and the Pump Stations and conduit crossings in that area. (2) is the Highway 3 Bridge. Pp. 13-16 give a 2450 program which calculates the stage-discharge curve for Supply Pond, and a table and plot of that curve.

105 Dam Safety Harris Dam = 70, 200, 100

DAM FAILURE ANALYSIS

Assume that the dam fails with the water surface at the dam crest, elevation 173.4 (5.7'). The total discharge at the dam and the West dike, with all gates open, is about 5150 cfs. This flow is well above even the 500 year event. However, it could be reached if one of the dams upstream (Bower's or Holt's) were to fail or if the Route 101 A culvert were to be expanded so that it no longer cut the peak off of upstream inflow.

Peak failure outflow = normal outflow + Breach outflow

The normal outflow we are concerned with does not include that over the West Dike or through the 6' waste pipe, since these do not discharge at the dam.

$$\text{Normal outflow at 5.7'} = 5150 \text{ cfs} - 290 - 720 = 4140 \text{ cfs}$$

Breach outflow:

$$Q_{b1} = \frac{8}{27} W_b \sqrt{g} y_0^{3/2}$$

y_0 = height of water surface above backwater in Supply Pond. Elevation of water = 173.4. In Supply Pond, 4140 cfs probably gives about 4000 cfs of outflow, giving $h \approx 6.2$, an elevation of 143. $y_0 = 173.4 - 143 \approx 30'$

STAGE-DISCHARGE CURVE FOR HARRIS DAM

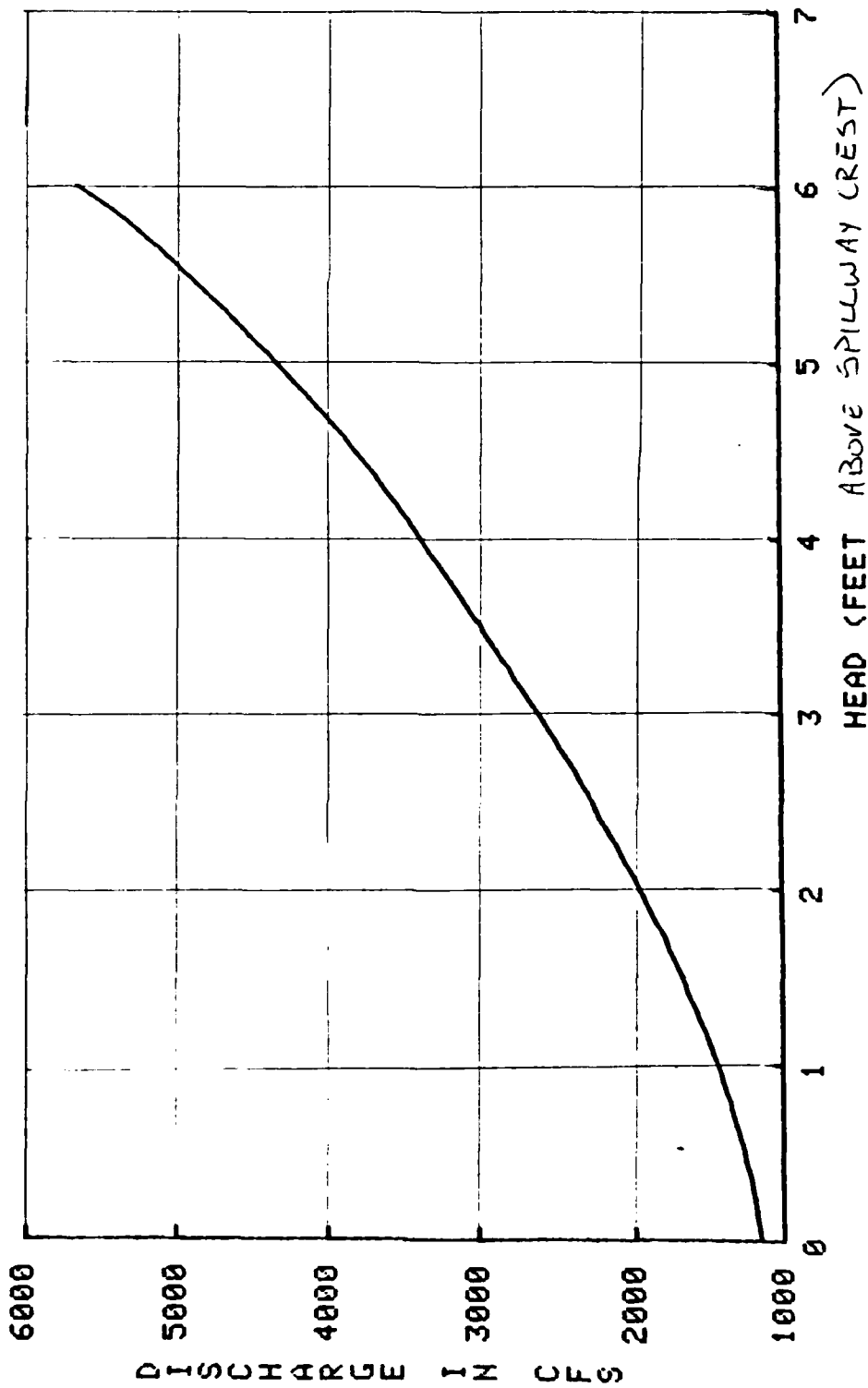

DISCHARGE FROM HARRIS DAM AS A FUNCTION OF HEAD ABOVE SPILLWAY CREST.

P. 8 of 4

HEAD (FEET)	TOTAL	DAM TOTAL	DISCHARGE (CFS)	WEST DIKE	6 FT PIPE	5 FT PIPE	SPILLWAY + PIPES	TOP OF DAM
0.00	1157	1157	0	0	672	460	25	0
0.25	1198	1196	2	2	674	463	59	0
0.50	1266	1263	3	3	677	465	121	0
0.75	1350	1347	3	3	679	468	200	0
1.00	1449	1446	4	4	681	471	294	0
1.25	1561	1556	4	4	684	473	400	0
1.50	1683	1678	5	5	686	476	517	0
1.75	1815	1810	5	5	688	478	644	0
2.00	1957	1951	6	6	690	481	780	0
2.25	2107	2101	6	6	693	483	925	0
2.50	2265	2259	6	6	695	486	1078	0
2.75	2431	2425	6	6	697	488	1240	0
3.00	2605	2598	7	7	699	490	1408	0
3.25	2787	2780	7	7	702	493	1584	0
3.50	2975	2965	8	8	704	495	1766	0
3.75	3166	3159	8	8	706	498	1955	0
4.00	3367	3359	8	8	708	500	2151	0
4.25	3573	3565	8	8	710	502	2352	0
4.50	3798	3777	21	13	713	505	2560	0
4.75	4048	3995	53	25	717	507	2773	0
5.00	4317	4219	99	53	719	510	2992	0
5.25	4604	4448	156	96	721	512	3217	4
5.50	4906	4682	224	156	723	514	3446	4
5.75	5229	4925	304	204	725	517	3682	4
6.00	5622	5228	394	294	726	519	3922	61

440 T2=D1+D2+D3+D4
450 T3=T1+T2
460 T4=Q3+Q5
470 T5=Q6+Q7
480 T7=Q1+Q2+Q4
490 PRINT USING 500:H,T3,T1,T2,Q6,Q7,T4,T7
500 IMAGE 1T,2D,9D,10D,8D,10D,9D,10D,9D
510 NEXT H
520 END

DISCHARGE OVER HIGHWAY 3 BRIDGE AS A FUNCTION OF HEAD

HEAD (FEET)	TOTAL	DISCHARGE (CFS) CULVERT	TOP OF ROAD
0.0	5100	5100	0
0.5	5464	5160	304
1.0	6100	5220	880
1.5	6932	5280	1652
2.0	7940	5340	2600
2.5	9112	5400	3712
3.0	10442	5460	4982
3.5	11928	5520	6408
4.0	13567	5580	7987
4.5	15360	5640	9720
5.0	17305	5700	11605
5.5	19404	5760	13644
6.0	21657	5820	15837
6.5	24066	5880	18186
7.0	26631	5940	20691
7.5	29353	6000	23353
8.0	32235	6060	26175
8.5	35278	6120	29158
9.0	38482	6180	32302
9.5	41851	6240	35611
10.0	45385	6300	39085

2, 20 of

STAGE-DISCHARGE CURVE AT HIGHWAY 3 BRIDGE

P. 210 F

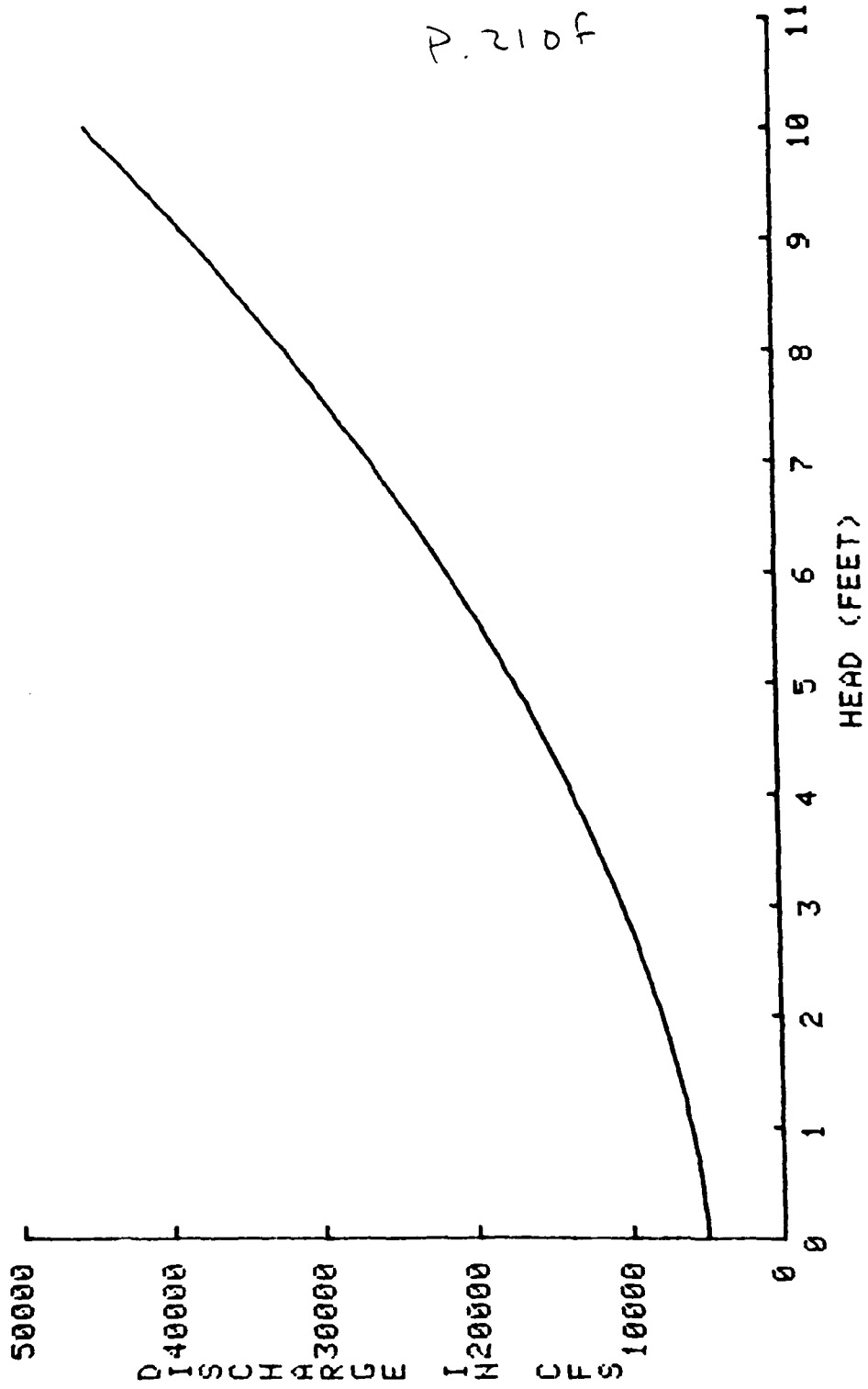

The flow of 14,200 cfs would overtop the roadway by about 4.2', and would probably cause some structural damage to the bridge. Also, due to the rapid rate of rise to be expected, there would be some potential for loss of life.

(2) Supply Pond Dam Fails

Outflow would be the normal outflow at this height (13,500 cfs) + failure outflow + 700 cfs (from 72" pipe).

$$Q_{p1} = \frac{8}{27} \sqrt{g} W_b y_o^{3/2}$$

from the Supply Pond Report, $W_b = 39'$

$$y_o = 30 + 5 = 35'$$

$$Q_{p1} = \frac{8}{27} \sqrt{g} (39) (35)^{3/2} = 13,600 \text{ cfs}$$

So total flow would be $14,200 + 13,600 = 27,800$.

The results would be the same as those of Scenario (1), except that the Highway 3 bridge would be overtopped by about 7.2'.

There is one structure along Pennichuck Brook between Supply Pond and the Highway 3 Bridge, a Pennichuck Water Works Sewage Treatment Plant. It is 30 ft. above the stream at its lowest point, and would not be affected by dam failure flows. Downstream of the Highway 3 Bridge, the Brook widens, and enters the Merrimack River, and

Test Flood Analysis:

Size Classification: Intermediate

Hazard Classification: Significant.

The Hazard Classification is based on the potential for damage to Supply Pond Dam, the pump station and conduits below the dam, and the Highway 3 bridge in the event of Dam Failure.

Test Flood: $\frac{1}{2}$ AMF to PMF.

The FIS work by AWC produces very low values of inflow to Harris Pond, with the 500 year inflow of 630 cfs equal to only 25.5 csm. The reason for these low flows is the character of the basin upstream of Harris Pond Dam. The drainage basin is swampy, with two large ponds (Bower's and Holts) upstream.

However, it is apparent from AWC's work that the primary control causing this low flow is the culvert across Pennichuck Brook under Route 101A. The culvert controls 19 sq. mi. of the drainage area and drastically reduces peak flows.

For the purpose of this Test Flood Analysis, it does not seem proper to allow a potentially temporary structure such as the Route 101A culvert - which might be enlarged or removed at any time - to determine test flood

INVENTORY OF DAMS IN THE UNITED STATES

STATE	DIVISION	CONCN	STATE	COUNTY	DIST.	NAME	LATITUDE	LONGITUDE	REPORT DATE
NH	122	MED	11	02		HARRIS POND DAM	7247.6	7128.8	21FEB79

POPULAR NAME	NAME OF IMPONDMENT
	HARRIS POND

REGION/BASIN	RIVER OR STREAM	NEAREST DOWNSTREAM CITY - TOWN - VILLAGE	DIST FROM DAM (MI.)	POPULATION
01 05	PENNICHUCK HOOK	NASHUA	5	70000

TYPE OF DAM	YEAR COMPLETED	PURPOSES	STATUS	HYDRAULIC	IMPONDING CAPACITIES	DIST OWN	FED R	PHV/PED	8CS A	DATE
VAHEPGCH	1870	S	35	35	1670	1190	N	N	N	21FEB79

REMARKS

L-NH16505 22-ESTIMATE

D/S HAS	SPILLWAY	MAXIMUM DISCHARGE (CFS)	VOLUME OF DAM (CFT)	POWER CAPACITY (KW)	NAVIGATION LOCKS															
					LENGTH	TYPE	WIDTH	DEPTH	NO.	NO.	NO.	NO.	NO.	NO.	NO.	NO.				
2	450	C	85	3630																

OWNER	ENGINEERING BY	CONSTRUCTION BY
PENNICHUCK WATER WORKS		

DESIGN	REGULATORY AGENCY	OPERATION	MAINTENANCE
NH WATER RES HD	NH WATER RES HD	NH WATER RES BD	NH WATER RES BD

INSPECTION BY	INSPECTION DATE	AUTHORITY FOR INSPECTION
COLONBERG ZOINO OUNNICLIFF ASSOC	31OCT78	PUBLIC LAW 92-367

REMARKS

APPENDIX E
INFORMATION AS CONTAINED IN
THE NATIONAL INVENTORY OF DAMS

165 Dam Safety Harris Dam, #7 TCG 3-2679, 2.27

1/2 PMF → 4940 cfs = 19' runoff

$$Q_{P2} = Q_{P1} \left(1 - \frac{\text{Stor}}{9.5} \right) = 4940 \left(1 - \frac{\text{Stor}}{9.5} \right)$$

Head above Spillway (') Stor. (cfs)

6	0	0	4940
	1	.055	4910
	5	.275	4800
5	6	.330	4730

Stage above Spillway (Feet)

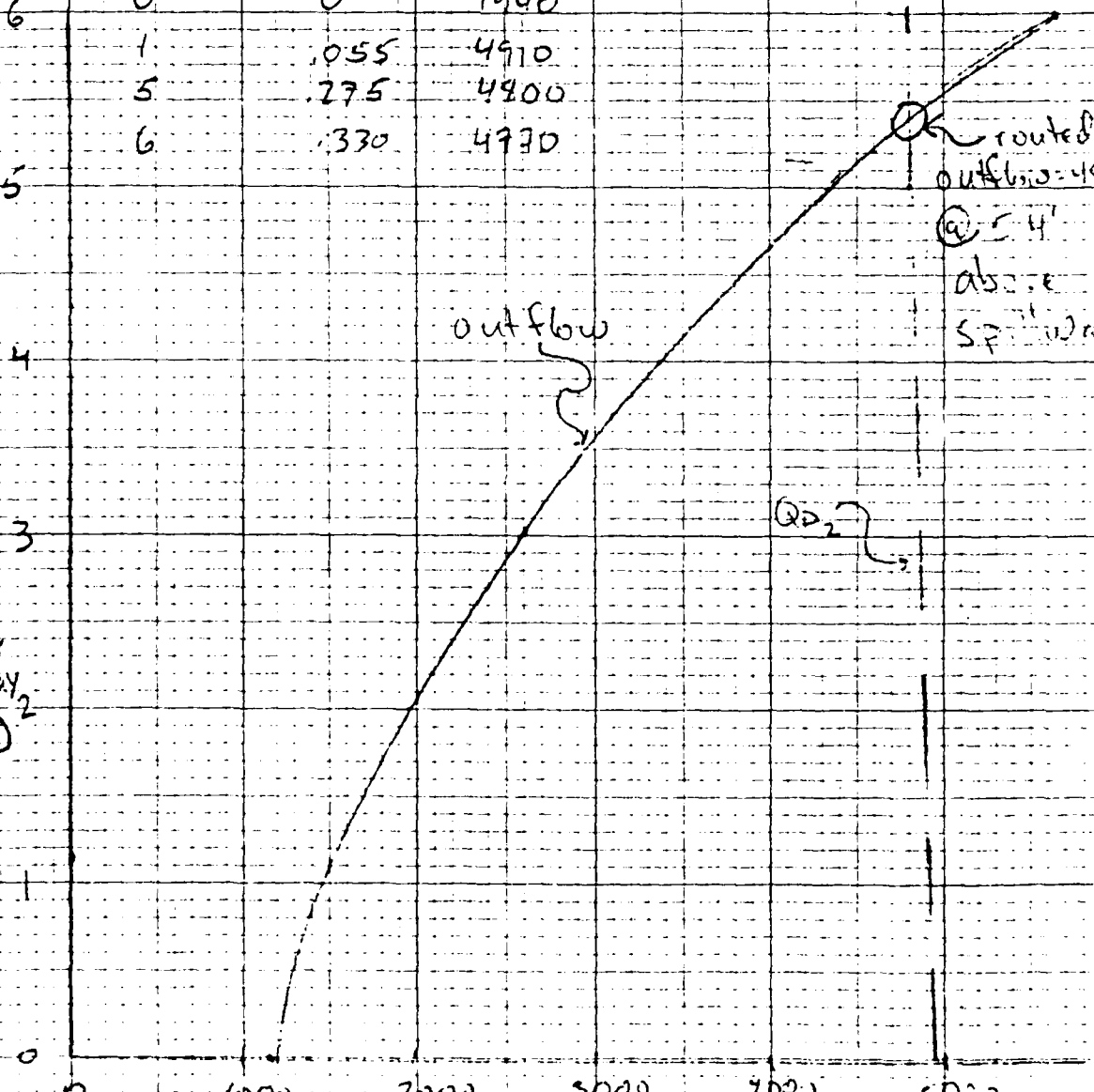

Reservoir Outflow (cfs)

(wastepipes open, no flashboards)

NO. 10 OF 1917
10 x 12 (11")
EIGHTEEN CENTS

Storage-Elevation Curve, Harris Pond

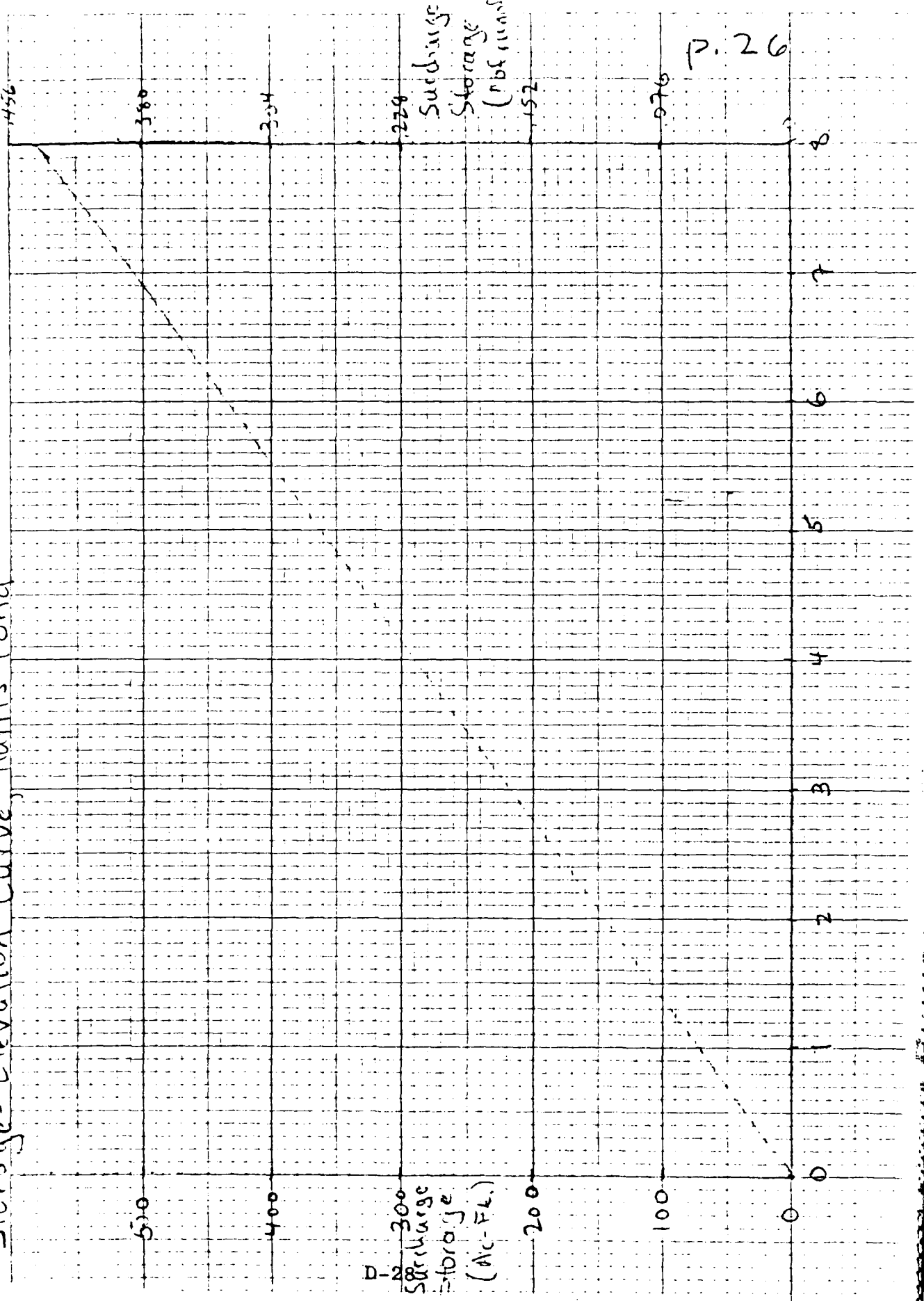

P. 2
Surcharge
Storage
(Ac.-Ft.)

Surcharge
Storage
(Ac.-Ft.)

P. 26

1057 - Harris Dam Study - "Harris Dam" Feb, 3-26-79, p. 27

inflows. Therefore, AEC's FIS flow values would not apply to this study.

Since the hazard for this dam is on the low side of significant, the $\frac{1}{2}$ PMF is the appropriate Test Flood.

The COE's "Maximum Probable Flood Peak Flow Rates" gives a $\frac{1}{2}$ PMF of 300 csm for a flat drainage area of 25 sq. mi. Because of the exceptional amount of storage - in swamps and ponds - upstream of Harris Pond, we will use 200 csm.

$$\text{Peak inflow} = 24.7 \text{ sq. mi. } (200 \text{ csm}) = 4940 \text{ cfs}$$

The Storage-Elevation curve for Harris Dam is on p. 26. The storage-Elevation curve assumes a pond surface of 73 acres and no spreading as the pond rises.

$$\begin{aligned} 1'' \text{ of runoff} &= 1'' \left(\frac{1 \text{ ft}}{12''} \right) \left(640 \frac{\text{ac}}{\text{mi}^2} \right) (24.7 \text{ mi. sq.}) \\ &= 1317 \text{ ac-ft. of storage} \end{aligned}$$

$$\rightarrow 1 \text{ ac-ft} = .00076'' \text{ of runoff}$$

$$\rightarrow 1 \text{ ft of rise} = 1(73)(.00076) = .055'' \text{ of runoff}$$

P. 27 gives a graphical routing of the Test Flood inflow through Harris Pond.

The discharge after accounting for storage is 4800 cfs, with a peak water surface elevation 5.4' above the spillway crest, at elevation 173.1' MSL. This is 3' below the top of the dam. If the waste gate were closed, the test flood would overtop the dam.

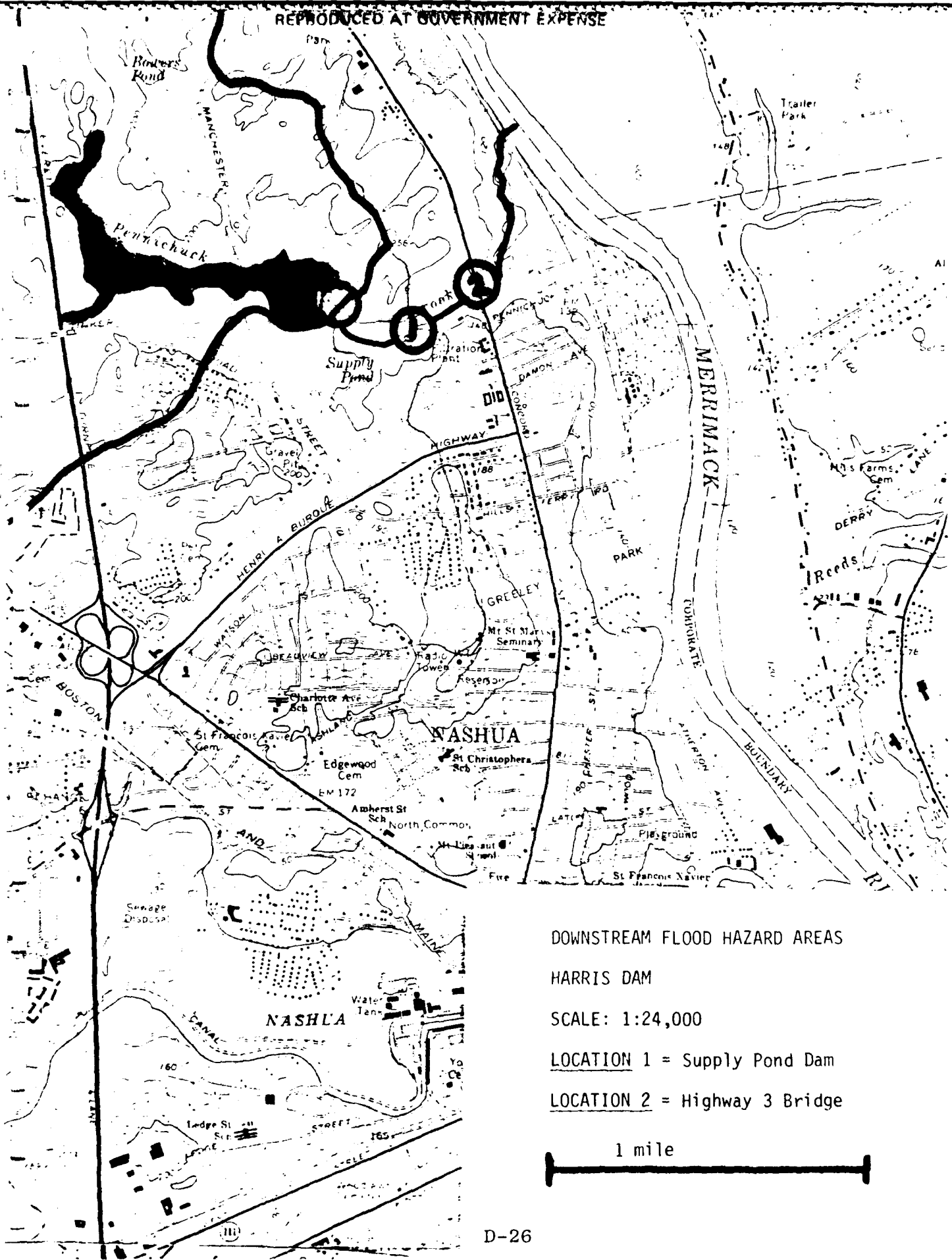

DOWNSTREAM FLOOD HAZARD AREAS

HARRIS DAM

SCALE: 1:24,000

LOCATION 1 = Supply Pond Dam

LOCATION 2 = Highway 3 Bridge



END

FILMED

8-85

DTIC