

AD-A156 158

NATIONAL PROGRAM FOR INSPECTION OF NON-FEDERAL DAMS
SILVER LAKE DAM (NH 0. (U) CORPS OF ENGINEERS WALTHAM
MA NEW ENGLAND DIV NOV 78

1/1

UNCLASSIFIED

F/G 13/13

NL

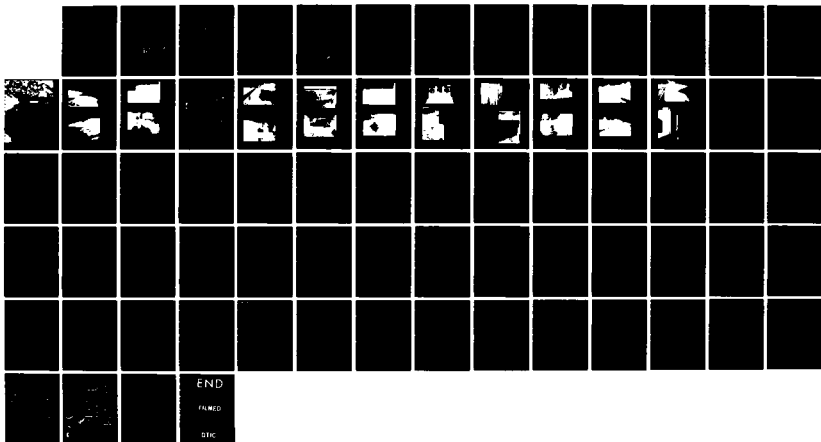

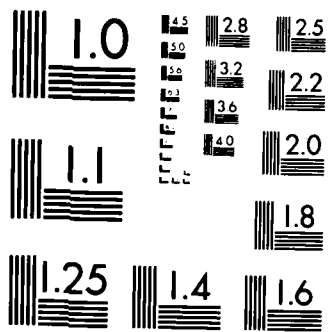

MICROCOPY RESOLUTION TEST CHART
NATIONAL BUREAU OF STANDARDS 1963-A

2

MS

AD-A156 150

CONNECTICUT RIVER BASIN
HARRISVILLE, NEW HAMPSHIRE

SILVER LAKE DAM

NH 00062

NHWRB NO. 109.01

PHASE I INSPECTION REPORT
NATIONAL DAM INSPECTION PROGRAM



DTIC
SELECTED
JUL 08 1985
G

DEPARTMENT OF THE ARMY
NEW ENGLAND DIVISION, CORPS OF ENGINEERS
WALTHAM, MASS. 02154

DISSEMINATION STATEMENT A
Approved for public release
Distribution Unlimited

NOVEMBER 1978

DTIC FILE COPY

85 06 20 057

DISCLAIMER NOTICE

THIS DOCUMENT IS BEST QUALITY PRACTICABLE. THE COPY FURNISHED TO DTIC CONTAINED A SIGNIFICANT NUMBER OF PAGES WHICH DO NOT REPRODUCE LEGIBLY.

UNCLASSIFIED

SECURITY CLASSIFICATION OF THIS PAGE (When Data Entered)

REPORT DOCUMENTATION PAGE		READ INSTRUCTIONS BEFORE COMPLETING FORM
1. REPORT NUMBER NH 00062	2. GOVT ACCESSION NO. ADA156150	3. RECIPIENT'S CATALOG NUMBER
4. TITLE (and Subtitle) Silver Lake Dam NATIONAL PROGRAM FOR INSPECTION OF NON-FEDERAL DAMS		5. TYPE OF REPORT & PERIOD COVERED INSPECTION REPORT
7. AUTHOR(s) U.S. ARMY CORPS OF ENGINEERS NEW ENGLAND DIVISION		6. PERFORMING ORG. REPORT NUMBER
9. PERFORMING ORGANIZATION NAME AND ADDRESS		8. CONTRACT OR GRANT NUMBER(s)
11. CONTROLLING OFFICE NAME AND ADDRESS DEPT. OF THE ARMY, CORPS OF ENGINEERS NEW ENGLAND DIVISION, NEDED 424 TRAPELO ROAD, WALTHAM, MA. 02254		10. PROGRAM ELEMENT, PROJECT, TASK AREA & WORK UNIT NUMBERS
14. MONITORING AGENCY NAME & ADDRESS (if different from Controlling Office)		12. REPORT DATE November 1978
		13. NUMBER OF PAGES 65
		15. SECURITY CLASS. (of this report) UNCLASSIFIED
		16a. DECLASSIFICATION/DOWNGRADING SCHEDULE
16. DISTRIBUTION STATEMENT (of this Report) APPROVAL FOR PUBLIC RELEASE: DISTRIBUTION UNLIMITED		
17. DISTRIBUTION STATEMENT (of the abstract entered in Block 20, if different from Report)		
18. SUPPLEMENTARY NOTES Cover program reads: Phase I Inspection Report, National Dam Inspection Program; however, the official title of the program is: National Program for Inspection of Non-Federal Dams; use cover date for date of report.		
19. KEY WORDS (Continue on reverse side if necessary and identify by block number) DAMS, INSPECTION, DAM SAFETY, Connecticut River Basin Harrisville New Hampshire Minnewawa Brook		
20. ABSTRACT (Continue on reverse side if necessary and identify by block number) The dam is an 80 ft. long, 12 ft. high dam consisting of stone, earth and concrete. The visual inspection did not disclose any findings that indicate an immediate unsafe condition. The general condition of the dam is good. The dam's spillway will not pass the required test flood. The wet area found at the toe downstream should be examined when there is no flow through the spillway to determine if it is resulting from seepage through the dam or from water through the rock slope from the spillway.		

SILVER LAKE DAM

NH 00062

NHWRB 109.03

CONNECTICUT RIVER BASIN
HARRISVILLE, NEW HAMPSHIRE

Accession For	
NTIS GRA&I	<input checked="" type="checkbox"/>
DTIC TAB	<input checked="" type="checkbox"/>
Unannounced	<input type="checkbox"/>
Justification	
By	
Distribution/	
Availability Codes	
Dist	Avail and/or Special
A/1	23 <i>sch</i>

PHASE I INSPECTION REPORT
NATIONAL DAM INSPECTION PROGRAM

DTIC
SELECTE
JUL 08 1985
S **D**
G

LETTER OF TRANSMITTAL
FROM THE CORPS OF ENGINEERS TO THE STATE
TO BE SUPPLIED BY THE CORPS OF ENGINEERS

NATIONAL DAM INSPECTION PROGRAM
PHASE I - INSPECTION REPORT
BRIEF ASSESSMENT

Identification No.: 00062
Name of Dam: Silver Lake Dam
Town: Harrisville
County and State: Cheshire, New Hampshire
Stream: Minnewawa Brook
Date of Inspection: August 16, 1978

Silver Lake Dam is an 80 foot long, 12 foot high dam consisting of stone, earth and concrete. Engineering data available consisted of two plans dated 1972 showing plan and elevation of the dam and details of additions and improvements made at that time. No construction specifications or design calculations were available.

The visual inspection of Silver Lake Dam did not disclose any findings that indicate an immediate unsafe condition. The general condition of the dam is good. The inspection revealed a small wet area midway between the outlet conduit and the left training wall of the sluiceway channel, a cracked right training wall in the sluiceway channel, and some slight obstruction of the downstream channel.

Silver Lake Dam's spillway will not pass the required test flood. The dam's spillway capacity is approximately 21 percent of the test flood and consequently, the dam would be overtopped by approximately 1.6 feet under test flood conditions.

It is recommended that the owner engage a qualified engineer to evaluate further the potential for overtopping and the inadequacy of the spillway. Also, provisions should be made by the owner to repair the cracked right training wall of the spillway and have the brush growing on the downstream rock face eradicated. The wet area found at the downstream toe should be examined when there is no flow through the spillway to determine if it is resulting from seepage through the dam or from water through the rock slope from the spillway.

The recommendations and remedial measures are described in Section 7 and should be addressed within two years after receipt of this Phase I - Inspection Report by the owner.

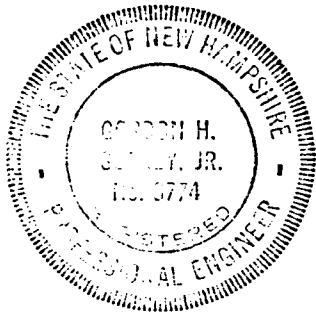

Gordon H. Slaney, Jr.
Gordon H. Slaney, Jr., P.E.
Project Engineer

Howard, Needles, Tammen & Bergendoff
Boston, Massachusetts

This Phase I Inspection Report on _____ Dam has been reviewed by the undersigned Review Board members. In our opinion, the reported findings, conclusions, and recommendations are consistent with the Recommended Guidelines for Safety Inspection of Dams, and with good engineering judgment and practice, and is hereby submitted for approval.

CHARLES G. TIERSCH, Chairman
Chief, Foundation and Materials Branch
Engineering Division

FRED J. RAVENS, Jr., Member
Chief, Design Branch
Engineering Division

SAUL COOPER, Member
Chief, Water Control Branch
Engineering Division

APPROVAL RECOMMENDED:

JOE B. FRYAR
Chief, Engineering Division

THIS SHEET TO BE FURNISHED BY THE CORPS OF ENGINEERS

PREFACE

This report is prepared under guidance contained in the Recommended Guidelines for Safety Inspection of Dams, for Phase I Investigations. Copies of these guidelines may be obtained from the Office of Chief of Engineers, Washington, D.C. 20314. The purpose of a Phase I Investigation is to identify expeditiously those dams which may pose hazards to human life or property. The assessment of the general condition of the dam is based upon available data and visual inspections. Detailed investigation and analyses involving topographic mapping, subsurface investigations, testing and detailed computational evaluations are beyond the scope of a Phase I Investigation; however, the investigation is intended to identify any need for such studies.

In reviewing this report, it should be realized that the reported condition of the dam is based on observations of field conditions at the time of inspection along with data available to the inspection team. In cases where the reservoir was lowered or drained prior to inspection, such action, while improving the stability and safety of the dam, removes the normal load on the structure and may obscure certain conditions which might otherwise be detectable if inspected under the normal operating environment of the structure.

It is important to note that the condition of a dam depends on numerous and constantly changing internal and external conditions, and is evolutionary in nature. It would be incorrect to assume that the present condition of the dam will continue to represent the condition of the dam at some point in the future. Only through continued care and inspection can there be any chance that unsafe conditions be detected.

Phase I inspections are not intended to provide detailed hydrologic and hydraulic analyses. In accordance with the established Guidelines, the Spillway Test Flood is based on the estimated "Probable Maximum Flood" for the region (greatest reasonably possible storm runoff), or fractions thereof. Because of the magnitude and rarity of such a storm event, a finding that a spillway will not pass the test flood should not be interpreted as necessarily posing a highly inadequate condition. The test flood provides a measure of relative spillway capacity and serves as an aide in determining the need for more detailed hydrologic and hydraulic studies, considering the size of the dam, its general condition and the downstream damage potential.

TABLE OF CONTENTS

<u>Section</u>	<u>Page</u>
Letter of Transmittal	
Brief Assessment	
Review Board Page	
Preface	i
Table of Contents	ii-iv
Overview Photo	v
Location Map	vi

REPORT

1. PROJECT INFORMATION	1-1
1.1 General	1-1
a. Authority	1-1
b. Purpose of Inspection	1-1
1.2 Description of Project	1-1
a. Location	1-1
b. Description of Dam and Appurtenances	1-2
c. Size Classification	1-2
d. Hazard Classification	1-2
e. Ownership	1-2
f. Operator	1-2
g. Purpose of Dam	1-2
h. Design and Construction History	1-3
i. Normal Operational Procedure	1-3
1.3 Pertinent Data	1-3
2. ENGINEERING DATA	2-1
2.1 Design Data	2-1
2.2 Construction Data	2-1
2.3 Operation Data	2-1
2.4 Evaluation of Data	2-1

<u>Section</u>	<u>Page</u>
3. VISUAL INSPECTION	3-1
3.1 Findings	3-1
a. General	3-1
b. Dam	3-1
c. Appurtenant Structures	3-2
d. Reservoir Area	3-3
e. Downstream Channel	3-3
3.2 Evaluation	3-3
4. OPERATIONAL PROCEDURES	4-1
4.1 Procedures	4-1
4.2 Maintenance of Dam	4-1
4.3 Maintenance of Operating Facilities	4-1
4.4 Description of any Warning System in Effect	4-1
4.5 Evaluation	4-1
5. HYDRAULIC/HYDROLOGY	5-1
5.1 Evaluation of Features	5-1
a. General	5-1
b. Design Data	5-1
c. Experience Data	5-1
d. Visual Observation	5-1
e. Overtopping Potential	5-1
f. Dam Failure Analysis	5-2
6. STRUCTURAL STABILITY	
6.1 Evaluation of Structural Stability	6-1
a. Visual Observation	6-1
b. Design and Construction Data	6-1
c. Operating Records	6-1
d. Post-Construction Changes	6-1
e. Seismic Stability	6-1

<u>Section</u>	<u>Page</u>
7. ASSESSMENT, RECOMMENDATIONS AND REMEDIAL MEASURES	7-1
7.1 Dam Assessment	7-1
a. Condition	7-1
b. Adequacy of Information	7-1
c. Urgency	7-1
d. Need for Additional Investigation	7-1
7.2 Recommendations	7-1
7.3 Remedial Measures	7-1
7.4 Alternatives	7-2

APPENDIXES

APPENDIX A - INSPECTION CHECKLIST	A-1
APPENDIX B - ENGINEERING DATA	B-1
APPENDIX C - PHOTOGRAPHS	C-1
APPENDIX D - HYDROLOGIC AND HYDRAULIC COMPUTATIONS	D-1
APPENDIX E - INFORMATION AS CONTAINED IN THE NATIONAL INVENTORY OF DAMS	E-1

b. Description of Dam and Appurtenances. Silver Lake Dam is a composite structure consisting of earth and stone, supplemented in some areas with a concrete wall. The structure is approximately 80 feet in length. The maximum structural height of the dam, according to existing plans, is about 12 feet from the base to the top of the concrete wall. The original dam constructed at this site consisted of two stone walls about 35 feet apart. The material placed between the walls is not known. Portions of the upstream face consist of a concrete retaining wall with a batter of 12 vertical to 1 horizontal. This concrete wall section extends approximately 55 feet from the left training wall of the sluiceway channel. The downstream face consists of a vertical stone wall.

The appurtenant structure consist of a sluiceway channel and an outlet works structure. The concrete sluiceway channel, with a maximum opening 12 feet in width and 8 feet in height (assuming all stoplogs removed) is located at the right abutment of the dam. The outlet works structure consists of a wooden control gate, gate house and stone culvert exiting to the river channel. The stone culvert has an opening 2.7 feet in width and 1.7 feet in height.

Figure 1, located in Appendix B, shows the plan of the dam, sluiceway channel and outlet works. Photographs of each structure are shown in Appendix C.

c. Size Classification. Intermediate (hydraulic height - 12 feet, storage - 4,060 acre-feet) based on storage ($\geq 1,000$ to 50,000 acre-feet) as given in the Recommended Guidelines for Safety Inspection of Dams.

d. Hazard Classification. The dam's potential for damage rates it as a significant hazard classification. A major breach could result in the loss of a few lives, damage to downstream roadways and damage to one or two houses.

e. Ownership. This dam is owned by the State of New Hampshire Water Resources Board.

f. Operator. This dam is maintained and operated by the State of New Hampshire Water Resources Board, 37 Pleasant Street, Concord, New Hampshire 03301. Chairman of the Water Resources Board is Mr. George M. McGee, Sr.; Mr. Vernon Knowlton is Chief Engineer. Telephone No. (603)271-1110.

g. Purpose of Dam. The purpose of this dam is primarily to provide a recreational lake with some flood control benefits which are described in Section 4, Operational Procedures.

NATIONAL DAM INSPECTION PROGRAM
PHASE I INSPECTION REPORT
SILVER LAKE DAM

SECTION 1
PROJECT INFORMATION

1.1 General

a. Authority. Public Law 92-367, August 8, 1972, authorized the Secretary of the Army, through the Corps of Engineers, to initiate a National Program of Dam Inspection throughout the United States. The New England Division of the Corps of Engineers has been assigned the responsibility of supervising the inspection of dams within the New England Region. Howard, Needles, Tammen & Bergendoff has been retained by the New England Division to inspect and report on selected dams in the State of New Hampshire. Authorization and notice to proceed were issued to Howard, Needles, Tammen & Bergendoff under a letter of July 12, 1978 from John P. Chandler, Colonel, Corps of Engineers. Contract No. DACW33-78-C-0356 has been assigned by the Corps of Engineers for this work.

b. Purpose

(1) To perform technical inspection and evaluation of non-Federal dams to identify conditions which threaten the public safety and thus permit correction in a timely manner by non-Federal interests.

(2) To encourage and prepare the states to initiate quickly effective dam safety programs for non-Federal dams.

(3) To update, verify and complete the National Inventory of Dams.

1.2 Description of Project

a. Location. Silver Lake Dam is located in the Town of Harrisville, New Hampshire. Silver Lake forms the headwaters of Minnewawa Brook. Minnewawa Brook flows in a generally westerly direction for a distance of approximately 7.5 miles to its confluence with Otter Brook in Keene, New Hampshire, thence continuing to flow in a westerly direction to its confluence with the Connecticut River. The dam is shown on U.S.G.S. Quadrangle, Monadnock, New Hampshire, with coordinates approximately N 42°56'55", W 72°08'00", Cheshire County, New Hampshire. Silver Lake Dam's location is shown on the Location Map immediately preceding this page.



Photo No. 19 - General view of roadway between dam and lake.



Photo No. 20 - Close-up detail of sluiceway structure.



Photo No. 17 - General view of downstream area (500 feet from dam).



Photo No. 18 - General view of downstream area (2,000 feet from dam).



Photo No. 15 - Roadway over downstream channel.



Photo No. 16 - Downstream channel between dam and roadway.

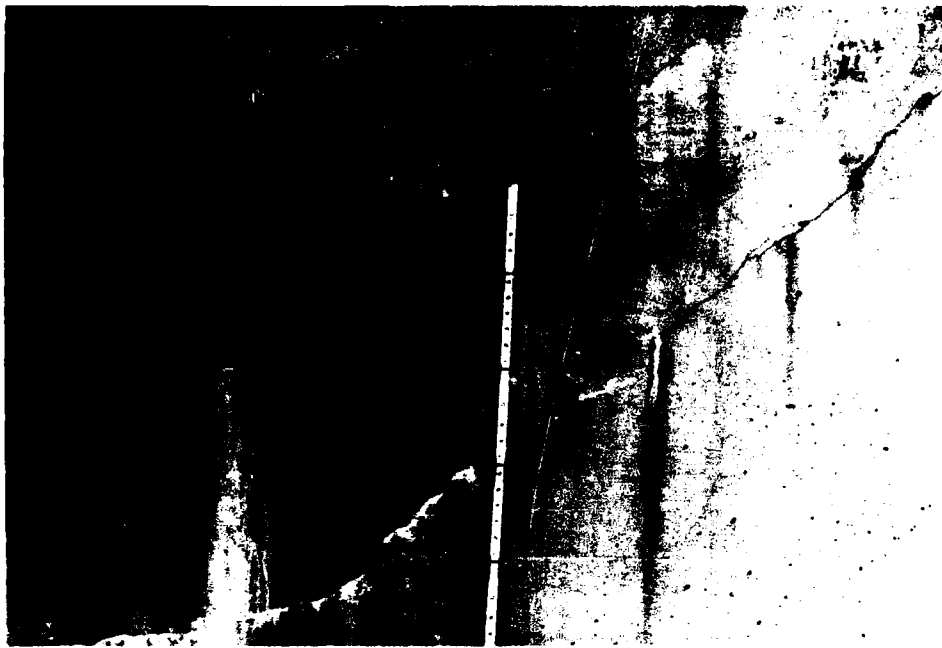

Photo No. 13 - Right wall of sluiceway structure.
Wall cracks at downstream area.

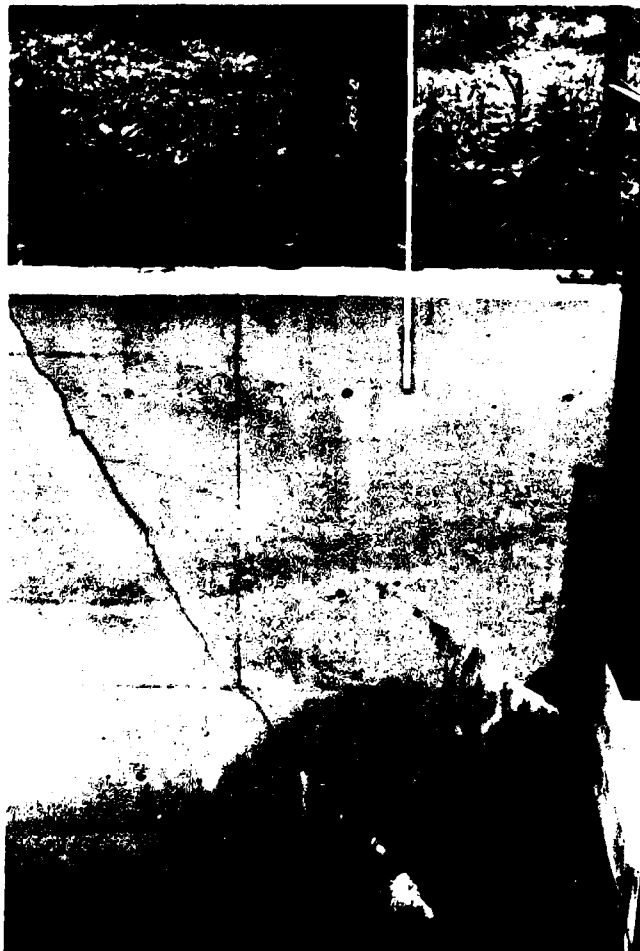

Photo No. 14 - Right wall
of sluiceway structure.
Wall cracks at high
water area.

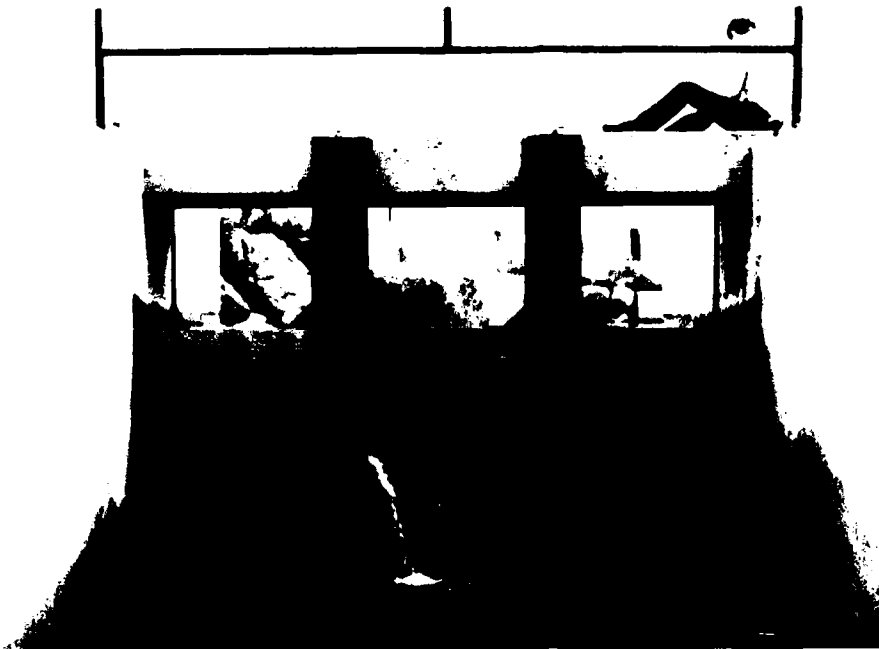

Photo No. 11 - General view of sluiceway structure.

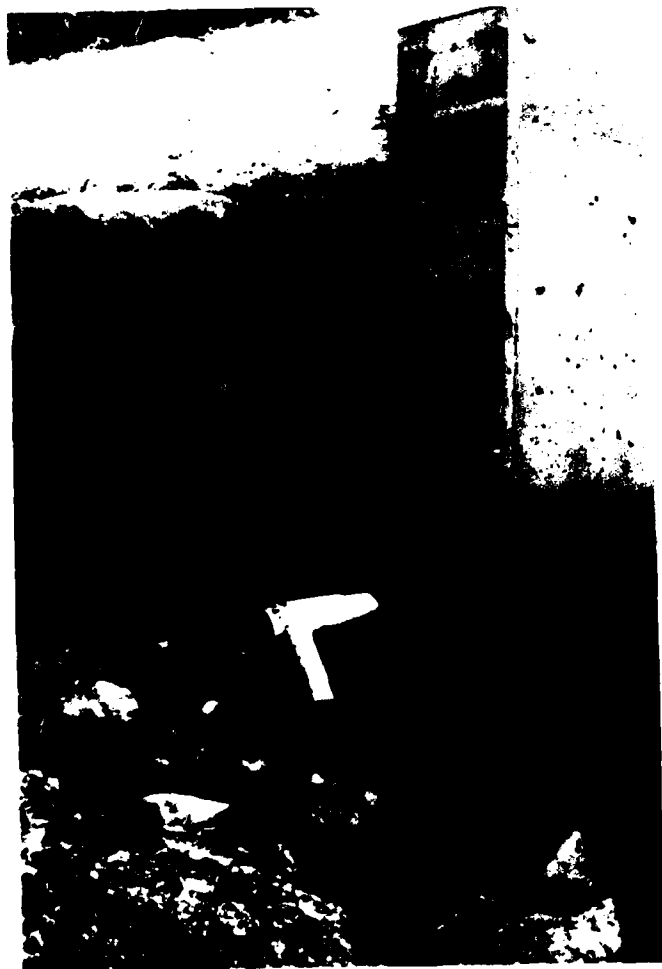

Photo No. 12 - Sluiceway training wall - drainage detail.



Photo No. 9 - Downstream face of dam.



Photo No. 10 - Wet area at toe of downstream face.

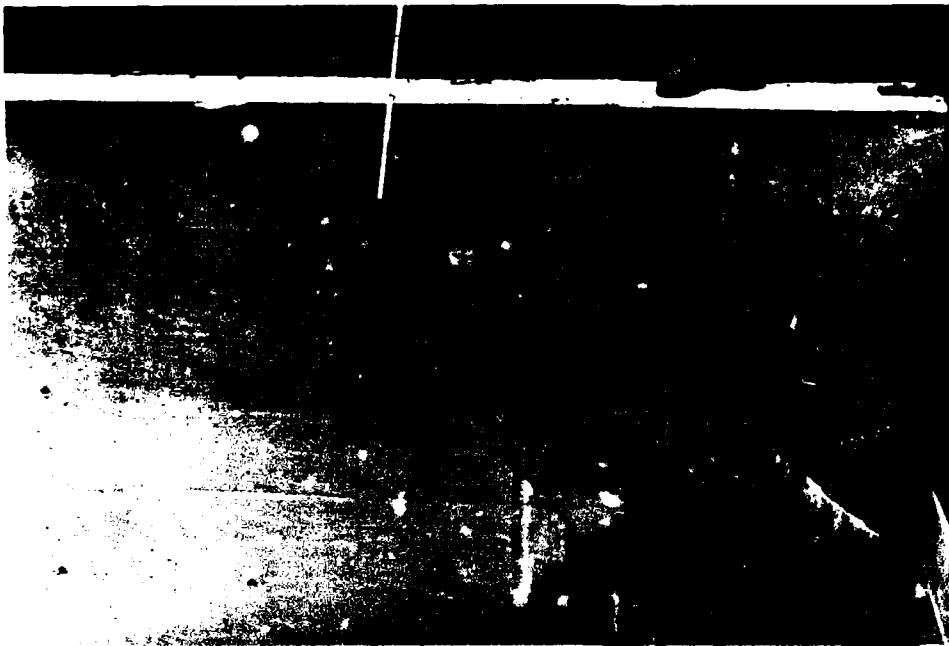

Photo No. 7 - Cracks in right training wall of sluiceway near stoplog section.

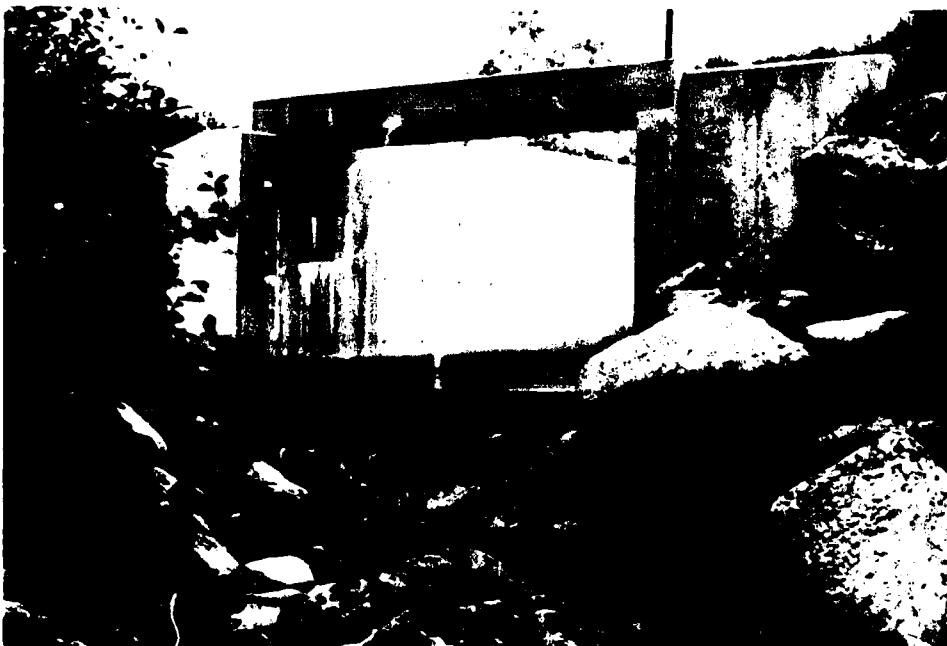

Photo No. 8 - General view of sluiceway channel.



Photo No. 5 - Close-up view of dam.



Photo No. 6 - Upstream face of dam.

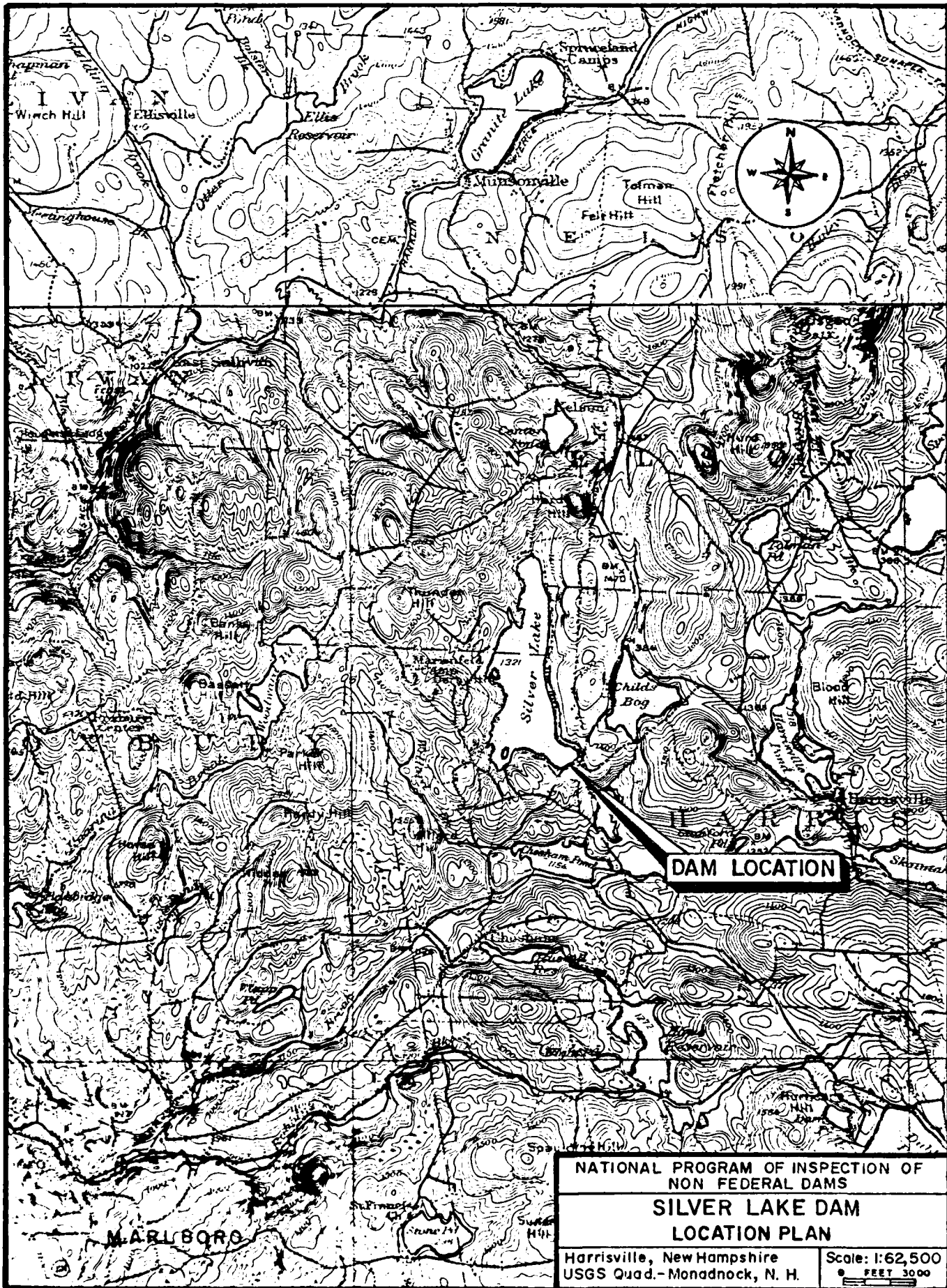

NATIONAL PROGRAM OF INSPECTION OF
 NON FEDERAL DAMS
SILVER LAKE DAM
LOCATION PLAN
 Harrisville, New Hampshire
 USGS Quad.-Monadnock, N. H.

Scale: 1:62,500
 FEET 3000



Photo No. 3 - General view of lake overlooking upstream roadway.



Photo No. 4 - General view of dam showing appurtenance structures from roadway.



Photo No. 1 - General view of Lake from roadway in front of dam (right side shown).



Photo No. 2 - General view of Lake (left side shown).



STILL LIFE DAM - Overview from right abutment

h. Design and Construction History. Little information is available regarding the original design and construction of Silver Lake Dam. A set of drawings (2 sheets) was prepared by the New Hampshire Water Resources Board in 1972 for the construction of the present sluiceway channel.

The drawings for this dam are available at the New Hampshire Water Resources Board. No in-depth design or construction data were disclosed for this dam.

i. Normal Operational Procedure. Silver Lake Dam is used primarily for the retention of Silver Lake which is used for recreational purposes. A secondary purpose of the dam and its resulting reservoir area is for control of winter and early spring runoff. The normal operational procedure for this dam is to remove the stoplogs in the sluiceway sometime in the month of October or November of each year thus lowering the reservoir level approximately 4 feet. The resultant available storage is used to control snow melt and heavy runoff during the winter and spring months. In May of each year, the stop logs are then reinserted into the sluiceway to the zero gage elevation, thus returning the reservoir level to its summertime recreational level.

1.3 Pertinent Data

a. Drainage Area. The drainage area above the Silver Lake Dam consists of approximately 2.2 square miles of rolling, heavily wooded hills. The periphery of Silver Lake is comprised of wooded area with some residences located near the reservoir.

The reservoir area itself contains no islands and is devoid of dead trees protruding through the surface or other visible impediments to navigation. There were some private docks or piers noted along the area inspected.

The watershed supporting Silver Lake is forested rolling terrain with very few flat areas. All areas in the basin are well vegetated with a few paved roads and housing. Topographic elevation in the watershed ranges from about 1,560 to 1,320 feet MSL.

There are few relatively small tributaries which drain into the lake. The longest of these tributaries is approximately 1.0 mile long with a vertical drop over its length of about 200 feet.

b. Discharge at Dam Site

(1) The outlet works for Silver Lake Dam consist of a 12 foot wide sluiceway and a 2.7 by 1.7 foot stone culvert. The lake behind the dam can be lowered 8 feet below the dam crest elevation 1324.5 by the removal of the wooden stoplogs in the sluiceway. The outlet culvert was designed to allow dewatering of the lake from the bottom of the sluiceway elevation 1316.5 to the original river bed elevation 1312+. However, due to the roadway culverts upstream of the dam, dewatering of the lake proper can only be accomplished to the invert elevation (1316.8) of these culverts. The small pond between the lake proper and the dam can be lowered to the original river bed by the use of the outlet works.

(2) This dam was subjected to the storm of 1938 without damage. Maximum discharge at this dam site is, however, unknown.

(3) The spillway capacity with a water surface at the top of the dam (elevation 1324.5) and assuming stoplogs in sluiceway in place at elevation 1321 is approximately 230 cfs.

(4) The spillway capacity with the water surface at the test flood elevation, again assuming the stoplogs in the sluiceway in place at elevation 1321, is approximately 420 cfs at an elevation of approximately 1326.1.

(5) The total project discharge at the test flood elevation of 1326.1 cfs estimated to be 1,100 cfs.

c. Elevation (feet above MSL) based on elevation of 1,321 shown on U.S.G.S. quad sheet assumed to be pool elevation.

- (1) Streambed at centerline of dam - 1,312+.
- (2) Maximum tailwater - unknown.
- (3) Upstream portal invert diversion tunnel - none.
- (4) Recreation pool - 1,321.
- (5) Full flood control pool - 1,316.5 (see Section 1.2.i).
- (6) Spillway crest - 1,321.
- (7) Design surcharge - unknown.
- (8) Top dam - 1324.5.
- (9) Test flood surcharge - 1326.1.

d. Reservoir (miles)

- (1) Length of maximum pool - 1.55.
- (2) Length of recreational pool - 1.55.
- (3) Length of flood control pool - 1.4₊.

e. Storage (acre-feet)

- (1) Recreation pool - 2870.
- (2) Flood control pool - 1380.
- (3) Spillway crest pool - 2870.
- (4) Top of dam - 4,060.
- (5) Test flood pool - 4,600.

f. Reservoir Surface (acres)

- (1) Recreation pool - 340.
- (2) Flood control pool - <340 Note: Vertical sides assumed.
- (3) Spillway crest - 340.
- (4) Test flood pool - 340+.
- (5) Top dam - 340+.

g. Dam

- (1) Type - stone, earth, concrete.
- (2) Length - 80 feet, overall.
- (3) Height - 12 feet (maximum).
- (4) Top width - 35 feet.
- (5) Side slopes - US = 1:17, DS = Vertical
- (6) Zoning - unknown.
- (7) Impervious core - unknown.
- (8) Cutoff - concrete wall 3.5 ft.₊.
- (9) Grout curtain - none.
- (10) Other - none.

h. Diversion and Regulating Tunnel

See Section j below.

i. Spillway

- (1) Type - stoplog sluiceway - vertical drop spillway.
- (2) Length of weir - 10.5 feet.
- (3) Crest elevation - 1,321.
- (4) Gates - none.
- (5) Upstream channel - approximate vertical rock wall below water surface, not completely visible from dam.
- (6) Downstream channel - the downstream channel between the dam and the downstream roadway, about 100 feet in length has a boulder strewn, sandy bottom and is lined lightly with trees. At the downstream roadway the channel passes through a 36 inch diameter culvert. Below the culvert, the downstream channel consists of a deep valley section with some small tree growth. This channel leads to a reservoir area approximately 2,500 feet downstream.

j. Regulating Outlets. The regulating outlet consists of a wooden control gate, wooden gate house and stone culvert located in the river bed with a maximum effective opening of 2.7 feet by 1.7 feet.

SECTION 2
ENGINEERING DATA

2.1 Design

No original design data were disclosed for Silver Lake. A set of drawings (2 sheets) dated 1972 showing additions and improvements made to the existing dam is the only design information found.

2.2 Construction

No construction records were available for use in evaluating the dam.

2.3 Operation

No engineering operational data were disclosed.

2.4 Evaluation

a. Availability. Little engineering data were available for Silver Lake Dam. A search of the files of the New Hampshire Water Resources Board revealed only a limited amount of recorded information.

b. Adequacy. Because of the limited amount of detailed data available, the final assessment and recommendations of this investigation are based on visual inspection and hydrologic and hydraulic calculations.

c. Validity. The field investigation indicated that the external features of Silver Lake Dam substantially agree with those shown on the available plans.

SECTION 3
VISUAL INSPECTION

3.1 Findings

a. General. The field inspection of Silver Lake Dam was made on August 16, 1978. The inspection team consisted of personnel from Howard, Needles, Tammen & Bergendoff and Geotechnical Engineers, Inc. A representative of the State of New Hampshire Water Resources Board was also present during portions of the inspection. Inspection checklists, completed during the visual inspection are included in Appendix A. At the time of the inspection, the water level was approximately 4 feet below the dam crest elevation. Water was passing through the stoplogs sluiceway approximately 1 inch deep. The upstream face of the dam could only be inspected above this water level.

b. Dam. Visual inspection of the embankment showed no signs of distress.

Upstream Slope

The upstream slope of the dam consists of a concrete wall which appears to be in good condition. There is no noticeable misalignment of this wall which would indicate excessive movement of its foundation or the embankment fill.

Crest

The crest of the dam is about 35 feet wide and has an excellent turf and grass cover, part of which can be seen in Photo 6.

Downstream

The downstream face of the dam consists of a nearly vertical rock wall shown in Photo 9. This wall is in good condition. There is some minor brush growing on the slope which should be eradicated. At a point approximately midway between the outlet conduit and the left training wall of the sluiceway channel, a small wet area was found at the base of the rock wall. This area is shown in Photo 10; the rule in the photo is extended to 4 feet. It was not possible to determine unequivocally if the source of the water in this area was seepage beneath or through the embankment. At the time of inspection, a small amount of water was flowing along the sluiceway channel floor along the left training wall and

entering a rock fill which communicates to the observed damp area. This sluiceway channel flow may be the source of the observed water.

c. Appurtenant Structures. Visual inspection of the concrete wall on the upstream face of the dam and sluiceway section did not reveal any evidence of stability problems, and the concrete appeared to be in good condition.

Visual inspection of the sluiceway section indicated that the right retaining wall has deteriorated since its construction. This right retaining wall has approximately 7 major horizontal and vertical cracks located in the vicinity of the service walkway decks. These cracks appear to be structural and were probably caused by excessive hydrostatic pressure induced by poor drainage in back of the wall. Also, the structural arrangement of this wall is such that earth pressures higher than active earth pressures could have been induced. The cantilever walls and the transverse decks rigidly connected could have prevented any wall movement and thus may have partially caused the observed cracking. This structural cracking was observed during the New Hampshire Water Resources Board inspection in 1975, and since that time additional drainage provisions have been made behind this wall, and at present it appears that the wall is in stable condition.

The outlet works consist of a wooden control gate, wooden gate house and stone culvert located in the river bed with a maximum effective opening of 2.7 feet wide by 1.7 feet high. The mechanically operated wooden gate and gate house, although old, are in good condition. Some rusting of the gate stem was noted. Due to concern for maintaining the water level in the lake, the gate was not operated but was reported to be operational by the representative from the New Hampshire Water Resources Board. Alignment of the stone culvert was good and the inside of the culvert was clean. The headwall of the outlet of the stone culvert was in good condition. There was, however, some small tree growth around the outlet, and the riprap has been overgrown with grass.

Visual inspection of the discharge channel showed it to be in generally good condition. The boulder strewn sandy channel is in good condition with no evidence of loose rock. There are a few overhanging trees that would appear to obstruct free flow of the channel discharge.

d. Reservoir Area. The reservoir slopes are generally covered with trees and brush. A more detailed description of the drainage area is included in Section 1.3 of this report. Cottages are scattered along the shoreline. The amount of siltation within the reservoir is unknown.

e. Downstream Channel. The downstream channel between the dam and the downstream roadway, about 100 feet in length, has a boulder strewn, sandy bottom and is lined lightly with trees, a few of which overhang the channel. The channel in this area is in good condition. At the downstream roadway the channel passes through a 36 inch diameter culvert which appears to be in good condition. Below the culvert, the downstream channel consists of a deep valley section with some small tree growth. This channel leads to a reservoir area approximately 2,500 feet downstream. There are no homes in the valley section between the dam and the downstream reservoir.

3.2 Evaluation

Visual examination did not disclose any immediate stability problems. The condition of the dam is generally good. The inspection revealed the following:

- (a) Small wet area midway between the outlet conduit and the left training wall of the sluiceway channel (not necessarily seepage but should be followed).
- (b) Cracked right training wall of the sluiceway channel.
- (c) Small tree and brush growth in downstream channel.

SECTION 4
OPERATIONAL PROCEDURES

4.1 Procedure

The Silver Lake Dam is used primarily for the retention of Silver Lake which is used for recreational purposes. A secondary purpose of the dam and its resulting reservoir area is for control of winter and early spring runoff. The normal operational procedure for this dam is to remove the stoplogs in the sluiceway sometime in the month of October or November of each year thus lowering the reservoir level approximately 4 feet. The resultant available storage is used to control snow melt and heavy runoff during the winter and spring months. In May of each year, the stoplogs are then reinserted into the sluiceway to the zero gage elevation, thus returning the reservoir level to its summertime recreational level.

4.2 Maintenance of Dam

This dam is visited by one of the State of New Hampshire Water Resources Board's dam operators approximately once per week. During these visits water levels are recorded, grass is cut as necessary, painting is done as necessary and any major deficiencies that may be noted are reported to the Water Resources Board. Occasional clearing of the brush on the embankment is also scheduled on a need basis.

In 1972, a new sluiceway channel was constructed with the stoplogs being used to control the lake level. Sometime after 1975, additional drainage facilities were added behind the right training wall of the sluiceway channel to alleviate hydrostatic pressures in this area.

4.3 Maintenance of Operating Facilities

Maintenance on the outlet works facilities is done on an as needed basis.

4.4 Description of Warning Systems

There are no warning systems in effect at this facility.

4.5 Evaluation

The current operation and maintenance procedures for Silver Lake Dam are inadequate to insure that all problems encountered can be remedied within a reasonable period of

time. The owner should establish a written operation and maintenance procedure as well as establishing a warning system to follow in event of flood flow conditions or imminent dam failure.

SECTION 5
HYDROLOGY AND HYDRAULIC ANALYSIS

5.1 Evaluation of Features

a. General. Silver Lake Dam is a composite structure consisting of stone, earth and concrete with a total length of approximately 80 feet and a maximum structural height of 12 feet. The appurtenant works consist of a sluiceway channel and an outlet works structure. The concrete sluiceway channel has a maximum opening of 12 feet by 8 feet high, assuming that all stoplogs are removed. The outlet works structure consists of a wooden control gate, gate house and stone culvert exiting to the river channel. The stone culvert has an opening 2.7 feet wide by 1.7 feet in height.

The dam is located on the upper reaches of what becomes Minnewawa Brook and creates an impoundment of water primarily used for recreational purposes. By lowering the reservoir level during the winter, the storage created behind the dam is also used to provide some control over snow melt and storm-water runoff during the winter months. Silver Lake Dam is classified as being intermediate in size having a maximum storage of 4,060 acre-feet.

b. Design Data. No hydrologic or hydraulic design data were disclosed for Silver Lake.

c. Experience Data. This dam was subjected to the storm of 1938 without damage. Maximum discharge at this dam site is, however, unknown.

d. Visual Observations. No evidence of damage to any portion of the project from overtopping was visible at the time of the inspection.

e. Overtopping Potential. As no detailed design and operational information are available, hydrologic evaluation was performed using dam information gathered by field inspection, watershed size and an estimated test flood equal to the Probable Maximum Flood (PMF) as determined by guide curves issued by the Corps of Engineers. Based on a drainage area of 2.2 square miles, it was estimated that the test flood inflow at Silver Lake Dam would be 4,680 cfs. Following the guidance for Estimating Effect of Surcharge Storage on Maximum Probable Discharge results in a test flood discharge of 1,100 cfs. This test flood discharge was determined assuming that the stoplogs in the sluiceway channel were

in place at elevation 1,321, that is summertime recreational elevation. With the stoplogs set at 1,321 elevation, the maximum spillway capacity of the top of the dam is 230 cfs (approximately 21 percent of the test flood discharge flow). With this spillway capacity, the test flood will cause the dam to be overtopped by approximately 1.6 feet.

f. Dam Failure Analysis. The impact of failure of the dam at maximum pool was assessed using the "Rule of Thumb" Guidance for Estimating Downstream Dam Failure Hydrographs issued by the Corps of Engineers. The analysis covered the reach extending from the dam to a point approximately 3 miles downstream. Failure of Silver Lake Dam at maximum pool would probably result in a downstream channel depth of approximately 8 feet between the dam and the reservoir area approximately 2,000 feet downstream. An increase in water depth of this magnitude would not affect any homes or other structures in this reach. Below this point, after some routing through Chesham Pond, a dam failure might destroy one of two houses and may result in the loss of less than 10 lives. Some damage to downstream roadways would also be likely.

SECTION 6
STRUCTURAL STABILITY

6.1 Evaluation of Structural Stability

a. Visual Observations. The visual inspection did not disclose any immediate stability problems.

b. Design and Construction Data. Some design drawings dated 1972 are available; however, they are not sufficient, and the safety of this dam must be determined mainly from information obtained by a visual examination.

c. Operating Records. No operating records were made available.

d. Post-Construction Changes. Since the original construction, a new sluiceway channel has been constructed at the right abutment of this dam. This sluiceway channel provides a maximum waterway opening of 12 feet wide by 8 feet high when all stoplogs are removed. This new channel was constructed in 1972. Sometime after 1972, the right training wall of the sluiceway channel developed cracks which were apparently due to hydrostatic pressure behind the wall. In approximately 1975, a new drain was constructed behind this wall to alleviate this pressure and prevent further cracking.

e. Seismic Stability. The dam is located in Seismic Zone 2, and in accordance with recommended Phase I guidelines does not warrant seismic analysis.

SECTION 7
ASSESSMENT, RECOMMENDATIONS AND REMEDIAL MEASURES

7.1 Dam Assessment

a. Condition. The visual inspection of Silver Lake Dam did not disclose any findings that indicate an immediate unsafe condition. The observed condition of the dam was good. The inspection revealed the following:

- (1) Small wet area midway between the outlet conduit and the left training wall of the sluiceway channel.
- (2) Cracked right training wall of the sluiceway channel.
- (3) Small tree and brush growth on the downstream face of the dam and downstream channel.
- (4) The inadequacy of the spillway to pass the test flood without overtopping the dam.

b. Adequacy of Information. The information made available is such that the assessment of the safety of the dam must be based primarily on the visual inspection and the past performance of the structure.

c. Urgency. The recommendations and remedial measures described in 7.2 and 7.3 should be accomplished within 2 years after receipt of this Phase I Inspection Report by the owner.

d. Need of Additional Investigation. The findings of the visual inspection do not warrant additional investigation.

7.2 Recommendations

It is recommended that the owner engage a qualified engineer to evaluate further the potential for overtopping and the inadequacy of the spillway.

7.3 Remedial Measures

(a) The brush growing on the downstream rock face should be eradicated.

(b) The cracks in the right training wall of the sluiceway channel should be repaired.

PAST INSPECTION REPORTS

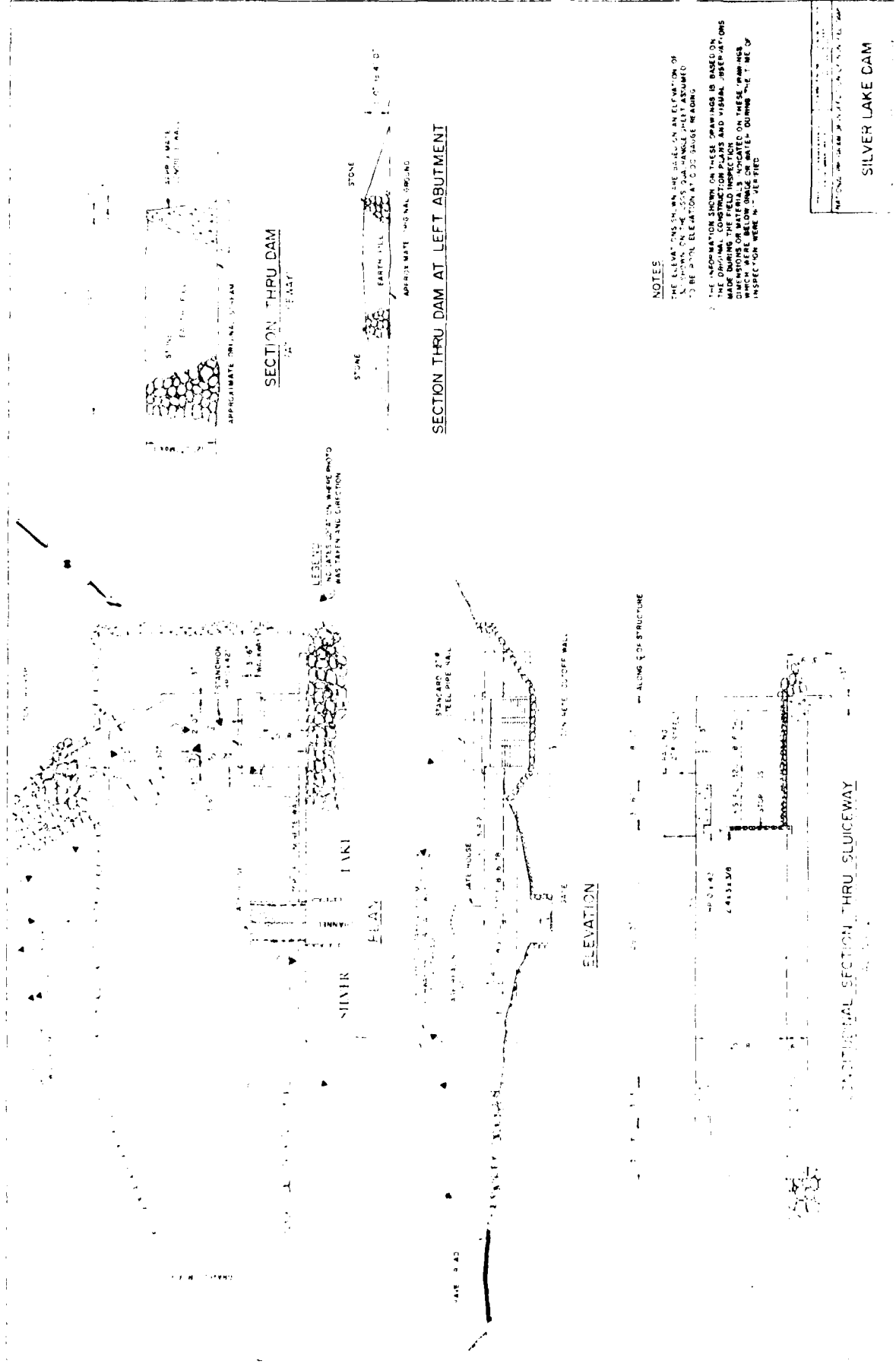

SECTION THRU DAM

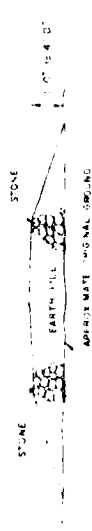

SECTION THRU DAM AT LEFT ABUTMENT

NOTES

- 1. THE ELEVATIONS ON THESE DRAWINGS ARE BASED ON AN ELEVATION OF 1000.00 FEET ON THE DAM ABUTMENT.
- 2. BE ABOVE ELEVATION AT 1000 GAUGE READING.
- 3. THE INFORMATION SHOWN ON THESE DRAWINGS IS BASED ON THE INFORMATION PROVIDED BY THE FIELD INSPECTOR AND VISUAL INSPECTIONS MADE DURING THE FIELD INSPECTION AND VISUAL INSPECTIONS.
- 4. DIMENSIONS OR MATERIALS INDICATED ON THESE DRAWINGS WHICH ARE BELOW UNDER OR AFTER DURING THE TIME OF INSPECTION WERE NOT CHECKED.

STRUCTURAL SECTION THRU SLUICED DAM

SILVER LAKE DAM

AVAILABLE ENGINEERING DATA

A set of drawings (2 sheets), dated 1972, showing additions and improvements made to the existing dam is available at the State of New Hampshire Water Resources Board, 37 Pleasant Street, Concord, New Hampshire 03301.

APPENDIX B

1. LIST OF DESIGN, CONSTRUCTION AND MAINTENANCE RECORDS
2. PAST INSPECTION REPORTS
3. PLANS AND DETAILS

PERIODIC INSPECTION CHECK LIST

PROJECT Silver Lake

DATE August 16, 1978

PROJECT FEATURE Service Bridge

NAME D. P. LaGatta

DISCIPLINE Structural/Hydraulic/Geotechnical Engr.

NAME S. Mazur, G. Slaney

AREA EVALUATED

CONDITION

OUTLET WORKS - SERVICE BRIDGE

No Service Bridge. Concrete walkway at sluiceway channel in good condition.

a. Super Structure

Bearings

Anchor Bolts

Bridge Seat

Longitudinal Members

Under Side of Deck

Secondary Bracing

Deck

Drainage System

Railings

Expansion Joints

Paint

b. Abutment & Piers

General Condition of Concrete

Alignment of Abutment

Approach to Bridge

Condition of Seat & Backwall

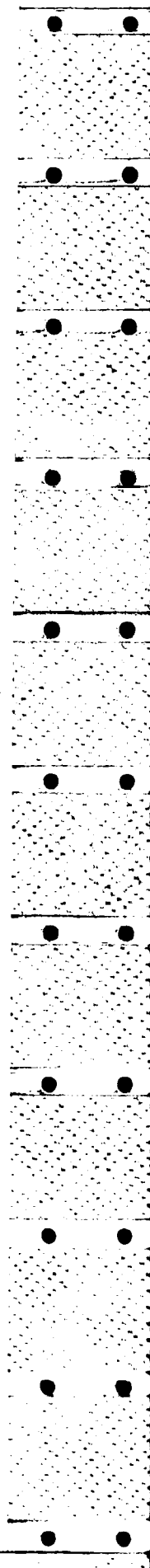

PERIODIC INSPECTION CHECK LIST

PROJECT Silver Lake

DATE August 16, 1978

PROJECT FEATURE Service Bridge

NAME D. P. LaGatta

DISCIPLINE Structural/Hydraulic/Geotechnical Engr.

NAME S. Mazur, G. Slaney

AREA EVALUATED	CONDITION
<p><u>OUTLET WORKS - SERVICE BRIDGE</u></p> <p>a. Super Structure</p> <ul style="list-style-type: none"> Bearings Anchor Bolts Bridge Seat Longitudinal Members Under Side of Deck Secondary Bracing Deck Drainage System Railings Expansion Joints Paint <p>b. Abutment & Piers</p> <ul style="list-style-type: none"> General Condition of Concrete Alignment of Abutment Approach to Bridge Condition of Seat & Backwall 	<p>No Service Bridge. Concrete walkway at sluiceway channel in good condition.</p>

PERIODIC INSPECTION CHECK LIST

PROJECT Silver Lake DATE August 16, 1978
 PROJECT FEATURE Outlet Structure Channel NAME D. P. LaGatta
 DISCIPLINE Structural/Hydraulic/Geotechnical Engr. NAME S. Mazur, G. Slaney

AREA EVALUATED	CONDITION
<p><u>OUTLET WORKS - OUTLET STRUCTURE AND OUTLET CHANNEL</u></p> <p>General Condition of Concrete</p> <p>Rust or Staining</p> <p>Spalling</p> <p>Erosion or Cavitation</p> <p>Visible Reinforcing</p> <p>Any Seepage or Efflorescence</p> <p>Condition at Joints</p> <p>Drain Holes</p> <p>Channel</p> <p>Loose Rock or Trees Overhanging Channel</p> <p>Condition of Discharge Channel</p>	<p>The outlet conduit is a stone conduit through dam which ends at the d.s. stone wall.</p> <p>None.</p> <p>Generally good condition.</p> <p>There is a 36-inch diameter conduit beneath a road which passes over the channel.</p>

PERIODIC INSPECTION CHECK LIST

PROJECT Silver Lake

DATE August 16, 1978

PROJECT FEATURE Transition and Conduit

NAME D. P. LaGatta

DISCIPLINE Structural/Hydraulic/Geotechnical Engr.

NAME S. Mazur, G. Slaney

AREA EVALUATED

CONDITION

OUTLET WORKS - TRANSITION AND CONDUIT

General Condition of Concrete

Rust or Staining on Concrete

Spalling

Erosion or Cavitation

Cracking

Alignment of Monoliths

Alignment of Joints

Numbering of Monoliths

Outlet drain conduit is a 2.7 foot x 1.7 foot stone conduit. Conduit is in good alignment. Joints are in good condition.

PERIODIC INSPECTION CHECK LIST

PROJECT Silver Lake DATE August 16, 1978
 PROJECT FEATURE Control Tower NAME D. P. LaGatta
 DISCIPLINE Structural/Hydraulic/Geotechnical Engrs. NAME S. Mazur, G. Slaney

AREA EVALUATED	CONDITION
<p><u>OUTLET WORKS - CONTROL TOWER</u></p> <p>a. Concrete and Structural</p> <p> General Condition</p> <p> Condition of Joints</p> <p> Spalling</p> <p> Visible Reinforcing</p> <p> Rusting or Staining of Concrete</p> <p> Any Seepage or Efflorescence</p> <p> Joint Alignment</p> <p> Unusual Seepage or Leaks in Gate Chamber</p> <p> Cracks</p> <p> Rusting or Corrosion of Steel</p> <p>b. Mechanical and Electrical</p> <p> Air Vents</p> <p> Float Wells</p> <p> Crane Hoist</p> <p> Elevator</p> <p> Hydraulic System</p> <p> Service Gates</p> <p> Emergency Gates</p> <p> Lightning Protection System</p> <p> Emergency Power System</p> <p> Wiring and Lighting System</p>	<p>Control tower and inlet structure are one and the same. Inlet structure gate is housed in a wooden gate house. Gate house is old but in good condition.</p> <p>Drain gate is hand operated. Reported to be operational although not opened due to concern over maintaining lake level. Gate stem is corroded at water level. Gear works in good condition. Gate below water and therefore not inspected.</p>

PERIODIC INSPECTION CHECK LIST

PROJECT Silver Lake

DATE August 16, 1978

PROJECT FEATURE Intake Channel, Structure

NAME D. P. LaGatta

DISCIPLINE Structural/Hydraulic and Geotechnical
Engineer

NAME S. Mazur, G. Slaney

AREA EVALUATED	CONDITION
<u>OUTLET WORKS - INTAKE CHANNEL AND INTAKE STRUCTURE</u>	
a. Approach Channel	
Slope Conditions	Approximate vertical rock wall below water surface, not completely visible from dam.
Bottom Conditions	
Rock Slides or Falls	
Log Boom	
Debris	
Condition of Concrete Lining	
Drains or Weep Holes	None.
b. Intake Structure	
Condition of Concrete	Good.
Stop Logs and Slots	See Gate.

PERIODIC INSPECTION CHECK LIST

PROJECT Silver Lake DATE August 16, 1978

PROJECT FEATURE Embankment Dam NAME D. P. LaGatta

DISCIPLINE Geotechnical Engineer NAME _____

AREA EVALUATED	CONDITION
<p><u>DAM EMBANKMENT</u></p> <p>Crest Elevation</p> <p>Current Pool Elevation</p> <p>Maximum Impoundment to Date</p> <p>Surface Cracks</p> <p>Pavement Condition</p> <p>Movement or Settlement of Crest</p> <p>Lateral Movement</p> <p>Vertical Alignment</p> <p>Horizontal Alignment</p> <p>Condition at Abutment and at Concrete Structures</p> <p>Indications of Movement of Structural Items on Slopes</p> <p>Trespassing on Slopes</p> <p>Sloughing or Erosion of Slopes or Abutments</p> <p>Rock Slope Protection - Riprap Failures</p> <p>Unusual Movement or Cracking at or near Toes</p> <p>Unusual Embankment or Downstream Seepage</p> <p>Piping or Boils</p> <p>Foundation Drainage Features</p> <p>Toe Drains</p> <p>Instrumentation System</p>	<p>Dam has an upstream concrete wall, wide earth section, and a rock wall d.s. face.</p> <p>None observed.</p> <p>No pavement.</p> <p>None observed.</p> <p>No misalignment on upstream concrete wall.</p> <p>Upstream wall in good condition.</p> <p>None observed.</p> <p>None observed.</p> <p>None observed.</p> <p>None.</p> <p>None observed.</p> <p>Small amount of seepage observed at base of d.s. rock wall midway between outlet and spillway structure.</p> <p>None observed.</p> <p>None.</p> <p>None observed.</p> <p>None.</p>

VISUAL INSPECTION CHECK LIST
PARTY ORGANIZATION

PROJECT Silver Lake

DATE August 16, 1978

TIME 9:00 a.m.

WEATHER Fair 70°

W.S. ELEV. 1320, U.S. 1312⁺ DN.S

PARTY:

- | | |
|--------------------------------|-----------|
| 1. <u>Gordon Slaney, HNTB</u> | 6. _____ |
| 2. <u>Stan Mazur, HNTB</u> | 7. _____ |
| 3. <u>Bob Fife, N.H.W.R.B.</u> | 8. _____ |
| 4. <u>D. P. LaGatta, GEI</u> | 9. _____ |
| 5. _____ | 10. _____ |

PROJECT FEATURE	INSPECTED BY	REMARKS
1. <u>Dam</u>	<u>Dan LaGatta</u>	
2. <u>Sluiceway Channel</u>	<u>Stan Mazur</u>	
3. <u>Outlet Works/Downstream Channels</u>	<u>Gordon Slaney</u>	
4. _____		
5. _____		
6. _____		
7. _____		
8. _____		
9. _____		
10. _____		

APPENDIX A

VISUAL CHECK LIST WITH COMMENTS

c) The wet area found at the downstream toe should be examined periodically to determine if it is resulting from seepage below the dam or from water through the rock slope from the spillway.

(d) Develop a written operational procedure to follow in the event of flood flow conditions or imminent dam failure.

(e) Continue the technical inspection program on a bi-annual basis.

7.4 Alternatives

There are no practical alternatives to the recommendations of Section 7.2 and 7.3 except that on an interim basis the owner may consider operating the reservoir at a lower level throughout the year so as to provide more storage for extreme flood events.

MEMORANDUM

TO: Peter Merkes and Donald Rapoza
FROM: Vernon A. Knowlton, Chief Engineer
DATE: September 16, 1975
SUBJECT: Site Inspection - September 12, 1975 - Silver Lake - Howe Reservoir

SILVER LAKE

In the abutment wall on the west side of the discharge chute downstream of the stop log section there is a diagonal crack from top to bottom. It appears to go completely through the wall. The back side behind the wall is up 1' below the top slope toward the wall and catches water. The grade should be raised 6" above the top of the wall, after considering constructing a drain behind the wall.

HOWE RESERVOIR

A seal cap 4" to 6" in diameter should be installed in the penstock seal to prevent plugging and freezing or thawing. A heavy coating of grease should be placed on top of the gate stem and adjoining area to prevent water from getting into the mechanism. A railing should be installed downstream of the stop log section and consideration should be given to the construction of a stop log box. The crack on the walk way at the south abutment of the stop log section should be sealed with appropriate material. Leakage through the abutment should be checked occasionally.

APPENDIX C

PHOTOGRAPHS

FOR LOCATION OF PHOTOS, SEE FIGURE 1
LOCATED IN APPENDIX B

APPENDIX D
HYDROLOGIC AND HYDRAULIC COMPUTATIONS

For Silver Lake Dam - Harrisville, N.H.

BASIC DATA

Drainage Area = 2.24 square miles
 (N.H. Water Control Commission data - verified by planimeter)

Based on Corps of Engineers guidelines;

SIZE CLASSIFICATION: INTERMEDIATE (Storage ≥ 1000 and $< 50,000$)

HAZARD POTENTIAL CLASSIFICATION: SIGNIFICANT

For dams with an INTERMEDIATE size classification and SIGNIFICANT hazard potential classification a test flood equal to the PMF is indicated in the Corps of Engineers guidelines.

Then for Silver Lake Dam analysis, TEST FLOOD = PMF

ELEVATION VS. WATER SURFACE AREA VS. VOLUME

Conditions	elevation, ft. USGS*	surface area, acres**	reservoir volume acre-ft.
top of dam	1324.5	340	4060
assumed operating level (USGS pool)	1321.0	340	2870
w/ all stopcocks removed from sluiceway	1316.5	340	1380

* 1321.0 ft. USGS assumed to be equal to 0 gauge elevation.

** water surface area above 1321.0 USGS assumed constant at 340 acres for purpose of Phase I analysis.

note: Prior to the analysis of Silver Lake dam for PMF test flood conditions, an independent hydraulic analysis of a roadway/culvert immediately upstream was performed to determine if the roadway should be a factor in further dam analyses. The results of this study indicate the roadway is overtopped by PMF due to limited culvert capacity. Accordingly roadway effects were neglected in further dam analysis. (See sheets 849 for culvert analysis.)

For **SILVER LAKE DAM**ESTIMATING EFFECT OF SURCHARGE STORAGE ON THE
MAXIMUM DISCHARGES.STEP 1- Determination of Peak Inflow from guide curvesDATA:

Drainage Area = 2.24 Sq. Mi. (NHWC data, verified by planimetry)

Surface Area = 340 Ac.

Volume Storage = 2870 Ac-Ft (At gauge El. 0.0')

Curve: Rolling Zone.

$$Q_p = 2,090 \frac{\text{CFS}}{\text{S.M.}} \times 2.24 \text{ S.M.} = 4,680 \text{ CFS.}$$

STEP 2A. Determine The Surcharge Height to pass Q_p FORMULA:

$$Q = C \times L \times H_c^{3/2} \quad (\text{Broad-Crested Weir})$$

$$\text{where: } C = 3.09 \checkmark$$

$$L = 123 \text{ Ft (Incl. the roadway and total crest)}$$

$$H_c = \text{Head (Ft) Unknown. (Above crest of Dam)}$$

A part of the flow past the dam, will be spilled over the stoplogs.
The capacity of the stoplog sluice (with stoplogs set at El. 0.0) is:

$$Q_s = C \times L \times H^{3/2} \quad (\text{For flow over the stoplogs.})$$

$$L = \text{Effective weir length} = L - 0.1HN \quad (\text{Approx.})$$

$$L = 10.5 \quad N = 10. \text{ (obstructions)} = 2$$

$$H = \text{Maximum Allowable Head} = 3.52'$$

$$C = 3.27 + 0.4 \frac{H}{P}$$

$$P = \text{Height of weir above channel bottom. (4.48')}$$

For SILVER LAKE DAM

$Q_c = 3.09 \times L \times H_c^{3/2}$ (For discharge over crest)
 where: $L = 111$ Feet

TABLE 1

WATER EL. M.S.L.	HEAD OVER SPILLWAY [ft]	DISCHARGE SPILLWAY	HEAD OVER CREST [ft]	DISCHARGE OVER CREST	TOTAL DISCHARGE
1321	0	0	-	-	0
1322	1.0	34.5	-	-	34.5
1324.5	3.5	232	0	0	232
1326	5.0	404	1.5	630	1034
1328	7.0	699	3.5	2245	2944
1330	9.0	1063	5.5	4424	5487

For Stage-Discharge curve see Fig. No 1

From Fig. No 1 the water EL. 1329.4 M.S.L. @ $Q_p = 4680$

B. DETERMINE VOLUME OF SURCHARGE (STOR₁) IN INCHES OF RUNOFF.

$$STOR_1 = \frac{(WATER EL. - 1321' MSL) \times 340^{AC} \times 12''}{2.24 \times 640} = 23.9''$$

$$= \frac{(1329.4' - 1321') \times 340^4 \times 12''}{2.24 \times 640 AC} = 23.9'' \text{ of Runoff}$$

C. To compute Q_{P2} use maximum runoff value (19")

$$\therefore Q_{P2} = Q_{P1} \times \left[1 - \frac{19''}{19''} \right] = Q_{P1} \times 0 = 0 \text{ CFS.}$$

STEP 3. A) Determine the surcharge for $Q_{P2} = 0$.

$$STOR_2 = 0$$

B) Compute $STOR_{AVERAGE}$ and Q_{P2}

$$STOR_{AVG} = \frac{STOR_1 + STOR_2}{2} = \frac{23.9'' + 0''}{2} = 11.95''$$

EFFECT OF SURCHARGE STORAGE (CONT.)

$$Q_{P_3} = Q_{P_1} \times \left[1 - \frac{\text{STOR}_{A16}}{19} \right] = 4,680 \times \left[1 - \frac{11.95'}{19} \right] = 1740 \text{ CFS}$$

$$Q_{P_3} = 1740 \text{ CFS} \checkmark$$

STEP 4. A. Determine Surcharge Height for $Q_{P_3} = 1,740 \text{ CFS}$
From Fig. 1 EL. = 1326.8

$$B. \text{STOR}_4 = \frac{(1326.8' - 1321')}{2.24 \text{ SM} \times 640 \text{ AC/SM}} \times 340 \text{ AC} \times 12''/\text{FT} = 16.51''$$

$$C. \text{STOR}_{\text{avg}} = \frac{11.95'' + 16.51''}{2} = 14.23''$$

$$D. Q_{P_4} = 4,680 \text{ CFS} \times \left[1 - \frac{14.23''}{19} \right] = 1,175 \text{ CFS}$$

STEP 5. A. Determine Surcharge Height for $Q_{P_4} = 1,175 \text{ CFS}$
From Fig. 1 EL. 1326.2'

$$B. \text{STOR}_5 = \frac{(1326.2' - 1321')}{2.24 \text{ SM} \times 640 \text{ AC/SM}} \times 340 \text{ AC} \times 12''/\text{FT} = 14.80''$$

$$C. \text{STOR}_{\text{avg}} = \frac{14.23'' + 14.80''}{2} = \underline{\underline{14.52''}}$$

$$D. Q_{P_5} = 4,680 \text{ CFS} \times \left[1 - \frac{14.52''}{19} \right] = 1,103 \text{ CFS}$$

$$\text{SLY } Q_{P_5} = 1,100 \text{ CFS} \rightarrow \text{EL. } 1326.1$$

$$\text{STOR}_{\text{avg}} = \underline{\underline{14.51''}} \quad \underline{\underline{\text{OK}}}$$

EFFECT OF SURCHARGE STORAGE (CONT.)

CONCLUSIONS:

1. The crest of dam will be overtopped by approx. 1.6 Feet by the test Flood outflow discharge
 $Q_p = 1,100$ CFS,
2. Sluiceway capacity = 420 CFS (@ Test Flood El. 1326.1)
3. Sluiceway capacity = 232 CFS (w/o. overtopping & with stoplogs at elevation 1321' MSL)
4. Sluiceway can pass approx the 21% of the test flood discharge = 1,100 CFS

For SILVER LAKE DAM

"RULE OF THUMB" USED TO ESTIMATE DOWNSTREAM
DAM FAILURE HYDROGRAPHS.

STEP No 1: Determine the reservoir storage (S)
in Ac.-Ft. at time of failure

Volume of Storage (Source NH Water Control Commission
at normal drawdown is equal to 2870 Ac.-Ft.

$$\begin{aligned} \text{Total } S \text{ (Volume)} &= 2870 \text{ Ac.-Ft.} + (3.5)340 \\ &= 4,060 \text{ Ac.-Ft.} \end{aligned}$$

STEP No 2: Determine peak failure outflow (Q_p)

$$Q_p = \frac{8}{27} \times W_b \sqrt{g} \varphi_0^{3/2}$$

Where $W_b = 40\%$ of length of actual dam (80 ft) = $.4 \times 80 = 32'$
 $\varphi_0 =$ total height from river bed to pool level
at failure

$$\varphi_0 = 12.00' \text{ (NH Water Control Commission data)}$$

$$\begin{aligned} Q_p &= \frac{8}{27} \times \sqrt{32.2} \times (.40 \times 80') \times (12.00')^{3/2} = \\ &= 2,236 \text{ CFS} \checkmark \quad \text{SAY: } 2,240 \text{ CFS} = Q_p \end{aligned}$$

STEP No 3: Develop a representative Stage-Discharge
rating for selected downstream reach.
See figure No 2

For SILVER LAKE DAM

SECTION # 1

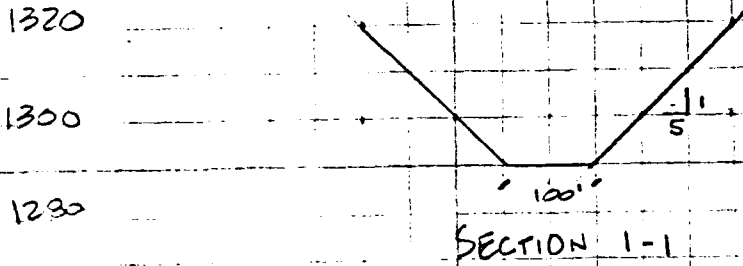

DLTA
 $n = 0.050$
 $B = 100'$
 $Z = 5$

PROFILE

SILVER LAKE

ELEVATION
 1320
 1300
 1230
 1260
 1240
 1220
 1200
 1180

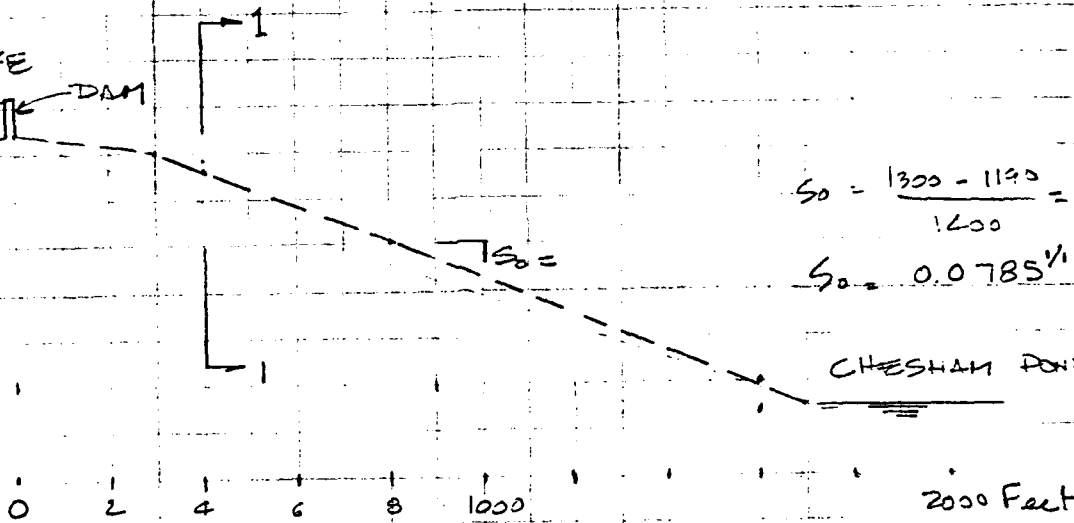

PROFILE OF CHANNEL BED
REACH 1

STAGE (FEET)

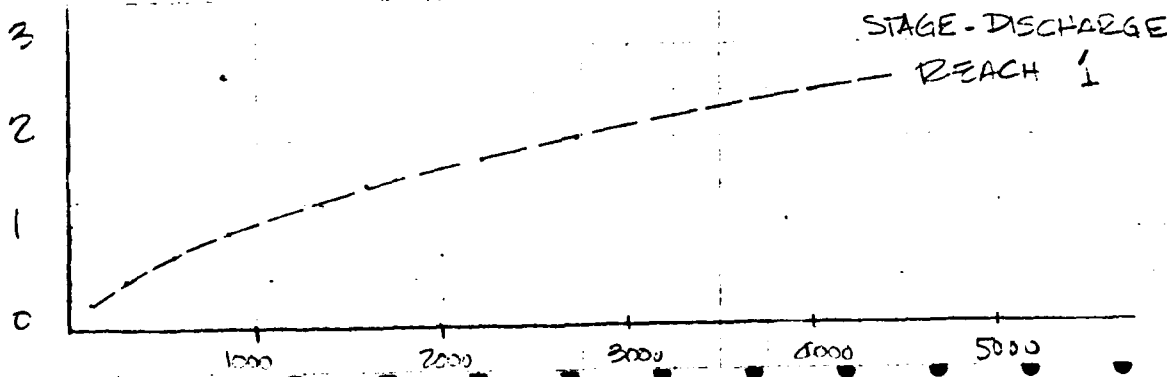

STEP 4: A) Compute Stage for a discharge of 2240 CFS

From Fig. 10.2 for $Q = 2,240 \rightarrow d = 1.78$ Feet.
 $A = 194 \text{ \#}$

$$V_1 = \frac{194 \text{ \#} \times 1700'}{43560} = 7.58 \text{ A-F}$$

$$V_1 \ll S/2 = 2200 \text{ A-F}$$

B) Determine $Q_{P2(\text{Final})}$

$$Q_{P2} = Q_{P1} \times \left(1 - \frac{7.58 \text{ AF}}{4060 \text{ AF}} \right) = 2,236 \text{ CFS}$$

COMMENT: A very slight reduction of the peak is obtained in reach 1 due to the small storage produced at this stage ($d=1.78'$).

The discharge from reach 1 will go through two ponds; since there are no data available the volume of storage of the two ponds assuming the depth will be increased by 5 feet, will attenuate the peak flow by using the following formula:

$$Q_{P2} = Q_{P1} \times \left[1 - \frac{\text{STORAGE AVAILABLE IN PONDS}}{S} \right]$$

$$\therefore S = 4,060 \text{ A-F}$$

$$A_1 = 32 \text{ Ac}, \quad A_2 = 37.2 \text{ Ac}, \quad A_{\text{TOTAL}} = 119.2 \text{ Ac}$$

$$Q_{P1} = 2,236 \text{ CFS}$$

$$\therefore Q_{P2} = 2,236 \times \left[1 - \frac{119.2 \text{ Ac} \times 5 \text{ FT}}{4,060 \text{ AF}} \right] = 1,933 \text{ CFS}$$

$$\text{SAY } Q_{P2} = 1,930 \text{ CFS}$$

SILVER LAKE DAM

GENERAL INFORMATION:

LOCATION:

Town: Harrisville ; COUNTY: Creshire
 STREAM: SILVER LAKE

GENERAL DATA:

Drainage Area: 2.24 Sq. Mi

Surface Area: 340 Acres.

Volume = 2,870 Ac. Ft (At crest Elev.)

DLU DATA:

LENGTH OF CREST = 80 Feet

STRUCTURAL HEIGHT = 12 Feet.

WATER ELEVATION = 1321' above m.s.l. (U.S.G.S.)

O' Gauge Elev. = 1,321' M.S.L

HYDRAULIC ANALYSIS OF CULVERTS:

Before the analysis on the dam is done, a hydraulic capacity checking on the two culverts under the embankment of the roadway that is located immediately upstream of the dam should be performed.

Data:

Size of Pipe = 36"

Number of Pipes = 2

Length of Pipe = 35'

Headwall w/ Wingwalls

Allowable Headwater = 3' (Above pipe inverts)

Tailwater elevation = 3.6' (Above pipe inverts)

Available Head = 3' - 3.6' = -0.6'

Formula:

$$H = \left[0.0155 (1 + K_e) + \frac{0.85 n^2 \times L}{Q^{4/3}} \right] \left(\frac{Q}{A} \right)^2$$

For SILVER LAKE DAM

Where:

- n = Manning's Coef.
- Q = Flow (CFS.) Thru each pipe
- A = Sectional Area of one pipe (A = 7.06')
- ke = Entrance Loss Coefficient. (0.5)
- R = Hydraulic Radius (R = 0.75)
- H = Allowable Head (Ft) w/o. overtopping the R/W

Computing the flow:

$$Q_T = \left[\frac{H \times}{0.0155 \times 15 + \frac{0.45 \times 0.012^2 \times 35}{(0.75)^{4/3}}} \right]^{1/2} \times A \times 2 =$$

$Q_T = 181.6 \text{ CFS.} < \text{PMF}$

Note: Q_T checked w/ Figure C-2 (isograph) in Handbook of Concrete Pipe Hydraul.

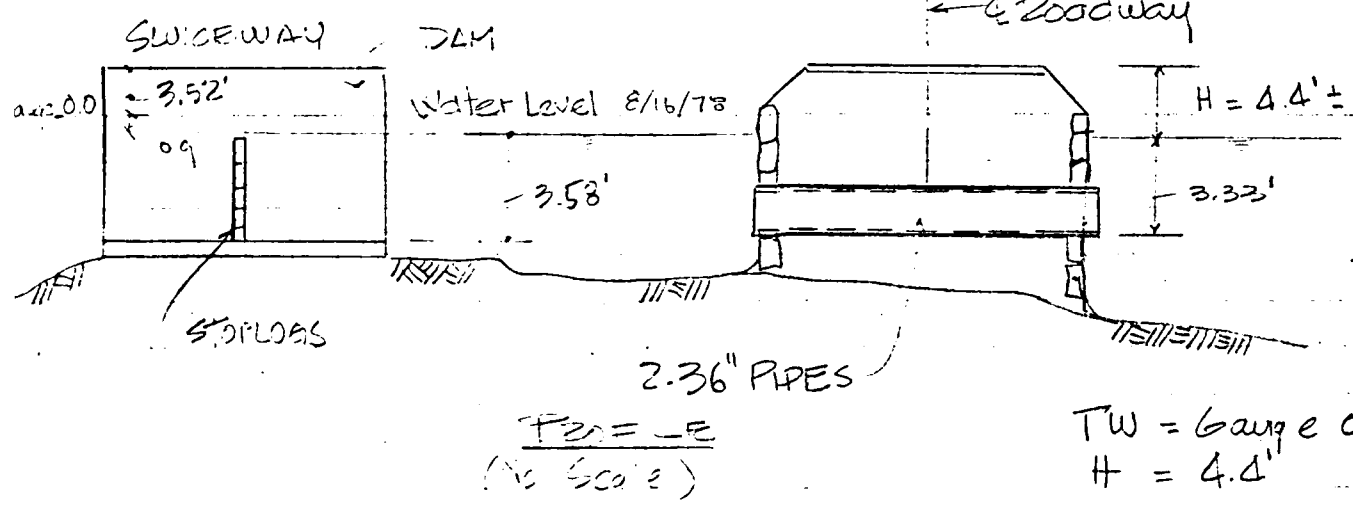

$F_{20} = -E$
(No Scale)

TW = Gauge 0
H = 4.4'

NOTE: The capacity of the two pipes is small compared with the Maximum Probable Flood, therefore, it is assumed the roadway embankment will be overtopped.

The analysis will be concentrated on the dam only.

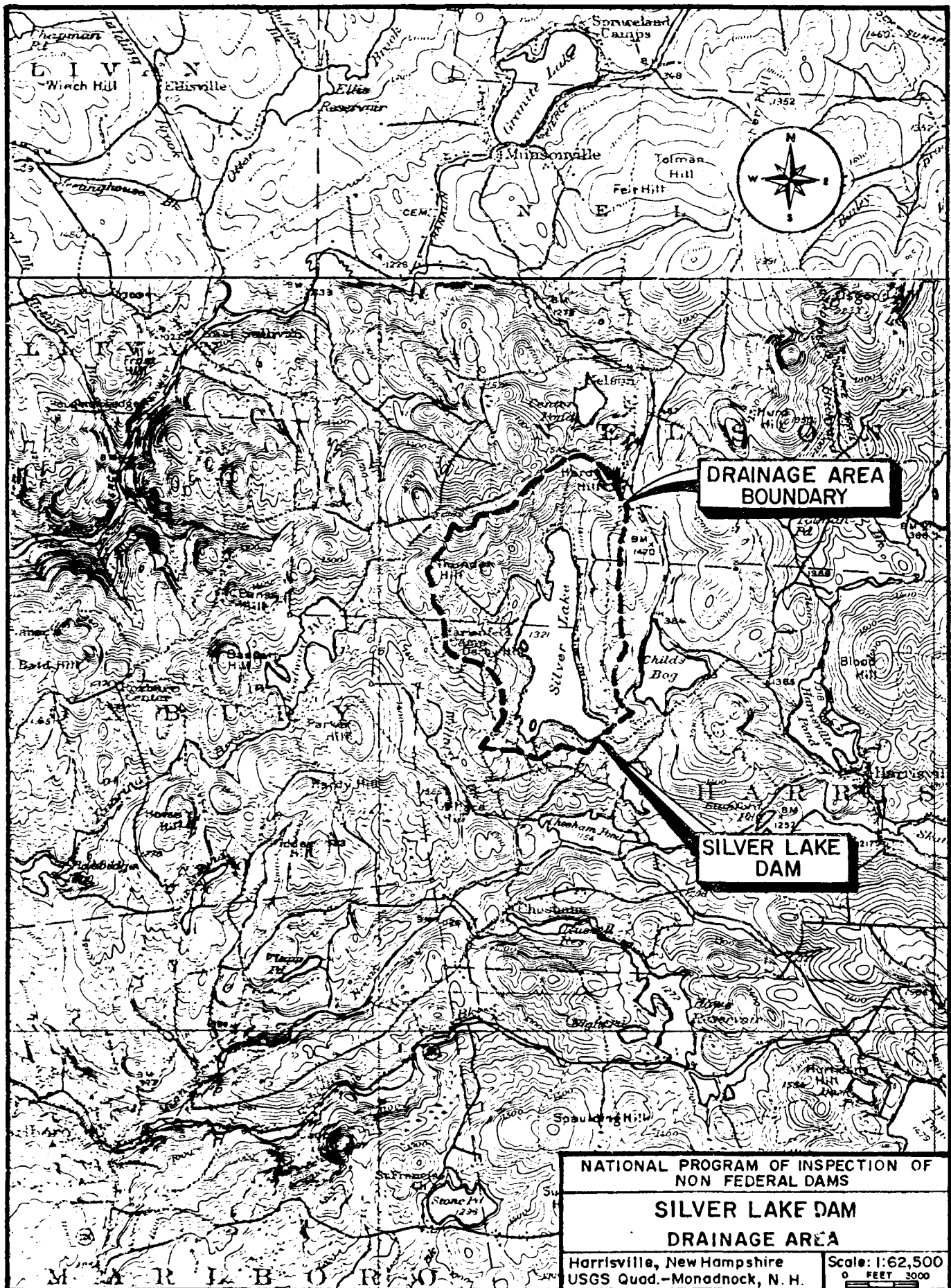

M A R I B O R O

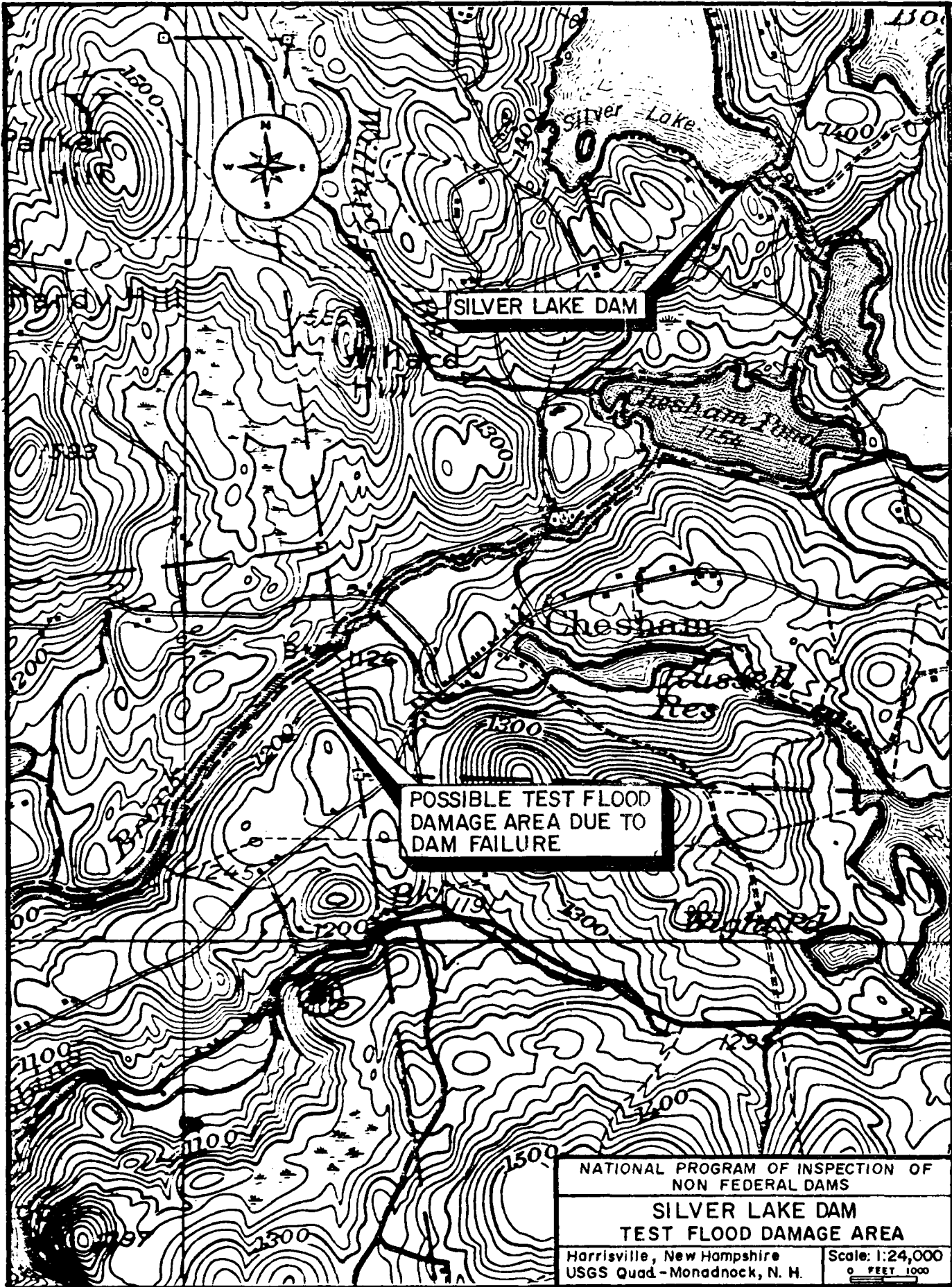

SILVER LAKE DAM

POSSIBLE TEST FLOOD
DAMAGE AREA DUE TO
DAM FAILURE

NATIONAL PROGRAM OF INSPECTION OF
NON FEDERAL DAMS

SILVER LAKE DAM
TEST FLOOD DAMAGE AREA

Harrisville, New Hampshire
USGS Quad - Monadnock, N. H.

Scale: 1:24,000
0 FEET 1000

APPENDIX E

INFORMATION AS CONTAINED IN
THE NATIONAL INVENTORY OF DAMS

END

FILMED

8-85

DTIC