

MICROCOPY RESOLUTION TEST CHART
NATIONAL BUREAU OF STANDARDS 1963-A

AFWAL-TR-84-4044
VOLUME I

AD-A156 652

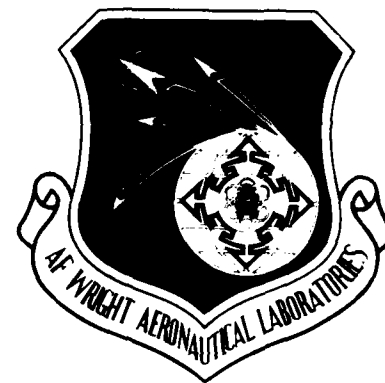

PRODUCT DEFINITION DATA INTERFACE

Final Technical Report

Volume Number I Executive Overview

MCDONNELL DOUGLAS CORPORATION
MCDONNELL AIRCRAFT COMPANY
P.O. BOX 516, ST. LOUIS, MO 63166

APRIL 1984

1 October 1982 - 30 November 1983

DTIC FILE COPY

Approved for Public Release; Distribution Unlimited.

PREPARED FOR:

MATERIALS LABORATORY
AIR FORCE WRIGHT AERONAUTICAL LABORATORIES
AIR FORCE SYSTEMS COMMAND
WRIGHT-PATTERSON AIR FORCE BASE, OHIO 45433

DTIC
ELECTE
S JUL 11 1985 D
G

NOTICES

When Government drawings, specifications, or other data are used for any purpose other than in connection with a definitely related Government procurement operation, the United States Government thereby incurs no responsibility nor any obligation whatsoever; and the fact that the Government may have formulated, furnished, or in any way supplied the said drawings, specifications, or other data, is not to be regarded by implication or otherwise as in any manner licensing the holder or any other person or corporation, or conveying any rights or permission to manufacture, use, or sell any patented invention that may in any way be related thereto.

Note that this document bears the label "FEDD", an acronym for "FOR EARLY DOMESTIC DISSEMINATION". The FEDD label is affixed to documents that may contain information having high commercial potential.

The FEDD concept was developed as a result of the desire to maintain U.S. leadership in world trade markets and encourage a favorable balance of trade. Since the availability of tax supported U.S. technology to foreign business interests could represent an unearned benefit, research results that may have high commercial potential are being distributed to U.S. industry in advance of general release.

The recipient of this report must treat the information it contains according to the conditions of the FEDD label on the front cover.

This technical report has been reviewed and is approved for publication.

Robert A. Carringer
Robert A. Carringer, Lt. USAF
ICAM Project Manager

30 APR 1984
Date

FOR THE COMMANDER:

N.G. Tupper
Nathan G. Tupper
Chief
Computer Integrated Mfg Branch

30 APR 84
Date

"If your address has changed, if you wish to be removed from our mailing list, or if the addressee is no longer employed by your organization, please notify AFWAL/MLTC, Wright-Patterson AFB, Ohio 45433 to help us maintain a current mailing list."

Copies of this report should not be returned unless return is required by security considerations, contractual obligations, or notice on a specific document.

REPORT DOCUMENTATION PAGE		READ INSTRUCTIONS BEFORE COMPLETING FORM
1. REPORT NUMBER AFWAL-TR-84-4044, Volume I	2. GOVT ACCESSION NO. AD-A156652	3. REPORT'S CATALOG NUMBER ETR560130001U
4. TITLE (and Subtitle) PRODUCT DEFINITION DATA INTERFACE Volume I - Executive Overview	5. TYPE OF REPORT & PERIOD COVERED Final 1 Oct. 82 - 30 Nov. 83	
	6. PERFORMING ORG. REPORT NUMBER	
7. AUTHOR(s) R. Dratch K. Gutmann S. Cotter	C. Skinner W. Gruttke	8. CONTRACT OR GRANT NUMBER(s) F33615-82-R-5036
9. PERFORMING ORGANIZATION NAME AND ADDRESS McDonnell Douglas Corporation McDonnell Aircraft Company P. O. Box 516, St. Louis, MO 63166	10. PROGRAM ELEMENT, PROJECT, TASK AREA & WORK UNIT NUMBERS Project Priority 5601	
11. CONTROLLING OFFICE NAME AND ADDRESS Materials Laboratory (AFWAL/MLTC) Air Force Wright Aeronautical Laboratories (AFSC) Wright-Patterson AFB, Ohio 45433	12. REPORT DATE April 1984	
	13. NUMBER OF PAGES 27	
14. MONITORING AGENCY NAME & ADDRESS (if different from Controlling Office) DCASMA, Cleveland DCRO-GCCW 1240 E. 9th Street Cleveland, Ohio 44199	15. SECURITY CLASS. (of this report) Unclassified	
	15a. DECLASSIFICATION/DOWNGRADING SCHEDULE	
16. DISTRIBUTION STATEMENT (of this Report) APPROVED FOR PUBLIC RELEASE; DISTRIBUTION UNLIMITED		
17. DISTRIBUTION STATEMENT (of the abstract entered in Block 20, if different from Report)		
18. SUPPLEMENTARY NOTES		
19. KEY WORDS (Continue on reverse side if necessary and identify by block number) CAD/CAM CAD Integration Exchange Format		
Product Definition Data IGES CAD/CAM Translations		
20. ABSTRACT (Continue on reverse side if necessary and identify by block number) The overall objective of the PDDI project is to develop and demonstrate a computer-driven interface between engineering and manufacturing. This document deals only with Task I and describes the development of a test procedure for evaluating the effectiveness of CAD to CAD part model translations between different vendor systems. In addition to the test procedures, results from field testing of IGES translators for 12 different CAD systems are included.		

FOREWORD

This Final Technical Report covers the work performed under Air Force Contract F33615-82-C-5036, "Product Definition Data Interface, 1 October 1983, through 30 November 1983. The contract is sponsored by the Computer Integrated Manufacturing Branch, Materials Laboratory, Air Force Wright Aeronautical Laboratories, Air Force Systems Command, Wright-Patterson Air Force Base, Ohio, 45433. This program is being administered under the technical direction of Lt. Robert A. Carringer, Project Manager.

McDonnell Aircraft Company (MCAIR) is the prime contractor with Booz, Allen & Hamilton, United Technology Research Center (UTCR), and an Industry Review Board as subcontractors. This program is managed by Mr. Peter J. Downey and Mr. Edwin B. Birchfield. The Booz, Allen & Hamilton Officer-In-Charge is Mr. Charles S. Skinner and the Program Managers are Dr. Ralph Dratch (Task I) and Mr. John McCracken (Task II). Mr. Mark Dunn is the United Technology Research Center Project Manager. Mr. Jim Lardner of John Deere & Company is chairman of the Industry Review Board.

Note: Note that the number and date in the upper right corner of each page of this document indicate that the document has been prepared according to the ICAM Configuration Management Life Cycle Documentation requirements for the Configuration Item.

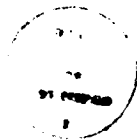

Accession For	
NTIS GRA&I	<input checked="" type="checkbox"/>
DTIC TAB	<input type="checkbox"/>
Unannounced	<input type="checkbox"/>
Justification	
By _____	
Distribution/	
Availability Codes	
Dist	Avail and/or Special
<i>A/</i>	

TABLE OF CONTENTS

<u>Section</u>		<u>Page Number</u>
1.0	Introduction	1-1
1.2	Subject of This Report	1-1
1.3	Test Approach	1-2
1.4	Report Organization	1-2
2.0	The IGES Concept	2-1
3.0	IGES Representation of Engineering Drawings and Part Models	3-1
4.0	Task I Approach	4-1
5.0	Test Methodology	5-1
5.1	Post-Processor Testing	5-1
5.2	Pre-Processor Testing	5-2
6.0	Test Evaluation	6-1
7.0	Test Procedures	7-1
8.0	Summary of Test Results	8-1
9.0	Conclusions and Recommendations	9-1
9.1	IGES Representation of Mechanical Part Data	9-1
9.2	IGES for Exchange of Mechanical Part Data	9-2

LIST OF ILLUSTRATIONS

<u>Figure</u>	<u>Page Number</u>
2-1 The CAD/CAD Interface Problem	2-1
2-2 Communication of Product Definition Data (PDD) Using IGES	2-2
3-1 Geometric Entity Representation of Part Geometry	3-1
4-1 Test Parts	4-2
4-2 Steps to Generate the IGES Test Files	4-4
5-1 Post-Processor Test Steps	5-1
6-1 Pre-Processor Test Steps	6-2
8-1 Successful Translation - 2D Wireframe And Annotation	8-2
8-2 Successful Translation - 3D Wireframe	8-3
8-3 Successful Translation - 3D Wireframe and Surfaces	8-4

LIST OF TABLES

<u>Table</u>		<u>Page Number</u>
1-1	IGES-Evaluation Test Participants	4-1
1-2	Models Developed to Represent the Sample	4-3

1.1 BACKGROUND

With the advent of computer graphics systems, product definition data, including geometric and textual information that was formerly documented with engineering drawings, can be formulated and stored electronically. However, the communication of these data to various manufacturing and control functions, such as process planning, fabrication, assembly, and inspection, is by and large still carried out by transmitting hardcopies of engineering drawings.

The objective of the Product Definition Data Interface (PDDI) Project, sponsored by the Integrated Computer-Aided Manufacturing (ICAM) Program Office of the United States Air Force, is to develop and demonstrate an exchange specification which would allow the replacement of engineering drawings with an electronic interface between engineering and manufacturing functions. The PDDI Project is organized into two tasks:

- Task I - Evaluation and Verification of the Initial Graphics Exchange Specification (IGES).
- Task II - Development and Demonstration of a Product Definition Data Interface.

The Initial Graphics Exchange Specification (IGES) is a format for the digital representation of data needed to define a part or an assembly. It was developed in response to the needs of industry for a solution to the problem of interfacing dissimilar CAD systems. Version 1.0 of IGES has now been incorporated as part of an American National Standard (ANSI Y14.26M-1981). Later versions of IGES are at various stages in the cycle of updating the ANSI Standard.

1.2 SUBJECT OF THIS REPORT

This report is concerned with Task I of the PDDI project and describes the establishment of a test methodology for evaluating the effectiveness of IGES implementations. The work is concerned with three fundamental objectives regarding IGES:

- Establishment of a test methodology and procedures to evaluate IGES translators.
- Determination of the extent to which IGES defines product definition data.
- Evaluation of the level to which the CAD vendor/user community has been able to implement IGES, and the identification of problems in current implementations.

The test methodology established in this project can serve as a baseline from which future test methodologies for subsequent versions of IGES can be developed. In addition, the test results of this effort have served as a valuable source of baseline information for the Task II work.

1.3 TEST APPROACH

The approach taken to address these issues involved field testing of twelve different CAD systems to assess their ability to generate and interpret product definition data in an IGES format. The tests did not exhaustively examine every aspect of IGES but did provide an in-depth evaluation of current 1983 IGES implementations and, as such, identified specific problems encountered with current versions of vendor/user IGES software. In addition, improvements that can be made to the Standard to positively impact translator development and operation were determined. These tests represent the most comprehensive evaluation of IGES performed to date.

1.4 REPORT ORGANIZATON

This report, which is the final report of Task I activities, is organized into three volumes. This volume, Volume I, provides an executive-level summary of the entire Task I effort. Volume II presents the details of the approach to testing, test evaluation, and the findings and recommendations as they apply to the ANSI Standard Y14.26M-1981. Volume III concentrates on the test methodology, and should prove useful to those in the field who wish to perform their own testing. To this end, Volume III discusses the test methodology in a general sense as contrasted with Volume II which addresses the specific results of Task I testing. A set of appendixes to Volume II include examples of some of the more detailed material used during the program.

2.0 THE IGES CONCEPT

IGES activity was initiated by the requirements of industry for a near-term solution to the needs of interfacing current graphics systems. The Air Force ICAM program, other DoD agencies such as the Army, Navy, and NASA, and the NBS have served as a catalyst in establishing the IGES concept. The need for a near-term solution was precipitated by organizations that had purchased systems from different vendors, and organizations that understood the advantage of direct digital-data exchange with suppliers and subcontractors.

The problem is that each CAD vendor typically has a unique and proprietary "native" format for the representation of data necessary to define a product. In order to make use of information generated by one CAD system (A) on a second CAD system (B), a translator must be developed to go from A's native format to B's native format, and a second translator developed to go from B's format back to A's. This problem grows quickly as more CAD systems are added - six translators are required for three different CAD systems as shown in Figure 2-1 below.

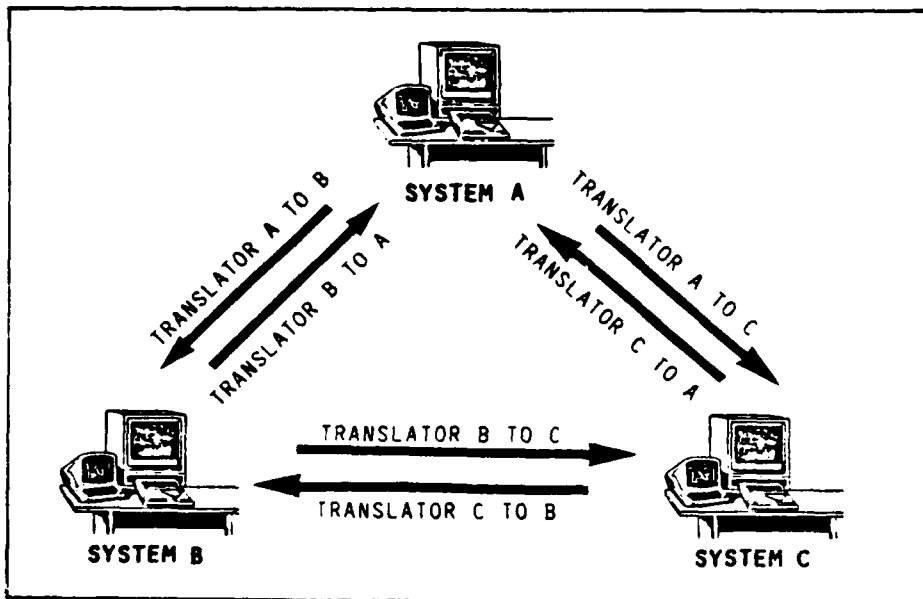

Figure 2-1 The CAD/CAD Interface Problem

As a way of circumventing this customized translator development problem, IGES defines a "neutral" data file as a means of linking dissimilar systems as depicted in Figure 2-2.

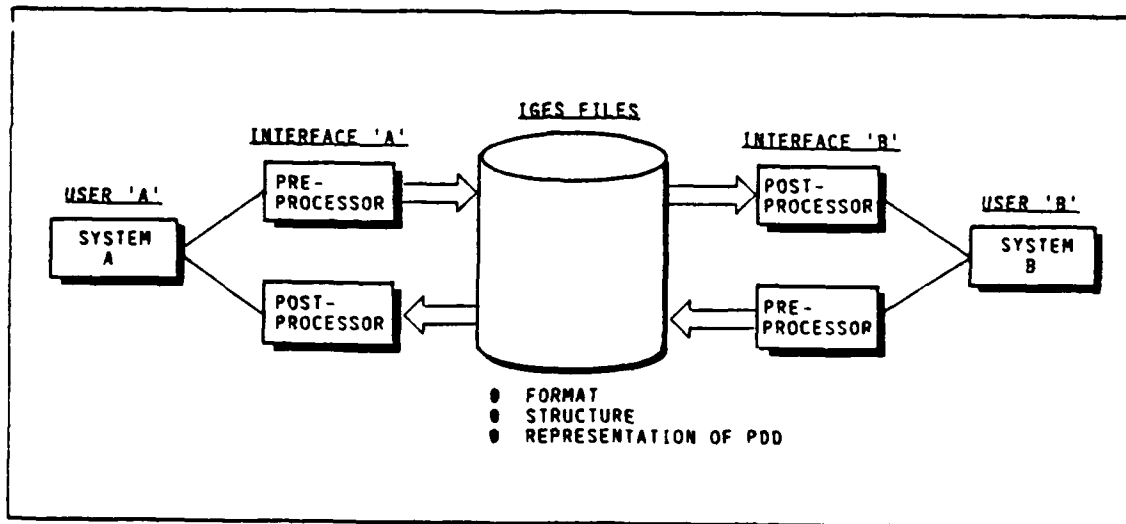

Figure 2-2 Communication of Product Definition Data (PDD) Using IGES

The sending system produces a data file in IGES format which is then transferred to and read by the receiving system. This is accomplished by using a computer program, called an IGES pre-processor, which translates the product definition from the original format into IGES format. Similarly, IGES post-processor software automatically translates product definition data in IGES format into the format used by the receiving system. These pre-and post-processor software programs are system dependent and are supplied by the CAD system vendor or, in some cases, developed by the system user.

An assessment of IGES, therefore, also entails an assessment of the level of vendor, user, and third party development of IGES preand post-processor software. An evaluation of processor implementations together with an analysis of the IGES Standard, as performed during Task I, provided an overall evaluation of IGES.

IGES is based on the engineering drawing representation of product definition data with Version 1.0 specifically oriented to mechanical applications. At this point in time, IGES Version 2.0 has been released by the National Bureau of Standards (NBS) and work on Version 3 is ongoing by the NBS-managed IGES committees.

The procedures by which IGES is adopted as an ANSI standard, however, require a certain amount of time lag between the release of an IGES version and the publication of the corresponding ANSI documentation. Thus, although IGES is continuously evolving, the ANSI Standard, which is the focus of attention of Task I work, is defined by IGES Version 1.0. The test procedures, therefore, were specifically applied to test those features of IGES defined in Version 1.0. In those cases where later IGES versions correct errors or more clearly describe concepts, these later interpretations have been used.

Three attributes of the product definition data file are specified by IGES:

- File format
- File structure
- Representation of individual elements
 - geometry
 - annotation
 - relationships

IGES Version 1.0 files are in ASCII format with 80 characters/record. The fundamental unit of information in IGES is the entity. IGES defines entities to represent geometric elements, such as points, curves and surfaces, annotation, and other elements that enhance product descriptions, such as subfigures, groups and views. Thus, an IGES file is a collection of entity descriptions.

3.0 IGES REPRESENTATION OF ENGINEERING DRAWINGS AND PART MODELS

Information contained on an engineering drawing can be separated into three categories:

- Geometric information required to define the part.
- Fabrication information required to produce the part including tooling and inspection.
- Assembly information required to show the relationship of a part to a subassembly or final product.

Two-dimensional geometry is represented in IGES by simple geometric entities such as lines, arcs, conics, and parametric cubic splines as shown in Figure 3-1.

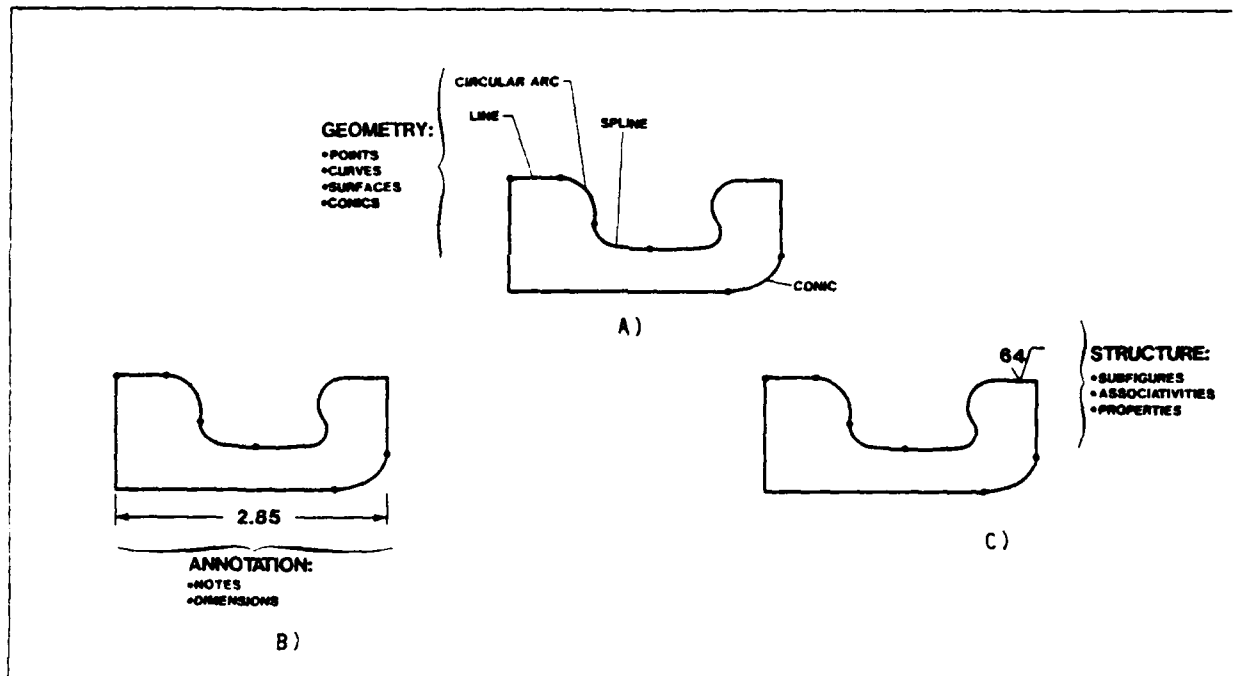

Figure 3-1 Geometric Entity Representation of Part Geometry

Three-dimensional models can be represented using the IGES surface entities such as the ruled surface, tabulated cylinder, and parametric cubic patch, as well as line and curve entities. Solid modeling is not supported in either Version 1.0 or 2.0. Part features, such as flanges, holes, and webs, are not represented as specific entities but rather as collections of these basic geometric curve and surface elements.

The majority of IGES annotation is built from three basic entities - text (general notes), leaders, and witness lines. Annotative features are represented by IGES as combinations of these basic entities. For example, a linear dimension entity is made up of a general note, two leaders, and zero to two witness lines.

IGES structure entities provide several mechanisms to extend the capabilities of the pre-defined entity set and to add meaning to an IGES entity by specifying relationships and attributes. These structure entities include the subfigure, associativity, property and MACRO entities. Additional details of the IGES file structure and entity definitions can be found in ANSI Y14.26M-1981, and Volume II of this report.

4.0 TASK I APPROACH

The principal means used to provide an assessment of IGES was through a series of field tests. Twelve CAD systems equipped with IGES translators were tested at either user or vendor sites by applying the test procedures developed during the project. The test procedures, which are discussed in the next section, address the overall problem of evaluating product definition data converted from a CAD-vendor-specific format to an IGES representation (pre-processing), and from IGES back into a specific CAD format (post-processing). Vendors and users included in the field testing are listed in Table 1 below.

Field testing was based on the ability of actual CAD systems to translate product definition data that are represented in IGES data files. In order to create these files, three tasks were required:

- Selection of sample parts
- Generation of engineering drawings
- Development of IGES files.

The first step involved the selection of parts to be modeled. Four sample aerospace-type parts were selected for use during testing. Each part may be generally classified into one of four categories - sheet metal, turned, composite, and machined. Parts selected for testing represent simplified versions of actual production parts. Simplifications of redundant part features were made to reduce the number of entities to a manageable level for testing yet still provide meaningful test data. Since IGES is primarily based on a set of discrete elements, or entities, as described in the previous section, little has been lost through these simplifications.

Table 1-1 IGES-Evaluation Test Participants

<u>Vendors</u>	<u>Users</u>
● Applicon	● Boeing-CIIN
● CDC-CD2000	● Ford-PDGS
● Calma	● McDonnell Douglas-CADD
● Computervision-CADDS4X	
● Gerber	
● Intergraph	
● IBM-CADAM	
● McAuto-UNIGRAPHICS	
● MCS-ANVIL 4000	

Figure 4-1 shows the four parts selected for testing. The upper portion of the figure shows the sheet metal and machined parts from the leading-edge extension of the F-18 aircraft manufacturing by McDonnell Douglas. The composite part is from the wing trailing-edge flap structure of an F-18. The turned part is a truncated version of a part used in the CAM-I Geometric Modeling Project.

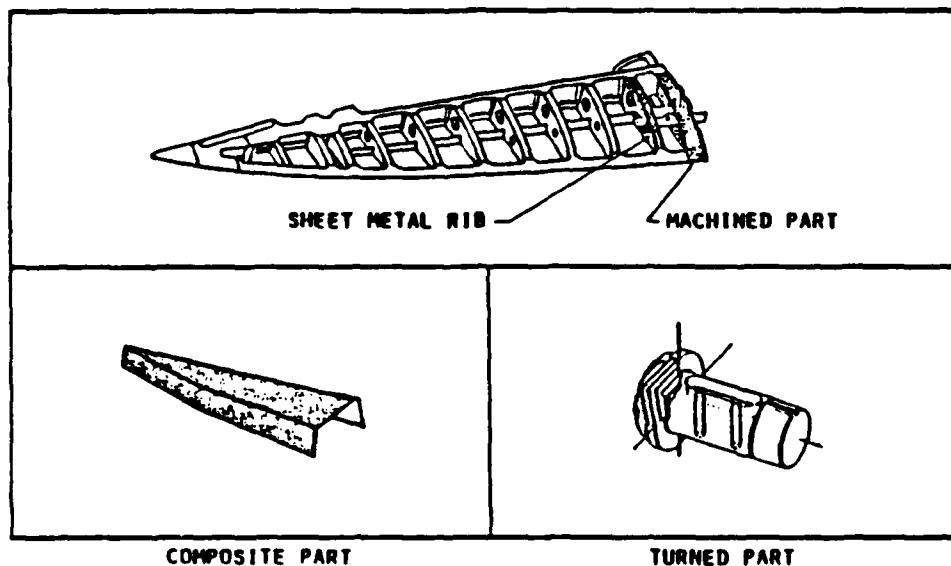

Figure 4-1 Test Parts

Blueprints of engineering-release quality were created for the four parts on the McDonnell Douglas CADD system. These prints were then reviewed by Booz, Allen design engineers and manufacturing personnel representing several aerospace companies to comment on company-specific practices that may have been present. Suggested changes were included in the final part drawings.

The last step involved the actual development of the test files, where the blueprints representing the four parts were turned into CAD models. Before a part was coded into IGES format, it was necessary to determine exactly what should be included in the test file. Ideally, one would include the entire part with all associated views and annotations. However, the resultant IGES file would contain hundreds, or even thousands of instances of a few commonly used entities such as lines, arcs, leaders and notes, and may not contain all types of entities IGES is capable of supporting. Such a file would not provide a comprehensive test of IGES implementation. To ensure that the test files exercised the full range of IGES capabilities, features were selectively added to the sample parts to incorporate those IGES entities not already included.

Another item that must be considered is the model representation to be used to describe the part. Currently IGES is capable of portraying CAD models that are either 2D, 3D wireframe, or 3D wireframe with surfaces. Following the normal engineering convention, 2D models were developed for the sheet metal and composite parts while 2D and 3D models were developed for the turned and machined parts. The composite part was developed as two separate models since the flat pattern is treated as a separate drawing by manufacturing. In total, seven part models were created. Table 1-2 shows the types of representations developed from the four parts.

Table 1-2 Models Developed To Represent The Sample

Part Name	2D	3D Wireframe	3D Wireframe And Surface
Sheet Metal	X		
Turned	X		X
Composite	X(Rib), X(Flat)		
Machined	X	X	

In order to generate the IGES test files efficiently and with few errors, the actual coding of the files utilized a combination of manual and computer translation. The parts were first modeled on the McDonnell Douglas CADD design system. The sample part representations were then transferred from CADD to UNIGRAPHICS using a CADD-to-UNIGRAPHICS software interface.

The next step was the creation of the IGES files from the UNIGRAPHICS CAD system. An IGES pre-processor from the McAuto UNIGRAPHICS CAD system was used to generate the majority of simple wireframe part geometry. After pre-processing, the files were manually checked to verify the validity of the data. Manual changes were made to the files where discrepancies occurred. Annotation, three-dimensional surfaces, and other advanced structural entities were hand generated and added to the files. The hand generation was based on IGES Version 1.0 with Version 2.0 used to provide clarification. Figure 4-2 below presents a flowchart of the steps involved in the generation of IGES test files.

A working group of key members from the IGES community was formed to help in the selection of choices among alternate representations for certain features, and to answer questions on interpretation of the IGES specification. The working group consisted of Bradford M. Smith, chairman of the IGES Committee, Philip R. Kennicott, chairman of the Extensions and Repair subcommittee, and Michael Liewald, the chairmen of the Test, Evaluate and Support subcommittee.

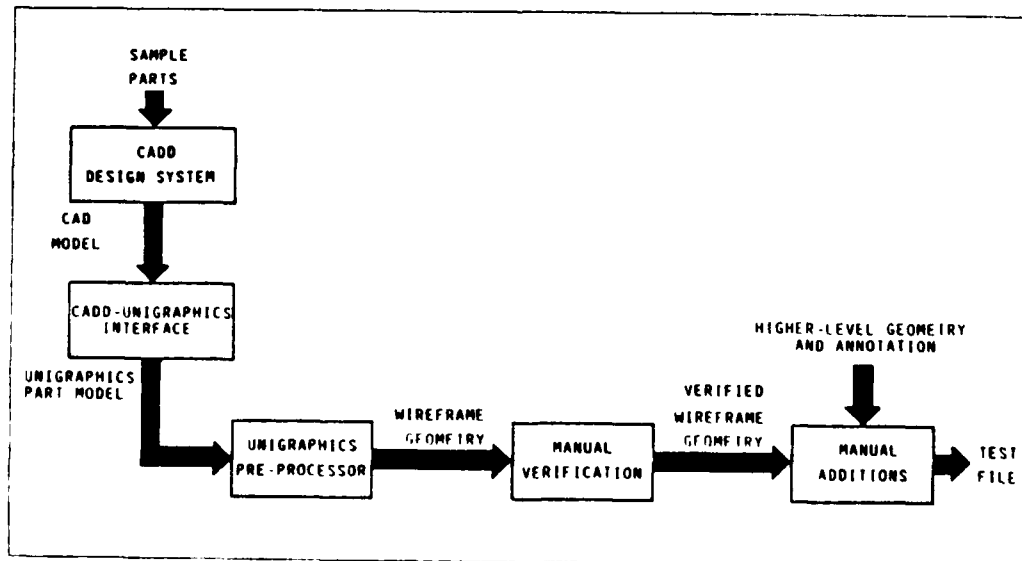

Figure 4-2 Steps To Generate The IGES Test Files

5.0 TEST METHODOLOGY

This section presents a summary of the test methodology that was developed for evaluating IGES translators and applied in actual field testing. Since IGES pre-and post-processors are separate software packages and perform different functions, the test methodology treats them independently. Specific details of the methodology are discussed in Volumes II and III of this report.

5.1 Post-Processor Testing

The first test step, as shown in Figure 5-1, involved the post-processing of the seven IGES test files discussed in the previous section. These files were recorded on magnetic tape and were translated on the test participant's CAD system. The resultant part models were brought up at the CAD station and displayed. Standard reference lengths were selected to ensure that correct scale was maintained during translation. A plot of the part was made to record the results of test file translations. Plots were used for comparison with master Mylars that depicted the correct representation. The part was then rotated, scaled, and viewed normal to different planes to check for any annotation or geometry that may not have been in the correct location, or that could not be seen in a standard view. The part was checked for correct end-point conditions of entities by either using a chain-select feature or an NC model validation routine. This portion of the test checked to see if a model was connected from one entity to another. Entities that are properly connected should share the same mathematical endpoints.

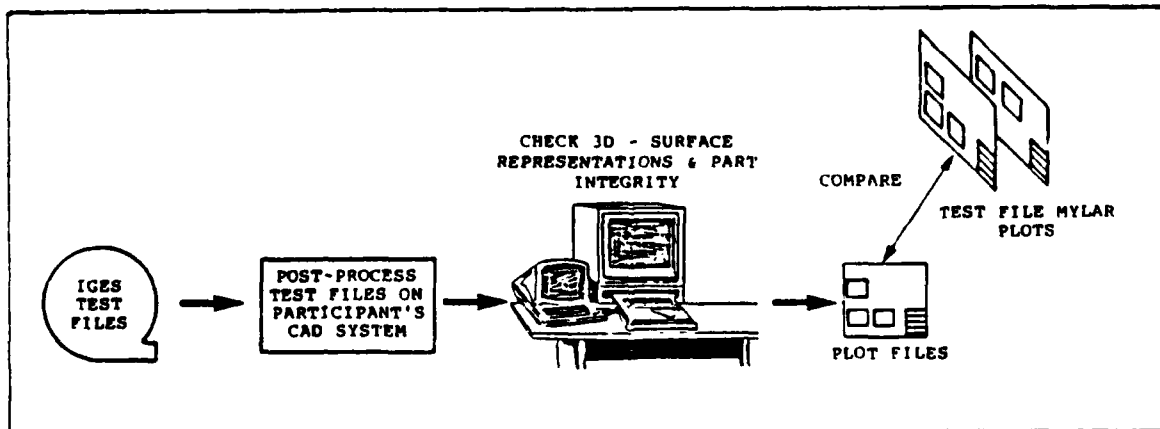

Figure 5-1 Post-Processor Test Steps

The next step in the test involved a functional check of the translated model. Functionality is defined as the ability of the CAD system to handle parts as if they were created on the system being tested. Each piece of annotation was selected to determine its entity type after translation. Text was then edited and moved using functions that were normally supported by the CAD system being tested. The last functionality test involved the selection of entities that were coded as group associativities in the IGES files. One member from the group was selected and if the translation was performed correctly, the remaining group members were automatically selected.

Surfaces forming the 3D turned part were checked for accuracy by determining the intersection of lines with the surface. Predetermined lines that intersected the surfaces were entered by the CAD operator. The operator then found the intersection of the lines with the surface using a CAD system command. Intersection points were compared with the calculated points.

The last step involved a comparison of the system generated plots with the master Mylars. Geometric inaccuracies were identified, as well as problems associated with annotation, such as misplaced leaders, text size, or text placement.

5.2 Pre-Processor Testing

Pre-processor evaluation began with the input of part representation data into the participant's CAD system. Entry of part representations was accomplished through a variety of means. Some part representations were entered into the CAD system by a designer using the engineering drawings of the parts for reference. In this manner, the part representations were created in the natural working mode of the designer. As this input method does not introduce any test-related biases, it was preferred, however, it was also time-consuming. The majority of the part representations, therefore, were input with the aid of IGES-formatted data files.

After the part representations were entered, a hardcopy of the parts, as they graphically appeared on the participant's CAD system, was obtained as a record of the representations existing in the CAD system. The files were then pre-processed and copies of the pre-processed IGES files were made on magnetic tape. This tape was used during the subsequent pre-processor evaluation.

Evaluation of pre-processed translations was accomplished by using a combination of three methods (Figure 6-1). The first method involved a "full-circle" test of the IGES translators. This test was designed to examine how well a participant could handle pre-processed files that were "self" generated. The pre-processed files were post-processed on the same system and manipulated to ensure part functionality. Hard-copies of the post-processed part representations were obtained and compared with the original part drawings. Checking of 3D surfaces was accomplished by determining the intersection of vertical lines with the surface.

The second pre-processor evaluation method was based on the use of a "jury system". For Task I the jury was composed of two CAD systems that exhibited a high level of implementation and/or translation capabilities during post-processor testing - were selected. Pre-processed files obtained from the test participants were post-processed on a UNIGRAPHICS and a General Electric-Schenectady developed IGES translator, and evaluated for completeness and correctness of translation using the same procedures discussed for the "full-circle" test.

The third method used in the evaluation of pre-processed files was hand checking of the IGES code. Hand checking involved comparison of the parameter data in a participant's file with the parameter data of part features in the standard IGES test file. In order to simplify this comparison, the pre-processed files were run through a utility program (developed at McDonnell Douglas Automation) to sort entities, and standardize formats and transformations in order to reduce the complexity of manually interpreting the IGES files. A sample of such a sort is presented in Appendix D of Volume II.

Major inconsistencies discovered through the first two evaluation methods were analyzed by manually checking entities in the subject's IGES file. In addition, parameters and formats of other selected entities were spot checked to ensure correct translation.

6.0 TEST EVALUATION

Test results from the twelve test participants were evaluated on the basis of the accuracy and functionality of processed data. Accuracy is a measure of the exactness of the processed data with respect to the original material. Functionality refers to the ability of the receiving system to handle the test data as if they were created in the native environment.

As this evaluation was based on the ability of CAD systems to exchange information via IGES, accuracy and functionality have been defined with respect to the CAD environment. In order to evaluate the utility of IGES to link engineering information with manufacturing functions, a thorough understanding of the information requirements of manufacturing needs to be developed. This understanding is one of the primary outputs of Task II of the PDDI project. Although Task I test procedures did not explicitly evaluate the ability of IGES to function as this link, the test results, coupled with an understanding of manufacturing requirements from Task II, provided an indication as to the utility of IGES for future linkage implementations.

Specific criteria used to perform the evaluation were:

- Completeness - the degree to which all part data appear in a display of the processed information.
- Legibility - the degree to which the display can be unambiguously interpreted.
- Geometric Accuracy - the degree to which geometric parameters, such as dimensions, shapes, and intersections, are properly represented.
- Functionality - the degree to which processed part data are treated as if they were generated on the system being tested.
- Attributes - the degree to which entity attributes are correctly handled by the test system.
- Associativity - the degree to which associations among entities are maintained.

These criteria were applied on an entity-by-entity basis to identify specific problems with individual translators.

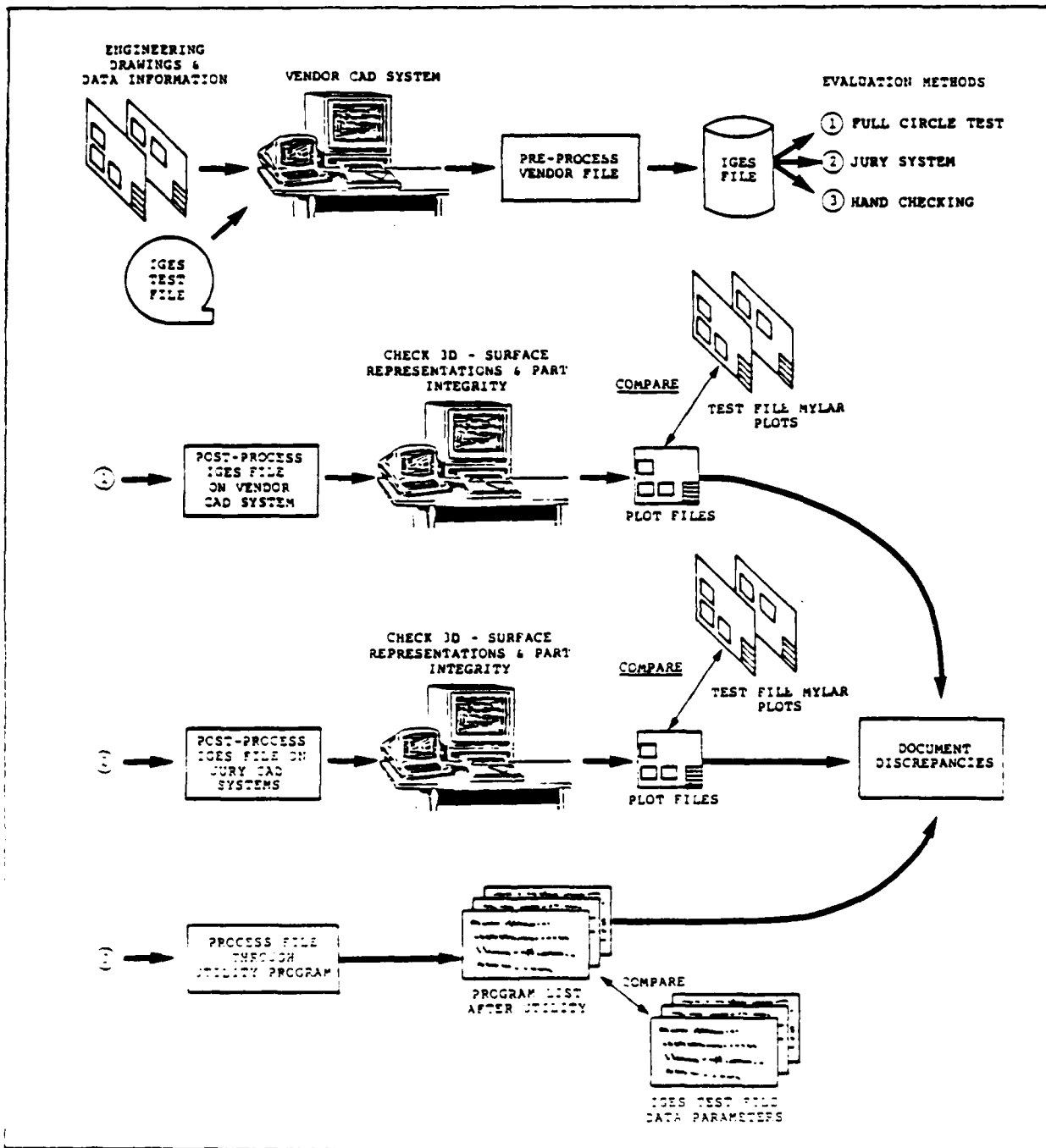

Figure 6-1 Pre-Processor Test Steps

FTR560130001U
1 February 1984

7.0 TEST PROCEDURES

It is the intention of the ICAM Office (Wright-Patterson Air Force Base, Dayton, Ohio) to make these the procedures and test files used in performing IGES evaluations available through the National Bureau of Standards. This material may be used to test purchased IGES translators, and may also be helpful in "debugging" evolving translators during the development effort. Information concerning acquisition and use of these test materials can be obtained from Mr. Bradford M. Smith of the National Bureau of Standards.

8.0 SUMMARY OF TEST RESULTS

Overall, Task I test results showed that no participant has implemented a complete IGES Version 1.0 preand post-processor. Wireframe geometry and annotation have been implemented widely while surfaces and structure are minimally implemented.

Of the wireframe geometry, points, lines, and circular arcs were successfully translated, while conic arcs and parametric splines presented problems at many of the sites. Less than half the participants tested had implemented surfaces and, of those, only half were successful. Only one participant has implemented the more complex parametric spline surface. Annotation has been widely implemented, however, many problems were encountered with the graphical and functional translation of annotation. Structure entities have a very low level of implementation. Most of the participants dealt successfully with the IGES format, but there was considerable confusion on the use and interpretation of the global parameters.

Although the detailed results presented in Volume II of this report focused on translation problems, most Task I test participants were generally successful in translating the test cases as shown by the examples in Figures 8-1, 8-2, and 8-3. Many of the problems found during testing were site-specific, and should be addressed by individual participants. However, several IGES-related problems have been identified in Volume II of this report, and warrant further work by the IGES community.

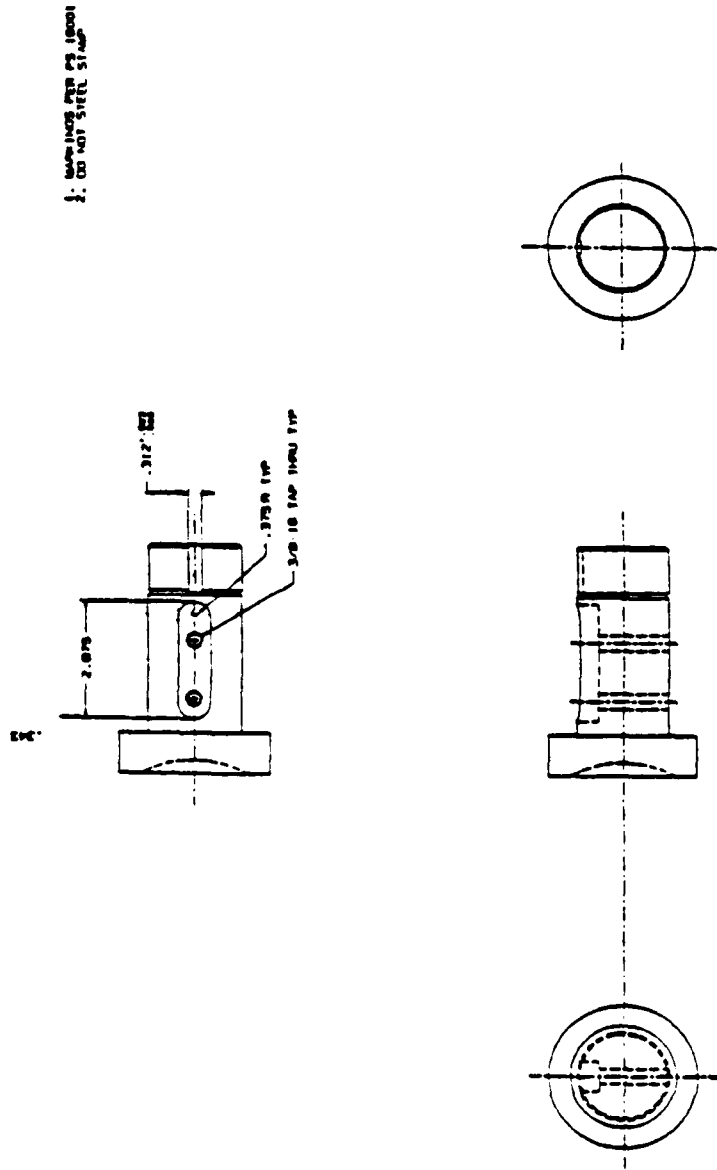

Figure 8-1
Successful Translation - 2D Wireframe and Annotation

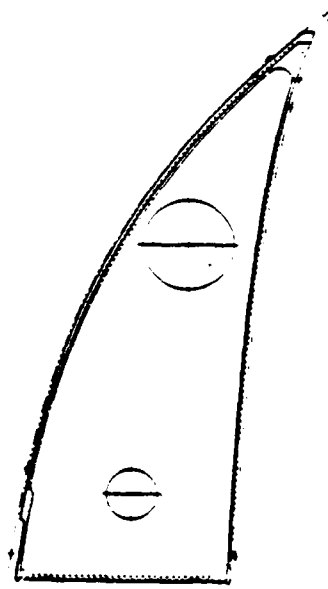
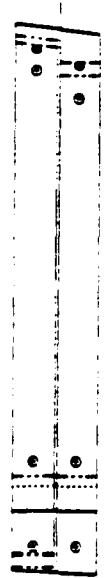
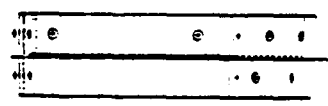
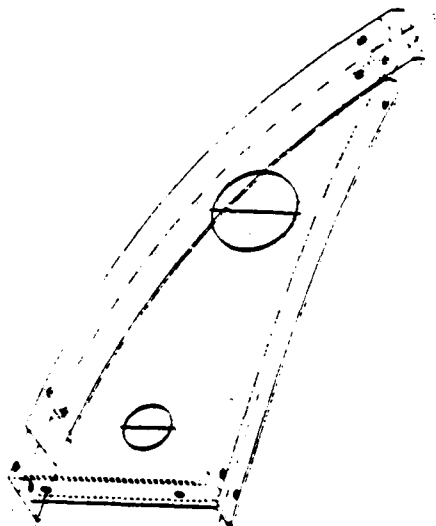

Figure 8-2
Successful Translation - 3D Wireframe

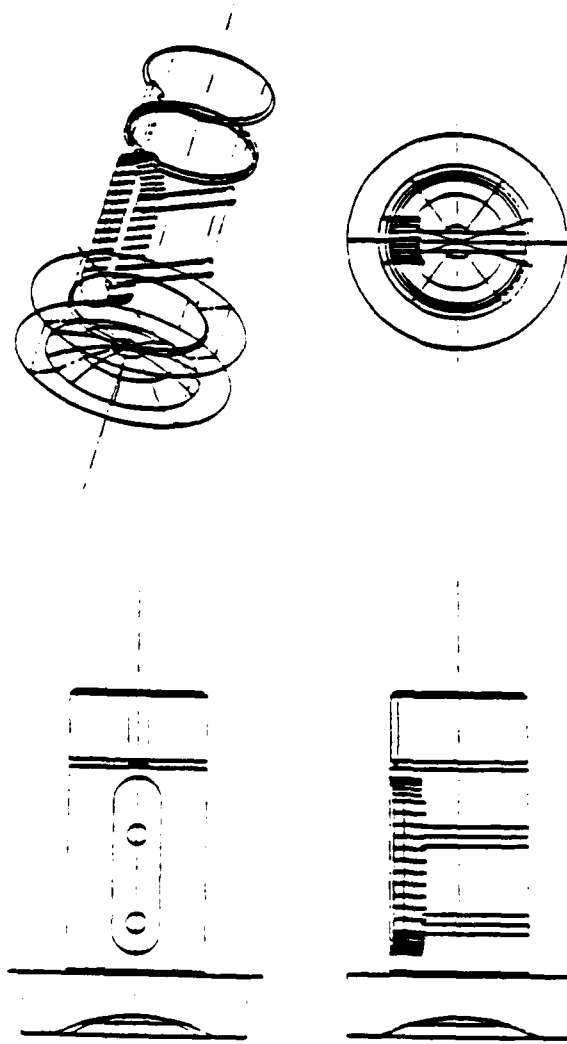

Figure 8-3
Successful Translation - 3D Wireframe and Surfaces

9.0 CONCLUSIONS AND RECOMMENDATIONS

Overall, the Task I program has shown that IGES can transfer information currently used to represent CAD models of mechanical parts, and that there is widespread support for IGES within the CAD vendor/user community. Based on its success in dealing with CAD-to-CAD information exchange as investigated in Task I, IGES should be considered as an alternative for the PDDI exchange format to be developed in Task II. However, there are numerous problems with IGES that are impeding the progress of its implementation. These problems must be addressed and resolved before manufacturing extensions to IGES are considered.

9.1 IGES REPRESENTATION OF MECHANICAL PART DATA

Overall, the ability of IGES to represent CAD models of mechanical parts is very good. The flexibility available in the Standard allows an implementor to choose the representation most appropriate to the needs of the specific CAD system. In addition, an implementor can develop user-defined entities tailor-made for his or her requirements.

IGES geometry addresses most of the needs of current CAD systems. The primary problem is in the advanced spline curve and spline surface representations. Some spline and surface types cannot be exactly represented by the IGES parametric cubic curve and parametric spline surface. In addition, IGES has no explicit representation of offset curve characteristics needed by current CAD systems. This could be incorporated using IGES structure capabilities.

Although IGES annotation entities can graphically represent most of the annotation found in engineering blueprints, they do not adequately address the functional requirements of current CAD annotation. That is, the CAD system cannot extract enough information from the IGES annotation entities to reconstruct internal representations. If the annotation is non-functional, the graphical picture of the annotation may look correct but an operator will not be able to move, edit or automatically redimension if part geometry is altered.

All of the identified problem areas for annotation can be addressed by using the flexible IGES structure capabilities. However, common needs among CAD vendors and users for annotation enhancements would be more efficiently addressed by changes or additions to the annotation entities themselves.

9.2 IGES FOR EXCHANGE OF MECHANICAL PART DATA

The utility of IGES for the exchange of mechanical part data was determined by the level of IGES processor development within the CAD vendor/user community, and the success of those processors in translating mechanical part data.

Current implementations of IGES pre- and post-processors primarily translate wireframe geometry and annotation. There is moderate implementation of surfaces and minimal implementation of structure, such as subfigures, associativities, properties and MACROS. There is substantial support for IGES within the vendor and user communities, and it is widely recognized as an exchange standard. However, there are numerous problems that have been identified in these implementations and within the Standard itself, as detailed in Volume II of this report.

IGES processor implementation problems encompass both implementation errors and processing practices that are not explicitly addressed by the IGES Standard but can affect translator effectiveness. Implementation errors are site-specific and must be resolved by the translator developer. One common area of implementation errors, however, is in the translation of curve and surface geometry. Personnel who develop IGES software quite often do not have the in-depth mathematical background necessary to implement accurate and efficient geometry translation. In addition, no guide or recommendation exists to aid in implementation and to provide a consistent mathematical approach to translation. Such a guide would help reduce geometry translation problems, particularly for spline curves and surfaces.

As in virtually any attempt to interface dissimilar systems with a specified format, the IGES approach is not truly "neutral." IGES is based on first-generation commercial CAD systems representation of geometry and annotation. Annotation, in particular, needs to be enhanced to address current CAD annotation functionality. In addition, systems that differ significantly from the IGES representation of information have more difficulty in processing some IGES entities. As the industry evolves, more vendors may be adopting different representations, which may intensify this problem.

IGES provides a capability for the representation of part models that may be too flexible. Although some flexibility is necessary when mapping among dissimilar systems, the flexibility in IGES can lead to a loss of information upon translation. Substantial post-processor interpretation is then required and inconsistent interpretation can result. User-defined entities can extend the IGES representation capabilities, but implementors of pre- and post-processors must agree on the form and function of these entities in order to interpret them.

* * * * *

In summary, Task I testing and analysis resulted in the following major conclusions:

- IGES is a workable approach for exchanging product definition data in a CAD-to-CAD environment and has the potential as a basis for the PDDI exchange format.
- As it has grown to serve a wide variety of users, IGES has become too flexible in its ability to represent product data, resulting in confusion and the potential for loss of data.
- Version 1.0, and, in many cases, Version 2.0 contain numerous instances of ambiguous definitions or omissions which when corrected will facilitate processor development and use.
- Current implementations are most successful when dealing with simple 2D and 3D wireframe geometry, and are less successful with splines, surfaces, and annotation.
- Documentation to aid in translator development and use requires improvement.
- Users and vendors have a generally positive attitude concerning IGES translator development and application.

These conclusions have been conveyed to the IGES community for appropriate action.

END

FILMED

8-85

DTIC