

HARDMAN

Comparability Analysis Methodology Guide

AD-A156 788

Volume II Problem Definition Step 1 - Systems Analysis

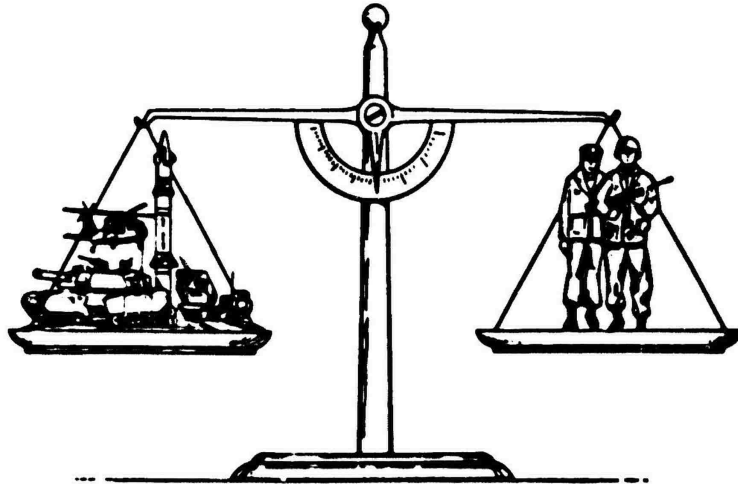

HARDware vs. MANpower

April 1985

DTIC FILE COPY

DTIC
ELECTE
JUL 24 1985



US Army
Research Institute



Soldier Support Center-
National Capitol Region

85 7 24 084

REPORT DOCUMENTATION PAGE		READ INSTRUCTIONS BEFORE COMPLETING FORM
1. REPORT NUMBER Research Product 85-19 Thru 85-23	2. GOVT ACCESSION NO. AD-A156788	3. RECIPIENT'S CATALOG NUMBER
4. TITLE (and Subtitle) HARDMAN Comparability Analysis Methodology Guide (5 Volumes)		5. TYPE OF REPORT & PERIOD COVERED Final
7. AUTHOR(s) Thomas E. Mannle, Jr. Robert V. Guptill Daniel T. Risser		6. PERFORMING ORG. REPORT NUMBER
9. PERFORMING ORGANIZATION NAME AND ADDRESS Dynamics Research Corporation 60 Concord Street Wilmington, MA. 01887		8. CONTRACT OR GRANT NUMBER(s) MDA903-81-C-0561
11. CONTROLLING OFFICE NAME AND ADDRESS U.S. Army Research Institute 5001 Eisenhower Avenue Alexandria, VA 22333		10. PROGRAM ELEMENT, PROJECT, TASK AREA & WORK UNIT NUMBERS 2Q263731A793
14. MONITORING AGENCY NAME & ADDRESS (if different from Controlling Office) U.S. Army Soldier Support Center-National Capitol Region 200 Stovall Street Alexandria, VA 22332		12. REPORT DATE April 1985
		13. NUMBER OF PAGES 1077
16. DISTRIBUTION STATEMENT (of this Report)		15. SECURITY CLASS. (of this report) Unclassified
17. DISTRIBUTION STATEMENT (of the abstract entered in Block 20, if different from Report)		15a. DECLASSIFICATION/DOWNGRADING SCHEDULE Unannounced Justification: Distribution/Availability Codes Dist Special A-1
18. SUPPLEMENTARY NOTES 5 Volumes-Volume I-Manager's Guide; Volume II-Problem Definition, Step 1-Systems Analysis; Volume III-Requirements Analysis, Step 2-Manpower Requirements Analysis, Step 3-Training Resource Requirements Analysis, Step 4-Personnel Requirements Analysis; Volume IV-Interpretation and Evaluation, Step 5-Impact Analysis, Step 6-Tradeoff Analysis; Volume V-Analysis Support Information		
19. KEY WORDS (Continue on reverse side if necessary and identify by block number) Alternatives and Tradeoff Analysis Manpower Cost and Readiness Drivers Comparative Analysis Manpower Support Inputs Functional Requirements Identification Support System Standardization Human Resources in LCSMM Task Description Logistics Analysis Training Requirements Estimation		
20. ABSTRACT (Continue on reverse side if necessary and identify by block number) This is the first edition of the Army HARDMAN Comparability Analysis Methodology Guide. The five volumes constitute a detailed specification of the methodology as applied to major materiel systems. HARDMAN is a structured approach to the determination of the Manpower, Personnel and Training (MPT) requirements of a weapon system in the earliest phases of its development. The basic analytic approach is comparability analysis, that is, the use of knowledge about similar existing systems to project the MPT requirements of proposed (new) systems. The		

Unclassified

SECURITY CLASSIFICATION OF THIS PAGE(When Data Entered)

Block 20 -

1
Army HARDMAN Methodology Guide attempts to satisfy the requirements of the Army by 1) providing details of analytic procedures to a level which permits analysts to execute the HARDMAN Methodology in an actual operational environment, 2) providing a stand-alone guide with maximum flexibility to appeal to different types of users, 3) incorporating field-tested procedures which have proven to reflect actual MPT costs, 4) incorporating lessons learned with the Army data environment to reflect the real constraints in that area and 5) contributing to the Logistics Support analysis performed in accordance with MIL-STD-1388-1A (Logistics Support Analysis Data Element Definitions).

Unclassified

SECURITY CLASSIFICATION OF THIS PAGE(When Data Entered)

FOREWORD

This is the first edition of the Army HARDMAN Comparability Analysis Methodology Guide. It was compiled jointly under the auspices of the Army Research Institute (ARI) and the Soldier Support Center-National Capital Region (SSC-NCR).

The five volumes constitute a detailed specification of the Army HARDMAN Methodology as applied to major materiel systems. The Guide is intended to provide the Army with a basis for competitive HARDMAN contracting, conducting "in-house" Army HARDMAN applications, and providing HARDMAN training for Army personnel. In the future, many of you may become involved in the process and/or with the products of an Army HARDMAN Analysis. These volumes have been provided as an aid to your understanding of this analytical tool.

It should be noted that the HARDMAN procedures described herein are not expected to remain forever unchanged. Rather, it is desired that HARDMAN evolve over time to better meet the Army's changing information needs on newly emerging systems. You are invited to participate in this evolutionary process by providing your comments on, and recommended improvements to, the Methodology. Such comments concerning the Army HARDMAN Guide or the Army HARDMAN Methodology should be mailed to:

Commander
Soldier Support Center-National Capital
Region
ATTN: ATZI-NMS
200 Stovall St.
Alexandria, VA 22332-0400

Additional copies of the HARDMAN Comparability Analysis Methodology Guide will be available through the Defense Technical Information Center (DTIC) in the near future.

Table of Contents

	<u>Page</u>
Step 1 Systems Analysis	1-1
Substep Group 1A Mission Analysis	1A-1
Substep 1.1 Identify General Mission Requirements	1A-5
Substep 1.2 Identify Detailed Mission Requirements	1A-13
Substep Group 1B Functional Requirements Analysis	1B-1
Substep 1.3 Determine Functional Requirements	1B-5
Substep Group 1C Equipment Comparability Analysis	1C-1
Substep 1.4 Establish Generic Equipment Structure	1C-7
Substep 1.5 Identify Predecessor System	1C-19
Substep 1.6 Establish Baseline Comparison System	1C-25
Substep 1.7 Establish Proposed System	1C-41
Substep 1.8 Determine Design Differences	1C-53
Substep Group 1D Reliability and Maintainability Analysis	1D-1
Substep 1.9 Determine Reliability and Maintainability Requirements	1D-5
Substep Group 1E Task Identification	1E-1
Substep 1.10 Determine Generic Tasks	1E-5

List of Figures

<u>Figure</u>	<u>Title</u>	<u>Page</u>
1-1	Relationship of System Analysis to other HARDMAN steps.	1-3
1-2	Relationships of System Analysis to other HARDMAN steps.	1-6
1A-1	Logic flow for Mission Analysis.	1A-4
1.1-1	Logic flow for Identify General Mission Requirements.	1A-6
1.2-1	Logic flow for Detailed Mission Requirements.	1A-15
1.2-2	Functional timelines.	1A-18
1.2-3	Mission event sequence example.	1A-21
1.2-4	Mission event sequence diagram example.	1A-23
1.2-5	Path probabilities.	1A-30
1B-1	Logic flow for Functional Requirements Analysis.	1B-4
1.3-1	Logic flow for Determine Functional Requirements.	1B-7
1.3-2	Functional allocation.	1B-18
1C-1	Logic flow for Equipment Comparability Analysis.	1C-5
1.4-1	Logic flow for Establish Generic Equipment Structure.	1C-9
1.4-2	Levels of indenture.	1C-12
1.5-1	Logic Flow for Identify Predecessor System.	1C-23
1.6-1	Logic flow for Establish BCS.	1C-27
1.6-2	Iterative nature of functional criterion application.	1C-30

List of Figures (continued)

<u>Figure</u>	<u>Title</u>	<u>Page</u>
1.7-1	Logic flow for Establish Proposed System.	1C-44
1.8-1	Logic flow for Design Difference Determination.	1C-56
1D-1	Logic flow for Reliability and Maintainability.	1D-3
1E-1	Logic flow for Generic Task Identification	1E-3

List of Tables

<u>Table</u>	<u>Title</u>	<u>Page</u>
1-1	System Constructs vs. Functional Criteria	1-1
1.1-1	Mission Areas	1A-7 - 1A-10
1.1-2	Battlefield Tasks	1A-11
1.2-1	System Operating Metrics	1A-24
1.2-2	MP/OMS Example	1A-25
1.2-3	Operational Modes	1A-28
1.2-4	Travel Distances	1A-29
1.3-1	Mission/Function	1B-9
1.3-2	Generic Functions	1B-9 - 1B-10
1.3-3	Functions Example	1B-12
1.3-4	Performance Measures and Standards	1B-15
1C-1	Distinctions Between the Predecessor, Baseline Comparison, and Proposed Systems	1C-4
1.4-1	EIC Assignment Example	1C-13
1.4-2	TB 750-93-1 Functional Group Codes	1C-14
1.4-3	LCC/MIL-STD-881 Cross-References	1C-15
1.5-1	Acquisition Types	1C-20
1.6-1	HUD Functional/Performance Requirements	1C-31
1.6-2	BCS Candidates	1C-32
1.6-3	Functional Criteria Satisfied	1C-33
1.6-4	Applying Performance Criteria to BCS Candidates	1C-34

List of Tables (continued)

<u>Table</u>	<u>Title</u>	<u>Page</u>
1.6-5	Applying Data Availability Criteria to BCS Candidates	1C-38
1.8-1	Sample Design Different Index (DDI)	1C-54
1.8-2	Design Difference Considerations	1C-58
1.8-3	Design Difference Example	1C-60
1.8-4	Design Difference Impact Example	1C-64
1.9-1	Maintenance Workload Data Elements	10-6 - 10-7
1.9-2	Causes of Maintenance Action	1D-11
1.9-3	R&M Data Sources	1D-13
1.10-1	Analysis Levels	1E-7
1.10-2	Sample Operator Action Words	1E-9
1.10-3	Sample Maintenance Action Words	1E-10

To the Analyst

Volumes II through IV are intended to be used by individual engineers and MPT analysts who have been tasked with conducting the HARDMAN analysis. These volumes provide detailed descriptions of each HARDMAN step, substep group, and substep. The analyst is referred to the preface of Volume I for an overall description of these volumes and a description of the organizational format of each step.

The analysis flow diagrams depict, at a high level, the general flow of data and the interrelationship of the individual HARDMAN substeps (see Volume I, Figures 1.2-3 and 1.2-4). The descriptions of these substeps provide the detailed procedures, algorithms, and rules required to conduct the analysis as well as examples of products that represent the results of the analysis.

In essence, these flow diagrams and substep descriptions provide the analyst with guidance on how to conduct the discrete methodology steps. However, the diagrams and descriptions do not capture much of the dynamics of a study application.

Throughout the substep descriptions, the analyst is directed to interface with other analysts and other data. In most instances, these directions are not intended to reflect formal, one-time meetings, where the output of one substep is passed on as input to the next. Instead, they reflect an ongoing give-and-take between analysts.

In light of that, it cannot be overemphasized to the individual analyst that the HARDMAN methodology is a highly interactive process that is, by necessity, conducted by a multi-disciplinary study team of engineers and analysts. The magnitude and complexity of the factors that are necessary to capture the total operational and maintenance requirements of a weapon system are such that no one analyst or analysis manager can be expected to have a total grasp of the whole.

Each analyst must contribute not just the formal output of his or her discipline's analytical substeps but must participate in partnership with other analysts in

system definition. This is especially true in Step 1 (Systems Analysis), where the decisions about the system's scope and its mission, functional, task, and equipment requirements provide the basis upon which much of the subsequent analysis is conducted.

Finally, the requirement for early identification and collection of data must be stressed. Results obtained from using the substep procedures described in this handbook reflect the quality and completeness of the data that are input. Every analyst must regard as crucial the need to identify data at the earliest possible time and to see to it that data requests are pursued in a timely manner.

Alternative or second-best data may have to be obtained if it appears that initial data requests will not be received in time. The analyst must continuously keep the analysis manager informed of data collection problems, as delays will have a negative impact on study milestones. Accordingly, the analyst should give special attention to the guidance presented in Appendix A (Data Operations) of Volume V.

STEP 1

Systems Analysis

Overview

The Systems Analysis step of the HARDMAN methodology systematically examines identified mission needs and evaluates alternative design approaches to satisfying those mission needs. Mission needs establish the requirement for a new or improved system design.

First, the mission need is identified, and the specific system functions required to meet that need are determined. Next, the analysis determines the system design that will enable the functional requirements to be met. System design includes not only equipment configurations, but operational, organizational, and support concepts as well.

In response to the system functional requirements, at least three system constructs will normally be identified. These include the Predecessor System (the system which is being replaced, if one exists), the Baseline Comparison System (BCS), and the Proposed System (which may include multiple alternatives). As illustrated in Table 1-1, these three constructs are distinguished by two functional criteria: functional performance and performance standards.

Table 1-1. System Constructs vs. Functional Criteria

SYSTEM CONSTRUCTS	FUNCTIONAL CRITERIA	
	Does the System Construct Perform All New System Functions?	Does the System Construct Meet All New System Performance Standards?
Predecessor	No	No
BCS	Yes	No
Proposed	Yes	Yes

Step 1/Overview

Because the Predecessor System meets neither the system functional requirements nor performance standards for the new system, it is being replaced. The BCS is a notional system configuration consisting of a composite of existing fielded systems, subsystems, and equipment. It is assembled for purposes of comparison with Proposed System designs.

BCS component selections are made in order to satisfy all new system functional requirements. However, the BCS may not fulfill all new system performance standards. Finally, by definition, the Proposed System will satisfy all new system functional requirements and performance standards.

Systems Analysis may be performed at different phases of a system acquisition. During later phases, the Proposed System design may be well defined. If performed early in an acquisition at a time when little, if any, new design information is available, the Proposed System design is a projection based on engineering judgment. In this case, the analyst will use the BCS design to project an evolutionary design improvement, one that incorporates low-risk technological advances.

The HARDMAN Systems Analysis step, like the rest of the methodology, is necessarily data-intensive. Data timeliness, completeness, and accuracy are prime concerns throughout Systems Analysis. Despite the fact that Systems Analysis substeps can proceed independently in the early stages of a HARDMAN application, they become increasingly interdependent (see Figure 1-1).

In most situations, delays in data collection actions pose the greatest risk to the smooth progress of each analysis step and, ultimately, to the entire analysis. Planning and coordinating data collection is an

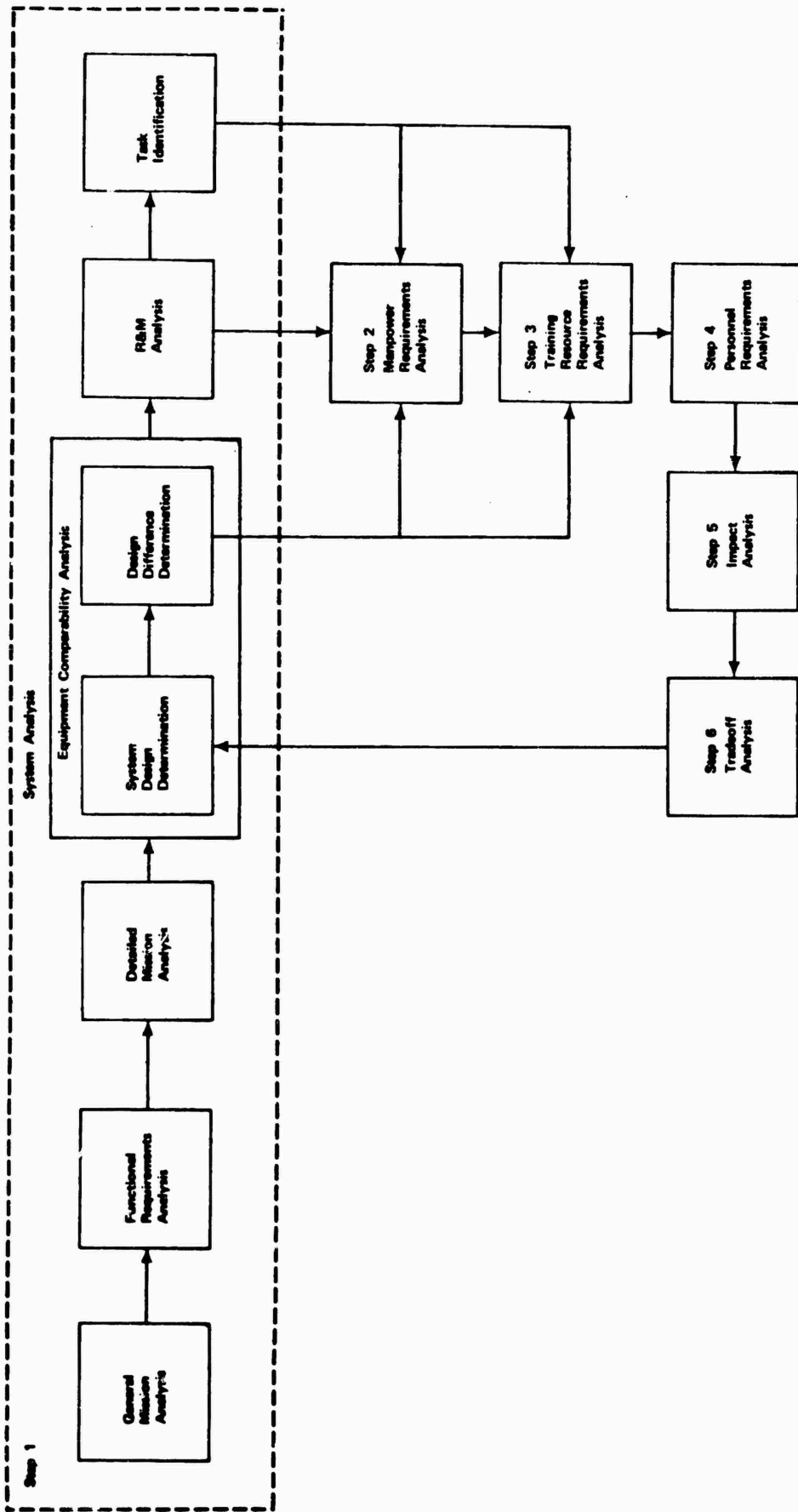

Figure 1-1. Relationship of System Analysis to Other HARDMAN Steps.

Step 1/Overview

immediate concern of any HARDMAN analysis. Specific data collection requirements are discussed in each Systems Analysis substep.

Objectives

The eight major objectives of the HARDMAN System Analysis are:

- To identify the mission needs which require the development of the new system
- To determine the major system functions required to accomplish the mission needs
- To identify the system being replaced, if any

(Meeting the above objectives results in establishment of the Predecessor System.)

- To identify the Proposed System, including actual or projected new system design concepts and equipment configurations as well as potential alternative designs which meet all new system functional requirements and performance standards
- To identify the Baseline Comparison System (BCS) for the purpose of comparison with the Proposed System; the BCS is a notional system configuration which is a composite of existing, fielded systems, subsystems, and equipment; it must perform all new system functions but may not meet new system performance standards
- To identify the design differences between the BCS and the Proposed System and to assess the impacts of the design differences on BCS MPT-related parameters

- To determine the reliability and maintainability parameters for the Predecessor, BCS, and Proposed Systems
- To determine the generic operator and maintainer tasks

Interrelationships

Figure 1-2 presents an overview of the relationship between Systems Analysis and the other HARDMAN steps. Data collection requirements affect all HARDMAN steps but are not shown in Figure 1-1. Collection of program background information, including mission and functional requirements information, must be completed in order to perform Substeps 1A (Mission Analysis) and 1B (Functional Requirements Analysis).

Data collection begins for the remaining HARDMAN steps once the Predecessor, BCS, and Proposed System designs have been identified in Substep 1C (Equipment Comparability Analysis). To maximize efficiency and consistency, data collection efforts for all HARDMAN steps must be carefully coordinated.

As illustrated in Figure 1-2, the comparability analysis performed in Step 1 is essential for projecting Proposed System manpower and training requirements. As such, design differences and their impacts are input to Steps 2 (Manpower Requirements Analysis) and 3 (Training Resource Requirements Analysis), respectively.

Reliability and maintainability analysis provides the basis for aggregating maintenance workload requirements as a preliminary step to computing manpower. Generic task identification contributes to manpower and training resource requirements analyses. Feedback to Systems Analysis occurs during examination of alternative system design within Step 6 (Tradeoff Analysis).

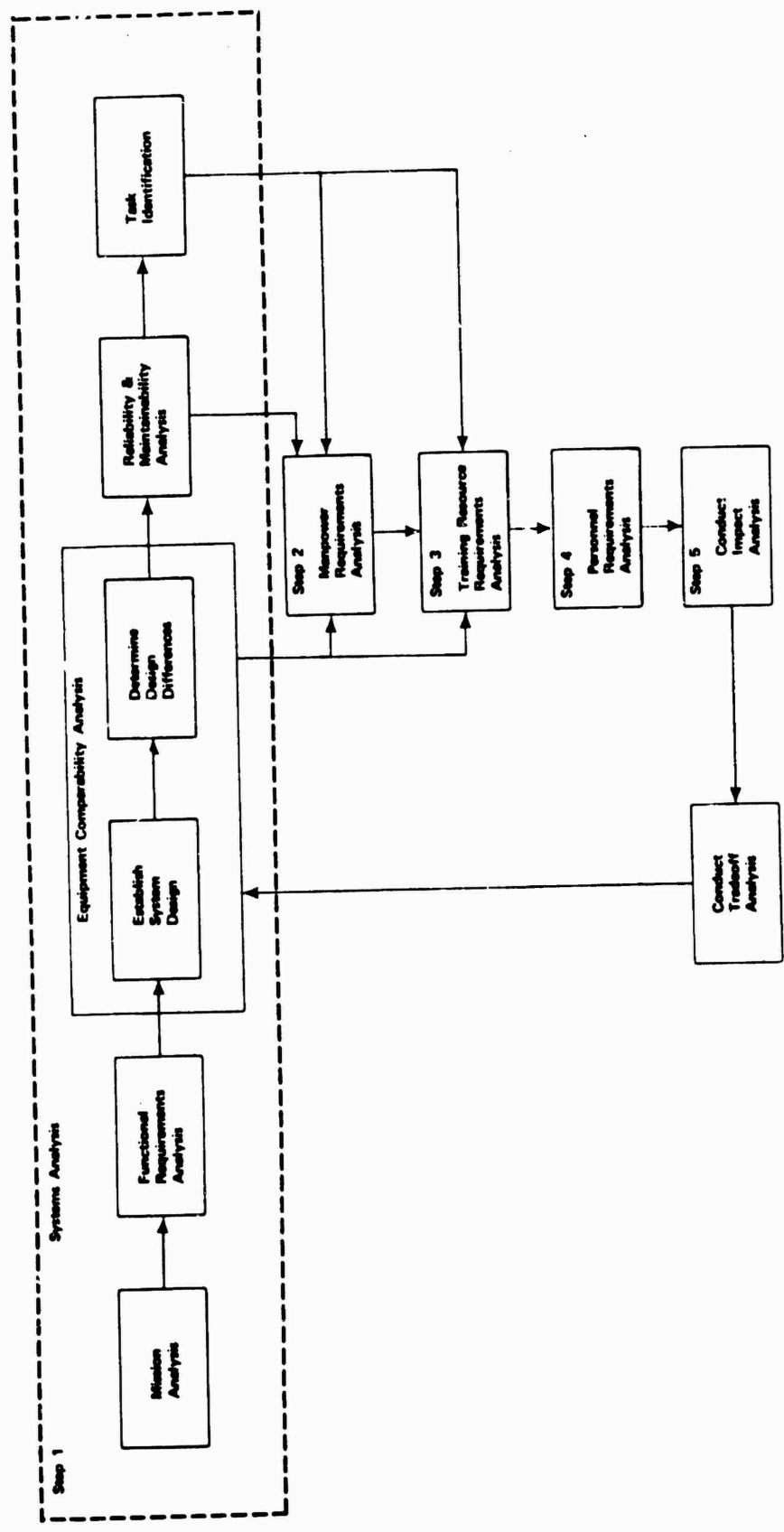

Figure 1.2. Relationships of system analysis to other HARDMAN steps.

**Assumptions/
Constraints**

The following assumptions and constraints must be kept in mind when conducting Step 1 of a HARDMAN analysis:

- All results of the System Analysis are based on the best available data. Incomplete or inaccurate input data may produce misleading results and invalidate conclusions.
- Information on Proposed System alternatives may be sensitive among competitors and, for that reason, difficult to obtain.
- When Proposed System data are not available from a prime contractor or government source, they will be estimated on the basis of BCS data.
- The projected design of the Proposed System will be determined on the basis of the BCS system construct and will incorporate low-risk technological improvements. Design differences between the BCS and the Proposed System design are then documented.
- Impacts of BCS/Proposed System design differences are estimated. Design difference impacts are used to perturb BCS parameters (such as R/M values) to derive Proposed System parameter estimates.
- Design differences must be updated and revised as actual Proposed System design data become available.
- When Proposed System data are available, BCS data will not be perturbed but will serve only as a basis of comparison.

Comparability Analysis

Comparability analysis is the primary technique for performing a HARDMAN Systems Analysis. Within this step, comparability analysis consists of systematically comparing the BCS and Proposed System constructs.

When the Proposed System is not completely defined, BCS performance capabilities are compared to Proposed System performance requirements. Low-risk technological advances are incorporated into BCS components to derive a projected Proposed System design.

Comparability analysis is the means by which BCS/Proposed System design differences are identified and evaluated. Due to its impact on subsequent HARDMAN analysis steps, all design differences which could impact system MPT resource requirements must be identified.

Due to the evolutionary nature of system development, HARDMAN comparability analysis is an ongoing process. The evolving Proposed System design must be continually compared to the BCS, and the design differences must be updated accordingly.

Substep Group 1A

Mission Analysis

Purpose

A HARDMAN analysis estimates the manpower, personnel, and training (MPT) requirements for materiel systems, typically in the early phases of the Army's Life Cycle System Management Model (LCSMM). MPT requirements estimates are produced for operators and maintainers of the new system. The estimates must be uniquely associated with a specified set of system missions on the battlefield under the environmental conditions likely to be found there.

The format for military operations orders defines "mission" as a clear, concise statement of a task, or tasks, to be accomplished by a command. Task purpose is also stated. By implication, missions may be assigned to any element of the command.

As used in HARDMAN, a "system" is a combination of people, equipment, and information which, when taken as a whole, is capable of performing a required mission. Thus, missions assigned to a specific system support accomplishment of the overall mission assigned to the command, or unit, to which the system belongs.

As with general missions assigned to units, the particular characteristics of system missions vary with the unit's/system's mission area. Mission areas are broad subdivisions of the Army's overall mission, which is to prepare for, engage in, and win land wars.

TRADOC Regulation 11-8 (Combat Development Studies) defines twelve mission areas and assigns each to a proponent TRADOC school or center. Boundaries for some mission areas are clear, as the mission area is congruent with the types of units, forces, and personnel for which the proponent is responsible.

Step 1A/Overview

Examples are Armor (Close Combat--Heavy Mission Area) and Air Defense (Air Defense Mission Area). In other mission areas, such as command and control, communications, and combat service support, the boundaries are less clear. There, the proponent's responsibilities are an integral part of all mission areas.

A HARDMAN Mission Analysis has two objectives. The first is to identify the mission area(s) supported by the system under study. This serves to place the system within a well-defined context.

Because MPT information is also sorted by proponent and mission areas, establishing a well-defined mission area context for the system at the outset of a HARDMAN application narrows requirements for data collection. Further, some HARDMAN procedures, such as Substep Group 2A (MOS/Grade Determination), draw heavily on the mission area context.

The second purpose of Mission Analysis is to derive detailed system usage/activity rates from the general information provided in the system's statement of missions and expected environment. Although estimates of operator and maintainer MPT requirements are derived differently, both depend on detailed, integrated, and logically consistent system usage/activity data. These data are the quantifiable result of the system's performance in response to its mission requirements under the prescribed conditions.

Often, system mission requirements and/or environmental conditions are stated at a very general level. Either no usage/activity data exist, or, if specified, they may not be integrated or may lack sufficient detail to derive accurate rates.

Logic

Figure 1A-1 depicts the logic flow for determining a system's general and detailed mission requirements. No other HARDMAN step provides input to Mission Analysis.

Substeps comprising Substep Group 1A are:

- 1.1 Identify General Mission Requirements
- 1.2 Identify Detailed Mission Requirements

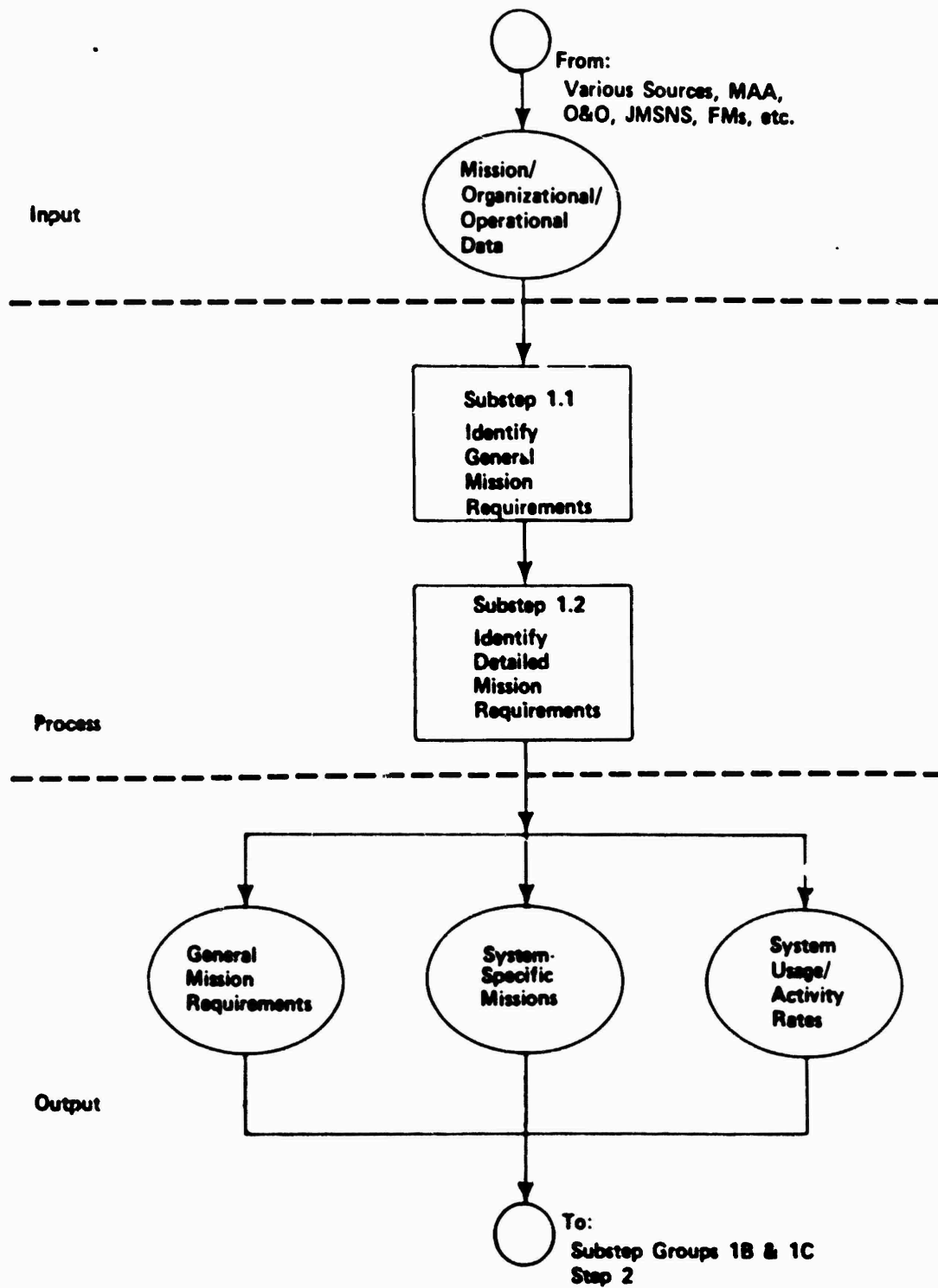

Figure 1A-1. Logic flow for Mission Analysis.

Substep 1.1/Overview

Identify General Mission Requirements

Objectives

The purpose of this substep is to place the system being studied in the context of one or more standard Army mission areas. Because manpower, personnel, and training (MPT) information is also sorted by mission areas, establishing a well-defined mission area context for the system at the outset of a HARDMAN application narrows requirements for data collection. Further, identification of the context is a prerequisite for performing some HARDMAN substeps.

Input

No other HARDMAN substeps provide input to this substep. Inputs from other sources include the Mission Area Analysis (MAA) for the mission area of the system under analysis; the system's Organizational and Operational (O&O) Plan, if available; and general sources of doctrinal information such as the how-to-fight field manual (FM) series for the system's mission area.

Products

This substep produces two outputs. The first is a list of general mission requirements which apply to the system, based on placing the system in one or more mission areas. The second output describes specific system missions, to the extent that they can be determined from available documentation.

Logic

The process of identifying a system's general mission requirements is a judgmental one. It relies heavily on the analyst's skill and knowledge of the system's mission requirements and expected environment. Figure 1.1-1 depicts the logic flow for determining general mission requirements. This substep contains one action step.

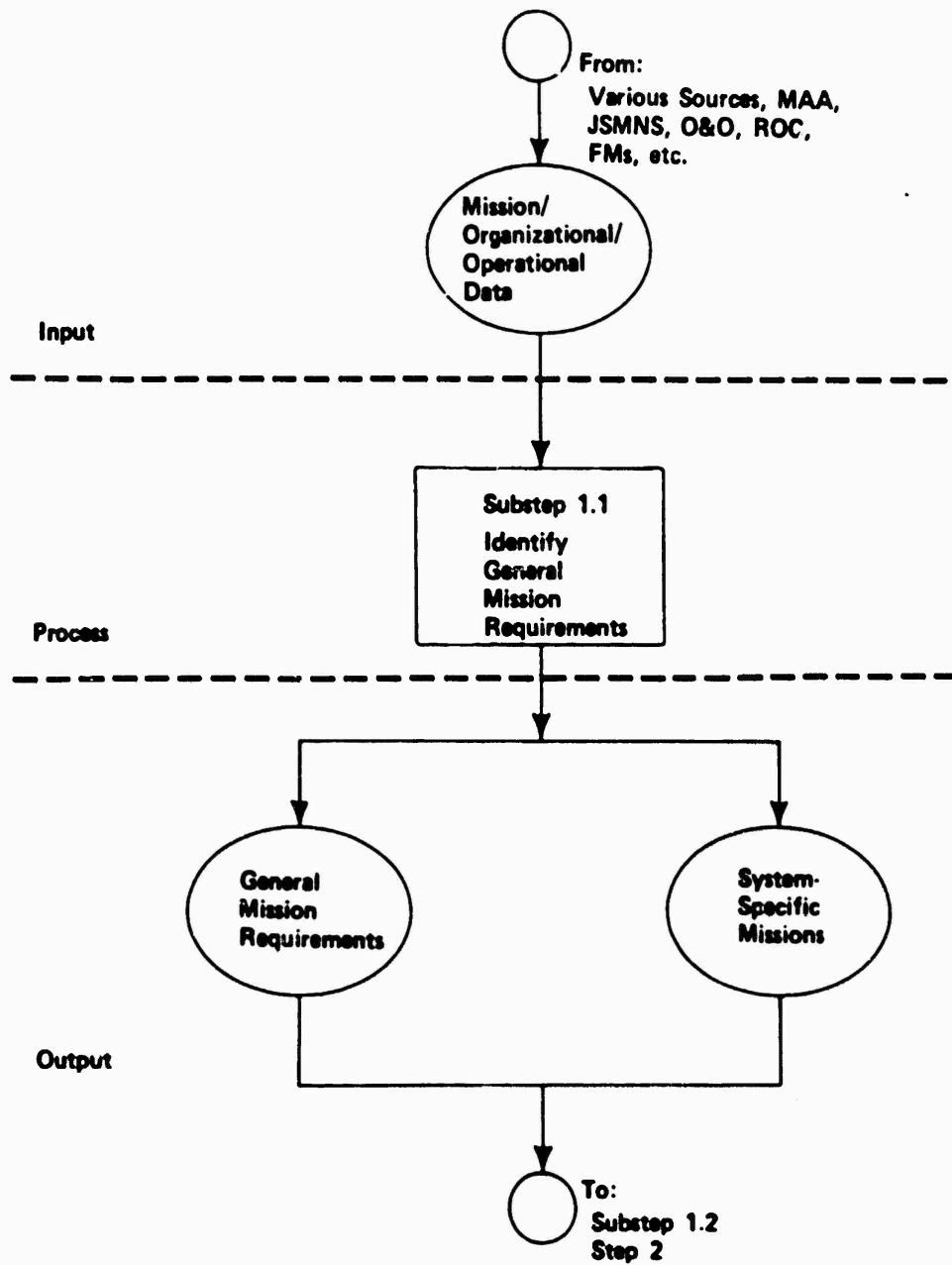

Figure 1.1-1. Logic flow for Identify General Mission Requirements.

Action Step**Requirements**

In this action step, the analyst determines the mission area(s) to which the system under study belongs and determines specific missions that may be assigned to that system.

Objective

The objective is to determine the mission area(s) and specific missions that may be assigned to the system under analysis.

Procedures

1. Using available documentation, the analyst determines the mission area or areas to which the system under analysis belongs. Table 1.1-1 provides a list of the twelve mission areas defined in TRADOC Regulation 11-8 (Combat Development Studies). Also shown in Table 1.1-1 is the TRADOC school or center responsible for efforts supporting the mission area. The schools or centers are referred to as "proponents."

Table 1.1-1. Mission Areas

<u>Mission Area</u>	<u>Description</u>	<u>Proponent</u>
Close Combat, Light	Efforts directly related to the generation of combat power by light forces for target servicing enemy forces within line of sight of primary weapon systems. Included are programs for combat mobility, mortars, and anti-armor capability.	Infantry School
Close Combat, Heavy	Efforts directly related to generation of combat power by heavy forces for the purpose of target servicing enemy forces within line of sight of primary weapon	Armor School

A/Substep 1.1

Table 1.1-1. Mission Areas [con't.]

<u>Mission Area</u>	<u>Description</u>	<u>Proponent</u>
	systems. Included are programs for combat mobility, mortars, and anti-armor capability.	
Fire Support	Efforts directly related to generation of indirect fire combat power for destroying, disrupting, suppressing, or neutralizing enemy forces. This encompasses target servicing of enemy forces engaged in the direct fire battle, counterfire of enemy indirect fire systems, and the interdiction of all other forces not involved in direct fire battle. Included are programs for field artillery weapons and munitions and target acquisition means considered integral to the fire support system. Offensive chemical and nuclear fire support and the lethal attack of emitters are integral to this mission area.	Field Artillery School
Air Defense	Efforts directly related to destroying, nullifying, or reducing effectiveness of enemy air-breathing and tactical ballistic systems. Included are friendly target acquisition means considered integral to the air defense system as well as other air defense sensors and related command and control.	Air Defense School
Communications	Efforts related to the capability to provide accurate, timely communications among tactical units and between tactical and strategic networks. Included is the capability to communicate in an enemy-induced EW environment.	Signal School

Table 1.1-1. Mission Areas [con't.]

Mission Area	Description	Proponent
Command and Control	Efforts related to capabilities required to analyze information, assess situation, and direct and control tactical units during combat operations. Includes tactical information systems and systems for controlling and releasing nuclear weapons.	Combined Arms Center Development Activity
Intelligence and Electronic Warfare	Efforts related to the capability to determine movement, character, disposition, type, and intention of hostile units to support battlefield management and acquisition of targets for combat actions. Includes surveillance in support of command and control and means to correlate, integrate, and fuse this information with other sensor systems into intelligence. Also includes the capability to detect, identify, locate, report, disrupt, deceive, and exploit hostile electromagnetic systems. Excludes target acquisition capabilities integral to a class of firepower means.	Intelligence School
Combat Support, Engineering and Mine Warfare	Efforts related to combat engineer operations and mine/countermine warfare. Encompasses position fortification to enhance survivability, emplacement of barriers and obstacles to impede enemy movement, and breaching of natural and man-made obstacles to improve friendly force movement. Included are artillery-delivered mines, engineering support in construction and road maintenance, bridging, electrical power support, and mine clearing.	Engineer School

A/Substep 1.1

Table 1.1-1. Mission Areas [con't.]

<u>Mission Area</u>	<u>Description</u>	<u>Proponent</u>
Combat Service Support	Efforts directly related to capabilities providing land tactical commanders with supply, maintenance, services, energy, medical, and personnel administration support. Encompasses essential battle support to committed forces, ordinary and extraordinary measures taken to reconstitute the force continuously, and rapid movement of troops and supplies to concentrate combat power at critical times and places. Includes only those transportation system capabilities controlled by senior land tactical commanders.	Logistics Center assisted by Soldier Support Center
NBC	Capabilities required to support combat efforts operating in a nuclear, bacteriological, or chemical environment and offensive (less fire support) chemical warfare.	Chemical School
Aviation	Capabilities provided to the land tactical commander by fixed and wing aircraft.	Aviation School
Special Operations	Capabilities required to conduct unconventional warfare, participate in foreign internal defense matters, strike operations, reconnaissance, civil affairs, and psychological operations in support of national authorities and/or the land tactical commander.	Special Warfare Center

2a. The analyst subdivides the mission area into logical categories to determine the specific missions that may be assigned to the system under analysis. A mission area may be subdivided according to the type of activities that the forces and systems contained within mission areas are expected to accomplish on the battlefield. Current MAA documentation refers to these activities as "tasks."

In FARDMAN, "task" is defined as an action involving human performance below the level of a system. The analyst is cautioned not to confuse these two meanings of the term. Table 1.1-2 provides examples of battlefield "tasks."

Table 1.1-2. Battlefield Tasks

Mission Area :	Fire Support
Tasks :	Control Battle Maneuver Acquire Target Receive Targeting Information Process Target Attack Target Assess Target Attack

As described above, these tasks are "functional" in nature. In other words, they refer to the functions that must occur within the mission area.

2b. Another way to subdivide the mission area is to refer to the outcomes of the process. These outcomes are often found in doctrinal literature, such as the how-to-fight field manual series which pertains to the mission area.

A/Substep 1.1

Example

After consulting FM 6-20 (Fire Support in Combined Arms Operations), the analyst determines that Fire Support is expected to deliver four types of fire: Close Support Fire, Counterfire, Interdiction, and Other, such as suppression of enemy air defense (SEAD). The analyst would also consider this outcome or product-oriented classification in determining the specific missions appropriate to the mission area that may be assigned to the system under analysis.

Substep 1.2/Overview

Identify Detailed Mission Requirements

Objectives

This substep derives detailed usage or activity data which corresponds to the system under analysis and to the subsystems, components, and assemblies which comprise it. A detailed statement of the usage/activity required of a system under a combat scenario may not be available early in a system's development, when HARDMAN is typically applied.

On the other hand, several distinct, non-integrated, and mutually exclusive specifications of required activity may exist. This depends on the complexity of the system, the number of battlefield functions it is expected to perform, the number of different operating environments, and the length of time it is expected to operate. The objectives of this substep are (1) to develop the required usage/activity information when none or little is available and (2) to integrate and normalize the available information as required.

Input

Input to this substep from other HARDMAN substeps includes the general mission context of the system under analysis and the specific missions assigned to it from Substep 1.1 (Identify General Mission Requirements). Substep 1.3 (Determine Functional Requirements) contributes system functions and functional requirements.

Other input includes the Mission Area Analysis (MAA) for the mission area of the system under analysis; the system's Operational and Organizational (O&O) Plan, including the Mission Profile/Operational Mode Summary if available; and general sources of doctrinal information, such as the how-to-fight field manual series for the system's mission area.

Substep 1.2/Overview

Products

The detailed mission requirements identification process produces the usage/activity rate for each system. This rate is the quantification of system usage in miles driven, rounds fired, hours operated, etc., required over time to accomplish the system's assigned missions.

Logic

This substep is performed because detailed system usage data required for other HARDMAN steps may not be available. If the data are available, however, detailed development of system usage/activity data is abbreviated.

Analysis is limited to insuring that the data are, in fact, suitable to input to other HARDMAN substeps. At the other extreme, no detailed, system-specific usage/activity data may be available to the analyst. In that case, the analyst must develop the data "from scratch."

Having no data at all is particularly undesirable, since it places the HARDMAN analyst in the position of developing data which are really in the province of combat doctrine. While the HARDMAN methodology must be sensitive to doctrine, doctrinal development is not part of the methodology.

The most likely situation is that some detailed usage/activity data are available. The analyst clarifies, rationalizes, and interprets available data to derive a complete set of detailed system usage/activity data. This derivation process is definitely judgmental. It relies heavily on analyst skill and knowledge of the system's mission requirements and expected environmental conditions.

Figure 1.2-1 depicts the logic flow for determining detailed mission requirements. As shown in the figure, this substep comprises four action steps.

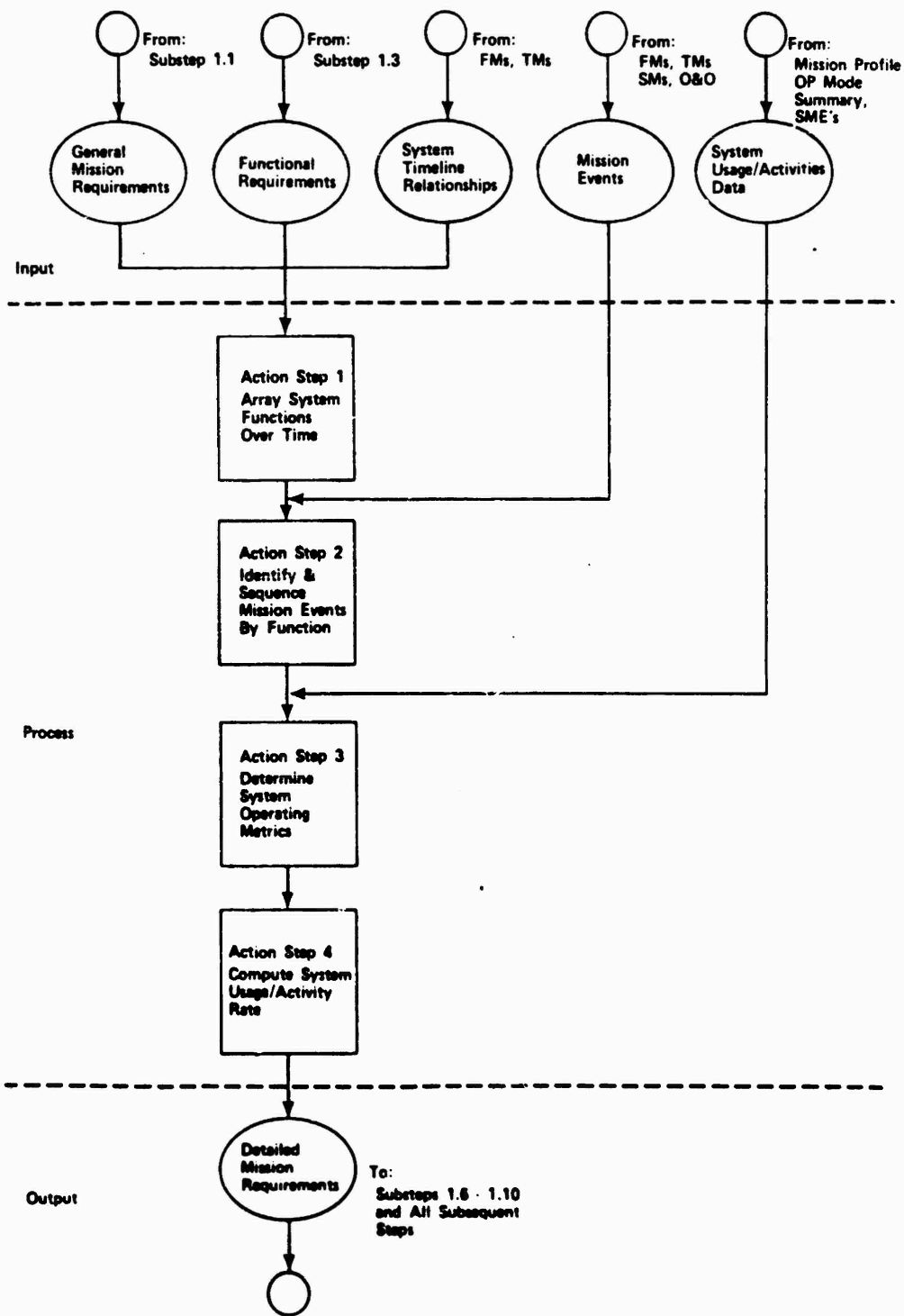

Figure 1.2-1. Logic flow for Detailed Mission Requirements.

A/Substep 1.2

Action Steps

Action Step 1: Array System Functions Over Time

Requirements

System functions were identified in Substep 1.3 (Determine Functional Requirements). In this action step, the analyst establishes the temporal relationships between and among system functions.

Objective

Given a particular group of functions, the objective of this substep is to determine which can be done sequentially and which simultaneously. On the other hand, to complete some missions, sequential or simultaneous performance is required rather than left to operator discretion. Establishing the temporal relationships, or timelines, identifies these situations for the analyst.

Procedures

1. Substep 1.3 (Determine Functional Requirements) identified the functions required to perform the system's assigned missions. Such functions may be required to support several missions. The analyst establishes which are required for a particular mission.
2. For a particular mission, the analyst examines system functions to establish two categories: sequential and simultaneous. Doctrinal field manuals, particularly the how-to-fight series, and technical manuals for existing systems within the mission area are principal sources of timeline relationships of system functions.

3. The analyst establishes the temporal relationship among the functions by answering the following questions:

- Given that all system functions are essential to successful accomplishment of battlefield missions, are all functions equally possible at any particular point in time?
- Are functions mutually exclusive?
- Is the arrangement of functions "permissive"? In other words, can system operators vary the relationship among functions according to conditions prevailing on the battlefield?
- Is the arrangement of functions "prescribed," i.e., fixed either by doctrine or the constraints of the prevailing technology?

Example

A tank may shoot and move simultaneously if it has a gun stabilization system. Shooting on the move is a capability required of current tanks. A howitzer, on the other hand, must be stationary when firing. Therefore, shooting and moving are mutually exclusive functions for the howitzer.

Both the tank and the howitzer are required by doctrine to communicate continuously. Consequently, communications is a simultaneous function in both systems.

Figure 1.2-2 depicts the functional timelines of a tank and of a howitzer.

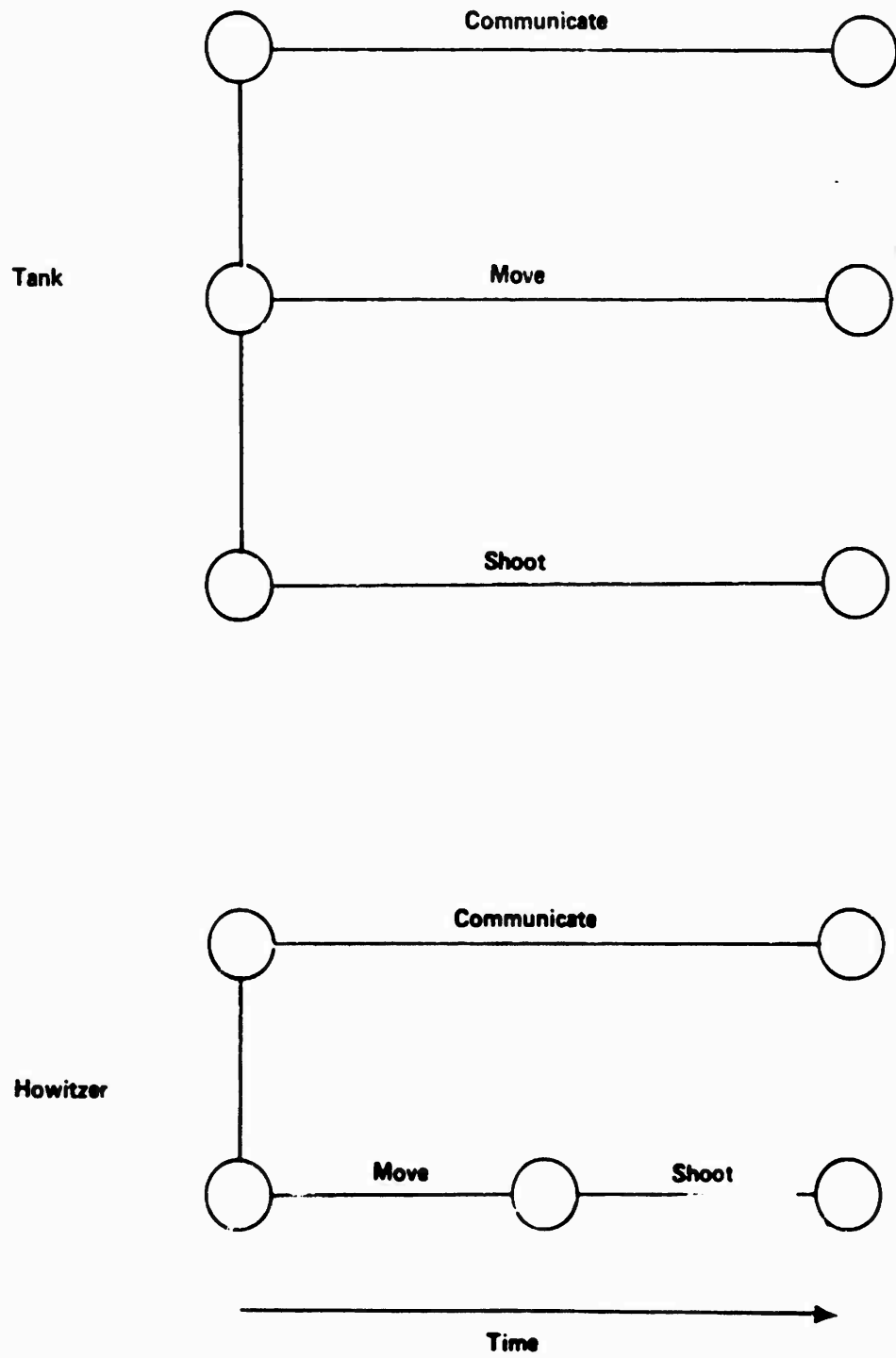

Figure 1.2-2. Functional timelines.

Action Step 2: Identify and Sequence Mission Events Required By Each Function

Requirements

Mission events are the separate, discrete actions which comprise a function. The analyst must identify the mission events which apply to the functions of concern. Following the logic of the previous action step, the analyst must also establish the temporal relationship, or timelines, among the mission events.

Objective

The purpose of this action step is to identify and place in sequence the mission events that comprise each function.

Procedures

1. Mission events embody functions at a lower level of detail. Which mission events comprise a function can be determined by the analyst through research and through professional judgment, both on the part of the analyst and any subject-matter experts consulted. The analyst divides the function into discrete actions which fully describe the system's performance of the function.
 2. Mission events can be found in many of the same sources as the required system functions. These sources include doctrinal field manuals, especially the how-to-fight series for the system's mission area; operator manuals; soldier's and trainer's guides for the Predecessor System, if one exists; and employment or operational concepts contained in the new system's Operational and Organizational (O&O) Plan.
 3. Once mission events are identified, the analyst uses the same logic as Action Step 1 to establish a prescribed sequence of mission events. Because mission events outnumber functions, mission events can be combined in more ways. Instead of a prescribed or definite sequence of mission events, several sequences may be desired under different employment conditions.
-

A/Substep 1.2

The sequence or set of sequences finally decided on usually depends on decision rules which are either implicit or explicit in the governing employment of the system. The analyst must uncover these rules, make them explicit, and use them to construct mission event sequences, or timelines, which are both acceptable to Army users and sufficient to support subsequent HARDMAN steps.

Examples

Example 1

For the howitzer of the previous example, the analyst identifies the following mission events for each function:

<u>Function</u>	<u>Mission Event</u>
Communicate	Communicate
Shoot	Fire Mission
Move	Disemplace Transit Emplace

Figure 1.2-3 depicts the sequence of these mission events.

Example 2

Situation. A ground missile launcher has two missiles. The system will operate by shuttling between a launch area, a hiding area, and a missile resupply point. A mission cycle begins when the system leaves the resupply point and ends when, having fired both missiles, the system returns to the resupply point. The system may fire both missiles at one launch area, fire and move to a hiding area, or move to another launch area directly. The analyst must construct a sequence of mission events to cover the possible movements of the missile launcher.

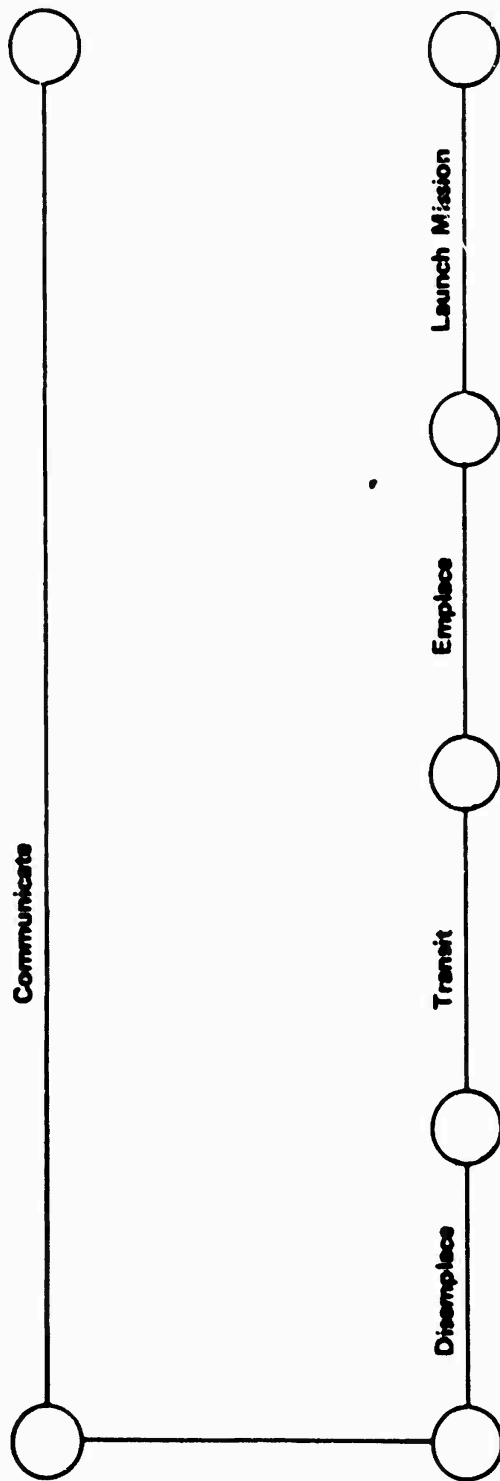

Figure 1.2.3. Mission event sequence example.

A/Substep 1.2

Results. The analyst makes one simplifying assumption and confirms it with subject-matter experts. The assumption is that if the system enters a launch area, it will fire one of its missiles. Assuming this, the analyst can construct a mission event sequence diagram (see Figure 1.2-4).

Action Step 3: Determine System Operating Metrics

Requirements System usage and activity can be accounted for by different units of measure, or metrics. One or several metrics may apply to the operations of a single system. Regarding the system being studied, the analyst must identify which metrics apply to the system as a whole and which apply to its constituent elements.

Objective The purpose of this step is to identify the operating metrics that best characterize the operations of the system under analysis.

Procedures

1. For the system being studied, the analyst determines what units of measure are relevant to its operational requirements. Military Standard 1388-2A (Logistic Support Analysis Record Data Elements and Requirements) provides a list of operating metrics under the term "Measurement Base." Table 1.2-1 lists these metrics.

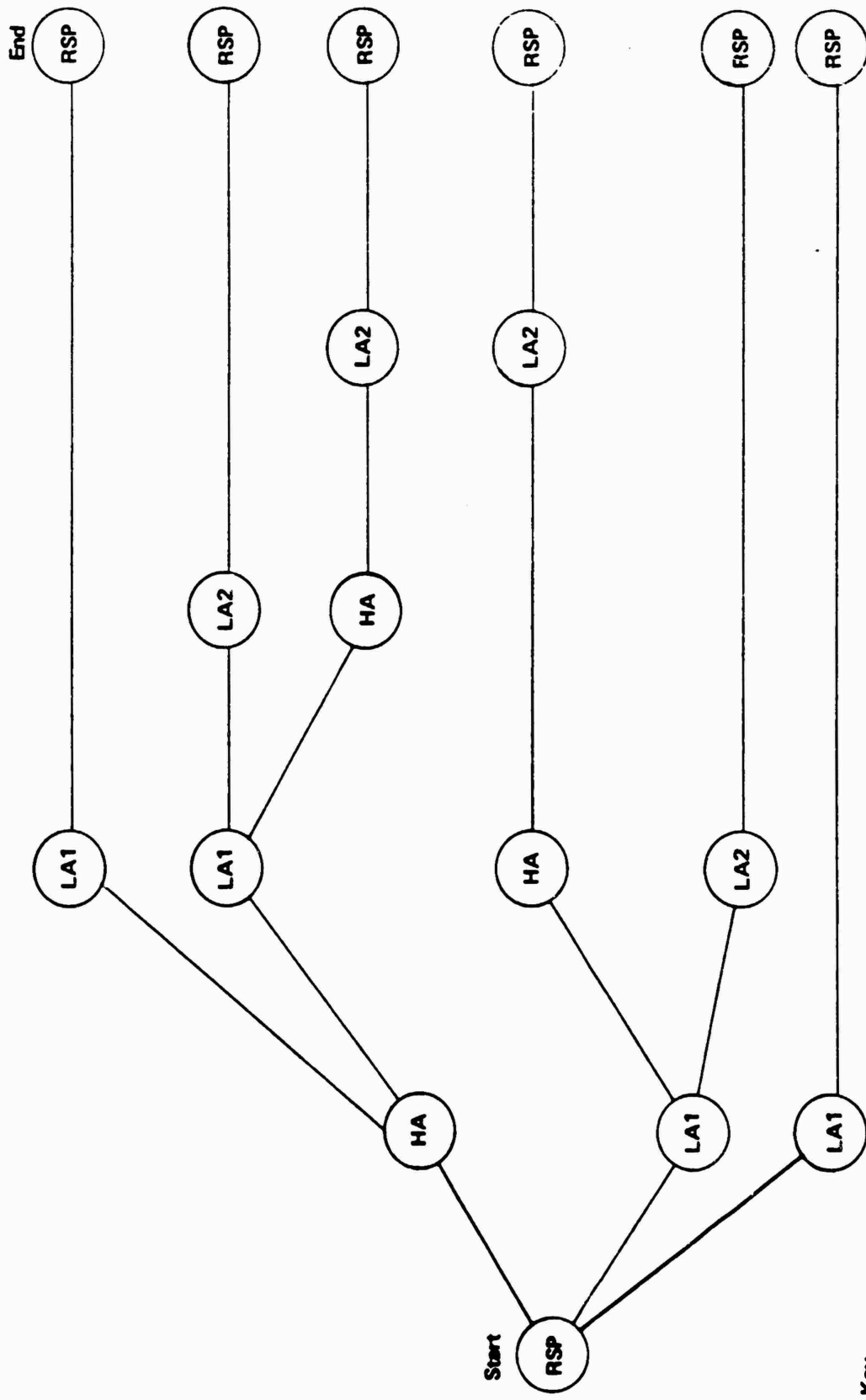

Figure 1.2-4. Mission event sequence diagram example.

Table 1.2-1. System Operating Metrics

<u>Time-Related</u>	<u>Distance-Related</u>	<u>Event-Related</u>
Minutes	Miles	Cycles
Hours	Kilometers	Starts
Days		Landings
Months		Rounds
Years		
Flight Hours		
Operating Hours		
Underway/Steaming Hours		

2. If available, the system's Mission Profile/Operational Mode Summary may provide essential but not necessarily all system operating metrics.

3. Operations of multiple-function systems are typically described by more than one operating metric. These metrics apply to different system elements.

If the relationship among the metrics is constant, it may be useful for the analyst to normalize the different metrics. To normalize, the analyst obtains a factor for converting one metric to another. However, if the relationship is not constant, it is advisable to leave the metrics distinct.

Examples

Example 1

Table 1.2-2 provides an example of a Mission Profile/Operational Mode Summary (MP/OMS) for a hypothetical system.

Table 1.2-2. MP/OMS Example

Mission Essential Function	Mission Profile			Annual Usage
	Static	Dynamic	Ground Support	
Fire Control	14 hrs	24 hrs	0 hrs	3,060 hrs
Shoot	240 rds	160 rds	360 rds	46,000 rds
Mobility	12 mi	30 mi	30 mi	3,300 mi
Expected Percentage	75	20	5	N/A

Climatic Design Types (AR 70-38)	% Fleet
Hot	20
Basic	60
Cold	15
Severe	5

Movement Terrain
10% Primary Road
35% Secondary Road
55% Cross Country

Source: AMC/TRADOC Pam. 70-11

Example 2

Situation. A self-propelled howitzer is expected to fire 300 rounds daily and to operate 20 hours daily. Travel between firing locations and the resupply point will probably total 15 miles daily. The relationship among the metrics is assumed to be constant for logistics planning purposes.

Results. The analyst decides to normalize in order to simplify future computations. He selects operating hours as the prime operating metric and expresses the other

A/Substep 1.2

metrics in terms of system operating hours. The analyst obtains the following conversion factors:

$$\frac{\text{Rounds}}{\text{Operating Hour}} = \frac{300 \frac{\text{Rounds}}{\text{Day}}}{20 \frac{\text{Operating Hours}}{\text{Day}}} = 15 \frac{\text{Rounds}}{\text{Operating Hour}}$$

$$\frac{\text{Miles}}{\text{Operating Hour}} = \frac{15 \frac{\text{Miles}}{\text{Day}}}{20 \frac{\text{Operating Hours}}{\text{Day}}} = .75 \frac{\text{Miles}}{\text{Operating Hour}}$$

Action Step 4: Compute System Usage/Activity Rate

Requirement

The final action in the mission analysis process is to calculate the usage/activity rate for each system. The analyst must combine the system operating metrics, the sequence of mission events, and the scenario requirements contained in the Mission Profile/Operational Mode Summary to determine the usage/activity rate for one cycle of mission events. The usage/activity rate is also determined for the total number of cycles necessary to satisfy the scenario requirements.

Objective

The purpose of this action step is to compute the usage/activity rate for each system.

Procedures

1. The analyst applies the operating metrics identified in Action Step 3 to the sequence or cycle of mission events determined in Action Step 2. For each mission event, the analyst determines a numerical value for the metric. The analyst obtains values through logic and research. Professional judgment is also exercised by the analyst and subject-matter experts, particularly combat developers for the system's mission area.
2. The analyst aggregates the values obtained for each mission event. The result of this process is a mission event sequence quantified by the number of operating metrics required to perform one full sequence.
3. The analyst applies the total expected usage requirements in the Mission Profile/Operational Mode Summary (MP/OMS) to the cycle of mission events determined in Procedures 1 and 2. An MP/OMS may describe the expected percentage of time the system will spend in different operational modes (e.g., surge, intense, sustained, normal) on the battlefield.

The analyst should obtain a value for expected usage during a period which is a composite of these different modes. The composite is a weighted average, where the weights are established by the expected time percentages provided in the MP/OMS.

4. The total system usage/activity rate for a period is the product of the usage/activity in one mission event cycle and the number of cycles required to satisfy the mission-essential usage prescribed by the MP/OMS.

A/Substep 1.2

Examples

Example 1

Situation. The missile launcher described in Action Step 2 has three operational modes (see Table 1.2-3).

Table 1.2-3. Operational Modes

	MODE		
	Surge	Intense	Sustained
Missiles Launched Per Week	150	100	60
Expected Percentage of Time in Mode	10	35	55

The analyst must calculate the average number of missiles fired per week.

Results. The analyst obtains the following results:

$$\begin{aligned}\text{Missiles/week} &= \\ &(150 \times .10) + (100 \times .35) + (60 \times .55) \\ &= 15 + 35 + 33 \\ &= 83 \text{ missiles/week}\end{aligned}$$

Example 2

Situation. The situation of the previous example is continued here. The analyst must obtain the total distance traveled during one mission event sequence. In constructing that sequence, the analyst notes that the launcher may travel six unique paths during a mission event cycle.

In examining the system's O&O plan and from discussions with SMEs, the analyst obtains the frequency, or probability, that the system will follow a particular path as well as the average distances between the points. Figure 1.2-5 shows the paths with their associated probabilities. Table 1.2-4 lists the distances between points.

Table 1.2-4. Travel Distances

From	To	Average Distance (Miles)
Resupply Point	Launch Area	2.0
Resupply Point	Hiding Area	1.0
Launch Area	Hiding Area	.5
Launch Area	Launch Area	3.0

The analyst must compute the average distance traveled for one mission event cycle.

Results. The analyst obtains the following results:

Path	Distance Traveled on Path	x	Path Probability	=	Miles
1	1 + .5 + 0 + 2 = 3.5		.10		.35
2	1 + .5 + 3 + 2 = 6.5		.25		1.625
3	1 + .5 + .5 + .5 + 2 = 4.5		.25		1.125
4	2 + .5 + .5 + 2 = 5.0		.10		.50

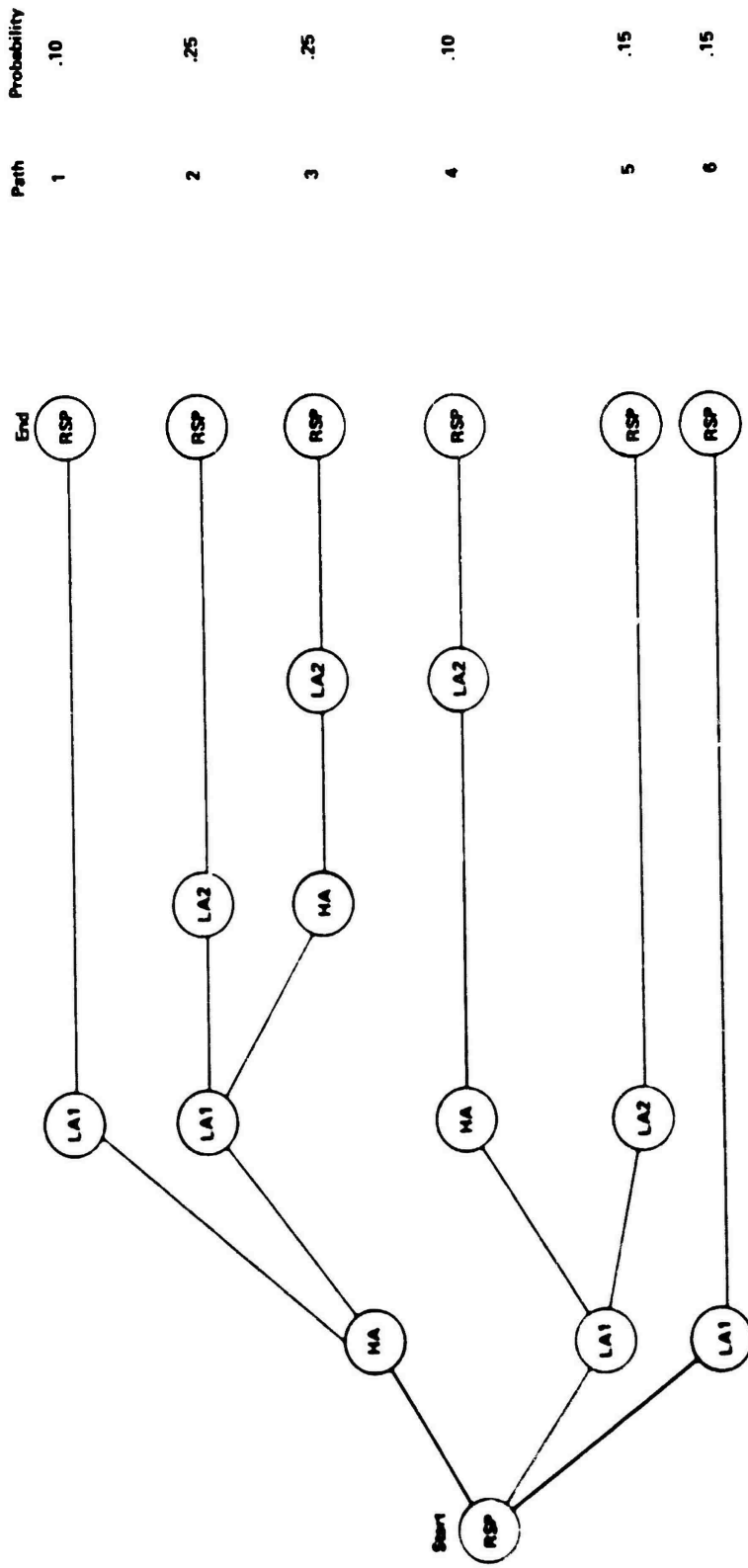

Path	Probability
1	.10
2	.25
3	.25
4	.10
5	.15
6	.15

Key
 LA : Launch Area
 MA : Holding Area
 RSP : Resupply Point

Figure 1.2-5. Path probabilities.

Path	Distance Traveled on Path	x	Path Probability	=	Miles
5	2 + 3 + 2 = 7.0		.15		1.05
6	2 + 0 + 2 = 4.0		.15		.60
TOTAL					5.25 miles

Example 3

Situation. The analyst must determine the miles traveled to complete the weekly launch requirement of 83 missiles as determined in Example 1.

Results. The analyst obtains the following results:

$$\begin{array}{r}
 83 \text{ missiles} \\
 \hline
 \text{week} \\
 \hline
 2 \text{ missiles} \\
 \hline
 \text{cycle}
 \end{array}
 \times 5.25 \frac{\text{miles}}{\text{cycle}} = 217.9 \text{ miles}$$

This page intentionally left blank.

Substep Group 1B

Functional Requirements Analysis

Overview

Functional Requirements Analysis determines the range (what) and depth (to what extent and/or how well) of the functions that the system is required to perform on the battlefield. In theory, new systems are required because of (1) recognized deficiencies in existing systems or (2) the lack of any existing system which is capable of responding to the perceived threat.

OMB Circular A-109 (Major System Acquisitions) specifies that a new system requirement must be justified by showing how that system's capability fulfills a mission need. The objective of the Army's Mission Area Analysis (MAA) process is to provide this justification.

The MAA is a valuable resource for the HARDMAN analyst in determining functional requirements of a new system. It is especially valuable if it includes the specific logic leading to the system's justification. However, the MAA's usefulness is limited for two reasons.

First, the MAA process is designed to address deficiencies in current capability, whether in materiel systems, training, doctrine, or organizations. Thus, if an MAA produces a requirement for a new materiel system, in-depth discussions are usually limited to deficiencies that the new system must overcome. Existing, satisfactory capabilities are assumed to continue.

Clearly, the subset of requirements consisting only of the deficiencies to be overcome is insufficient for the HARDMAN analyst. Manpower, personnel, and training (MPT) requirements must be developed for the entire system.

The second limiting factor is timeliness.

Because MAAs are conducted on a two- or three-year cycle, system requirements developed out of cycle may only be indirectly related to the last MAA. Therefore, the relationship of the functional requirements of the system to its overall contribution to mission performance should be identified.

Thus, the basis for justifying a new system rests directly on its ability to perform on the battlefield and to do so in a manner superior to that of the existing system. The question of what is specifically required of the system on the battlefield is essential to the evolution of systems in the acquisition process. The purpose of Functional Requirements Analysis is to answer this question in sufficient detail to support subsequent analyses.

Logic

The emphasis placed on detailed delineation of system functions through Functional Requirements Analysis depends on the new system's position in the acquisition process. Experience has shown that this analysis should be emphasized early in the acquisition process.

Typically, the relationships among missions, functions, and design are ambiguously or incompletely specified in this phase. As more information becomes available and design options narrow, the analyst and analysis manager may choose to give less emphasis to this substep.

Functional Requirements Analysis is a means to the end of specifying the system in detail sufficient to support subsequent analyses. If the system design is already detailed, this end may be accomplished.

Of course, experience has also shown that detailed design may have overtaken the resolution of uncertainty in the requirements

phase. If this is the case, Functional Requirements Analysis may assist in resolving uncertainty.

Figure 1B-1 depicts the logic flow for determining functional requirements. As shown in the figure, this substep group contains one substep.

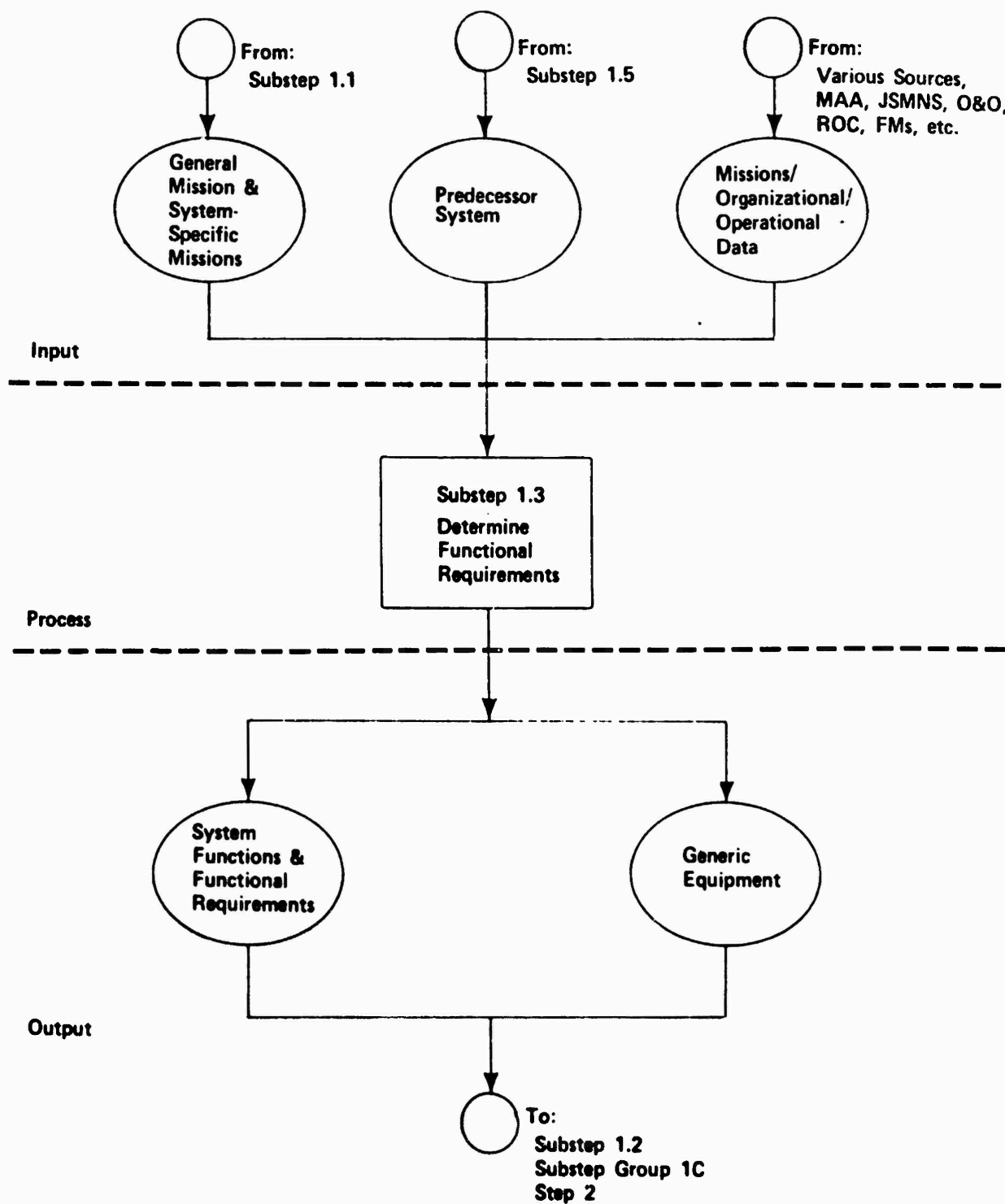

Figure 1.B-1. Functional Requirements Analysis Logic.

Determine Functional Requirements

Objectives

This substep identifies functions necessary to perform battlefield missions assigned to the system under analysis. These functions are analyzed in the context of (1) what conditions are likely to be present on the battlefield and (2) what level of performance is desired. System functional requirements are thus identified.

A system functional requirement is an inherent characteristic or capability which allows the system to perform the required function to the level of desired performance. Describing the functions and the performance requirements constitutes describing the system functional requirements.

When the functional requirements have been sufficiently described, the functions may be allocated to one of the three elements which comprise a system — equipment, people, or information. The definition of what constitutes a "sufficient" description is subjective. Functional requirements need only be detailed enough to support allocating system functions to one of the three system elements.

In HARDMAN, as in the design process, functions are first allocated to equipment/hardware. Generic equipment which performs or supports performance of the function is identified. Functions not allocated to generic equipment remain to be accomplished by the other system elements, people, and information.

Input

Input to this substep from other HARDMAN substeps includes the general mission area context of the system under analysis and

Substep 1.3/Overview

specific system missions from Substep 1.1 (Identify General Mission Requirements) and a description of the Predecessor System from Substep 1.5 (Identify Predecessor System).

Input from other sources includes the most recent Mission Area Analysis (MAA) for the system's mission area; system requirements documents, such as the Justification for Major System New Start (JMSNS) and the statement of Required Operational Capability (ROC); doctrinal publications, such as the how-to-fight field manual series which pertains to the system's mission area; and the system's Operational and Organizational (O&O) Plan.

Product The result of this substep is a list of required system functions, functional requirements, and the generic equipment which supports each function.

Logic By beginning at a high level of abstraction and becoming progressively more detailed, the analyst can generate a hierarchy of missions, functions, and functional requirements which supports allocation of functions to system elements. Figure 1.3-1 depicts the logic flow for determining functional requirements. As shown in the figure, this substep contains three action steps.

Action Steps

Action Step 1: Identify System Functions

Requirements "Functions" can be defined as actions that a system performs to accomplish its mission. A finite set of generic functions applies to

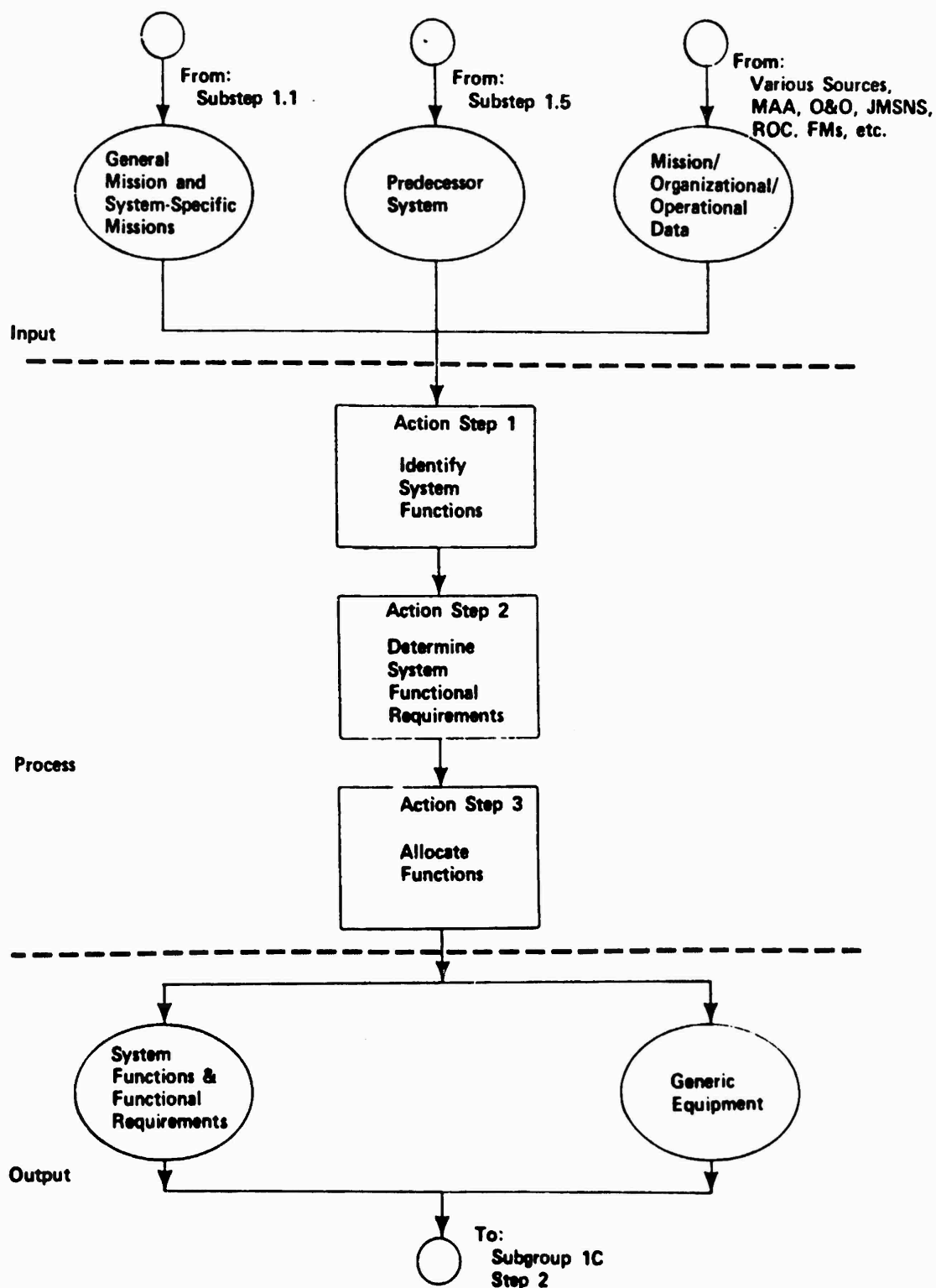

Figure 1.3-1. Determine Functional Requirements logic.

all systems. From the generic set, the analyst must identify the specific functions which apply to the system under analysis. The analyst must also subdivide general, high-level functions into progressively more detailed functions which apply to lower-level system elements.

Objective

In this step, the system functions associated with the system's various missions are identified.

Procedures

1. The analyst must first identify the functions which apply to the system under analysis. The analyst must be careful to distinguish functions from missions and functional requirements. Functions are actions which must be carried out in order to accomplish a mission. Thus, a mission assigned to a system is accomplished through the system's capability to perform certain functions. The functions may be performed by the system as a whole (high-level functions) or by specific combinations of system elements (lower-level functions, or sub-functions).

A functional requirement describes the attributes or capabilities required to be inherent in the system so the function can be successfully performed under operational conditions to the level of performance required. Table 1.3-1 summarizes the distinctions among missions, functions, and functional requirements.

Table 1.3-2 provides a suggested list of generic functions and sub-functions. For a particular mission assigned to the system, the analyst would select from the list those high-level functions needed to perform the mission. After all missions have been reviewed, the analyst will have produced a list of the functions required by the system.

Table 1.3-1. Mission/Function

		Applies to:
Mission	Actions to be accomplished by a command	Forces/units/systems accomplished of systems/single systems)
Function	Actions required to perform missions	System (interaction of all system elements)
Sub-function	Actions required to perform function	Sub-system/components (interaction of particular system elements)
Functional Requirement	Attributes or capabilities required for performance of function/sub-function	Functions and Sub-functions

Table 1.3-2. Generic Functions

Type	Function	Sub-function
Operate —Active	Shoot	Aim Load Fire
	Move	Emplace Transit Navigate Disemplace
	Communi- cate	Transmit Receive
	Command and Control	Sense Process Compare Decide Act

Table 1.3-2. Generic Functions [con't.]

Type	Function	Sub-function
	Intelligence	Sense Process Compare Analyze Disseminate
Operate —Passive	Survive	Attack RAM-D NBC Natural Environment
Support	Battle Support	Supply Maintain Transport

2. For each function, the analyst determines which sub-functions apply. While high-level functions apply to the system as a whole, sub-functions generally apply to a subset of system elements. Progressively subdividing the functions into more detailed and specific sub-functions allows the analyst to make a better choice of generic equipment in Action Step 3. The sub-functions contained in Table 1.3-2 are suggestions. The analyst should describe sub-functions most suited to the system under analysis. If the list in Table 1.3-2 is used, the analyst should note several factors:

- Because functions are primarily active behaviors, verbs describe their sub-functions. The exception is the Survive function, which is a passive behavior. In this case, the sub-functions describe the system's ability to withstand or survive the specific type of condition indicated.

- The Battle Support function occurs largely outside the system boundary. In other words, a system is typically supported by its organization and logistics environment. However, Battle Support and its sub-functions are relevant system functions because the overall ability of the environment to support the system may depend on inherent system characteristics.

For example, Supply may be affected by the system's storage capacity for fuel and ammunition. Transport by any means other than the system's organic capability is affected by the system's size and weight.

- Command/Control and Intelligence consist of similar sub-functions, but the distinction between the two is the traditional one. Command and Control pertains to information on friendly forces, while Intelligence concerns information on the enemy.

3. To accomplish any particular mission, sub-functions from different functional areas will usually be required. The analyst must take care to select only those system functions which fall within the boundary of the system under analysis. It may be necessary to analyze functions which are not included within the system but are essential to system operation. The analyst must distinguish between the two categories.

Example

Situation. The system under analysis is a new howitzer which is part of a larger fire support system. For a typical target engagement, the analyst must identify the functions required of the fire support system and which of these must be present in the howitzer. The requirement for the new howitzer specifies an on-board technical fire control capability, i.e., computing the gunnery solution previously performed in a Fire Direction Center.

B/Substep 1.3

Results. The analyst researches the actions required in a typical target engagement. The results of that research effort are presented in Table 1.3-3.

Table 1.3-3. Functions Example

<u>Required Action</u>	<u>Function</u>	<u>Sub-Function</u>	<u>Within Howitzer?</u>
Detect Target	Intelligence	Sense	No
Identify Target	Intelligence	Process	No
Obtain Target Data	Intelligence	Sense	No
Call For Fire	Communicate	Transmit	No
Accept Call	Communicate	Receive	No
Determine Target Priority	Command and Control	Decide	No
Issue Attack Order	Command and Control	Act	No
Transmit Order/Data	Communicate	Transmit	No
Receive Order/Data	Communicate	Receive	Yes
Obtain Firing Solution	Command and Control	Process	Yes
Apply Firing Solution	Shoot	Aim	Yes
Load Projectile	Shoot	Load	Yes
Load Charge	Shoot	Load	Yes
Fire	Shoot	Fire	Yes
Report Rounds Complete	Communicate	Transmit	Yes
Observe Target Damage	Intelligence	Sense	No
Assess Target Damage	Intelligence	Process	No

Action Step 2: Determine System Functional Requirements

Requirements

A system functional requirement states the attributes or capabilities required to be present in system elements so that each element, and the system as a whole, can accomplish its assigned actions.

A function states what must be done. A functional requirement states under what

conditions the function must be performed and the degree or level of performance required. For each system function, the analyst determines the functional requirements by analyzing the system's operational environment and the performance requirements specified for the new system.

Objective

The purpose of this step is to list the attributes or capabilities that the components of the system require in order to carry out their assigned responsibilities.

Procedures

1. For each function and/or sub-function, the analyst describes two factors which comprise a functional requirement statement:

- Performance Measure: The qualitative description of how the performance of the function will be assessed
- Performance Standard: The quantitative goal or criteria against which performance of the function will be assessed

2. No standard list of performance measures exists for the functions and sub-functions described in the previous action step. Performance measures vary with the system under analysis and the mission area to which it belongs. The analyst may identify potential performance measures and standards for the system under analysis by examining available requirements documentation, such as the JMSNS or the ROC.

Any measure describing the potential performance of the system under analysis should be treated as a performance measure. A function may have more than one performance measure associated with it. Conversely, no performance measures may be associated with a particular function if the function is subsumed in other functions.

3. Performance standards also vary with the system under analysis and the mission area to which it belongs. The mission area context of the system is especially useful to the analyst in determining performance standards if none is available from system documentation.

For example, if the new system requirement is for a direct fire anti-tank weapon in the Close Combat—Light mission area, then for the performance measure of maximum effective range the analyst might assign a standard of 1200 meters if no standard is specified. (This distance is roughly the dividing line for anti-tank weapons assigned to Close Combat—Light versus those assigned to Close Combat—Heavy, although responsibilities overlap.)

Performance standards for the system under analysis may be expressed by referring to existing systems (e.g., improve accuracy 10 percent over current system); by specific quantitative values (e.g., minimum cross-country speed equals 15 miles per hour); or by go/no-go terms (e.g., must fire Copperhead).

4. A functional requirement results when the function and/or subfunction has been assigned both a performance measure and a performance standard. Functions and sub-function provided earlier are at a high level of abstraction, while performance measures and standards are likely to be far more detailed.

The analyst uses information conveyed by the performance measures and standards to develop progressively more detailed descriptions of functions, i.e., those that apply to lower levels of the system. The analyst repeats Action Steps 1 and 2 to insure that the specificity of the terms used for functions, measures, and standards parallel each other.

Example

Table 1.3-4 provides an example of performance measures and standards for a self-propelled howitzer's shoot function.

Table 1.3-4. Performance Measures and Standards

<u>Function</u>	<u>Performance Measure</u>	<u>Performance Standard</u>
Shoot	Response time	Minimum: 15 seconds Maximum: 45 seconds
	Rate of fire	Maximum: 16 rounds/ minute Minimum: 8 rounds/ minute
	Range	Minimum: 1000 meters Maximum: 30,000 meters unassisted Maximum effective: 22,000 meters unassisted
	Terminal Effects	
	—Accuracy	Less than or equal to 20 meters range error
	—Round type	Less than or equal to 10 meters deflection error
	—Target type	DPICM, Copperhead, NBC personnel, tanks

Action Step 3: Allocate Functions

Requirements

When the system and end item functional requirements are identified, the functional requirements are considered to be delineated. The definition of what constitutes delineation of a functional requirement is a subjective one. It depends on the degree to

which the functional requirement supports an allocation of the function to one of the three system components: hardware/equipment, people, or information.

Objective

The objective of this action step is to determine which system functions are accomplished by equipment and which are performed by the system's operators.

Procedures

1. In HARDMAN, as in the system design process, functions are first allocated to equipment/hardware. In constructing a system design responsive to a set of functional requirements, the designer implicitly allocates the remainder of the functions to people and information singly, together, and in contact with the hardware. Allocation to equipment is conceptually easier because it is less abstract.

2. If a Predecessor System exists, it can form the basis for an initial functional allocation. The Predecessor System is helpful to the analyst because, until this point, the analysis has been somewhat abstract. The Predecessor System is a tangible embodiment of functions which have been allocated to equipment.

The analyst consults with the Engineering analyst to determine whether a Predecessor System was identified in Substep 1.5 (Identify Predecessor System). For Predecessor System functions which remain unchanged, the analyst determines the generic type of equipment found in the Predecessor System and allocates the functions to that generic equipment.

3. If no Predecessor System exists, or if the functions required of the new system are substantially different from those of the Predecessor, the analyst must identify generic equipment to which the functions may be allocated. This involves research, logic, and the exercise of professional judgment. The analyst again consults the Engineering analyst for assistance.

4. When all functions have been analyzed and generic equipment have been selected on the basis of functional requirements, the analyst allocates the remaining functions to the system operators and maintainers. Allocation of functions to equipment first allows identification of tasks in Substep 1.10 (Determine Generic Tasks) to be characterized as equipment or non-equipment based. Identification of generic equipment allows identification of generic tasks. As the equipment becomes more specific, so may the task.

Example

The new system is a self-propelled missile launcher. An example of the allocation flow of functions to specific equipment features of the launcher is displayed in Figure 1.3-2.

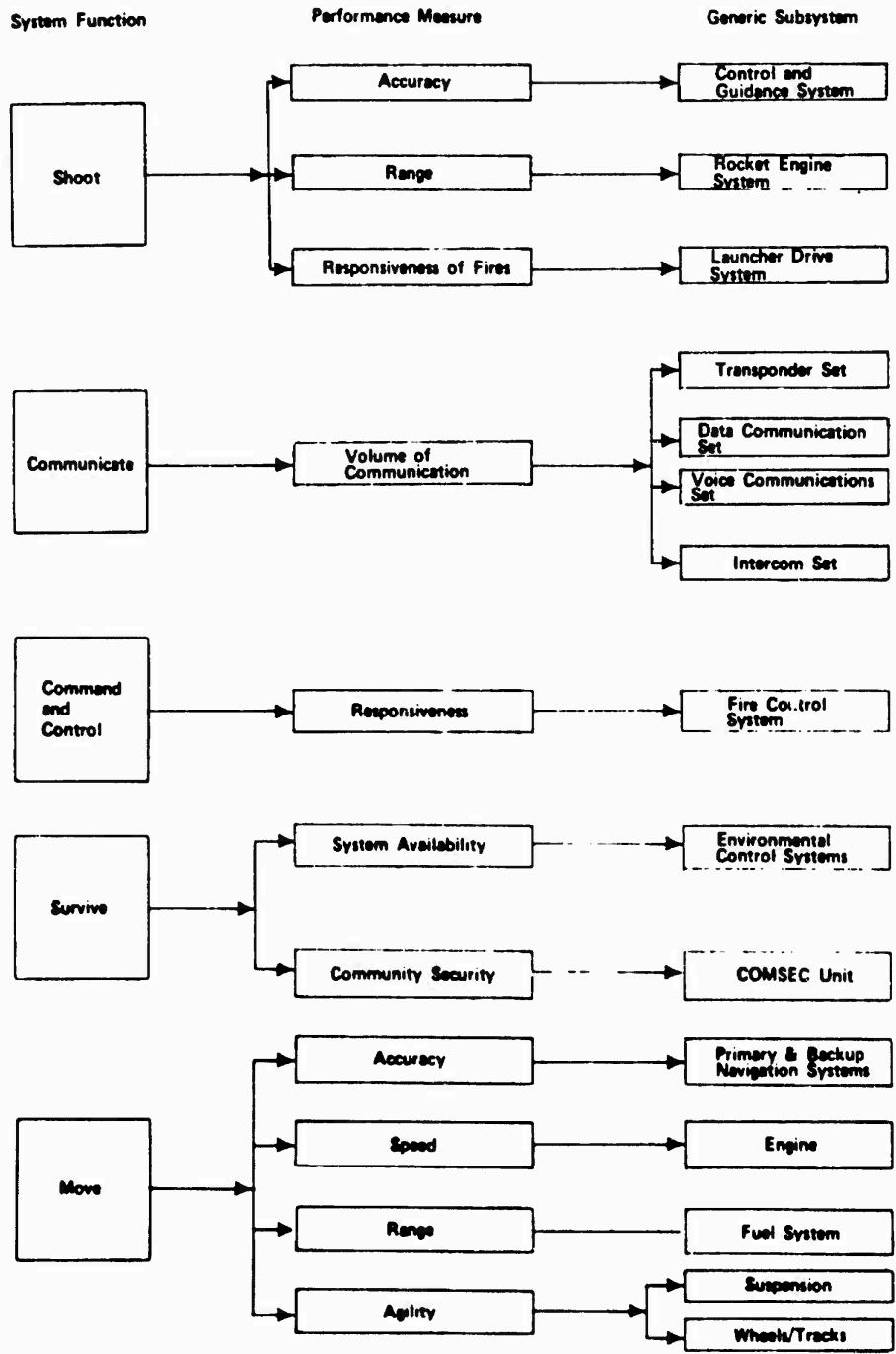

Figure 1.3-2. Functional allocation.

Substep Group 1C

Equipment Comparability Analysis

Overview

Comparability analysis derives systematic estimates of the human resource requirements of emerging weapon systems by extrapolating from the known requirements of similar operational systems and subsystems.

In Equipment Comparability Analysis, the system under analysis is evaluated and interpreted in generic, then more specific design terms. Equipment Comparability Analysis is the analyst's link between knowing what the system must do — its functional requirements — and the specific equipment configurations assigned to do it.

Equipment Comparability Analysis produces specific equipment lists for the Baseline Comparison System (BCS) and each Proposed System alternative. It also produces an index of design differences between the BCS and each Proposed System alternative. These key outputs are critical, as they determine the validity of most subsequent steps and of the analysis as a whole.

The Mission Area Analysis (MAA) phase of the LCSMM culminates the Army's assessment of its mission needs. If a requirement for a new weapon system emerges from the MAA, it results from perceived deficiencies in the Predecessor System, a system currently in the Army inventory.

By definition, the Predecessor System is unable to satisfy the functional requirements of the new system. However, functional requirements information available from an MAA usually focuses on Predecessor System deficiencies, not on the full set of functional requirements identified for the new system. Substep Group 1B, Functional Requirements Analysis, is designed to overcome this lack of information.

Comparability analysis converts the functional requirements of the new system into at least two specific but non-integrated system constructs: the "Proposed System" and the "Baseline Comparison System." These constructs are developed by identifying specific hardware components which can perform system-level functions and tasks. Identified components must also meet the design, operational, and support needs implicit in the functional requirements.

The first of these analytical constructs, the Proposed System, may incorporate technological advances likely to exist before the system's projected Initial Operational Capability date. When the analysis begins, one or more alternative Proposed Systems may be presented. The number presented depends on how many unique solutions were offered by the materiel developer or materiel contractors in response to the Army's statement of mission need and/or system requirement.

The second system construct is termed the Baseline Comparison System (BCS) by MIL-STD 1388-1A (Logistic Support Analysis). The BCS may be a current operational system but is much more likely to be a composite of current operational systems and subsystems. This composite closely approximates the design, operational, and support characteristics stipulated for the developmental system. Components of the BCS may be drawn from the Predecessor System and other comparable existing systems in the DoD/NATO inventory.

Data are collected about the BCS and the Proposed System alternatives for consideration in this and later substep groups. Maturity of the data used for the BCS and the Proposed Systems forms a crucial distinction between the two. To qualify for inclusion in the BCS, a candidate component must have mature data available. Such data are needed to demonstrate the likely MPT impacts under field conditions.

The Proposed System, on the other hand, is defined as less technologically mature. As such, it can include data from tests or engineering estimates. Differences between the two data sets are analyzed to identify design changes between the BCS and Proposed Systems. These design differences form the basis for the distinction between the BCS and Proposed System MPT requirements calculated in subsequent steps.

Logic

Table 1C-1 summarizes the distinctions between the Predecessor, Baseline Comparison, and Proposed Systems. One should not infer that the Proposed System is always developed first and then followed by the BCS. Experience has shown that if Proposed System alternatives have been identified, Equipment Comparability Analysis is somewhat easier to accomplish. From the analyst's point of view, this situation is preferable.

However, definitive statements of system solutions, i.e., the Proposed System alternatives, are not always available, either from a materiel contractor or from the Army agency sponsoring system development. Often, Proposed System alternatives are identified and, upon examination, found lacking in complete, systematic descriptions.

In both cases — where Proposed System alternatives did not exist or were only partially described — the analyst would develop the BCS first. Composite Proposed System alternatives are then developed with information from the BCS, the technological base, and the research and development community at large.

Figure 1C-1 presents an overview of the logic used in Equipment Comparability Analysis.

Table 1C-1. Distinctions Between the Predecessor, Baseline Comparison, and Proposed Systems

<u>System</u>	<u>Satisfies System Functional Requirements?</u>				<u>Data</u>
	<u>What</u>	<u>How Well</u>	<u>Technology</u>	<u>Status</u>	
Predecessor	Majority	Many Deficiencies	Existing - Outdated/Obsolete	Deployed/Obsolete DoD/NATO	Mature
BCS	All	Some Deficiencies	Current - State of the Art	Deployed - DoD/NATO	Mature
Proposed	All	Few Deficiencies	Future - Emerging, Low-Risk	In Development	Immature <ul style="list-style-type: none"> ● Engineering Estimates ● OT/DT Test ● Lab test ● Comparability Extrapolation from BCS Data

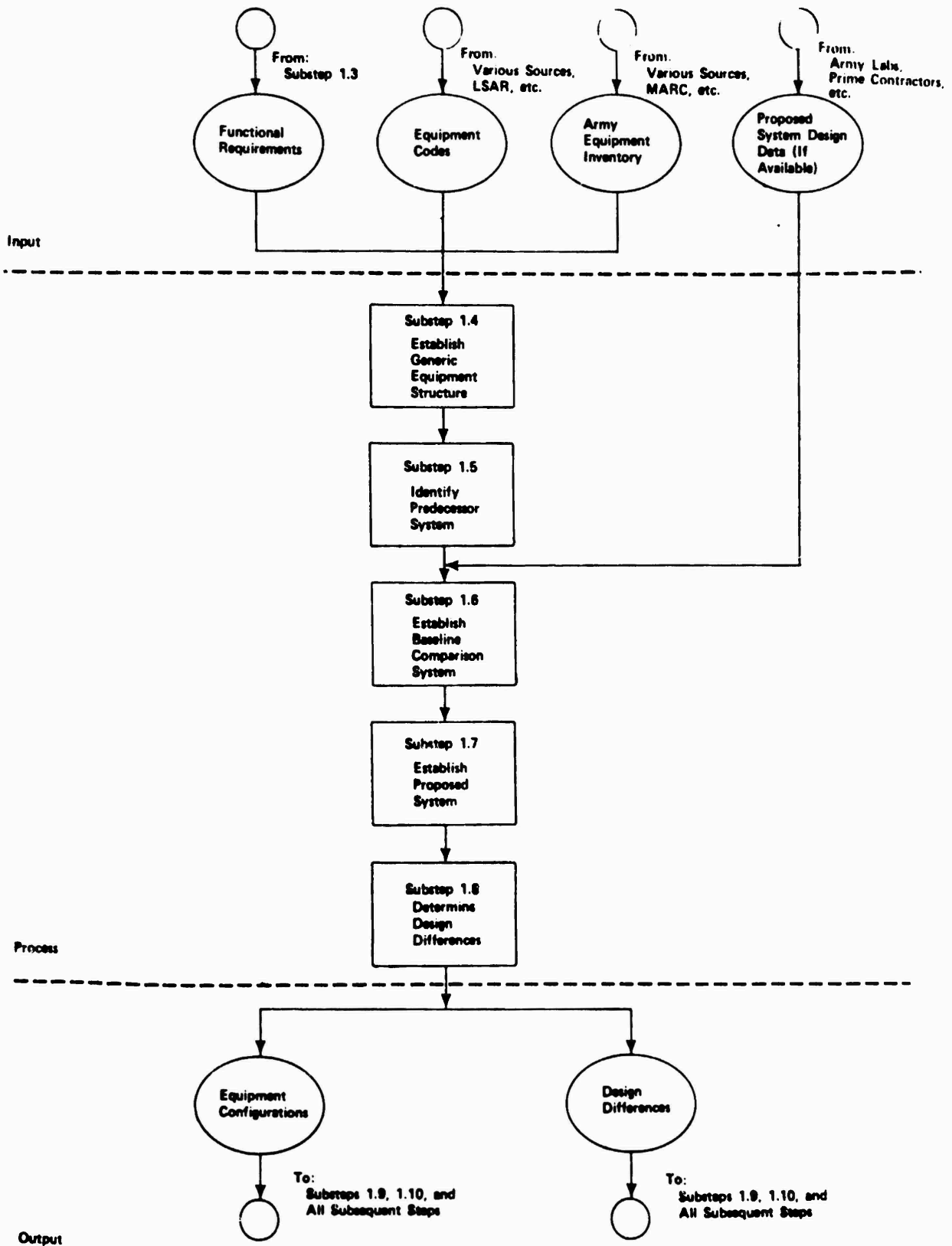

Figure 1C-1. Logic flow for Equipment Comparability Analysis.

Step 1C/Overview

Note that the order in which the five substeps are accomplished tends to be a function of whether Proposed System alternatives are available. Upcoming sections will describe these substeps in detail:

- 1.4 Establish Generic Equipment Structure
- 1.5 Identify Predecessor System
- 1.6 Establish Baseline Comparison System
- 1.7 Establish Proposed System
- 1.8 Determine Design Differences

Establish Generic Equipment Structure

Overview

The materiel aspects of the system under analysis may be represented in a hierarchical manner. The purpose of the hierarchy is to establish a systematic breakdown of the system into its functional groups, basic systems, subsystems, components, assemblies, and parts. When coupled with an indexing mechanism, the hierarchy becomes an analysis tool for comparing the Predecessor, Baseline Comparison, and Proposed System alternatives.

The objectives of this substep are to establish the equipment hierarchy, select an indexing mechanism, and arrange the generic equipment identified by functional allocation in appropriate locations in the hierarchy. The result is a generic equipment structure, which forms the basis for comparisons of Predecessor, BCS, and Proposed System alternatives in the substeps which follow.

Input

Input from HARDMAN Substep 1.3 (Determine Functional Requirements) includes a list of generic equipment which has been allocated to system functions. Other input includes standard indexing mechanisms, such as Functional Group Codes, Work Unit Codes, or Logistics Support Analysis Control Numbers, which may be available from various sources.

Products

The output of this substep is a generic equipment structure constructed by Equipment Identification Code (EIC). The generic structure will be used to develop both the BCS and Proposed System equipment structures.

Logic

The HARDMAN analysis normally progresses from generic to specific. The generic equipment structure is a systematic arrangement of all equipment judged necessary to perform the emerging system's stated functions. The

Substep 1.4/Overview

descriptions of the equipment are generic; that is, they are at a higher level of abstraction than particular examples of the equipment are. Specific examples will be substituted in the development of the BCS and Proposed System equipment structures. The generic equipment structure serves as the basis for those efforts.

Figure 1.4-1 depicts the logic flow for establishing the generic equipment structure. As the figure shows, this substep consists of two action steps.

Action Steps

Action Step 1: Develop Equipment Identification Code [EIC] Structure

Requirements

With the exception of vehicles and support equipment, the Army does not have a standard equipment structure for its systems. Users or analysts are permitted to develop equipment structures which best suit their own purposes. In this substep, the HARDMAN analyst must develop an Equipment Identification Code (EIC) structure for use in the substeps which follow.

Objective

The objective of Action Step 1 is to identify, select, and/or develop an Equipment Identification Code structure for use in other HARDMAN substeps.

Procedures

Military Standard 1388-1A (Logistic Support Analysis) defines a Functional Group Code as a standard indexing mechanism which parcels the weapon system into its functional groups, basic systems, subsystems, components,

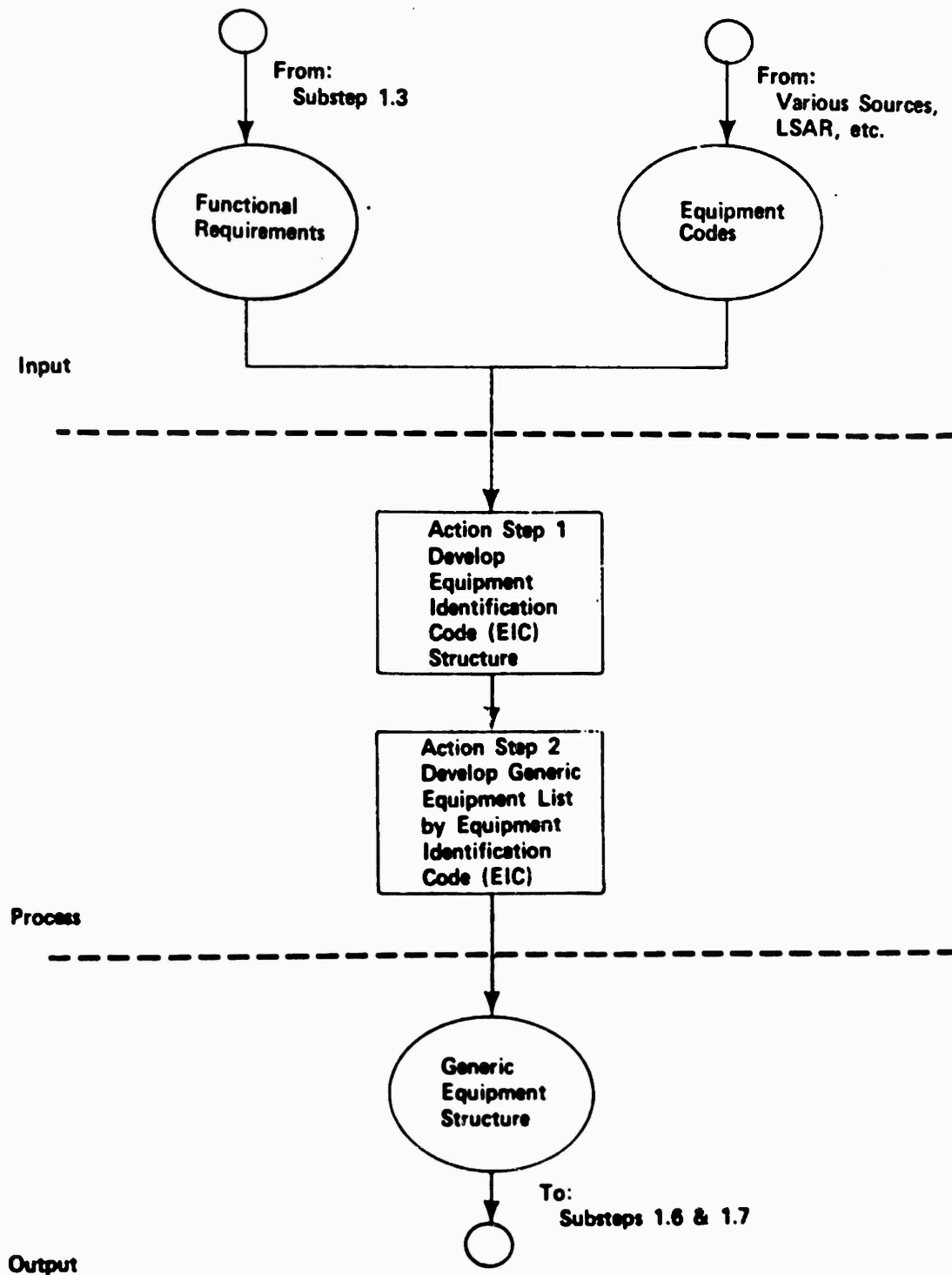

Figure 1.4-1. Logic flow for Establish Generic Equipment Structure.

assemblies and parts. Other codes and terminologies have the same effect as the Functional Group Code.

Among these are the Work Unit Code (WUC), Work Breakdown Structure (WBS), Equipment Identification Code (EIC), and the Logistics Support Analysis Control Number (LCN). All of these terms are used by the military services in different circumstances. HARDMAN employs the most generic terminology, Equipment Identification Code (EIC).

The EIC structure is used to differentiate the various levels of the equipment hierarchy to which it is applied. "Level of indenture" refers to a specific level within this hierarchy. Typically, a system contains five or six levels of indenture. These levels are defined as follows:

- End item — A final combination of end products, component parts, and/or materiel which is ready for its intended use, e.g., Missile, Tank, Aircraft, and Radar.
- System — A complete system within an overall system such as Hydraulic System, Avionics System, Armament System, etc.
- Subsystem — A major portion of a system that performs a specific function in the overall operational function of the system, e.g., the Receiver/Transmitter Set, Radar Set, etc.
- Component/Assembly — A number of parts or subassemblies or any combination thereof joined together to perform a specific function. Within the scope of this document, this term applies to items that cannot be further disassembled or repaired without shop facilities. Examples include signal data converter, antenna, amplifier assembly, etc.

- Subcomponent/Assembly — Those parts or subassemblies comprising the next higher assembly. This level may not be applicable.
- Part — One piece, or two or more pieces joined together, which is not normally subject to disassembly without destruction of designed use.

Figure 1.4-2 provides an example of a system with five levels of indenture. Example EICs are shown in the upper left corner of each rectangle. The precise form of the EIC structure is left to the judgment of the analyst, subject to the condition that codes should be assigned in a manner that allows each item to be uniquely identified as part of its next higher assembly.

A typical structure will have two places for each level of indenture except the end item. The characters may be alpha, numeric, or a combination of those at any level, depending on the characteristics of the system under analysis.

The Army has no standard EIC structure for all systems. Technical Bulletin 750-93-1 (Functional Grouping Codes: Combat, Tactical, and Support Vehicles and Special Purpose Equipment) provides standard Functional Group Codes for combat, tactical and support vehicles, and items of support equipment. The analyst should use these codes if the system under analysis falls into one of these categories.

For other types of systems, the analyst must either identify an existing EIC structure which could serve as the basis for the HARDMAN EIC structure or develop one from a combination of existing EIC structures. Existing EIC structures may be available from Air Force and Navy, as well as other Army sources.

Level

End Item

System

Subsystem

Component/Assembly

Subcomponent/Assembly

Part

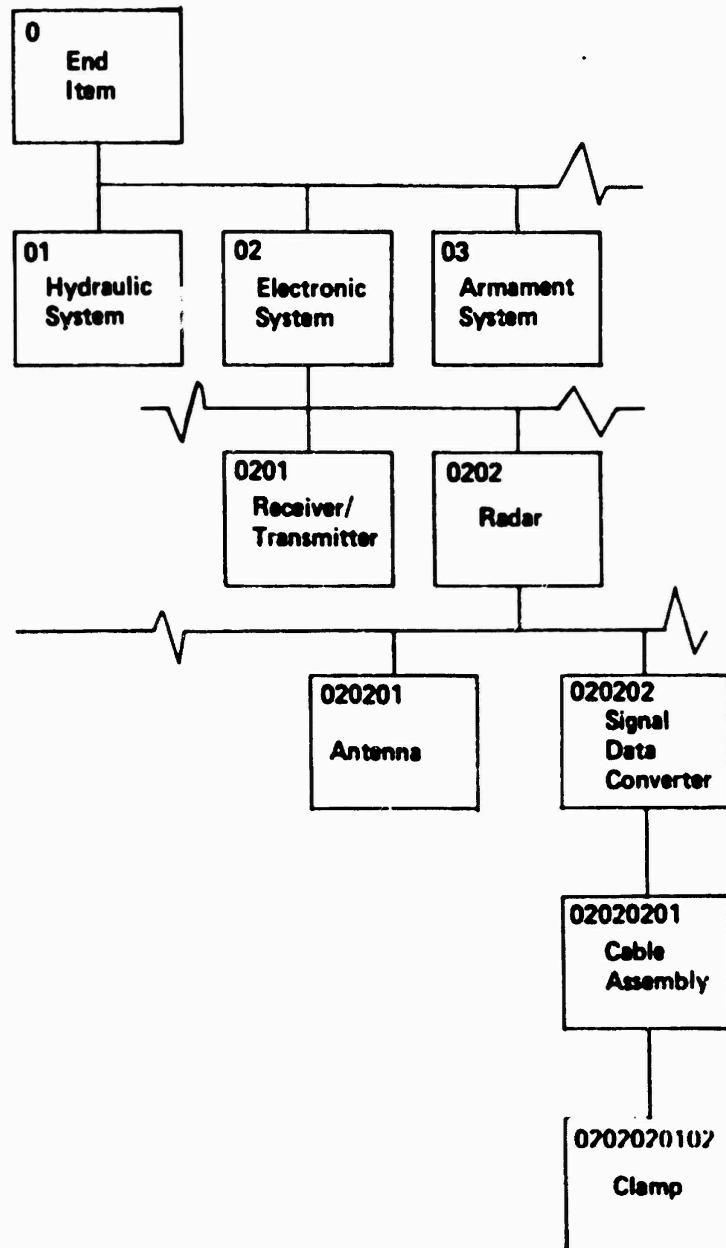

Figure 1.4-2. Levels of indenture.

Examples**Example 1**

Table 1.4-1 provides an example of the assignment of EICs to various levels of indenture.

Table 1.4-1. EIC Assignment Example

Level	EIC	Description
End Item	A	Tank
(Functional) System	A 02	Electronic System
Subsystem	A 02 04	Radar
Component/Assembly	A 02 04 AB	Antenna
Sub-Component/ Assembly	A 02 04 AB 01	Cable Assembly
Part	A 02 04 AB 01 03	Clamp

Example 2

Table 1.4-2 provides EICs from Technical Bulletin 750-93-1 at the functional system, or second, level of indenture.

Example 3

The 11- series of Department of the Army pamphlets provides a useful cross-reference between the subdivisions of a weapon system which are of interest to life-cycle cost analysts and those found in Military Standard 881 (Work Breakdown Structure for Defense Materiel Items). This cross-reference may serve as a starting point for the HARDMAN analyst in developing an EIC structure for systems which cannot be accommodated within the TB 750-93-1 codes. The cross-reference is provided in Table 1.4-3.

Table 1.4-2. TB 750-93-1 Functional Group Codes

01 Engine	50 Pneumatic Equipment (Air compressors, pneumatic motors, etc.)
02 Clutch	51 Water Purification System
03 Fuel System	52 Refrigeration and Air Conditioning Components
04 Exhaust System	53 Laundry Equipment
05 Cooling System	54 Tentage, Equipage, and Special Purpose Clothing Components
06 Electrical System (Engine and vehicular, etc.)	55 Pumps (Exclude engine and special pumps). (See group 2205 for bilge pumps)
07 Transmission	56 Filters, Separators, and Purifiers
08 Transfer Assembly	57 Spray Equipment Components
09 Propeller and Propeller Shafts	58 Sanitation and Fumigation Equipment Components
10 Front Axle	59 Water Supply Systems
11 Rear Axle	60 Steam Boilers, Water Heaters, Heating Units, Burners (Exclude heaters in groups 22, 23 and 59)
12 Brakes (Other than special purpose)	61 Gas Generating Equipment Components
13 Wheels and Tracks	62 Illuminating Equipment (Other than electrical)
14 Steering	63 Control Panels and Control Compartments
15 Frame, Towing Attachments, and Drawbars	64 Ventilating Fans and Blowers (Special purpose)
16 Springs and Shock Absorbers	65 Reproduction Equipment Components
17 Railway Car Body and Underframe	67 Precision Instruments and Systems, Mechanical Electrical, or Electronic (See group 34 for fire control)
18 Body, Cab, Hood, and Hull	68 Warning, Scanning, and Signaling Devices and Navigational Instruments (Land, air, and water)
19 Turret	69 Sawmill Components
20 Hoist, Winch, Capstan, Windlass, Power Control Unit, and Power-Take-Offs	70 Machine Tools and Related Equipment
21 Bumpers, Guards, and Marine Fenders	71 Snow Removal, Mowing, and Sweeping Equipment Components
22 Body, Chassis or Hull, and Assembly Items	72 Dispensing and Servicing Equipment Components
23 Hydraulic Lift Components (Exclude tractor, bulldozer lifts)	73 Concrete and Asphalt Equipment Components (Mixers, pavers, spreaders, duct collectors, finishers, etc.)
26 Tools and Test Equipment	74 Crane, Shovels, and Earth Moving Equipment Components
29 Auxiliary Generator and Engine and Controls (Special purpose)	75 Conveying, Feeding, Crushing, Screening, and Washing Equipment Components
30 Elevators, Special Purpose (Hydraulically operated)	76 Fire Fighting Equipment Components
33 Special Purpose Kits	77 Musical and Tonal Instruments
34 Armament and Sighting and Fire Control (Electric/Electronic) Material	80 Storage Equipment Components
35 Pulleys, Belts, Shafts (Not related to other functional groups)	84 Nuclear Components (Primary system)
39 Searchlight and Electrical Illuminating Equipment	85 Nuclear Components (Secondary system)
40 Electric Motors and Generators (Other than engine accessories)	86 Nuclear Components (System controls and instrumentation)
42 Electrical Equipment (Not contained in other functional groups)	87 Nuclear Components (Auxiliary equipment and plant accessories)
43 Hydraulic, Fluid, Air, and Vacuum Systems (Exclude brake system)	90 Maintenance and Operating Supplies
44 Welding, Metalizing, Metal Heating, and Plating Equipment	91 Chemical, Biological, and Radiological (CBR) Equipment
45 Office Machinery, Equipment, and Furniture (Include household furniture)	95 General Use Standardized Parts
46 Repair Equipment (Shoes, clothing, textile)	99 Parts Peculiar
47 Gages (Non-Electrical), Weighing and Measuring Devices	
48 Food Preparation Equipment (Mobile and field)	

Table 1.4-3. LCC/MIL-STD 881 Cross References

SPECIFIC GENERIC	AIRCRAFT SYSTEMS		MISSILE SYSTEMS		SURFACE VEHICLE SYSTEM		ELECTRONIC SYSTEM		ORDNANCE SYSTEM	
	LIFE CYCLE COST MATRIX	MIL STD 881	LIFE CYCLE COST MATRIX	MIL STD 881	LIFE CYCLE COST MATRIX	MIL STD 881	LIFE CYCLE COST MATRIX	MIL STD 881	LIFE CYCLE COST MATRIX	MIL STD 881
1 FRAME	AIRFRAME	AIRFRAME	AIRFRAME	MISSILE INTEGRATION & ASSEMBLY	MULL, TURRET & SUSPENSION	BODY/CAR MULL/FIAME TURRET ASSEMBLY	AUTOMATIC DATA PROCESSING SUBSYSTEM	ADP EQUIPMENT	CARRIAGE	CARRIAGE LAUNCH SYSTEM INTEGRATION & ASSEMBLY
2 PROPULSION	POWER PLANT	POWER PLANT	PROPULSION	PROPULSION	POWER PACKAGE	POWER PACKAGE DRIVE TRAIN	DATA DISPLAY SUBSYSTEM	DATA DISPLAYS		
3 GUIDANCE AND CONTROL COMBO EQUIP	COMMUNICA TION, NAVIGA TION, AUTO GUIDANCE	COMMUNICA TION, NAVIGA TION, AUTO GUIDANCE CONTROL	MISSILE GUIDANCE & CONTROL	MISSILE GUIDANCE & CONTROL EQUIP	COMMUNI CATIONS EQUIPMENT	COMMUNICA TIONS & NAVIGATION EQUIPMENT	COMMUNICA TIONS SUBSYSTEM	COMMUNICA TIONS	COMMUNICA TIONS EQUIPMENT	
4 FIRE CONTROL	FIRE CONTROL	FIRE CONTROL	FIRE CONTROL & OTHER COMBO EQUIPMENT	SURVEILLANCE, ROCKET & TRACKING SENSORS LAUNCH & GUIDANCE CONTROL	FIRE CONTROL	FIRE CONTROL	SENSOR SUBSYSTEM	SENSORS	FIRE CONTROL	FIRE CONTROL EQUIPMENT
5 ARMAMENT	ARMAMENT	ARMAMENT DELIVERY EQUIPMENT, AUX ARMORS DEL EQUIP	LAUNCHER	LAUNCHER EQUIP COMMAND & INTEGRATION & ASSEMBLY	ARMAMENT	ARMAMENT	AUX EQUIP SUBSYSTEM	AUX EQUIP	LAUNCHER	LAUNCHER
6 PAYLOAD	ARMAMATION		MISSILE PAYLOAD	LAUNCHED PAYLOAD SHROUD	ARMAMATION				COMPLETE ROUND	COMPLETE ROUND (LEVEL II)
7 TO BE SPECIFIED	SPECIFIED		SPECIFIED		SPECIFIED		SPECIFIED		SPECIFIED	
8 PECULIAR SPT EQUIP	PECULIAR SPT EQUIP	PECULIAR SPT EQUIP	PECULIAR SPT EQUIP	PECULIAR SPT EQUIP	PECULIAR SPT EQUIP	PECULIAR SPT EQUIP	PECULIAR SPT EQUIP	PECULIAR SPT EQUIP	PECULIAR SPT EQUIP	PECULIAR SPT EQUIP
9 COMMON SPT EQUIP	COMMON SPT EQUIP	COMMON SPT EQUIP	COMMON SPT EQUIP	COMMON SPT EQUIP	COMMON SPT EQUIP	COMMON SPT EQUIP	COMMON SPT EQUIP	COMMON SPT EQUIP	COMMON SPT EQUIP	COMMON SPT EQUIP
10 OTHER	OTHER	AS REQUIRED FOR 100% COVERAGE	OTHER	AS REQUIRED FOR 100% COVERAGE	OTHER	OTHER	OTHER	AS REQUIRED FOR 100% COVERAGE	OTHER	AS REQUIRED FOR 100% COVERAGE

C/Substep 1.4

Action Step 2: Develop Generic Equipment List by Equipment Identification Code

Requirement The analyst lists all equipment identified in Substep 1.3 according to the EIC structure developed in Action Step 1.

Objective The objective of this substep is to create an equipment configuration that mirrors the functions identified in Substep 1.3. This equipment structure will be used to develop and compare equipment structures in the substeps which follow.

Procedures Substep 1.3 (Functional Requirements Analysis) provides a list of generic equipment to which the functional requirements have been allocated. The analyst sorts these and arranges them in the appropriate positions in the EIC structure.

Some equipment may be able to satisfy more than one function, however, only one will be in the generic equipment structure. Conversely, some equipment will be required by the generic equipment structure that is not directly related to the functional requirements but is implicit in the nature of the type of system identified.

The analyst proceeds by levels of indenture. Once a generic equipment structure is established below the end-item level, the analyst proceeds to the next level. In consultation with the Functional Requirements analyst, the analyst refines the descriptions of generic equipment to provide the greatest detail possible.

The generic equipment structure will support a lower level of indenture as more decisions and/or information are forthcoming. As the generic equipment structure is taken to a lower level of indenture, the analyst must be careful to remain general in definition and not specific in equipment selection.

For instance, "engine" may become "engine, diesel" and even "engine, diesel, 500-horsepower" but not "engine, diesel, Detroit Diesel Allison 8V71T." The choice of specific equipment will occur in Substeps 1.5, 1.6, and 1.7, where the Predecessor, BCS, and Proposed Systems, respectively, are established.

Example

Situation. Functional Requirements Analysis has established the new system must be a tracked vehicle. The analyst must develop a generic equipment structure for the track functional system to the third level of indenture.

Results. The analyst consults TB 750-93-1 and obtains the following results:

EIC	Description
A	End Item
A 13	Track System
A 13 01	Suspension Assembly
A 13 02	Track Support Rollers and Brackets
A 13 03	Track Idlers and Brackets
A 13 04	Track Drive Sprockets
A 13 05	Track Assembly

This page intentionally left blank.

Substep 1.5/Overview

Identify Predecessor System

Overview

The Mission Area Analysis (MAA) phase of the LCSMM culminates the Army's assessment of its mission needs. If a requirement for a new weapon system emerges from the MAA, it results from perceived deficiencies in the Predecessor System, a system currently in the Army inventory.

The MAA determines whether the Predecessor System should be replaced completely or in part. Replacement of the Predecessor is usually advocated in the event of: excessive operation and/or support costs, a perceived enemy threat to which the Predecessor is unresponsive, an opportunity to incorporate technological advances, or any combination of the above.

Three types of system acquisition can arise when the new system requirement is compared with the Predecessor System. These acquisition types are called a Replacement System, a System Replacement, or a New System. The distinctions among the three types are important because, as Table 1.5-1 shows, each has different implications for a HARDMAN application.

Objective

The objective of this substep is to identify the weapon system (or systems) currently in the Army inventory which will be replaced by the new system. The currently deployed system is termed the Predecessor System.

Input

Input from previous HARDMAN substeps includes a list of system functional requirements from Substep 1.3 (Determine Functional Requirements). Also required are system descriptive documents such as the Operational and Organizational Plan (O&O) and the Required Operational Capability (ROC).

Table 1.5-1. Acquisition Types

Type Acquisition	Characteristics	Impacts	Predecessor	Replaced By:	EXAMPLE
Replacement system	<ul style="list-style-type: none"> ● Replaces 1950-60 version with 1980-90 version 	<ul style="list-style-type: none"> - Organizational change: some/slight - Personnel: Redistribute - Training: Revise - Doctrinal change: some/slight 	M60 A1/A3	M1	
System replacement	<ul style="list-style-type: none"> ● Replaces old technology; broadened operation and organizational needs 	<ul style="list-style-type: none"> - Organizational change: major revisions - Personnel: Retrain crews/redistribute - Doctrinal change: major revisions 	M109 A2/A3	HIP	
New system	<ul style="list-style-type: none"> ● A new capability: Respond to new threat 	<ul style="list-style-type: none"> - Organizational change: establish organizational structures - Personnel: Establish MOS structures - Training: Acquire/develop training - Doctrinal change: Establish employment doctrine 	None	RPV	

Products

If a Predecessor System exists, results of this substep include a Predecessor System equipment structure. This equipment structure incorporates Equipment Identification Codes (EICs) to facilitate comparison with other equipment configurations in the analysis.

Logic

A Predecessor System is identified for two reasons. The first is to assist the HARDMAN analyst. The existence of a Predecessor system greatly simplifies the analyst's task in Mission and Functional Requirements Analysis, as the Predecessor System establishes the initial operational and organizational context for the new system. The Predecessor System is also the physical embodiment of functions matched to equipment. This serves as a reference during functional allocation.

The HARDMAN analyst also uses the Predecessor System equipment in developing the Baseline Comparison System (BCS). Components of the BCS may be drawn from the Predecessor System and other comparable existing systems in the DoD/NATO inventories.

The degree to which Predecessor System components are incorporated into the BCS depends on whether the developmental system represents a Predecessor upgrade or a totally new system. In a Predecessor upgrade, some Predecessor and some supplemental components are found in the BCS. In a development with no Predecessor, the BCS is derived entirely from other systems with similar components.

The second reason for identifying the Predecessor System is to identify the quantity and quality of manpower, personnel,

and training (MPT) resources which may be available to support the requirements of the developmental system. Since the Predecessor System is currently in the Army's inventory, it has MPT resources associated with it. These resources are what is typically termed the "footprint" within which the MPT requirements of the developmental system are often required to fit.

Figure 1.5-1 depicts the logic flow for identifying the Predecessor System. As the figure shows, this substep entails a single action step.

**Action Step
Requirement**

The analyst identifies the weapon system or systems in the Army inventory currently performing the functions to be required of the Proposed System.

Objective

The objective of this action step is to identify a currently existing system which satisfies a majority of the system functional requirements.

Procedures

The analyst investigates the existence of a weapon system or systems which satisfy these two criteria:

Criterion 1. The system must currently be in the Army inventory of fielded systems.

Criterion 2. The functions which the system performs must be those identified for replacement or improvement by the developmental system.

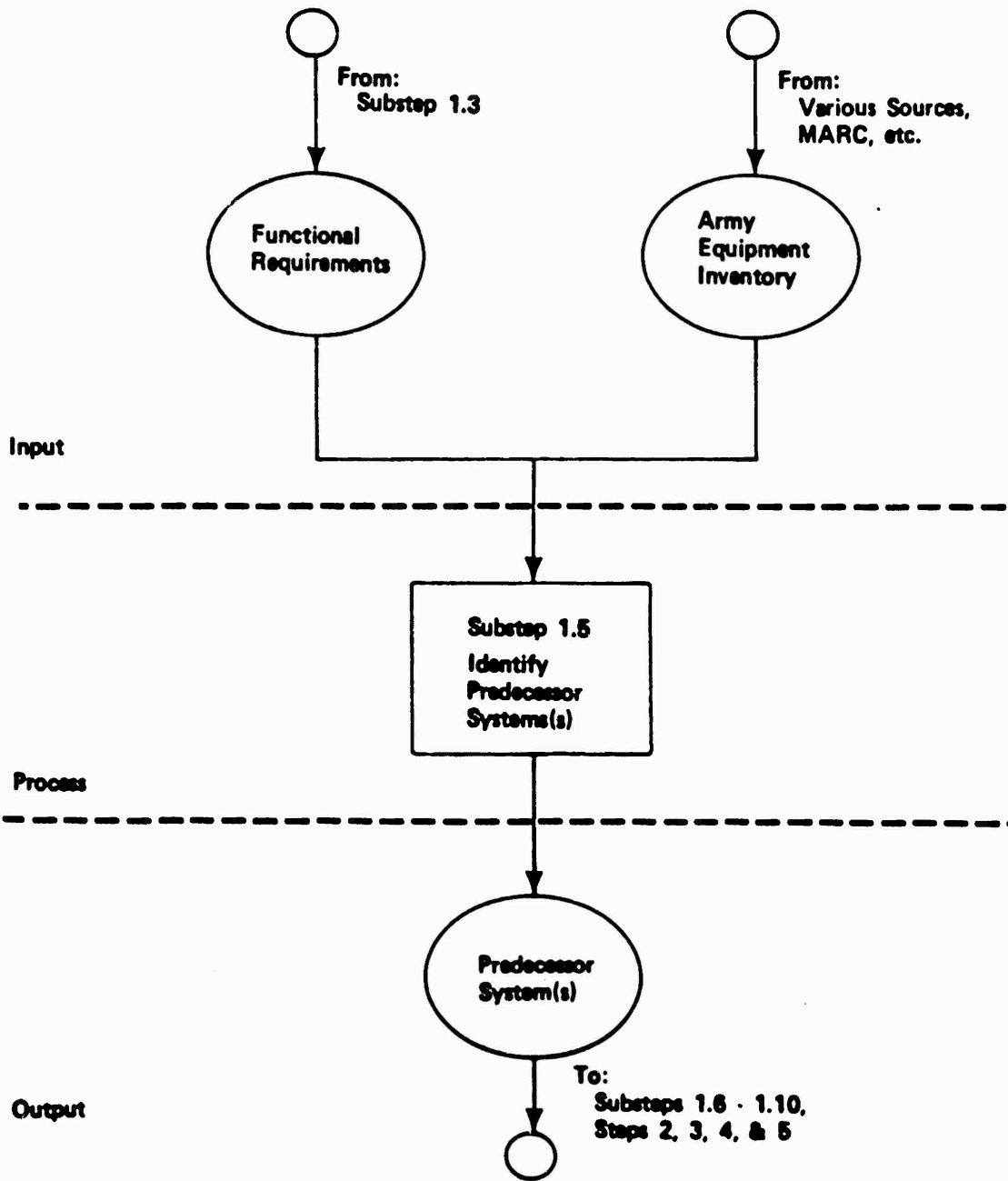

Figure 1.5-1. Logic flow for Identify Predecessor System.

C/Substep 1.5

The system which best satisfies both criteria should be selected as the Predecessor System.

The analyst can often identify the Predecessor System from the Mission Area Analysis (MAA). The MAA compares the projected mission requirements against the ability of current systems to satisfy the requirements. These current systems are potential Predecessor Systems.

Occasionally, a new system is developed to replace more than one current system. In this case, each current system is considered a Predecessor System for resource comparison purposes; the MPT requirements of the new system will be compared to each current system under the specific organizational context of the current system. In developing the BCS and Proposed System equipment structures, the components of all current systems are examined for possible inclusion.

The analyst must distinguish between the Predecessor System and the components which comprise it. Only the Predecessor System is of interest to the HARDMAN analyst for resource comparison purposes, while any and all existing components, from the Predecessor System or other weapon systems, may be used in constructing the BCS and Proposed System equipment structures. Even if no system qualifies as a Predecessor, the analyst may use components from the rejected candidates in constructing the BCS and Proposed System equipment structures.

Example

Table 1.5-1 above provides examples for each acquisition type where a Predecessor System is involved.

Substep 1.6/Overview

Establish Baseline Comparison System

Overview

As discussed earlier, the HARDMAN methodology's power and validity are derived primarily from its use of comparability analysis. A HARDMAN comparability analysis is performed by means of a Baseline Comparability System (BCS), as required by MIL-STD-1388-1A (Logistics Support Analysis). The BCS is not intended to be a fully integrated design. Instead, it provides a tool for comparability analysis.

The BCS, a composite of similar existing systems and subsystems, is developed to resemble the Proposed System. Here, "similar" means that BCS components (1) perform functions required of the Proposed System and (2) are similar in design to the Proposed System. The Proposed System design includes conceptual as well as existing features of the desired hardware, software, and man-machine interface design.

The existing systems and subsystems comprising the BCS normally reside in Army, DoD, NATO, or civilian inventories. Criteria for BCS equipment selection, including those stated in the above paragraph, are fully discussed in the action steps below.

Objectives

The purpose of this substep is twofold: (1) to establish and describe a BCS for use in HARDMAN comparability analyses and (2) to collect BCS MPT-related data which will be the bases of new system MPT requirements projections.

Input

Input from earlier HARDMAN substeps includes the system functional requirements developed in Substep 1.3, the generic equipment structure generated in Substep 1.4, and the Predecessor System equipment identified in Substep 1.5. In most cases, some information will be available on the Proposed System design, whether it consists of design concepts, preliminary designs, or more detailed designs.

Substep 1.6/Overview

In these cases, the available Proposed System information is input to BCS selection. Therefore, Substep 1.7 (Establish Proposed System) may begin before Substep 1.6 is completed. Finally, information on potential BCS candidate equipment must be available in order to make BCS equipment selections.

Products

This substep produces a BCS equipment list (hardware and software) for use in equipment comparability analyses conducted throughout the remaining HARDMAN processes. The equipment must be specified only to the level of detail required to satisfy the study objectives. This substep also requires collection of MPT-related data for all BCS equipment.

Logic

Figure 1.6-1 represents the logic flow for establishing the BCS. As shown in the figure, four action steps are required in this substep. The first three action steps correspond to the application of three BCS equipment selection criteria. Note that the criteria are not applied to the BCS as a whole but rather to a specific item of equipment at an appropriate level of indenture in the generic equipment structure.

Typically, HARDMAN is performed at the subsystem level of indenture, plus or minus one level. When all the positions in the generic equipment structure have been assigned to an item of equipment that has satisfied the BCS selection criteria, then the BCS system-level equipment structure has been established.

The first three action steps are of equal importance in establishing the BCS and may be performed concurrently rather than sequentially. Criteria (Action Steps) 1 and 2 are logical requirements of the HARDMAN methodology, while Criterion 3 is a practical requirement for generating meaningful HARDMAN products.

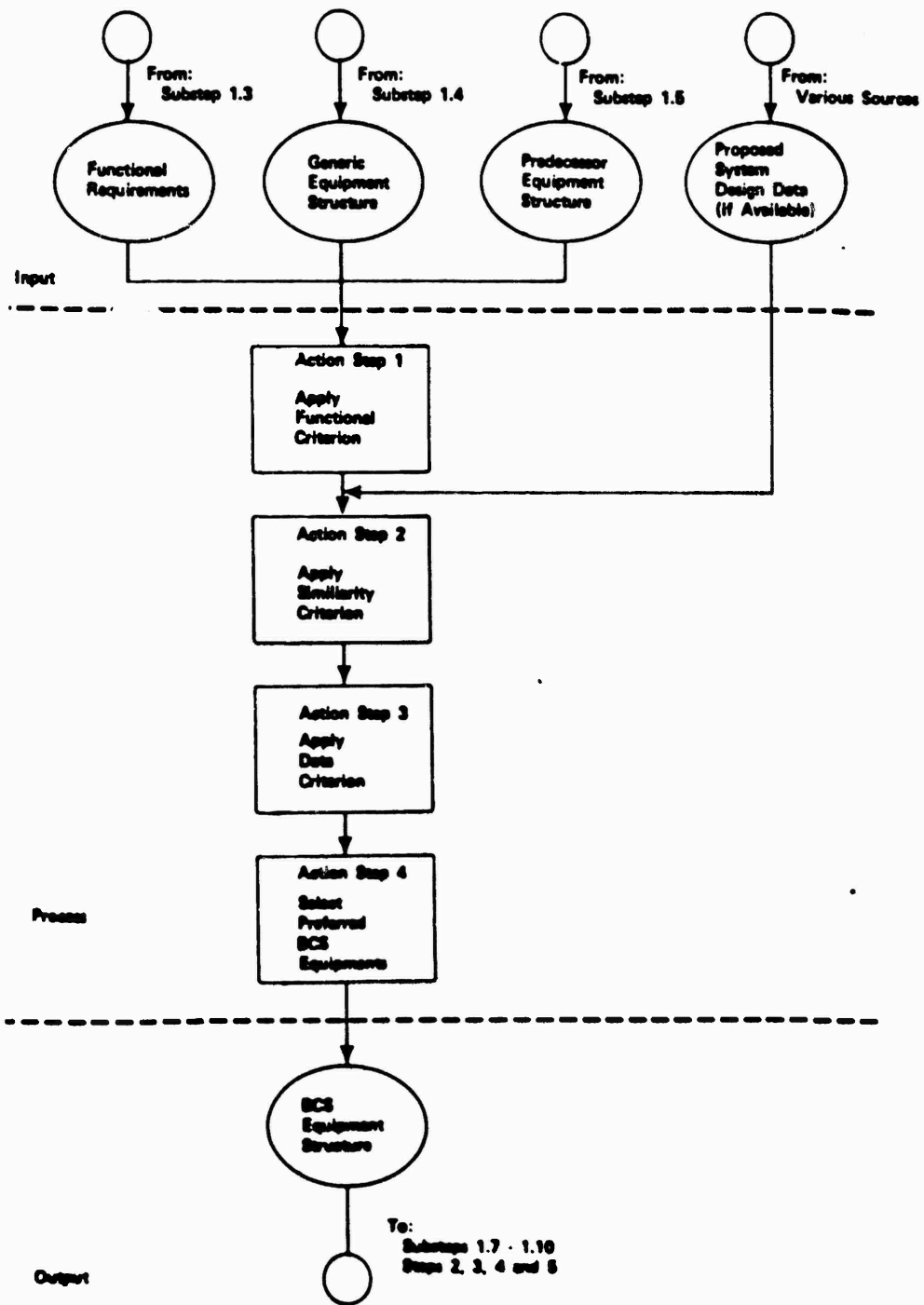

Figure 1.6-1. Logic flow for Establish BCS.

C/Substep 1.6

ACTION STEPS

Action Step 1: Apply Functional Criterion

Requirements

In Substep 1.3, the specific new-system functions required to perform the stated mission were determined. Functional qualifiers, or performance goals, were defined to express how well (how accurately, how quickly, with what endurance, etc.) the functions are required to be performed. Functional requirements, along with the performance goals, drive the Proposed System design.

Similarly, functional requirements drive the determination of the BCS. Functional capability is one of the three criteria for BCS equipment selection. BCS equipment must perform new-system functions. However, since the BCS only contains existing systems and subsystems, BCS equipment will not necessarily meet all of the performance goals established for the Proposed System.

Objective

The objective of this step is to insure that BCS equipment performs one or more new system functions and approach new system performance requirements.

Procedures

Action Step 1 is performed for every HARDMAN application. The analyst uses the system functional requirements and the generic equipment list as input for this procedure. The analyst uses the criterion stated below to first identify, then evaluate the suitability of candidate equipment for inclusion in the BCS.

Criterion. BCS candidate equipment must satisfy the functional requirements of the particular position in the generic equipment structure and approach or meet new system performance requirements.

The analyst first uses the criterion to identify potential BCS candidate equipment in existing Army, DoD, NATO, and civilian inventories. If a Predecessor System exists, it will serve as a potential source for BCS candidate equipment. All other equipment identified by the analyst is referred to as "supplemental equipment." Even when a Predecessor exists, the BCS as a system is almost invariably a combination of Predecessor and supplemental equipment.

The generic equipment list, developed from the system functional requirements, identifies the types of equipment required and/or desired to perform all system functions. Within each generic equipment category, several specific existing pieces of equipment are likely to be identified.

The analyst must determine which of the several items best meets the performance requirements specified for the new system. This becomes the preferred choice for eventual incorporation into the BCS. However, because this choice may not satisfy the remaining BCS selection criteria, it is important to retain for further consideration those items which have satisfied the strict functional portion of the criterion.

As a practical matter, application of the functional criterion is an iterative process. The analyst continually refines and narrows his list of potential equipment in light of functional and performance information that can be collected on each item. When the range of functionally suitable items has narrowed to manageable proportions (in the analyst's judgment), the second portion of the criterion may be applied to yield the list of BCS candidate equipment. Figure 1.6-2 depicts the iterative nature of the process.

C/Substep 1.6

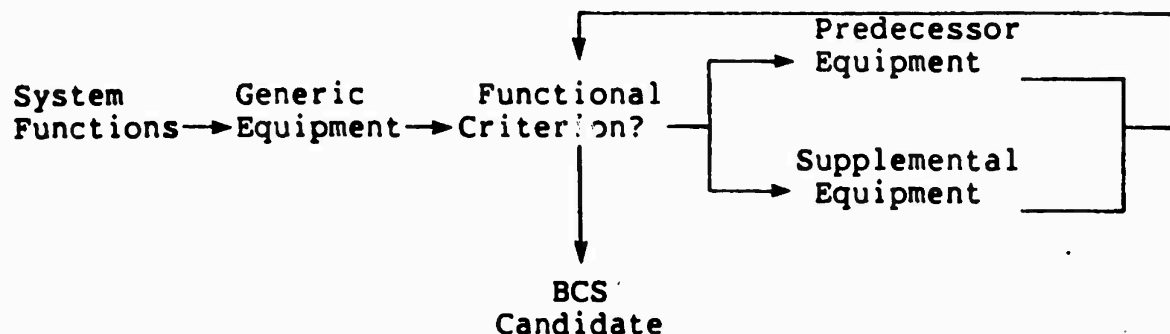

Figure 1.6-2. Iterative nature of functional criterion application.

Examples

Example 1

Situation. A new, advanced attack helicopter is required to have a head-up display (HUD) which provides a horizontal view of the terrain and air space ahead of the vehicle as well as 70 to 80 degrees to either side of the line of flight. FLIR/EO/Radar pickup of potential targets and friendly vehicles and/or equipment will be superimposed on the horizontal scene.

IFF intelligence will allow labelling of the superimposed objects as friendly, unknown, or enemy. The range to specific enemy targets can be added to the display by operator/pilot request through an an interactive keyboard. Table 1.6-1 summarizes the functions and performance requirements of the subsystem.

Table 1.6-1. HUD Functional/Performance Requirements

<u>Functional</u>	<u>Performance</u>
Horizontal sweep view	Survey terrain and airspace 70 to 80 degrees either side of aircraft
Superimpose observed targets	Ground targets (vehicles and equipment), air targets
Accepts multiple sensor inputs	Sensor types: Forward-looking Infra-red Radar (FLIR), Electro-optical (E-O), conventional radar
Label targets	Identification, Friend or foe (IFF) Range to target

C/Substep 1.6

Results. Based on the functional and performance requirements, the analyst identifies the following candidates for the BCS:

Table 1.6-2. BCS Candidates

<u>Head-Up Display Nomenclature</u>	<u>Description</u>	<u>Used on</u>
AN/AVQ-20	Head-up display in Air Force F-15 fighter serviced by computer from multimode radar AN/APG-63 input; air-to-air targets only	F-15
Kaiser-built Display	Head-up display in Air Force F-16 aircraft serviced by Sperry computer from AN/APG-66 radar and television (E-O) inputs; air-to-air only	F-16
AN/AVQ-28	Head-up display in F/A-18 serviced by computer from multimode AN/APG-65 radar set and AN/ASQ 173 laser detector/tracker/camera set; has range capability, look-down capability for ground targets	F/A-18
Integrated Helmet Display Sight System (IHDSS)	Head-up similar display in helmet-mounted monocle; has FLIR, E-O, and radar images, range capability, air-to-ground and air-to-air capability	AH-64A

The analyst determines that the candidate components satisfy the functional criteria as follows:

Table 1.6-3. Functional Criteria Satisfied

<u>Head-up Display Nomenclature</u>	<u>Horizontal Sweep View</u>	<u>Superimpose Observed Targets</u>	<u>Accept Multiple Input</u>	<u>Label Targets</u>
AN/AVQ-20	X	X	X	X
Kaiser-built display	X	X	X	
AN/AVQ-28	X	X	X	X
INDSS	X	X	X	X

The analyst concludes that all candidates except the Kaiser-built model satisfy the requirement.

Example 2

Situation. Continuing with the situation in Example 1, the analyst must now apply the performance portion of the functional criteria.

C/Substep 1.6

Results. The analyst obtains the following results:

Table 1.6-4. Applying Performance Criteria to BCS Candidates

<u>Performance Requirements</u>	<u>AN/AVQ-20</u>	<u>Kaiser-built F-16</u>	<u>AN/AVQ-28</u>	<u>IHDSS</u>
Terrain sweep			X	X
Air sweep	X	X	X	X
70-80 degree	X	X	X	X
Ground targets			X	X
Air targets	X	X	X	X
FLIR				X
E-O		X	X	X
Radar	X	X	X	X
Label IFF	X		X	X
Label range			X	X

After applying the functional criterion, the analyst concludes that the IHDSS is the preferred candidate, followed closely by the AN/AVG-28.

Action Step 2: Apply Similarity Criterion

Requirements

If Proposed System alternatives are available, it is important for BCS equipment to resemble the Proposed System's design as closely as possible. Specific and detailed Proposed System alternatives are valuable to the HARDMAN analyst because they are presumed

to be the result of thorough technical and engineering investigations by materiel contractors. The effort required is considerably more than the HARDMAN analyst can typically afford.

Moreover, materiel contractors are presumed to have provided integrated solutions to the system requirements stipulated by the Army. It is these solutions which are being "proposed" to the Army for acquisition. To best assist the Army in deciding among the various Proposed System alternatives or to fairly evaluate the technical merits of a single Proposed System alternative, the BCS should reflect the technology incorporated by the alternatives at hand.

Objective

The objective of this action step is to insure that the BCS candidate equipment identified previously is similar in design to available Proposed System alternatives.

Procedures

The analyst uses the following criterion to evaluate the BCS candidate equipment identified in the previous Action Step.

Criterion. The preferred BCS equipment is that most similar in design to available Proposed System alternatives. "Design" refers to the hardware, software, and man-machine interface aspects of the system under analysis. Similarity should be judged by the best overall combination of the following factors:

- weight
- volume
- layout/arrangement of component parts
- type of technology incorporated
- sophistication of technology incorporated
- environment (e.g., ground vs. air)

C/Substep 1.6

Additional information, such as support system characteristics and force structure considerations, may also be used by the analyst, although that information is less important. Thus, this action step requires the collection of information on BCS candidate equipment hardware/software design and operational, organizational, and support system features.

Example

Situation. Three materiel contractors have responded to the Army's requirement for a new attack helicopter. For the HUD system, only one of the contractors has included the capability to accept FLIR input. All three proposed HUD subsystems accept conventional radar and electro-optical input.

Result. The analyst concludes that the IDHSS is preferred on the basis of the similarity criterion. Since the IDHSS accepts all three inputs, it is most similar to the ideal Proposed System which meets all of the functional and performance requirements. No other alternatives meet all of the requirements.

Action Step 3: Apply Data Criterion

Requirements

As a practical concern, sufficient data describing BCS equipment must be available for (1) performance of comparability analyses and (2) generation of Proposed System MPT information. The quantity and quality of data available for the BCS candidate equipment will be considered in this action step.

Objective

The objective of this action step is to insure that BCS candidate equipment has sufficient and sufficiently mature data

Procedures

The analyst uses the criterion stated below to evaluate the BCS candidate equipment identified previously.

Criterion. The preferred BCS equipment has sufficient and sufficiently mature data available. Sufficiency should be judged in terms of the extent to which the following data elements are available for each BCS candidate equipment:

- Equipment usage rates
- Mean duration of usage
- Frequency of failure
- Frequency of maintenance actions, both corrective and preventive
- Effect of failure
- Task descriptions for both operation and maintenance tasks
- Task times, elapsed and total
- Task time allowance (e.g., productivity, make-ready/put away) .
- Task frequencies, inherent and induced
- MOS/skill level performing tasks
- Number of personnel performing tasks
- Maintenance level for maintenance tasks

C/Substep 1.6

Maturity should be judged in terms of the extent to which the values for the above data elements have been (1) obtained from observations of system performance under operational conditions in the field and (2) obtained from the greatest number of observations.

If the analyst discovers a complete lack of data for a particular BCS candidate equipment, or if data is available but may not be obtained in a timely manner, then that item may be excluded from further consideration. Experience has shown that availability of data is the most critical criterion in establishing the BCS.

Example

Situation. The situation from the previous examples is continued here. Table 1.6-5 displays data availability for the BCS candidate components.

Table 1.6-5. Applying Data Availability Criteria to BCS Candidates

<u>Head-up Display Nomenclature</u>	<u>Data System Available</u>	<u>Data Meet Sufficiency Criterion</u>	<u>Number of Observations (Rank)</u>
AN/AVQ-20 for F-15	Air Force 66-1	90%	3
Kaiser- built Display for F-16	Air Force 66-1	90%	1
AN/AVQ-28 for F/A-18	Navy 3M	100%	2
IHDSS	Army Sample Data Collection	30%	4

Action Step 4: Select Preferred BCS Equipment

Requirements This action step summarizes the results of the criteria applied in the previous action steps.

Objective The objective of this action step is to establish the BCS Equipment Structure. This structure is the result of replacing items from the generic equipment structure with the BCS equipment which best satisfies the criteria previously applied.

Procedures The analyst selects from the list of BCS candidates the item which, in his judgment, best meets the functional, similarity, and data criteria. This item is entered in the appropriate position in the equipment structure. Data and other information on the candidates not selected are retained for potential use in tradeoff analyses.

The analyst repeats the entire selection process for each EIC in the generic equipment structure. When each EIC has been assigned an item which has satisfied the BCS selection criteria, the BCS Equipment Structure has been completed.

Example Based on the results of all previous examples, the analyst ranks the BCS candidates as follows:

1. AN/AVQ-28
2. AN/AVQ-20
3. Kaiser-built for F-16
4. IHDSS

C/Substep 1.6

The lack of data excludes the IHDSS from consideration as a BCS candidate, although it may be used in a tradeoff. The Kaiser-built model and the AN/AVQ-20 satisfy the data criterion equally, but the AN/AVQ-28 is preferred because it satisfies more functional/performance requirements.

Substep 1.7/Overview

Establish Proposed System

Overview

The Proposed System is an analytical construct developed to represent the best estimate of the design of the new system. As with the BCS, the Proposed System is developed by identifying specific hardware components which perform system-level functions and tasks and is expected to fulfill all system functional requirements.

Unlike the BCS, however, the Proposed System is expected to meet all goals with respect to how well system functions are performed. To satisfy this expectation, the Proposed System may incorporate technological advances likely to exist before the system's projected Initial Operational Capability date.

These technological advances may not be mature in the sense of capabilities demonstrated by actual performance in the field. Accordingly, data associated with the components of the Proposed System need not be mature. They may come from less empirical sources such as laboratory tests or engineering estimates.

This technological immaturity is also unlike the BCS, where, to qualify for inclusion, a component had to have mature, empirical field data available. The maturity of data used for the BCS and the Proposed Systems forms a crucial distinction between the two systems.

When analysis begins, one or more Proposed Systems may already be available. Typically, the number of Proposed Systems reflects the number of major technological approaches being considered (e.g., a gun design versus a missile design) or the number of unique design solutions offered by competing materiel contractors in response to a preliminary statement of mission need or system requirement by the Army.

Substep 1.7/Overview

Each Proposed System may either be an actual design obtained directly from a contractor or a conceptual design developed by the HARDMAN analyst. In the latter case, the conceptual design will include technological advances and/or new operating and support concepts which are likely to be incorporated in the eventual Proposed System design to be fielded.

Establishing a conceptual Proposed System is required when contractor designs are not available. Lack of design availability is typical during the early phases of the acquisition process. As the acquisition progresses, the conceptual design is replaced by the actual designs being proposed by contractors. When contractor-provided designs are available but incomplete, a combination of the two approaches is used.

Objective

The purpose of this substep is to establish and describe the Proposed System alternatives for use in HARDMAN comparability analyses.

Input

Input from earlier HARDMAN substeps includes the operational and support concepts for the Proposed System from Substeps 1.1 and 1.2, the system functional requirements developed in Substep 1.3, and the BCS equipment list generated by Substep 1.6. For cases in which actual proposed designs have been completed, this information is an important input to Substep 1.7.

Finally, to establish conceptual designs for all or part of the new system, information on Proposed System design concepts and applicable new technologies must be collected for this substep.

Products

This substep produces a Proposed System equipment list for use in equipment comparability analyses conducted throughout the remaining HARDMAN processes. The equipment must be specified only to the level of detail required to satisfy the study objectives.

Logic

Figure 1.7-1 represents the logic flow for establishing the Proposed System.

As shown in the figure, four action steps are required in this substep. Action Step 1 considers proposed designs which actually exist. Proposed System actual designs may or may not be complete.

Action Steps 2, 3, and 4 generate Proposed System components which may be used to complete actual proposed designs which are incomplete or to develop a Proposed System alternative on a component-by-component basis. When all positions, or EICs, in the generic equipment structure have been assigned an item of Proposed System equipment, the Proposed system-level equipment structure has been established.

Action Steps

Action Step 1: Obtain Proposed System Designs [Actual]

Requirements

Establishing the Proposed System(s) may be an easy exercise if detailed, complete contractor designs of the new system exist. Contractor designs may simply serve as alternative Proposed System designs.

However, in early applications of the HARDMAN methodology, actual designs are commonly unavailable or incomplete. The analyst must

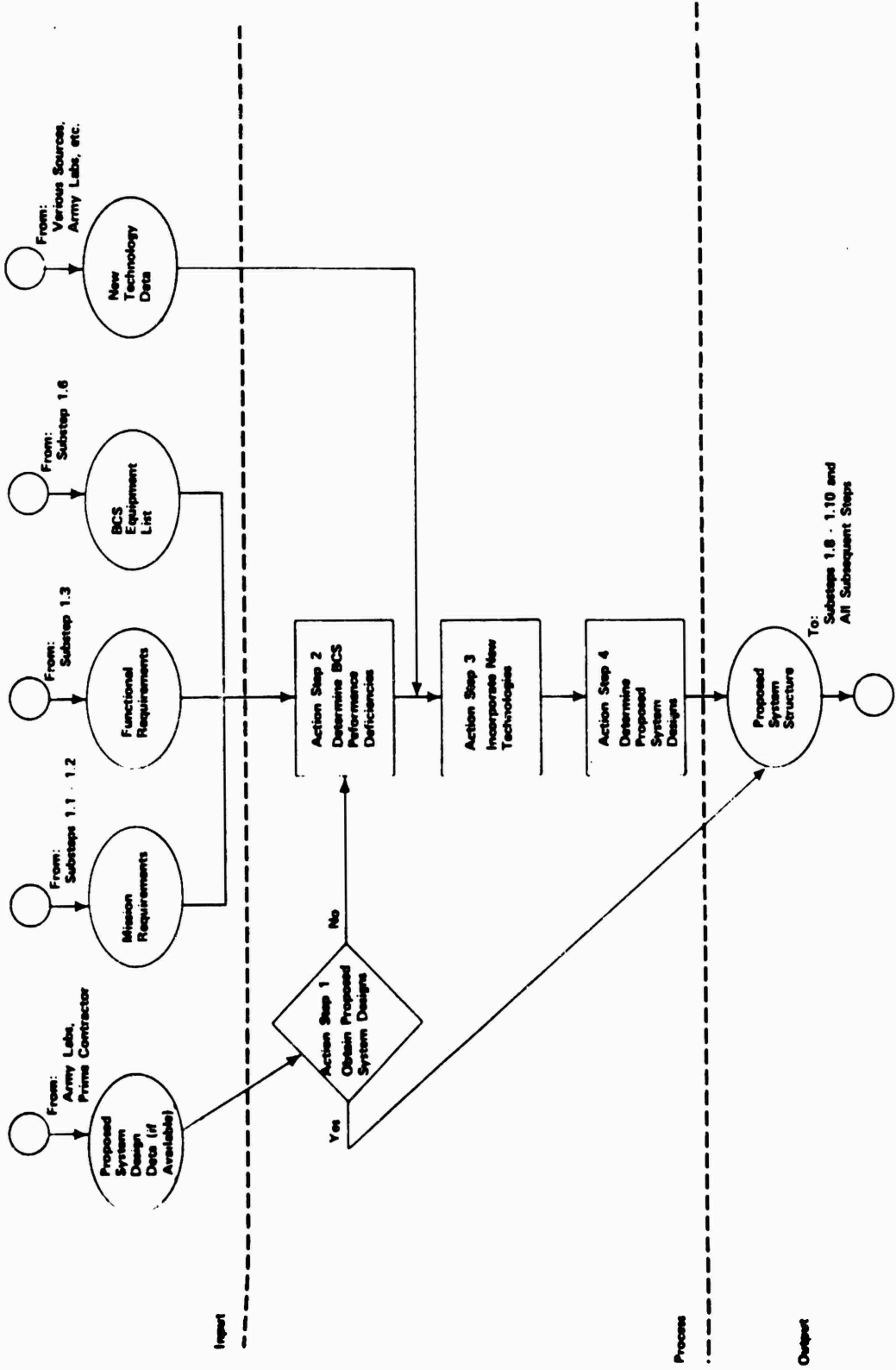

Figure 1.7-1. Establish Proposed System logic.

either identify existing Proposed System design information, if any, or develop system components in Action Steps 2, 3, and 4.

Objective

The objective of this action step is to identify available actual designs of Proposed System components for inclusion in the HARDMAN Proposed System configuration.

Procedures

Action Step 1 will be performed only if actual new system designs are available. For HARDMAN applications early in an acquisition, actual design information is not likely to exist.

1. The analyst must determine the existence of and collect design information for available proposed subsystems and equipment. Sources of such design information may include contractor proposals, drawings and other design documents, mock-ups, equipment prototypes, etc. Design information must be documented to the level of detail required to support comparability analyses with the BCS.
 2. The analyst insures that the actual designs of the Proposed System components adhere to Proposed System operational and support concepts, and notes where deviations occur.
 3. The analyst determines what new system functional and performance requirements are satisfied by the actual Proposed System component designs.
 4. The analyst determines the specific BCS equipment and the generic equipment to which each actual Proposed System component design corresponds.
-

C/Substep 1.7

Example

Situation. The new system is to be a very high frequency, frequency modulated (VHF-FM) radio. Generic and BCS equipment has been identified as follows:

<u>Generic Equipment</u>	<u>BCS Equipment</u>
Receiver/Transmitter	AN/ARC-114
Antenna coupler	CU2041/AR
Whip antenna	AT-892/PRC-25
Vehicular antenna	AT-1095/VRC
RF amplifier	AM6176/VRC
Battery	BA-4386/U

The XYZ Corporation, a materiel contractor, has submitted a proposal to satisfy the requirement for the new radio. All of the equipment is of new design. The contractor's proposed configuration is as follows:

<u>Name</u>	<u>Description</u>
Basic unit	Receiver/transmitter, RF amplifier, and battery in one self-controlled unit
Vehicular antenna	Antenna and integral coupler
Portable antenna	Whip antenna and integral coupler

Results. The analyst examines the descriptive data and specifications in the XYZ proposal. Two conclusions are reached: (1) the contractor equipment appears to meet the new system functional requirements and (2) the data are sufficient to support further analyses. The analyst accepts the XYZ equipment as a Proposed System alternative.

Action Step 2: Determine BCS Performance Deficiencies

Requirements

To complete the Proposed System design, the engineering analyst must project a conceptual design of system components for which an actual design does not yet exist. The basis from which to make this projection is the BCS equipment configuration and the deficiencies in BCS functional capabilities as compared to new system performance requirements.

Objective

The objective of this action step is to identify the functional deficiencies of BCS components for which conceptual designs must be projected.

Procedures

Action Step 2 will be performed unless the entire Proposed System was developed in Action Step 1.

1. The analyst selects an EIC and identifies new system functional and performance requirements which may not be satisfied by the Proposed System components identified thus far.
2. For the corresponding EIC in the BCS equipment structure, the analyst identifies BCS equipment.
3. The analyst matches the new system functional and performance requirements from Procedure 1 with the BCS equipment from Procedure 2. The analyst identifies the BCS performance shortfalls. These shortfalls should be readily available from application of the BCS selection criteria in Substep 1.6 (Establish BCS).

C/Substep 1.7

Example

Situation. The situation of the first example is continued here. The XYZ Corporation has withdrawn its proposal. The analyst must develop a Proposed System alternative. The first step involves investigating the performance deficiencies of the BCS. The analyst begins with the receiver/transmitter.

Results. Through research and engineering judgment, the analyst obtains the following results:

<u>Generic Equipment</u>	<u>BCS Equipment</u>	<u>BCS Performance Deficiencies</u>
UHF Receiver/transmitter	AN/ARC-614	—Slow rate of frequency selection —Manual control —Few preset channels —No digital frequency readout

Action Step 3: Incorporate New Technologies

Requirements

The Proposed System design must overcome the BCS performance deficiencies identified in Action Step 2. Action Step 3 generates a Proposed System conceptual design by identifying technological improvements to the BCS which permit the new system to achieve its functional and performance requirements.

Objective

The objective of this step is to identify and document technological improvements to the BCS design which overcome the BCS performance deficiencies identified in the previous action step.

Procedures

Action Step 3 is performed if Action Step 2 identifies BCS performance deficiencies.

1. The analyst identifies and analyzes new technologies which may provide design solutions to the BCS performance deficiencies identified in Action Step 2. To be considered, such new technologies must be available at the time the new system is to be fielded. The two major sources of information on new technologies are (1) equipment-related literature and documents and (2) interviews with subject-matter experts.

2. New technologies which represent the most likely design improvements to the BCS design are selected for the Proposed System design. The technological improvements are incorporated into BCS equipment designs, yielding conceptual designs for corresponding Proposed System equipment. Alternatively, the technological improvements may be embodied in equipment which replaces, rather than updates or modifies, BCS equipment. Technological improvements are documented in the Design Difference Index (see Substep 1.8, Determine Design Differences).

3. Thus, the Proposed System conceptual equipment is a function of the BCS equipment and new technology:

$$\begin{array}{rcl} \text{BCS} & & \text{New} \\ \text{Equipment} & + & \text{Technologies} \\ & & = \\ & & \text{Proposed} \\ & & \text{System} \\ & & \text{Equipment} \end{array}$$

C/Substep 1.7

Example

Situation. The situation of the previous examples is continued.

Results. The analyst researches the new technologies likely to be available to overcome the BCS performance deficiencies. The following results are obtained:

<u>BCS Performance Deficiency</u>	<u>Potential Technology Improvement</u>
—Slow rate of frequency selection	—Increase response with large or very large scale integrated circuits (LSI/VLSI)
—Manual control	—Automatic control provided by LSI/VLSI with microprocessor
—Few preset channels	—More preset channels with mass memory
—No digital frequency readout	—Existing technology add readout

Action Step 4: Determine Proposed System Designs

Requirements

The analyst must combine the conceptual Proposed System components with those actually available to complete the development of the Proposed System.

Objective

The objective of this action step is to complete development of the Proposed System.

Procedures

Performance of Action Step 4 follows Action Steps 2 and 3 and, by complementing the results of Action Step 1, completes the HARDMAN Proposed System.

1. The analyst repeats Action Steps 2 and 3 for each EIC.
2. The actual and conceptual Proposed System equipment which results from Action Steps 1 thru 3 is combined to produce an equipment structure for a Proposed System alternative:

Proposed System Actual Designs	+	Proposed System Conceptual Designs	=	HARDMAN Proposed System
---	---	---	---	-------------------------------

3. The analyst applies Proposed System operational and support concepts to the Proposed System equipment structure to insure a reasonable level of system integration.
4. The analyst repeats Action Steps 1 through 4 for each Proposed System alternative.

Example

If the XYZ Corporation had not withdrawn, its R/T unit would have been accepted as the Proposed System alternative. The analyst would then have proceeded to an examination of the design differences in Substep 1.8 (Determine Design Differences).

The Proposed System R/T unit developed by the analyst is the AN/ARC-144, which incorporates the technological improvements identified in Action Step 3. These improvements also form the basis for the design differences.

This page intentionally left blank.

Substep 1.8/Overview

Determine Design Differences

Objectives

Previous substeps have established the equipment structures for the BCS and all Proposed System alternatives. The first objective of this substep is to determine differences between the BCS and each Proposed System alternative. Design differences are sought in terms of the specific equipment or technology that is incorporated in the Proposed System in order to meet the functional requirements of the new system.

The second objective is to estimate what effect, or impact, these differences are likely to have on the data elements and parameters which will be used to compute the system's manpower, personnel, and training (MPT) requirements in subsequent substeps. Action Step 2 addresses this issue.

Input

Input from earlier HARDMAN substeps includes the BCS equipment list as well as descriptions and specifications of each BCS component from Substep 1.6. Substep 1.7 contributes an equipment list for each Proposed System alternative, descriptions and specifications for actual Proposed System components, and descriptive information on the technological improvements incorporated into conceptual Proposed System components.

Products

The output of this substep is a quantification of the design differences between the BCS and each Proposed System alternative. Design differences are arrayed in a Design Difference Index (DDI), which supports extrapolation of BCS data. A separate DDI is constructed for each BCS/Proposed System comparison, i.e., one for each Proposed System alternative. Table 1.8-1 provides a sample Design Difference Index.

Table 1.8-1. Sample Design Difference Index (DDI)

Change Number	EIC	BCS Equipment	Proposed Equipment	Difference	Source	Impact	PV	Remarks
001	80ZZ	CJ2637/ARC-84 Signal Data Converter (P-3 Converter)	Digital Data Device	Replacement. Proposed Has More Complex Circuitry To Support A Greater Range of Bands Per Second. Also has Measuring Unit and Memory	BCS: Navy 3M P-3 Proposed: DEP 11-5820-ABC-10	Increased Corrective Maintenance Calibration	.2	Apply to Task Frequency

BCS data extrapolations are performed in Substep 1.9 (Determine R&M Requirements) and subsequent substeps. Results are used to fill gaps in Proposed System reliability, maintainability (R&M), and other performance data.

Logic

A comparison of BCS and Proposed System equipment results in identifying differences both in configuration and in the type of technology employed in each. The design differences form the rationale for perturbation of reliability, maintainability, and other data from the BCS to estimate values for the same data elements in the Proposed System. Quantification of the design difference impacts is the factor which affects determination of the BCS and Proposed System alternatives' MPT resource requirements in later substeps.

Figure 1.8-1 depicts the logic flow for determining design differences. As the figure shows, Substep 1.8 entails two action steps. This substep is repeated for each BCS/Proposed System comparison.

Action Steps

Action Step 1: Identify and Categorize Design Differences

Requirements

The analyst identifies design differences between the BCS and the Proposed System and categorizes them as differences in configuration and/or in technology employed.

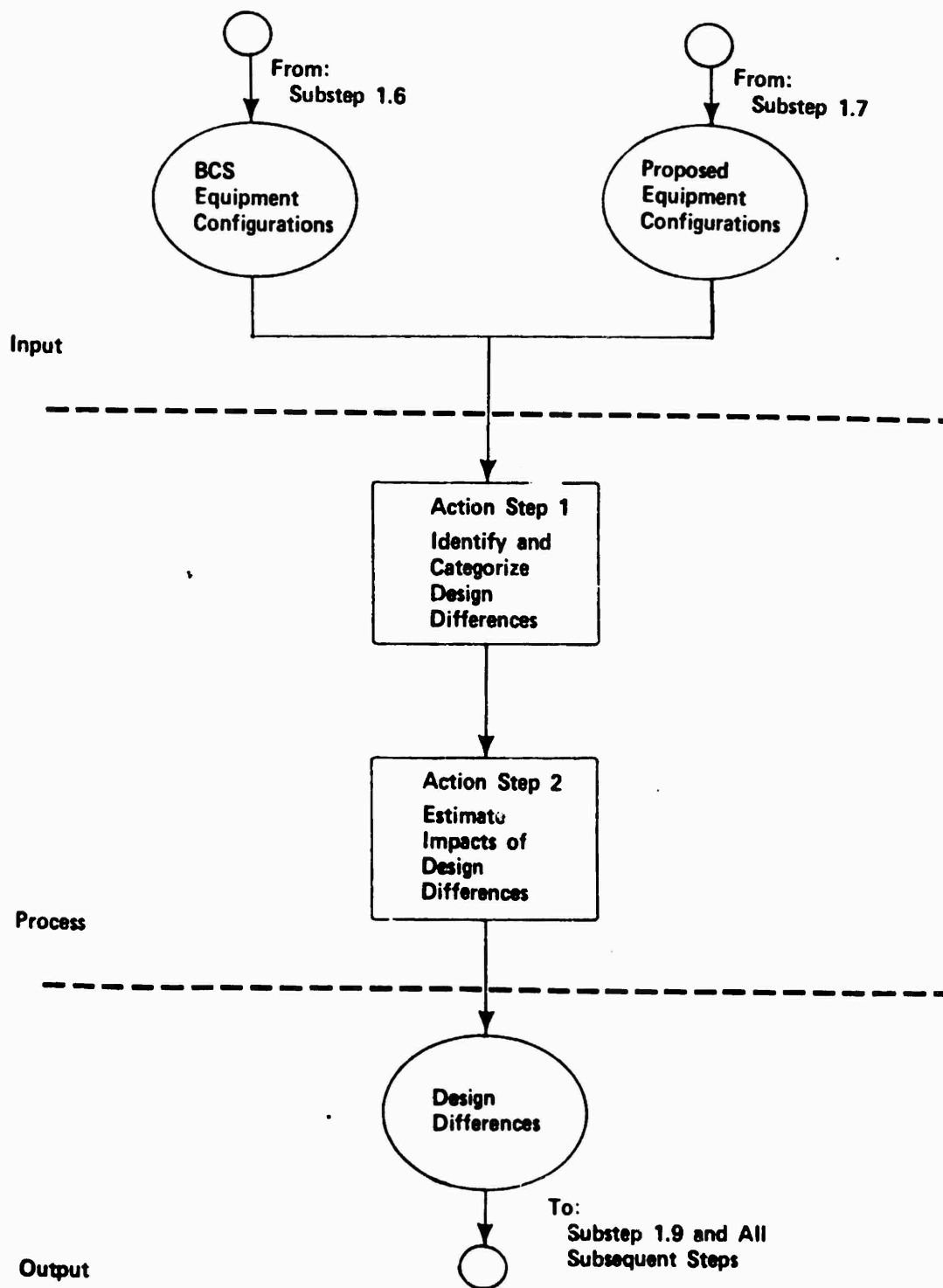

Figure 1.8-1. Design Difference Determination logic.

Objective The objective of this action step is to determine the nature of the design differences between the BCS and Proposed System alternative.

Procedures 1. The analyst selects BCS and Proposed System equipment from one EIC, then compares the Proposed System equipment to that of the BCS. Differences in configuration between the two are classified as follows:

When compared to the BCS, the Proposed System equipment is:

Classified as	If
Addition	Subsystems/components/ assemblies/parts have been added to those of the BCS
Deletion	Subsystems/components/ assemblies/parts have been deleted from the BCS
Replacement	Proposed System equipment has wholly replaced BCS equipment
Modifica- tion/Im- provement No change	Proposed System equipment is a modified/improved version of BCS equipment BCS and Proposed System equipment is the same

Note that combinations of categories can exist. In other words, deletion of some components may be possible if the ones that remain are modified and/or improved.

2. For cases where the comparison results in a replacement or a modification/improvement, the analyst determines the nature of the technology that will be (1) in the Proposed System equipment which is replacing the BCS

C/Substep 1.8

equipment or (2) incorporated into the BCS by modification/improvement. The analyst must exercise professional judgment in determining the nature of those differences. Table 1.8-2 lists some of the factors to be considered.

Table 1.8-2. Design Difference Considerations

<u>Factor</u>	<u>Elements</u>
Physical Features	Size, weight, volume, number of units
Location	Concentration vs. dispersion of the components/assemblies on the system
Electrical Design	Digital vs. analog, level of internal functional integration, degree of modularity, miniaturization, accessibility
Mechanical Design	Accessibility, complexity of major moving assemblies, tolerances
Special Tools/Test Equipment	Degree to which they are required
Build-In/Aug-In Test Equipment (BITE/PITE)	Degree to which BITE/PITE is present, degree to which it covers all components or only selected ones
Software	Compatibility between/among subsystems, degree to which software aids and/or replaces human performance
System Integration	Sharing controls and displays for several functions, number of interconnections, extent to which a bus exists, type of bus

3. In the appropriate DDI columns, the analyst records the EIC, the nomenclature of the BCS and Proposed System equipment, the design differences, and the source of the information used to determine the design differences. Assigning change numbers may also facilitate retrieving the information later in the analysis. Close attention should be paid to describing the nature of the technological differences; shorthand or highly subjective terms are acceptable if adequately explained.

Example Table 1.8-3 provides an example of a DDI with design difference information recorded.

Action Step 2: Estimate Impacts of Design Differences

Requirements The analyst determines whether estimates of reliability, maintainability, and task performance data are available for the Proposed System equipment. If data are not available, the analyst must estimate the quantitative effect, or impact, the design differences identified in Action Step 1 will have on BCS R&M and task performance data.

Objective The objective of this action step is to estimate the quantitative effect of the design differences identified in the previous action step.

Procedures

1. The analyst determines the availability of R&M and task performance data for Proposed System equipment. Ideally, data elements are available at the greatest level of detail -- task time and task frequency for operator and maintainer tasks. However, the procedures may be applied to more summary parameters such as the maintenance ratio (MR).

Table 1.8-3. Design Difference Example.

Change Number	EIC	BCS Equipment	Proposed Equipment	Difference	Source	Impact	PV	Remarks
001	1601	Collsprings	Hendrikson RT 340 Leafsprings; Steel Saddle Equalizing Beam	Replacement. Leafspring More Durable Under Heavy Loading and Rough Terrain	XYZ Proposal			

Sources of such data include materiel contractor proposals, drawings, and other design documents; equipment prototypes and mock-ups; and the Logistics Support Analysis Record (LSAR), especially for systems in the later phases of the acquisition process. Preliminary results from Sample Data Collection, Development, and/or Operational Tests may also be considered, especially if the results are sufficient to provide estimates of task time and frequency but do not satisfy selection criteria for the BCS.

If actual Proposed Systems exist (see Substep 1.7, Action Step 1), or if the design difference for the EIC under analysis is an addition or replacement, the analyst should make every effort to obtain values for the R&M and task performance parameters.

2. If data are not available, the analyst determines whether design differences identified in Action Step 1 will affect any of the parameters of concern — operator and maintainer task time and frequency — or more summary parameters.

3. For the parameters affected, the analyst must estimate a perturbation value (PV). A PV is used to adjust the values of the BCS parameters to estimate parameter values for the Proposed System. A PV must have both magnitude and direction. That is, it must increase or decrease the BCS values to the limit indicated by the specific nature of the design difference.

The analyst must judge both the magnitude and the direction of the PV based on the design differences. Neither may be readily apparent to the analyst. Experience has shown that both factors are affected by the particular area of technology under consideration.

C/Substep 1.8

For example, in electronics a decrease of 30 percent in maintenance task times may be reasonable, given the advances made in miniaturization and modularity. An improvement of that magnitude may be harder to account for in automotive components.

To the extent permitted by the study's scope, the analyst should consult with experts in the technology area. Multiple opinions on the magnitude and direction of the PVs are more useful (and easier to defend) than single estimates.

As a general rule, PVs of 10 percent or less represent low risk improvements; 11 to 30 percent, medium risk; and over 30 percent, high risk. The more risk involved, the more attention the analyst should devote to securing a consensus from subject-matter experts not involved in the HARDMAN application.

4. The analyst now quantifies the impact of the design differences:

- Where Proposed System data is available, the impact is the result of subtracting the BCS values from the Proposed System values:

$$\begin{array}{rcl} \text{Proposed} & & \text{BCS} \\ \text{System} & - & \text{Values} \\ \text{Values} & & = \\ & & \text{Design} \\ & & \text{Difference} \\ & & \text{Impact} \end{array}$$

- If Proposed System data is not available, the impact is the product of the BCS values and the PV, provided the PV is expressed as a decimal which equals the percent change and has a positive or negative value to indicate the direction of change:

$$\begin{array}{rcl} \text{BCS} & & \text{Design} \\ \text{Values} & \times \text{ PV} & = \\ & & \text{Difference} \\ & & \text{Impact} \end{array}$$

Proposed System values are always the sum of the BCS values and the quantitative impact of the design differences.

5. If a PV is obtained, the analyst records the PV in the appropriate column on the DDI. If data are available for the Proposed System, then both the BCS and the Proposed System values should be reflected in the Remarks column. The PV column is left blank.

6. Even if Proposed System data are available, the analyst should estimate PVs for the EIC under analysis as well as obtain the design difference impact by subtraction. Both methods may be applied if warranted by the scope of the analysis. When both methods are employed, PVs provide a useful check on the Proposed System values provided by materiel contractors.

Example

The situation of the previous example is continued. Table 1.8-4 shows a DDI with the impact of design differences recorded. Note that the PV is positive because it is applied to the MTBF/MTBMA, which will increase if improved. If applied to the failure rate, the PV would have a negative value; an improved rate would be lower. Magnitude would be adjusted accordingly.

Table 1.8-4. Design Difference Impact Example

Change Number	EIC	BCS Equipment	Proposed Equipment	Difference	Source	Impact	PV	Remarks
001	1801	Coilsprings	Hendrikson RT 340 Leafsprings: Steel Saddle Equalizing Beam	Replacement. Leafspring More Durable Under Heavy Loading and Rough Terrain	XYZ Proposal	Higher Reliability	.2	Apply to MTBF/ MTBMA. Leafsprings are Existing Technology But Actual Data is Unavailable.

Substep Group 1D

Reliability and Maintainability Analysis

Overview

Results of this substep group include the quantitative reliability and maintainability (R&M) parameters associated with the Predecessor, BCS, and Proposed System alternatives. R&M parameter values for all alternatives are provided to the maintainer workload calculations.

Reliability is defined by Army Regulation 702-3 (Reliability and Maintainability), as "the probability that an item will perform its intended function for a specified interval under stated conditions." When a reliability parameter is being determined, the practical applications of this definition are limited.

AMC/TRADOC Pam 70-11 (RAM Rationale Report Handbook) recognizes at least two other, more inclusive definitions. HARDMAN reliability analysis uses the broadest definition, where the reliability parameter is considered as the demand for maintenance resources. This concept is also termed "operating and support cost reliability."

AR 702-3 defines maintainability as "a characteristic of design and installation which provides inherently for the item to be retained in or restored to a specified condition within a given time, when the maintenance is performed in accordance with prescribed procedures and practices." A HARDMAN application includes efforts to estimate all of the maintenance requirements associated with a given design, not only those inherent, or fundamental, to the design itself.

Aspects of the system's operational and maintenance environment also induce the requirement for maintenance to be performed. The HARDMAN methodology endeavors to capture the parameter values associated with this situation. Drawing a distinction between inherent and induced maintenance allows the

Step 1D/Overview

analyst to estimate the probable success of design solutions to lower manpower, personnel, and training (MPT) requirements based on R&M parameters. This capability is particularly valuable in Substep 6.1 (Identify Tradeoff Alternatives).

Logic

The Predecessor, BCS, and Proposed System alternatives were defined in Substep Group 1C (Equipment Comparability Analysis). Also, design differences and their impacts were identified for BCS and Proposed System alternatives.

In Substep 1.9, reliability and maintainability parameters are identified and assigned to each system alternative. These parameters are used to derive maintainer workload in Substep 2.5 (Determine Maintainer Workload).

Historical and projected R&M data are collected, analyzed, and adjusted to insure consistency across alternatives. If necessary, the perturbation values (PVs) developed in Substep 1.8 (Determine Design Differences) are applied to the BCS R&M parameter values to estimate values for the Proposed System alternatives. R&M parameter values for all alternatives are provided to the maintainer workload calculations in Substep 2.5 (Determine Maintainer Workload).

Figure 1D-1 depicts the logic flow determining the R&M parameter requirements of the system alternatives. This figure shows the major input, processes, and output of the substep group. As shown in the figure, this substep group consists of Substep 1.9 (Determine Reliability and Maintainability Requirements), which contains four action steps.

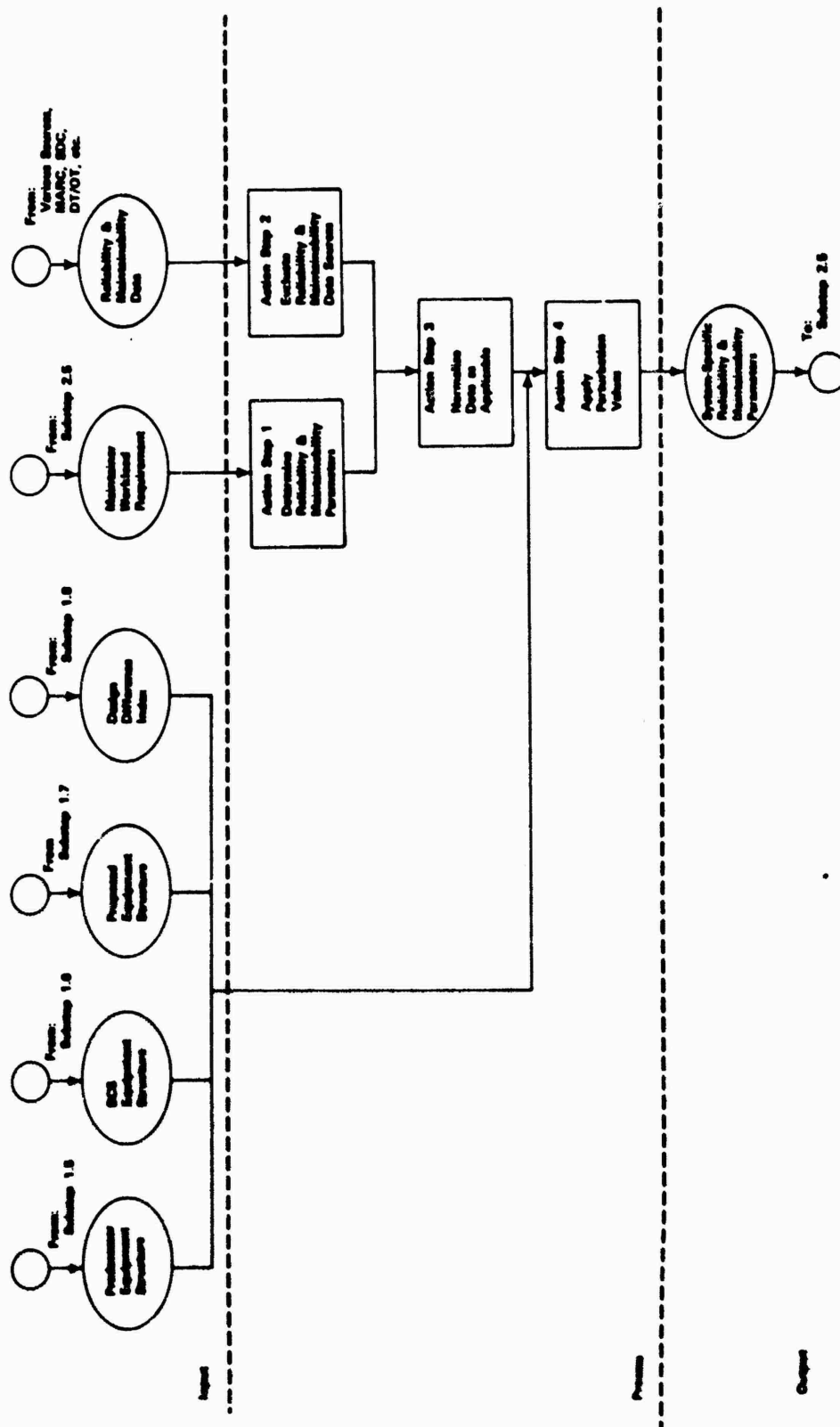

Figure 1D-1. Reliability and Maintainability logic.

This page intentionally left blank.

Substep 1.9/Overview

Determine Reliability and Maintainability Requirements

- Objective** The objective of this substep is to develop values for reliability and maintainability (R&M) parameters for the Predecessor, BCS, and Proposed System alternatives.
- Input** Input from other HARDMAN substeps includes the Predecessor, BCS, and Proposed System equipment structures and their descriptive information from Substeps 1.5, 1.6, and 1.7, respectively. The Design Difference Index (DDI) for each BCS/Proposed System comparison is obtained from Substep 1.8.
- Other input includes historical and projected R&M data on each alternative. This information may be obtained from maintenance data collection programs of the military services; development, operational, and/or independent test results; engineering estimates from government or private subject-matter experts; and relevant reports and documentation.
- Products** The products of this substep are quantitative R&M parameters for each system alternative. These values are used to determine maintainer workload in Substep 2.5 (Determine Maintainer Workload).
- Logic** Figure 1D-1 depicts the logic flow for determining R&M parameter requirements. As shown in the figure, this substep entails four action steps. The first two action steps are performed simultaneously, then followed by Action Step 3. Action Step 4 is applied only when R&M values for the Proposed System must be estimated with the perturbation values (PVs) developed in Substep 1.8.

D/Substep 1.9

Action Steps

Action Step 1: Determine Reliability and Maintainability [R&M] Parameters

Requirements

Selection of suitable R&M parameters is directly related to the determination of maintainer workload and manpower in Step 2 (Manpower Requirements Analysis). Several different parameters may express the same information, or several may be combined in different ways to obtain the same result. Different sources of R&M data use different parameters. Note that different parameters may be appropriate for dissimilar systems.

When evaluating the usefulness of the data sources, the analyst must know the parameters of interest to subsequent HARDMAN steps. If the parameters are not to be obtained directly from the data source, the analyst must determine whether the parameters can be derived from available data.

Objective

The objective of this action step is to determine what R&M parameters are most suitable for application in Substep 2.5 (Determine Maintainer Workload).

Procedures

1. The analyst consults with the Workload analyst and determines the parameters or data elements needed to support determination of maintainer workload. These data elements are contained in Substep 2.5 (Determine Maintainer Workload) but repeated in Table 1.9-1 for convenience.

Table 1.9-1. Maintenance Workload Data Elements

Workload Equation Data Elements	
Use	Quantitative requirements for operational system activity/use under scenario conditions; expressed in all relevant metrics (miles driven, rounds fired, hours operated, etc.)

Table 1.9-1 Maintenance Workload Data Elements [con't.]

Workload Equation Data Elements	
Period	Duration of the scenario requirement (day, week, month, year)
Actions	Number of maintenance actions for each action type (remove, replace, repair, troubleshoot)
Labor	Maintenance man-hours (MMH) for one action of each type
Other Descriptive Information	
For Actions	
Cause	Primary reason for the action (hardware, software, operator error, maintenance error, accident)
Effect	The result or outcome of the action on the system's mission
For Labor	
MOSC, Paygrade, and Duty Position	For the maintainer who is assigned responsibility and/or is performing the action
Maintenance Level	Where the action occurs
Mean Time to Repair (MTTR)	Average elapsed time required to perform the action
Number of Maintainers	If the action requires more than one maintainer in order to be performed successfully

Such detailed descriptions of the data elements may not exist. Instead, they may be expressed simply as a "maintenance ratio" (MR). A maintenance ratio is defined as the ratio of maintenance man-hours to a unit of system usage. Examples include 14 maintenance man-hours per flying hour, 2.5 maintenance man-hours per mile, etc.

Typically, an MR is expressed just for all maintenance workload at a particular maintenance level or echelon. However, in theory an MR is the product of the reliability and maintainability terms of the maintenance workload equation. Consequently, it can be computed for one or all maintenance tasks or actions associated with one EIC.

For the R&M analyst, the equation usually takes the following form:

Reliability x Maintainability = MR

$$\frac{1}{M[M]BMA} \times MTTR \times K = \frac{\text{Manhours}}{\text{One Metric}}$$

Where:

M[M]BMA = Mean [Metric] Between the Maintenance Action being analyzed, with the metric expressed in time (MTBMA), rounds (MRBMA), etc.

MTTR = Mean Time To Repair, or the average elapsed or clock time required to complete the action

K = Number of people required for the action, a factor needed in order to convert clock time to man-hours

M[M]BMA, MTTR, K, and MR thus become the R&M parameters of practical concern to the R&M analyst. MR by itself may be a more summary parameter than those used to derive it. The analyst should select the parameters at a

level of detail which meshes with the available data and the scope of the analysis.

2. Values for the R&M parameters may not be available on a task-by-task or an action-by-action basis. However, they may be available for more summary groupings, or "workload categories." Maintenance workload is categorized as either Preventive or Corrective Maintenance. These categories are defined as follows:

- **Preventive Maintenance (PM).** Maintenance actions are conducted at scheduled, periodic intervals on operational systems, equipment, or components. These actions contribute to uninterrupted operation within design characteristics. Some examples are: check fluids prior to operating, clean and lubricate daily, and rotate annually.
- **Corrective Maintenance (CM).** This category covers maintenance performed on an unscheduled basis due to malfunction, failure, deterioration, or battle damage. These maintenance actions are required to restore disabled systems, equipment, or components to an operational condition within predetermined tolerances and limitations. Corrective Maintenance includes such activities as: repair broken pipe, replace burned transformer, and patch ripped canvas cover.

3. Some sources of R&M data distinguish between "inherent" and "induced" maintenance. This distinction reflects the cause or reason for a particular maintenance action (see Cause in Table 1.9-1). Sometimes cause is referred to as "chargeability," i.e., the aspect of the system or its environment to which the action may be charged.

Inherent maintenance actions result from characteristics of the system itself — problems with its design, hardware, software, or manufacturing quality control. Induced maintenance actions result from the system's operating environment — shortcomings in the skills of its operators and maintainers, the availability of spare parts, the readability of system technical documentation, etc.

Table 1.9-2 cross-references the chargeable elements described in TRADOC/AMC Pamphlet 70-11 (Reliability, Availability, and Maintainability Rationale Report Handbook) with the more summary descriptions typically found in the data sources and employed in HARDMAN.

The analyst develops factors from the available data which permit the inherent vs. induced distinction to be made for the M[M]BMA metric. This distinction enables the analyst to estimate whether (1) design solutions to improve inherent R&M parameters will be successful or (2) effort would be better spent on reducing induced maintenance.

Action Step 2: Evaluate R&M Data Sources

Requirements

The R&M data sources incorporated depend on the various equipment and system configurations defined in Substep Group 1C (Equipment Comparability Analysis). These data sources are established by the type of system being analyzed, e.g., Predecessor, BCS, or Proposed. The analyst identifies candidate R&M data sources, evaluates them, and selects the most appropriate ones to support development of the required R&M parameter values.

Table 1.9-2. Causes of Maintenance Action

TRADOC/AMC Pamphlet 70-11		
HARDMAN Categories	Chargeable Elements	Includes
Inherent	Hardware	Hardware and personnel-related incidents attributable to hardware design
	Software	Embedded computer software, including BITE software, and personnel-related incidents attributable to software characteristics
Induced	Crew	(Self-explanatory)
	Maintenance Personnel	(Self-explanatory)
	Manuals	Personnel-related incidents attributable to misleading, incorrect, or missing information
	Support Equipment	Special and common tools, spares, repair parts, and associated support equipment and software
Other	Accident	Only accidents which cannot be charged to one of the other elements

D/Substep 1.9

Objective The objective of this action step is to select R&M data sources which best support development of the required R&M parameter values.

Procedures The analyst must evaluate each potential data source to determine if its data will support development of R&M parameter values for one or more system alternatives. Table 1.9-3 depicts typical data sources, the type of R&M data elements generally available from each source, and the general applicability of the data source to each HARDMAN system alternative.

After a thorough evaluation of available technical data, the analyst selects one or more sources. The following decision-making criteria are used to select data sources:

- **Predecessor** — R&M data for the Predecessor System are required if the manpower requirements of the Predecessor System are to be calculated rather than determined by allocation of existing requirements. The analyst should consult with the Manpower analyst to determine the more appropriate method.

If R&M data is required, field data should be available. If not, MARC provides estimated maintenance man-hour (MMH) requirements for each MOS associated with Predecessor Systems.

Note that field data and MARC estimates may be inconsistent. This situation should be less likely in the future, as field data from Sample Data Collection (SDC) are gradually replacing the engineering estimates which comprise most of the current MARC.

- **Baseline Comparison System (BCS)** — Selected data must satisfy the data criterion for inclusion in the BCS. In other words, data must be based on
-

Table 1.9-3. R&M Data Sources

Data Source	Type Reliability Data		Type Maintainability Data				
	Inherent	Induced	Corrective				
			Direct	Indirect	Preventive		
<ul style="list-style-type: none"> Actual Field Data SDC (controlled) Navy 3M Air Force 66-1 	x	x	x		x	x	x
<ul style="list-style-type: none"> Field Data SDC (semi-controlled) Operational Tests 	x	x	x	x	x	x	x
<ul style="list-style-type: none"> Development Tests 	x				x		
<ul style="list-style-type: none"> Field Data SDC (free-flow) TAMMS 	x	x	x	x	x	x	x
<ul style="list-style-type: none"> Logistic Support Analysis Record (LSAR) 	x				x		x
<ul style="list-style-type: none"> Manpower Requirements Criteria (MARC) 	x				x	x	
<ul style="list-style-type: none"> Engineering Estimates/Predictions 	x				x		x
<ul style="list-style-type: none"> Subject - Matter Experts 	x	x			x		x
<ul style="list-style-type: none"> Technical Documentation 	x				x		x

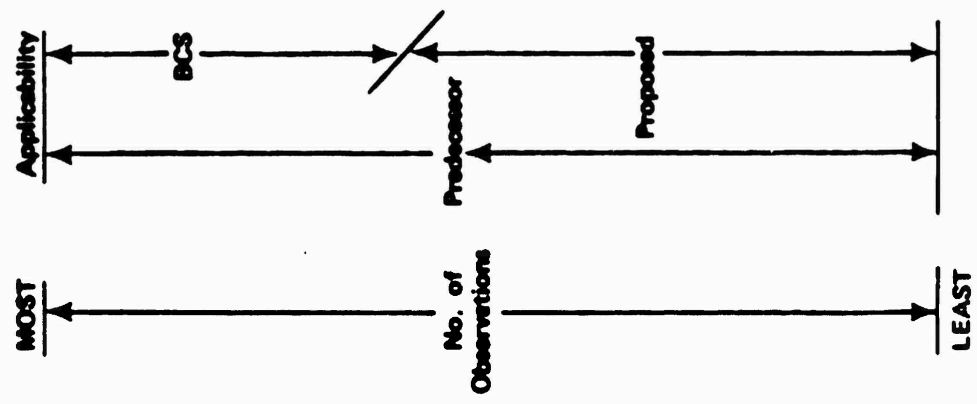

observations under field conditions. The best source of data is the one with the most observations (see Substep 1.6, Establish BCS).

- Proposed System — If actual data on the Proposed System are to be used, the data can come from other, non-field sources and can have a limited number of observations. System components which satisfy all criteria except BCS data but have some data available are good sources of Proposed System R&M data.

Examples

Example 1

Situation. An ongoing sample data collection (SDC) has fielded R&M data for the last three years on the Predecessor System. The data are available from the AMC system proponent.

Result. The analyst obtains the SDC information for at least two years and uses the data to establish Predecessor System R&M values. To the extent that Predecessor components are included in the BCS, the values obtained also satisfy the BCS criteria.

Example 2

Situation. Three Army SDCs, a DT/OT test report, and information from the Navy's maintenance data collection system (3M) are available to support the selection and use of candidate BCS subsystems and components.

Result. The analyst orders all relevant R&M documentation from the Army and the Navy. This information is evaluated for use as R&M parameters for the BCS. The most appropriate R&M data sources for the BCS are selected.

Example 3

Situation. Subject-matter experts (SMEs) are available in various Army R&D programs and technology labs for most of the new technology being incorporated into the Proposed System. Also, LSAR and a draft set of technical manuals have been developed for one Proposed System alternative.

Decision. The analyst consults with the SMEs to develop perturbation values (PVs) (see Substep 1.8, Determine Design Differences). LSAR input records and specific LSAR output summary reports are ordered. In addition, selected TMs, e.g., operator and maintenance types, are procured for possible use in determining preventive maintenance requirements for the Proposed System alternative.

Action Step 3: Normalize Data as Applicable

Requirements

The analyst must adjust the values obtained for the R&M parameters to insure consistent units of measure across data sources.

Objective

The objective of this action step is to insure that all R&M parameter values are consistent and include all required elements.

Procedures

This action step has no specific procedures. In short, the analyst must insure that the R&M parameter values obtained from all sources are in the correct dimensions and contain all required elements.

Examples

Example 1

From Sample Data Collection for one year, the engine group for one helicopter required 8.0 corrective maintenance man-hours (CM MMH) and 15.00 preventive maintenance man-hours (PM MMH) for a group total of 23.0 MMH at the organizational level of maintenance. During this period, the helicopter model operated an average of 103.2 flight hours (FH) per aircraft. The engine group maintenance ratio per aircraft is calculated as follows:

$$\begin{aligned} \text{MR} &= \frac{23.0 \text{ MMH}}{103.2 \text{ FH}} \\ \text{ORG} & \\ &= .22 \end{aligned}$$

The above calculation shows that this engine group requires .22 man-hours per operational hour at the organizational maintenance level. Similar values would be calculated for the other maintenance levels being evaluated.

Example 2

Another approach to determine a corrective maintenance ratio is to apply the metrics of the total number of maintenance actions (MAs) and the total maintenance man-hours per maintenance action (MMH/MA) with the average flight hours per aircraft in a given period of time. A different helicopter model has the following field data available for its engine group:

$$\begin{aligned} \text{Annual FHs} &= 103.2 \text{ FH} \\ \text{Annual MAs} &= 8.2 \text{ actions} \\ \text{MMH/MA} &= 2.4 \end{aligned}$$

The field data do not include preventive maintenance data. Preventive maintenance requirements are obtained from system technical manuals (TMs). Helicopter TMs indicate that 263.0 PM MMH are required to support the engine annually. The maintenance ratios are calculated as follows:

$$\begin{aligned} \text{MR}_{\text{ORG(CM)}} &= \frac{8.2 \text{ MAs} \times 2.4 \text{ MMH/MA}}{103.2 \text{ FH}} \\ &= .19 \text{ MMH/FH} \end{aligned}$$

$$\begin{aligned} \text{MR}_{\text{ORG(PM)}} &= \frac{263.0 \text{ MMH/Year}}{103.2 \text{ FH/Year}} \\ &= 2.55 \text{ MMH/FH} \end{aligned}$$

Therefore, the total MR at the organizational level is:

$$\begin{aligned} \text{MR}_{\text{ORG}} &= .19 + 2.55 \\ &= 2.74 \text{ MMH/FH} \end{aligned}$$

Example 3

A final approach is to determine a corrective maintenance ratio when only an inherent value is available from the primary data source. The situation described below illustrates this approach.

The Proposed System is a remotely piloted vehicle (RPV). The materiel contractor has furnished a Logistic Support Analysis Record (LSAR) which yields an inherent (design-related) corrective maintenance ratio of 0.34 MMH/FH at the organizational level. Review of a fielded corrective MR for this system is 0.85. This system's original inherent LSAR MR was projected to be 0.55. The induced corrective MR is computed as:

$$\begin{aligned}
 \text{Induced MR} &= \text{Fielded MR} - \text{LSAR MR} \\
 \text{Org (CM)} & \qquad \qquad \text{CM} \qquad \qquad \text{CM} \\
 &= 0.85 - 0.55 \\
 &= 0.30 \text{ MMH/FH}
 \end{aligned}$$

The percentage of the induced MR versus the total MR is calculated as follows:

$$\begin{aligned}
 \% \text{ MR} &= \frac{\text{Induced MR}}{\text{Fielded MR}} \\
 \text{Org} & \qquad \qquad \text{CM} \\
 \text{Ind CM} & \qquad \qquad \text{CM} \\
 &= \frac{0.30}{0.85} \\
 &= 0.35
 \end{aligned}$$

Therefore, using the calculated, historical MR percentages for a comparable system, the total RPV corrective MR equals:

$$\begin{aligned}
 \text{MR}_{\text{Org(CM)}} &= \\
 \text{Inherent MR}_{\text{CM}} &\times \frac{1}{1 - \% \text{ Induced MR}_{\text{CM}}} \\
 &= 0.34 \times \frac{1}{1 - 0.35} \\
 &= 0.34 \times \frac{1}{0.65} \\
 &= 0.34 \times 1.54 \\
 &= 0.52 \text{ MMH/FH}
 \end{aligned}$$

Action Step 4: Apply Perturbation Values

Requirements

An index of design differences was established in Substep 1.8 (Determine Design Differences). This substep identified new technologies or actual components that could be incorporated into the proposed designs.

Additionally, this step developed perturbation values (PVs) reflecting the introduction of the new technology. The PVs are used to estimate parameter values for the Proposed System when data on Proposed System components are not available. The analyst must apply the PVs to the BCS values in order to obtain the Proposed System values.

D/Substep 1.9

Objective

The purpose of this action step is to apply perturbation values (PVs) to BCS parameters in order to obtain values for the Proposed System.

Procedures

The analyst obtains the PV for an EIC from the Design Difference Index (DDI). The analyst reviews the design differences and confirms the potential impact of the PV on BCS R&M data. The PV is then applied to the appropriate R&M data element to produce the adjusted R&M data.

$$\begin{array}{l} \text{Proposed} \\ \text{System} \\ \text{Parameter} \\ \text{Value} \end{array} = \begin{array}{l} \text{BCS} \\ \text{Parameter} \\ \text{Value} \end{array} \times (1 + \text{PV})$$

This relationship is accurate, provided the PV is expressed as a decimal with a plus or minus sign as appropriate.

Example

Situation. An improved engine in the Proposed System is estimated to improve the MTTR of the BCS engine by ten percent. The BCS MTTR is 1.9 hours.

Results. The PV, $-.10$, is applied to the MTTR. ("Improving" the MTTR means reducing it.) The analyst obtains the following result:

$$\begin{array}{l} \text{Proposed} \\ \text{System} \\ \text{MTTR} \end{array} = 1.9 \times (1 + (-.10))$$
$$= 1.9 \times .90$$
$$= 1.71 \text{ hours.}$$

Substep Group 1E

Task Identification

Overview

Task identification is the next logical step beyond the functional identification and allocation process described in Substep 1.3 (Determine Functional Requirements). During this phase, the functions allocated to people, either alone or in combination with equipment and software, are further analyzed to identify tasks.

As used in this analytic process, the term "task" means human performance of some sort. Tasks may be characterized as equipment- or non-equipment-based.

Task identification results in specification of what tasks operators and maintainers of the BCS and Proposed System(s) will perform. A single task identification step, rather than a series of isolated actions, is preferable. The single step avoids the redundant, time-consuming aspects of task identification independently developed by trainers and manpower analysts.

The single step also avoids the problem of integrating and organizing data independently developed. Hence, without a common point of departure for subsequent task analysis, it becomes difficult to relate the impact of mission, functional requirements, and equipment on manpower, personnel, and training requirements.

The desired outputs of task identification are generic task taxonomies for each of the BCS and Proposed Systems. These task taxonomies are at a high level of abstraction.

Ideally, this level is the minimum necessary to support delineation of the interrelationships among system missions, system/subsystem functions, and specific

equipment selected for the BCS and Proposed Systems. This level is also the minimum needed to outline associated tasks and also to exclude certain tasks based on the selection of specific equipment, which distinguished the task taxonomies developed in this phase.

Logic

The logic flow for task identification is presented in Figure 1E-1. Substep 1.10 (Determine Generic Tasks) is the only substep required. In this substep, separate procedures are described for identifying both generic operator tasks and maintainer tasks. Two separate procedures are required because maintenance tasks are a function of equipment design, while operation tasks depend on both equipment design and operational doctrine.

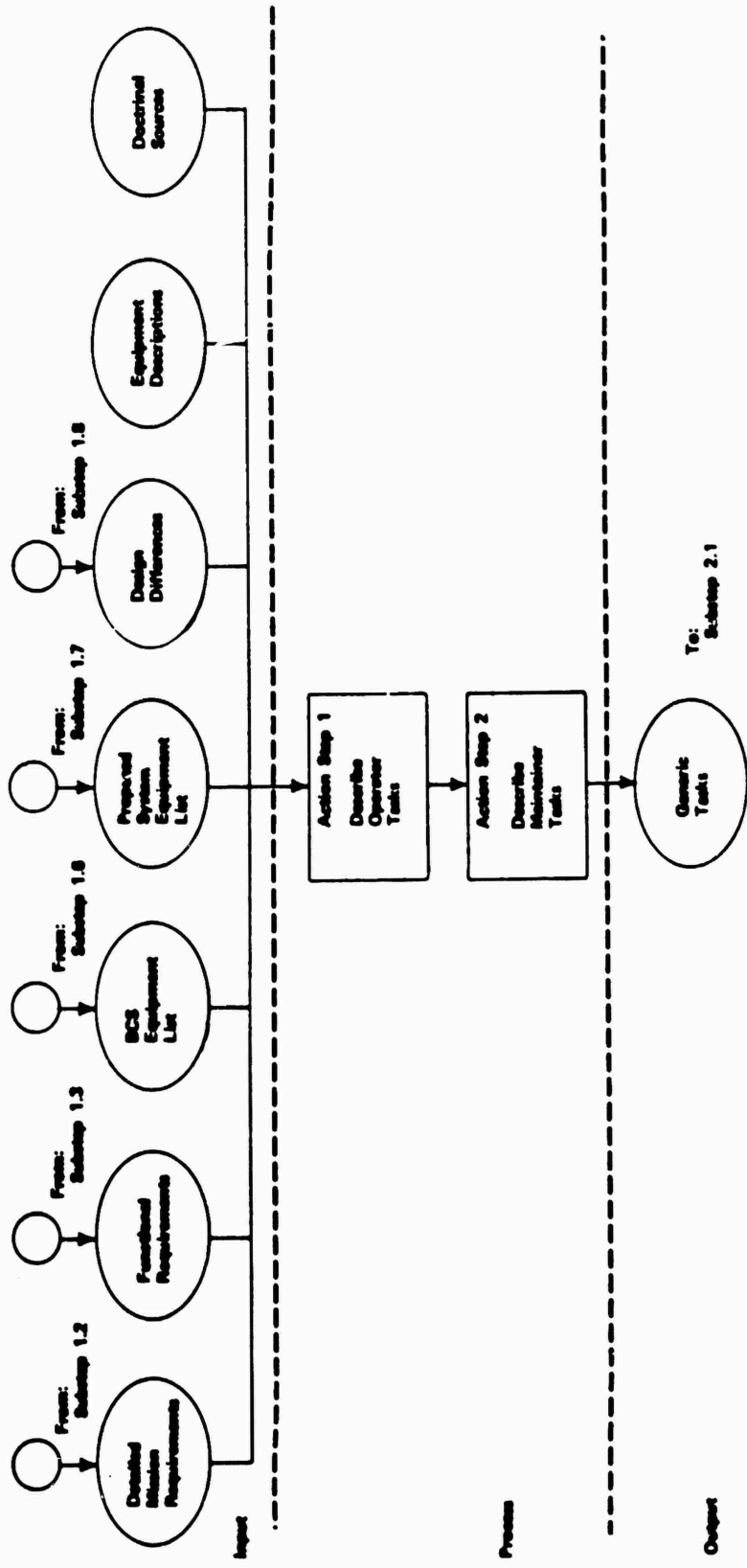

Figure 1E-1. Logic flow for Generic Task Identification.

This page intentionally left blank.

Substep 1.10/Overview

Determine Generic Tasks

Objective

The purpose of this step is to establish a generic set of tasks which will be performed by the operators and maintainers of the system under analysis. These tasks are termed "generic" because they should provide a common basis of understanding and an analytic departure point for subsequent manpower and training analyses.

The term "task" typically has different meanings to manpower and training analysts. Consequently, the language used to describe the generic tasks must be abstract enough so that both manpower and training analysts can relate to them. Determining generic tasks in this manner establishes the audit trail from both manpower and training analyses back to equipment, functional, and mission requirements of the system.

Input

Input from other HARDMAN substeps includes the detailed mission requirements from Substep 1.2, functional requirements from Substep 1.3, BCS and Proposed System equipment lists from Substeps 1.6 and 1.7, and the Design Difference Index developed in Substep 1.8.

The Design Difference Index indicates the variances between the BCS and Proposed Systems from Substep 1.8. Input from various sources includes technical manuals and other descriptions of the operation and maintenance requirements of equipment. Also consulted are field manuals and other doctrinal sources that describe human tasks not related to equipment.

Substep 1.10/Overview

Product

The product of this substep is a set of generic tasks for the system under analysis which will apply to both the BCS and Proposed Systems.

Logic

In HARDMAN, the term "task" refers to necessary system operations and maintenance activities which require human performance. Tasks exist in the middle of a continuum of analysis levels (see Table 1.10-1). Thus, tasks are the link between higher-level analyses of the system as a whole and lower-level analyses, such as those of training tasks.

Because manpower and training analyses view human performance from different perspectives, development of a common set or taxonomy of tasks is necessary.

The manpower analyst regards tasks primarily as a bookkeeping device for apportioning or accounting for system workload. The training analyst, on the other hand, views tasks as the basic objective of training.

It is at the task level that decisions are made about whether training is needed and, if training is needed, in what setting it is best conducted. Tasks, therefore, become the focus of training resource allocation and are the beginning point of the training development process.

Manpower analysis uses tasks that are located at the bottom of the hierarchy of system and subsystem missions and functions. Training analysis uses tasks placed above the behaviors captured by subtasks and task elements.

For example, the manpower analyst can assign workload to a task described as "Aim Cannon." The training analyst goes beyond this level to the cognitive and psychomotor behaviors required for successful task performance.

Thus, the requirement for a task description generic enough to suit both manpower and training analyses is satisfied by the higher level of abstraction associated with manpower tasks.

Figure 1E-1 represents the logic flow for determining generic tasks. Action Step 1 yields a description of operator tasks, while Action Step 2 results in a description of maintainer tasks.

Table 1.10-1. Analysis Levels

<u>Level/Object of Analysis</u>	<u>Purpose of Analysis</u>	<u>Example</u>
System	To determine effectiveness of the system in performing a specified mission	Self-propelled howitzer
Subsystem	To determine the best way to meet a specified requirement of the mission	Cannon
Function	To determine the best combination of components required to make up the system	Shoot
Task	To determine the best allocation of human capabilities in order to perform required functions	Load and Fire a Prepared Round
Sub-task	To determine the best use of human capabilities for accomplishing the assigned task	Fire Cannon
Element	To determine the best use of human capabilities in order to perform assigned sub-tasks	Attach Lanyard

Action Steps

Action Step 1: Describe Operator Tasks

Requirements In this action step, the analyst describes operator tasks using information system functional requirements and mission analyses.

Objective The purpose of this action step is to establish a comprehensive operator task list for the BCS and the Proposed Systems.

Procedures Tasks required for operation of both the BCS and the Proposed System are a function of each system alternative's specific equipment as well as its doctrinal requirements. Development of operator tasks for equipment is based on their operating characteristics. Operator tasks can be derived by inspecting relevant operator's manuals.

Other non-equipment-related operator tasks, especially those required for the functions of command and control and communicate, are more difficult to determine. Identification of these tasks requires greater analytical judgment and reliance on comparable weapon systems.

Typically, documentation on similar weapon systems within the same functional branch provides the greatest source of operator task information. Table 1.10-2 presents a sample list of operator action words that may be useful in developing operator tasks.

Table 1.10-2. Sample Operator Action Words

Activate	Detect	Listen for	Press	Stow
Adjust	Diagnose	Load	Pull	Synthesize
Aim	Direct	Locate	Push	Tighten
Allocate	Distinguish	Loosen	Raise	Trace
Arrange	Draft	Lubricate	Recognize	Track
Assemble/Dis-	Drive	Maneuver	Regulate	Transcribe
Assign	Energize/De-	March	Remove	Translate
Calculate	Evaluate	Mate	Replace	Troubleshoot
Categorize	Fire	Match	Respond	Tune
Check	Fly	Mix	Rotate	Turn on/off
Classify	Grasp	Monitor	Run	Twist
Clean	Group	Navigate	Schedule	Wait
Close/Open	Guide	Observe	Select	Watch
Collect	Identify	Operate	Service	Weld
Compute	Inspect	Order	Set up	Write
Connect/Dis-	Install	Pick	Sharpen	
Construct	Isolate	Pick up	Slide	
Control	Itemize	Pilot	Sort	
Coordinate	Lead	Plan	Specify	
Copy	Lift	Prepare	Stencil	

Action Step 2: Describe Maintainer Tasks

Requirement	In this action step, the analyst describes maintainer tasks using a generic set of maintenance action words and a generic equipment structure.
Objective	The purpose of Action Step 2 is to establish a comprehensive maintainer task list for the BCS and the Proposed Systems.
Procedures	Maintenance tasks required for both the BCS and the Proposed System are a function of the specific equipment and components selected for inclusion in the respective system concepts. The potential list of maintenance tasks is

the product of the number of unique items on the system equipment list (level of indenture, equipment breakdown structure) and the standard set of maintenance action verbs. (Several "standard" lists are available; see Table 1.10-3.)

The specific set of maintenance tasks required for a particular system concept is derived by deleting potential tasks which do not apply. They may not apply either because none is required, a particular task is not within the study's scope, or for other reasons.

The remaining tasks are required for the BCS and Proposed System and are expressed in verb-object form (e.g., "Repair Engine," "Replace Radio," etc.). The level of detail at which a task is stated depends strictly on the level of indenture (and hence detail) in the generic and Proposed System equipment structures).

Table 1.10-3. Sample Maintenance Action Words

<u>Sample Data Collection</u>	<u>AMC Pam 750-16</u>	<u>Maintenance</u>
Replace	Inspect	Inspect
Repair	Test	Test
Preventive	Service	Service
Adjust	Adjust	Purge
Other	Align	Adjust
	Calibrate	Remove and
	Install	Install
	Remove and	Replace
	Replace	Repair
	Repair	Overhaul
	Overhaul	Rebuild
	Rebuild	

Glossary

Action Rate The preventive maintenance action rate measured as the number of occurrences (i.e., demand) per life unit (calendar/clock time, miles/kilometers traveled, rounds fired or number of activations); (paraphrased from AR 570-2).

Additional Skill Identifier (ASI) A code added to the specialty/MOS to designate greater specialization (AR 351-1). For example, soldiers with either 11B, 12B, 19D MOS who receive Dragon Gunnery Training are assigned the ASI C2.

Administrative Time POI time allotted for administrative functions as opposed to course/training related functions.

Advanced Individual Training (AIT) Skill training given enlisted personnel after completion of basic training, so as to qualify them for the award of an MOS and to perform the basics of their job upon initial assignment to a unit (AR 351-1).

Noncommissioned Officer Course (ANCOC) A course that stresses MOS-related tasks with emphasis on technical and advanced leadership skills, and knowledge of military subjects required to train and teach other soldiers at the platoon and comparable level (AR 351-1).

Annex Logical divisions in a program of instruction (POI) that cluster tasks into blocks of instruction. Within each annex are lessons (identified by file numbers) which are designed to instruct the tasks.

Annual Accessions The number of individuals who must be recruited in a year.

Annual Costs Total cost of training computed on an annual basis.

Annual Course Costs Total course cost and individual course cost elements computed on an annual basis.

Annual Course Resources Products of Training Cost and Resources. Include number of instructors required, training cost, and training man-days.

Annual Instructor Requirements The number of instructors required to deliver all convenings of a course in a year.

Annual Training Man-Day Requirements Number of man-days per year that soldiers will be receiving a course of instruction and be unavailable for assignment to other duties.

Attrition Rate The rate at which individuals leave the Army at each paygrade within each MOS.

Audit Trail A systematic mechanism for tracking development of MPT requirements and for monitoring changes to the data, assumptions, or procedures which produce the MPT requirements.

Availability Ratio An estimate of availability of an MOS to support a Proposed System.

Base Operations Cost Cost to the base operations functional account adjusted by the total number of training man-weeks.

Baseline Comparison System (BCS) A current operational system, or a composite of current operational subsystems, which most closely represents the design, operational, and support characteristics of the new system under development (MIL-STD-1388-1A).

Basic Combat Training (BCT) Fundamentals of basic infantry combat given to enlisted Active Army and Reserve personnel without prior military service (AR 310-25).

Basic Noncommissioned Officer Course (BNCOC) A course that prepares career soldiers in Grade E5 (Skill Level 2) for duties at grade E6. Performance-oriented training is stressed (AR 351-1).

Basic Technical Course (BTC) A course that focuses on training critical tasks listed in the Skill Level 3 Soldier's Manual for a given MOS (AR 351-1).

Basis of Issue Plan (BOIP) A plan which indicates the quantity of new or modified equipment planned for each type organization and the planned changes to personnel and supporting equipment (AR 70-27).

Bill Payer An older system that is currently consuming MPT resources and that will be phased out of the inventory upon introduction of the new system.

Career Management Field (CMF) A list of operator or maintainer Military Occupational Specialties for one functional branch area.

Class Frequency Average number of times a Program of Instruction is offered each year (averaging across locations).

Class Length Length of a course of study, usually stated in weeks.

Comparability Analysis Process by which estimates of the human resource requirements of an emerging weapon system are derived from the known requirements of similar operational systems and subsystems.

Comparable Task The task closest to a new task in terms of task criticality and similarity to type or class of task.

Corrective Maintenance (CM) All actions performed as a result of failure to restore an item to a specific condition (MIL-STD-1388-1A).

Cost and Training Effectiveness Analysis (CTEA) The sole Army process used to assess the training cost and effectiveness of developing weapon systems.

Course Attrition The number of students failing to graduate from a course of instruction.

Course Number An alphanumeric code used to designate a Program of Instruction.

Course Module A component instruction which teaches a specific task; can exist at course, annex, or file level.

Course, System-Specific (1) The Advanced Individual Training (AIT) and Additional Skill Identifier (ASI) courses for all MOSs assigned to equipment in the Predecessor, Baseline Comparison, and Proposed Systems; and (2) the Noncommissioned Officer Education System (NCOES), warrant and commissioned officer courses providing direct instruction on system-specific equipment.

Crew Maintenance Maintenance actions that are performed by the personnel whose principal duty is operation of a system.

Critical Resources The implementation or management risk associated with the introduction of a new system. This risk

involves manpower, personnel, and training demands created by the new system compared to the present or projected supply.

Data Management Structure A systematic, consistent method of organizing information.

Delta The Greek letter; symbolizes an expected change in the manpower, personnel, and training requirements cited in output reports.

Dependency The relationship (dependency) between a specific maintenance action and a specific metric. For example, maintenance actions associated with automobiles usually depend on the number of miles driven, maintenance associated with an artillery tube depends on rounds fired, and electronic equipment depends on hours operated.

Depot Maintenance Maintenance involving the overhaul of economically repairable materiel to augment the procurement program in satisfying the overall Army requirements and when required to provide for repair of materiel beyond the capability of general support maintenance organizations (AR 310-25).

Design Differences Differences in design between projected equipment and comparable existing equipment used in the Baseline Comparison System.

Design Freedom The absence of a detailed design at the beginning of a weapon system's development.

Direct Cost Operational and Maintenance, Army (OMA), Military Personnel, Army (MPA) and Procurement Account (PA) cost elements that are directly contributable to the cost per graduate for a specific course or group of courses. The following direct costs are listed in TRADOC Cost Analysis Program Reports (MOS Training Costs), ATRM-159 (R1): direct mission, troop support, ammunition, equipment item depreciation, student pay and allowances, travel pay to course, per diem at course.

Direct Maintenance Effort expended by maintenance personnel in the actual performance of maintenance on the hardware in accordance with the prescribed procedures contained in the applicable technical manuals (DA PAM 700-127).

Direct Mission Cost Operational and Maintenance, Army (OMA) and Military Personnel Army (MPA) cost of the instructional

department's costs, plus the flying hours costs plus any other costs all computed on a per graduate basis. Algorithms for computing these costs are contained in Cost Analysis Program Reports (MOS Training Costs) ATRM-159 (R1) documents.

Direct Support Maintenance (DS) Normally authorized and performed by designated maintenance activities in direct support of using organizations. This category of maintenance is limited to the repair of end items or unserviceable assemblies in support of using organizations on a return to user basis (AR 310-25).

Duty Position A group of closely related tasks and responsibilities which are normally assumed by one individual (AR 310-25).

End-Item Equipment A final combination of end item products, components, parts and/or materials that is ready for its intended use, e.g., ship, tank, mobile machine shop, aircraft (MIL-STD-1388-1A).

Engineering Comparability Analysis A structured analytic process utilizing principles of reliability/maintainability (R/M) engineering, logistics engineering, industrial engineering, and statistical extrapolation to predict the reliability and maintainability of new systems based upon the R/M characteristics of existing systems.

Environmental Variables Environmental factors such as heat, cold, snow, mud, desert conditions, etc., which may impact the operating scenario of the proposed weapon system.

Equipment Depreciation Cost Cost of equipment dedicated to a course, non-dedicated departmental equipment, and school overhead equipment amortized over a ten-year period and applied to Course Cost.

Equipment Identification Code (EIC) An alphanumeric coding scheme used to identify specific pieces of equipment. May equate to Functional Group Codes, Work Unit Codes, or Logistic Support Analysis Record numbers.

File The lessons within an annex of a program of instruction (POI) in which tasks are taught.

First Unit Equipped (FUE) The first troop unit to be equipped with the first production items/systems (DA PAM 700-127).

Footprint The resources of an earlier system within which a new system must fit or closely match.

Frequency The number of times the task is performed per period of time.

Front-End Analysis The process of assessing what impacts the manpower, personnel, and training requirements of an emerging system will have on present and projected resources.

Function A broad category of activity performed by a man-machine system (Draft MIL-STD on Task Analysis, Feb. 1980). For example, upper level functions of a self-propelled howitzer would be to shoot, move, and communicate. The requirement to shoot would have lower level functions such as direct and indirect fire.

Functional Allocation The categorization of the activities (functions) performed by a man-machine system into who or what will perform them. The performance categories include hardware, software, human (operator, maintainer, or support), or a combination of these.

Functional Group Code (FGC) A standard indexing system which parcels the weapon system into its functional systems, subsystems, components/assemblies, and parts.

Functional Hierarchy Functional structure which first identifies the major functions and subsequently each of the lower level functions a system is expected to perform. These functions are arranged in a hierarchical structure to aid in the identification of components from which lower level functions and their sequence are determined and described.

Functional Requirements Functions or activities required of a proposed weapon system. These required functions are developed and stated in DoD and Army threat studies, mission area analyses, how-to-fight manuals, use studies, and system concept papers.

General Support Maintenance (GS) The maintenance authorized and performed by designated Table of Organization and Equipment (TOE) and Table of Distribution and Allowance (TDA) organizations in support of the Army Supply System. Normally, these organizations will repair or overhaul materiel to required maintenance standards in a

ready-to-issue condition based upon applicable supported Army area supply requirements (AR 310-25).

Generic System A description of the general configuration of equipment, software, and duty positions required to fulfill all system functional requirements stated in Army Mission Area Analyses and System Concept Papers.

Hardware Function An activity (function) accomplished principally by the equipment.

High Driver A system element which consumes a large proportion of MPT resources.

Indirect Cost A cost which, because of its incurrence for common or joint objectives, is not readily subject to treatment as a direct cost (AR 310-25).

Indirect Maintenance Also stated as Indirect Productive Time (IPT); the time required for normal performance of the maintenance tasks but that does not in and by itself result in the total time required to accomplish the tasks. Indirect maintenance will not exceed a ratio of 1 to 0.4 (direct to indirect) for organizational and direct support maintenance. For general support, indirect maintenance will not exceed a ratio of 1 to 0.22 (direct to indirect).

Individual and Collective Training Plan (ICTP) The primary resource and planning document for developing training subsystems for new Army systems. The ICTP describes the integration of training subsystems into the development of the total system as well as integration of the developing system into ongoing training programs.

Individual Work Capacity The available productive man-hours (available for MOS duties). Excludes all non-available time factors such as security, kitchen patrol, work details, messing, casualties, personal needs, and unit movement (AR 570-2).

Induced Maintenance See Unscheduled Maintenance, Induced.

Inherent Maintenance See Unscheduled Maintenance, Inherent.

Instructional Department Cost Includes Operations and Maintenance, Army (OMA) and Military Personnel, Army (MPA) costs of the academic department's cost per graduate. It also includes pay and allowances of instructors and academic department staff, consumable supplies and equipment, and

contractual services. The method used to compute Instructional Department Cost can be found in the Cost Analysis Program (MOS Training Costs) documents [ATRM-159 (R1)].

Instructional Systems Development A systems engineering approach to developing a training program based on task analysis. ISD includes five phases: analyze, design, develop, implement, and control.

Instructor Contact Hours (ICH) Instructor manhours required to present course material and to provide assistance to students during the actual presentation of course of instruction (DA PAM 570-558).

Intake to Paygrade The number of individuals who must be assessed or promoted into a paygrade.

Line Item Number A number identifying the position which end-line equipment or a component thereof holds in the equipment hierarchy.

Logistic Support Analysis An analysis supplied during the acquisition process in order to insure supportability and other Integrated Logistic Support (ILS) objectives. The analysis consists of iterative definition, synthesis, tradeoff, and test/evaluation (MIL-STD-1388-1A).

Maintainability A system's or its component's requirement for maintenance, both planned and corrective determines its maintainability. Maintainability is a product of the frequency of planned maintenance actions and corrective maintenance actions multiplied by the time these actions take to complete.

Maintenance, Corrective See Corrective Maintenance.

Maintenance Level The four basic levels of maintenance into which maintenance activity is divided. They include organizational, direct support, general support, and depot (DA PAM 700-127).

Maintenance Manhours Per Maintenance Action A measure of the maintainability parameter related to item demand for maintenance manpower: the sum of maintenance man-hours divided by the total number of maintenance actions (preventive and corrective) during a stated period of time (MIL-STD-721C).

Maintenance, Preventive See Preventive Maintenance.

Maintenance Ratio A measure of the total maintenance manpower burden required to maintain a system. It is expressed as the cumulative number of manhours of maintenance expended in direct labor during a given period of time divided by the cumulative number of end items' operating hours during the same time (DA PAM 700-127).

Manpower The total demand, expressed in terms of the number of individuals, associated with a system. (MIL-STD-1388-1A). Includes the number of individuals in each MOS/ASI, skill level, and paygrade required to operate and maintain a system.

Manpower Losses Per Year Losses in productive manpower at each paygrade in an MOS due to promotion, attrition, and application of the Transients, Trainees, Holders, and Students (TTHS) percentage to the manpower requirements over the course of a year.

Manpower Requirements An emerging weapon system's qualitative and quantitative manning needs.

Manpower Requirements Criteria (MARC) The manpower requirements of positions for Army units as defined in AR 570-2.

Mean Time to Repair (MTTR) A basic measure of maintainability. MTTR is calculated by summing corrective maintenance actions times for a particular item and dividing this sum by the total number of failures of that item at a specified maintenance level.

Military Occupational Specialty (MOS) A group of duty positions that require closely related skills such that a person qualified in one duty position in an MOS can, with adequate on-the-job training (OJT), perform in any of the other positions that are at the same level of difficulty.

Military Occupational Specialty Code (MOSC) A specific occupational identification identifying type and level of skill, level of proficiency, and/or scope of responsibility (AR 611-201); stated in terms of MOS and skill level.

Military Personnel, Army (MPA) An appropriation that provides for pay, allowances, individual clothing, subsistence, interest on deposits, gratuities, permanent change of station travel, per diem portion of temporary duty travel between permanent duty stations for members of the

Army on active duty and military academy cadets. Also includes expenses of apprehension and delivery of deserters, prisoners, and members absent without leave (AR 37-100-80).

Mission A clear, concise statement of a task or tasks to be accomplished.

Mission Area A broad subdivision of the Army's overall mission, which is to prepare for, engage in, and win land wars.

Mission Area Analysis Process by which a threat is analyzed and a counter to this threat (i.e., the mission) is postulated. The mission is stated in the Mission Area Analysis's Studies and System Concept Papers.

Characteristics Threat and environment impacts define specific mission characteristics. Frequently, mission characteristics require specific performance requirements of a system.

Mission Name Name assigned to a specific mission that a system is expected to accomplish. For example, Defeat Enemy Armor is a mission that could be assigned to armored units, aviation units, and infantry equipped with anti-armor systems.

Mode/Concept Details the maintenance concept, organizational concept, and the operational mode/concept proposed for a system. Firing 40 rounds per hour, moving three times a day, fixing forward, and performing all organizational maintenance actions within 30 minutes are examples of modes and concepts.

New Technologies The additional technologies (in addition to technologies incorporated in current systems) that a system needs to meet stated performance requirements.

Normalized Graduates The number of students who satisfactorily completed the course (graduate), as adjusted for carryovers. Norm grads equal the number of actual grads minus one-half the number of students in training in the beginning of the fiscal year plus one-half the number of students in training at the end of the fiscal year.

Number of Acquisitions The total number of systems to be purchased. Includes TOE as well as systems purchased for Reserve Forces and operational floats. Also includes systems purchased to be pre-positioned but not manned.

One-Station Unit Training (OSUT) Training conducted at one location; includes both basic and advanced individual training for combat arms MOS and selected combat support MOS. Training is conducted in one unit with the same cadre and one program of instruction (POI) (AR 351-1 and PM 25-1).

Operating Strength The present and absent strength of an organization classified under the item "personnel status" of the morning report heading as "permanent party". Does not include "intransit" strength (AR 310-25).

Operational Environment Characteristics Environmental and operational factors that will impact the operating scenario of the proposed weapon system. Includes environmental variables as well as operational and scenario dependent variables such as smoke, NBC, and night operations.

Operational Manning (OM) The number of personnel required to operate a system in an operational environment.

Operations and Maintenance, Army (OMA) An appropriation that provides for the operation and maintenance of all organizational equipment and facilities of the Army; procurement or requisite equipment and supplies; production of audiovisual instructional materiel and training devices; operation of service-wide and establishment-wide activities; operation of depots, schools, training, and programs related to the operation and maintenance of the Army (AR 37-100-80).

Optimum Class Size The number of students designated for a class which, due to instructional considerations, is considered optimum.

Organizational Maintenance (ORG) Maintenance authorized for and performed by a using organization on its own equipment (AR 310-25).

Paygrade (PGD) The statutory paygrade established in the Career Compensation Act of 1949, as amended (AR 310-25).

Per Diem at Course The students' daily expenses which are costed for courses that are less than twenty weeks in length [ATRM-159 (R1)].

Performance Measure The qualitative description of how the function's performance will be assessed.

Performance Standard An established number of man-hours needed to accomplish a unit of work (AR 310-25).

Period Reported The period of time, in days, that the system is to maintain continuous operation and for which workload and manpower requirements are to be determined.

Personnel Flow Rates The rates of progression of individuals through the military personnel system. Includes promotion, attrition, and TTHS rates.

Personnel Pipeline The personnel structure that must be maintained to insure that required manpower requirements are met.

Personnel Requirements The number of people who must be carried in a personnel pipeline to satisfy stated manpower requirements. This number must also offset manpower losses that result from attrition, advancement, and non-availability.

Perturbation Value A quantitative representation of the impact of the design differences between the Baseline Comparison System and the Proposed System.

Phased Schedule A schedule that lists the number of new systems to be placed in service per year.

Planned or Estimated Schedule The planned or estimated schedule for a new system progressing through the acquisition process.

Predecessor System An Army system that is performing mission(s) that will eventually be performed by the new system.

Prepositioned Materiel Configured to Unit Sets (POMCUS) Equipment that has been procured but is held, unmanned, in readiness for future use.

Preventive Maintenance (PM) All actions performed in order to retain an item in specified condition. Involves systematic inspection, detection, and prevention of incipient failures (MIL-STD-1388-1A).

Primary Leadership Course (PLC) A leadership, supervisory, and management course built around the environment in which combat support/combat service support leaders perform their duties (AR 351-1).

Primary Noncommissioned Officer Course (PNCOC) A non-MOS specific, field-oriented course built around basic soldier

skills and tasks that prepares E4 soldiers for duties at the E5 level (AR 351-1).

Primary Technical Course (PTC) A course that focuses on training critical tasks listed in the Skill Level 2 Soldier's Manual for a given MOS. Training is provided in resident and extension modes.

Procurement Appropriation (PA) Five continuing (multi-year) appropriations that provide funds for procurement, manufacture, and conversion of major items of combat and support equipment, including ammunition, aircraft, missile systems, weapons, combat and support vehicles.

Program of Instruction (POI) The training management document that specifies the purpose, prerequisites, content, duration, and sequence of instruction for normal resident and non-resident courses (AR 310-25).

Promotion Rate The rate at which individuals advance from one paygrade to another.

Proposed System An analytic construct used to determine the functional requirements of a new system. It incorporates the technological advances likely to exist before the system's projected initial operational capability date.

Quasi-Program of Instruction A partial program of instruction designed to evaluate the impact of emerging system designs on existing courses of instruction. It also helps determine requirements for new courses of instruction.

Reliability Can be defined as (1) the duration or probability of failure-free performance under stated conditions, or (2) the probability that an item can perform its intended function for a specified interval under stated conditions (MIL-STD-1388-1A).

Reliability, Availability, Maintainability (RAM) A measure of reliability or maintainability that includes the combined effects of item design, quality, installation, environment, operation, maintenance, and repair (AR 702-3).

Replacement Year Year when the predecessor system is scheduled to be totally replaced by the new system.

Scope See Scope, System.

Scenario A brief description of the theater, environment and

threat factors that are likely to be associated with the system missions.

Scenario Usage Rate The utilization rate that is the planned or actual number of life units expended or missions attempted during a stated interval of time (MIL-STD-721C). Life unit is the duration of applicable use, i.e., operating hours, cycles, distance, rounds fired.

Scheduled Maintenance Preventive maintenance performed at prescribed points in the item's life (MIL-STD-1388-1A).

Scheduled Unit Training Training of an entire unit that occurs at regularly scheduled times. Unit training provides reinforcement of previous training as well as new training in group and unit tasks.

Self-Study Individual study by which the soldier learns new skills or reinforces skills already learned (AR 350-1).

Senior Noncommissioned Officer Course (SNCO) Senior level training that prepares soldiers in grades E8 and E9. It consists of resident and extension training as well as on-the-job experience (AR 351-1).

Sergeants Major Academy (SGMA) The capstone of enlisted training. Master and first sergeants (E-8) are prepared for high-level responsibilities in both troop and senior staff assignments (AR 351-1).

Service School Institutional training, either individual or collective, conducted in Army schools or Army training centers; uses instructional systems development materials.

Skill Level (1) Level of proficiency required for performance of a specific military job, (2) the level of proficiency at which an individual qualifies in that military occupational specialty (AR 351-1).

Student Pay and Allowance Cost Weekly rate of pay for the model grade of a student based upon the Composite Standard Rates for Existing Military Personnel Services (AR 37-108). This weekly rate multiplied by the course length in weeks is used to compute cost per graduate [ATRM-159 (R1)].

Supervised On-the-Job Training Structured training accomplished while a person is working in a particular skill level and MOS (AR 351-1).

Support Cost That portion of total indirect cost not included in base operations cost per graduate. These are installation costs that include training aids, base communications, medical, and family housing on a pro-rate share of school's military man-years (MMY) supported as a percent of the total benefiting tenant MMY [ATRM-159 (R1)].

System The combination of people, hardware, and information which, when interacting as a whole, is capable of performing a required mission on the battlefield.

System Functional Requirement The attributes or capabilities required to be present in the system elements so that each element and the system as a whole can accomplish assigned actions.

System Scope A precise definition of the range and depth of a weapon system, including (1) number of missions assigned, (2) number of materiel commodities incorporated, and (3) number of distinct platforms and/or components comprising the system.

System Density The quantity of systems requiring maintenance and supply support in a unit, group of units, or at a maintenance level. Stated in terms of the Basis of Issue for units.

System Performance Goals A description of the goals that must be achieved for each system performance measure.

System Performance Measures Measures that describe the performance capabilities that must be achieved for each system function. System performance measures usually consist of speed, rate of fire, etc.

Systems Analysis An orderly approach to helping a decision maker choose a course of action. Its basis is a model or idealized description of the situation under analysis.

Table of Organization and Equipment (TOE) A table that prescribes the normal mission, organizational structure, personnel, and equipment requirements for a military unit. It forms the basis for an authorization document (AR 310-25).

Task A unit of work activity that constitutes a logical and necessary step in the performance of a job/duty. It is the smallest unit of behavior in a job that describes the performance of a meaningful function in the job under consideration.

Task Description Concise wording, usually verb-object form, that describes a task.

Task Number A numerical code used to designate a task.

Threat Characteristics The specifics of an enemy threat as determined in a Threat Analysis and stated in a Threat Study (see also Mission Analysis and Mission Characteristics).

Threat Variables The range and complexity an enemy threat can take. Includes the consideration given in a Threat Analysis to the compounding of threat that a new enemy capability can have in concert with other new or existing threats. Also includes consideration of current weakness in countering the new and combined enemy threat.

Training Aids Cost Cost of installation-support training aids adjusted by the total number of training man-weeks.

Training Man-Days The length of class time needed to train an individual student in a course.

Training Resource Requirements Analysis (TRRA) A process used to estimate systematically the training requirements for Army weapon systems during the earliest phases of their development. These requirement estimates include specification of the system's task, course, and resource requirements.

Transients, Trainees, Holders, and Students Rates (TTHS) The percentage of personnel in a paygrade who are unassignable and are therefore unable to contribute to the work associated with the weapon system.

Travel Pay to Course The travel cost per graduate computed on a standard cost per mile. The cost per mile is multiplied by a class average one-way mileage, which is obtained from a sample of student records.

Type of Instruction Type of instruction used for a training course. Typical categories are conference, demonstration, practical exercise, etc. (TRADOC CIR 351-12).

Unscheduled Maintenance, Inherent Those maintenance actions (or events) necessary for restoring an item to a specified condition when the failure has been caused by a condition resulting from an inherent fault in design or strength of material specified.

Unscheduled Maintenance, Induced Those maintenance actions (or events) necessary for restoring an item to a specified condition when the failure has been induced by a condition (including environmental) not resulting from an inherent fault of an item.

Unscheduled Maintenance, Other Those maintenance actions (or events) necessary for restoring an item to a specified condition that was not caused directly by induced or inherent failures. Causes include removal to gain entry, cannot duplicate reported discrepancy, cannibalization, unscheduled inspections, etc.

Workload The amount of work, stated in predetermined work units, that organizations or individuals perform or are responsible for performing (AR 310-25).

This page intentionally left blank.

References

Andrews, Walter (1983, March 16). Weapons maintenance seems costly. Washington Times.

Army Science Board (1980). Ad Hoc study group on human issues. Department of the Army, Assistant Secretary of the Army Research, Development and Acquisition. Washington, DC.

Baker, James D., and Shields, J. (1981, May). Personnel affordability: The Army's odyssey into the year 2000. Paper presented at ORSA/TIMS Meeting, Toronto, Canada.

Chief of Naval Materiel (series). Ship's maintenance and materiel management program (OPNAVIST 4790.4). Washington, DC.

Chief of Naval Materiel, Ship's Parts Control Center (series). Consolidated shipboard allowance list preparation. Washington, DC

Chief of Naval Operations (1979). Application of the HARDMAN comparability methodology to VTXTS flight vehicle maintenance manpower requirements. Office of CNO, HARDMAN Project Office (OP-112C) Contractor: Dynamics Research Corporation, Contract No. N61339-80-D005.

Chief of Naval Operations (1980). HARDMAN methodology handbook, Vol. II: User's manual preliminary draft. Office of CNO HARDMAN Project Office (OP-112C). Contractor: Dynamics Research Corporation, Contract No. N61339-80-D005. Washington, DC.

Chief of Naval Operations (1983). HARDMAN methodology handbook (draft). Office of CNO HARDMAN Project Office (OP-112C). Contractor: Dynamics Research Corporation, Contract No. N61339-80-D005. Washington, DC.

Coleman, Herbert J. (1981, February 16). Weapons maintainability guidance sought by GAO. Aviation Week & Space Technology.

Cushman, Jack (1981, July 27). Troublesome tank: TAO still unhappy with M-1 results. Defense Week.

Department of the Air Force (1975). Air Force audiovisual directory (AFR 95-2). Washington, DC

Department of the Air Force (1982). Airman specialty vehicle mechanic (AFR 39-1). Washington, DC.

Department of the Air Force (1979). Maintenance management policy (AFM 66-1). Washington, DC.

Department of the Air Force (1984). USAF formal schools (AFR 50-5). Washington, DC.

Department of the Army (1984). Army personnel selection and classification: Enlisted career management fields and military occupational specialties (AR 611-201). Washington, DC.

Department of the Army (1981). Basic policies for systems acquisition. Washington, DC.

Department of the Army (quarterly). Chief of Personnel Operations 45 Report (COPO 45 Report). Washington, DC.

Department of the Army (1968). Combat, tactical, and support vehicles and special-purpose equipment (TB 750-93-1). Washington, DC.

Department of the Army (1984). Consolidated index of Army publications and blank forms (DA Pam 310-1). Washington, DC.

Department of the Army (1982). Consolidated MOS catalog (DA Pam 350-100). Washington, DC.

Department of the Army (1979). Dictionary of United States Army terms (AD)(AR 310-25). Washington, DC.

Department of the Army (1981). EPMS master training plan (DA Pam 351-9). Washington, DC.

Department of the Army. Extension training material catalogs (series) (DA Pam 350-XXX-X). Washington, DC.

Department of the Army (1981). Field artillery battalion, lance (DA Pam 350-106-3). Washington, DC.

Department of the Army (1981). Field artillery units, 155mm self-propelled (DA Pam 350-106-4). Washington, DC.

Department of the Army (1983). Fire support in combined arms operation (FM 6-20). Washington, DC.

Department of the Army (1973). Guide for using existing programmed structural materials (DA Pam 690-22). Washington, DC.

Department of the Army (1980). Index and description of Army training devices (DA Pam 310-12). Washington, DC.

Department of the Army (1979). Index of Army motion pictures and related audio-visual aids (DA Pam 108-1). Washington, DC.

Department of the Army (1980). Index of doctrinal, training, and organizational publications (DA Pam 310-3). Washington, DC.

Department of the Army (1979). Integrated logistic support management model and glossary (DA Pam 700-127). Washington, DC.

Department of the Army (1975). Life cycle system management model for Army systems (DA Pam 11-25). Washington, DC.

Department of the Army (1983). Manpower and equipment control: Organization and equipment requirements tables (AR 570-2). Washington, DC.

Department of the Army (1969). Organization and equipment authorization tables: Personnel (AR 570-2DA). Washington, DC.

Department of the Army (1980). Reliability and maintainability (AR 702-3). Washington, DC.

Department of the Army (1982). Sample data collection: The Army maintenance management system (AR 750-37). Washington, DC.

Department of the Army (1979). Staffing guide for US Army service schools (DA Pam 570-558). Washington, DC.

Department of the Army (1983). US Army correspondence course program catalog (DA Pam 351-20). Washington, DC.

Department of the Army (1984). US Army formal schools catalog (DA Pam 351-4). Washington, DC.

Department of Defense (1983). Acquisition and management of integrated logistic support for systems and equipment (DoD Directive 5000.39). Washington, DC.

Department of Defense (1983). Major system acquisition procedures (DoD Directive 5000.2). Proposed revision, October 30, 1982; March 8, 1983. Washington, DC.

Department of Defense (1982). Major system acquisition (DoD Directive 5000.1). Washington, DC.

Department of Defense (1983). Logistic support analysis (MIL-STD-1388-1A). Washington, DC.

Department of Defense (1983). Logistic support analysis record data elements and requirements (MIL-STD-1388-2A). Washington, DC.

Department of Defense (1975). Work breakdown structure for defense materiel items (MIL-STD-881A). Washington, DC.

DePuy, William, E. and Bonder, Seth (1982). Integration of MPT supply and demand and system acquisition process. US Army Research Institute, Research Note 82-1. Washington, DC.

Eckstrand, Gordon A. (1980, October). Product support -- A changing challenge. Manpower Factors in System Acquisition Aerospace Industries Symposium. Seattle, WA.

Eckstrand, G. (1980, August) Technology projection: Manpower and logistics factors in weapon system development. NTIS.

Kerwin, Gen. Walter T. and Blanchard, George S. (1980, August). Man/machine interface -- A growing crisis. U.S. Army Materiel Systems Analysis Activity.

Kuhn, George W.S., (1983). Ending defense stagnation. In Richard N. Holwill (Ed.), A mandate for leadership report -- Agenda '83. The Heritage Foundation.

Office of Management and Budget (1976). Major systems acquisition (OMB Cir A-109). Washington, DC.

Quade, E.S. (1975). Analysis for public decisions. Elsevier Science Publishers. New York.

Ritchie, M. (1974, February). Manpower implications in the design of Air Force equipment. NTIS.

Smith, CPT John (1984, March/April). HARDMAN: New asset for TRADOC systems managers. Soldier Support Journal.

US Air Force Audio-Visual Services (1980). USAF audio-visual resources and functions (AFR 95-1). Norton AFB, CA.

US Air Force Human Resources Laboratory (1982). ASSET user's guide (application). Contractor, Westinghouse Electric Corporation, Contract No. F33615-79-C-0330.

US Air Force Logistics Command (1980). USAF Maintenance Management (AFM 66-1). Andrews AFB, MD.

US Air Force Manpower Personnel Center (1982). Airman Classification Regulation (AFR 39-1). Randolph AFB, TX.

US Air Force Manpower Personnel Training Section (1981). USAF Formal Schools Catalog (AFR 50-5). Randolph AFB, TX.

US Army Materiel Command/Training and Doctrine Command (1982). Reliability, availability, and maintainability rationale report handbook (AMC/TRADOC Pam 70-11). Fort Monroe, VA.

US Army Soldier Support Center (1984). "What to do" booklet: A road map for addressing MPT in the acquisition process. Alexandria, VA.

US Army Training and Doctrine Command (1983). Armywide training and doctrinal literature (TRADOC Pam 310-3). Fort Monroe, VA.

US Army Training and Doctrine Command (1981). Combat developments studies (TRADOC Reg 11-8). Fort Monroe, VA.

US Army Training and Doctrine Command (1980). Common job and task management (TRADOC Cir 351-1). Fort Monroe, VA.

US Army Training and Doctrine Command (1984). Cost analysis program (MOS/FMS) training costs (TRADOC Reg 11-5). Fort Monroe, VA.

US Army Training and Doctrine Command (1976). Educational video tape catalog (TRADOC 350-33). Fort Monroe, VA.

US Army Training and Doctrine Command (1983). ICH computation worksheet (TRADOC Form 377-R). Fort Monroe, VA.

US Army Training and Doctrine Command (1979). Job and task analysis handbook (TRADOC 351-4). Fort Monroe, VA.

US Army Materiel Command/Training and Doctrine Command (1984). Materiel acquisition handbook (AMC/TRADOC Pam 70-2). Fort Monroe, VA.

US Army Training and Doctrine Command (1982). Training devices for Armywide use (TRADOC 71-9). Fort Monroe, VA.

US Army Training and Doctrine Command (1984). Training requirements analysis system (TRAS) (TRADOC Reg 351-1). Fort Monroe, VA.

US Army Training Support Center (1981). US Army comprehensive plan for training devices. Fort Eustis, VA.

US Marine Corps (1981). Marine Corps formal schools catalog (MCO P1500.12L). Washington, DC.

US Marine Corps (1982). MOS manual (MCO P11200.70). Washington, DC.

US Naval Education and Training Command (1984). Catalog of Navy training courses (CANTRAC) (NAVEDTRA 10500).

US Naval Military Personnel Command (1976). Manual of Navy enlisted manpower and personnel classifications and occupational standards, Sections I (updated semiannually) and II (updated quarterly).

Zimmerman, W., Butler, R., Grey, V., Rosenberg, L., and Risser, D. (1984, July). Evaluation of the HARDMAN comparability methodology. ARI Technical Report (Draft). Washington, DC.

References by Number

AMC/TRADOC Pam 70-2	Materiel Acquisition Handbook
AFM 50-5	USAF Formal Schools Catalog
AR 570-2	Manpower and Equipment Control: Organization and Equipment Requirements Tables
AR 611-201	Army Personnel Selection and Classi- fication -- Enlisted Career Manage- ment Fields and Military Occupational Specialties
AR 702-3	Reliability and Maintainability
AR 750-37	Sample Data Collection: The Army Maintenanc Management System
Ar 1000-1	Basic Policies for Systems Acquisition
ATRM 159	MOS Course Cost Report
COPO 45 Report	Chief of Personnel Operations 45 Report (published quarterly by MILPERCEN)
DA Pam 11-25	Life Cycle System Management Methods for Army Systems
DA Pam 108-1	Index of Army Motion Pictures and Related Audio-Visual Aids
DA Pam 310-1	Consolidated Index of Army Publications and Blank Forms
DA Pam 310-12	Index and Description of Army Training Devices
DA Pam 350-100	Consolidated MOS Catalog
DA Pam 350-XXX-X	Extension Training Material Catalogs (series)
DA Pam 351-4	U.S. Army Formal Schools Catalog

DA Pam 351-9	EPMS Master Training Plan
DA Pam 351-20	Army Correspondence Course Program Catalog
DA Pam 570-558	Staffing Guide for U.S. Army Service Schools
DA Pam 690-22	Guide for Using Existing Programmed Instructional Materials
DA Pam 700-127	Integrated Logistic Support Management Model and Glossary
FM 6-20	Fire Support in Combined Arms Operation
MCO P11200.7D	MOS Manual
MCO P1500.12K	Marine Corps Formal Schools Catalog
MIL-STD 881	Work Breakdown Structure for Defense Materiel Items
MIL-STD 1388-1A	Logistics Support Analysis
MIL-STD 1388-2A	LSAR Data Elements and Requirements
NAVEDTRA 10500	Catalog of Navy Training Courses (CANTRAC)
NAVPERS 18068D	Manual of Navy Enlisted Manpower and Personnel Classifications and Occupational Standards, Sections I (updated semiannually) and II (updated quarterly)
NMSOINST 4790.2	Integrated Logistic Support Instruction
OMB Cir A-109	Major Systems Acquisition
OPNAVIST 4790.4	Ship's Maintenance and Materiel Management Program
SPCCINST 4790.4	Consolidated Shipboard Allowance List Preparation
TB 750-93-1	Functional Grouping Codes: Combat, Tactical, and Support Vehicles and Special-Purpose Equipment

TRADOC Cir 351-1	Common Job and Task Management
TRADOC Form 377-R	ICH Computation Worksheet
TRADOC Form 812-R	Cost Analysis Program MOS/FMS Training Costs
TRADOC Pam 71-9	Catalog of TASO Training Devices
TRADOC Pam 310-3	TRADOC Armywide Training and Doctrinal Literature
TRADOC Pam 350-33	Educational Video Tape Catalog
TRADOC Pam 351-4	Job and Task Analysis Handbook
TRADOC Reg 11-5	Cost Analysis Program (MOS/FMS) Training Costs
TRADOC Reg 11-8	Combat Development Studies
TRADOC Reg 351-1	Training Requirements Analysis System (TRAS)
TRADOC/AMC Pam 70-11	Reliability, Availability, Maintain- ability Rationale Report Handbook

This page intentionally left blank.

Acronyms and Abbreviations

A

AETIS	Army Extension Training Information System
AFB	Air Force Base
AFHRL	Air Force Human Resources Laboratory
AFLC	Air Force Logistic Command
AFM	Air Force Manual
AFMPC	Air Force Military Personnel Center
AFR	Air Force Regulation
AFSC	Air Force Specialty Code
AIT	Advanced Individual Training
AMC	Army Materiel Command
ANCOC	Advanced Noncommissioned Officer Course
AOSP	Army Occupational Survey Program
AR	Army Regulation
AR	Availability Ratio
ARI	Army Research Institute
ARTEP	Army Training and Evaluation Program
ASARC	Army System Acquisition Review Council
ASI	Additional Skill Identifier
ASSET	Acquisition of Supportable Systems Evaluation Technology
ASVAB	Armed Services Vocational Aptitude Battery

ATRM	Army TRADOC Resource Management
ATRRS	Army Training Requirements and Resources System
ATSC	Army Training Support Center

B

BCS	Baseline Comparison System
BITE/PITE	Built-In/Plug-In Test Equipment
BNCOC	Basic Noncommissioned Officer Course
BOI	Basis of Issue
BOIP	Basis of Issue Plan
BTC	Basic Technical Course

C

CANTRAC	Catalog of Navy Training Courses
CD	Combat Developer
CDB	Consolidated Data Base
CDRL	Contract Deliverable Line Item
C-E	Concept Evaluation
CFE	Contractor-Furnished Equipment
CHRT	Coordinated Human Resource Technology
CMF	Career Management Field
CM	Corrective Maintenance
CNET	Chief of Naval Education and Training

CNATRA	Chief of Naval Air Training
CNM	Chief of Navy Materiel
CNMPC	Chief of Naval Military Personnel Command
CNO	Chief of Naval Operations
CNTECHTRA	Chief of Naval Technical Training
CODAP	Comprehensive Occupational Data Analysis Program
COEA	Cost and Operational Effectiveness Analysis
COI	Course of Instruction
COMTRALANT	Commander, Training Command, Atlantic
COMTRAPAC	Commander, Training Command, Pacific
COPO	Chief of Personnel Operations
COR	Contracting Officer's Representative
COTR	Contracting Officer's Technical Representative
CPU	Central Processing Unit
CSWS	Corps Support Weapon System
CTEA	Cost and Training Effectiveness Analysis

D

D&V	Demonstration and Validation
DA	Department of the Army
DCD	Directorate of Combat Developments
DCS	Deputy Chief of Staff
DDI	Design Difference Index

DEP	Draft Equipment Publication
DMDC	Defense Manpower Data Center
DoD	Department of Defense
DOTD	Directorate of Training and Doctrine
DPAMMH	Direct Productive Annual Maintenance Man-Hours
DS	Direct Support Maintenance
DSARC	Defense System Acquisition Review Council
DSWS	Division Support Weapon System
DT/OT	Developmental Testing/Operational Testing
DTIC	Defense Technical Information Center

E

EIC	Equipment Identification Code
E-O	Electro-optical
EPMS	Enlisted Personnel Management System
ETM	Extension Training Materials
EW	Electronic Warfare

F

FEA	Front-End Analysis
FGC	Functional Group Code
FLIR	Forward-Looking Infrared Radar
FM	Field Manual
FRE	Frequency

FSD	Federal Supply Document
FSED	Full-Scale Engineering Development

G

GFE	Government-Furnished Equipment
GP	Group-Paced

H

HARDMAN	Hardware vs. Manpower
HCM	HARDMAN Comparability Methodology
HIP	Howitzer Improvement Program
HIPO	Hierarchical and Input/Process/Output Techniques
HMPT	Human Factors, Manpower, Personnel, and Training

I

I/S	Instructor-to-Student Ratio
ICH	Instructor Contact Hours
ICTP	Individual and Collective Training Plan
IEP	Independent Evaluation Plan
IET	Initial Entry Training
IFF	Identification, Friend or Foe
IKP	Instructor and Key Personnel
ILS	Integrated Logistic Support
IOC	Initial Operational Capability
IPR	In-Progress Review

IPT	Indirect Productive Time
ISD	Instructional Systems Development
J	
JPL	Jet Propulsion Laboratory
JMSNS	Justification for Major System New Start
L	
LCC	Life Cycle Costs
LCN	LSA Control Number
LIN	Line Item Number
LCSMM	Life Cycle System Management Model
LOA	Letter of Agreement
LOGCEN	Logistics Center
LOGSACS	Logistics Structure and Composition System
LRU	Lowest Replaceable Unit
LSA	Logistic Support Analysis
LSAR	Logistic Support Analysis Record
LSI/VLSI	Large or Very Large Scale Integrated Circuits
M	
MAA	Mission Area Analysis
MAC	Maintenance Action/Allocation Chart
MAP	Materiel Acquisition Process
MARC	Manpower Requirements Criteria

MCO	Marine Corps Order
MEEI	Minimum Essential Elements of Information
MFP	Materiel Fielding Plan
MIL-STD	Military Standard
MILPERCEN	Military Personnel Center
MMH	Maintenance Man-hours
MMH/MA	Maintenance Man-hours Per Maintenance Action
MOS	Military Occupational Specialty
MOSB	MOS Training Cost Handbook
MOSC	Military Occupational Specialty Code
MP/OMS	Mission Profile/Operational Mode Summary
MPA	Military Personnel, Army
MPT	Manpower, Personnel, and Training
MR	Maintenance Ratio
MRC	Maintenance Requirement Cards
MRSA	Materiel Readiness Support Activity
MTBF/MTBMA	Mean Time Between Failure/Mean Time Between Maintenance Action
MTTR	Mean Time to Repair
MTTR/MA	Mean Time to Repair Per Maintenance Action

N

NASA	National Aeronautics and Space Administration
------	---

NATO	North Atlantic Treaty Organization
NAVMACLANT	Navy Manpower and Materiel Analysis Center, Atlantic
NAVEDTRA	Naval Education and Training
NAVPERS	Naval Personnel
Navy 3M	Materiel Maintenance Management
NBC	Nuclear, Bacteriological, Chemical
NCOES	Noncommissioned Officer Educational System
NEC	Naval Enlisted Classification
NEPDIS	Navy Enlisted Professional Development Information System
NET	New Equipment Training
NETP	New Equipment Training Plan
NITRAS	Navy Integrated Training Resources and Administration System
NMSO	Navy Maintenance Support Office
NODAC	Navy Occupational Development and Analysis Center
NOTAP	Navy Occupational Task Analysis Program
NTEC	Naval Training Equipment Center
NTP	Navy Training Plans
O	
O&O	Organizational and Operational Plan
OCS	Optimal Class Size
OM	Operational Manning

OMA	Operations and Maintenance, Army
ORSA	Operations Research/Systems Analyst
OSUT	One Station Unit Training
OT	Operational Test

P

Pam	Pamphlet
PERT	Program Evaluation Review Technique
PGD	Paygrade
PIB	Program Information Brief
PLDC	Primary Leadership Development Course
POE	Projected Operational Environment
POMCUS	Prepositioned Materiel Configured to Unit Sets
PM	Preventive Maintenance
PM	AMC Program/Project/Product Manager
PM TRADE	Project Manager for Training Devices
PNCOC	Primary Noncommissioned Officer Course
POE	Projected Operational Environment
POI	Program of Instruction
PQS	Position Qualification Standards
PTC	Primary Technical Course
PV	Perturbation Value

Q

QQPRI Quantitative and Qualitative Personnel Requirements Information
Quasi-POI Quasi-Program of Instruction

R

R&M Reliability and Maintainability
RAM Reliability, Availability, and Maintainability
Reg Regulation
ROC Required Operational Capability
RPV Remotely Piloted Vehicle

S

SAT Systems Approach to Training
SDC Sample Data Collection
SEAD Suppression of Enemy Air Defense
SGMA Sergeants Major Academy
SINGARS Single Channel Ground/Airborne Radio System
SME Subject-Matter Expert
SOJT Supervised On-the-Job Training
SP Self Paced
SPH Self-Propelled Howitzer
SPT Support
SQT Skill Qualification Test
SSC Soldier Support Center

SSG	Special Study Group
SSI	Specialty Skill Identifier
SSPO	Strategic Systems Project Office
STP	Soldier Training Publication
SUBLANT	Submarines Atlantic
SUBPAC	Submarines Pacific

T

TAMMS	The Army Maintenance Management System
TASC	Training and Audiovisual Support Center
TASO	Training Aids Support Office
TB	Technical Bulletin
TCA	Task Comparability Analysis
TD	Training Developer
TDIS	Training Development Information System
TDLR	Training Device Letter Requirement
TDR	Training Device Requirement
TEA	Training Effectiveness Analysis
TFR	Trouble Failure Reports
TLR	Top Level Requirements
TM	Technical Manual
TOE	Table of Organization and Equipment
TQOPRI	Tentative Qualitative and Quantitative Personnel Requirements Information

TRADOC	Training and Doctrine Command
TRAMEA	TRADOC Management Engineering Activity
TRAS	Training Requirements Analysis System
TTHS	Transients, Trainees, Holdees, and Students
TRRA	Training Resource Requirements Analysis
TSM	TRADOC Systems Manager

U

UHF	Ultra-High Frequency
USAMARDA	US Army Manpower Requirements and Documentation Agency

V

VHF-FM	Very High Frequency/Frequency Modulated
--------	---

W

WBS	Work Breakdown Structure
WQEC	Weapons Quality Engineering Center
WUC	Work Unit Code
WSAP	Weapons System Acquisition Process

Index

Volume I

Analysis scope, 3-13
Annual costs, 2-15
#Annual man-day requirements, 2-6
Audit trail, 2-1, 3-43, 3-67
Availability ratio, 2-21

Baseline Comparison System, 1-6, 1-35
Bill payer, 2-21, 3-64

Comparability analysis, 1-5, 1-34
Cost and training effectiveness,
2-15, 2-33
Critical resources, 2-24, 3-65

Data management structure, 3-39
Data source index, 3-37
Design freedom, 1-18

End-strength, 2-19

Footprint, 3-61
Functional Group Code, 3-41

High driver, 2-15, 2-19, 3-66

ICTP, 2-28
Impact analysis, 2-15
Instructional systems
development, 1-22
Intelligence, 1-15

Life Cycle System
Management Model, 2-33, 3-52
Level of indenture, 3-13
Logistic Support Analysis, 2-25

Mission Area Analysis, 1-30
MOSC, 3-41

Predecessor System, 1-30
Proposed System, 1-6, 1-34, 1-36

QQPRI, 2-29

Quasi-POI, 1-22

Risk, 1-13, 3-52

Scope, 3-1, 3-13

System, 3-5

Systems analysis, 1-12

Time, 1-16

Uncertainty, 1-13, 3-52

Volume II - IV

Baseline Comparison System, 1-1, 1C-2, 1C-25
Bill payer, 5-10
Comparability Analysis, 1-6
Corrective maintenance, 1D-9
Critical resources, 5-17

Design difference index, 1C-53

Equipment comparability
analysis, 1C-1
Equipment identification code, 1C-5

Footprint, 1C-22, 2-2
Function, 1B-5, 1B-8
Functional Group Code, 1C-6, 1C-14
Functional requirement, 1B-4

Generic tasks, 1-5, 1E-1, 1E-5

High driver, 5-1, 5-19

LCSMM, 1A-1, 1C-1
Level of indenture, 2B-10
LSAR, 1C-61

Maintainability, 1D-1, 1D-5
Maintenance, induced, 1D-1, 1D-9
Maintenance, inherent, 1D-1, 1D-9
Maintenance, preventive, 1D-9
Mean time to repair, 1D-7, 1D-8
Mission, 1A-1
Mission area, 1A-1, 1A-5
Mission Area Analysis, 1A-5, 1B-1
Mission event, 1A-19

Perturbation, 1C-55, 1C-61
Performance measure, 1B-13, 1B-15
Performance standard, 1B-13, 1B-15
Predecessor System, 1-1, 1C-1, 1C-19
Proponent, 1A-2, 1A-7
Proposed System, 1-1, 1C-35, 1C-41

Reliability, 1D-1, 1D-5
Risk, 5-17

Sample Data Collection, 1D-12
Sub-function, 1B-8, 1B-9
System, 1A-1
System functional requirement,
1A-13, 1B-5
Systems analysis, 1-1

Task, 1E-1, 1E-5
Task, Maintainer, 2B-10
Task, Operator, 2B-8
Tradeoff Analysis, 6-1