

AD-R157 111

ENVIRONMENTAL EFFECTS ON THE TENSILE STRENGTH OF
CHEMICALLY VAPOR DEPOSIT (CVD) NATIONAL AERONAUTICS AND
SPACE ADMINISTRATION CLEVELAND OH LE...

1/1

UNCLASSIFIED

B T BHATT ET AL. APR 85 NASA-E-2519

F/G 20/12

NL

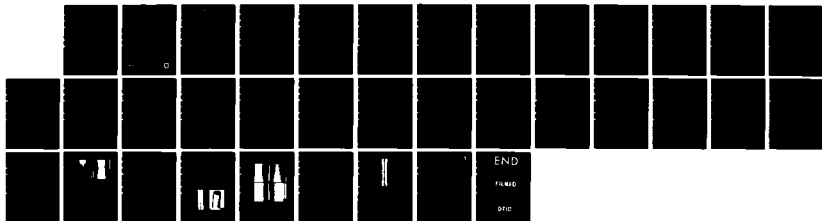

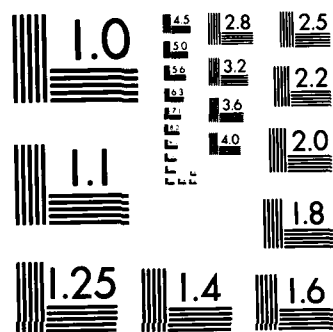

MICROCOPY RESOLUTION TEST CHART
NBS-1963-A

2

NASA
Technical Memorandum 86981

USAAVSCOM
Technical Report 85-C-4

Environmental Effects on the Tensile Strength of Chemically Vapor Deposited Silicon Carbide Fibers

AD-A157 111

R.T. Bhatt
Propulsion Laboratory
AVSCOM Research and Technology Laboratories
*Lewis Research Center
Cleveland, Ohio*

and

M.D. Kraitchman
*Lewis Research Center
Cleveland, Ohio*

This document has been approved
for public release and its
distribution is unlimited.

April 1985

DTIC FILE COPY

NASA

DTIC
ELECTE
JUL 31 1985



85 7 17 008

1. Report No. NASA TM-86981 USAAVSCOM-TR-85-C-4		2. Government Accession No. AD-A157 111		3. Recipient's Catalog No.	
4. Title and Subtitle Environmental Effects on the Tensile Strength of Chemically Vapor Deposited Silicon Carbide Fibers				5. Report Date April 1985	
				6. Performing Organization Code 533-05-12	
7. Author(s) R.T. Bhatt and M.D. Kraitchman				8. Performing Organization Report No. E-2519	
				10. Work Unit No.	
9. Performing Organization Name and Address NASA Lewis Research Center and Propulsion Laboratory U.S. Army Research and Technology Laboratories (AVSCOM) Cleveland, Ohio 44135				11. Contract or Grant No.	
				13. Type of Report and Period Covered Technical Memorandum	
12. Sponsoring Agency Name and Address National Aeronautics and Space Administration Washington, D.C. 20546 and U.S. Army Aviation Systems Command, St. Louis, Mo. 63120				14. Sponsoring Agency Code	
15. Supplementary Notes R.T. Bhatt, Propulsion Laboratory, AVSCOM Research and Technology Laboratories, Lewis Research Center, Cleveland, Ohio 44135; M.D. Kraitchman, NASA Lewis Research Center. Material previously presented at the 8th Annual Conference on Composites and Advanced Ceramic Materials sponsored by the American Ceramic Society, Cocoa Beach, Florida, January 15-20, 1984.					
16. Abstract The room temperature and elevated temperature tensile strengths of commercially available chemically vapor-deposited (CVD) silicon carbide fibers were measured after 15 min heat treatment to 1600 °C in various environments. These environments included oxygen, air, argon and nitrogen at one atmosphere and vacuum at 10 ⁻⁹ atmosphere. Two types of fibers were examined which differed in the SiC content of their carbon-rich coatings. Threshold temperature for fiber strength degradation was observed to be dependent on the as-received fiber-flaw structure, on the environment and on the coating. Fractographic analyses and flexural strength measurements indicate that tensile strength losses were caused by surface degradation. Oxidation of the surface coating is suggested as one possible degradation mechanism. In general, the SiC fibers containing the higher percentage of SiC near the surface of the carbon-rich coating showed better strength retention and higher elevated temperature strength.					
17. Key Words (Suggested by Author(s)) Silicon carbide fibers Strength measurement Environmental degradation			18. Distribution Statement Unclassified - unlimited STAR Category 27		
19. Security Classif. (of this report) Unclassified		20. Security Classif. (of this page) Unclassified		21. No. of pages	22. Price*

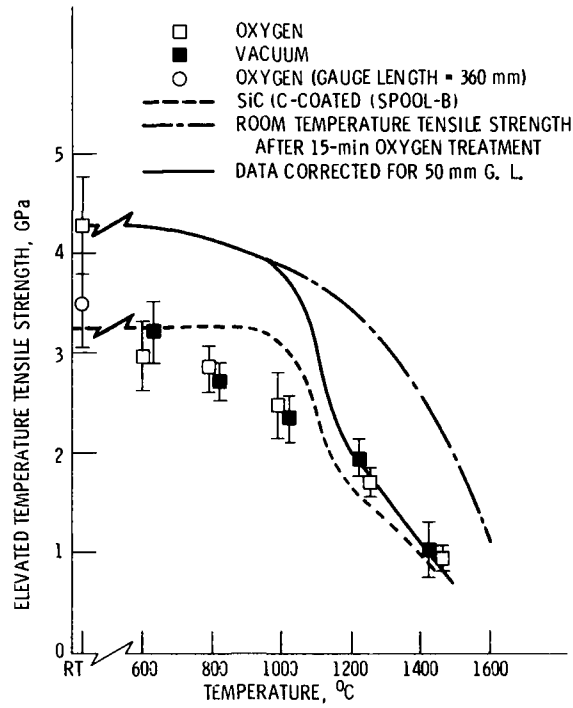

Figure 14. - Elevated temperature tensile strength of SC S-6 fibers after 15 min exposure to various environments at indicated temperatures.

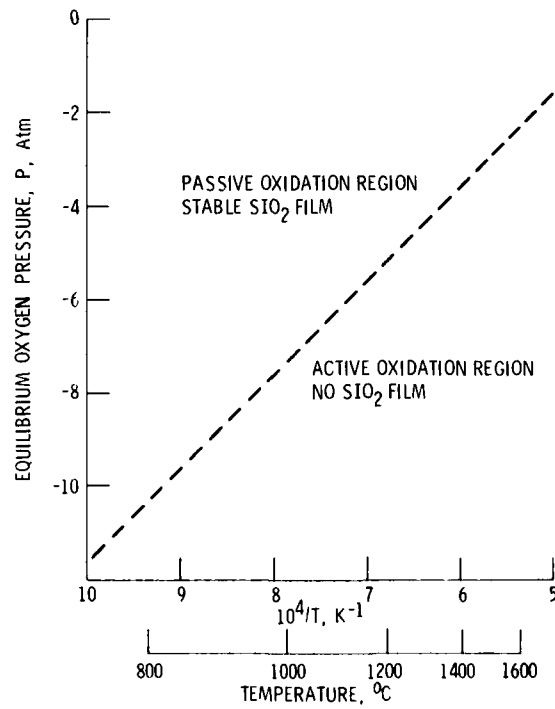

Figure 15. - Equilibrium oxygen partial pressures for passive and active oxidation of SiC (from Gulbransen and Jansson, Ref. 12).

①

**ENVIRONMENTAL EFFECTS ON THE TENSILE STRENGTH
OF CHEMICALLY VAPOR DEPOSITED SILICON CARBIDE FIBERS***

R.T. Bhatt
Propulsion Laboratory
AVSCOM Research and Technology Laboratories
Lewis Research Center
Cleveland, Ohio 44135

and

M.D. Kraitchman
National Aeronautics and Space Administration
Lewis Research Center
Cleveland, Ohio 44135

Approved For	
GRA&I	<input checked="" type="checkbox"/>
TAB	<input type="checkbox"/>
Announced	<input type="checkbox"/>
Classification	<input type="checkbox"/>
By	
Distribution/	
Availability Codes	
Avail and/or	
Dist	Special
A-1	

ABSTRACT

The room temperature and elevated temperature tensile strengths of commercially available chemically vapor-deposited (CVD) silicon carbide fibers were measured after 15 min heat treatment to 1600 °C in various environments. These environments included oxygen, air, argon and nitrogen at one atmosphere and vacuum at 10⁻⁵ atmosphere. *5. The minimum 9th power* Two types of fibers were examined which differed in the SiC content of their carbon-rich coatings. Threshold temperature for fiber strength degradation was observed to be dependent on the as-received fiber-flaw structure, on the environment and on the coating. Fractographic analyses and flexural strength measurements indicate that tensile strength losses were caused by surface degradation. Oxidation of the surface coating is suggested as one possible degradation mechanism. In general, the SiC fibers containing the higher percentage of SiC near the surface of the carbon rich coating showed better strength retention and higher elevated temperature strength.

E-2519

*Material previously presented at the 8th Annual Conference on Composites and Advanced Ceramic Materials sponsored by the American Ceramic Society, Cocoa Beach, Florida, January 15-20, 1984.

1. INTRODUCTION

High modulus, high strength chemically vapor deposited (CVD) SiC fibers are a potential reinforcement candidate for ceramic matrix composites (CMC) with envisioned service at elevated temperatures. However, the high temperature fabrication and use of such composites may expose these fibers to reactive gaseous environments which can subsequently lead to degradation in their strength properties. This study was performed to evaluate these effects for commercially available CVD SiC fibers. The fibers were heated in oxygen, air, nitrogen, argon, and vacuum environments for 15 min at temperatures to 1600 °C and then tensile tested at temperature or at room temperature. Any surface degradation occurring after thermal exposure was observed by optical and scanning electron microscopy. Whenever possible, the fiber fracture surfaces were studied to determine the fracture origin. In some cases, flexural strength tests were also performed to aid in establishing surface degradation of the fibers.

2. EXPERIMENTAL

2.1 Specimens

The SiC fibers used in this study were obtained from AVCO Specialty Materials Division. The fibers were produced by chemical vapor deposition (CVD) from methyltrichlorosilane onto a 37 μm (1.3 mil) heated carbon monofilament which was pulled continuously through the deposition reactor (Ref. 1). Different coatings were deposited onto the SiC fiber by introducing hydrocarbon gases or a mixture of hydrocarbon gas and silane vapor near the exit port of the reactor. A schematic of the fiber cross-section is shown in Fig. 1(a). The fiber consists of a SiC sheath with an outer diameter of 142 μm surrounding a pyrolytic graphite coated carbon core with an outer diameter of 37 μm . The SiC sheath is entirely comprised of columnar β -SiC

grains growing in a radial direction with $\langle 111 \rangle$ preferred orientation (Ref. 1). The grain size varies considerably within the sheath and ranges from 40 to 100 μm (Ref. 1).

In this study, SiC fibers with two types of coatings were investigated. The first type of coating was developed in early 1970 by AVCO and contained a carbon-rich coating which served to blunt the effect of intrinsic surface flaws and also to improve the abrasion resistance of the fibers. The carbon coating is graded in composition from pure carbon at the outside surface to nearly stoichiometric SiC at a depth of $\sim 1 \mu\text{m}$ (Ref. 1). A typical representation of the variation of the silicon/carbon ratio in the carbon-rich coating is shown in Fig. 1(b).

The second type of coating on the SiC fiber, which was developed by AVCO for metal matrix composites, contained an overlayer with high silicon/carbon ratio on top of an amorphous carbon layer (as shown in Fig. 1(c)). The total thickness of the coating is $\sim 2 \mu\text{m}$. This type, referred to henceforth as SCS-6, improved bonding and wettability of the fiber and reduced reactivity of the fiber in many metallic matrices. Recently Wawner et al. (Ref. 1), using transmission electron microscopy, have identified three distinct layers in the coating. The outermost layer consists of a mixture of amorphous carbon and randomly oriented SiC grains. The second layer beneath the outermost is essentially an amorphous carbon. The third and innermost layer is made up of a mixture of α and β SiC.

In this study, specimens from three spools of silicon carbide fibers were used. Two spools, A and B, contained SiC fibers with only the carbon coating (cf. Fig. 1(b)). Fibers from these spools differed markedly in as-received tensile strength; averaging 5.4 GPa for spool A and 3.2 GPa for spool B. The other spool contained SCS-6 fibers with an average room temperature strength in the as-received condition of 4.3 GPa.

2.2 High Temperature Test Apparatus

The apparatus used to heat and tensile test the fibers at high temperature in a gaseous environment is shown schematically in Fig. 2. It is similar to that employed by other investigators (Refs. 2 to 5) for high temperature tensile strength and for creep deformation studies. The apparatus consists essentially of a 95 mm long, 25 mm o.d. pyrex tube with stainless steel end caps. The caps contained entry and exit ports for the environmental gases, and mercury reservoirs to provide electrical contact to the fiber which was resistance heated to temperature by a dc power supply. The fiber temperature was measured with an optical pyrometer with an accuracy of ± 10 °C. The recorded temperatures were corrected for the glass absorption and for the emissivity of the fiber surfaces (Ref. 5).

For thermal exposure studies, a 230 mm length of fiber was inserted in the environmental chamber and secured at the top with a clamp. The lower end of the fiber which extended from the lower cap was provided with a small weight to prevent any bowing of the fiber inside the reactor during heating. Environmental gases were flowed continuously at one atmosphere through the chamber at 500 cc/min before, during, and after heating. Environmental gases used were of commercial purity, and the estimated oxygen content of the flowing argon and nitrogen gases was 100 ppm. The fiber was resistance heated for 15 min at temperature. In all cases, only 50 mm of the fiber length was in the hot zone.

After removal from the chamber, the fibers were prepared for room temperature tensile testing by forming aluminum foil clamps at each end of the fiber, leaving the 50 mm heated zone as the gauge length. The aluminum foils were then inserted in pneumatic grips and the fiber specimens were pulled to

failure using an Instron at a constant cross head speed of 1.3 mm/min. For each thermal treatment, the tensile strengths of 10 to 20 specimens were measured.

For elevated temperature strength measurements, the environmental chamber was mounted between the top and the bottom grips of the Instron machine. The fiber ends were again clamped between aluminum foils as before. The lower foil clamp was not inserted in the pneumatic grip until the fiber reached the test temperature. The mercury seals provided negligible restraint to the deformation of the fiber during testing. For these tests, the total length of the fiber used was 360 mm but only 50 mm length was heated. The fiber was pulled to failure at a cross head speed of 1.3 mm/min.

Elevated temperature strength measurements and heat treatments in vacuum were performed in an Instron machine fitted with a Brew^R vacuum chamber containing a 100 mm long tungsten mesh heating element. The top and bottom grips present within the environmental chamber were water cooled. As in the other method of testing, aluminum foils were clamped at each end of the fiber. The fibers were heated for 15 min at temperature and were pulled to failure at a constant cross head speed of 1.3 mm/min. and the load to failure was recorded. For these elevated temperature tests, the total length of the fiber used was 360 mm, but only 50 mm was in the constant temperature heated zone. The vacuum in the furnace was maintained at about 10^{-9} atm. The temperature of the fiber was determined from a thermocouple placed close to the fiber. For room temperature tests, a 130 mm length of fiber was cut from the central section of the fibers heated in vacuum. The fiber was then tensile tested as described above.

Flexural strength measurements were performed by bending fibers around a cone-shaped brass mandrel. From base to apex, the cone diameter D decreased in discrete steps of $\Delta(D) = 0.76$ mm. Starting at the largest diameter step,

each fiber was bent uniformly around the cone to a semicircle of length πD . If fracture did not occur, the fiber was raised to the next smaller diameter step and the bending process repeated until fracture occurred. The flexural strength, σ_F , was calculated from the equation,

$$\sigma_F = \frac{ED}{d}$$

where E is the fiber modulus, d is the fiber diameter, and D is the smallest cone diameter at which the fiber fractured. For measurement of flexural strength, the values of $E = 425$ GPa and $d = 0.142$ mm were used.

3.0. RESULTS

3.1. Strength After Thermal Exposure

3.1.1. SiC (C-coated) fibers. - As previously mentioned, the room temperature average tensile strengths of untreated spool A and spool B fibers were markedly different. Because the production years for each spool were different, this strength difference is attributed to changes in the manufacturing procedure. Furthermore, these fibers also showed significant differences in their surface microstructures. A representative photomicrograph of the fiber surfaces, shown in Fig. 3, reveals finer grains and a smoother surface in the high strength spool A fibers, and a larger corn cob structure and coarser surface in the low strength spool B fibers. Due to the explosive nature of fiber fracture at these high strength levels, original fracture surfaces could not be retained for analysis of the strength-controlling flaws in the as-received fibers.

The room temperature tensile strengths of spool A and spool B fibers after heat treatment in a one atmosphere oxygen environment for 15 min at temperatures to 1600 °C are shown in Fig. 4. In this figure as well as following figures, the data points and error bars show the average and standard deviation, respectively. Also shown in the figure are the room temperature average

tensile strengths for as-received fibers against which the thermal exposure data can be compared to determine any strength loss. Figure 4 indicates that up to 600 °C, spool A fibers showed no significant loss in strength. As the temperature of exposure increased, however, strength decreased rapidly but then reached an approximately constant value of 3.0 GPa from 1000 to 1200 °C. On the other hand, spool B fibers heated to 1200 °C showed no significant loss in strength from the as-received strength value of 3.2 GPa. Above 1200 °C, the strength of both spools A and B decreased continuously and in a similar manner with increasing temperature.

The room temperature tensile strengths for spools A and B after heat treatment in argon, nitrogen, and vacuum environments for 15 min at temperatures up to 1600 °C are shown in Fig. 5. Also shown for comparison purposes are the room temperature strength data of Ahmed et al. (Ref. 3) at 50 mm gauge length for similar carbon-coated SiC fibers heated in a helium environment for 5 min. From Fig. 5, it can be seen that spool A fibers heated to 800 °C showed no appreciable loss in strength from the as-received state. This is an improvement of nearly 200 °C when compared with the strength data of the same fiber heated in oxygen (Fig. 4). Above 800 °C, however, a continuous loss in fiber strength was observed with increasing temperature independent of the environment. In contrast, spool B fibers heated to 1000 °C showed minimal strength loss from their as-received state. However, at temperatures above 1000 °C, a loss in strength similar to spool A was observed. For both spools, at temperatures above 1400 °C, fibers heated in vacuum showed slightly less strength degradation than those heated in argon or in nitrogen environments. The strength data of Ahmed et al. (Ref. 3) on fibers heated in a helium environment agreed qualitatively with the argon/nitrogen strength data of spool B up to 1000 °C and with spools A and B up to 1400 °C. However, above 1400 °C,

whereas spool A and B fibers continued to lose strength, the fiber strength measured by Ahmed et al. (Ref. 3) reached a constant value near 1.4 GPa.

The tensile strength behavior of spool A and spool B fibers could be influenced by several possible factors including size of as-produced flaws, reaction between SiC sheath and carbon core, intrinsic weakening of SiC sheath, and surface degradation which can be either thermally or environmentally induced. By identifying the location of the microstructural flaws which caused fracture, one should be able to distinguish whether strength loss is brought about by surface degradation or by other internal effects.

For fibers treated to 1200 °C, direct observation of strength-controlling flaws was lacking because of the explosive nature of fiber fracture. Nevertheless, some insight on flaw location was obtained from the results of flexural strength tests which were primarily sensitive to surface flaws. The flexural strengths of spool A and spool B fibers heated in oxygen to 1200 °C are shown in Fig. 6. For comparison purposes, the figure also includes the flexural strengths of as-received, untreated fibers. The large difference in the flexural strength of spool A and spool B fibers in the as-received condition can be attributed to differences in their surface microstructure (Fig. 3). That is, past studies (Refs. 6 and 7) have clearly demonstrated that the flexural strength of fiber can be modified by smoothing the fiber surface. It is therefore suggested that the high flexural strength of spool A is associated with smaller surface flaws and smoother surface; whereas the comparatively lower flexural strength of spool B is due to larger surface flaws and coarser surface. As the fibers were heated in oxygen, above 500 °C their flexural strength decreased continuously at least up to 1000 °C. Then between 1000 to 1200 °C, no further loss in flexural strength was observed. Because surface or subsurface flaws primarily control flexural strength, the loss in flexural strength to 1000 °C was probably caused by surface degradation.

The fibers heated in oxygen above 800 °C were observed to have an outer silica layer. To determine if the silica layer influenced the strength results, fibers in the as-received condition and fibers heated in oxygen between 800 to 1200 °C for 15 min were etched in 40 percent Hf + 40 percent HNO₃ + 20 percent H₂O solution for 2 hr in order to remove surface silica. The flexural strength data of etched and unetched fibers shown in Table I indicate a loss of ~1.75 GPa in the flexural strength of etched fibers when compared with similar fibers in an unetched condition. For as-received fibers, however, acid treatment did not cause any appreciable loss in their flexural strength. Thus the Fig. 6 data above 800 °C appear to be influenced in a beneficial manner by the surface silica.

Flexural strengths of spool A and spool B fibers heated in a vacuum environment to 1600 °C are shown in Fig. 7. The spool A fibers heated to 800 °C showed relatively no loss in flexural strength from the as-received condition. With increasing temperature of exposure, however, strength decreased continuously. Whereas in spool B, fiber strength loss was observed only after 1000 °C. Moreover, both fibers heated beyond 1000 °C showed similar strength values. Again, loss in the flexural strength indicates surface degradation. Thus measurements of flexural strength have shown that surface degradation occurs in carbon coated SiC fibers heated either in oxygen or in a vacuum environment. As will be discussed, the major mechanism for both effects is probably related to a degradation of the surface flaw-healing capability of the carbon coating.

Further insight into the strength degradation of spool A and spool B fibers heated in different environments up to 1000 °C comes from comparison of the tensile and the flexural strength results shown earlier in Figs. 4 to 7. It is obvious from this comparison that while the tensile strengths of spool A and spool B fibers heated in oxygen to 600 °C showed no significant loss from

TABLE I. - FLEXURAL STRENGTH OF SiC FIBERS (SPOOL B)

Condition of the Fibers	Flexural Strength GN/m ²	
	Before etching	After etching
As received	5.86 ± 0.62 ^a	5.98 ± 0.70
Heated ^b in O ₂ at 800 °C	4.05 ± 0.29	2.14 ± 0.12
Heated ^b in O ₂ at 1000 °C	3.32 ± 0.27	2.25 ± 0.10
Heated ^b in O ₂ at 1200 °C	3.60 ± 0.24	1.82 ± 0.06

^aStandard deviation for 20 individual SiC fibers.

^bFibers heated for 15 min.

8. McHenry, K.D.; and Tressler, R.E.: Elevated Temperature Strength of Silicon Carbide-on-Carbon Filaments. *J. Comp. Mat.*, vol. 9, no. 1, Jan. 1975, pp. 73-76.
9. DiCarlo, J.A.; Wagner, T.C.; and Bhatt, R.T.: Oxidation Effects on Carbon Coated CVD SiC Fibers. (to be published in *Ceram, Eng. Sci. Proc.*).
10. Harris, Richard Charles A.; and Call, R.L.: Oxidation of 6H Alpha Silicon Carbide. *Silicon Carbide*, R.C. Marshall, J.W. Faust, Jr. and C.E. Ryan eds., University of South Carolina Press, 1974, pp. 329-336.
11. Fitzer, E.; and Ebl, R.: Kinetic Studies on the Oxidation of Silicon Carbide. pp. 320-328.
12. Gulbransen, Earl A.; and Jansson, Sien A.: The High-Temperature Oxidation, Reduction, and Volatilization Reactions of Silicon and Silicon Carbide. *Oxid. Met.*, vol. 4, no. 3, Sept. 1972, pp. 181-201.
13. Bhatt, R.T.: Surface Analysis of CVD SiC Fibers. (to be published in *J. Mater. Sci.*)

4. In general, C-coated SiC fibers heated above 800 °C in various environments and then tensile tested at temperature or at room temperature showed greater strength degradation than SiC/C coated SiC fibers tested under similar conditions.

5. An important point to note is that strength loss increased with increasing exposure temperature.

REFERENCES

1. Wawner, F.W.; Teng, A.Y.; and Nutt, S.R.: Microstructural Characterization of SiC (SCS) Filaments. SAMPE Q., vol. 4, no. 3, Apr. 1983, pp. 39-45.
2. Ahmad, I., et. al: Reinforcement of Iron Chromium Aluminum Yttrium (FeCrAlY) with Silicon-Carbide (Carbon Core) Filament. Advanced Fibers and Composites for Elevated Temperatures, I. Ahmad and B.R. Noton, eds., AIME, New York, 1980, pp. 156-174.
3. Ahmad, I.; Hill, D.N.; and Heffernan, W.: Silicon Carbide Filaments as Reinforcements for High Temperature Alloy Matrices. ICCM, Proceedings of the 1975 International Conference on Composite Materials, vol. 1, E. Scala, et al, eds., AIME, New York, 1976, pp. 85-102.
4. DiCarlo, J.A.: Techniques for Increasing Boron Fiber Fracture Strain. NASA TM-X-73627, 1977.
5. DiCarlo, James A.: Creep of Chemically Vapor Deposited SiC Fibers. NASA TM-86897, 1984.
6. Wawner, F.E., Jr.: Effect of Chemical Polishing on the Strength and Fracture Characteristics of Amorphous B Filaments. Boron: Preparation, Properties, and Applications, Vol. 2, Gerhart K. Gaule, ed., Plenum, 1965, pp. 283-300.
7. Smith, Robert J.: Changes in Boron Fiber Strength Due to Surface Removal by Chemical Etching. NASA TN-D-8219, 1976.

required to understand the influence of various factors on elevated temperature strengths of SiC fibers.

5.0. CONCLUSIONS

The combined effects of thermal and environmental exposure on the room temperature tensile and flexural strengths and the elevated temperature tensile strengths of carbon coated and SiC/C coated SiC fibers have been evaluated.

The important findings are as follows:

1. Both carbon coated and SiC/C coated SiC fibers (SCS-6) heated above a certain threshold temperature in argon, nitrogen, oxygen or vacuum environment and then tensile tested at room temperature showed strength loss from their strength in the as-received condition. The threshold temperature for strength degradation depended on the relative sizes of the as-produced internal flaws and the treatment-induced surface flaws, the environment, and the surface coating structure. Flexural strength measurements and fractographic analyses showed that strength loss is caused primarily by surface degradation.

2. One possible mechanism for surface degradation is the oxidation of the surface coating. For example, the strength degradation occurring in oxygen below 1000 °C was probably caused by oxidation of the carbon coating for the SiC fibers. This effect was absent in the SCS-6 fibers at least for a 15-min treatment. Above 1000 °C, the strength loss mechanism is still uncertain. Apparently the fiber surface is degrading for both coating types as evidenced by the formation of pits which eventually control fiber strength.

3. Both types of fibers heated at elevated temperatures in various environments and then tensile tested at temperature showed significant loss in strength from their strengths in the as-received or heat treated condition. No significant effect of environment on elevated temperature tensile strength was noticed. The mechanism of strength degradation is not clear at present, however, creep deformation is probably one important factor.

dependent on the availability of oxygen in the environment, different strength levels were observed in fibers exposed to environments containing different amounts of oxygen.

In carbon coated SiC fibers, as the oxidation of the coating proceeds inwards, less and less amounts of gaseous products are formed due to the decreasing concentration of free carbon and the increasing the amount of SiO₂ being formed on the surface. This process favors a continuous film of SiO₂ which delays the diffusion of oxygen to the SiC substrate as well as heals the flaws formed due to the oxidation of carbon. It is for this latter reason that carbon coated SiC fibers heated in oxygen are stronger than those heated in argon or in vacuum. Whereas in SCS-6 fibers because of the presence of a free carbon layer beneath the outer SiO₂ layer as oxidation proceeds, greater amounts of gaseous products are produced which eventually breaks open the SiO₂ layer. This causes holes in the coating which are perhaps too large to be sealed by further oxidation. The SCS-6 fibers heated in oxygen are then weaker than those heated in argon or vacuum..

4.3. Tensile Strength at Elevated Temperatures

The understanding of the mechanism of elevated temperature strength degradation with increasing test temperature is complicated by several changes which can occur in the fiber at the test temperature. These include: (1) relief of residual stresses related to thermal expansion mismatches, (2) stress induced surface coating cracking and increased oxidation, and (3) time dependent deformation or creep. A recent creep deformation study (Ref. 5) has indicated significant inelastic deformation in these fibers when stressed at temperatures in excess of 1000 °C. It appears, therefore, that in addition to surface degradation intrinsic weakening of the fiber may also be occurring concurrently during high temperature testing. However, further study is

determined the values of O_2 partial pressure, P_{O_2} , below which active oxidation occurs and above which passive oxidation occurs. These values of P_{O_2} are shown in figure 15 as a function of temperature. According to this figure, at the 10^{-4} oxygen pressure (P_{O_2}) typically present in commercially available argon gas and at $P_{O_2} = 10^{-10}$ maintained in the vacuum environment, active oxidation of SiC may be seen at 1380 and 820 °C, respectively. Indication of diameter loss and severe pits on the surface of the fibers heated in argon above 1300° suggests strength degradation is caused by this mechanism.

4.2. SCS-6 Fiber Strength Degradation After Thermal Exposure

The mechanism of strength degradation of SCS-6 fibers heated in various environments and the significant difference between the strength loss behavior of SCS-6 and carbon coated SiC fibers can be explained by phenomena occurring on the fiber surface. The SCS-6 fibers are provided with a coating of SiC on the top of the carbon coating whereas the other type of fiber contains only a carbon coating. The composition and thickness of the coating on these fibers were discussed previously. If we consider only the concentration of free carbon present in the surface coating of SCS-6 fibers, it increases as we move inward from the surface, reaches a maximum value near the middle region and decreases in the innermost layer. In the presence of oxygen, therefore, initial oxidation of free carbon and SiC is most likely. The solid oxidation product, SiO_2 , would then cover the middle and innermost coating layers. As the oxygen diffuses through the SiO_2 , the gaseous products, $CO(g)$ or $CO_2(g)$, either accumulate at the SiO_2/SiC interface or escapes through the oxide layer. The increasing tendency for pit and pinhole formation and the greater strength degradation in fibers heated above 800 °C in an oxygen environment compared to those heated in vacuum or in argon environments indicate that gas pockets eventually escape through the SiO_2 thereby exposing the inner coating layers and the SiC fiber surface to local oxygen attack. The rate of oxidation being

and pits on the fiber surface is consistent with the stated mechanism (Fig. 8). However, it is not clear whether the bubbles are caused by the formation of CO gas from the oxidation of the SiC sheath or from the oxidation of excess carbon in the sheath (Ref. 13).

The strength degradation curves for SiC fibers heated in argon and vacuum were similar even though the argon and vacuum environments contained 10^{-4} and 10^{-10} atm of trace oxygen, respectively. At these trace levels of oxygen, the carbon coating should be stable above 800 °C. Extending the argument offered for the strength degradation of fibers heated in an oxygen environment to the fibers heated in argon and in a vacuum environment, the initial strength degradation may be partly associated with the oxidation of carbon. However, the degradation curves above 800 °C are similar even though the carbon removal rate should be significantly smaller in vacuum than in argon. This oxygen independent effect suggests that above 800 °C some other mechanism, such as SiC or carbon coating thermal instability, may be causing flaw formation on the fiber surface (Ref. 9). To what temperature and to what extent the oxidation of carbon or thermal instability effects will influence the strength of the fibers is not resolved. The greater strength degradation seen in fibers heated in argon and vacuum between 1100 to 1300 °C compared to those heated in oxygen possibly indicates that any SiO₂ layer formed is not effective in inhibiting the flaw formation on the fiber surface due to gaseous removal of material.

At high temperatures and in environments containing low partial pressure of oxygen such as argon, nitrogen or vacuum, SiC oxidation generally results in SiO gas and CO gas, and any SiO₂ present on the surface will dissociate into SiO gas and oxygen. Here all reaction products being gases, a linear oxidation rate is observed which is generally also linearly dependent on oxygen pressure. This type of oxidation is referred to as active because of a weight loss associated with SiC removal (Ref. 11). Gulbransen et al. (Ref. 12) have

relative flaw sizes of the treatment-induced surface and of the as-produced internal flaws.

In addition to the carbon coating, the SiC base fiber can also be oxidized especially at temperatures above 800 °C (Refs. 10 and 11). For high oxygen pressures, a solid film of SiO₂ forms on the SiC surface which prevents easy access of oxygen to the substrate for further oxidation. The gaseous product of oxidation, CO, either escapes by diffusing through the oxide layer or accumulates to form bubbles at the SiO₂/SiC interface. A parabolic time dependence of oxide thickness and weight gain is usually observed. This type of oxidation behavior is generally termed passive.

This oxidation model could also be used to explain the strength behavior of SiC fiber exposed to various environments. Above 800 °C in 1 atm oxygen, the free carbon is probably all removed leaving only the oxide layer which grows more rapidly with increasing temperature of exposure. From 900 °C to 1200 °C, the strength of the fibers seems to level off suggesting no new flaws are being created. One possible reason for strength stabilization is that the oxide film formed is sealing off the flaws. This model is supported by the chemical etching results. If it is assumed that the acid mixture used for etching did not cause any damage to the SiC substrate, then ~1.8 GPa loss in flexural strength after acid treatment could be associated with the removal of the SiO₂ layer and the exposure of low strength flaws. Thus a beneficial effect of the SiO₂ layer is seen.

Further strength loss seen in fibers heated in oxygen above 1200 °C could be due to instability created in the SiO₂ film by high internal pressure of CO gas at the SiO₂/SiC interface. In addition, the trace impurities present in the fiber react with the oxide layer to form a low melting glass. When the gas pressure is sufficiently high, it may deform and eventually break open the oxide layer thus promoting oxidation of substrate. The observation of bubbles

4.0. DISCUSSION

4.1. SiC (C-coated) Fiber Strength Degradation After Thermal Exposure

The SiC fibers used in this study (both spool A and spool B) were provided with a carbon rich coating primarily to blunt and seal off the surface flaws on the SiC base fiber and thereby increase their flexural and tensile strength. One probable and likely mechanism for the strength degradation is therefore removal of carbon and exposure of surface flaws on the base fiber. This can be accomplished by the oxidation of the surface coatings which can occur in one atmosphere oxygen above 400 °C (Ref. 9). The effect of carbon oxidation is best seen in the flexural strength data shown in Figs. 6 and 7. The spool A fibers heated in oxygen even at 600 °C, the lowest temperature heated, showed strength degradation, whereas for those heated in vacuum or in an argon environment, the threshold temperature for fiber degradation was increased up to 1000 °C.

Since the rate of removal of carbon and the exposure of surface flaws are closely related, the time and temperature required to expose flaws of the same size or to reach the same strength level in fibers should be dependent on oxygen partial pressure in the gas environment. Thus environments containing very low oxygen content should require longer exposure time or higher temperatures. Therefore, the greater threshold temperature for strength degradation for spool A fibers heated in a vacuum environment compared to those heated in an oxygen environment is attributed, in part, to a reduced availability of oxygen and to a lower oxidation rate of the carbon coating. Thus up to 1000 °C, SiC flexural strength degradation (cf. Figs. 6 and 7) can be explained by the oxidation of free carbon present in the coating. The delay in degradation seen in argon, nitrogen, and vacuum is a result of the low oxygen pressure in these environments. Whether surface degradation will influence the fiber tensile strength (cf. Figs. 4 and 5) depends on the

region and primary fracture surfaces could be retained. In most cases, optical examination of the primary fracture surfaces indicated surface flaws as the source of high temperature tensile fracture.

Figure 13 also indicates that at all test temperatures the elevated temperature tensile strengths of spool B fibers heated in a vacuum environment were similar to those treated in an oxygen environment and to the strength results of Ahmed et al. (Ref. 2) on fibers heated in helium. The strength results of Tressler (Ref. 8) on fibers heated in air were significantly higher than our strength results at least up to 800 °C. In general, no significant difference between the elevated temperature strengths of fibers heated in different environments was noticed.

3.2.2. SCS-6 (SiC/C-coated) fibers. - The elevated temperature strengths of SCS-6 fibers in vacuum and in oxygen environments after 15 min at temperatures to 1600 °C are shown in Fig. 14. The solid line again estimates the gauge length effect at lower temperatures. The elevated temperature strength loss curve for spool B fibers and the room temperature strengths of SCS-6 fiber after oxygen treatment at the same temperatures are also included in the figure for comparison purposes.

Figure 14 shows the elevated temperature strength of SCS-6 fibers decreased continuously with temperatures above 800 °C. Furthermore, no significant difference between strength loss behavior of SCS-6 fibers heated in vacuum and in oxygen was observed. At all test temperatures, SCS-6 fibers showed slightly better strength than carbon coated spool B fibers. Observation of primary fracture surfaces above 1100 °C also indicates that SCS-6 fiber fracture was surface initiated.

3.2. Elevated Temperature Strength

3.2.1. SiC (C-coated) fibers. - Elevated temperature tensile strengths of carbon coated SiC fibers (spool B) heated in oxygen and in vacuum for 15 min at temperatures to 1600 °C are shown in Fig. 13. Also shown in the figure for comparison purposes are the strength data of Tressler (Ref. 8) measured at 50 mm gauge length on similar fibers heated in air for 10 min and of Ahmed et al. (Ref. 2) measured at the same gauge length on fibers heated in helium for 2 min. The room temperature tensile strength data of spool B fibers after heat treatment in oxygen for 15 min are also shown as a reference against which the high temperature data can be compared.

According to Fig. 13, the elevated temperature strength of spool B fibers heated in oxygen at 600 °C was 0.8 GPa lower than the room temperature strength after treatment in oxygen at the same temperature. Between 600 to 800 °C, no significant change in elevated temperature strength was observed. Above 800 °C, however, strength decreased continuously with increasing temperature. At all test temperatures, the elevated temperature strengths of SiC fibers in an oxygen environment were generally lower than the room temperature strength of fibers heat treated in oxygen at the same temperature. Below 1000 °C, however, this may not be a valid conclusion. Because of the explosive nature of fiber fracture, some fibers in this temperature region may have fractured outside the 50 mm hot zone. In fact, the measurement of the room temperature tensile strength of untreated spool B fibers at 360 mm gauge length showed strength values of ~2.4 GPa which is similar to that obtained at 600 °C. This suggests that the initial strength loss below 1000 °C was probably a gauge length effect rather than an environmental or intrinsic weakening of the fibers. Thus the solid line was drawn in Fig. 13 to account for this effect and to represent more accurately the elevated temperature strength at 50 mm gauge length. Fiber tested above 1100 °C invariably failed within the heated

1000 °C, however, strength fell continuously with increasing temperature of exposure. At any temperature, fibers heated in argon showed slightly greater strength degradation than those in vacuum. In comparison, spool A fibers heated in similar environments showed strength loss after 800 °C, nearly 200 °C lower than the threshold temperature for strength degradation in SCS-6 fibers. Also, at all temperatures above 1000 °C, the spool A fibers showed lower strengths than the SCS-6 fibers even though they displayed higher strength at lower temperatures. Thus the high temperature advantage of the SiC/C coating on base SiC fibers is seen compared to the C coating alone.

Comparison of Figs. 10 and 11 shows that the strength loss behavior of the two fiber types varied considerably with environment. For example, the SCS-6 fibers heated in oxygen at temperatures exceeding 800 °C showed greater strength degradation than those heated in argon or in vacuum. In contrast, carbon coated SiC fibers heated in an oxygen environment between 1000 to 1600 °C showed better strength retention than those heated in argon or in vacuum.

To determine the cause of strength degradation in SCS-6 fibers, microstructural and fractographic analysis were conducted whenever possible. Examination of the surface of the fibers heated in oxygen at temperatures in excess of 800 °C showed silica, pits, and pinhole porosity (Fig. 12). The number of pits seen on the fiber surface increased with increasing temperature of exposure. At very high temperatures (>1300 °C), in addition to pits, bubbles were also seen on the fibers. In comparison, SCS-6 fibers heated in argon or in a vacuum environment showed only a few pits on the surface. In most cases, examination of the primary fracture surfaces of the broken fiber indicated that the surface flaws (pits, bubble,) are the source of fracture.

both argon and vacuum environments, gradual surface roughening was observed with increasing temperature of exposure. At temperatures above 1400 °C, subsurface pits and gradual thinning of the fiber were also noticed for the argon case. Representative micrographs of the fiber surface after treatment in argon at different temperatures are shown in Fig. 9. In most cases, examination of the primary fracture surfaces indicate surface flaw initiated failure.

3.1.2. SCS-6 (SiC/C-coated) fibers. - The room temperature tensile strengths of SCS-6 fibers heated in an oxygen environment for 15 min at temperatures up to 1600 °C are shown in Fig. 10. Included in the figure are the room temperature tensile strengths of SCS-6 fibers in the as-received condition. Also shown is the best fit strength loss curve for spool A fibers. The spool A fibers were chosen for comparison with SCS-6 fibers because they showed similar surface structure.

According to Fig. 10, heating SCS-6 fibers in oxygen up to 800 °C did not cause any significant strength loss from the as-received strength of 4.3 GPa. Above 800 °C, continuous loss in strength was observed with increasing exposure temperature. Comparison of the strength data of SCS-6 and spool A fibers shows that initially up to 700 °C the SCS-6 fibers are generally weaker than the spool A fibers. However above 800 °C, the SCS-6 fibers are stronger, indicating a high temperature advantage for the SiC/C coating over the C coating in an oxygen environment.

The strength results for SCS-6 fibers heated in argon, nitrogen and vacuum environments for 15 min at temperatures to 1600 °C are shown in Fig. 11. Again for comparison purposes, the strength loss behavior of spool A fibers heated in similar environments are also shown in the figure. It is evident that SCS-6 fibers heated in argon, nitrogen and vacuum environments at temperatures to 1000 °C showed no significant loss from their as-received strength. Above

their respective strengths in the as-produced condition, their flexural strengths decreased continuously. This indicates that surface flaws were formed but they were not large enough to control the tensile strength. Obviously, as-produced internal flaws which were much larger than the size of the surface flaws were controlling tensile strength at the lower temperature. The nature of these as-produced internal flaws is not certain, but they may be related to flaws at the core sheath interface.

The similar loss in both tensile and flexural strength of spool A fibers heated between 600 to 1000 °C suggests that heat treatment-induced surface degradation was now controlling tensile behavior for these fibers. In contrast, spool B fibers heated in the same temperature range showed continuous loss in flexural strength while their tensile strength remained relatively unchanged. Here again, it can be concluded that spool B tensile strength is controlled by as-produced internal flaws and the flexural strength by treatment-induced surface flaws. At temperatures above 1200 °C, both spools heated in the same environment showed similar tensile and flexural strength behavior. Therefore, it would appear that in this region the same treatment-induced surface flaws were controlling the tensile strength loss behavior of both spool A and spool B fibers.

Examination of fibers heated in different environments revealed increased surface roughening with increasing temperature. However, the surface roughening seen in different environments differed considerably. As previously mentioned, in an oxygen environment an oxide layer was found to grow on the surface of the fiber with increasing temperature of exposure. At high temperature, especially above 1400 °C, bubbles and pits were formed in the oxide film. These pits and surface flaws, shown in Fig. 8, were identified as a source of tensile fracture above 1400 °C. In this case, the fiber strengths were low enough for retention and analysis of original fracture surfaces. In

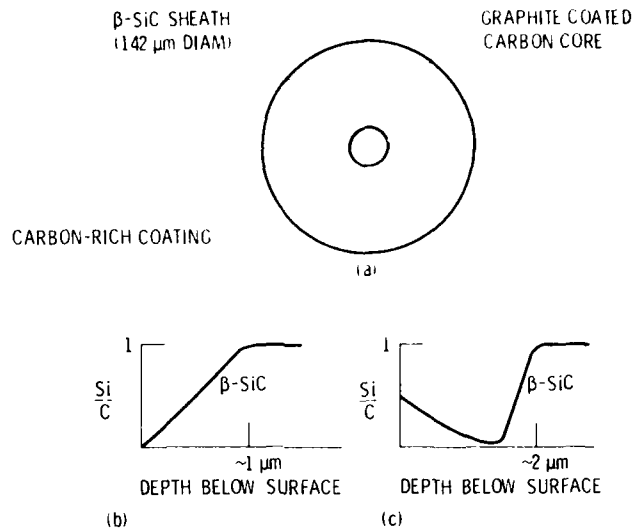

Figure 1. - (a) Schematic diagram of cross-section of coated AVCO (CVD) SiC fiber. (b) and (c) The composition of carbon-rich coating near the surface of carbon coated SiC fiber and SiC/C coated SiC fiber (SCS-6).

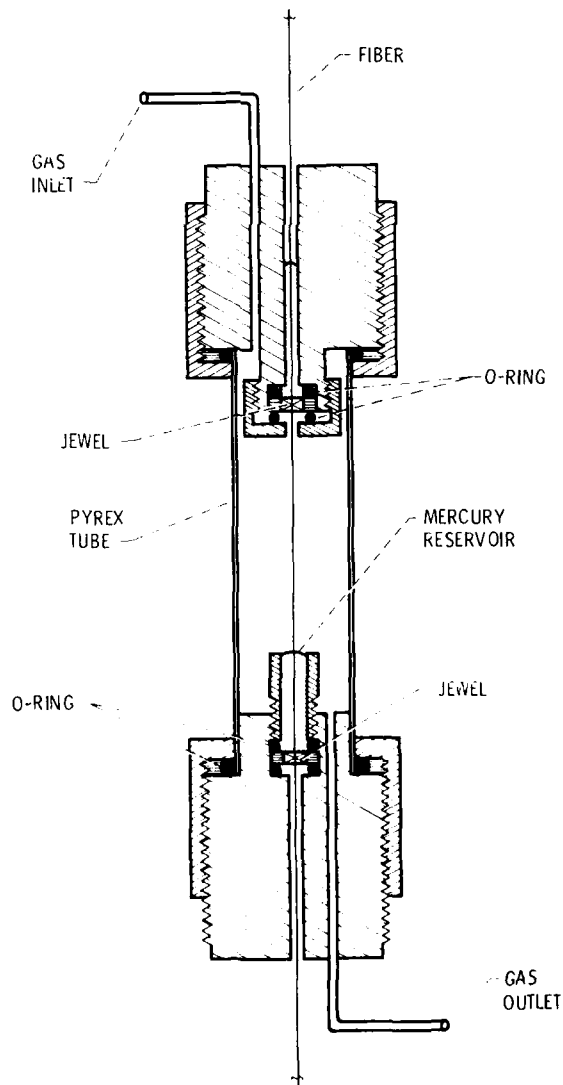

Figure 2. - Schematic diagram of the treatment and test apparatus for gaseous environments.

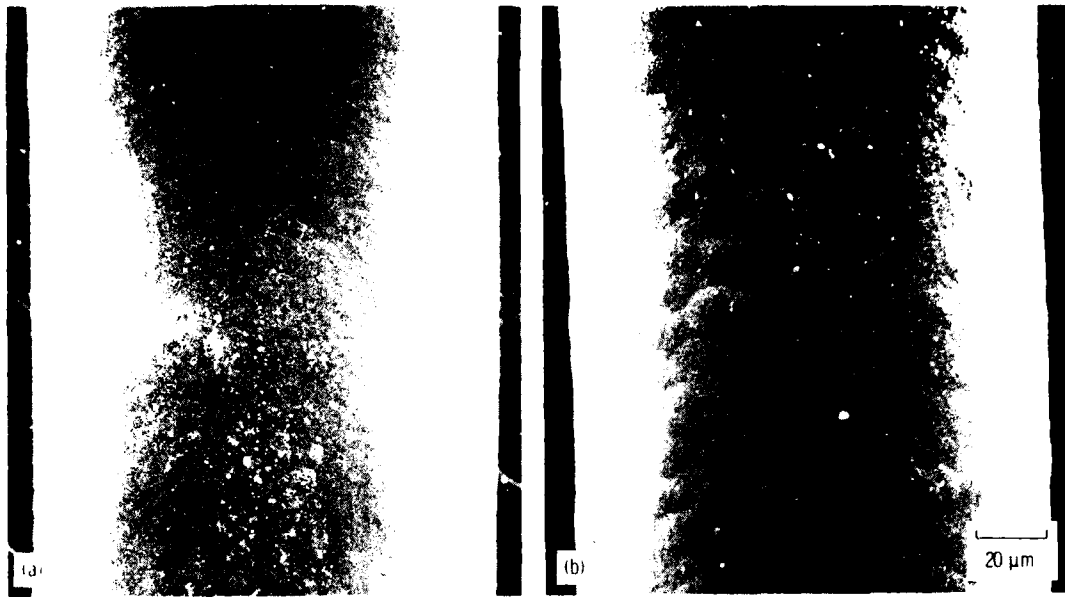

Figure 3. Photomicrographs showing surface microstructure on untreated, as-received carbon coated Saffil fibers, (a) Spool A; (b) Spool B.

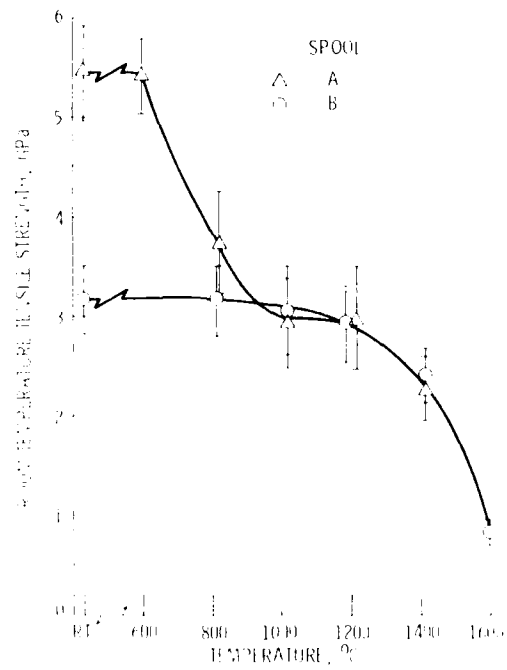

Figure 4. Tensile strength of carbon coated Saffil fibers after 15 min exposure to oxygen at indicated temperatures.

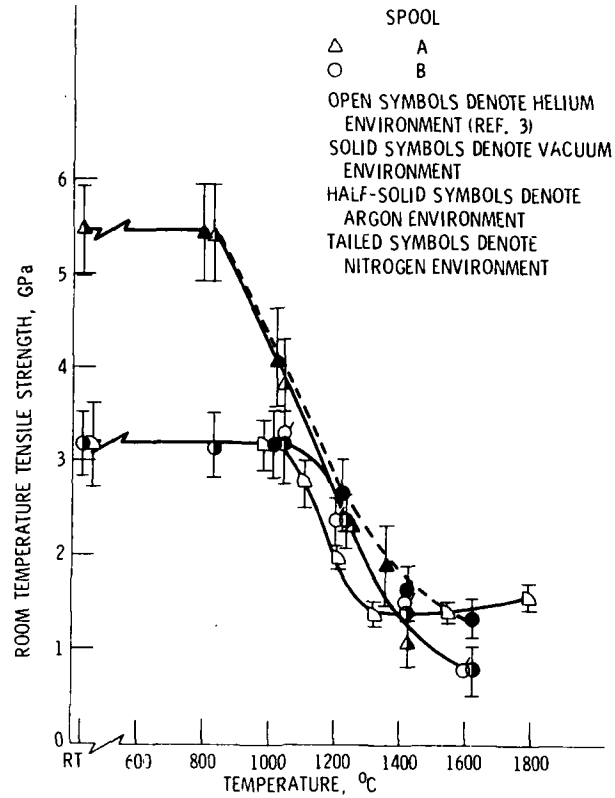

Figure 5. - Tensile strength of carbon coated SiC fibers after 15-minute exposure to various environments at indicated temperatures.

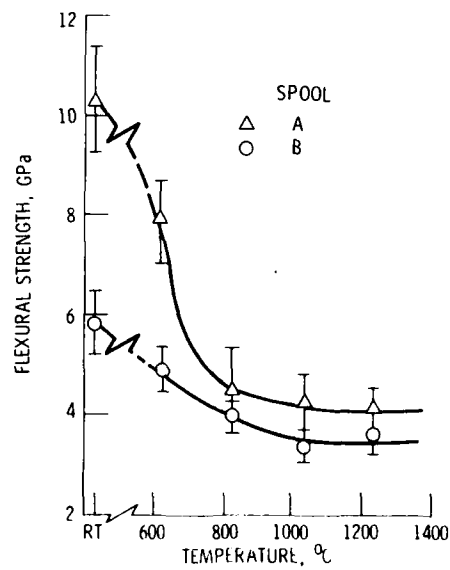

Figure 6. - Flexural strength of carbon coated SiC fibers at room temperature after 15-min exposure to oxygen at indicated temperatures.

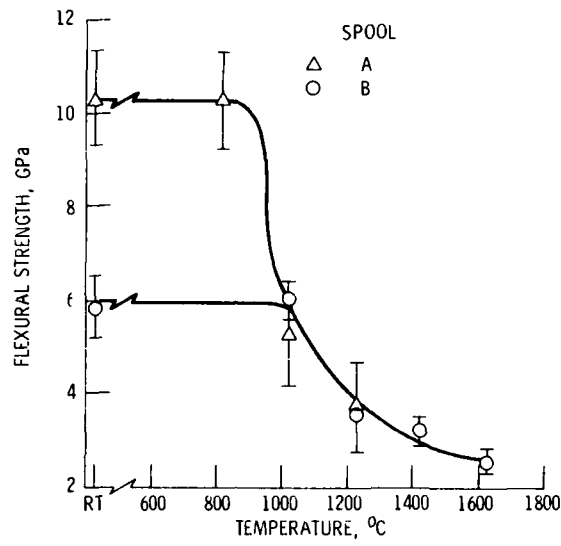

Figure 7. - Flexural strength of carbon coated SiC fibers at room temperature after 15-min exposure to vacuum at indicated temperatures.

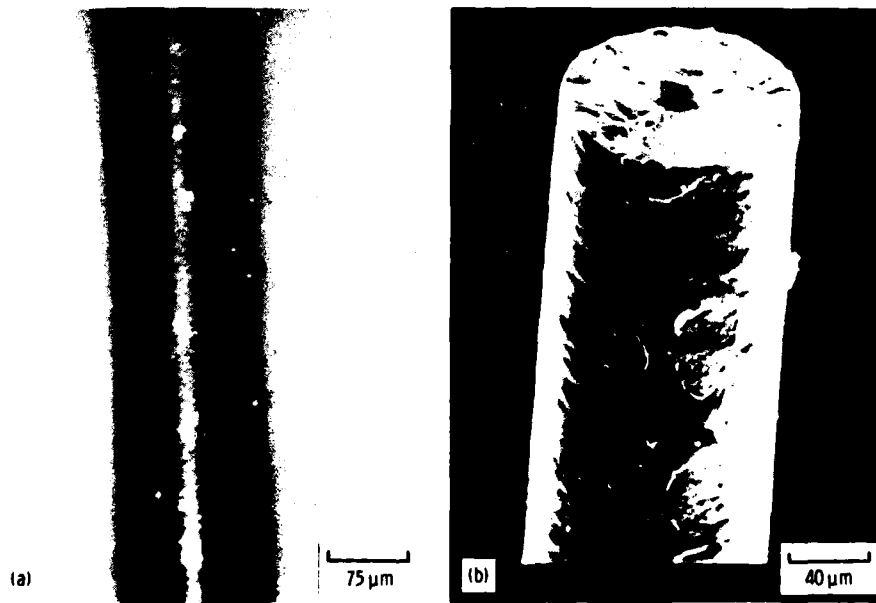

Figure 8. - (a) Photomicrograph of carbon coated SiC fiber heated at 1600 °C in air for 15 minutes showing bubbles and pits on the surface. (b) SEM photograph of a typical tensile fracture surface showing source of fracture.

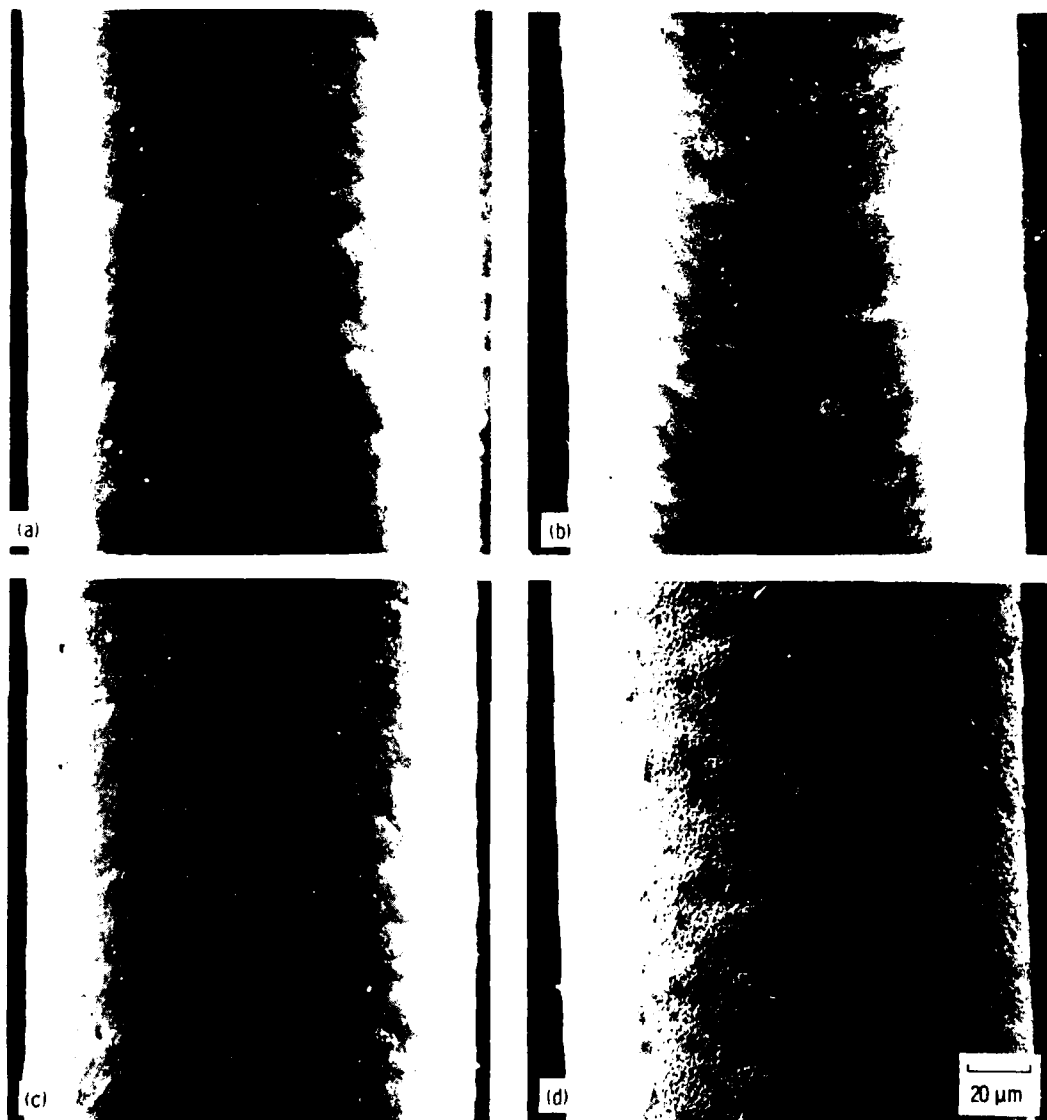

Figure 9. - SEM photographs of carbon coated SiC fiber surface before and after exposure in argon at indicated temperatures showing surface roughening. (a) As-received; (b) 1200 °C; (c) 1400 °C; (d) 1600 °C.

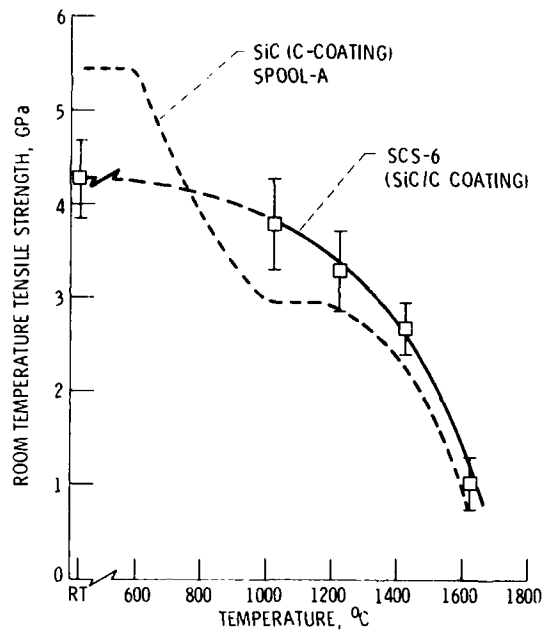

Figure 10. - Tensile strength of SCS-6 fibers after 15-min exposure to oxygen at indicated temperatures.

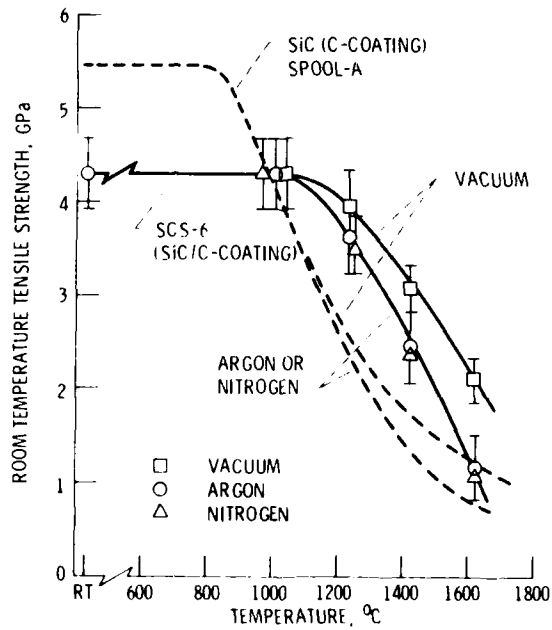

Figure 11. - Tensile strength of SCS-6 fibers after 15-min exposure to various environments at indicated temperature.

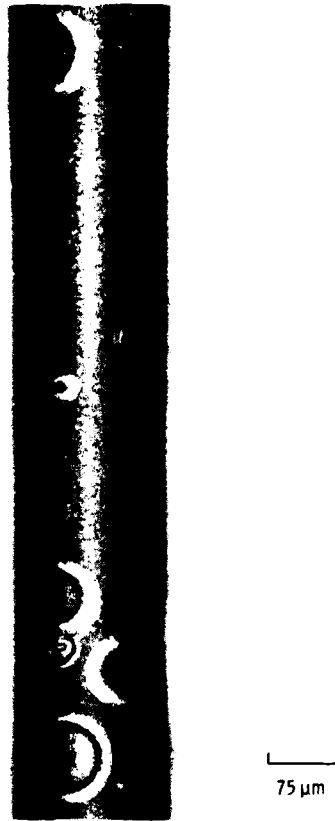

Figure 12. - Photomicrographs of SCS-6 fiber heated at 1200 °C in oxygen for 15 minutes showing pits and pinhole porosity on the surface.

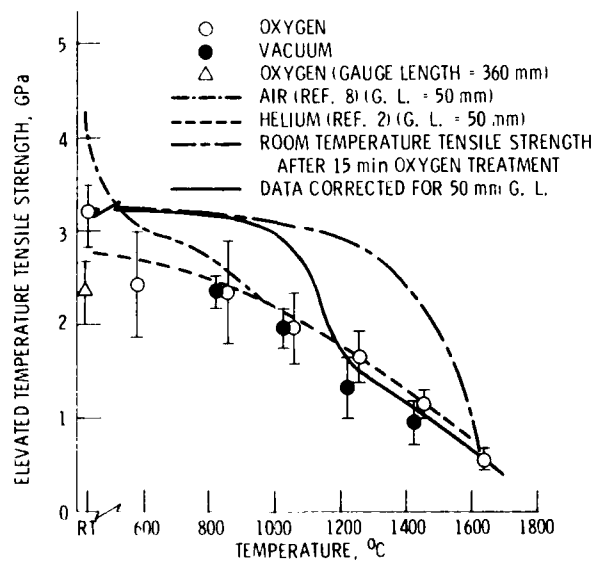

Figure 13. - Elevated temperature tensile strength of carbon coated SiC fibers after 15-min exposure to various environments at indicated temperatures.

National Aeronautics and
Space Administration

Lewis Research Center
Cleveland, Ohio 44135

Official Business
Penalty for Private Use \$300

SECOND CLASS MAIL

ADDRESS CORRECTION REQUESTED



Postage and Fees Paid
National Aeronautics and
Space Administration
NASA-451

NASA

END

FILMED

9-85

DTIC