

AD-A157 561

NATIONAL PROGRAM FOR INSPECTION OF NON-FEDERAL DAMS 1/1
CASPIAN LAKE DAM (VT. (U) CORPS OF ENGINEERS WALTHAM MA
NEW ENGLAND DIV JAN 79

UNCLASSIFIED

F/G 13/13

NL

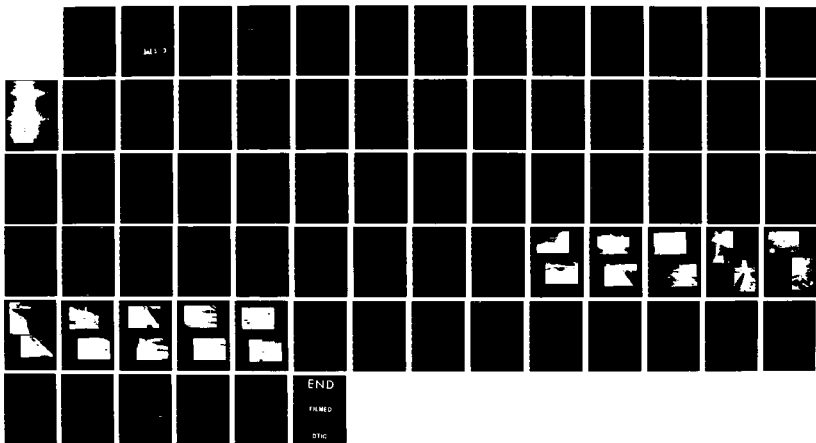

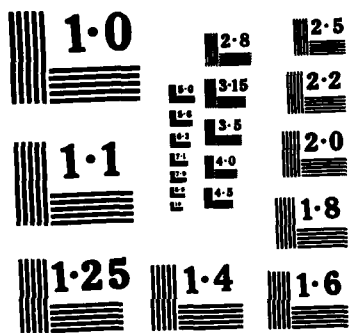

NATIONAL BUREAU OF STANDARDS
MICROCOPY RESOLUTION TEST CHART

AD-A157 561

RICHELIEU RIVER BASIN
GREENSBORO, VERMONT

CASPIAN LAKE DAM

VT 00183

PHASE I INSPECTION REPORT
NATIONAL DAM INSPECTION PROGRAM



DTIC
ELITE
JUL 19 1985
S G D

DEPARTMENT OF THE ARMY
NEW ENGLAND DIVISION, CORPS OF ENGINEERS
WALTHAM, MASS. 02154

DTIC FILE COPY

JANUARY 1979

DISTRIBUTION STATEMENT A
Approved for public release
Distribution Unlimited

85 07 01 113

UNCLASSIFIED

SECURITY CLASSIFICATION OF THIS PAGE (When Data Entered)

REPORT DOCUMENTATION PAGE		READ INSTRUCTIONS BEFORE COMPLETING FORM
1. REPORT NUMBER VT 00183	2. GOVT ACCESSION NO. AD-A157561	3. RECIPIENT'S CATALOG NUMBER
4. TITLE (and Subtitle) Caspian Lake Dam NATIONAL PROGRAM FOR INSPECTION OF NON-FEDERAL DAMS		5. TYPE OF REPORT & PERIOD COVERED INSPECTION REPORT
		6. PERFORMING ORG. REPORT NUMBER
7. AUTHOR(s) U.S. ARMY CORPS OF ENGINEERS NEW ENGLAND DIVISION		8. CONTRACT OR GRANT NUMBER(s)
9. PERFORMING ORGANIZATION NAME AND ADDRESS		10. PROGRAM ELEMENT, PROJECT, TASK AREA & WORK UNIT NUMBERS
11. CONTROLLING OFFICE NAME AND ADDRESS DEPT. OF THE ARMY, CORPS OF ENGINEERS NEW ENGLAND DIVISION, NEDED 424 TRAPELO ROAD, WALTHAM, MA. 02254		12. REPORT DATE January 1979
		13. NUMBER OF PAGES 54
14. MONITORING AGENCY NAME & ADDRESS (if different from Controlling Office)		15. SECURITY CLASS. (of this report) UNCLASSIFIED
		15a. DECLASSIFICATION/DOWNGRADING SCHEDULE
16. DISTRIBUTION STATEMENT (of this Report) APPROVAL FOR PUBLIC RELEASE: DISTRIBUTION UNLIMITED		
17. DISTRIBUTION STATEMENT (of the abstract entered in Block 20, if different from Report)		
18. SUPPLEMENTARY NOTES Cover program reads: Phase I Inspection Report, National Dam Inspection Program; however, the official title of the program is: National Program for Inspection of Non-Federal Dams; use cover date for date of report.		
19. KEY WORDS (Continue on reverse side if necessary and identify by block number) DAMS, INSPECTION, DAM SAFETY, Richelieu Rwer Basin Greensboro, VT.		
20. ABSTRACT (Continue on reverse side if necessary and identify by block number) The dam is a 205 ft. long, 7.4 ft. high dam consisting of earth, stone and concrete. The visual inspection of the embankment indicates there has been considerable deterioration of the dam since its construction prior to 1929. It is intermediate in size with a significant hazard potential. There are various remedial measures and recommendations which must be undertaken by the owner.		

DISCLAIMER NOTICE

THIS DOCUMENT IS BEST QUALITY PRACTICABLE. THE COPY FURNISHED TO DTIC CONTAINED A SIGNIFICANT NUMBER OF PAGES WHICH DO NOT REPRODUCE LEGIBLY.

CASPIAN LAKE DAM

VT 00183

RICHELIEU RIVER BASIN
GREENSBORO, VERMONT

PHASE I INSPECTION REPORT
NATIONAL DAM INSPECTION PROGRAM



Accession For	
NTIS GRA&I	<input checked="" type="checkbox"/>
DTIC TAB	<input type="checkbox"/>
Unannounced	<input type="checkbox"/>
Justification	
By _____	
Distribution/	
Availability Codes	
Dist	Avail and/or Special
A/1	23 <i>cut</i>

LETTER OF TRANSMITTAL
FROM THE CORPS OF ENGINEERS TO THE STATE
TO BE SUPPLIED BY THE CORPS OF ENGINEERS

NATIONAL DAM INSPECTION PROGRAM
PHASE I - INSPECTION REPORT
BRIEF ASSESSMENT

Identification No.: 00183
Name of Dam: Caspian Lake Dam
Town: Greensboro
County and State: Orleans, Vermont
Date of Inspection: November 10, 1978

Caspian Lake Dam is a 205 foot long, 7.4 foot high dam consisting of earth, stone and concrete. A 1.0 foot core wall extends through the embankment from the spillway to the left abutment. The fill section upstream of the core wall consists of dumped earth, stone and granite fascia. The dam section from the right abutment to the outlet works structure consists of a massive concrete gravity wall and earthfill. The appurtenant works consist of a concrete spillway with two 2.92 foot diameter openings, a spillway channel and an outlet works consisting of a 3 foot wide sluiceway with stop-logs and a mechanically operated gate. No plans, construction specifications or design calculations were available. Field measurements were taken to prepare a plan of the dam as it presently exists.

Visual inspection of the embankment indicates there has been considerable deterioration of the dam since its construction prior to 1929. In view of the height of the embankment portion of the dam, which averages about 4 feet, the low hydraulic head of a few feet and the fact that the embankment is constructed of a material which is difficult to erode, there is no immediate concern regarding the integrity of the dam. Based on these factors, the dam is judged to be in generally good condition. The inspection revealed badly disturbed slope protection at a point about 100 feet from the spillway towards the left abutment, considerable movement of the concrete core wall, trees growing on the crest, and heavy spalling, cracks and exposed reinforcing steel on the upstream face of both walls of the outlet structure. Also, some channel floor undermining of the downstream channel floor and downstream obstructions were observed.

Based on the dam's intermediate size and significant hazard classification in accordance with Corps of Engineers guidelines, the test flood is the one-half Probable Maximum Flood. The one-half PMF outflow will overtop the dam by 2.1 feet. With the water level at the top of dam the spillway will only pass 6.0 percent of the test flood outflow.

It is recommended that the owner engage a qualified engineer to further evaluate the potential for overtopping and the feasibility of significantly increasing discharge capacity. Provisions should be made by the owner to remove certain trees (Section 7) from the crest of the dam in the vicinity of the core wall, repair the broken core wall and place new slope protection as required, and repair the deteriorated concrete at the upstream face of the outlet works structure. Also, channel floor protection should be added immediately downstream of the outlet works and the downstream channel should be cleaned of overhanging trees and debris.

The recommendations and remedial measures are described in Section 7 and should be addressed within two years after receipt of this Phase I - Inspection Report by the owner.

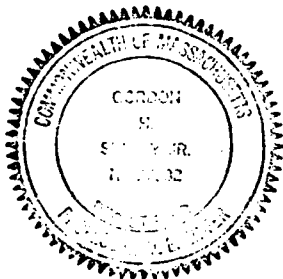

Gordon H. Slaney, Jr.

Gordon H. Slaney, Jr.
Project Engineer

Howard, Needles, Tammen & Bergendoff
Boston, Massachusetts

This Phase I Inspection Report on _____ Dam has been reviewed by the undersigned Review Board members. In our opinion, the reported findings, conclusions, and recommendations are consistent with the Recommended Guidelines for Safety Inspection of Dams, and with good engineering judgment and practice, and is hereby submitted for approval.

CHARLES G. TIERSCH, Chairman
Chief, Foundation and Materials Branch
Engineering Division

FRED J. RAVENS, Jr., Member
Chief, Design Branch
Engineering Division

SAUL COOPER, Member
Chief, Water Control Branch
Engineering Division

APPROVAL RECOMMENDED:

JOE B. FRYAR
Chief, Engineering Division

THIS SHEET TO BE FURNISHED BY THE CORPS OF ENGINEERS

PREFACE

This report is prepared under guidance contained in the Recommended Guidelines for Safety Inspection of Dams, for Phase I Investigations. Copies of these guidelines may be obtained from the Office of Chief of Engineers, Washington, D.C. 20314. The purpose of a Phase I Investigation is to identify expeditiously those dams which may pose hazards to human life or property. The assessment of the general condition of the dam is based upon available data and visual inspections. Detailed investigation and analyses involving topographic mapping, subsurface investigations, testing and detailed computational evaluations are beyond the scope of a Phase I Investigation; however, the investigation is intended to identify any need for such studies.

In reviewing this report, it should be realized that the reported condition of the dam is based on observations of field conditions at the time of inspection along with data available to the inspection team. In cases where the reservoir was lowered or drained prior to inspection, such action, while improving the stability and safety of the dam, removes the normal load on the structure and may obscure certain conditions which might otherwise be detectable if inspected under the normal operating environment of the structure.

It is important to note that the condition of a dam depends on numerous and constantly changing internal and external conditions, and is evolutionary in nature. It would be incorrect to assume that the present condition of the dam will continue to represent the condition of the dam at some point in the future. Only through continued care and inspection can there be any chance that unsafe conditions be detected.

Phase I inspections are not intended to provide detailed hydrologic and hydraulic analyses. In accordance with the established Guidelines, the Spillway Test Flood is based on the estimated "Probable Maximum Flood" for the region (greatest reasonably possible storm runoff), or fractions thereof. Because of the magnitude and rarity of such a storm event, a finding that a spillway will not pass the test flood should not be interpreted as necessarily posing a highly inadequate condition. The test flood provides a measure of relative spillway capacity and serves as an aide in determining the need for more detailed hydrologic and hydraulic studies, considering the size of the dam, its general condition and the downstream damage potential.

TABLE OF CONTENTS

<u>Section</u>	<u>Page</u>
Letter of Transmittal	
Brief Assessment	
Review Board Page	
Preface	i
Table of Contents	ii-iv
Overview Photo	v
Location Map	vi

REPORT

1. PROJECT INFORMATION	1-1
1.1 General	1-1
a. Authority	1-1
b. Purpose of Inspection	1-1
1.2 Description of Project	1-1
a. Location	1-1
b. Description of Dam and Appurtenances	1-2
c. Size Classification	1-2
d. Hazard Classification	1-2
e. Ownership	1-2
f. Operator	1-2
g. Purpose of Dam	1-3
h. Design and Construction History	1-3
i. Normal Operational Procedure	1-3
1.3 Pertinent Data	1-3
2. ENGINEERING DATA	2-1
2.1 Design Data	2-1
2.2 Construction Data	2-1
2.3 Operation Data	2-1
2.4 Evaluation of Data	2-1

<u>Section</u>	<u>Page</u>
3. VISUAL INSPECTION	3-1
3.1 Findings	3-1
a. General	3-1
b. Dam	3-1
c. Appurtenant Structures	3-2
d. Reservoir Area	3-3
e. Downstream Channel	3-3
3.2 Evaluation	3-3
4. OPERATIONAL PROCEDURES	4-1
4.1 Procedures	4-1
4.2 Maintenance of Dam	4-1
4.3 Maintenance of Operating Facilities	4-1
4.4 Description of any Warning System in Effect	4-1
4.5 Evaluation	4-1
5. HYDRAULIC/HYDROLOGY	5-1
5.1 Evaluation of Features	5-1
a. General	5-1
b. Design Data	5-1
c. Experience Data	5-1
d. Visual Observation	5-1
e. Overtopping Potential	5-1
f. Dam Failure Analysis	5-2
6. STRUCTURAL STABILITY	6-1
6.1 Evaluation of Structural Stability	6-1
a. Visual Observation	6-1
b. Design and Construction Data	6-1
c. Operating Records	6-1
d. Post-Construction Changes	6-1
e. Seismic Stability	6-1

<u>Section</u>	<u>Page</u>
7. ASSESSMENT, RECOMMENDATIONS AND REMEDIAL MEASURES	7-1
7.1 Dam Assessment	7-1
a. Condition	7-1
b. Adequacy of Information	7-1
c. Urgency	7-1
d. Need for Additional Investigation	7-2
7.2 Recommendations	7-2
7.3 Remedial Measures	7-2
7.4 Alternatives	7-2

APPENDIXES

APPENDIX A - INSPECTION CHECKLIST

APPENDIX B - ENGINEERING DATA

APPENDIX C - PHOTOGRAPHS

APPENDIX D - HYDROLOGIC AND HYDRAULIC COMPUTATIONS

APPENDIX E - INFORMATION AS CONTAINED IN THE NATIONAL
INVENTORY OF DAMS

SECTION 5
HYDROLOGY AND HYDRAULIC ANALYSIS

5.1 Evaluation of Features

a. General. Caspian Lake Dam is a composite structure consisting of earth stone, concrete and granite with a total length of approximately 205 feet and a maximum structural height of 7.4 feet. The appurtenant works consist of a concrete spillway with two 2.92 foot diameter openings, a spillway channel and an outlet works consisting of a 3 foot wide sluiceway with stoplogs and a mechanically operated gate. The outlet works is located in the original river bed of Greensboro Brook.

The dam is used primarily to raise the natural water level of Caspian Lake (natural depth is approximately 140 feet) to provide storage for hydro-electric power generation. Secondary uses included recreation and control of winter and early spring runoff. Caspian Lake Dam is classified as being intermediate having a maximum storage of 4,300 acre-feet.

b. Design Data. No hydrologic or hydraulic design data were disclosed for Caspian Lake.

c. Experience Data. The maximum discharge at this dam site is unknown. Since the reconstruction of the outlet works in 1967, a maximum depth of 13 inches over the spillway slab has been observed. This is equivalent to approximately 40 cfs. In 1927, the old dam was reported to have been almost overtopped.

d. Visual Observations. No evidence of damage to any portion of the project from overtopping was visible at the time of the inspection.

e. Overtopping Potential. As no detailed design and operational information are available, hydrologic evaluation was performed using dam information gathered by field inspection, watershed size and an estimated test flood equal to 1/2 the Probable Maximum Flood (PMF) as determined by guide curves issued by the Corps of Engineers. Based on a drainage area of 7.13 square miles, it was estimated that the test flood inflow at Caspian Lake Dam would be 6,240 cfs. Following the guidance for Estimating Effect of Surcharge Storage on Maximum Probable Discharge results in a test flood discharge of 2177 cfs. As the maximum spillway capacity at the top of the dam is only 129 cfs (approximately 6.0 percent of the test flood discharge flow), the test flood will result in the dam being overtopped by approximately 2.08 feet.

SECTION 4
OPERATIONAL PROCEDURES

4.1 Procedure

Caspian Lake Dam is used primarily to raise the natural water level of the lake to provide storage for hydro-electric power generation. Secondary uses include recreation and control of winter and early spring runoff. Discussion with the owner revealed that the operational procedure for this dam is to maintain the water level at a depth less than 4 inches above the spillway crest. There is reportedly a court order which indicates that the owner may not store water at an elevation greater than 8 inches above the spillway crest. This was established for the protection of shoreline properties, not for downstream flow control. In November of each year, the lake is lowered to channel level by opening the sluiceway. The resultant available storage is used to control snowmelt and heavy runoff during the winter and spring months. In late spring of each year, the sluiceway is closed, thus returning the reservoir level to its summertime elevation. Water from the reservoir is released as necessary for power production downstream.

4.2 Maintenance of Dam

Grounds work, painting and debris removal work are all performed on an as needed basis.

4.3 Maintenance of Operating Facilities

Maintenance on the outlet works facilities is done on an as needed basis.

During 1967, repairs were made to the dam which included the reconstruction of the outlet works structure. Present plans call for replacing the wooden gate and patching concrete at the outlet works during the winter 1978-1979.

4.4 Description of Warning Systems

There are no warning systems in effect at this facility.

4.5 Evaluation

The current operation and maintenance procedures for Caspian Lake Dam are inadequate to insure that all problems encountered can be remedied within a reasonable period of time. The owner should establish a written operation and maintenance procedure as well as establishing a warning system to follow in event of flood flow conditions or imminent dam failure.

d. Reservoir Area. The lake shoreline is lined with dwellings, behind which is heavily wooded, sloped terrain. There are no islands within the lake, which except for the approximately 4 foot (from natural channel elevation to spillway elevation) increase in depth created by the dam is a natural lake. The depth of natural lake is approximately 140 feet. The amount of siltation within the reservoir is unknown.

e. Downstream Channel. The downstream channel averages 15 feet in bottom width, with an earth and rock bottom. There are many overhanging trees along the channel, and it is obstructed about 300 feet downstream of the dam with logs and debris. Approximately 600 feet downstream, flow passes under an old mill building. There are several buildings very close to the channel. There are also a number of old walls, wooden bridges, etc. to obstruct flow. (Photos 18, 19 and 20)

3.2 Evaluation

Visual examination has revealed that there has been considerable horizontal and vertical movement of the concrete core wall and failure of a substantial section of the upstream slope protection. Deterioration of the core wall was documented in an inspection report dated March 25, 1953. This report, describing the conditions observed at that time is located in Appendix B of this report. Considering the low height of the dam and the hydraulic head of only a few feet, the dam is judged to be in generally good condition. The inspection revealed the following:

(a) At a point about 100 feet from the spillway towards the left "abutment", the slope protection has been badly disturbed.

(b) The concrete core wall has undergone considerable vertical and horizontal movement.

(c) Trees growing on the crest of the dam.

(d) Heavy spalling, cracks and exposed reinforced steel were noted on the upstream face of both walls of the outlet structure.

(e) Some channel floor undermining of the downstream channel at the outlet works.

(f) Downstream channel obstruction caused by overhanging trees and debris.

wall in good alignment except at a point just opposite a grove of cedar trees on the dam crest. The largest tree which is a few feet from the wall has a diameter of 2 feet.

Downstream

The natural topography, along with the low height of the dam, makes it difficult to discern the downstream slope in many areas. A large, low lying area downstream of the dam was traversed and no signs of seepage were observed.

c. Appurtenant Structures. Visual inspection of the concrete spillway, outlet works structure and spillway/outlet works discharge channel did not reveal any evidence of stability problems. Inspection of the appurtenant structures indicated they are in fair condition. The concrete surface appeared to be in generally good condition except for the upstream face of the sluiceway walls which have experienced considerable deterioration. Heavy spalling, cracks and exposed reinforcing steel were noted on these walls as shown in Photo 16.

The spillway section consists of a heavy concrete slab and side walls with two 2.92 foot diameter openings reinforced by corrugated metal pipe, all as shown in Figure 1, in Appendix B and Photos 2 and 14. The concrete surface of the spillway structure is in good condition.

The outlet works consist of a wooden, mechanically operated control gate and a concrete sluiceway discharge channel formed by two retaining walls, the sluiceway has a maximum effective opening of 3 feet wide by 6.6 feet high. The gate (Photo 2) was not operated but visual inspection indicated that it was in good condition, and it was reported to be operational. Inspection of the concrete walls revealed considerable concrete deterioration at the upstream face of the structure. Heavy spalling, cracks and exposed reinforcing steel were noted on both retaining walls as shown in Photo 16.

The concrete gravity retaining wall between outlet works structure and the right "abutment" of the dam appears to be in stable and good condition; some cracks and spalling, however, were noted as shown in Photo 8.

Visual inspection of the spillway/outlet works discharge channel showed it to be in generally good condition. The right bank of the channel is reinforced by a flat stone retaining wall (Photo No. 17). There appears to be some channel floor undermining at the outlet works structure. There are a few overhanging trees that would appear to obstruct free flow of the channel discharge.

SECTION 3
VISUAL INSPECTION

3.1 Findings

a. General. The field inspection of Caspian Lake was made on November 10, 1978. The inspection team consisted of personnel from Howard, Needles, Tammen & Bergendoff and Geotechnical Engineers, Inc. A representative of the Town of Hardwick owner of the dam, was also present during a portion of the inspection. Inspection checklists, completed during the visual inspection are included in Appendix A. At the time of the inspection, the water level was approximately 4 inches below the permanent spillway elevation. No water was passing over the spillway. The upstream face of the dam could only be inspected above this water level.

b. Dam. Visual inspection of the embankment indicates there has been considerable deterioration of the dam since its construction prior to 1929. In view of the height of the embankment portion of the dam, which averages about 4 feet, the low hydraulic head of a few feet and the fact that the embankment is constructed of a material which is difficult to erode, there is no immediate concern regarding the integrity of the dam.

Upstream Slope

The upstream slope of the dam is protected by cut granite slabs about 4 inches thick. The slope protection is shown in Photo 7.

At a point about 100 feet from the spillway towards the left "abutment" the slope protection has been badly disturbed. Photos 10, 11 and 12 show this area where the granite slabs have been displaced and the fill between the core wall and the granite slabs has been washed away.

Crest

The crest of the dam is composed of bouldery till and is about 6 inches below the top of the concrete core wall, as shown in Photos 9 and 10. The concrete core wall has undergone considerable vertical and horizontal movement, as shown in Photo 12. This photo was taken at the end of the core wall which is about 120 feet from the spillway.

The movement of the core wall may be the result of pressure exerted by roots of the trees which have grown immediately upstream of the disturbed core wall. Photos 9 and 10 show the

SECTION 2
ENGINEERING DATA

2.1 Design

No original design data were disclosed for Caspian Lake. The dam was originally constructed prior to 1929. It has been reported that the main section of the dam was reconstructed in 1948 in accordance to plans prepared by Charles T. Main, Inc. The present outlet works were reported to have been constructed in about 1967, but no plans were found to be available at this time.

2.2 Construction

No construction records were available for use in evaluating the dam.

2.3 Operation

No engineering operational data were disclosed.

2.4 Evaluation

a. Availability. Little engineering data were available for Caspian Lake Dam. A search of the files of the Vermont Department of Water Resources and discussion with the owner revealed only a limited amount of recorded information.

b. Adequacy. The lack of in-depth engineering data did not allow for a definitive review; therefore, the adequacy of this dam could not be assessed from the standpoint of reviewing design and construction data, but is based primarily on visual inspection, past performance history and sound engineering judgment.

c. Validity. The field investigation indicated that the external features of Caspian Lake Dam substantially agree with those described on past inspection reports.

(3) Crest Elevation - 1,400.0.

(4) Gates - None.

(5) U/S Channel - none.

(6) Downstream Channel. The downstream channel averages 15 feet in bottom width, with an earth and rock bottom. There are many overhanging trees along the channel, and it is obstructed about 300 feet downstream of the dam with logs and debris. Flow passes under an old mill building, and there are several buildings very close to the channel. There are a number of old walls, wood bridges, etc. to obstruct flow.

j. Regulating Outlets. The lake level is regulated by a three (3) foot wide sluiceway located to the right of the spillway and controlled by a mechanically operated gate. The control for the gate is located on the top slab of the outlet works structure as shown in Figure 1, located in Appendix B. Invert of the sluiceway is at the stream bed level or elevation 1,396.

- (2) Flood Control Pool - 4,300.
- (3) Spillway Crest Pool - 2,300.
- (4) Top of Dam - 4,300.

f. Reservoir Surface (Acres) Vertical Sides Assumed.

- (1) Recreation Pool - 800.
- (2) Flood Control Pool - 800.
- (3) Spillway Crest - 800.
- (4) Test Flood Pool - 800.
- (5) Top Dam - 800.

g. Dam

- (1) Type - earth and rock dam.
- (2) Length - 205.0 feet, overall.
- (3) Height - 7.4 feet (maximum).
- (4) Top Width - 8 feet.
- (5) Side Slopes - US = 2:1; DS = variable.
- (6) Zoning - unknown.
- (7) Impervious core - foot thick concrete wall.
- (8) Cutoff - unknown.
- (9) Grout Curtain - unknown.
- (10) Other - none.

h. Diversion and Regulating Tunnel

None.

i. Spillway

- (1) Type - 2-2'-11" CMP set 8" in spillway slab. (Photo 2)
- (2) Length of Weir - N/A.

lowered about 7.4 feet below the dam crest elevation of 1403.6 by opening the sluiceway gate. This drawdown would lower the lake to its natural lake elevation of 1,396.0.

(2) There is no data regarding the maximum discharge. However, a maximum depth of 13" over the spillway slab has been noted since its installation in 1967. This is equivalent to approximately 40 cfs. In 1927, the old dam was almost overtopped.

(3) Spillway capacity with the water surface at the top of the dam is approximately 129 cfs at elevation 1403.6 feet.

(4) Spillway capacity with the water surface at the test flood elevation of 1,405.68 is approximately 530 cfs.

(5) The total project discharge at the test flood elevation of 1,405.68 is approximately 2,177 cfs.

c. Elevation (feet above MSL)

- (1) Streambed at centerline of dam - 1,396.
- (2) Maximum tailwater - unknown.
- (3) Upstream portal invert diversion tunnel - none.
- (4) Recreation pool - 1,400.0.
- (5) Full flood control pool - 1403.6.
- (6) Spillway crest (permanent spillway) - 1,400.0.
- (7) Design surcharge - unknown.
- (8) Top Dam - 1403.6.
- (9) Test Flood Surcharge - 1,405.68.

d. Reservoir (miles)

- (1) Length of Maximum Pool - 1.6.
- (2) Length of Recreational Pool - 1.6.
- (3) Length of Flood Control Pool - 1.6.

e. Storage (gross acre-feet)

- (1) Recreation Pool - 2,300.

g. Purpose of Dam. This dam was constructed to raise the natural water level on the lake to provide storage for hydro-electric power generation. The lake is also used for recreation, and some flood control benefits which are described in Section 4, Operational Procedures.

h. Design and Construction History. No design or construction data were disclosed for the Caspian Lake Dam. The dam was originally constructed prior to 1929. It has been reported that the main section of the dam was reconstructed in 1948 in accordance with plans prepared by Charles T. Main, Inc. The present outlet works were constructed in about 1967.

i. Normal Operating Procedure. There are no written operational procedures for this dam. Discussion with the owner revealed that the dam is used primarily to raise the natural water level of the lake to provide storage for hydro-electric power generation. Secondary uses include recreation and control of winter and early spring runoff. The normal operational procedure for this dam is to maintain the water level at a depth of less than 4 inches above the spillway crest. There is reportedly a court order which indicates that the owner may not store water at an elevation greater than 8 inches above the spillway crest. This was established for the protection of shoreline properties, not for downstream flow control. In November of each year, the lake is lowered to channel level by opening the sluiceway. The resultant available storage is used to control snowmelt and heavy runoff during the winter and spring months. In late spring of each year, the sluiceway is closed, thus returning the reservoir level to its summertime elevation.

1.3 Pertinent Data

a. Drainage Area. The drainage area tributary to Caspian Lake consists of 7.13 square miles of rolling wooded terrain. The watershed outside of the lake area is relatively undeveloped with some roads, but no large concentration of dwellings. Elevation in the basin varies from a maximum of 2,200 feet MSL to 1,400 feet MSL. The natural depth of Caspian Lake is approximately 140 feet.

The lake shoreline is lined with dwellings behind which is heavily wooded, sloped terrain. There are no islands in the lake. Seventeen percent of the watershed is taken up by Caspian Lake.

b. Discharge at Dam Site

(1) The outlet works for Caspian Lake Dam consists of one three (3) foot wide sluiceway set at the stream bed elevation of about 1,396 MSL. The lake behind the dam can

b. Description of Dam and Appurtenances. Caspian Lake Dam is a composite structure consisting of earth, stone, concrete and granite. The dam's length, including the sluiceway/spillway structure, is approximately 205 feet from the left abutment to the right abutment. The maximum structural height of the dam is about 7.4 feet. A 1.0 foot core wall extends through the embankment from the spillway to the left abutment. The height of the core wall is not known, but is assumed to be equal to the height of the dam. The fill section upstream of the core wall consists of dumped earth, stone and granite fascia placed on a side slope of about 2 feet horizontal to 1 foot vertical (2:1). The fill on the downstream face of the dam is assumed to be earth material as shown in Section A-A, Figure 1, in Appendix B. The dam section from the right abutment to outlet works structure consists of a massive concrete gravity wall and earthfill, again as shown on Figure 1.

The appurtenant works consists of a concrete spillway with two 2 foot - 11 inch diameter pipes embedded in an 8 inch thick spillway slab, spillway channel and an outlet works consisting of a sluiceway with stoplogs and a mechanically operated gate. The spillway/sluiceway structure is located in the original Greensboro Brook bed.

Figure 1, located in Appendix B, shows the plan of the dam and its appurtenant structures. Photographs of each structure are shown in Appendix C.

c. Size Classification. Intermediate (hydraulic height - 7 feet high, storage - 4,300 acre-feet) based on storage ($\geq 1,000$ to 50,000 acre-feet) as given in Recommended Guidelines for Safety Inspection of Dams.

d. Hazard Classification. The dam's potential threat to life and property rates it as a significant hazard classification. A major breach could result in damage to several buildings downstream. However, the flood wave would largely be confined within the channel as the stage would be approximately 5 feet. Downstream damage would be further amplified due to the manmade constrictions in the channel, particularly the old mill building and roadway, under which the channel passes.

e. Ownership. This dam is owned by the Village of Hardwick, Vermont.

f. Operator. This dam is maintained and operated by the Village of Hardwick, Vermont. The Superintendent of the Light Department, located in the Memorial Building, is Mr. Rupert Peake. Telephone No. (802) 427.5971.

NATIONAL DAM INSPECTION PROGRAM
PHASE I INSPECTION REPORT
CASPIAN LAKE DAM

SECTION 1
PROJECT INFORMATION

1.1 General

a. Authority. Public Law 92-367, August 8, 1972, authorized the Secretary of the Army, through the Corps of Engineers, to initiate a National Program of Dam Inspection throughout the United States. The New England Division of the Corps of Engineers has been assigned the responsibility of supervising the inspection of dams within the New England Region. Howard, Needles, Tammen & Bergendoff has been retained by the New England Division to inspect and report on selected dams in the State of Vermont. Authorization and notice to proceed were issued to Howard, Needles, Tammen & Bergendoff under a letter of October 23, 1978 from John P. Chandler, Colonel, Corps of Engineers. Contract No. DACW33-78-C-0356 has been assigned by the Corps of Engineers for this work.

b. Purpose

(1) To perform technical inspection and evaluation of non-Federal dams to identify conditions which threaten the public safety and thus permit correction in a timely manner by non-Federal interests.

(2) To encourage and prepare the states to initiate quickly effective dam safety program for non-Federal dams.

(3) To update, verify and complete the National Inventory of Dams.

1.2 Description of Project

a. Location. The Caspian Lake Dam is located on Greensboro Brook approximately 3.7 miles upstream of its confluence with Lamoille River in the Town of Greensboro, Vermont. The dam location is shown on U.S.G.S. Quadrangle Hardwick, Vermont, with coordinates approximately N44°34'36", W72°17'55", Orleans County, Vermont. The location of Caspian Lake is shown on the Location Map immediately preceding this page.

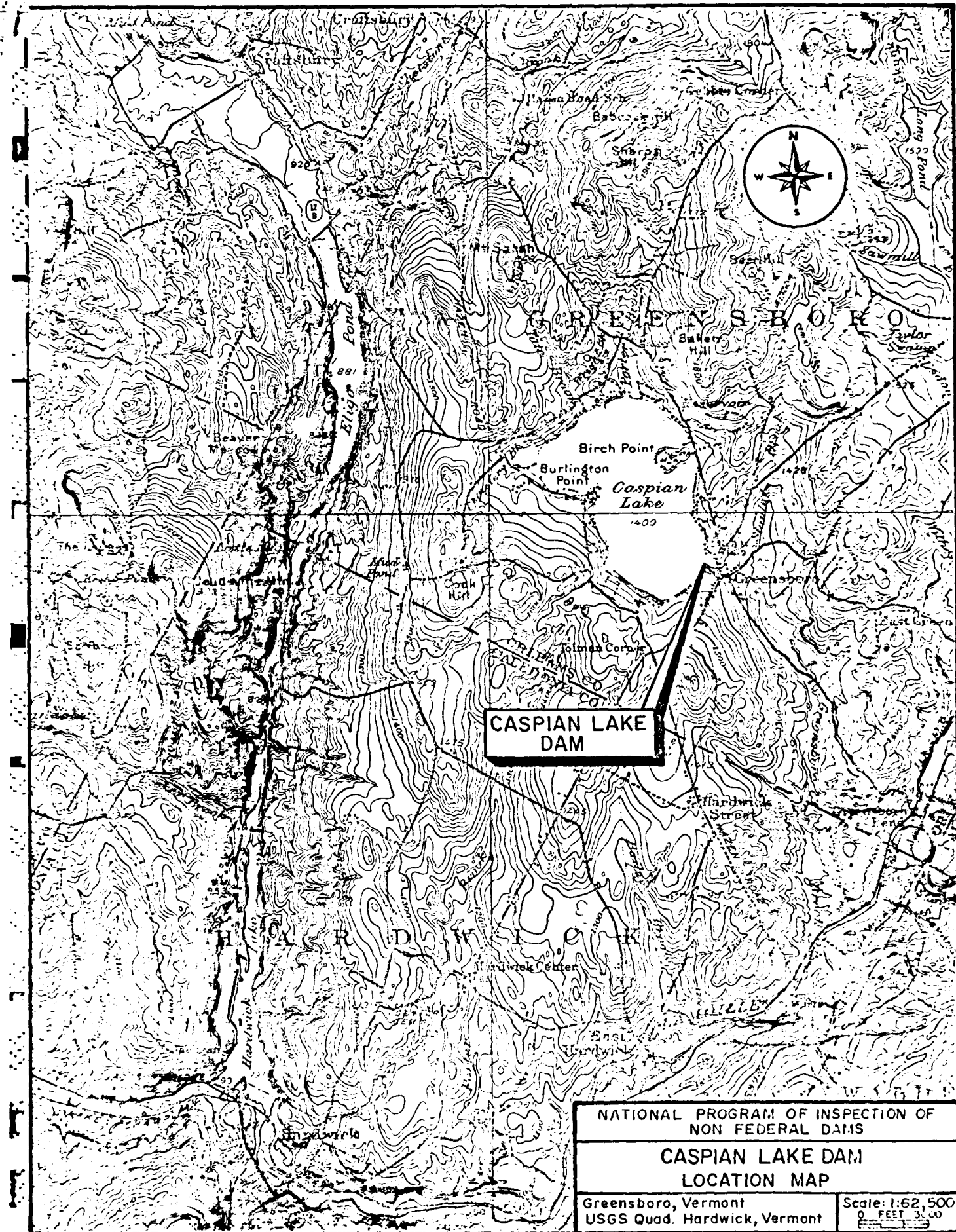

CASPIAN LAKE DAM

NATIONAL PROGRAM OF INSPECTION OF NON FEDERAL DAMS	
CASPIAN LAKE DAM LOCATION MAP	
Greensboro, Vermont USGS Quad. Hardwick, Vermont	Scale: 1:62,500 0 FEET 3500

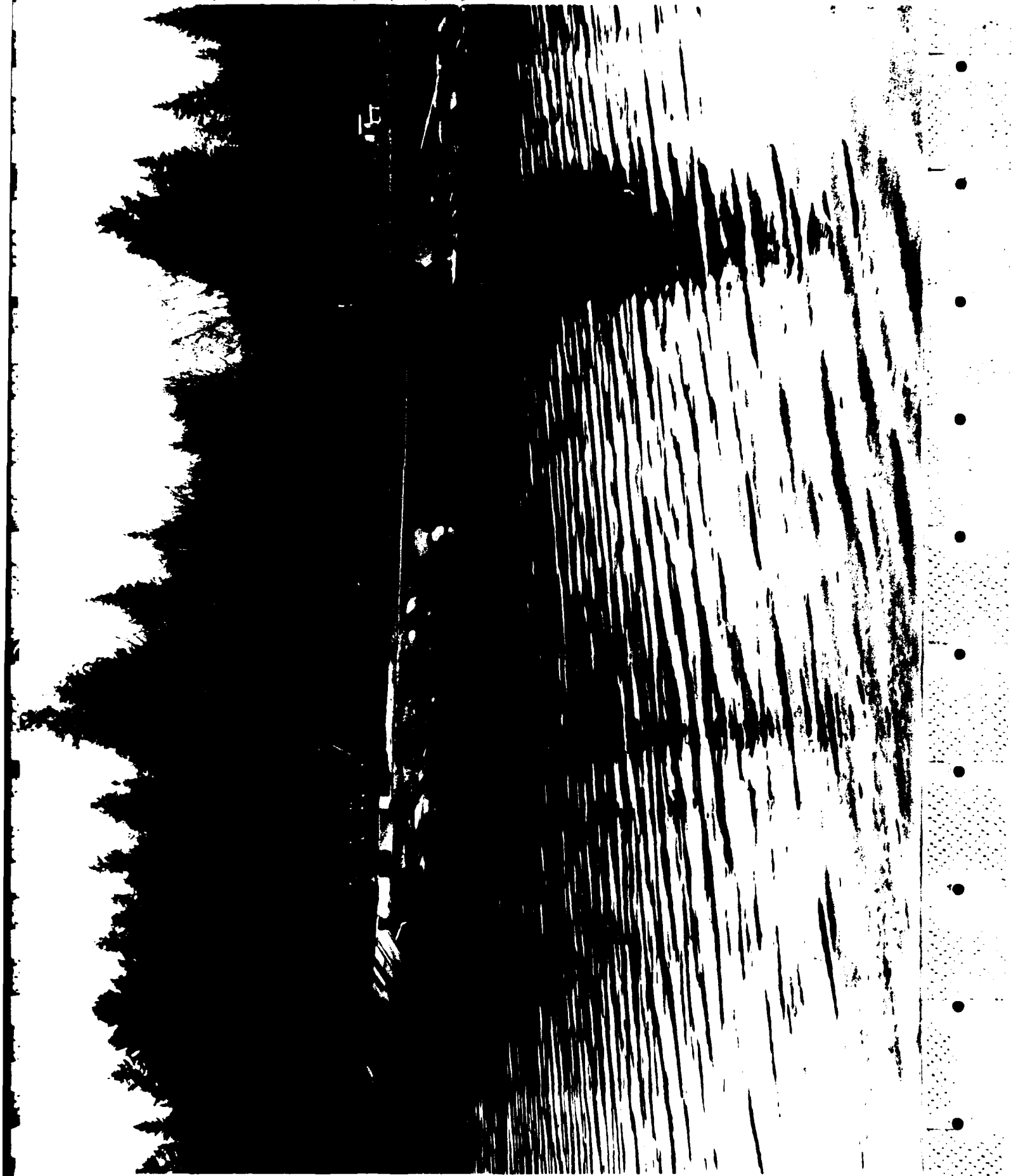

CASPIAN LAKE DAM - Overview looking downstream

f. Dam Failure Analysis. The impact of failure of the dam at maximum pool (top of dam) was assessed using the "Rule of Thumb" Guidance for Estimating Downstream Dam Failure Hydrographs issued by the Corps of Engineers. The analysis covered the reach extending from the dam to a point 2,600 feet downstream or past the built up area of Greensboro.

Failure of the dam would probably result in a downstream flood stage of $4\frac{1}{2}$ feet. If failure occurred at a pool elevation equal to the top of dam, spillway flow would be negligible (85 cfs). The flood wave should be contained within the channel banks except where obstructions occur. Between the dam and the roadway downstream, a distance of about 600 feet, there are several dwellings along the bank of the channel, the lowest being about 5 feet above the channel bottom. At the downstream roadway, the channel passes under an old mill building, currently being used as a commercial building, and then continues to pass under the roadway and between two commercial buildings downstream. Damage to structures on the streambanks would probably occur through debris carried by the flood wave and would probably be amplified by backwater conditions created by headlosses created at the entrance to the old mill building. As the flood wave would probably be confined to a narrow area, hazard to life would be minimal. It is quite likely that a large discharge resulting from test flood flows would pose a greater hazard than would occur under breach failure analysis.

SECTION 6
STRUCTURAL STABILITY

6.1 Evaluation of Structural Stability

a. Visual Observations. The visual inspection disclosed that a substantial section of the concrete core wall and up-stream slope protection has failed. An inspection report by the Vermont Public Service Commission dated March 25, 1953, stated "...the retaining wall protecting the north earth abutment is in poor condition. It is cracked and decomposed in places." A copy of this 1953 inspection report is located in Appendix B of this report.

Based on this report, the deteriorated condition has existed for 25 years without detrimental effects. Due to the low hydraulic head (a few feet) and the natural topography of the area which would allow water from a failure at this section to flow into Greensboro Brook, this condition is not judged as an immediate safety problem.

b. Design and Construction Data. No design or construction data pertaining to the original dam is available.

c. Operating Records. No operating records were made available.

d. Post-Construction Changes. Caspian Lake Dam was originally constructed prior to 1929. It has been reported that the main section of the dam was reconstructed in 1948 in accordance with plans prepared by Charles T. Main, Inc. The present outlet works were constructed in about 1967.

e. Seismic Stability. The dam is located in Seismic Zone 2, and in accordance with recommended Phase I guidelines does not warrant seismic analysis.

SECTION 7
ASSESSMENT, RECOMMENDATIONS AND REMEDIAL MEASURES

7.1 Dam Assessment

a. Condition. The visual inspection of Caspian Lake Dam indicates that the dam is in generally good condition. The inspection revealed the following:

(1) There has been a failure of the concrete core wall and granite slab upstream slope protection at a point about 100 feet from the spillway towards the left abutment.

(2) Trees growing on the crest of the dam.

(3) Heavy spalling, cracks and exposed reinforcing steel were noted on the upstream face of both walls of the outlet structures.

(4) Some channel floor undermining of the downstream channel at the outlet works.

(5) Downstream channel obstruction caused by overhanging trees and by a log and debris dam.

The condition described in (1) above and shown in Photos 10, 11 and 12 is not judged as an immediate safety problem for the following reasons:

(1) The height of the embankment is 3 to 4 feet.

(2) The hydraulic head across the dam is only a few feet.

(3) The embankment is constructed out of bouldery glacial till which would be erosion resistant in the event of a local failure.

The hydraulic analysis reveals that the dam cannot pass the required test flood without overtopping the dam.

b. Adequacy of Information. The lack of in-depth engineering data did not allow for a definitive review. Therefore, the adequacy of this dam could not be assessed from the standpoint of reviewing design and construction data, but is based primarily on visual inspection, past performance history and in sound engineering judgment.

c. Urgency. This dam, for the reasons described in Section 3.2, is considered to be in generally good condition. The recommendations and remedial measures described in Sections 7.2 and 7.3 should be accomplished within 2 years after receipt of this Phase I Inspection Report by the owner.

d. Necessity of Additional Investigation. The findings of the visual investigation indicates that an additional investigation is not necessary.

7.2 Recommendations

It is recommended that the owner engage a qualified engineer to further evaluate the potential for overtopping and the inadequacy of the spillway.

7.3 Remedial Measures

(a) The overhanging tree shown in Photo 9 should be removed from the crest of dam.

(b) The broken core wall should be repaired and new slope protection placed as required.

(c) The upstream face of both walls of the outlet works structure should be repaired.

(d) Channel floor protection should be provided immediately downstream of the outlet works structure.

(e) The downstream channel should be cleaned of overhanging trees and the debris dam.

(f) A written operational procedure and warning system to follow in the event of flood flow conditions or imminent dam failure should be developed. The warning system should discuss the operation of the gates during flood flow conditions and the steps to be taken by local officials for alerting downstream residents in case of emergency.

(g) A periodic technical inspection program should be initiated on a biennial basis.

7.4 Alternatives

There are no practical alternatives to the recommendations of Section 7.2 and 7.3.

APPENDIX A
VISUAL CHECKLIST WITH COMMENTS

VISUAL INSPECTION CHECK LIST
PARTY ORGANIZATION

PROJECT Caspian Lake Dam

DATE Nov. 10, 1978

TIME 8 A.M.

WEATHER Sunny

W.S. ELEV. 1399.7 U.S. 1397 DN.S

PARTY:

- | | |
|-------------------------------|-----------|
| 1. <u>Gordon Slaney, HNTB</u> | 6. _____ |
| 2. <u>Stan Mazur, HNTB</u> | 7. _____ |
| 3. <u>Dan LaGatta, GEI</u> | 8. _____ |
| 4. _____ | 9. _____ |
| 5. _____ | 10. _____ |

PROJECT FEATURE	INSPECTED BY	REMARKS
1. <u>Embankment Dam</u>	<u>D. LaGatta</u>	
2. <u>Spillway, Sluiceway</u>	<u>S. Mazur, G. Slaney</u>	
3. _____		
4. _____		
5. _____		
6. _____		
7. _____		
8. _____		
9. _____		
10. _____		

PERIODIC INSPECTION CHECK LIST

PROJECT Caspian Lake Dam

DATE Nov. 10, 1978

PROJECT FEATURE Embankment Dam

NAME D. P. LaGatta

DISCIPLINE Geotechnical Engineer

NAME _____

AREA EVALUATED	CONDITION
<u>DAM EMBANKMENT</u>	
Crest Elevation	1402.75
Current Pool Elevation	1399.7
Maximum Impoundment to Date	Nearly overtopped in 1927 (1403+)
Surface Cracks	Numerous cracks in core wall.
Pavement Condition	No pavement.
Movement or Settlement of Crest	Based on observation of core wall,
Lateral Movement	there has been movement of the embankment both vertically and horizontally.
Vertical Alignment	See Photos 10 and 12
Horizontal Alignment	
Condition at Abutment and at Concrete Structures	Good.
Indications of Movement of Structural Items on Slopes	Substantial movement of core wall and granite slabs forming slope protection.
Trespassing on Slopes	None.
Sloughing or Erosion of Slopes or Abutments	There has been erosion of the upstream slope beneath the granite slabs. Photo 10
Rock Slope Protection - Riprap Failures	The slope protection consists of 4" thick granite slabs which have become displaced and broken.
Unusual Movement or Cracking at or near Toes	None observed.
Unusual Embankment or Downstream Seepage	None observed.
Piping or Boils	None observed.
Foundation Drainage Features	None.
Toe Drains	None.
Instrumentation System	None.
Vegetation	Large trees on crest.

PERIODIC INSPECTION CHECK LIST

PROJECT Caspian Lake Dam

DATE Nov. 10, 1978

PROJECT FEATURE Control Tower

NAME _____

DISCIPLINE Structural Engineer

NAME S. Mazur

AREA EVALUATED

CONDITION

OUTLET WORKS - CONTROL TOWER

a. Concrete and Structural

General Condition

Condition of Joints

Spalling

Visible Reinforcing

Rusting or Staining of Concrete

Any Seepage or Efflorescence

Joint Alignment

Unusual Seepage or Leaks in Gate Chamber

Cracks

Rusting or Corrosion of Steel

b. Mechanical and Electrical

Air Vents

Float Wells

Crane Hoist

Elevator

Hydraulic System

Service Gates

Emergency Gates

Lightning Protection System

Emergency Power System

Wiring and Lighting System

This facility has no tower.

PERIODIC INSPECTION CHECK LIST

PROJECT Caspian Lake Dam

DATE Nov. 10, 1978

PROJECT FEATURE Transition and Conduit

NAME _____

DISCIPLINE _____

NAME _____

AREA EVALUATED

CONDITION

OUTLET WORKS - TRANSITION AND CONDUIT

General Condition of Concrete

None.

Rust or Staining on Concrete

Spalling

Erosion or Cavitation

Cracking

Alignment of Monoliths

Alignment of Joints

Numbering of Monoliths

PERIODIC INSPECTION CHECK LIST

PROJECT Caspian Lake Dam

DATE Nov. 10, 1978

PROJECT FEATURE Embankment Dam

NAME D. P. LaGatta

DISCIPLINE Geotechnical/Structural/Hydraulic
Engineers

NAME S. Mazur, G. Slaney

AREA EVALUATED	CONDITION
<p><u>OUTLET WORKS - OUTLET STRUCTURE AND OUTLET CHANNEL</u></p>	
<p>General Condition of Concrete</p>	<p>Sluiceway, which is only way of out- letting water other than the spillway, consists of mechanically operated wooden gate. Gate and concrete in fair condition.</p>
<p>Rust or Staining</p>	<p>None.</p>
<p>Spalling</p>	<p>Upstream face of sluiceway structure heavy spalling.</p>
<p>Erosion or Cavitation</p>	<p>Some at upstream face.</p>
<p>Visible Reinforcing</p>	<p>None.</p>
<p>Any Seepage or Efflorescence</p>	<p>Good.</p>
<p>Condition at Joints</p>	<p>None.</p>
<p>Drain Holes</p>	<p>None.</p>
<p>Channel</p>	
<p>Loose Rock or Trees Overhanging Channel</p>	<p>Some trees on shoreline on natural brook forming outlet channel should be cut back.</p>
<p>Condition of Discharge Channel</p>	

PERIODIC INSPECTION CHECK LIST

PROJECT Caspian Lake Dam

DATE Nov. 10, 1978

PROJECT FEATURE Spillway/Channel

NAME D. P. LaGatta

DISCIPLINE Geotechnical/Structural/Hydraulic
Engineers

NAME S. Mazur, G. Slaney

AREA EVALUATED	CONDITION
<p><u>OUTLET WORKS - SPILLWAY WEIR, APPROACH AND DISCHARGE CHANNELS</u></p>	
<p>. Approach Channel</p>	None.
<p> General Condition</p>	
<p> Loose Rock Overhanging Channel</p>	
<p> Trees Overhanging Channel</p>	
<p> Floor of Approach Channel</p>	
<p>. Weir and Training Walls</p>	
<p> General Condition of Concrete</p>	Good.
<p> Rust or Staining</p>	None.
<p> Spalling</p>	None.
<p> Any Visible Reinforcing</p>	None.
<p> Any Seepage or Efflorescence</p>	None.
<p> Drain Holes</p>	None.
<p>. Discharge Channel</p>	
<p> General Channel</p>	Same as outlet channel.
<p> Loose Rock Overhanging Channel</p>	
<p> Trees Overhanging Channel</p>	
<p> Floor of Channel</p>	
<p> Other Obstructions</p>	

PERIODIC INSPECTION CHECK LIST

PROJECT Caspian Lake Dam

DATE Nov. 10, 1978

PROJECT FEATURE _____

NAME _____

DISCIPLINE _____

NAME _____

AREA EVALUATED	CONDITION
<p><u>LET WORKS - SERVICE BRIDGE</u></p> <p>Super Structure</p> <p> Bearings</p> <p> Anchor Bolts</p> <p> Bridge Seat</p> <p> Longitudinal Members</p> <p> Under Side of Deck</p> <p> Secondary Bracing</p> <p> Deck</p> <p> Drainage System</p> <p> Railings</p> <p> Expansion Joints</p> <p> Paint</p> <p>Abutment & Piers</p> <p> General Condition of Concrete</p> <p> Alignment of Abutment</p> <p> Approach to Bridge</p> <p> Condition of Seat & Backwall</p>	<p>This facility has no service bridge.</p>

APPENDIX B

1. LIST OF DESIGN, CONSTRUCTION AND MAINTENANCE RECORDS
2. PLANS AND DETAILS
3. PAST INSPECTION REPORTS



PHOTO NO. 9 - Crest
of dam from spill-
way structure
to left "abutment"

PHOTO NO. 10 - Upstream face of
dam at end of concrete core
wall near left abutment about
120 feet from spillway. Note,
collapse of granite slope
protection due to washing out
of fill beneath slabs.





PHOTO NO. 7 - Upstream face of dam
from spillway structure to
left "abutment".

PHOTO NO. 8 - Upstream face of
dam from spillway structure
to right "abutment".





PHOTO NO. 5 - View of dam from left abutment.



PHOTO NO. 6 - Upstream slope of the dam at right abutment.



PHOTO NO. 3 - View of dam from lake side.



PHOTO NO. 4 - View of dam from left abutment.



PHOTO NO. 1 - General view of dam and reservoir.



PHOTO NO. 2 - View of reservoir, downstream channel and elevation of spillway - outlet works structure.

APPENDIX C

PHOTOGRAPHS

FOR LOCATION OF PHOTOS, SEE FIGURE 1
LOCATED IN APPENDIX B

in accordance with plans drawn up by Chas. T. Main, Inc., Engineers. This newer section remains in an excellent condition.

The older portion, i.e., the retaining wall protecting the north earth abutment is in poor condition. It is cracked and decomposed in places. Its extreme end has sustained a failure due to wave and ice action. In spite of the condition of this wall, the earth abutment is not, as yet, adversely affected.

In general, lake levels are maintained which allow for added storage capacity and freeboard. With such operation, the lake can absorb flood flows of the Nov. 1927 Flood variety.

It will be noted that the outlet channel has natural earth material for the floor. Excessive flows at full capacity or so may scour the base material. Thus, for this reason and, also because of restricted channel conditions in the outlet brook at Greensboro village, maximum flows should be controlled.

Conclusions

For its rating as a relatively important dam, all is satisfactory except for some needed repairs of a secondary nature.

Stephen H. Haybrook

STEPHEN H. HAYBROOK
HYDRAULIC ENGINEER

Public Service Commission

March 25, 1953

Electric

REPORT ON CASPIAN LAKE DAM

This report on Caspian Lake dam supersedes an earlier, sketchy report on the structure. It follows a re-inspection of the dam on March 20, 1953.

General

This dam also referred to as the Greensboro dam, is owned and operated by the Village of Hardwick. It is located at the outlet of a natural lake in the town of Greensboro. It creates storage for hydro-electric use on the Lamoyille River.

At full level the lake has a surface area given as 789 acres. The useable volume is estimated at 100,000,000 cu. ft. The drainage area is 8 sq. mi.

Description of Dam

This dam is a small concrete structure on a hard pan foundation. The main portion of the dam is a low, 3 ft. thick section about 87 ft. long. At maximum depth, it has an open, rectangular outlet channel, 6.5 ft. high and 3 ft. wide, controlled by a wooden lift gate. Adjacent and north of this waterway are two half-circle notches, 3 ft. wide and 2 ft. below the top of the wall, for overflow at high pond levels. The wall is banked on both sides with stone and gravel. The north abutment of earth is protected by a small, upstream retaining wall one foot higher in elevation and about 150 ft. long.

Comments on Inspection

The original dam was built prior to the Legislative Act on dams as established in 1929. The main section was rebuilt in 1948,

VILLAGE OF HARDWICK

GUY W. LARRABEE
CLERK AND TREASURER
HARDWICK, VERMONT
TEL. 171

*Dams: Hydro-
electric*

June 29, 1954.

Public Service Commission
State of Vermont
Montpelier, Vt.

Gentlemen:

Per your request dated May 25th. regarding the condition of Dams owned by the Village of Hardwick.

Dam at Wolcott Plant

Location: Lamoille River, Wolcott
Inspector: Guy W. Larrabee, Supt.
Date: June 20th. 1954
Result: New in 1948, condition good.

Dam Jackson Bridge

Location: Lamoille River, Hardwick
Inspector: Guy W. Larrabee, Supt.
Date: June 21th. 1954
Results: Reconditioned 1952, condition good.

Dam Caspian Lake

Location: Greensboro
Inspector: Guy W. Larrabee, Supt.
Date: June 26, 1954
Results: Condition good.

Dam Mackville

Location: Hardwick, Vt. Nichols Brook
Inspector: Fred Atkins, Plant Operator
Date: June 21, 1954
Results: Dam is safe enough, built of granite. needs facing on up stream side to prevent waste of water, this is first dam above the wheel.

PAST INSPECTION REPORTS

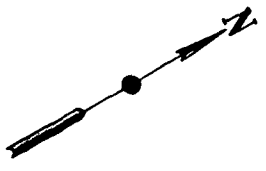
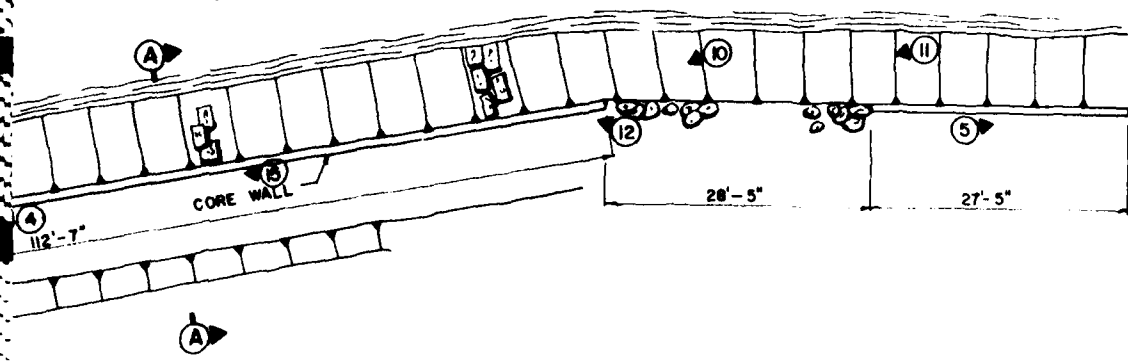

PLAN

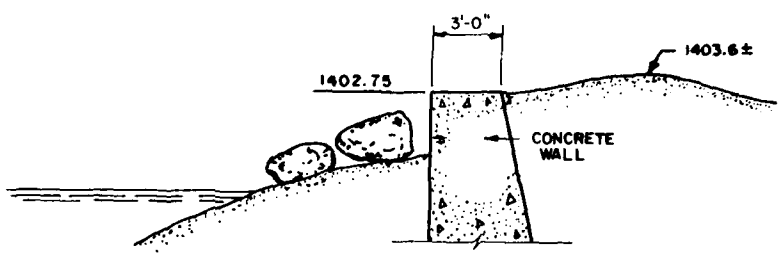

SECTION E-E

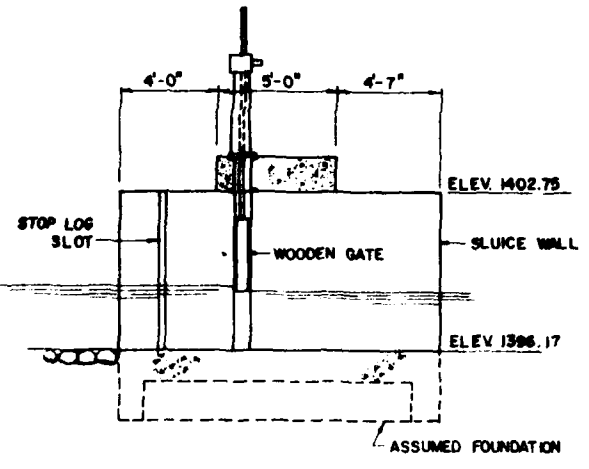

SECTION B-B

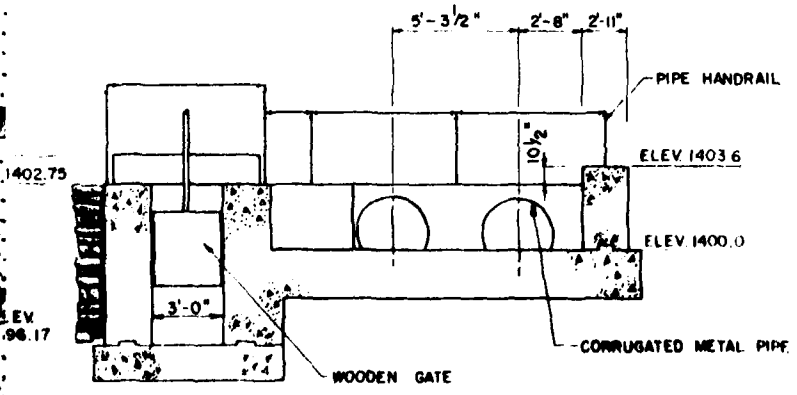

SECTION D-D

- 1 THE INFORMATION SHOWN ON THIS DRAWING IS BASED ON APPROXIMATE MEASUREMENTS AND VISUAL OBSERVATIONS MADE DURING THE FIELD INSPECTION. DIMENSIONS OR MATERIALS INDICATED ON THESE DRAWINGS WHICH WERE BELOW GRADE OR WATER DURING THE TIME OF INSPECTION, ARE ASSUMED
- 2 THE ELEVATIONS SHOWN ARE BASED ON AN ELEVATION OF 1400' SHOWN ON USGS QUADRANGLE SHEET ASSUMED TO BE POOL ELEVATION AT PERMANENT SPILLWAY CREST.

<small>DESIGNED BY: [blank]</small> <small>DRAWN BY: [blank]</small>	<small>U.S. ARMY ENGINEERING CENTER</small> <small>WATERWAYS EXPERIMENTAL STATION</small> <small>WETLANDS DIVISION</small>
NATIONAL PROGRAM OF INSPECTION OF NON-FED DAMS	
CASPIAN LAKE DAM	
<small>CASPIAN LAKE OUTLET</small>	<small>GREENSBORO VERMONT</small>

OTHER UPSTREAM

AN LAKE

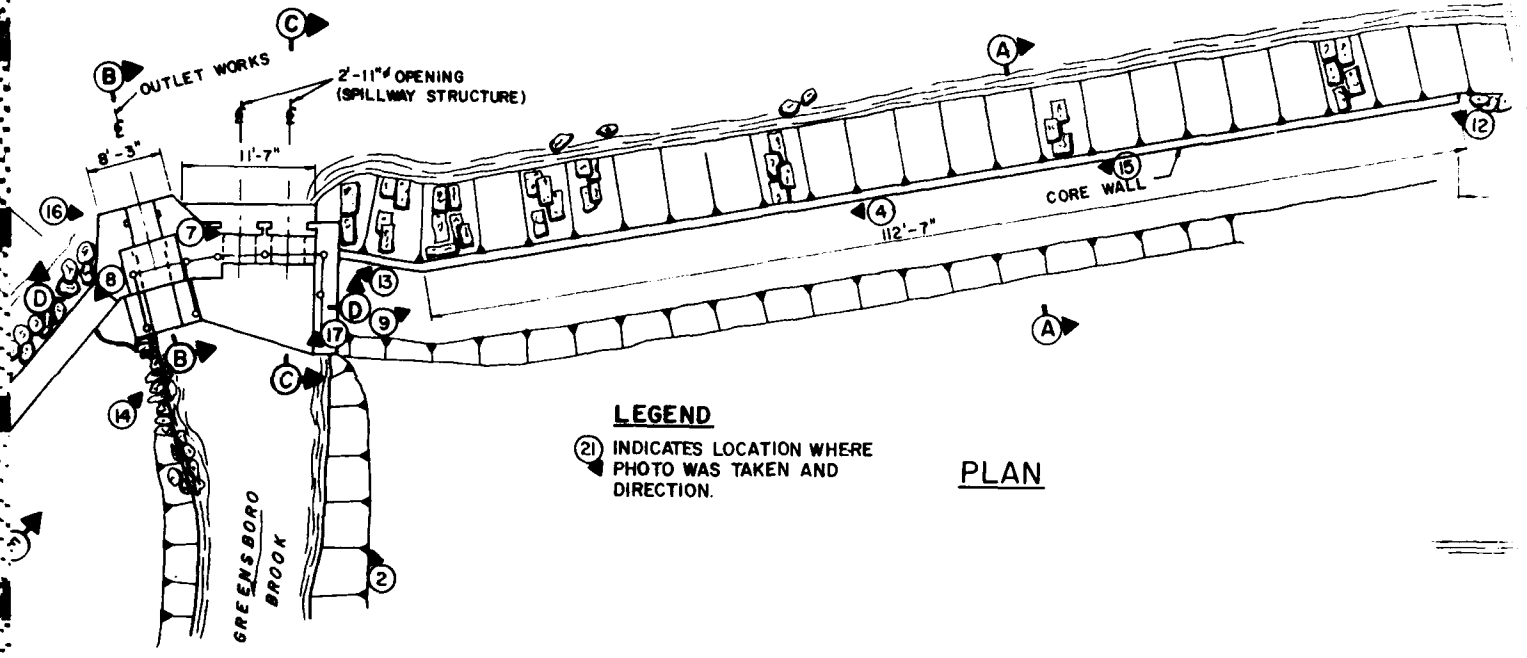

LEGEND
 (21) INDICATES LOCATION WHERE PHOTO WAS TAKEN AND DIRECTION.

PLAN

(18) (19) THESE THREE PHOTOS TAKEN FURTHER DOWNSTREAM.
 (20)

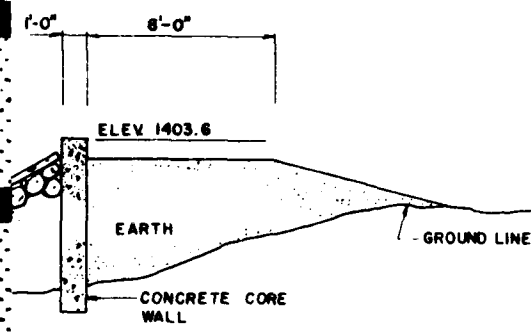

CROSS SECTION A-A

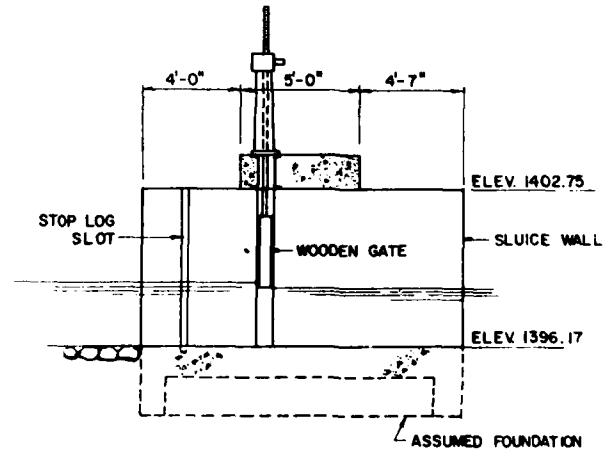

SECTION B-B

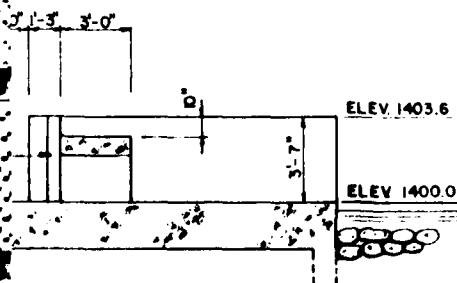

CROSS SECTION C-C

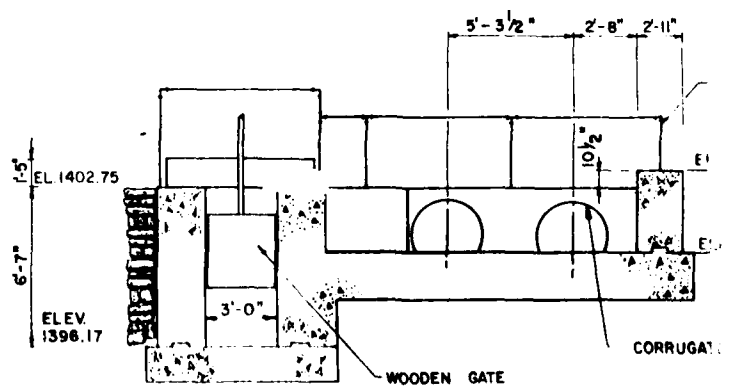

SECTION D-D

③ THIS PHOTO TAKEN FURTHER UPSTREAM

CASPIAN LAKE

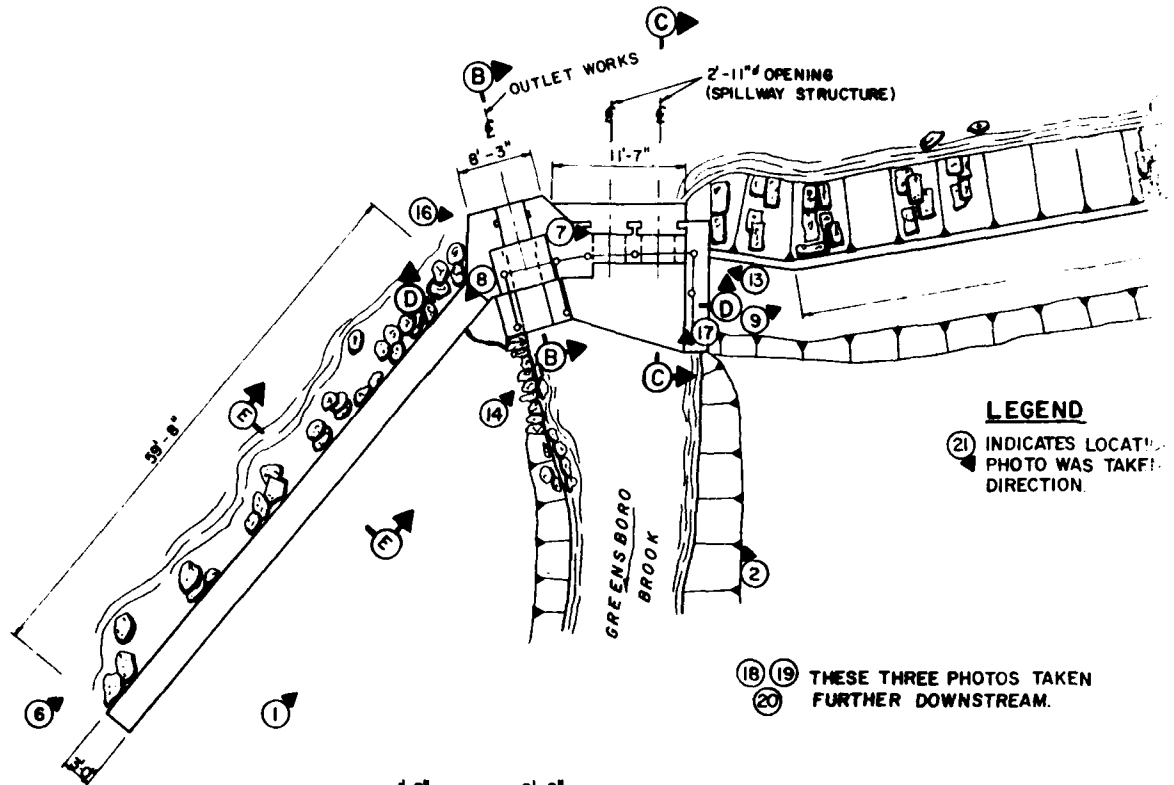

LEGEND

②① INDICATES LOCATION PHOTO WAS TAKEN
DIRECTION

⑱ ⑲ THESE THREE PHOTOS TAKEN FURTHER DOWNSTREAM.
⑳

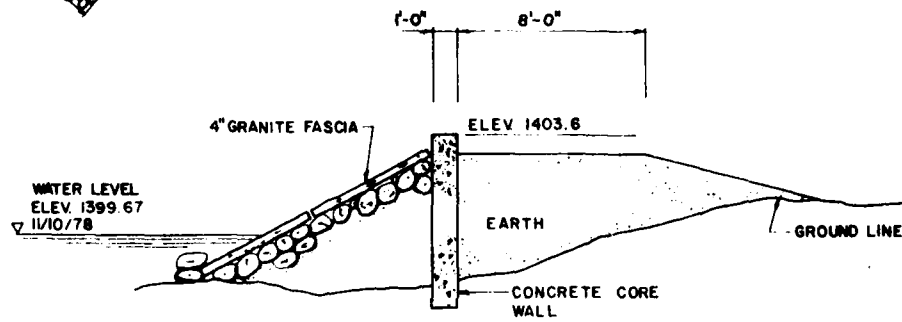

SECTION A-A

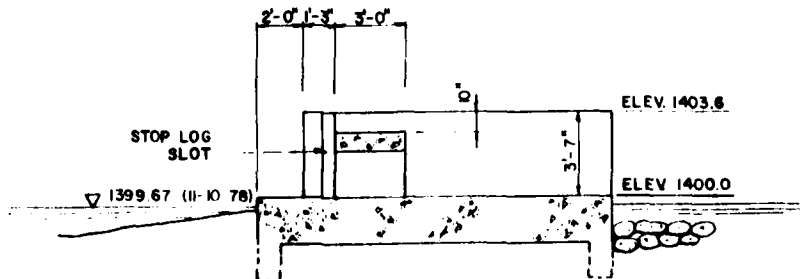

SECTION C-C

AVAILABLE ENGINEERING DATA

No drawings, specifications or other engineering data were located for this dam by either the Vermont Department of Water Resources, the Vermont Public Service Board or the Town of Hardwick, owners of the dam.



PHOTO NO. 11 - Slope protection on left "abutment" beyond concrete core wall.



PHOTO NO. 12 - Close-up of washout under slope protection. Notice horizontal movement of concrete core wall towards lake.



PHOTO NO. 13 - View of spillway and outlet works structure.



PHOTO NO. 14 - Elevation of spillway structure from downstream channel.



PHOTO NO. 15 - Erosion of upstream slope of the dam.



PHOTO NO. 16 - Deterioration of training walls at outlet works structure.

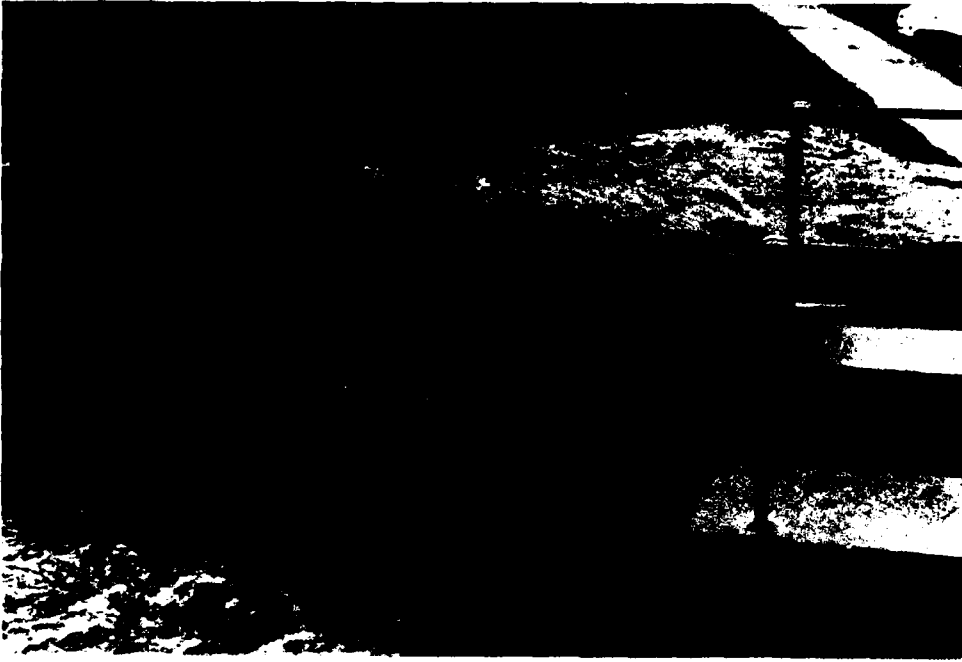

PHOTO NO. 17 - View of discharge channel with
right training wall.



PHOTO NO. 18 - View of discharge channel
(Greensboro Brook) at Greensboro
Village.



PHOTO NO. 19 - Discharge channel at old village mill house.



PHOTO NO. 20 - Discharge channel below the old village mill house.

APPENDIX D
HYDROLOGIC AND HYDRAULIC COMPUTATIONS

HNTB

WARD NEEDLES TAMMEN & BERGENDOFF

Made by

R.Y.

Date

11/21/78

Job No.

5628-11-21

Checked by

[Signature]

Date

1/16/79

Sheet No.

1

Caspian LakeHYDRAULICS & HYDROLOGYCaspian Lake Dam Located in GREENSBORO, Vt.ACROSS GREENSBORO BROOK in the
Saint Lawrence River BasinCLASSIFICATION

size: Intermediate

hazard: significant

Basic Data

D.A. = 7.13 sqmi. (HNTB calculation)

Upstream Basin: Use Rolling Curve Reservoir
AREA = 17% OF BASIN AREA

Reservoir: Normal Pool elev. 1400.0

Storage = 2300 acre-ft

Max. Pool elev. 1402.75

Storage = 4300 acre-ft

Surface: 800 acres

Dam: Earth & Rock - concrete core wall

8 ft max. height (structural)

145' spillway & dam & outlet works

60' retaining wall

Spillway: concrete

2-24" CMP's inv. 1400.0

Outlet: 3' wide sluiceway w/ wood gate

invert 1396.17 = stream

Caspian Lake

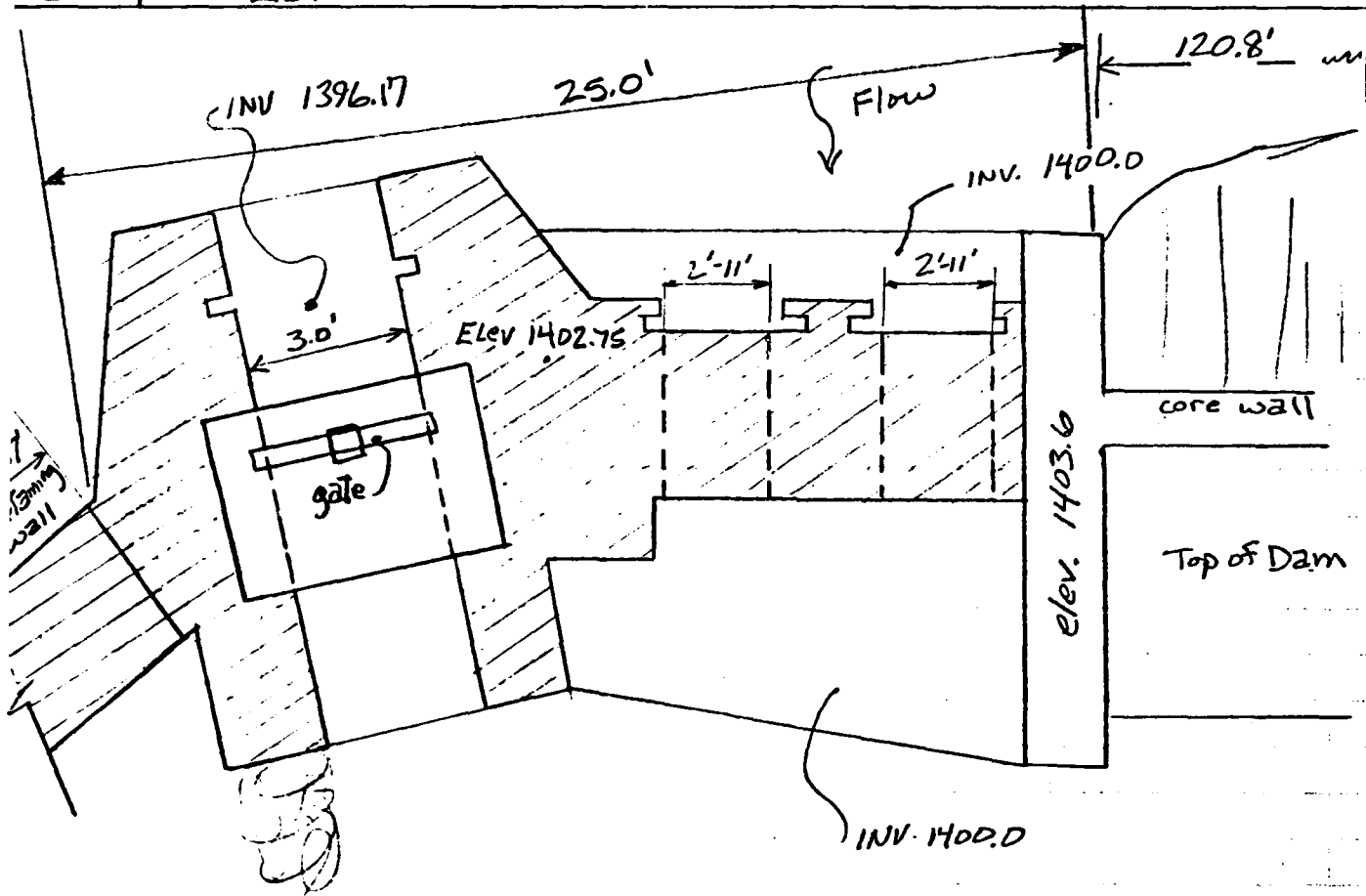

Plan of Spillway
(no scale)

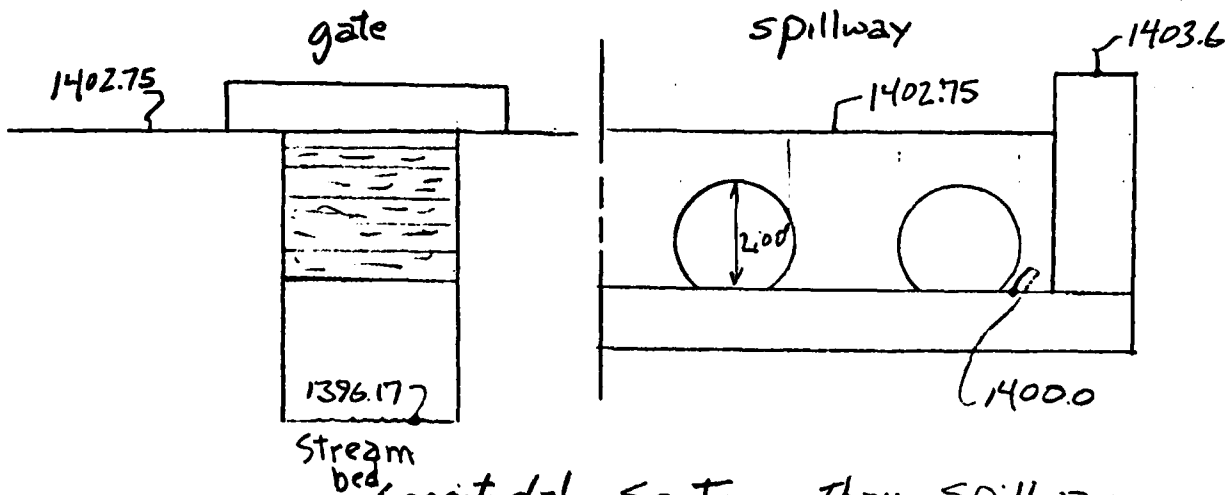

Longitudinal Section Thru Spillway
& outlet

Caspian LakeSTEP 1 Calculation of Spillway Design Flood

Classification size: intermediate
hazard: significant

Hydrologic Evaluation Guideline Recommends:

1/2 PMF to PMF use 1/2 PMF as res. storage
or low side of classification
range

$$PMF = 1750 \text{ cfs/sq.mi.} -$$

$$\frac{1}{2} \times 1750 \text{ cfs/sq.mi.} \times 7.13 \text{ sq.mi.} = 6,238 \text{ cfs}$$

Use $Q = 6240 \text{ cfs}$
for SDF

STEP 2 Calculation of Surcharge by 1/2 PMF

1/2 PMF = Spillway Design Flood =

Consider: Gate in open position (normal winter set)
Steep downstream channel will result
in low tailwater conditions.
Tailwater effects negligible on dam

Spillway - Spillway outlet will be under orifice
conditions when pool is at or above
elev. 1402.75.
Invert = 1400.0

$$Q_s = C a \sqrt{2gh}$$

$C = 0.60$ circular orifice

$a = 2 \times 4.88 \text{ sq.ft.}$ (pipe partially set in concrete)

$$Q_s = (0.6)(2)(4.88) \sqrt{2g} \sqrt{h} = 46.99 \sqrt{h}$$

$$Q_s = 47.0 \sqrt{h}$$

aspian Lake

*Outlet works Use 3' wide x 3.5' high opening
Drifize type flow conditions*

$$Q_0 = C a \sqrt{2gh}$$

*C = 0.60 square type opening
a = 3' x 3.5' = 10.5 ft²*

$$Q_0 = 0.60 (10.5) \sqrt{2g} \sqrt{h} = 50.5 \sqrt{h}$$

$$Q_0 = 50.5 \sqrt{h}$$

1m Crest Diagram

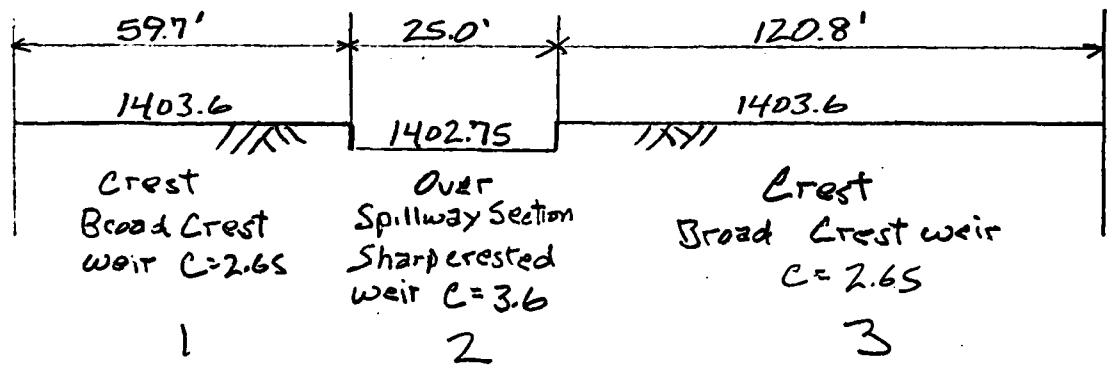

$$Q_{1-3} = CLH^{3/2}$$

$$Q_1 = 2.65 (59.7) h_1^{3/2} = 158.2 h_1^{3/2}$$

$$Q_2 = 3.60 (25) h_2^{3/2} = 90 h_2^{3/2}$$

$$Q_3 = 2.65 (120.8) h_3^{3/2} = 320.1 h_3^{3/2}$$

$$h_1 = h_3$$

$$Q_{1+3} = 478.3 h_1^{3/2}$$

Stage-Discharge See Fig 1

<i>h₁(ft)</i>	<i>Q₁₊₃</i>	<i>h₂</i>	<i>Q₂</i>	<i>h₃</i>	<i>Q₃</i>	<i>h₀</i>	<i>Q₀</i>	<i>Q_{total}</i>
0	0	0	.	.75	41	3.08	89	130
.0	0	.85	70	1.6	59	3.93	100	230
1.4	792	2.25	303	3.0	81	5.33	116	1294
3.4	2998	4.25	788	5.0	105	7.33	137	4029
6.4	7744	7.25	1757	8.0	133	10.33	162	9796
8.4	11644	9.25	2532	10.0	149	12.33	177	14502

ITB

NEEDLES TAMMEN & BERGENDOFF

Made by RY

Date 2/22/79

Job No 5628-11-21

Checked by

Date

Sheet No. 5

spian Lake

Step 3 Effect of Surcharge on Test Flood Inflow

$$Q_{P_1} = 6240 \text{ cfs}$$

As. 1/2 P.M.F. used Runoff = 9.5 in

$$\text{Surcharge}_1 = 1408.29 - 1402.75 = 5.54 \text{ ft}$$

$$\text{Stor}_1 = \frac{5.54 \text{ ft} \times 12 \text{ in/ft} \times 800 \text{ acres}}{7.13 \text{ Sq mi} \times 640 \text{ acre/mi}^2} = 2.10 \times 5.54 = 11.65 \text{ in}$$

Use = 9.5 in

$$Q_{P_2} = Q_{P_1} \left(1 - \frac{\text{Stor}_1}{9.5}\right) = 6250 \left(1 - \frac{9.5}{9.5}\right) = 0 \text{ cfs}$$

$$\text{Stor}_2 = 0$$

$$\text{Stor}_{\text{AVE}_1} = \frac{0 + 9.5}{2} = 4.75 \text{ in}$$

$$Q_{P_3} = 6240 \left(1 - \frac{4.75}{9.5}\right) = 3120 \text{ cfs}$$

$$\text{Surcharge}_3 = 1406.38 - 1402.75 = 3.63 \text{ ft}$$

$$\text{Stor}_3 = 2.10 \times 3.63 = 7.62 \text{ in}$$

$$\text{Stor}_{\text{AVE}_2} = \frac{7.62 + 4.75}{2} = 6.19 \text{ in}$$

$$Q_{P_4} = 6240 \left(1 - \frac{6.19}{9.5}\right) = 2177 \text{ cfs}$$

$$\text{Surcharge}_4 = 1405.68 - 1402.75 = 2.93 \text{ ft}$$

$$\text{Stor}_4 = 2.10 \times 2.93 = 6.15 \text{ in}$$

ITB

NEEDLES TAMMEN & BERGENDOFF

Made by

RY

Date

12/14/78

Job No.

5628-11-21

Checked by

WVW

Date

1/16/79

Sheet No.

6

Caspian

Stor values close. use Q_{py} as Outflow

2177 cfs outflow

1405.68 Surge Elevation

2.93 ft over top of Spillway

2.08 ft over dam crest

Conclusions

Reservoir Storage reduces the spillway design flood inflow from 6240 cfs to 2177 cfs or by 65%.

The spillway & storage capacity can safely pass 6.0% of the test flood.

At the test flood discharge of 2177 cfs the dam crest will be overtopped by 2.08 ft.

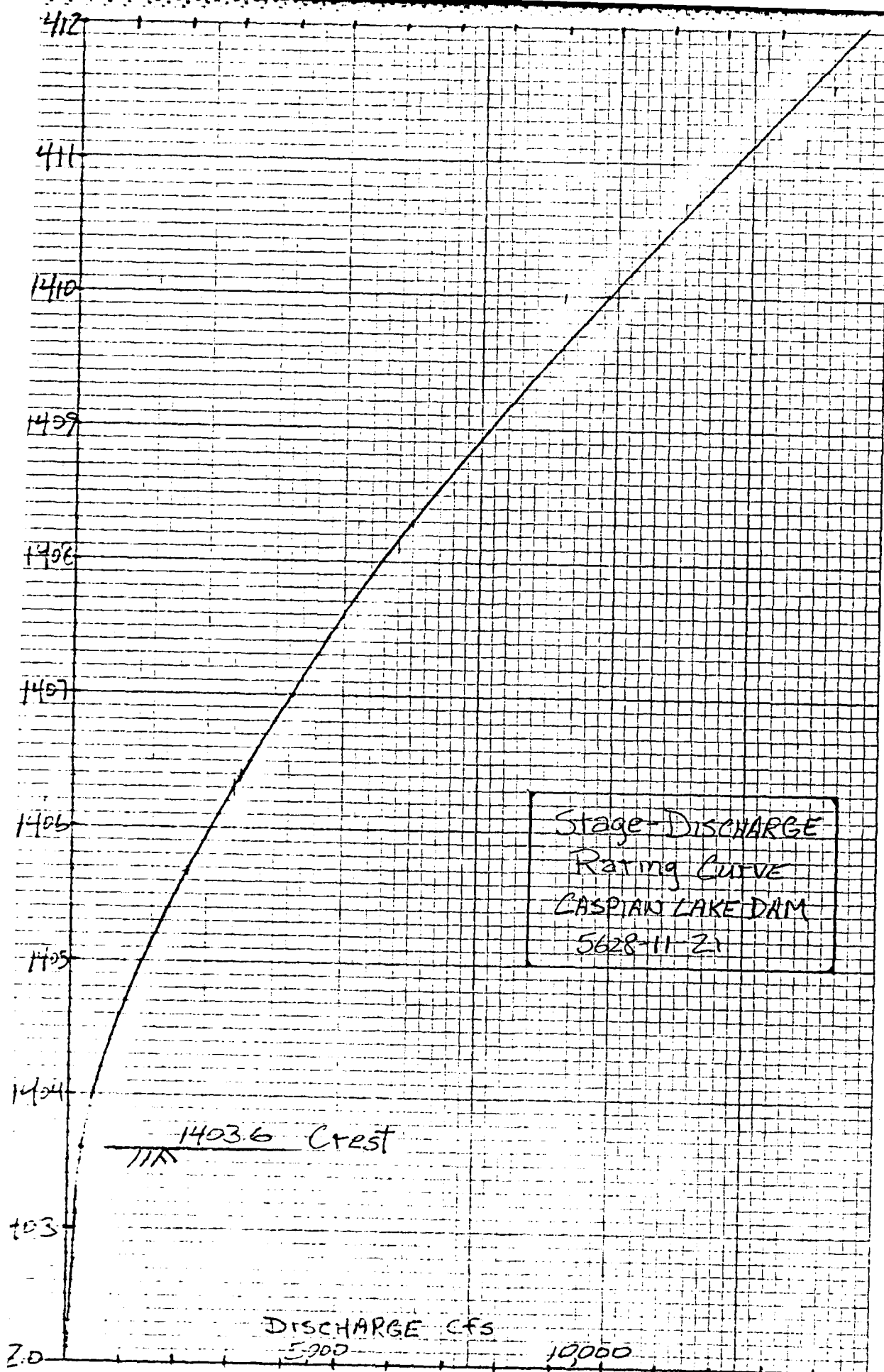

FIG. 1

Estimate of Downstream Damage

Reservoir Capacity

Normal Pool 2300. acre-ft elev. 1400.0
 Maximum Pool 4300. acre ft elev. 1402.75

Peak Failure Outflow

$$Q_{P1} = 8/27 \sqrt{g} w_b Y_0^{3/2}$$

$$w_b = 40\% \text{ of dam width} = (120.8 + 25) 40\% = 145.8 (4)$$

$$Y_0 = \text{height from stream bed to max pool elev.} \\ = 6.6 \text{ ft}$$

$$Q_{P1} = 8/27 \sqrt{g} (40)(145.8)(6.6)^{3/2} = 1662. \text{ cfs}$$

$$\underline{Q_{P1} = 1660 \text{ cfs}}$$

Stage-Discharge Curve

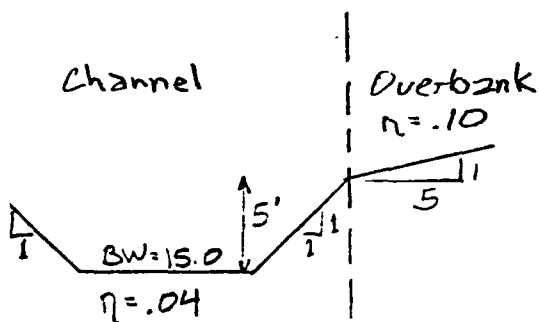

Reach Characteristics

$$L = 2600 \text{ ft}$$

$$S = 6.1\%$$

$$n = 0.04 \text{ channel} \\ n = 0.10 \text{ overbank}$$

see figure 2

Stage

Discharge.

Velocity

3.0 ft

860 cfs

16 fps

4.0

1410

19.

4.5

1730

20.

5.0

2093

21.

HNTB

HOWARD NEEDLES TAMMEN & BERGENDOFF

Made by RY

Date 11/21/78

Job No. 5628-11-21

Checked by WUPY

Date 1/16/79

Sheet No. 8

For Caspian Lake

Step 4. $Q_{P_1} = 1660 \text{ cfs}$ Stage₁ = 4.35 ft area₁ = 84.0'

L = 2600'

$$V_1 = \frac{84.0' \times 2600}{43,560} = 5.0 \text{ acre ft} < \frac{4300}{2}$$

Reel length OK

$$Q_{P_2 \text{ TRIAL}} = Q_{P_1} \left(1 - \frac{V_1}{5}\right) = 1660 \left(1 - \frac{5}{4300}\right) = 1658 \text{ cfs}$$

$$\text{Stage}_2 = 4.34 \text{ cfs} \quad \text{area}_2 = 83.9 \text{ '}$$

$$V_2 = \frac{83.9 \times 2600}{43,560} = 5.0 \text{ acre ft}$$

$$V_{AVE} = V_1 = V_2$$

$$Q_{P_1} = Q_{P_2}$$

Summary

1. If the Caspian Lake dam failed the resulting discharge would travel at a high velocity. however the maximum floodwave height of 4.35 ft would be for the most part be contained within the channel banks. Flows resulting from heavy rainfall would be of greater danger.

Stage-Discharge
ROUTING CURVE
GREENSBORO BROOK
CASPIAN LAKE
5628-11-21

Stage ft above streambed

11
10
9
8
7

1000 2000
Discharge cfs

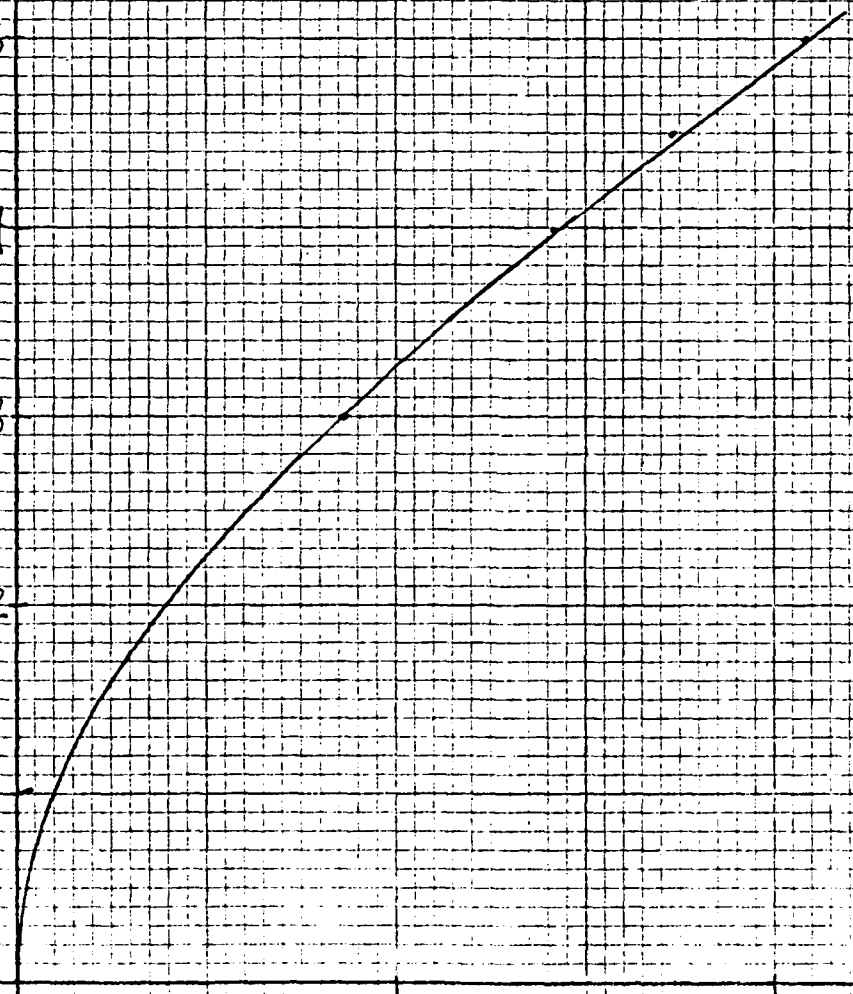

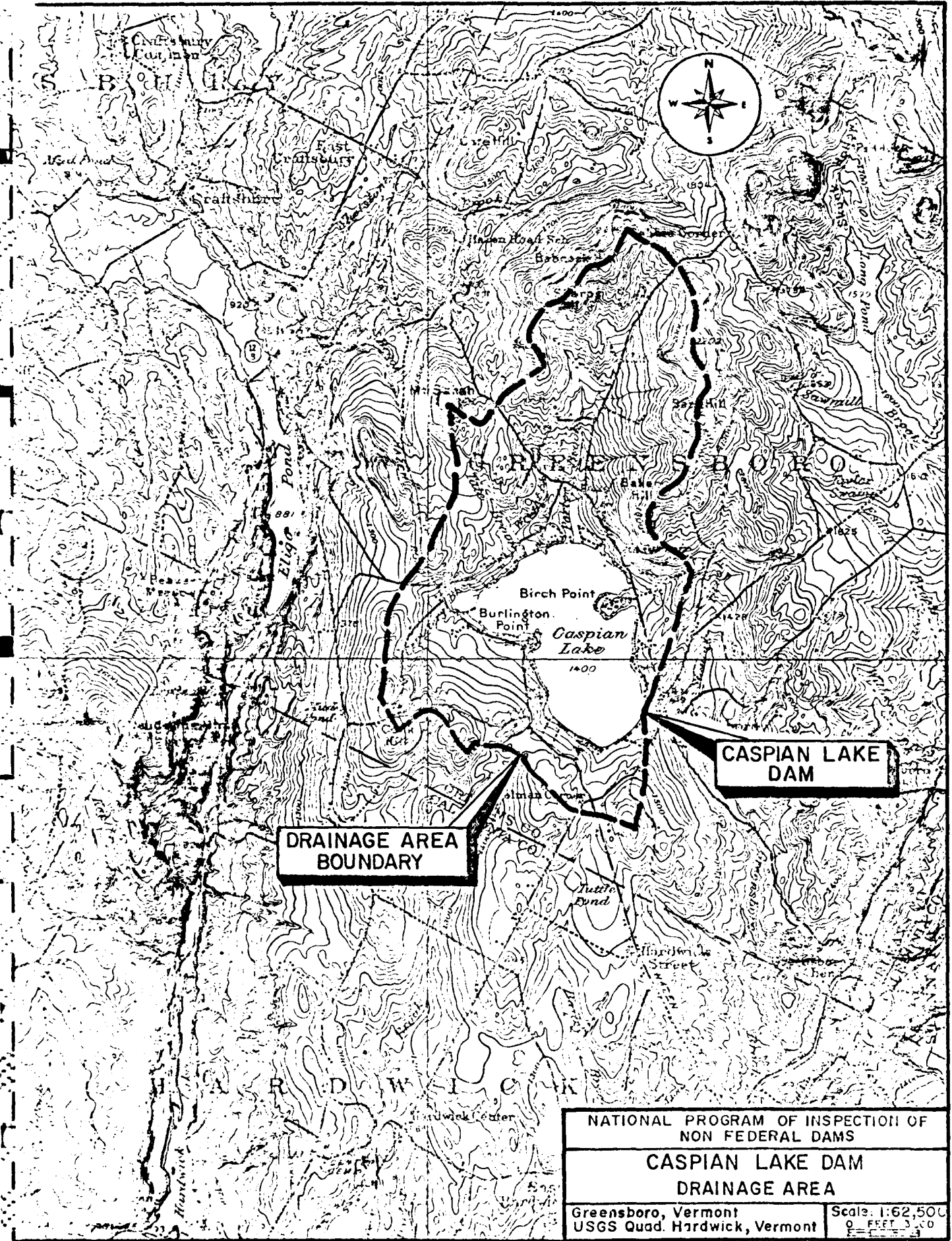

**DRAINAGE AREA
BOUNDARY**

**CASPIAN LAKE
DAM**

NATIONAL PROGRAM OF INSPECTION OF
NON FEDERAL DAMS

**CASPIAN LAKE DAM
DRAINAGE AREA**

Greensboro, Vermont Scale: 1:62,500
USGS Quad. Hardwick, Vermont 0 FEET 3.00

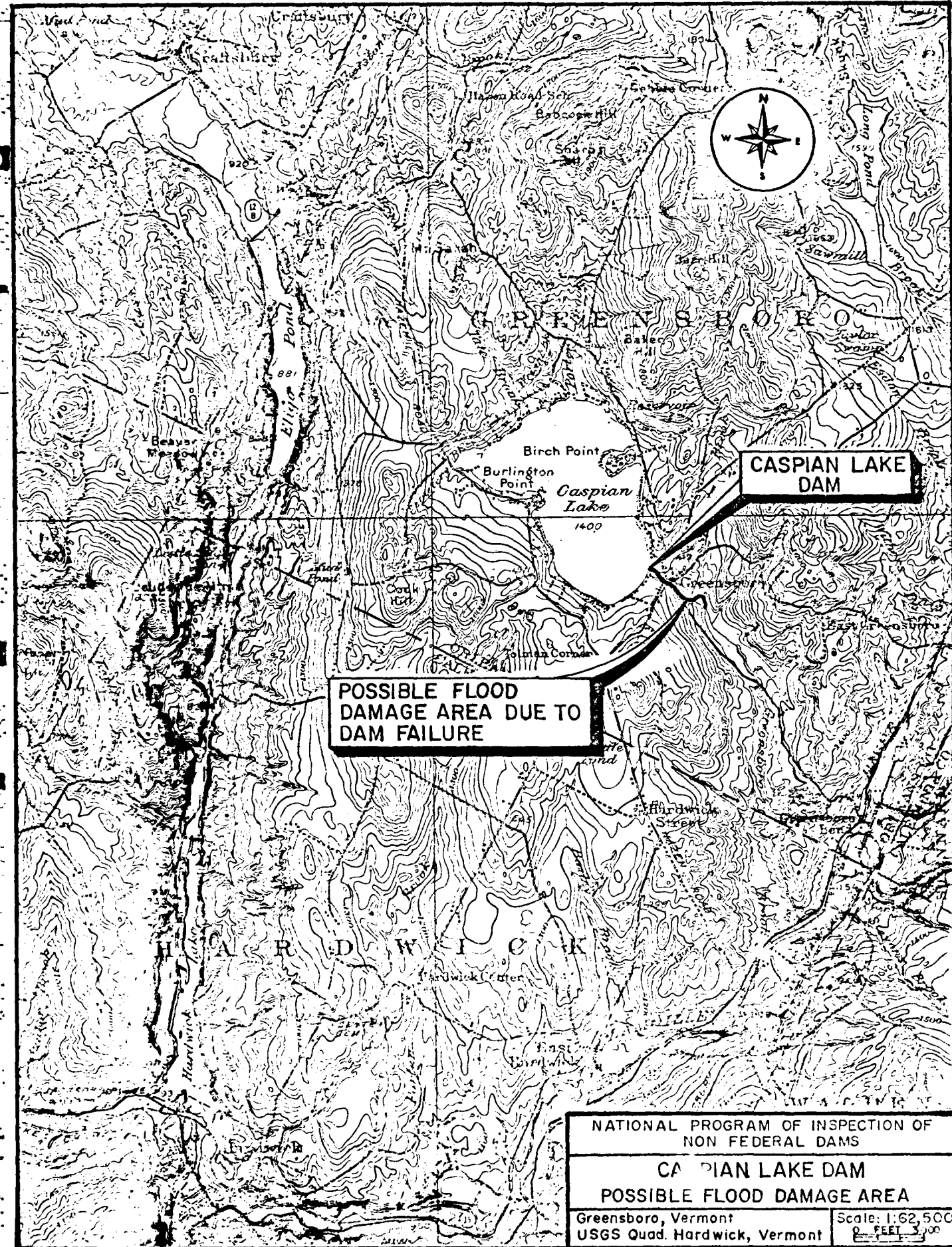

**POSSIBLE FLOOD
DAMAGE AREA DUE TO
DAM FAILURE**

**CASPIAN LAKE
DAM**

NATIONAL PROGRAM OF INSPECTION OF
NON FEDERAL DAMS

CASPIAN LAKE DAM

POSSIBLE FLOOD DAMAGE AREA

Greensboro, Vermont Scale: 1:62,500
USGS Quad. Hardwick, Vermont 0 FEET 3,000

APPENDIX E

INFORMATION AS CONTAINED IN
THE NATIONAL INVENTORY OF DAMS

END

FILMED

9-85

DTIC