

NATIONAL BUREAU OF STANDARDS  
MICROCOPY RESOLUTION TEST CHART

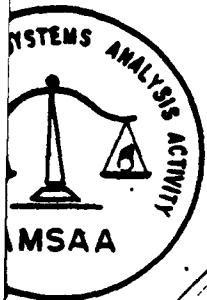

AD-  
TECHNICAL REPORT  
USAIRO-TR-84/4

2

AMSAA

AD-A157 677

**THE COOPERATIVE ASSIGNMENT OF  
REQUIREMENTS FOR AUTOMATIC  
MULTIPURPOSE TEST EQUIPMENT BY  
LOCATION (CAMEL)**

**INVENTORY  
RESEARCH  
OFFICE**

**Donald A. Orr**

**April 1984**

**DTIC  
ELECTE  
AUG 07 1985**  
**S D**  
**E**

This document has been approved  
for public release and sale; its  
distribution is unlimited.

US Army Inventory Research Office  
US Army Materiel Systems Analysis Activity  
800 Custom House, 2d & Chestnut Sts.  
Philadelphia, PA 19106

85 8 1 097

DTIC FILE COPY

Information and data contained in this document are based on the input available at the time of preparation. The results may be subject to change and should not be construed as representing the AMC position unless so specified.

~~UNCLASSIFIED~~

SECURITY CLASSIFICATION OF THIS PAGE (When Data Entered)

REPORT DOCUMENTATION PAGE		READ INSTRUCTIONS BEFORE COMPLETING FORM
1. REPORT NUMBER	2. GOVT ACCESSION NO.	3. RECIPIENT'S CATALOG NUMBER
	AD-A157 677	
4. TITLE (and Subtitle) THE COOPERATIVE ASSIGNMENT OF REQUIREMENTS FOR AUTOMATIC MULTIPURPOSE TEST EQUIPMENT BY LOCATION (CAMEL)	5. TYPE OF REPORT & PERIOD COVERED Technical Report	6. PERFORMING ORG. REPORT NUMBER
7. AUTHOR(s) DONALD A. ORR	8. CONTRACT OR GRANT NUMBER(s)	
9. PERFORMING ORGANIZATION NAME AND ADDRESS US Army Inventory Research Office Room 800, US Custom House, 2nd & Chestnut Sts. Philadelphia, PA 19106	10. PROGRAM ELEMENT, PROJECT, TASK AREA & WORK UNIT NUMBERS	
11. CONTROLLING OFFICE NAME AND ADDRESS US Army Materiel Development & Readiness Command 5001 Eisenhower Avenue Alexandria, VA 22333	12. REPORT DATE April 1984	13. NUMBER OF PAGES 48
14. MONITORING AGENCY NAME & ADDRESS (if different from Controlling Office) US Army Materiel Systems Analysis Activity Aberdeen Proving Ground, MD 21005	15. SECURITY CLASS. (of this report) UNCLASSIFIED	15a. DECLASSIFICATION/DOWNGRADING SCHEDULE
16. DISTRIBUTION STATEMENT (of this Report) Approved for Public Release; Distribution Unlimited		
17. DISTRIBUTION STATEMENT (of the abstract entered in Block 20, if different from Report)		
18. SUPPLEMENTARY NOTES		
19. KEY WORDS (Continue on reverse side if necessary and identify by block number) Multipurpose Test Equipment Optimal Allocation Level of Repair Analysis (LORA) Modelling		
20. ABSTRACT (Continue on reverse side if necessary and identify by block number) For the repair of modules and components that have failed, one alternative is to invest in multipurpose automatic test equipments (ATE). These expensive, general purpose systems are designed to perform many tests for fault detection, isolation, and diagnostics over a wide range of possibly failed assemblies, which may have been pulled from various weapon systems or end items. If bought these ATE's would form a necessary part of the repair process at a maintenance echelon.		

UNCLASSIFIED

UNCLASSIFIED

SECURITY CLASSIFICATION OF THIS PAGE(When Data Entered)

**ABSTRACT (CONT)**

There are several implicit decisions that, in the consideration of this maintenance philosophy, have to be made. Among these are:

- a. Which components and modules of a particular weapon system should be repaired using the ATE concept?
- b. For those components/modules that are candidates to be repaired using ATE, where should the test and repair be done?
- c. Across many weapon systems, what is the workload requirement on the ATE's to test and repair failed assemblies?
- d. Where should the ATE's be placed to best fit, in an economic manner, the needs of the many users?

Rational ways to reach these and other decisions are discussed.

UNCLASSIFIED

SECURITY CLASSIFICATION OF THIS PAGE(When Data Entered)

ACKNOWLEDGEMENT

The author wishes to thank the Graphics Department at Aberdeen, who improved his original hand-drawn figures and did so in an expeditious manner.

Accession For	
NTIS GRA&I	<input checked="" type="checkbox"/>
DTIC TAB	<input type="checkbox"/>
Unannounced	<input type="checkbox"/>
Justification	
By _____	
Distribution/ _____	
Availability Codes	
Dist	Avail and/or Special
A-1	



## CONTENTS

	Page
ACKNOWLEDGEMENT.....	3
TABLE OF CONTENTS.....	5
1. THE OVERALL PROBLEM.....	7
2. THE LOCAL PROBLEM.....	11
3. THE CENTRAL PROBLEM.....	15
4. THE MODEL.....	19
5. THE SOLUTION - AN EXAMPLE.....	21
6. THE COOPERATION PROBLEM.....	25
6.1 General.....	25
6.2 Outline of Cooperative Procedure.....	27
7. THE DYNAMIC PROBLEM.....	29
BIBLIOGRAPHY.....	31
APPENDICES	
A POTENTIAL DECREASE IN NUMBER OF ATEs USING CAMEL (CENTRALIZED DECISION).....	33
B SETUP OF APEX II RUN.....	37
C SUMMARY OF ORLA MODELS.....	41
D GLOSSARY OF ACRONYMS AND TERMS.....	47
DISTRIBUTION.....	49

THE COOPERATIVE ASSIGNMENT OF REQUIREMENTS FOR AUTOMATIC  
MULTIPURPOSE TEST EQUIPMENT BY LOCATION (CAMEL)

Chapter 1. THE OVERALL PROBLEM

For the repair of modules and components that have failed, one alternative is to invest in multipurpose automatic test equipments (ATE). These expensive, general purpose systems are designed to perform many tests for fault detection, isolation, and diagnostics over a wide range of possibly failed assemblies, which may have been pulled from various weapon systems or end items. If bought, these ATE's would form a necessary part of the repair process at a maintenance echelon.

There are several implicit decisions that, in the consideration of this maintenance philosophy, have to be made. Among these are:

a. Which components and modules of a particular weapon system should be repaired using the ATE concept? Alternatives would be to throw the assembly away or use dedicated special test equipment (STE) in the repair process.

b. On a weapon system, for those components/modules that are candidates to be repaired using ATE, where (at what maintenance echelon) should the test and repair be done?

c. Across many weapon systems and end items, what is the workload requirement on the ATE's to test and repair failed assemblies?

d. Where should the ATE's be placed to best fit, in an economic manner, the needs of the many users?

e. How will the need for ATE's change in the future and where do they go?

f. What information is needed and how is it to be used to reach the preceding decisions?

The answers to these questions and rational ways to reach these decisions will be discussed in the following sections and they will be addressed in an Army maintenance environment. Repair can be effected at four levels: organizational (ORG), direct support (DSU), general support (GSU), and depot. End item repair (usually by replacement of a component) would typically be done at ORG/DSU. Component repair might be done at DSU or above, but if it is a candidate for use on a multipurpose ATE, the decision would probably be between GSU and depot. Since the costs of general purpose ATE's are high, it is hard to find studies that could justify placing them at the many support

units below general support level. Although the model herein is written and explained for GSU/Depot decisions, there is nothing to preclude its consideration of other echelons for placement. The diagram, Figure 1, reflects this environment, with assemblies, which are managed by several distinct Commodity Commands, being pulled off the basic types of end items - planes, tanks, trucks, artillery, missiles, communication equipments - and sent to a higher level for repair. Each different component type requires, at the site of the ATE, its own test program set (TPS) and interconnect device (ICD); the TPS is software (a tape) which contains the unique logic which allows the ATE to diagnose the particular component currently connected to it.

In Chapter 2, the issues related to question (a) are considered under the sobriquet "The Local Problem." Questions (c) and (d) are addressed in Chapter 3 as part of "the Centralized Problem." Question (b), it will be found, is part of the local problem, and is also of concern to the Centralized Decision Maker. Chapter 6, "The Cooperative Problem," is concerned with answering question (f) within the current Army organizational structure; and attempts at resolving question (e) are found in Chapter 7, "The Dynamic Problem."

Finally, in the middle of the report, Chapters 4 and 5 are the model formulation and solution with example. The model, called CAMEL, is a tool for the Centralized Decision Maker which allows ATE allocation across space and time in a manner which in some sense is beneficial across all Commodity Commands. What makes the decision interesting is that it may not be individually optimal to the local users (the weapon system managers). However, the model will require all agencies concerned to provide the proper flow of information and local decisions.

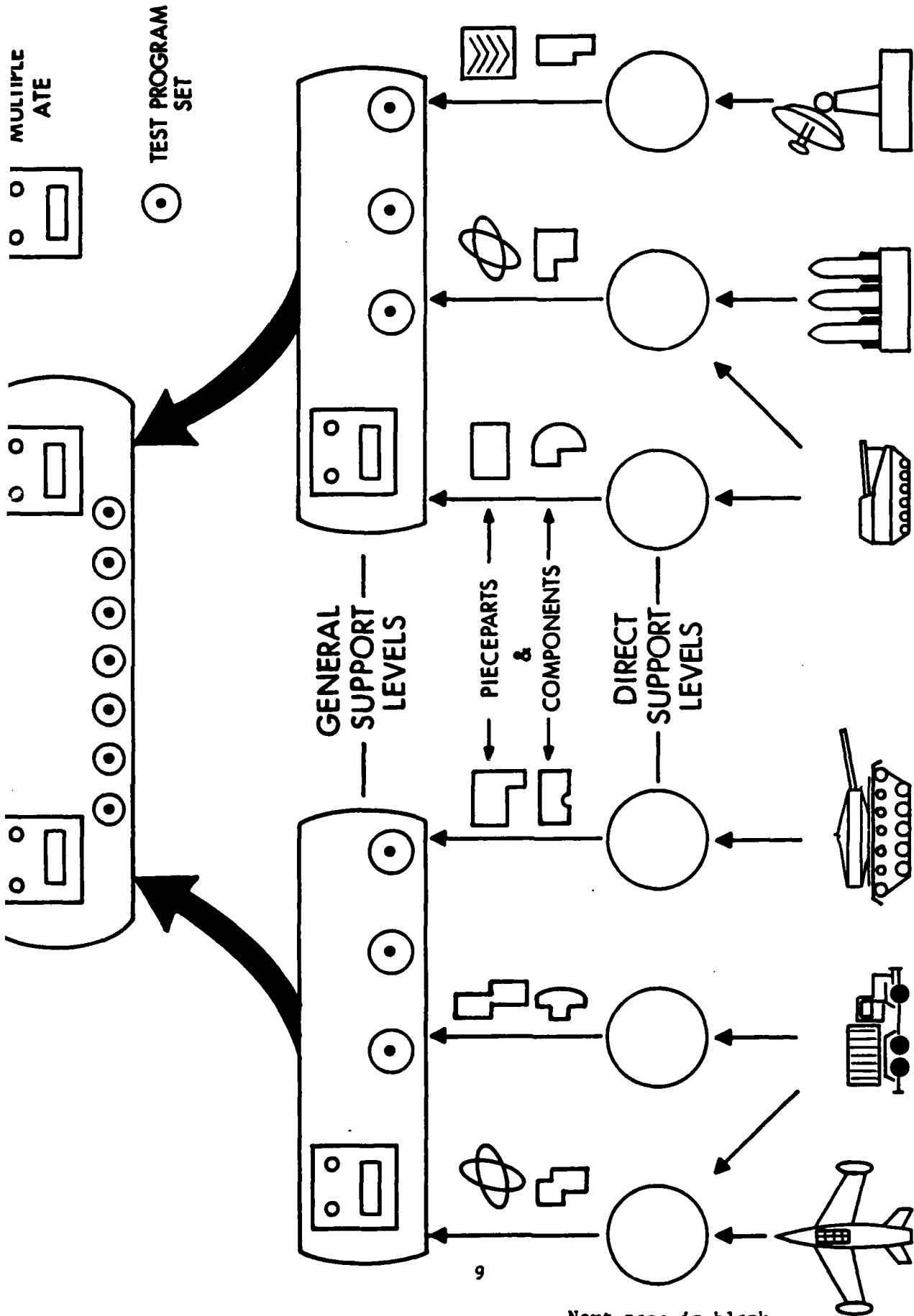

Next page is blank

Figure 1. Multiechelon Support Environment.

## Chapter 2. THE LOCAL PROBLEM

The Local Problem is this: those responsible (e.g. a system manager) for the development, logistic support and maintenance of an end item should be concerned about how and where to repair it and its constituent assemblies. Decisions have to be made on what types of test equipment should be used to assist in repairing the weapon system/end item, and components and modules (indentured in component) of the system. If special test equipments (STE), specifically designed and built to test this system and these assemblies are to be used, one must decide how many (in integer amounts) are needed and in what maintenance support locations to place them. If some of the repair is to be accomplished by sharing time on common test equipment (i.e. multipurpose ATE's using TPS's), the local decision maker must determine how much time (based on expected component failures, and expected times hooked to ATEs) his system will expend of the ATEs' available time. This requirement can be expressed in fractional units of the ATEs per year per some standard density of the weapon system in question. The local decision maker would also indicate where he would prefer doing repair on specific components (e.g. GSU, depot) by breaking out these fractional ATE's by echelon.

All of the above questions can (or should) be answered by Level of Repair Analysis (LORA) models. There are several of these models accessible to the Army User [2, 3, 4, 5]. Appendix C gives summary explanations of some of the models in use. Many of the LORA models are what may be termed evaluators, i.e. the models evaluate the cost and/or performance implications of a modest number of maintenance policies. (A policy typically is: repair end item at ORG, repair line replaceable units (LRU) at DSU, repair module at Depot, throw away parts). Some "best" policy is then chosen.

A subset of LORA's are the true optimizers (Optimal Repair Level Analysis Models - ORLA's). These models find the optimal policy for each component & module, usually by employing some heuristic search rather than complete enumeration. (Note that the number of combination policies which specify decisions on every assembly can be quite large.). A recently developed ORLA for use by the Army is the OATMEAL model [2].

Figure 2 indicates the attributes of an ideal ORLA. At the top arrows indicate important input categories; stacks of test equipment alternatives for each of the LRU's and other components/modules which might contain ATE's, different STEs, or test/repair by special repairmen (MOS) only; for LRU's

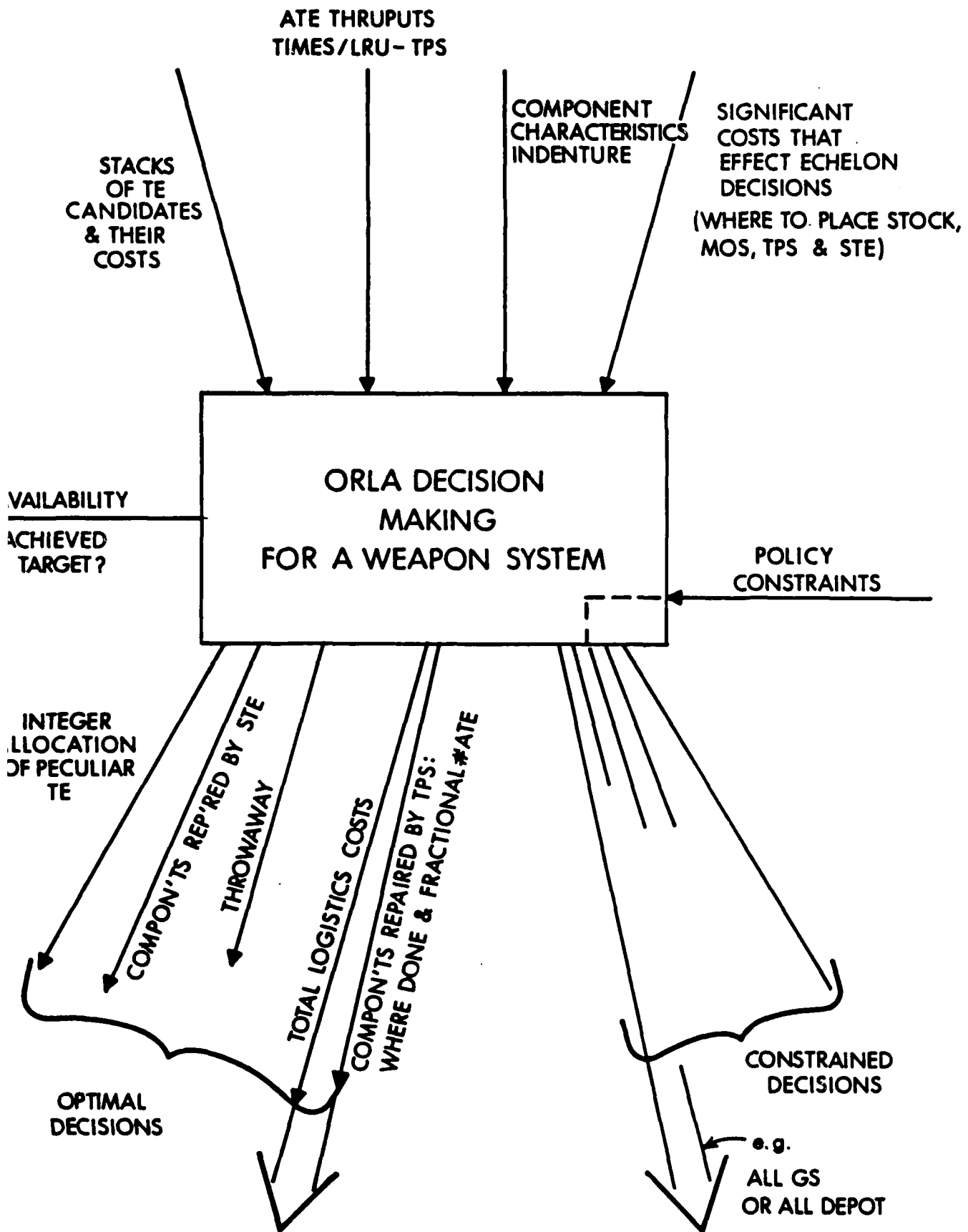

Figure 2. An Ideal ORLA Model.

using the TPS/ATE concept one must know their individual connect times (ATE "thruput"). It is desirable that the ORLA can guarantee an operational availability target by a combination of effective maintenance policies and optimal allocation of stockage by echelon. The ORLA should have the capability of generating optimal decisions (assemblies' repair decisions, allocation of STE and fractional requirements on ATE's) and the costs thereof; the model should also be able to operate in a constrained mode, where external considerations constrain repair or TE placement to certain levels.

The OATMEAL model has all these attributes.

Some of the outputs (in optimal or constrained modes) from these individual LORAs/ORLAs will be seen to be important to a Centralized Decision Maker (CDM) in considering the Central Problem. Hence some standardization/definition of local costs and ATE requirements will be necessary.

## Chapter 7. THE DYNAMIC PROBLEM

The problem considered in this technical report is a dynamic one. There are the dynamics of queueing at the ATEs (which we do not consider, but rather compute expected value requirements or workload) and there are the dynamically changing requirements as end item densities change and new weapon systems are planned to be deployed, thereby expanding the ATE base.

For the latter aspect we propose setting up the model periodically to run cumulative requirements over the expanding planning horizon. Any previous decisions on ATE purchases and allocation which are irrevocable because they have already been placed at fixed sites in the field are handled in the run by initialization constraints on the  $T_D$  and  $T_G$  variables, i.e. add extra rows to the integer LP.

$$T0_D - T_D \leq 0$$

$$T0_{G_i} - T_G \leq 0$$

where  $T0_D$  is number of ATE already at depot

$T0_{G_i}$  is number of ATE already at site  $i$ .

In this way any solution for the new cumulative requirements will not be in conflict with existing placements, and the implementation reaction to the solution would be to plan on buying the differences  $T_D - T0_D$ ,  $T_{G_i} - T0_{G_i}$ . The year by year purchases can be planned in this manner, by setting up the model yearly with updated data from the local users and with the numbers for past purchases.

## II MACRO Workloading - Piecemeal Approach

1. Each WSS manager will apply the ORLA procedure of I.
  - a. For those TMDE peculiar to a WSS, the requirement by level as determined in I.3.b. will be the MACRO workload.
  - b. When a concept is chosen that requires a common TMDE across WSS, or in the case of EQUATE, TPS's are chosen that are run on a common ATE, the levels (GS or depot) chosen by TPS by LRU and the fractional ATE requirement when using those TPS's are submitted to the ATE manager.
2. The ATE manager applies a rollup program (which may modify the fractional ATE requirement based on echelon and ATE/TPS factors) to find the total ATE at GS and depot across WSS. The ATE requirement at a particular GS will depend upon the deployment program of WSS that are being supported by that GS in that geographical area.
3. The ATF manager may modify manually the totals by GS and Depot to shift fractions to integer number of ATE's at each GS & Depot. He will advise the WSS manager of such shifts of GS and Depot resources in case they wish to shift their repair policies on LRU's (and hence TPS requirements).

## III MACRO Workloading - Decision Making Using an Aggregate Model

1. As in the II.1.b. Also include the logistics costs of the optimum policy and of the GS and DS alternatives for the components in the WSS that use TPS.
2. The Mathematical Program Model Caramel is used.
  - a. Use the inputs from (1).
  - b. Apply cost tradeoffs to allocate integer amounts of ATE's (EQUATES) to GS and Depot levels that satisfy MACRO workload and individual GS area constraints.
3. Advise WSS managers of EQUATE allocation scheme as in II.3.
4. As more WSS (types and quantity) are deployed that will require TPSs and EQUATES, the allocation model can be rerun. Or if mobility constraints and previous WSS repair policies make this infeasible, the allocation to GS, Depot will be made only for the additional number of new EQUATES needed.

6.2 Outline of Cooperative Procedure.

I LORA Procedure - WSS Peculiar

Development State  
of WSS

- 1.a. Establish developmental costs for TPS/ATE. Estimate thrupt capability on the ATE (EQUATE) for the TPS needed.
- b. Establish developmental costs and thrupt values for alternative TMDE to TPS/EQUATE concept.
- c. Run a simple ORLA (e.g. Kasian), or a sophisticated ORLA with soft data to establish by LRU the economics of the decisions:
  - TPS
  - Prescreening with TPS
  - Throwaway
  - TMDE Alternative

Advanced Development;  
TPS Economics Stage

Project budget requirement of chosen decision.

- 2.a. Establish support costs (e.g. using SESAME) for TPS, its adaptors, connecting devices, etc. Improve thrupt values on the ATE.
- b. Establish support costs and better thrupt values (micro workload formulae) for the alternative TMDE.
- 3.a. Run a "sophisticated ORLA" using the TPS concept. Run a "sophisticated ORLA" using alternative TMDE concept, if that is still a candidate based on the economics and the availability of such alternative hardware.
- b. Choose the concept and establish the repair policies by LRU, SRU and the TE allocations by support level as indicated by the ORLA output. If TPS/EQUATE chosen, retain the workload requirements (fractional ATE) for this WSS on the EQUATE and the logistical costs for GS & DS alternatives.
- 4. Iterate (3) based on manager feedback and also based on any MACRO workloading and allocation decisions on the EQUATE.

Engineering Development;  
Task Requirements &  
Design Stages on TPS,  
TMDE

Engineering Development

overall problem is a "MEGA" ORLA run by a central decision maker to make the repair decisions and TMDE requirements for all weapon systems jointly considered. This just is not feasible due to the data requirements and timing problems, not to mention the mathematical problems due to size and complexity.

As an initial step in coordination, the CDM should provide accurate timely data and formulae concerning the characteristics of the ATE to the local users so that they may determine accurate "fractional" workload values for the ATE on their systems. The LDM's should optimize in formulating maintenance and supply policy to the extent possible under local policy constraints. The OATMEAL model is recommended as a standard. The logistics costs submitted should include all significant system related costs in maintenance, supply, transportation - exclusive of the shared ATE costs, pro rata or not - that impact the local policy decisions. The costs should be present value; this concept makes commensurate costs that are entering the time stream at different points for the LDM and also across weapon systems which shall be incurring costs at different times and establishing ATE requirements at different times. The CDM must use this input to set up the allocation model with values related to requirements over a certain planning horizon. Certainly this program should be rerun periodically for that horizon, and local managers should continually submit updated figures based on any changes in data or plans for their systems' support. Secondly the model must be set up and rerun as the planning horizon expands and more weapon systems are seen to be deploying and needing ATE support.

More about this dynamic problem in the next chapter, but first a procedural outline addressing cooperation and coordination.

## Chapter 6. THE COOPERATION PROBLEM

### 6.1 General.

The Local Decision Makers (LDM) (those involved in logistic support analysis of deploying weapon systems) and the Centralized Decision Maker (the responsible manager of shared resources - in this case ATEs) have to agree to cooperate and then coordinate data, information flow, and decision making.

The interesting philosophical portion of this chapter's problem is the agreement to cooperate. If in truth the LDM's have expended effort, used a rational process, and have decided on repair policies that are, in some sense, optimal to them, they have a vested interest and are naturally reluctant to follow some policy made by a CDM which meets some higher goal (re Chapter 4 the minimization of all WSS logistics costs plus costs of ATE placements). Of course if the LDM's do not adjust their local policies, the cooperation can be by coercion, i.e. the CDM makes his placement of ATEs and this fait accompli would leave the local users no choice but to send unserviceables to where the ATE's are located.

So assuming a form of cooperation exists in terms of policy adjustments, why should the LDM's perform analyses of such quality obtainable from the ideal ORLA's mentioned in Chapter 2? Because the closer the local policy found is to a true optimum, the greater likelihood that that policy's logistics costs are significantly lower than the costs associated with all Depot or all GSU repair. And if all LDMs submit these kind of costs, the cost advantages of the local optima might make the CDM's decision on ATE placement closer to local preferences re allocation.

As part of the CDM-LDM linkage, feedback of CDM decisions should be utilized. This was briefly mentioned in Chapter 3. If ATE's have not been placed (or not enough of them) in areas a LDM preferred, he may wish to rerun his ORLA with constraints on repair in this area or rerun in order to ascertain if STE becomes a viable alternative to ATE. Conversely if the LDM becomes aware that an ATE has been placed in an area accessible to him based on other systems' preferences and there is still "space" on that ATE, he may wish to reanalyze and drop any previous decisions to use dedicated STE in favor of the ATE.

It should be mentioned here that instead of feedback, cooperation, and individual, local use of ORLA's, the ultimate, optimal solution to the

The results are shown for the four policies of interest: the decentralized policy based on local WSS decisions, placing all ATE at depot, placing ATE's at GSU areas only, and the CAMEL centralized solution. Closer inspection of the last allocation shows that the optimal policy on WSS 3 was not altered; nevertheless all five managers should be advised that no ATE's would be available in GSU areas 1 and 3 and that they should be prepared for overloading in area 2 if they don't shift some of their repair upwards.

Appendix B presents the setup of this example for the Apex II Integer Linear Program package.

TABLE 1. SAMPLE PROBLEM

WSS	FRACT ATE	FD	FG	LC <sup>#</sup>	LC <sub>D</sub>	LC <sub>G</sub>	AREAS (GS)		
							1	2	3
1	1.1	.5	.6	3	3.2	3.3	✓	✓	✓
2	.5	.2	.3	2	2.15	2.05		✓	✓
3	1.2	.7	1.5	4	4.3	4.1		✓	
4	.6	.4	.2	5	5.3	5.5	✓		✓
5	1.0	1		3.5	3.5	3.9	✓	✓	✓

CEQ  
= 2

**RESULTS**

POLICY	ATE ALLOCATION				ATE COST	LOG COST	TOTAL COST
	D	1	2	3			
WSS ORLAs	3	1	1	1	12	17.5	29.5
ALL DEPOT	5				10	18.45	28.45
ALL GSU		1	3	2	12	18.85	30.85
CAMEL	4		1		10	18.15	28.15

Chapter 5. THE SOLUTION - AN EXAMPLE

A sample problem for five weapons systems and four potential sites for ATEs (3 GSU areas and 1 depot) is set up in Table 1 and the results given also. Note that the FD and FG columns for breakouts of the fractional ATE requirements represent the "preferred" local breakout of Depot and GSU levels. We assume, in this problem, that the FG is equally divided among the area GSU's the WSS is being deployed to. The equations then become:

$$D : \quad 1.1 a_{D_1} + .5a_1^* + .5 a_{D_2} + .2 a_2^* + 1.2 a_{D_3} + .7 a_3^* \\ + .6 a_{D_4} + .4 a_4^* + 1.0 a_{D_5} + 1.0 a_5^* - T_D \leq 0$$

$$A1 : \quad \frac{1.1}{3} a_{G_1} + \frac{.6}{3} a_1^* \\ + \frac{.6}{2} a_{G_4} + \frac{.2}{2} a_4^* + \frac{1.0}{3} a_{G_5} \quad - TG_1 \leq 0$$

$$A2 : \quad \frac{1.1}{3} a_{G_1} + \frac{.6}{3} a_1^* + \frac{.5}{2} a_{G_2} + \frac{.3}{2} a_2^* + 1.2 a_{G_3} + .5 a_3^* \\ + \frac{1.0}{3} a_{G_5} \quad - TG_2 \leq 0$$

$$A3 : \quad \frac{1.1}{3} a_{G_1} + \frac{.6}{3} a_1^* + \frac{.5}{2} a_{G_3} + \frac{.3}{2} a_2^* \\ + \frac{.6}{2} a_{G_4} + \frac{.2}{2} a_4^* + \frac{1.0}{3} a_{G_5} \quad - TG_3 \leq 0$$

$$\text{MIN } \left\{ \begin{array}{l} 2 \cdot (T_D + TG_1 + TG_2 + TG_3) + 3.2 a_{D_1} + 3.3 a_{G_1} + 3 a_1^* + \text{etc.} \\ \uparrow \\ \text{CEQ} \end{array} \right.$$

We also have 5 equations of the form  $a_{D_i} + a_{G_i} + a_i^* = 1$

Let

- FD(i) = fractional # ATE at depot for WS i  
FG(i) = fractional # ATE at GS for WS i  
LC\*(i) = optimal logistics cost for the above allocation;  
a\*(i) is a variable denoting this decision for system i  
LC<sub>DEP</sub>(i) = cost under depot use only; associated variable a<sub>D</sub>(i)  
LC<sub>GS</sub>(i) = cost under GS use only; associated variable a<sub>G</sub>(i)  
C<sub>EQ</sub> = cost of one equate (ATE)

#### Decision Variables

T<sub>D</sub>, T<sub>G</sub> = integer # of ATE at depot, GS

a\*(i)  
a<sub>D</sub>(i)  
a<sub>G</sub>(i)

} 0 - 1 "alternative" variables

Constraints: (Integer ATE's are sufficient for aggregate fractional requirements)

$$\sum_i [\text{FD}(i) + \text{FG}(i)] a_D(i) + \text{FD}(i) a^*(i) - T_D \leq 0$$

$$\sum_i [\text{FD}(i) + \text{FG}(i)] a_G(i) + \text{FG}(i) a^*(i) - T_G \leq 0$$

$$\text{for each } i : a_D(i) + a_G(i) + a^*(i) = 1$$

#### Objective Function

Minimize

$$C_{EQ}(T_D + T_G) + \sum_i LC^*(i) \cdot a^*(i) + LC_{DEP}(i) \cdot a_D(i) + LC_{GS}(i) \cdot a_G(i)$$

## Chapter 4. THE MODEL

The formulation of the CAMEL model for allocation of an ATE type of equipment (e.g. the EQUATE system) is on the next page. The integer linear program (LP) model is given in a simple form - for a depot level and one general GSU level; later some enhancements shall be illustrated, such as GSU constraints when N deployment areas are considered and additional constraints when some ATE's have already been fielded or fixed at some locations.

In the integer LP, for each system  $i$ , only one of the alternative variables, "a", is set equal to one, the others are zero. The constraints insure that, under any combination of these "a" settings, the aggregate fractional requirements  $FD$ ,  $FG$  will be less than the chosen integer values of  $T_D$  and  $T_G$ . The objective function is chosen so that  $T_D$ ,  $T_G$  and "a" values will minimize total acquisition costs of the ATE's plus logistics costs across the weapon systems.

Some mention should be made of CAMEL's sub-optimality. The optimal formulation would be to allow the CDM to evaluate all possible combinations of distributions of ATE to echelons for all WSS; this, in effect, requires a "MEGA-ORLA" which considers all WSS's and their costs and searches for a global solution. Taking the ORLA responsibility out of the hands of the local DM is not feasible for many practical reasons. In Appendix A it is shown that CAMEL's potential savings is close to that of a global optimum.

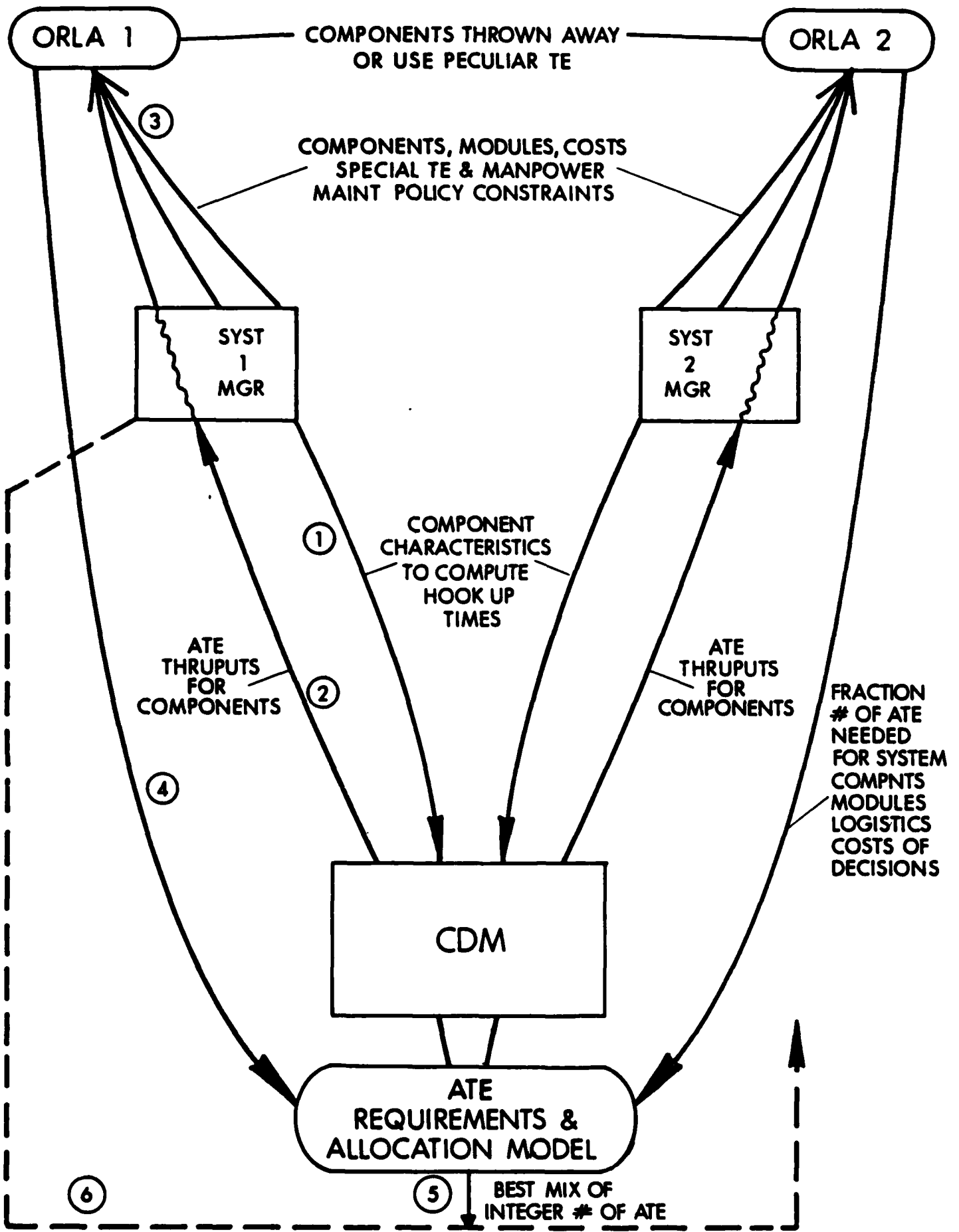

Figure 4. An Ideal Flow of Information.

Step 1. Each manager (system 1 and system 2) sends characteristics (e.g. hybrid, digital or analog circuitry) of candidate components to CDM so he can use connect time formulae to compute ATE thruputs for each candidate. As mentioned before this calculation could be done locally.

Step 2. Send ATE thrupt values to local users for use in ORLA decision making.

Step 3. Local managers provide other information (costs, failure rates, special test equipment (STE) alternatives, manpower skills (MOS)) necessary to make repair policy decisions. These decisions will include what components are not ATE/TPS candidates (thrown away or use STE) and hence which should be. It is desirable that ORLA 1 and ORLA 2 be a standard model, or at least output logistics costs that are commensurate.

Step 4. Essential outputs from the ORLA's shall be fed to the CDM. These include logistics costs of several decisions: preferred or optimal repair levels when using ATE's, repair only at GSU, repair only at DEPOT. Fractional numbers of ATE's are also required.

Step 5. The CDM has responsibility for pooling this local data from Step 4 into an ATE requirements and Allocation Model. The CAMEL model of Chapters 4 and 5 is recommended.

Step 6. Any decisions on ATE allocation from Step 5 which may impact particular local users should be fed back to them. For example they should be advised that there might be some queueing at GSU under their repair policy since there has been a decision to consolidate some GSU ATE workload at depot.

An outline of a procedure for developing the ATE requirements is given in Chapter 6, where the necessary cooperation between the ORLA users and the CDM is emphasized. But first we shall devote some chapters to the mathematical details of the CAMEL model which the CDM would use to optimally allocate ATE's.

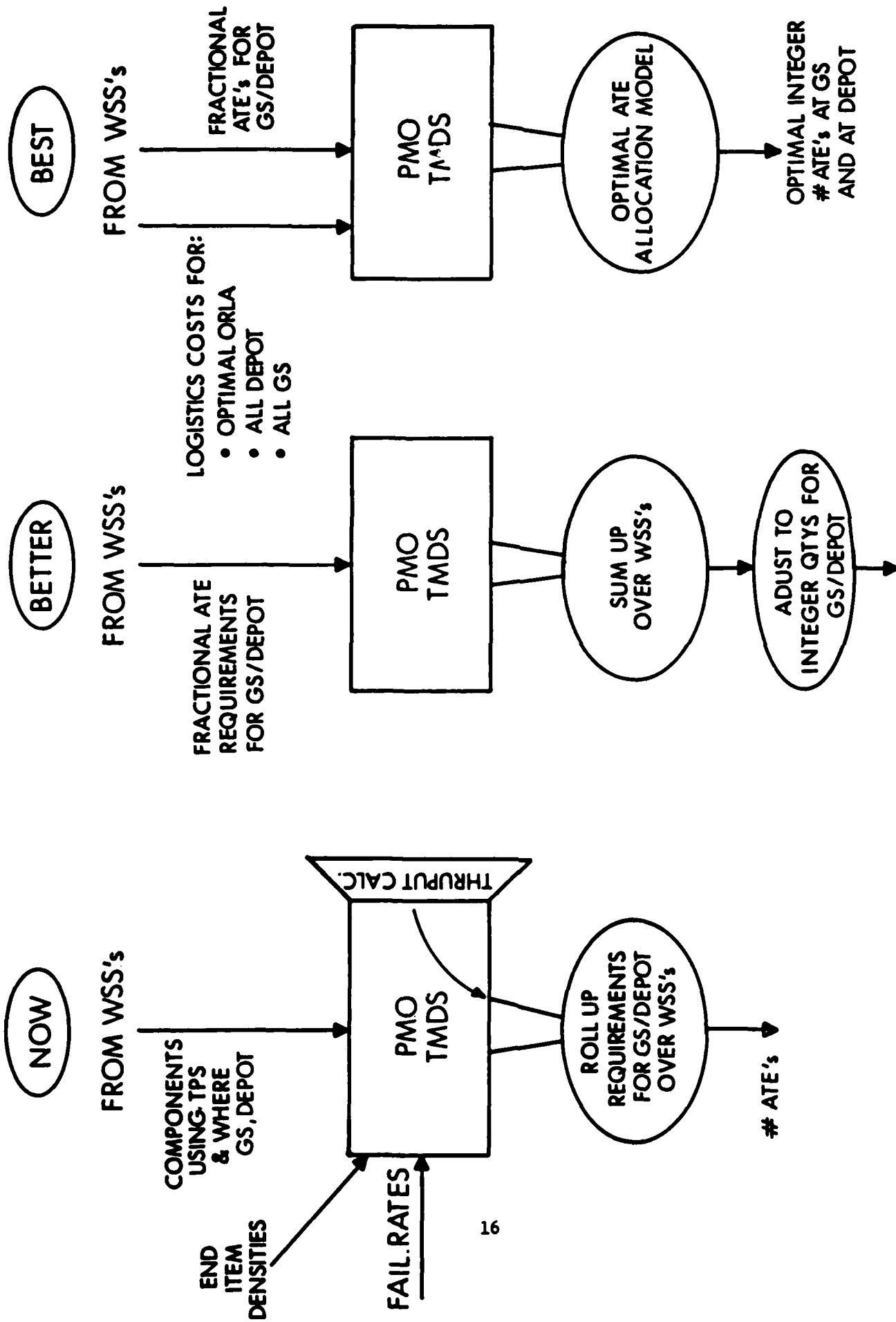

Figure 3. Approaches to Central Problem.

### Chapter 3. THE CENTRAL PROBLEM

The question of how many of a type of ATE (for example the Army's EQUATE system) are required to support many users (managers of weapon systems) can be answered by a centralized decision maker (CDM) and it can be done systematically or haphazardly. In theory the CDM is in a position to gather information from local sources, consolidate same, and utilize some procedure for rolling up and allocating requirements.

The CDM can use the data from the individual weapon systems (WSS's) or obtain similar data from other sources. Currently (see NOW portion of Figure 3) the CDM (In this figure, the Project Manager Office of Test, Maintenance, Diagnostics Systems) obtains lists of components to be repaired via the TPS/ATE approach from the WSS's; however, failure rates and end item densities may typically come from other sources or documents and these are used to project expected component activity on the ATE's. The PMO TMDS then uses an internal formula for computing expected component connect times (thruput calculation) to the ATE. These total failures, times, and local decisions of repair echelons are rolled up in a workload formula to obtain number of ATE's to support all the weapon systems.

Clearly improvements to this procedure can be made. One improvement already has been recommended; Ferguson et al. [1] have suggested adjustments to the thruput formulae used by PMO/TMDS. Another change in procedure (see BETTER in Figure 3) is to allow the local users (WSS's) to use the thruput formulae for hookup and connect times and use a consistent data base on failure rates, end item usage and densities in order to compute their own fractional ATE requirements. These fractional ATE requirements, based on local preference for GS/Depot repair, would then be fed to the CDM for aggregation over all WSS's. Some adjustment of these rolled up fractions to obtain some minimal yet feasible integer quantities could then be made. This approach will be termed the MACRO workloading piecemeal approach in the procedural outline in Chapter 6.

Still further improvements can be made (see BEST in Figure 3) if the logistical costs of local decisions are forwarded also to the CDM. It could be ideal if these decisions and costs are obtained using some standard ORLA modelling as shown in Chapter 2. A diagram of the flow of information and decision making in this ideal case is shown in Figure 4.

## BIBLIOGRAPHY

- 1 Ferguson, G. et al, An Analysis of the PM-ATSS Workload Analysis Model for the AN/USM-410 ATE, May 1983, AMSAA, Technical Report #393, Aberdeen Proving Ground.
- 2 Kaplan, A. and D. Orr, The OATMEAL Model, February 1983, AMSAA Inventory Research Office, Technical Report USAIRO-TR-83/2, AD #A136690, Philadelphia, PA.
- 3 Kasian, Walt, The Kasian Model, February 1982, USA Electronics Research & Development Command, Internal Working Paper TPS.FIN 2/15/82.
- 4 Seaberg, E. and R. Howe, LOCAM 5 Programmer/Users Manual, February 1977, RCA/Govt & Commercial Systems, Technical Report D-77-2. Available from Systems Analysis Division, Plans & Analysis Directorate, US Army MICOM, Redstone Arsenal, AL.
- 5 White, R.D. and D. Tyburski, Generalized Electronics Maintenance Model (GEMM), November 1971, USA Electronics Command, Technical Report #ECOM-3502, Fort Monmouth, NJ.

APPENDIX A

POTENTIAL DECREASE IN NUMBER OF ATEs USING CAMEL (CENTRALIZED DECISION)

Let's assume that the decisions involve placing ATEs in N deployment areas (N GSUs, 1 Depot) in order to support S types of weapon systems (S local users).

There are then N+1 constraints on fractional ATE requirements when decentralized decisions are used. These "fractionals" actually consist of integer parts "I", and fractions, which when added together, yield another integer in meeting a constraint. Specifically,

$$\begin{array}{rcl}
 \sum_{S} FD & \longrightarrow & \sum_{S} I_D + \{\text{integer between 0 and } S-1\} \\
 \\
 \text{Area 1 } \sum_{S} FG_1 & \longrightarrow & \sum_{S} I_{G_1} + \{\text{integer between 0 and } S-1\} \\
 \\
 \text{Area k } \sum_{S} FG_k & \longrightarrow & \sum_{S} I_{G_k} + \{\text{integer between 0 and } S-1\} \\
 \\
 \text{Area N } \sum_{S} FG_N & \longrightarrow & \sum_{S} I_{G_N} + \{\text{integer between 0 and } S-1\}
 \end{array}$$

N  
Relations

When using a centralized decision model, the requirements on the S systems are considered together. The constraint equations (p.16) then yield "fractionals" as such:

$$\begin{array}{rcl}
 \sum_{S} FD & \longrightarrow & \sum_{S} I_D + \{\text{integer between 0 and } S-1\} \\
 \\
 \sum_{S} \sum_{k=1}^N FG_k & \longrightarrow & \sum_{S} I_G + \{\text{integer between 0 and } S-1\} \\
 \\
 \text{where } I_G & = & \sum_{k=1}^N I_{G_k}
 \end{array}$$

Then since

$$\sum_{k=1}^N \sum_{r=1}^S I_{k,r} = \sum_{k=1}^N \sum_{r=1}^S I_{k,r} ,$$

the difference in the two approaches are in the number of occurrences of {integer between 0, S-1}. Notationally we have:

Potential for decrease in ATEs is:

$$N \times [0, S-1] - [0, S-1]$$

Let us interpret these mathematical results in terms of several approaches to the basic problem. There are basically three methods of computing and filling common requirements for a set of S systems at a collection of N locations (1 Depot and N-1 GSUS).

(1) The optimal fractional requirements can be computed and filled separately for each system at each location. That is, for each system, the optimal requirements distribution (based on minimal logistic cost) could be calculated and then at each location there would be placed the minimal (integral) number of ATEs necessary to fill that system's requirements. Consequently each weapon system would have a set of ATEs at each location which in essence provide dedicated support for that system.

(2) The optimal fractional requirements can be computed separately for each system, but at each location these requirements are filled jointly. Thus, as above, for each system the optimal requirements (based on minimal logistics cost) could first be calculated. But then at each location the minimal integral number of ATEs would be situated so as to fill all the fractional system requirements.

(3) The optimal fractional requirements can be computed and filled jointly (centrally) for all the S systems at once. This optimal requirements distribution would be based on minimizing the total procurement costs for all the ATEs with the sum of all the system logistics costs.

Using Method (1), at each location there is an integer number of ATEs to satisfy each fractional requirement. Thus, at each location, each system requirement that is not a whole number generates an excess fill which is a proper fraction. The expected value of each of these proper fractions is 1/2. Since each location supports up to S systems, it would be expected to have approximately S/2 excess ATEs. Thus for all N locations, there is an expected total of NS/2 excess ATEs.

Using Method (2), at each location the number of excess ATEs is at

most a proper fraction. Since each of these fractions has an expected value of  $1/2$ , the collection of  $N$  locations has an expected excess capacity of  $N/2$  ATEs.

Thus, the expected savings in ATE procurement from using Method (2) rather than Method (1), is  $N(S-1)C/2$ , where  $C$  is the procurement price of one ATE. Under the assumptions mentioned above, the expected savings from using Method (3) rather than Method (2) would be  $(N-1)C/2$ .

The CAMEL is close to method (3). It is not quite method (3) since for each system only three requirements distributions are considered: all requirements at depot, all requirements allocated equally among the GSUS, that requirements distribution for system which minimizes the logistics cost. As mentioned in the main report, it is not practical for a CDM to "take over" and find the global least cost solution over all distributions over all systems. However, CAMEL is sub-optimal and, based on equation (A1), approximates the expected savings.

## APPENDIX B

### SETUP OF APEX II RUN

An integer linear program package called APEX II can be used to run problems of the type in Chapter 5. One version of this package is on the CDC computer at Picatinny Arsenal. To run the sample problem, a control language file ACL and a file MATRIX representing the constraint and coefficient values are set up.

```
Then ATTACH, APEXIIR, APEX2R, ID = MISMAID.  
      APEXIIR (ACL,GO)
```

will run the job after ACL and MATRIX have been attached.

```
FILE      ACL  
          TITLE MIXED INTEGER  
          CONVERT SOURCE=MATRIX,IDENT=MEDA  
          PICTURE SOURCE=MEDA  
          READY SOURCE=MEDA,IDENT=WORKA  
          SETUP SOURCE=WORKA  
          SET W.OBJ=ZM*N,W.RHS=RHS  
          SET T.OPTCR=0.0  
          MIXINT  
          RECORD PRINT  
          EXIT  
ENDFILE
```

FILE	MATRIX		
LGL	ZMIN(F)		name of objective function
LGL	COND(P)	" -	Dept constraint
LGL	CON1(P)	" -	Area 1 "
LGL	CON2(P)	" -	2 "
LGL	CON3(P)	" -	3 "
LGL	WA1(Z)	}	names of constraints of type $a_0 + a_1 + a_2 = 1$
LGL	WA2(Z)		
LGL	WA3(Z)		
LGL	WA4(Z)		
LGL	WA5(Z)		
STR	TD(I),LIMIT=6	}	ATE variables
STR	TG1(I),LIMIT=4		
STR	TG2(I),LIMIT=4		
STR	TG3(I),LIMIT=4	}	0-1 Binary decision variables
STR	AD1(BIN)		
STR	AG1(BIN)		
STR	AO1(BIN)		
STR	AD2(BIN)		
STR	AG2(BIN)		
STR	AO2(BIN)		
STR	AD3(BIN)		
STR	AG3(BIN)		
STR	AO3(BIN)		
STR	AD4(BIN)		
STR	AG4(BIN)		
STR	AO4(BIN)		
STR	AD5(BIN)		
STR	AG5(BIN)		
STR	AO5(BIN)		
AIJ	ZMIN, TD=2.0	}	values of coefficients associated with each variable occurring in a named row
AIJ	ZMIN, TG1=2.0		
AIJ	ZMIN, TG2=2.0		
AIJ	ZMIN, TG3=2.0		
AIJ	ZMIN, AD1=3.2		
AIJ	ZMIN, AG1=3.3		
AIJ	ZMIN, AO1=3.0		
AIJ	ZMIN, AD2=2.15		
AIJ	ZMIN, AG2=2.05		
AIJ	ZMIN, AO2=2.0		
AIJ	ZMIN, AD3=4.3		
AIJ	ZMIN, AG3=4.1		
AIJ	ZMIN, AO3=4.0		
AIJ	ZMIN, AD4=5.3		
AIJ	ZMIN, AG4=5.5		
AIJ	ZMIN, AO4=5.0		
AIJ	ZMIN, AD5=3.5		
AIJ	ZMIN, AG5=3.9		
AIJ	ZMIN, AO5=3.5		
AIJ	COND, AD1=1.1		
AIJ	COND, AO1=.5		
AIJ	COND, AD2=.5		
AIJ	COND, AO2=.2		

```

AIJ      COND,AD3=1.2
AIJ      COND,A03=.7
AIJ      COND,AD4=.6
AIJ      COND,A04=.4
AIJ      COND,AD5=1.0
AIJ      COND,A05=1.0
AIJ      COND,TD=-1.0
AIJ      CON1,AG1=.367
AIJ      CON1,A01=.2
AIJ      CON1,AG4=.3
AIJ      CON1,A04=.1
AIJ      CON1,AG5=.33
AIJ      CON1,TG1=-1.0
AIJ      CON2,AG1=.367
AIJ      CON2,A01=.2
AIJ      CON2,AG2=.25
AIJ      CON2,A02=.15
AIJ      CON2,AG3=1.2
AIJ      CON2,A03=.5
AIJ      CON2,AG5=.33
AIJ      CON2,TG2=-1.0
AIJ      CON3,AG1=.367
AIJ      CON3,A01=.2
AIJ      CON3,AG2=.25
AIJ      CON3,A02=.15
AIJ      CON3,AG4=.3
AIJ      CON3,A04=.1
AIJ      CON3,AG5=.33
AIJ      CON3,TG3=-1.0
AIJ      WA1,AD1=1.0
AIJ      WA1,AG1=1.0
AIJ      WA1,A01=1.0
AIJ      WA2,AD2=1.0
AIJ      WA2,AG2=1.0
AIJ      WA2,A02=1.0
AIJ      WA3,AD3=1.0
AIJ      WA3,AG3=1.0
AIJ      WA3,A03=1.0
AIJ      WA4,AD4=1.0
AIJ      WA4,AG4=1.0
AIJ      WA4,A04=1.0
AIJ      WA5,AD5=1.0
AIJ      WA5,AG5=1.0
AIJ      WA5,A05=1.0
RHS      COND,RHS=0.0
RHS      CON1,RHS=0.0
RHS      CON2,RHS=0.0
RHS      CON3,RHS=0.0
RHS      WA1,RHS=1.0
RHS      WA2,RHS=1.0
RHS      WA3,RHS=1.0
RHS      WA4,RHS=1.0
RHS      WA5,RHS=1.0
ENDFILE

```

values of coefficients

value given to right hand side  
of a named row

## APPENDIX C

### SUMMARY OF ORLA MODELS

#### OATNEAL

##### Type of Model

An optimizer (mixed integer LP) which finds the best multi-echelon stockage, TE, and maintenance policy decisions.

##### Input Data

Moderate detail like GEMM. Set up is not especially tedious. Run times experienced with the mixed integer LP have not been long or expensive.

##### Decision Making Properties

Computes a steady state cost converted to present value. Maintenance policies can be constrained (35 maintenance policies are available. All or most are typically considered in a single run). Stockage and maintenance policies are found simultaneously to achieve a weapon system target availability at least cost. Decisions are made by application (failure mode). System peculiar TE and manpower are allocated in integer amounts to the echelon.

Extensive sensitivity analyses could be expensive. But a back end evaluator allows quick analyses of changes to backorder penalties and to individual component policies. Evaluator also bypasses mixed integer LP optimizer when maintenance policies are tightly constrained across many components.

##### Assumptions and Limitations

Symmetrical support structure is assumed. Two indentures (LRU, module, with piece part costs considered by averages by module).

##### Special Capabilities or Enhancements

Weapon system availability target can be met (uses special search subroutine).

Optimization of integer allocation of STE is built in.

Evaluator converts optimal maintenance decisions by failure mode to the optimal replacement and maintenance task distributions (RTD, MTD) for the components. Mixed tasking is allowable (e.g. 50% repair at DS, 50% at GS for component i).

SESAME subroutine finds multi-echelon stockage.

Planned Enhancements

Several alternative sets of TE (e.g. STE vs TPS/ATE) can be considered simultaneously in a single optimization.

Accepts new component applications and finds best policy without a rerun of LP. Accepts new constraints on TPS/ATE placement and evaluates impact.

Meets Minimal Requirements of an ORLA for:

- TPS decision making? Yes, optimally. And eliminates from consideration reparable components for which TPS is not cost effective.
- Feeding an ATE requirements and allocation model? Yes.

## LOGAM-LOCAM

### Type of Model

A deterministic simulator used as an evaluator of alternative maintenance policies.

### Input Data

Extensive detail, used to construct accounting type cost equations. Setup and run times are long and computer costs are relatively expensive.

### Decision Making Properties

Computes present value of system life cycle cost. Can also provide dynamic costing over time. Availability of end item can be measured and tracked dynamically over life horizon. Maintenance policies can be constrained (20 max, usually 3-5 considered in a run). Sensitivity analysis is available but expensive.

### Assumptions and Limitations

Symmetrical support structure is assumed. Stockage policy is non-optimal (fixed k st. deviations for safety level). Target availability cannot be guaranteed. Three indentures (LRU, module, part). Maintenance policies can differ only by classes of LRU's. Alternatives (STE) to TPS/ATE cannot be considered in the same run. Integer constraints on weapon system peculiar TE are satisfied by a posteriori integer round up.

### Special Capabilities or Enhancements

Can give time profiles of costs and availability over the life horizon of the weapon system.

### Meets Minimal Requirements of an ORLA for:

- TPS decision making? Yes.
- Feeding an ATE requirements and allocation model? Yes, with modification to output, it can provide logistics costs of decisions and fractional ATE.

## KASIAN

### Type of Model

For an individual component, a simple cost accounting formula of the LCCs based on the life time expected failures. Evaluates 4 decisions: throwaway at GS with or without a function test, repair at GS, repair at depot.

### Input Data

Very moderate. A majority of potential input parameters are currently imbedded in the cost formulae.

### Decision Making Properties

Computes present value of life cycle cost of a single component for the four alternatives.

### Assumptions and Limitations

Assumes costs of operations for the component at or below DS are equal for all four alternatives. Assumes specific values for many imbedded parameters. Transportation, packaging and handling costs are ignored. Initial stockage cost is ignored; no safety level; replenishment is simple yearly pipeline. Piece part costs assumed to be 15% of component. No weapon system synthesis or interaction of component decisions; no availability measure. No alternatives (STE) to TPS/ATE can be considered without special modification. Total weapon system ATE requirements are not readily available.

Especially inferior when several components are reparable by a single TE.

### Special Capabilities or Enhancements

Sensitivity analysis on each component decision can be made quickly and cheaply. Program is portable (back of envelope, hand calculator).

### Meets Minimal Requirements for an ORLA for:

• TPS decision making? Qualified yes. TPS decisions on a component by component basis could be changed if the entire weapon system is analyzed. The model is useful for early screening to obtain a list of components as potential candidates for TPS. The calculation of ATE thruput for these candidates is then indicated, for use in the other ORLA models.

• Feeding an ATE requirements and allocation model? No, it cannot supply the inputs for the new alternatives (see chart) for obtaining ATE workload requirements.

## GEMM

### Type of Model

Cost accounting equations of steady state requirements. Used as an evaluator of alternative maintenance policies.

### Input Data

Moderate detail. Set up and run times are not especially long or expensive.

### Decision Making properties

Computes a steady state annual cost requirement. Maintenance policies can be constrained (35 maintenance policies are available. Usually 3-5 are considered in a single run).

### Assumptions & Limitations

Symmetrical support structure is assumed. Stockage policy is non-optimal (pipeline and fixed k std deviation for safety level). Target availability cannot be guaranteed. Two indentures (LRU, module, with piece part costs considered by class averages). Maintenance policies can differ by LRU and modules. As with LOGAM-LOCAM, mechanisms of choice do not exist for allocating stockage quantities and TE by echelons and then determining what constraints and what cost impact these allocations have on the maintenance policy decision. Conflicts between LRU and module maintenance concepts are disallowed. Alternatives (STE) to TPS/ATE cannot be considered in the same run.

If the ATE is system peculiar, the program has the option of rounding up, a posteriori, a fractional ATE at a given support unit.

### Special Capabilities or Enhancements

Sensitivity analysis is relatively convenient for such a large ORLA and cheaper than LOGAM-LOCAM.

### Meets Minimal Requirements of an ORLA for:

- TPS decision making? Yes.
- Feeding an ATE requirements and allocation model (ATERA)?

Yes if logistics costs are modified to be consistent with other ORLA models that will be used to feed ATERA.

## APPENDIX D

### GLOSSARY OF ACRONYMS AND TERMS

LORA	- Level of Repair Analysis Models
ORLA	- Optimum Repair Level Analysis Models
TMDE(S)	- Test, Maintenance, and Diagnostic Equipment (System)
ATE	- Automatic Test Equipment - used in this report to denote common, multipurpose TMDE
STE	- Special Test Equipment
MOS	- Military Operational Skill
DSU	- Direct Support Unit
GSU	- General Support Unit
TPS	- Test Program Set
ICD	- Interconnect Device
CARAMEL	- Cooperative Assignment of Requirements for Automatic Multipurpose Test Equipment by Location
LRU	- Line Replaceable Unit - usually a first indenture assembly. In this report usually interchangeable with the term <u>component</u> .
SRU	- Shop Replaceable Unit - usually a second indenture part. In this report usually interchangeable with the term <u>module</u> .
CDM	- Centralized Decision Maker
PMO	- Project Managers Office
WSS	- Weapon System
EQUATE	- An important Army ATE
SESAME	- Selected Essential Item Stockage for Availability Method The Army's Multiechelon Stockage Model
OATMEAL	- Optimal Allocation of Test Equipment and Manpower Evaluated Against Logistics



DISTRIBUTION

COPIES

<u>1</u>	Deputy Under Sec'y of the Army, ATTN: Office of Op Resch
<u>1</u>	Asst Sec'y of the Army (I,L&FM), Pentagon, Wash., DC 20310
	Headquarters, US Army Materiel Development & Readiness Command
<u>1</u>	Commander
<u>2</u>	DRCDM-S
<u>1</u>	DRCSM-E
<u>1</u>	DRCSM-W
<u>1</u>	DRCSM-WR
<u>1</u>	DRCSM-WRS
<u>1</u>	DRCSM-I
<u>1</u>	DRCSM-P
<u>1</u>	DRCRE
<u>1</u>	DRCTM-E
	Dep Chf of Staff for Logistics, Pentagon, Wash., DC 20310
<u>1</u>	DALO-SMP-U
<u>1</u>	Ofc, Asst Sec'y of Defense, ATTN: MRA&L-SR, Pentagon, Wash., DC 20310
<u>1</u>	Commandant, US Army Logistics Management Center, Ft. Lee, VA 23801
<u>2</u>	Defense Technical Info Center, Cameron Station, Alexandria, VA 22314
	Commander, USA Armament Munitions & Chemical Cmd, Rock Island, IL 61299
<u>1</u>	DRSMC-MM(R)
<u>1</u>	DRSMC-SA(R)
	Commander, USA Missile Command, Redstone Arsenal, AL 35898
<u>1</u>	DRSMI-S <u>1</u> DRSMI-DL <u>1</u> DRSMI-SS
<u>1</u>	DRSMI-D <u>1</u> DRSMI-SN
	Commander, USA Troop Support & Aviation Materiel Readiness Command, St. Louis, MO 63120
<u>1</u>	DRSTS-S
<u>1</u>	DRSTS-M
<u>1</u>	DRSTS-BA
	Commander, US Army Tank-Automotive Command, Warren, MI 48090
<u>1</u>	DRSTA-F <u>1</u> DRSTA-V
<u>1</u>	DRSTA-M <u>1</u> DRSTA-MS
	Commander, USA Communications-Electronics Cmd, Ft. Monmouth, NJ 07703
<u>1</u>	DRSEL-MM
<u>1</u>	DRSEL-PL-SA <u>1</u> DRSEL-ME
<u>1</u>	Commander, USA Aviation R&D Cmd, 4300 Goodfellow Blvd, St. Louis, MO 63120
<u>1</u>	Commander, USA Aviation R&D Cmd, ATTN: DRDAV-BD (Marl Glenn), 4300 Goodfellow Blvd, St. Louis, MO 63120
<u>1</u>	Commander, USA Electronics R&D Cmd, ATTN: DRDEL-PO-SA, Rm 2D315, Bldg. 2700, Ft. Monmouth, NJ 07703
<u>1</u>	Commander, USA Mobility Equipment R&D Cmd, ATTN: DRDME-US (Leon Medler) Ft. Belvoir, VA 22060
<u>1</u>	Commander, USA Natick R&D Cmd, ATTN: DRXNM-O, Natick, MA 01760
	Director, Army Materiel Systems Analysis Activity, APG, MD 21005
<u>1</u>	DRXSY-R
<u>1</u>	DRXSY-RE
<u>1</u>	DRXSY-RM
<u>1</u>	DRXSY-RV
<u>1</u>	DRXSY-L

<u>1</u>	DRXSY-LX
<u>1</u>	DRXSY-LA
<u>1</u>	DRXSY-LM
<u>1</u>	DRXSY-LR
<u>1</u>	DRXSY-LO
<u>2</u>	DRXSY-PM
<u>1</u>	Commander, US Army Logistics Center, Ft. Lee, VA 23801
<u>1</u>	Commander, US Army Logistics Evaluation Agency, New Cumberland Army Depot, New Cumberland, PA 17070
<u>1</u>	US Navy Fleet Materiel Support Office, Naval Support Depot, Operations Analysis Department, Code 93, Mechanicsburg, PA 17055
<u>1</u>	Naval Postgraduate School, ATTN: Dept of Opns Anal, Monterey, CA 93940
<u>1</u>	Air Force Institute of Technology, ATTN: SLGQ Head Quantitative Studies Dept., Dayton, OH 43433
<u>1</u>	Commander, US Army Logistics Center, ATTN: Concepts & Doctrine Directorate, Ft. Lee, VA 23801
<u>1</u>	RAND Corp., ATTN: S. M. Drezner, 1700 Main St., Santa Monica, CA 90406
<u>1</u>	Defense Logistics Agcy, ATTN: DLA-LO, Cameron Sta, Alexandria, VA 22314
<u>1</u>	Commander, US Army Communications Command, ATTN: Dr. Forry, CC-LOG-LEO, Ft. Huachuca, AZ 85613
<u>1</u>	Commander, US Army Test & Evaluation Cmd, ATTN: DRSTE-SY, Aberdeen Proving Ground, MD 21005
<u>1</u>	Project Manager, ATSS, ATTN: DRCPM-ATSS, Ft. Monmouth, NJ 07703

# GIST

 <p>US ARMY MATERIEL SYSTEMS ANALYSIS ACTIVITY <b>AMSAA</b></p>	<p><b>TITLE</b> THE COOPERATIVE ASSIGNMENT OF RE- QUIREMENTS FOR AUTOMATIC MULTIPURPOSE TEST EQUIPMENT BY LOCATION (CAMEL) (U)</p>	 <p>U.S. ARMY MATERIEL COMMAND</p>
--	--	---

THE PRINCIPAL FINDINGS and recommendations of the work reported herein are as follows:

The current process for determining the requirements and location of multipurpose Automatic Test Equipment (ATE) across weapon systems is sub-optimal. This report indicates an algorithm and associated procedures for consolidating individual weapon systems (local) ATE requirements by a centralized decision maker.

THE MAIN ASSUMPTIONS on which the work reported herein rests are as follows:

Local decision makers can compute their individual ATE requirements and the logistics costs of repairing their assemblies at certain echelons.

THE PRINCIPAL LIMITATIONS of this work which may affect the findings are as follows:

Availability of timely data and the coordination of local decision makers.

THE SCOPE OF THE STUDY was to assess the steady state (no surge) requirement of test equipment which are used to fix many types of reparable assemblies at two or more echelons.

THE STUDY OBJECTIVE was to improve the mathematical and operational procedures used for ATE requirements and to point out pitfalls.

THE BASIC APPROACH: An integer linear program was developed around which guidance for local and central decision makers was built.



THE REASON FOR PERFORMING THE STUDY was researchers felt a need for this model, which is a companion to optimal repair level models, such as OATMEAL.

THE STUDY SPONSOR - None.

THE STUDY EFFORT was directed by IRO.

COMMENTS AND QUESTIONS may be directed to Don Orr, IRO, Autovon 444-3808.

# GIST

 <p>AMSAA</p>	<p><b>TITLE</b> THE COOPERATIVE ASSIGNMENT OF RE- QUIREMENTS FOR AUTOMATIC MULTIPURPOSE TEST EQUIPMENT BY LOCATION (CAMEL) (U)</p>	
--	--	---

THE PRINCIPAL FINDINGS and recommendations of the work reported herein are as follows:

The current process for determining the requirements and location of multipurpose Automatic Test Equipment (ATE) across weapon systems is sub-optimal. This report indicates an algorithm and associated procedures for consolidating individual weapon systems (local) ATE requirements by a centralized decision maker.

THE MAIN ASSUMPTIONS on which the work reported herein rests are as follows:

Local decision makers can compute their individual ATE requirements and the logistics costs of repairing their assemblies at certain echelons.

THE PRINCIPAL LIMITATIONS of this work which may affect the findings are as follows:

Availability of timely data and the coordination of local decision makers.

THE SCOPE OF THE STUDY was to assess the steady state (no surge) requirement of test equipment which are used to fix many types of reparable assemblies at two or more echelons.

THE STUDY OBJECTIVE was to improve the mathematical and operational procedures used for ATE requirements and to point out pitfalls.

THE BASIC APPROACH: An integer linear program was developed around which guidance for local and central decision makers was built.



THE REASON FOR PERFORMING THE STUDY was researchers felt a need for this model, which is a companion to optimal repair level models, such as OATMEAL.

THE STUDY SPONSOR - None.

THE STUDY EFFORT was directed by IRO.

COMMENTS AND QUESTIONS may be directed to Don Orr, IRO, Autovon 444-3808.

# GIST

 <p>US ARMY MATERIEL SYSTEMS ANALYSIS ACTIVITY <b>AMSAA</b></p>	<p><b>TITLE</b> THE COOPERATIVE ASSIGNMENT OF RE- QUIREMENTS FOR AUTOMATIC MULTIPURPOSE TEST EQUIPMENT BY LOCATION (CAMEL) (U)</p>	 <p>U.S. ARMY MATERIEL COMMAND</p>
--	--	---

THE PRINCIPAL FINDINGS and recommendations of the work reported herein are as follows:

The current process for determining the requirements and location of multipurpose Automatic Test Equipment (ATE) across weapon systems is sub-optimal. This report indicates an algorithm and associated procedures for consolidating individual weapon systems (local) ATE requirements by a centralized decision maker.

THE MAIN ASSUMPTIONS on which the work reported herein rests are as follows:

Local decision makers can compute their individual ATE requirements and the logistics costs of repairing their assemblies at certain echelons.

THE PRINCIPAL LIMITATIONS of this work which may affect the findings are as follows:

Availability of timely data and the coordination of local decision makers.

THE SCOPE OF THE STUDY was to assess the steady state (no surge) requirement of test equipment which are used to fix many types of reparable assemblies at two or more echelons.

THE STUDY OBJECTIVE was to improve the mathematical and operational procedures used for ATE requirements and to point out pitfalls.

THE BASIC APPROACH: An integer linear program was developed around which guidance for local and central decision makers was built.



THE REASON FOR PERFORMING THE STUDY was researchers felt a need for this model, which is a companion to optimal repair level models, such as OATMEAL.

THE STUDY SPONSOR - None.

THE STUDY EFFORT was directed by IRO.

COMMENTS AND QUESTIONS may be directed to Don Orr, IRO, Autovon 444-3808.

# GIST

 <p>AMSAA</p>	<b>TITLE</b> THE COOPERATIVE ASSIGNMENT OF REQUIREMENTS FOR AUTOMATIC MULTIPURPOSE TEST EQUIPMENT BY LOCATION (CAMEL) (U)	
--	--	---

THE PRINCIPAL FINDINGS and recommendations of the work reported herein are as follows:

The current process for determining the requirements and location of multipurpose Automatic Test Equipment (ATE) across weapon systems is sub-optimal. This report indicates an algorithm and associated procedures for consolidating individual weapon systems (local) ATE requirements by a centralized decision maker.

THE MAIN ASSUMPTIONS on which the work reported herein rests are as follows:

Local decision makers can compute their individual ATE requirements and the logistics costs of repairing their assemblies at certain echelons.

THE PRINCIPAL LIMITATIONS of this work which may affect the findings are as follows:

Availability of timely data and the coordination of local decision makers.

THE SCOPE OF THE STUDY was to assess the steady state (no surge) requirement of test equipment which are used to fix many types of repairable assemblies at two or more echelons.

THE STUDY OBJECTIVE was to improve the mathematical and operational procedures used for ATE requirements and to point out pitfalls.

THE BASIC APPROACH: An integer linear program was developed around which guidance for local and central decision makers was built.



THE REASON FOR PERFORMING THE STUDY was researchers felt a need for this model, which is a companion to optimal repair level models, such as OATMEAL.

THE STUDY SPONSOR - None.

THE STUDY EFFORT was directed by IRO.

COMMENTS AND QUESTIONS may be directed to Don Orr, IRO, Autovon 444-3808.

# GIST

 <p>AMSAA</p>	<p><b>TITLE</b> THE COOPERATIVE ASSIGNMENT OF RE- QUIREMENTS FOR AUTOMATIC MULTIPURPOSE TEST EQUIPMENT BY LOCATION (CAMEL) (U)</p>	
--	--	---

THE PRINCIPAL FINDINGS and recommendations of the work reported herein are as follows:

The current process for determining the requirements and location of multipurpose Automatic Test Equipment (ATE) across weapon systems is sub-optimal. This report indicates an algorithm and associated procedures for consolidating individual weapon systems (local) ATE requirements by a centralized decision maker.

THE MAIN ASSUMPTIONS on which the work reported herein rests are as follows:

Local decision makers can compute their individual ATE requirements and the logistics costs of repairing their assemblies at certain echelons.

THE PRINCIPAL LIMITATIONS of this work which may affect the findings are as follows:

Availability of timely data and the coordination of local decision makers.

THE SCOPE OF THE STUDY was to assess the steady state (no surge) requirement of test equipment which are used to fix many types of reparable assemblies at two or more echelons.

THE STUDY OBJECTIVE was to improve the mathematical and operational procedures used for ATE requirements and to point out pitfalls.

THE BASIC APPROACH: An integer linear program was developed around which guidance for local and central decision makers was built.



THE REASON FOR PERFORMING THE STUDY was researchers felt a need for this model, which is a companion to optimal repair level models, such as OATMEAL.

THE STUDY SPONSOR - None.

THE STUDY EFFORT was directed by IRO.

COMMENTS AND QUESTIONS may be directed to Don Orr, IRO, Autovon 444-3808.

# GIST

 <p>AMSAA</p>	<p><b>TITLE</b> THE COOPERATIVE ASSIGNMENT OF RE- QUIREMENTS FOR AUTOMATIC MULTIPURPOSE TEST EQUIPMENT BY LOCATION (CAMEL) (U)</p>	
--	--	---

THE PRINCIPAL FINDINGS and recommendations of the work reported herein are as follows:

The current process for determining the requirements and location of multipurpose Automatic Test Equipment (ATE) across weapon systems is sub-optimal. This report indicates an algorithm and associated procedures for consolidating individual weapon systems (local) ATE requirements by a centralized decision maker.

THE MAIN ASSUMPTIONS on which the work reported herein rests are as follows:

Local decision makers can compute their individual ATE requirements and the logistics costs of repairing their assemblies at certain echelons.

THE PRINCIPAL LIMITATIONS of this work which may affect the findings are as follows:

Availability of timely data and the coordination of local decision makers.

THE SCOPE OF THE STUDY was to assess the steady state (no surge) requirement of test equipment which are used to fix many types of reparable assemblies at two or more echelons.

THE STUDY OBJECTIVE was to improve the mathematical and operational procedures used for ATE requirements and to point out pitfalls.

THE BASIC APPROACH: An integer linear program was developed around which guidance for local and central decision makers was built.

THE REASON FOR PERFORMING THE STUDY was researchers felt a need for this model, which is a companion to optimal repair level models, such as OATMEAL.

THE STUDY SPONSOR - None.

THE STUDY EFFORT was directed by IRO.

COMMENTS AND QUESTIONS may be directed to Don Orr, IRO, Autovon 444-3808.

**END**

**FILMED**

**10-85**

**DTIC**