

AD-A157 716

LIMITED AIRWORTHINESS AND FLIGHT CHARACTERISTICS (RAFC)  
TEST OF THE QUICK. (U) ARMY AVIATION ENGINEERING FLIGHT  
ACTIVITY EDWARDS AFB CA G L SKINNER ET AL. OCT 84

1/1

UNCLASSIFIED

USAREFA-83-20

F/G 1/3

NL

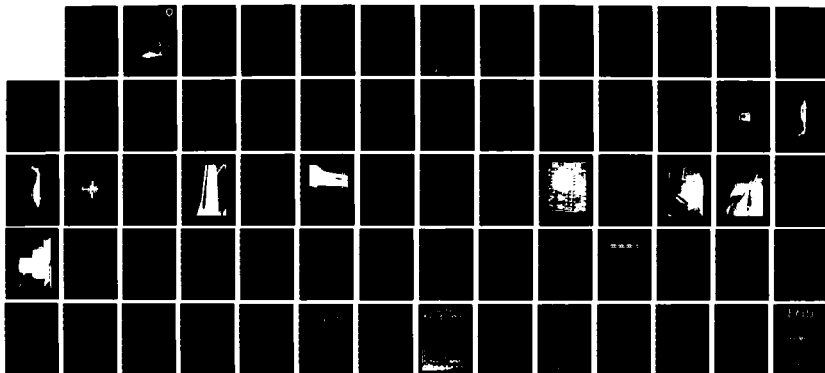

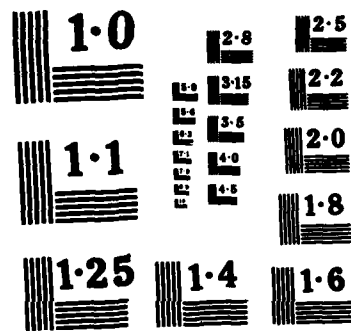

NATIONAL BUREAU OF STANDARDS  
MICROCOPY RESOLUTION TEST CHART

AD-A157 716

USAAEFA

DTIC FILE COPY

USAAEFA PROJECT NO. 83 - 20

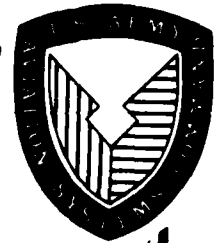

# LIMITED AIRWORTHINESS AND FLIGHT CHARACTERISTICS (A&FC) TEST OF THE QUICK FIX CONFIGURATION

GARY L. SKINNER  
PROJECT OFFICER / ENGINEER

EDWARD J. TAVARES  
MAJ, AV  
PROJECT PILOT

GARY M. BISHOP  
CPT, AV  
PROJECT ENGINEER

REGINALD C. MURRELL  
CW4, AV  
PROJECT PILOT

OCTOBER 1984

FINAL REPORT

DTIC  
ELECTE  
S AUG 5 1985 D  
A



APPROVED FOR PUBLIC RELEASE, DISTRIBUTION UNLIMITED.

UNITED STATES ARMY AVIATION ENGINEERING FLIGHT ACTIVITY  
EDWARDS AIR FORCE BASE, CALIFORNIA 93523

85 7 22 052

#### **DISCLAIMER NOTICE**

**The findings of this report are not to be construed as an official Department of the Army position unless so designated by other authorized documents.**

#### **DISPOSITION INSTRUCTIONS**

**Destroy this report when it is no longer needed. Do not return it to the originator.**

#### **TRADE NAMES**

**The use of trade names in this report does not constitute an official endorsement or approval of the use of the commercial hardware and software.**

UNCLASSIFIED

SECURITY CLASSIFICATION OF THIS PAGE (When Data Entered)

REPORT DOCUMENTATION PAGE		READ INSTRUCTIONS BEFORE COMPLETING FORM
1. REPORT NUMBER USAAEFA <del>XXXXXXXXXX</del> 83-20	2. GOVT ACCESSION NO. AD-A157716	3. RECIPIENT'S CATALOG NUMBER
4. TITLE (and Subtitle) LIMITED AIRWORTHINESS & FLIGHT CHARACTERISTICS (A&FC) TEST OF THE QUICK FIX CONFIGURATION	5. TYPE OF REPORT & PERIOD COVERED FINAL 23 MAY - 27 JUNE 1984	
	6. PERFORMING ORG. REPORT NUMBER	
7. AUTHOR(s) GARY L. SKINNER      EDWARD J. TAVARES GARY M. BISHOP      REGINALD C. MURRELL	8. CONTRACT OR GRANT NUMBER(s)	
9. PERFORMING ORGANIZATION NAME AND ADDRESS US ARMY AVN ENGINEERING FLIGHT ACTIVITY EDWARDS AIR FORCE BASE, CA 93523-5000	10. PROGRAM ELEMENT, PROJECT, TASK AREA & WORK UNIT NUMBERS EN-3-133ACO-1-EN-EC	
11. CONTROLLING OFFICE NAME AND ADDRESS US ARMY AVIATION SYSTEMS COMMAND 4300 GOODFELLOW BOULEVARD ST. LOUIS, MO 63120-1798	12. REPORT DATE OCTOBER 1984	
	13. NUMBER OF PAGES 70	
14. MONITORING AGENCY NAME & ADDRESS (If different from Controlling Office)	15. SECURITY CLASS. (of this report) UNCLASSIFIED	
	15a. DECLASSIFICATION/DOWNGRADING SCHEDULE	
16. DISTRIBUTION STATEMENT (of this Report)  Approved for public release; distribution unlimited.		
17. DISTRIBUTION STATEMENT (of the abstract entered in Block 20, if different from Report)		
18. SUPPLEMENTARY NOTES		
19. KEY WORDS (Continue on reverse side if necessary and identify by block number) Equivalent Flat Plate Area;      Quick Fix Configuration; Handling Qualities;      YEH-60A Helicopter; Level Flight Performance; Limited Airworthiness and Flight Characteristics Evaluation		
20. ABSTRACT (Continue on reverse side if necessary and identify by block number) The US Army Aviation Engineering Flight Activity conducted an evaluation to determine the increase in power required and the change in handling qualities due to the installation of the AN/ALQ-151(V)2 countermeasures system and associated mission equipment on the UH-60A helicopter. Testing conducted between 23 May and 27 June 1984 totaled 12.4 productive hours. The addition of the Quick Fix System and associated mission equipment created an increase in equivalent flat plate area ( $F_e$ ) of 17 square feet ( $ft^2$ ) for advance ratios (m)		

DD FORM 1473 EDITION OF 1 NOV 65 IS OBSOLETE

UNCLASSIFIED

SECURITY CLASSIFICATION OF THIS PAGE (When Data Entered)

UNCLASSIFIED

SECURITY CLASSIFICATION OF THIS PAGE(When Data Entered)

( $\mu$ ) of 0.26 and greater. For  $\mu$ 's less than 0.26, the change in  $F_e$  increased above 17  $ft^2$  as a function of thrust coefficient. Handling qualities of the Quick Fix configured YEH-60A were unchanged from a normal utility configured UH-60A and were determined satisfactory. One deficiency, interference between the main rotor blades and the upper elements of the (#3 and #4) direction finding dipole antennas during ground taxi, and four shortcomings were associated with the Quick Fix configuration. Keywords:

$\mu$ 's

sub e

sq ft

no.

to p A

UNCLASSIFIED

SECURITY CLASSIFICATION OF THIS PAGE(When Data Entered)



DEPARTMENT OF THE ARMY  
HEADQUARTERS, US ARMY AVIATION SYSTEMS COMMAND  
4300 GOODFELLOW BOULEVARD, ST. LOUIS, MO. 63120-1798

REPLY TO  
ATTENTION OF

AMSAV-E

SUBJECT: Directorate for Engineering Position on the Final Report of USAAEFA  
Project No. 83-20, Limited Airworthiness and Flight Characteristics  
(A&FC) Test of the YEH-60A Quick Fix System

SEE DISTRIBUTION

1. The purpose of this letter is to establish the Directorate for Engineering position on the subject report. The report substantiates that the handling qualities of the YEH-60A were unchanged from those of the basic UH-60A. The change in the drag characteristics resulting from external Quick Fix configuration modifications were documented and they were determined to be a function of the thrust coefficient.

2. This directorate agrees with the conclusions and recommendations except as indicated below. The following comments are provided and are addressed to the report paragraphs as indicated.

a. Paragraph 11 Line 7. The Quick Fix Mission does not require flat turns, however, initial calibration of the Quick Fix does. Also any recalibration of the system would require this maneuver.

b. Paragraph 16. The AN/ALQ-151 is designed to meet the vibration requirements of MIL-E-5400 and while any vibrations caused by the pitch oscillations during ground taxi are undesirable, there is no data in over one year of flight testing to indicate that these aircraft vibration have caused any major electronic equipment reliability problems.

c. Paragraph 24. The interference between the main rotor blades and rear DF dipole antennas is considered a deficiency and represents a safety problem. To alleviate the potential for the main rotor blades to strike the antennas, the YEH-60A has in the interim been restricted from taxiing rearward during ground operations. The Special Electronics Mission Aircraft (SEMA) Product Manager (PM) is implementing a Product Improvement Program (PIP) to change the antenna configuration from the dipole to a conformal one. Once incorporated, the current restriction to rearward taxi may be removed provided the spindle loads are acceptable.

d. Paragraph 25. The uncommanded directional control input was exhibited during the UH-60A A&FC evaluation under USAAEFA Project No. 77-17. The correction at that time was the incorporation of the -104 AFCS computer and the vendor Acceptance Test Procedure (ATP) change for the roll and yaw trim actuators;

AMSAV-E

**SUBJECT:** Directorate for Engineering Position on the Final Report of USAAEFA Project No. 83-20, Limited Airworthiness and Flight Characteristics (A&FC) Test of the YEH-60A Quick Fix System

however, the uncommanded input still persists, but is considered a shortcoming instead of a deficiency. Per coordination with the U.S. Army Test and Evaluation Command (TECOM) and organizational units that have the UH-60A assigned, the uncommanded input does not significantly detract from mission effectiveness. There are currently no plans to correct this problem.

e. Paragraph 26a. The lack of an ECM ANTENNA EXTENDED advisory light in the cockpit is considered a shortcoming. An Engineering Change Proposal (ECP) which will require an advisory light in the cockpit independent of radar altimeter was initiated by the SEMA PM. This action will correct the shortcoming.

f. Paragraph 26b. The excessively long and complicated normal alignment procedure for the AN/ASN-132 IINS was corrected. Software changes to the IINS and new procedures resulted in reducing the time to align to 6-8 minutes. This time is consistent with that required by similar systems.

g. Paragraph 26c. The poor location of the emergency ECM antenna retract switch is a shortcoming and consideration was given to relocating it. However, since the operational user did not consider it a problem, the switch was not moved, thereby resulting in a cost avoidance.

h. Paragraph 26d. The chafing of the AN/ALQ-144(V) power assembly harness was eliminated by rewiring the harness. This will be the fix in the production aircraft.

3. AVSCOM - Providing Leaders the Decisive Edge.

FOR THE COMMANDER:

*Daniel M. McEneany*  
DANIEL M. McENEANY  
Acting Director of Engineering

Accession For	
NTIS GRA&I	4
DTIC TAB	
Unannounced	
Justification	
By _____	
Distribution/	
Availability Codes	
Dist	Avail and/or Special
A1	



# TABLE OF CONTENTS

	<u>Page</u>
<b>INTRODUCTION</b>	
Background.....	1
Test Objectives.....	1
Description.....	1
Test Scope.....	2
Test Methodology.....	2
<b>RESULTS AND DISCUSSION</b>	
General.....	5
Level Flight Performance.....	5
Handling Qualities.....	6
Control Positions in Trimmed Forward Flight.....	6
Static Longitudinal Stability.....	7
Static Lateral-Directional Stability.....	7
Maneuvering Stability.....	7
Dynamic Stability.....	8
Ground Handling Characteristics.....	9
Pitch Oscillation During Ground Taxi.....	9
DF Antenna/Main Rotor Clearance.....	9
Low-Speed Flight Characteristics.....	9
Human Factors.....	10
ECM Antenna Advisory Light.....	10
Miscellaneous.....	10
Reliability and Maintainability.....	10
AN/ASN-132 IINS.....	10
AN/ALQ-144(V) IR Countermeasures Set.....	11
<b>CONCLUSIONS</b>	
General.....	12
Deficiencies.....	12
Shortcomings.....	12
Specification Compliance.....	13
<b>RECOMMENDATIONS.....</b>	<b>14</b>

APPENDIXES

A. References.....	15
B. Description.....	16
C. Instrumentation.....	34
D. Test Techniques and Data Analysis Methods.....	36
E. Test Data.....	44
F. Equipment Performance Reports.....	57

DISTRIBUTION

# INTRODUCTION

## BACKGROUND

1. The YEH-60A is a special Quick Fix electronic mission helicopter developed under management of the Special Electronic Mission Aircraft Product Manager. The YEH-60A Quick Fix System consists of a normal utility configured UH-60A helicopter modified to accept an AN/ALQ-151(V)2 countermeasures system. It was developed under a 1980 government contract with Electronic Systems Laboratory, TRW Inc. Preliminary contractor testing and modification has been completed. As part of the developmental testing of the YEH-60A Quick Fix System, the US Army Aviation Systems Command (AVSCOM), previously US Army Aviation Research and Development Command, requested the US Army Aviation Engineering Flight Activity (USAAEFA) conduct a limited airworthiness and flight characteristics (A&FC) test (ref 1, app A).

## TEST OBJECTIVES

2. Objectives of this test were to:

a. Obtain quantitative performance data to determine the change in drag characteristics between the normal utility UH-60A and YEH-60A Quick Fix configurations.

b. Obtain limited qualitative handling qualities data to determine if changes exist due to the installation of the AN/ALQ-151(V)2 countermeasures system and associated mission equipment.

## DESCRIPTION

3. The UH-60A is a twin-turbine, single main rotor configured helicopter capable of day and night operations under visual and instrument meteorological conditions (IMC). The main and tail rotors are four-bladed, with a capability of manual main rotor blade folding. The tail pylon incorporating a moveable horizontal stabilator is also capable of folding. The YEH-60A Quick Fix System consists of a UH-60A helicopter, US Army S/N 79-23301, modified to accept an AN/ALQ-151(V)2 countermeasures system. The AN/ALQ-151(V)2 countermeasures system consists of electronics contained in two rack assemblies and in two operator consoles located in the helicopter cabin and associated antennas consisting of two Ultra High Frequency antennas mounted on the underside of the fuselage, one retractable electronic countermeasures (ECM) antenna installed on the underside of the helicopter just forward of the transition section, a direction finding (DF)

dipole antenna set mounted on the tailcone exterior, and a built-in test equipment antenna located in the rear vertical section of the tail. The YEH-60A Quick Fix configured helicopter consists of the Quick Fix System and the following equipment: the AN/APR-39 Radar Signal Detecting Set, the AN/ALQ-144(V) Infrared (IR) Countermeasures Set, two M-130 Chaff/Flare Dispensers, cruise engine exhaust IR suppressors (FSN 1560-01-125-9454), and the AN/ASN-132 Integrated Inertial Navigation System (IINS). During this evaluation a mockup of the AN/ALQ-144(V) IR Countermeasures Set was used. A more detailed description of the UH-60A is contained in the operator's manual (ref 2, app A). Additional information for the Quick Fix System is contained in the draft supplemental instructions for the YEH-60A (ref 3), and appendix B.

#### TEST SCOPE

4. The limited A&FC test was conducted at Edwards Air Force Base, California (elevation 2302 ft). Eighteen flights totaling 12.4 productive flight hours were conducted between 23 May and 27 June 1984. The US Army Development Test Activity, Fort Rucker, Alabama provided aircraft maintenance during the instrumentation and maintenance check flight phases of the program. USAAEFA installed, calibrated, and maintained all instrumentation and was responsible for aircraft maintenance beginning 18 May 1984.

5. The aircraft was operated within the limits of the operator's manual, the Quick Fix supplemental instructions, and the airworthiness release (ref 4, app A) issued by AVSCOM. Testing was conducted in accordance with the test plan (ref 5). Flight test conditions are shown in table 1. Handling qualities tests were flown with the ECM antenna both extended and retracted and the results evaluated with respect to the applicable requirements of MIL-H-8501A (ref 6) and attachment 2 to contract DAAJ09-82-C-A326 Prime Item Development Specification (PIDS) (ref 7). Performance data were compared with previous test results of the normal utility configured UH-60A helicopter (ref 8).

#### TEST METHODOLOGY

6. Handling qualities tests were conducted in accordance with flight test techniques described in reference 9, appendix A. Qualitative handling qualities were also assessed during ferry flights and icing tests in conjunction with another test project (ref 10). Performance tests were conducted in accordance with reference 11. Flight test data were hand-recorded from standard ship and sensitive calibrated cockpit instruments as well as

Table 1. Flight Test Conditions<sup>1</sup>

Type of Test	Average Gross Weight (lb)	Average Longitudinal Center of Gravity (FS)	Average Density Altitude (ft)	Calibrated Airspeed (kt)
Level Flight <sup>2</sup>	15,970	359.3 <sup>3</sup>	7170 to 15,690	52 to 154 KTAS <sup>4</sup>
Control Positions in Trimmed Forward Flight	15,630	359.0	7300	40-176
Static Longitudinal Stability	15,670	359.2	7570	81 and 127
Static Lateral-Directional Stability	15,680	359.2	7270	81 and 127
Maneuvering Stability	16,050	359.8	8470	83 and 120
Dynamic Stability	15,830	359.8	7230	83 and 127
Low-Speed Flight Characteristics	15,870	360.4	2260	0 to 51 KTAS

NOTES:

<sup>1</sup>YEH-60A Quick Fix configuration with the retractable ECM antenna extended, lateral center of gravity (cg) at a butt line (BL) of 0.3 left, Automatic Flight Control System (AFCS) ON, and 100 percent main rotor speed, unless otherwise noted.

Handling qualities were evaluated in icing and other conditions throughout the flight envelope with the ECM antenna extended and retracted.

<sup>2</sup>Conducted at a referred rotor speed ( $N_R/\sqrt{\theta}$ ) of 258 RPM

<sup>3</sup>CG range at 16,000 pounds is 345.6 to 364.4

<sup>4</sup>KTAS: knots true airspeed

sensitive calibrated instruments mounted at the ECM operator's station. Rotor speed was measured at the swashplate and the signal telemetered to a ground receiver for accurate rotor speed determination. A detailed listing of the test instrumentation is contained in appendix C. Test techniques and data analysis methods are described in appendix D. Pilot comments were used to aid in the analysis of the data and to determine the overall assessment of the flying qualities of the YEH-60A Quick Fix configuration. A Handling Qualities Rating Scale (HQRS) (fig. 1, app D) was used to augment pilot comments relative to handling qualities.

# RESULTS AND DISCUSSION

## GENERAL

7. The evaluation was conducted to determine the effects of the installation of the AN/ALQ-151(V)2 countermeasures system and associated mission equipment on a UH-60A helicopter. The addition of the Quick Fix System and associated mission equipment created an increase in equivalent flat plate area ( $F_e$ ) of 17 square feet ( $\text{ft}^2$ ) for advance ratios ( $\mu$ ) of 0.26 and greater. For  $\mu$ 's less than 0.26, the change in  $F_e$  ( $\Delta F_e$ ) increased above 17  $\text{ft}^2$  as a function of thrust coefficient ( $C_T$ ). The handling qualities of the YEH-60A Quick Fix configured helicopter were unchanged from a normal utility configured UH-60A and were satisfactory. One deficiency, interference between the main rotor blades and the upper elements of the aft (#3 and #4) DF dipole antennas during ground taxi, and four shortcomings are associated with the Quick Fix configuration. One additional deficiency and one additional shortcoming exist that were previously identified in reference 8, appendix A. The remainder of the deficiencies and shortcomings identified in reference 8 were not specifically reevaluated during this test.

## LEVEL FLIGHT PERFORMANCE

8. Level flight performance tests were conducted at the conditions listed in table 1 to determine power required and fuel flow of the YEH-60A at various airspeeds. The aircraft was tested at a longitudinal cg of fuselage station (FS) 359. Previous level flight performance testing in the normal utility configuration was conducted primarily at a cg of FS 347. A longitudinal cg of FS 359 was the alternate cg tested during the previous evaluation and a difference of 2  $\text{ft}^2$  of  $F_e$  was determined between the two cg configurations. Testing at a longitudinal cg of FS 359 closely reflects the YEH-60A mission configuration. Techniques used in obtaining and analyzing level flight performance data are described in detail in appendix D. The aircraft was flown in ball-centered flight and the data were converted to a zero sideslip trim condition for comparison to the normal utility configured UH-60A, reference 8, appendix A. All performance data were corrected for estimated drag of external test instrumentation and instrumentation electrical load. Mission equipment was not operated during level flight performance tests.

9. The increase in  $F_e$  of the YEH-60A Quick Fix configuration in comparison with the UH-60A normal utility configuration is presented in figure 1, appendix E. The  $\Delta F_e$  of 17  $\text{ft}^2$  depicted for  $\mu$  of 0.26 and greater was not valid at lower  $\mu$ 's, and if used, would indicate less power than actually required. The data indicate that below a  $\mu$  of 0.26 the  $\Delta F_e$  increased

above 17 ft<sup>2</sup> with increasing  $C_T$  and decreasing  $\mu$ , a trend substantiated in reference 8, appendix A, by two of three level flight performance tests flown with IR suppressors installed indicating more power required than characterized by a constant  $\Delta F_e$  at low airspeeds. The results of incorporating  $\Delta F_e$  from figure 1 with the UH-60A nondimensional family of curves for the  $C_T$ 's flown during this evaluation, referenced to  $N/\sqrt{\theta}$  of 258 and zero sideslip trim conditions, are presented in figures 2 through 5. Nondimensional test results representing power required for the YEH-60A in ball-centered level flight are presented in figures 6 through 8. Dimensional level flight test results are presented in figures 9 through 12.

## HANDLING QUALITIES

### Control Positions in Trimmed Forward Flight

10. Control positions in trimmed forward flight were evaluated at the conditions listed in table 1. Data were obtained by stabilizing in ball-centered level flight in 10 knot increments and trimming control forces to zero. At airspeeds greater than 60 knots calibrated airspeed (KCAS), the variation of longitudinal control position with airspeed was essentially linear, with increased forward cyclic required for increased trim airspeed. For all airspeeds, increased right lateral cyclic was required with increased trim airspeed. The control positions of the Quick Fix configured YEH-60A in trimmed level flight are similar to a normal utility configured UH-60A and are satisfactory.

11. With the trim system engaged, the right pedal would slowly move forward requiring increased foot pressure on the left pedal to maintain trimmed forward flight. The movement could be stopped by turning the flight path stability (FPS) system off or by depressing the trim release switch. As a result of the pedal movement, the pilot found the aircraft was always "out-of-trim" whenever he was not concentrating on this specific task. The Quick Fix mission requires extended periods of flat turns conducted at constant turn rates to accurately locate emitters and conduct countermeasures operations. The uncommanded directional control input in trimmed flight will significantly increase pilot workload and fatigue during mission maneuvers and in IMC which is a deficiency previously reported in reference 8, appendix A. The directional control trim system failed to meet the requirements of paragraph 10.3.2.5 of the PIDS in that zero control force could not be maintained.

### Static Longitudinal Stability

12. The collective fixed static longitudinal stability was evaluated in level flight at the conditions shown in table 1. The IINS provided heading and attitude information to the ship's Stability Augmentation System (SAS)/FPS computer. The evaluation was performed by trimming the aircraft in ball-centered flight through the use of a sensitive lateral accelerometer at the desired airspeeds. With the collective control held fixed and without retrimming, the aircraft was stabilized at incremental higher and lower airspeeds. Static longitudinal stability was neutral to positive. Positive stability was indicated by increased forward longitudinal control required to maintain an airspeed greater than trim airspeed. The Quick Fix configured YEH-60A static longitudinal stability characteristics are similar to a normal utility configured UH-60A and are satisfactory.

### Static Lateral-Directional Stability

13. The static lateral-directional stability was evaluated in level flight at the conditions shown in table 1. The IINS provided attitude and heading information to the SAS/FPS computer during these tests. The evaluation was performed by first trimming the aircraft in ball-centered flight at the desired airspeed, then, while maintaining a fixed collective position and a constant ground track, the aircraft was stabilized at increasing incremental out-of-trim conditions both left and right. The out-of-trim flight condition was determined using a sensitive lateral accelerometer with sideslip monitored at the engineer station. Apparent static directional stability, as indicated by the variation of directional control position with sideslip, was positive. Increased left directional control was required with increased right sideslip. Dihedral effect, as indicated by the variation of lateral control position with sideslip, was positive. Increased right cyclic control was required with increased right sideslip. The sideforce characteristics, as indicated by the variation of bank angle with sideslip, were positive. Increased right bank angle was required with increased right sideslip. The static lateral-directional characteristics of the Quick Fix configured YEH-60A are similar to those of the normal utility configured UH-60A and are satisfactory.

### Maneuvering Stability

14. Maneuvering stability was evaluated in coordinated ball-centered left and right turns at the conditions shown in table 1. The helicopter was trimmed in level flight at the test airspeeds with the IINS providing heading and attitude information to the

SAS/FPS computer. Load factor was increased by stabilizing the helicopter at increasing bank angles in left and right turns. Airspeed and collective were maintained constant while altitude was allowed to vary. The maneuvering stability, as indicated by the variation of longitudinal control position with normal acceleration (g), was positive up to bank angles of 45 degrees (approximately 1.4g). Increasing aft cyclic was required for increasing normal acceleration. Beyond 45 degrees of bank, maneuvering stability became neutral to negative, small continuous longitudinal control inputs were required and airspeed could only be maintained within +3 knots (HQRS 6 to 7). The maneuvering stability of the YEH-60A failed to meet the requirements of paragraphs 10.3.3.1.4 and 10.3.3.1.4.1 of the PIDS in that positive stick fixed or stick free stability was not exhibited in steady turning flight. Maneuvering stability characteristics of the Quick Fix configured YEH-60A are similar to those of a normal utility configured UH-60A.

#### Dynamic Stability

15. Dynamic stability was evaluated in level flight at the conditions shown in table 1. Short-term dynamic stability was evaluated following abrupt pulse inputs about the longitudinal, lateral, and directional axes. All controls other than the input control remained fixed during the test. The IINS provided attitude and heading information to the SAS/FPS computer. All short-term responses were essentially deadbeat. Long-term dynamic response was evaluated by slowing the aircraft with aft cyclic control to an airspeed 10 knots below trim airspeed, then returning the control to the trim position and holding it fixed. The pilot applied lateral and directional control inputs as necessary to obtain a single axis response. Long-term longitudinal response was essentially deadbeat. Dynamic lateral-directional stability was also evaluated by releases from steady heading sideslips. The aircraft response was a heavily damped oscillation with one overshoot. The ECM antenna was extended and retracted during climbing, diving, and level flight at representative airspeeds throughout the flight envelope. Extension or retraction of the antenna did not affect aircraft handling qualities and antenna movement was not apparent to the crew. The dynamic stability characteristics of the Quick Fix configured YEH-60A are similar to those of a normal utility configured UH-60A and are satisfactory.

### Ground Handling Characteristics

#### Pitch Oscillation During Ground Taxi:

16. During ground taxi on a level, hard surface with collective settings sufficient for the aircraft to be "light" on its wheels, a self exciting aircraft pitch oscillation was experienced. The oscillation was neutrally damped and would stop when the collective was lowered. The amplitude of the oscillation was significantly reduced with both SAS's OFF. The pitch oscillation was more frequently observed at the completion of a flight with less weight over the tail wheel due to fuel burnoff. Exposing the electronic equipment of the AN/ALQ-151(V)2 countermeasures system to the vibrations caused by this pitch oscillation could accelerate wear or cause damage. The aircraft pitch oscillation during ground taxi is a shortcoming previously reported in reference 8, appendix A.

#### DF Antenna/Main Rotor Clearance:

17. During previous testing (ref 10, app A), one main rotor blade contacted the upper elements of the #3 and #4 DF antennas while the aircraft was being ground taxied rearward. The top two inches of each antenna element were severed, the element attachment phenolic blocks damaged, and the tail rotor drive shaft cover punctured by an antenna fragment. No corrective action was implemented for this deficiency and no specific evaluation was accomplished during this test to investigate it further. The interference between the main rotor blades and the upper elements of the aft (#3 and #4) DF dipole antennas during rearward ground taxi is a deficiency.

### Low-Speed Flight Characteristics

18. The handling qualities of the YEH-60A helicopter during low-speed flight were evaluated at the conditions shown in table 1. Data were obtained by stabilizing the aircraft 25 feet above ground at airspeed increments in sideward, rearward and forward flight utilizing a ground pace vehicle as a speed reference. The IINS was the source of attitude and heading information to the SAS/FPS computer throughout the evaluation. The variation of longitudinal control position with airspeed in low-speed rearward and forward flight was conventional and satisfactory. Increased aft longitudinal control was required with increased rearward airspeed. The variation of lateral control position with airspeed in low-speed left and right sideward flight was conventional. Increased right lateral control was required with increased right sideward airspeed. Control excursions and pilot

workload were highest at approximately 20 knots when passing through translational lift. Control margins in all azimuths tested were in excess of 10 percent. The handling qualities of the Quick Fix configured YEH-60A in low-speed flight are similar to those of the UH-60A configured with the cruise engine exhaust IR suppressors.

#### HUMAN FACTORS

##### ECM Antenna Advisory Light

19. During an approach to landing with the ECM antenna in the extended position, the antenna contacted the ground and was damaged. The automatic antenna retraction provision had been disabled by setting the LO altitude bug of the radar altimeter to 0 feet while performing low-speed flight tests at 25 feet. With the automatic antenna retraction provision disabled, the pilot received no positive indication that the ECM antenna was extended. This shortcoming was previously reported (ref 10, app A). The lack of an ECM ANTENNA EXTENDED advisory light in the cockpit independent of the radar altimeter setting is a shortcoming.

##### Miscellaneous

20. The following two previously identified shortcomings (ref 10, app A) of the Quick Fix configured YEH-60A still remain:

a. The excessively long and complicated normal alignment procedures required for the AN/ASN-132 IINS system.

b. The poor location of the emergency ECM antenna retract switch.

#### RELIABILITY AND MAINTAINABILITY

##### AN/ASN-132 IINS

21. During this program one IINS failure occurred. The Navigation Processor Unit (NPU) failed and required reprogramming by the manufacturer. The reprogramming was accomplished in 2 hours by personnel using specialized equipment. A new model Cockpit Display Unit (CDU) was installed in the aircraft on 13 June 1984. This unit was designed to protect the IINS from power transients during the hydraulic leak test. These power transients are caused by the cycling of the electrically driven backup hydraulic pump.

The new CDU was tested by USAAEFA for 10 days and no NPU failures were experienced.

AN/ALQ-144(V) IR Countermeasure Set

22. During preflight inspection, the crew noticed that when the right door of the Auxiliary Power Unit (APU) compartment was opened, it rubbed against the power assembly harness (FSN 70552-02112-041) of the AN/ALQ-144(V) wearing away the harness insulation. To prevent further deterioration of the wiring, the harness was covered with plastic anti-chaffing material for the remainder of the test. The chaffing of the AN/ALQ-144(V) IR Countermeasure Set power assembly harness caused by contact with the right door of the APU compartment is a shortcoming.

# CONCLUSIONS

## GENERAL

23. Based on the limited A&FC evaluation the following conclusions relating to the YEH-60A Quick Fix configuration were made:

a. The installation of the AN/ALQ-151(V)2 countermeasure system and related mission equipment on a normal utility configured UH-60A created an increase in  $F_e$  of 17 ft<sup>2</sup> for  $\mu$ 's of 0.26 and greater. For  $\mu$ 's of less than 0.26,  $\Delta F_e$  increased above 17 ft<sup>2</sup> as a function of  $C_T$ .

b. The Quick Fix configured YEH-60A handling qualities were similar to those of a normal utility configured UH-60A.

c. One deficiency and four shortcomings are associated with the Quick Fix configuration. One deficiency, one shortcoming, and two PIDS noncompliances exist that were previously identified. The remainder of the previously identified deficiencies, shortcomings, and PIDS noncompliance items were not specifically reevaluated during this test.

## DEFICIENCIES

24. The deficiency attributable to the Quick Fix configuration was the interference between the main rotor blades and the upper elements of the aft (#3 and #4) DF dipole antennas during ground taxi (para 17).

25. The previously identified aircraft deficiency, which detracts from Quick Fix mission effectiveness, was the uncommanded directional control input in trimmed flight (para 11).

## SHORTCOMINGS

26. The following shortcomings attributable to the Quick Fix configuration were identified and are listed in order of decreasing importance:

a. The lack of an ECM ANTENNA EXTENDED advisory light in the cockpit independent of radar altimeter setting (para 19).

b. The excessively long and complicated normal alignment procedures required for the AN/ASN-132 IINS system (para 20).

c. The poor location of the emergency ECM antenna retract switch (para 20).

d. The chaffing of the AN/ALQ-144(V) power assembly harness caused by contact with the right door of the APU compartment (para 22).

27. The previously identified aircraft shortcoming, which detracts from Quick Fix mission effectiveness, was the aircraft pitch oscillation during ground taxi (para 16).

#### SPECIFICATION COMPLIANCE

28. The Quick Fix configured YEH-60A failed to meet the following requirements of the PIDS, however, the noncompliances are not associated with the installation of the Quick Fix System:

a. Paragraph 10.3.2.5 - The directional control trim system would not maintain a zero control force (para 11).

b. Paragraph 10.3.3.1.4 and 10.3.3.1.4.1 - Positive stick fixed or stick free maneuvering stability was not exhibited in steady turning flight (para 14).

## RECOMMENDATIONS

29. The following recommendations are made:

a. The deficiency in paragraph 24 should be corrected prior to production.

b. The remaining deficiency (para 25) and the shortcomings listed in paragraphs 26 and 27 should be corrected.

## APPENDIX A. REFERENCES

1. Letter, AVSCOM, DRDAV-DI, 6 September 1983, subject: Airworthiness and Flight Characteristics (A&FC) Test of the YEH-60A Quick Fix System.
2. Technical Manual, TM 55-1520-237-10, *Operator's Manual, UH-60A Helicopter*, 21 May 1979 with change 24 dated 23 March 1984.
3. Technical Manual, TM 55-1520-237-10-1, *Draft Supplemental Instructions, YEH-60A Helicopter*, 15 March 1982.
4. Letter, AVSCOM, DRSAB-E, 17 April 1984 and 28 April 1984, subject: Airworthiness Release for YEH-60A Helicopter S/N 79-23301 to Conduct Limited Airworthiness and Flight Characteristics (A&FC) and Vibration Survey of the YEH-60A Quick Fix System, USAAEFA Project No. 83-20.
5. Test Plan, USAAEFA Project No. 83-20, *Limited Airworthiness and Flight Characteristics (A&FC) Test and Vibration Survey of the YEH-60A Quick Fix System*, November 1983.
6. Military Specification, MIL-H-8501A, *Helicopter Flying and Ground Handling Qualities General Requirements for*, 7 September 1961, with Amendment 1, 3 April 1962.
7. Prime Item Development Specification, Sikorsky Aircraft Division, DARCOM-CP-2222-S1000F, Part 1, 18 December 1981.
8. Final Report, USAAEFA Project No. 77-17, *Airworthiness and Flight Characteristics Evaluation, UH-60A (Black Hawk) Helicopter*, September 1981.
9. Flight Test Manual, Naval Air Test Center, FTM No. 101, *Helicopter Stability and Control*, 10 June 1968.
10. Final Report, USAAEFA Project No. 83-21, *Artificial and Natural Icing Tests YEH-60A Quick Fix Helicopter*, Unpublished.
11. Engineering Design Handbook, Army Material Command, AMCP 706-204, *Helicopter Performance Testing*, August 1974.
12. Final Report, USAAEFA Project No. 83-24, *Airworthiness and Flight Characteristics Test of a Sixth Production UH-60A (Black Hawk) Helicopter*, Unpublished.

## APPENDIX B. DESCRIPTION

### GENERAL

1. The test helicopter, US Army S/N 79-23301, is a normal utility configured UH-60A helicopter modified to accept an AN/ALQ-151(V)2 countermeasures system designated the Quick Fix System. The external modifications required for the AN/ALQ-151(V)2 countermeasures system include the addition of two Ultra High Frequency antennas and one Tactical Air Navigation (TACAN) antenna on the underside of the fuselage, the removal of the Doppler antenna from the underside of the fuselage under the copilot's seat, the installation of a retractable Electronics Countermeasures (ECM) antenna on the underside of the fuselage forward of the transition section, and the mounting of a Direction Finding (DF) dipole antenna set on the tailcone exterior (photos 1 through 4 and fig. 1). The Quick Fix configured helicopter, designated YEH-60A, is also equipped with the AN/APR-39 Radar Signal Detecting Set, the AN/ALQ-144(V) Infrared (IR) Countermeasures Set, the AN/ASN-132 Integrated Inertial Navigation System (IINS), built-in test equipment located in the rear vertical section of the tail rotor pylon, cruise engine exhaust IR suppressors (FSN 1560-01-125-9454), and two M-130 chaff/flare dispensers mounted on the left side of the tailcone. Mission electronic equipment is mounted in the cabin area and controlled by two operators. Cockpit instruments and controls allow the pilot/copilot to control the ECM antenna position, conduct secure voice transmission, and interface with the mission equipment operators. Principle dimensions and features of the YEH-60A Quick Fix are presented in the operator's manual (ref 2, app A) and the draft supplemental instructions (ref 3). A complete deicing kit was installed. This kit incorporated main and tail rotor deicing, an ice detection and anti-icing system for the pilot and copilot windshields, pitot-static tubes and their support struts, engine, and engine inlets. The test helicopter was equipped with improved main rotor droop stops (FSN 70105-08151-045).

### DF ANTENNAS

2. The YEH-60A was equipped with a DF dipole antenna set consisting of four antennas mounted on the tailcone exterior. Two antennas were mounted on each side of the tailcone at fuselage stations (FS's) 536.0 left and right and 596.6 left and right. Each antenna consisted of two monopole antenna elements; each antenna was 40.5 inches long and constructed from 1 inch diameter, 0.080 inch thick hollow aluminum tubing. These monopole elements were attached to phenolic blocks and mounted to the tailcone with a horizontal brace (photo 5). The antenna positions were numbered clockwise with the front left antenna labeled antenna #1.

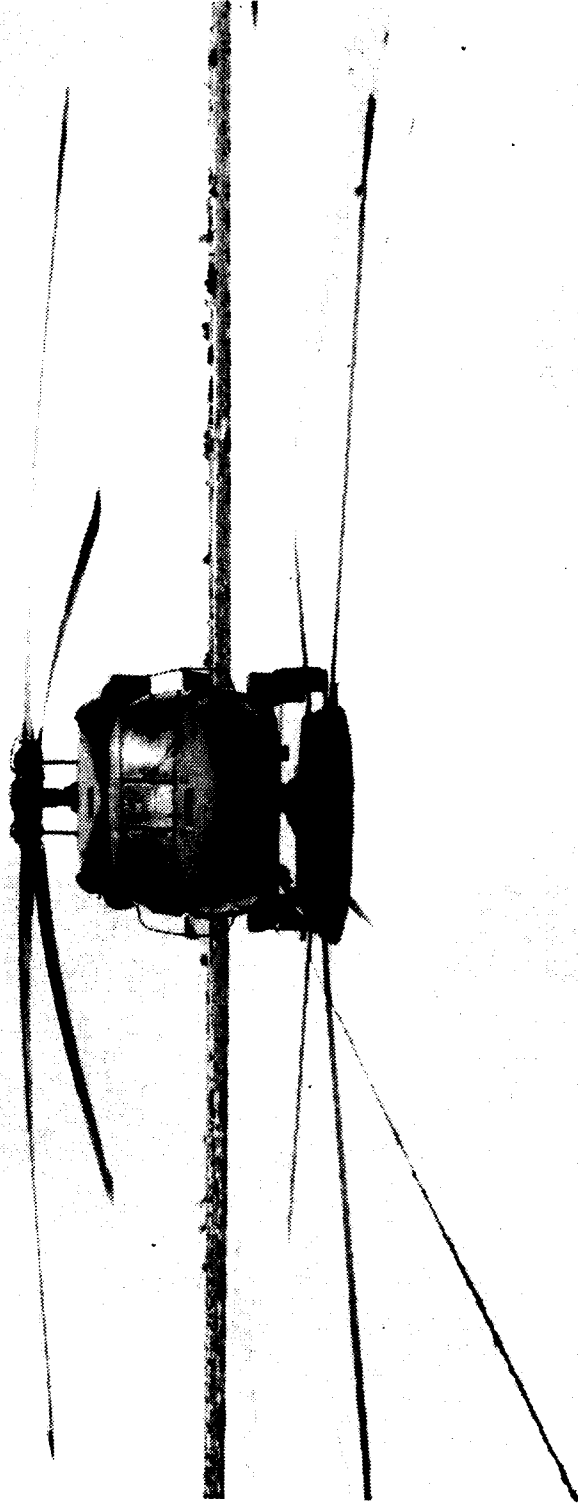

Photo 1. YE-H-60A Front View

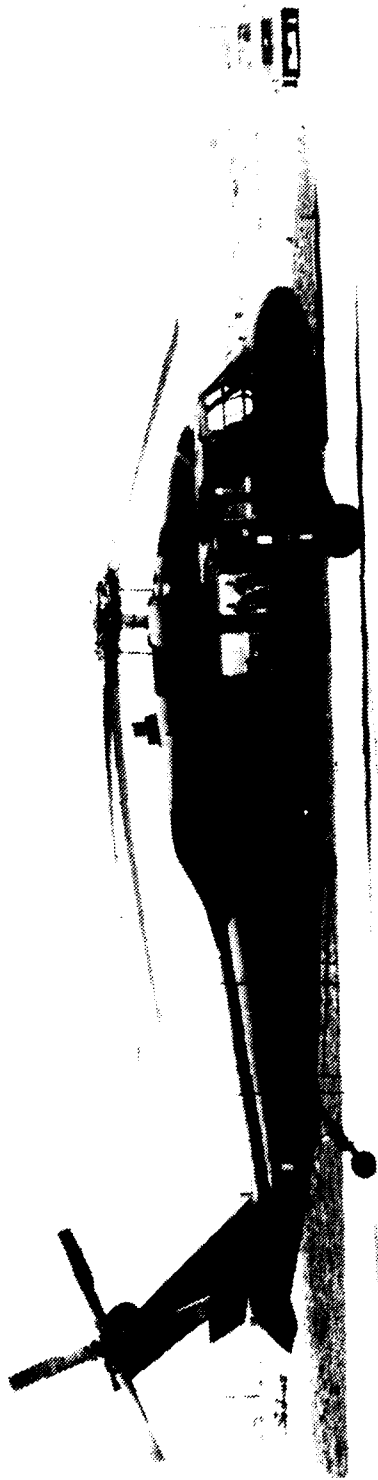

Photo 2. YEH-60A Right Side View

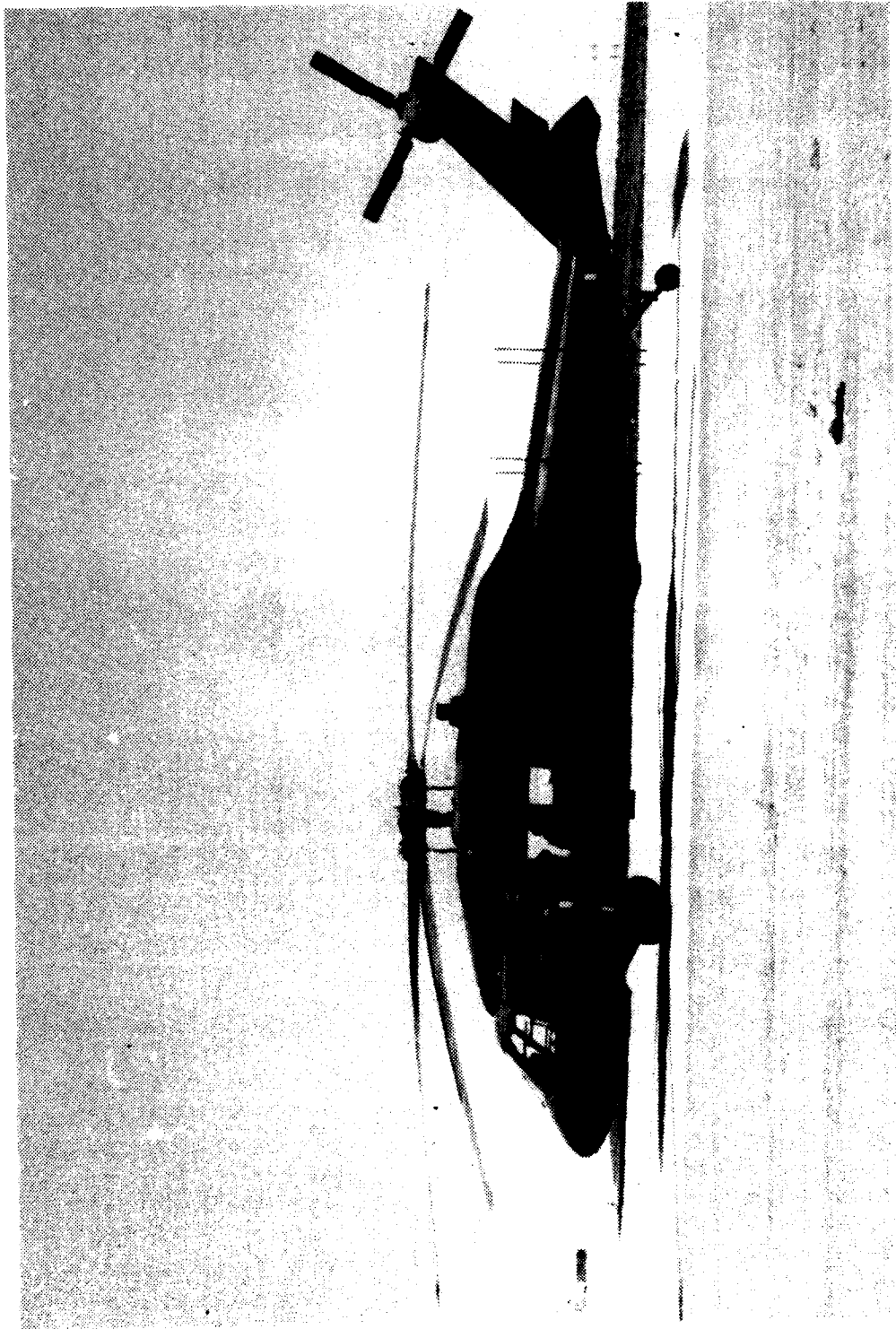

Photo 3. YEH-60A Left Side View

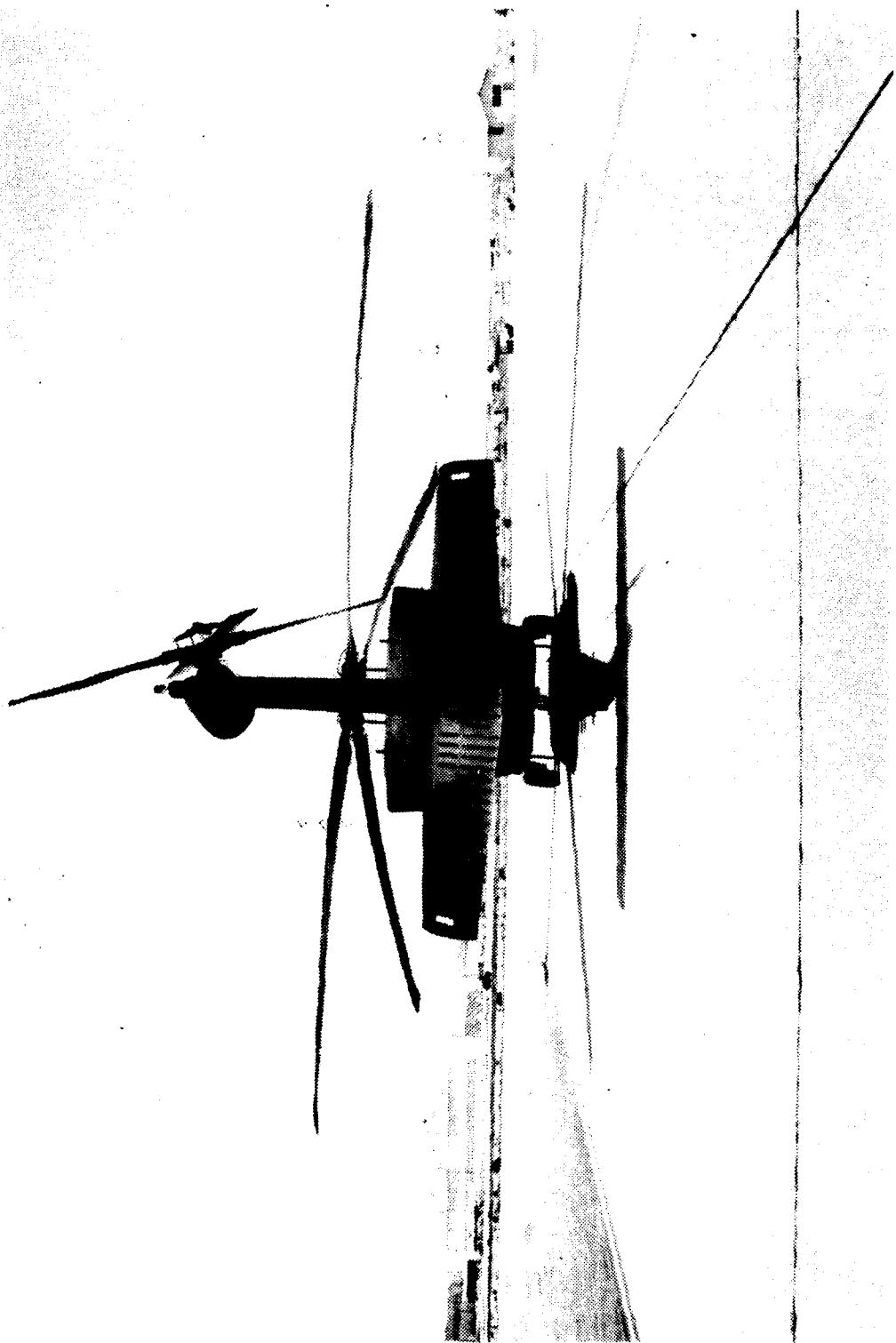

Photo 4. YEH-60A Rear View

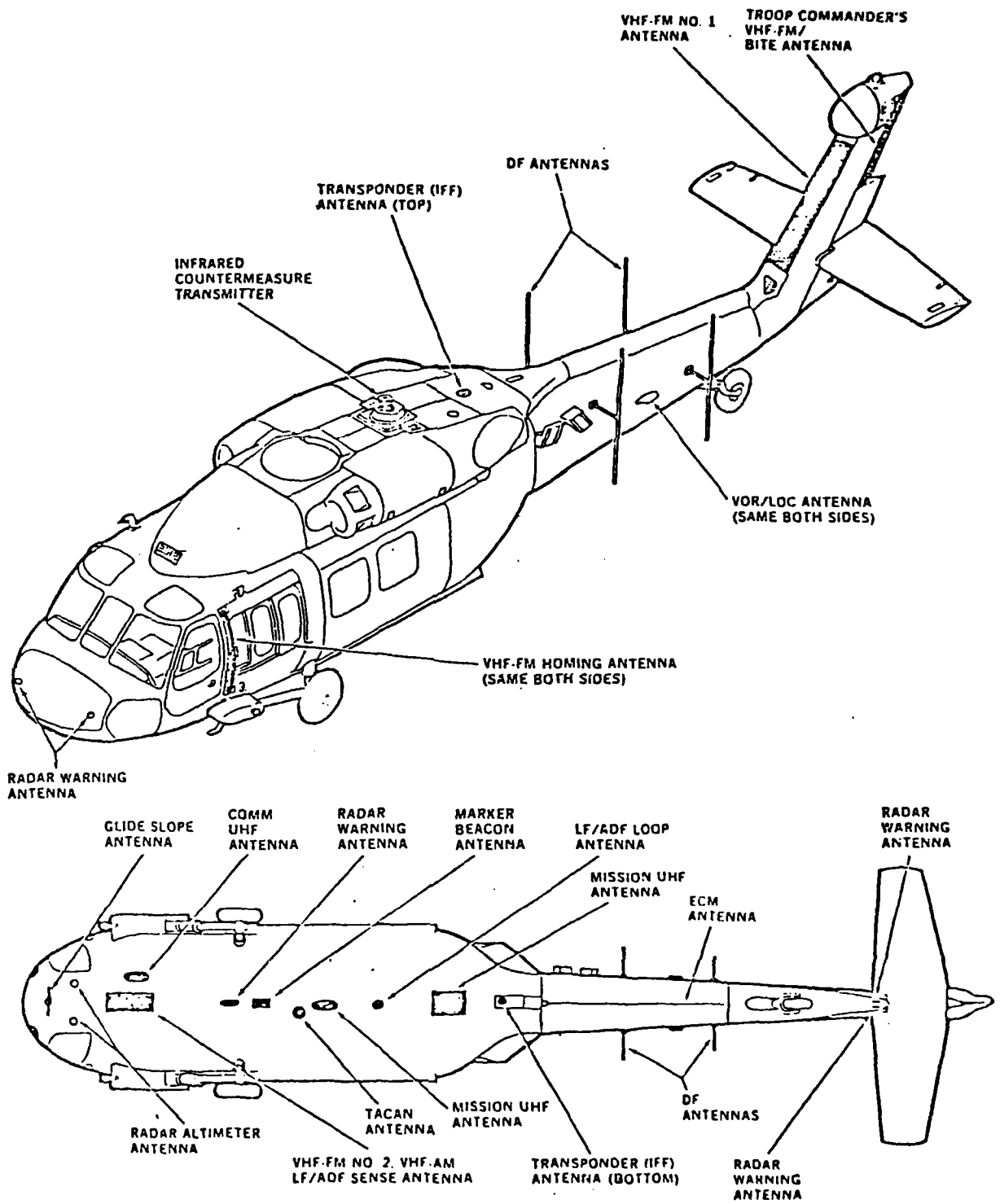

Figure 1. YEH-60A Antennas

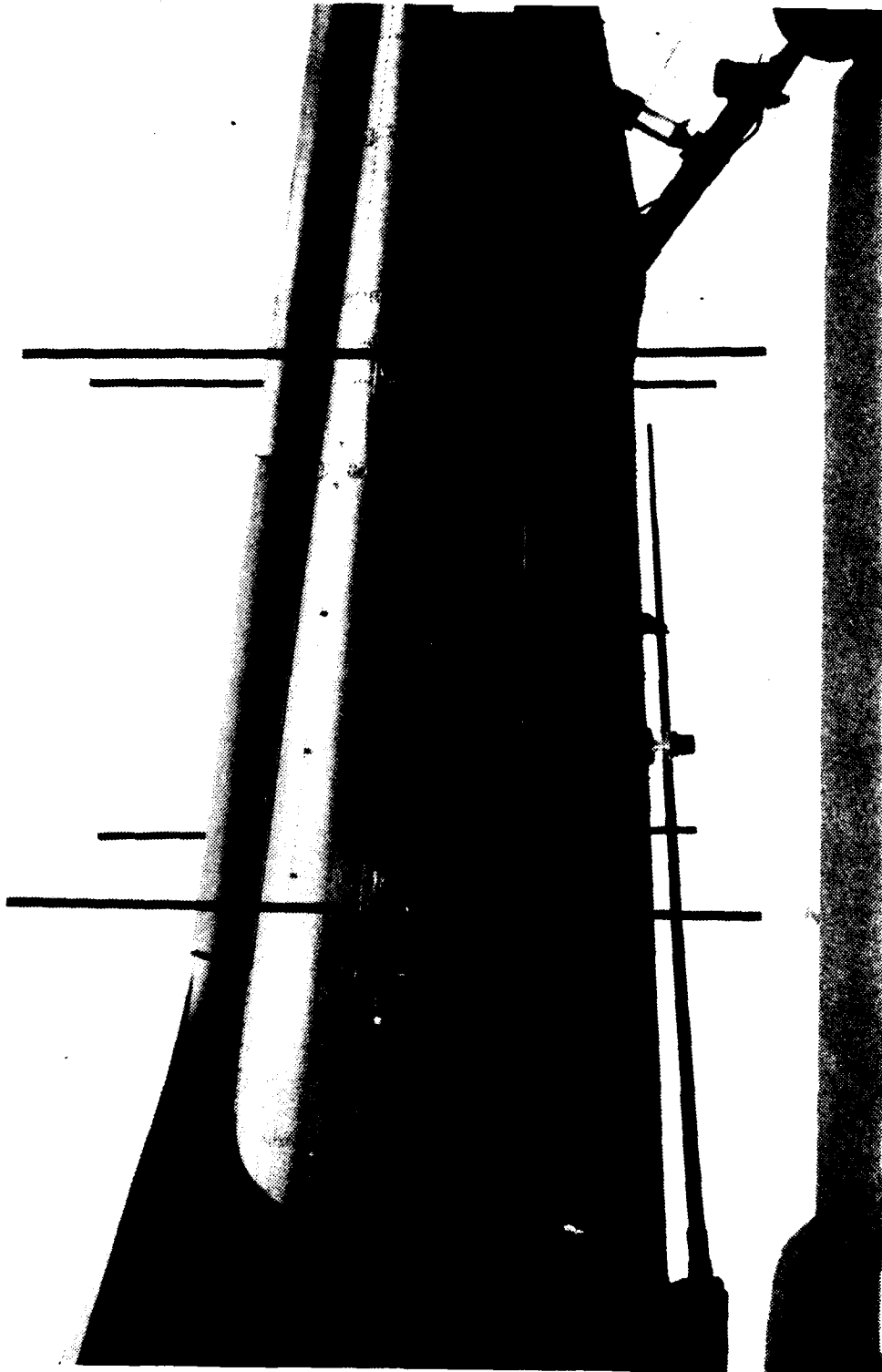

Photo 5. Direction Finding (DF) Antenna Set and Electronic Countermeasures (ECM) Antenna - Retracted

All electrical wiring was routed internally through the horizontal braces and the tailcone.

#### ECM ANTENNA

3. The ECM antenna is an eight pound, 109 inch long monopole antenna mounted on the fuselage just forward of the tailcone assembly at FS 483 (photo 5). Constructed of 1/8 inch thick hollow aluminum tubing, its' diameter tapers from 3.0 inches at its base to 0.50 inches at the tip. The ECM antenna rotates downward and forward pivoting about the base mounting structure to extend (photo 6). Power for ECM antenna extension is provided by an electronic actuator controlled by a three-position guarded switch on the center instrument panel (fig. 2). The ECM antenna will automatically retract whenever the copilot's radar altimeter is turned on and the aircraft's absolute altitude becomes less than the value selected on his LO altitude bug indicator. Whenever the ECM antenna is fully retracted, the ANTENNA RETRACTED status advisory light on the caution/advisory panel will go on and remain on. When the antenna is fully extended, a light on the ECM operator's console marked ANTENNA DEPLOYED will go on and remain illuminated until the antenna is fully retracted. The ANTENNA EXTENDED caution light on the caution/advisory panel is designed to remain illuminated whenever the antenna is not fully retracted and at least one of the following conditions exist: (1) the helicopter is below the radar altimeter LO altitude bug setting, (2) power is lost, or (3) the radar altimeter is turned off or removed.

#### MISSION EQUIPMENT

##### AN/ALQ-151(V)2

4. The AN/ALQ-151(V)2 countermeasures system is designed to detect radiated radio frequency signals, automatically referencing the location of the transmitter, and initiating active countermeasures against the emitter. The system consists of six subsystems: direction finder group, intercept group, communications group, computer/navigation group, active countermeasures group (AN/TLO-17A), and system power group. The electronic surveillance measures (ESM) equipment and the ECM equipment operate independently of each other. The ESM operator controls the electronic surveillance functions and the ECM operator controls the active countermeasures functions. These operations interface via the system intercommunications network. The majority of the equipment is housed in the cargo compartment, as

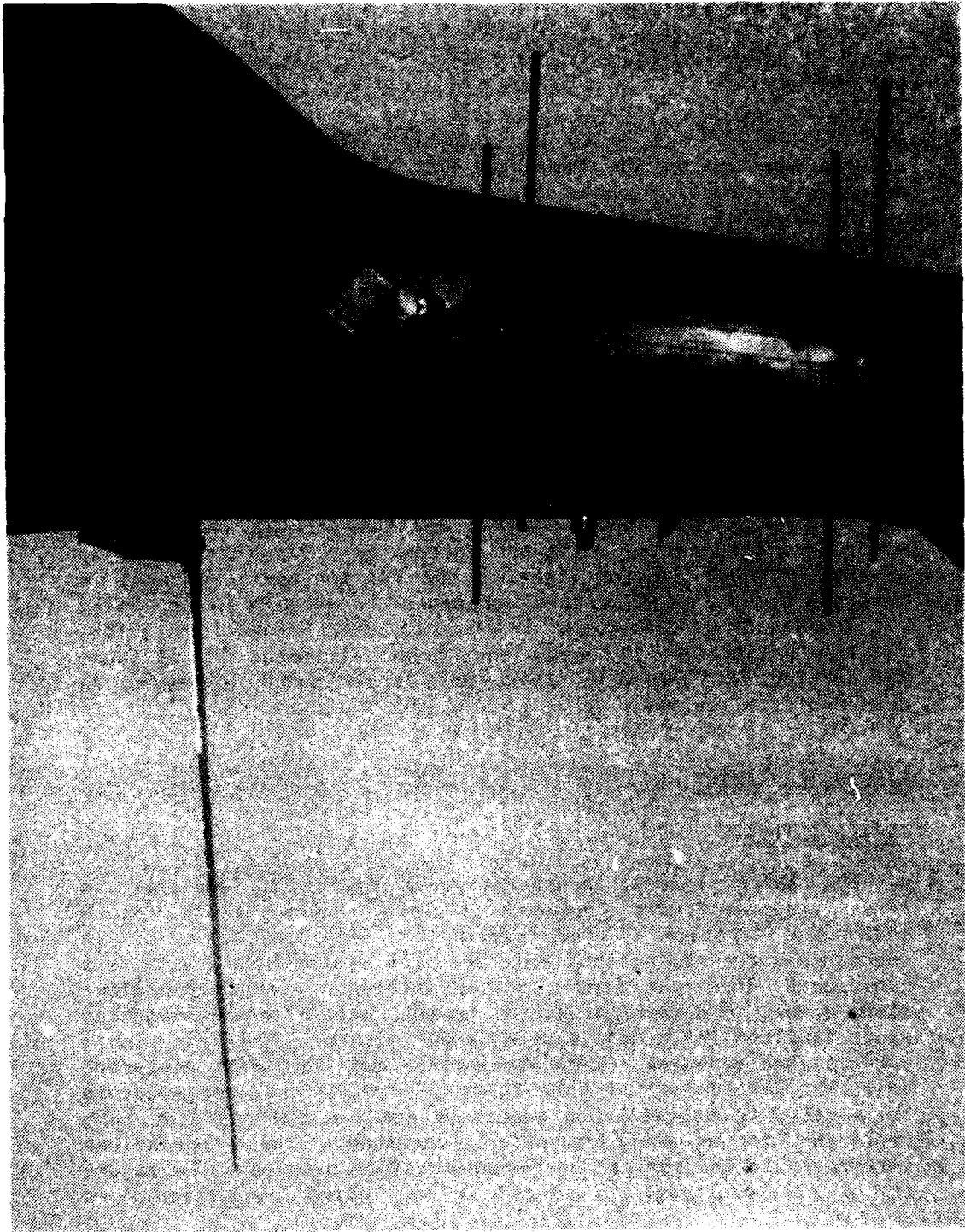

Photo 6. ECM Antenna - Extended

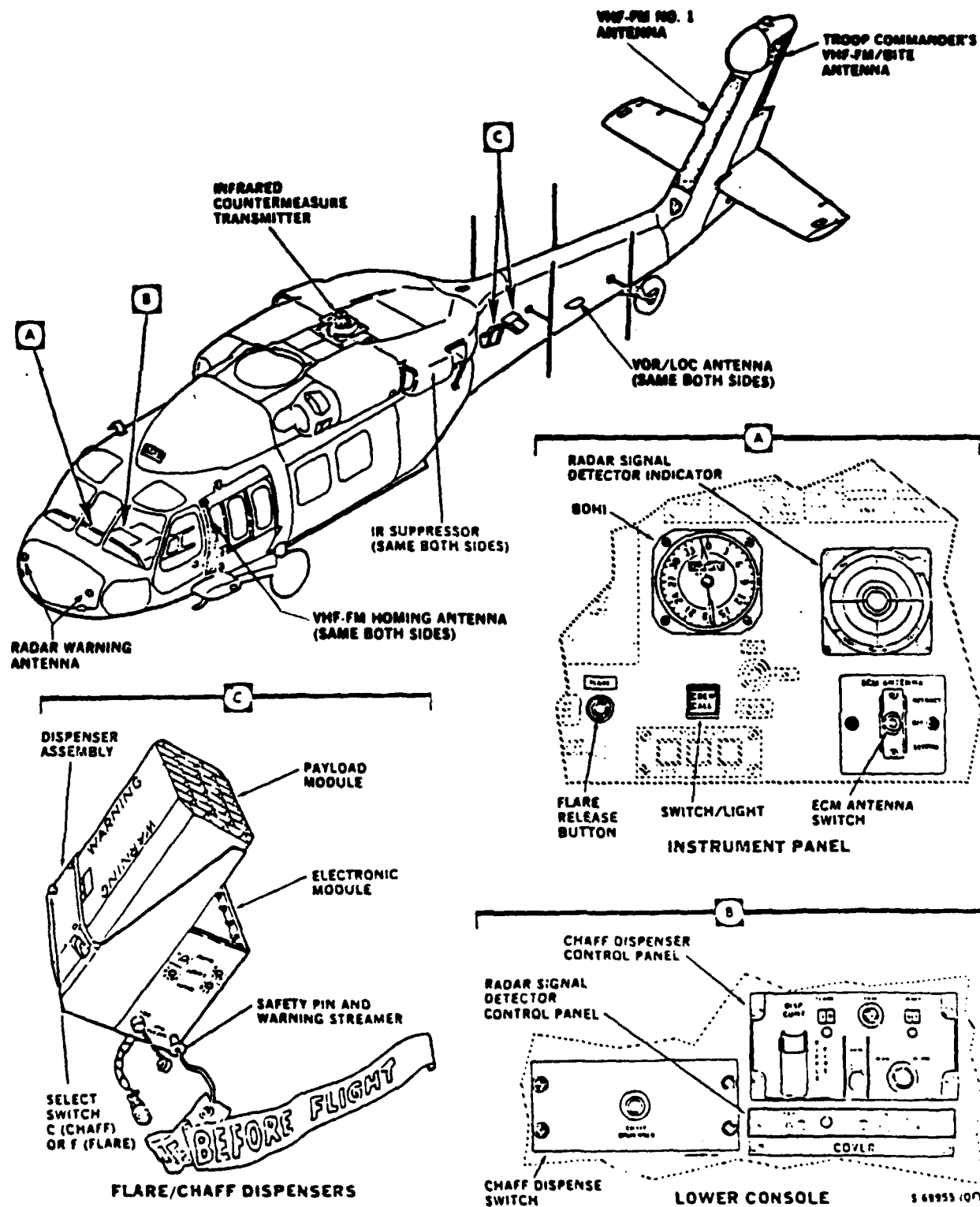

Figure 2. YEH-60A Mission Kits (Exclusive of Cabin Areas)

shown in figure 3. Additional equipment is located in the tail, tailcone, nose, and cockpit.

### AN/ASN-132 IINS

#### General

5. The AN/ASN-132 IINS is designed to provide self-contained, world-wide position and navigation information which can be automatically updated wherever TACAN facilities exist or manually updated without TACAN data. The IINS uses a gyro-stabilized, four-gimbal, all-attitude platform to measure aircraft acceleration and provide present-position and velocity data, course-line information, steering commands, and angular pitch, roll, and heading information.

#### IINS Interface

6. The AN/ASN-132 Control and Display Unit (CDU) contains the IINS operating controls and indicators and is mounted on the lower center console (photo 7). The CDU enables the operator to enter data and control the information displayed on the cathode ray tube. In addition to providing navigation information, the IINS is interfaced with the aircraft flight instruments and altimeter/encoder AAU-32A as outlined in figure 4. The attitude gyroscope (CN-1314) outputs, which supply pitch and roll inputs to the Automatic Flight Control System (AFCS) for the normal utility configured UH-60A, are replaced by appropriate outputs from the IINS. Heading information from the IINS also replaced the aircraft's AN/ASN-43 compass inputs to the AFCS. A bank of three switches provides the capability to select either IINS or standard helicopter information inputs to the AFCS.

#### Chaff/Flare Dispenser (M-130) System

7. The YEH-60A is equipped with two M-130 General Purpose Dispensers and is designed to provide survival countermeasures against radar guided weapons and IR seeking missiles. The systems are mounted on the left side of the tailcone (photo 8) and consist of two dispenser assemblies, payload modules, and electronic modules. The dispenser control panel and chaff dispense pushbutton are mounted on the lower console (fig. 2). The flare dispense pushbutton is mounted on the instrument panel.

#### IR Suppression Kit

8. The IR suppression kit (photo 9) has no moving parts and is designed to reduce the helicopter's IR signature by mixing ram

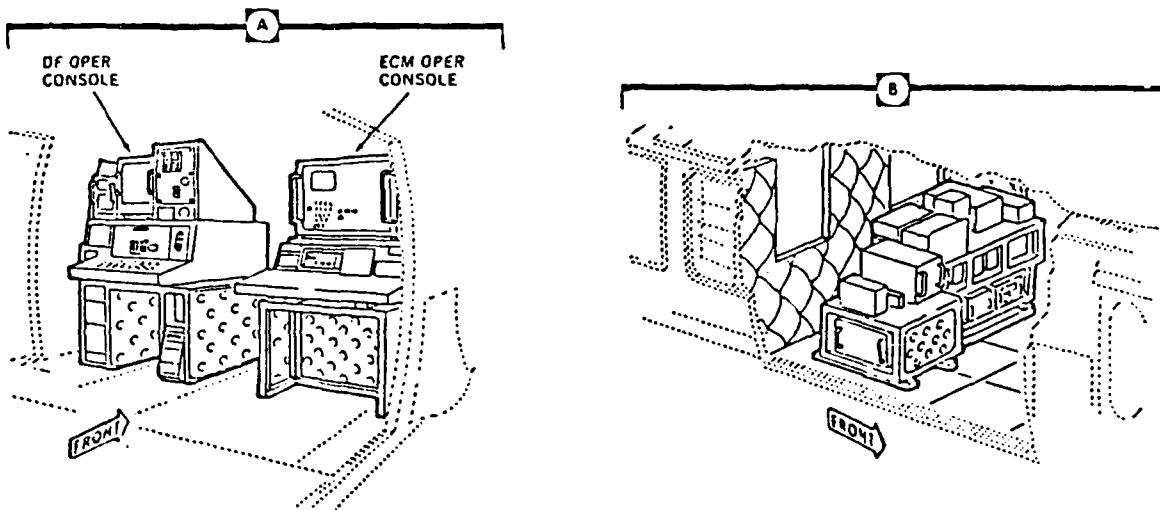
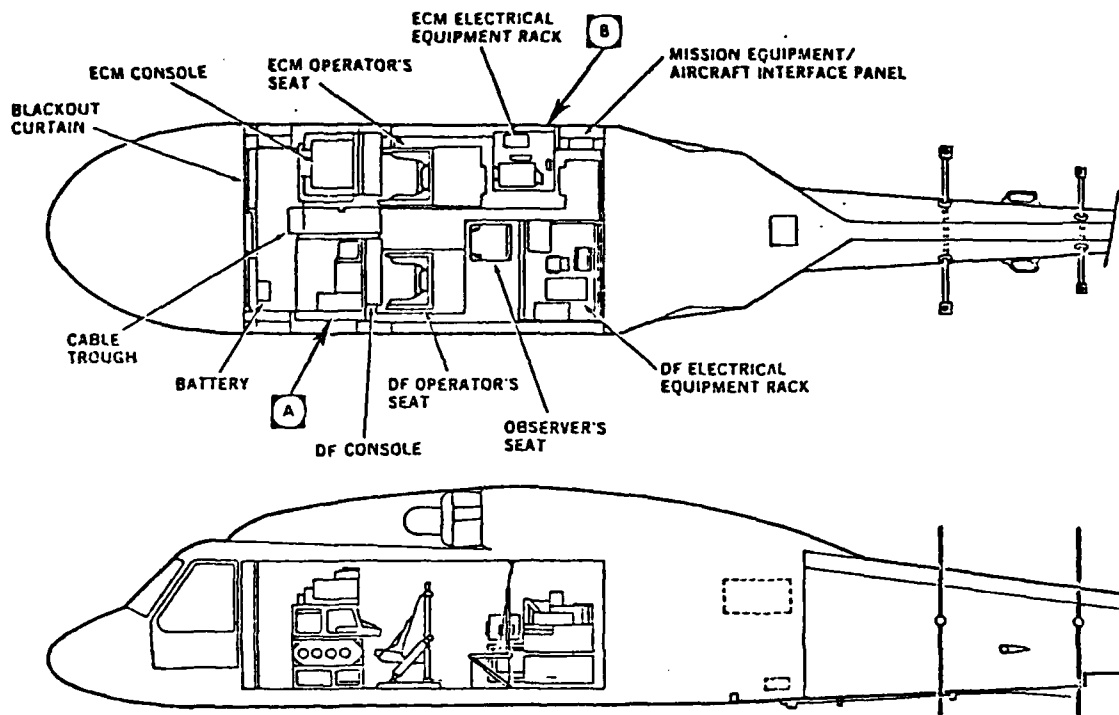

Figure 3. YEH-60A Cabin Equipment Arrangement



Photo 7. Integrated Inertial Navigation System (IINS)  
Central Display Unit (CDU)

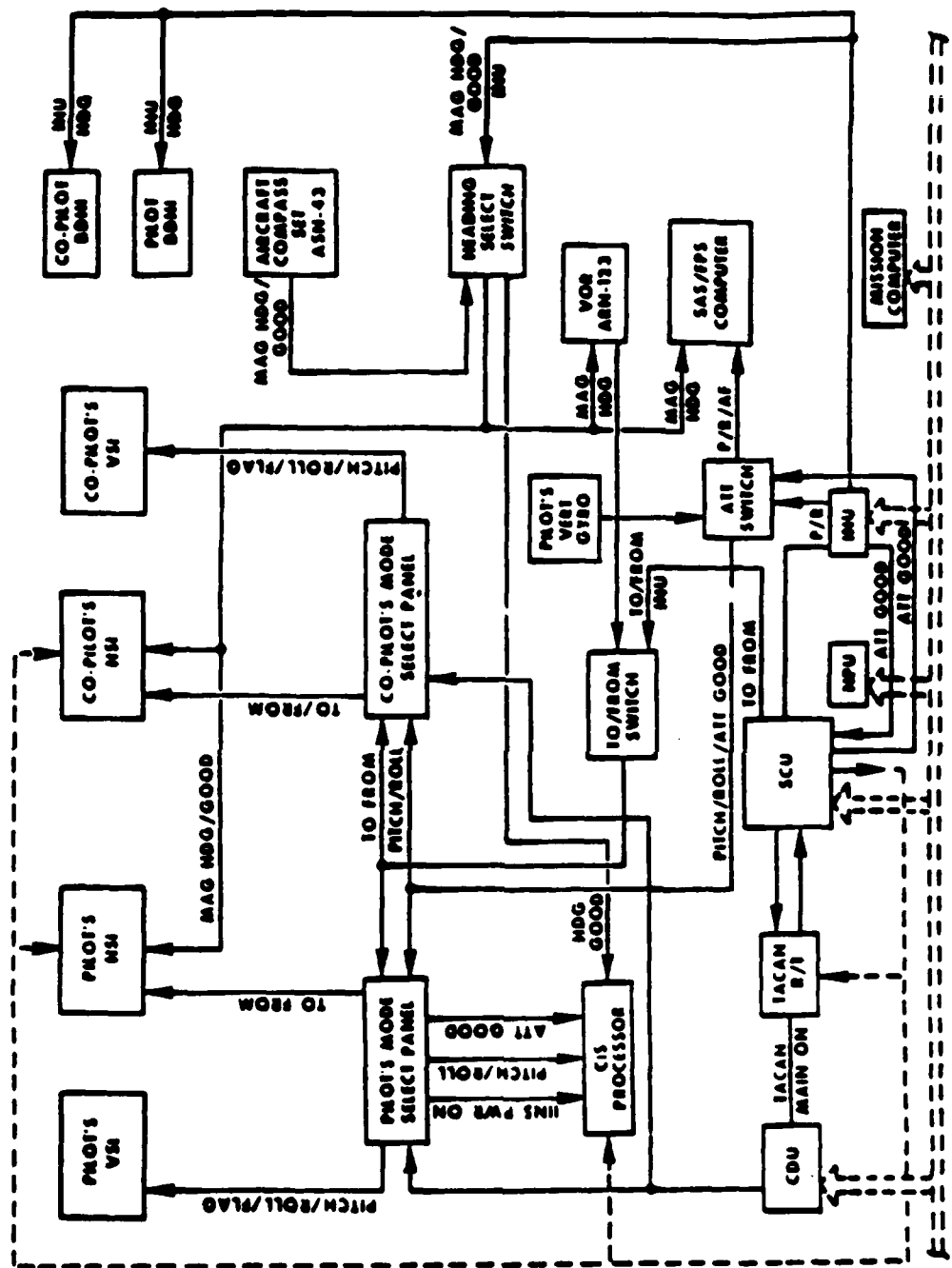

Figure 4. Interface of AN/ASN-132

NOTE: Dash lines indicate power BUS tie-in

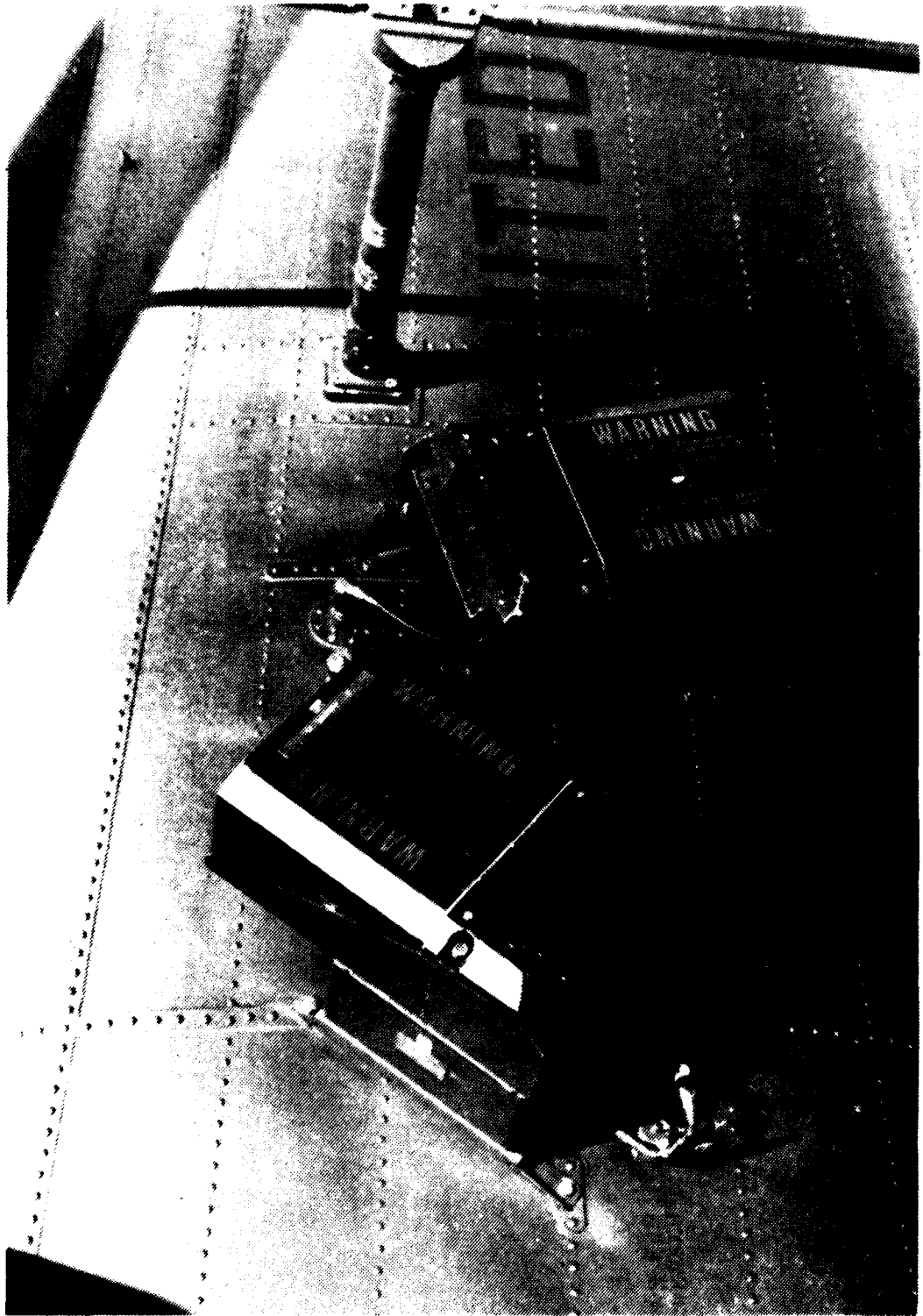

Photo 8. M-130 General Purpose Dispensers (2)



Photo 9. Infrared (IR) Suppression Kit

air with the engine exhaust gases and by blocking line-of-sight view of hot metal parts. The IR suppressor channels exhaust gases through a sheet metal core mounted within a fiberglass honeycomb-sandwich constructed nacelle. The suppressor core is constructed of short segments; each successive segment, in the direction of gas flow, has a larger cross-sectional area than the previous one. The inside surface of each segment is coated with low-reflectance material. Cooling air, entering the ram inlet scoop, is ducted around the suppressor core and passes through the gaps between overlapping core segments providing film-cooling of the core surface. The engine exhaust plume is cooled internally by mixing the core film-cooling air, and externally by crossflow mixing with ambient free-stream air at the suppressor exit. The core turns outboard to prevent line-of-sight seeking of the hot engine turbine and rear frame and to direct the engine exhaust into the free-stream air at a 75° angle promoting rapid exhaust mixing/cooling.

#### IR Countermeasure Set AN/ALQ-144(V)

9. The countermeasures system is designed to provide IR countermeasure capability. The system transmits radiation modulated mechanically at high and low frequencies using an electrically-heated source. A built-in test (BIT) feature monitors system operation and alerts the pilot should a malfunction occur. The system consists of a control panel on the instrument panel and a transmitter on top of the main rotor pylon aft of the main rotor (photo 10). When the control unit ON-OFF switch on the control panel is momentarily placed ON, the power distribution and control circuits are activated, the source begins to heat, the servo motor and drive circuits are energized turning on the high and low speed modulators, and a signal is applied to stabilize system operations before energizing the BIT function. After a warmup period, the stabilizing signal is removed and the system operates normally. Placing the ON-OFF control switch momentarily to OFF causes the power distribution and control circuits to de-energize the source and initiates a cool-down period. During the cool-down period, the servo motor drive circuits remain in operation, applying power to the motors that cause the modulators to continue turning.

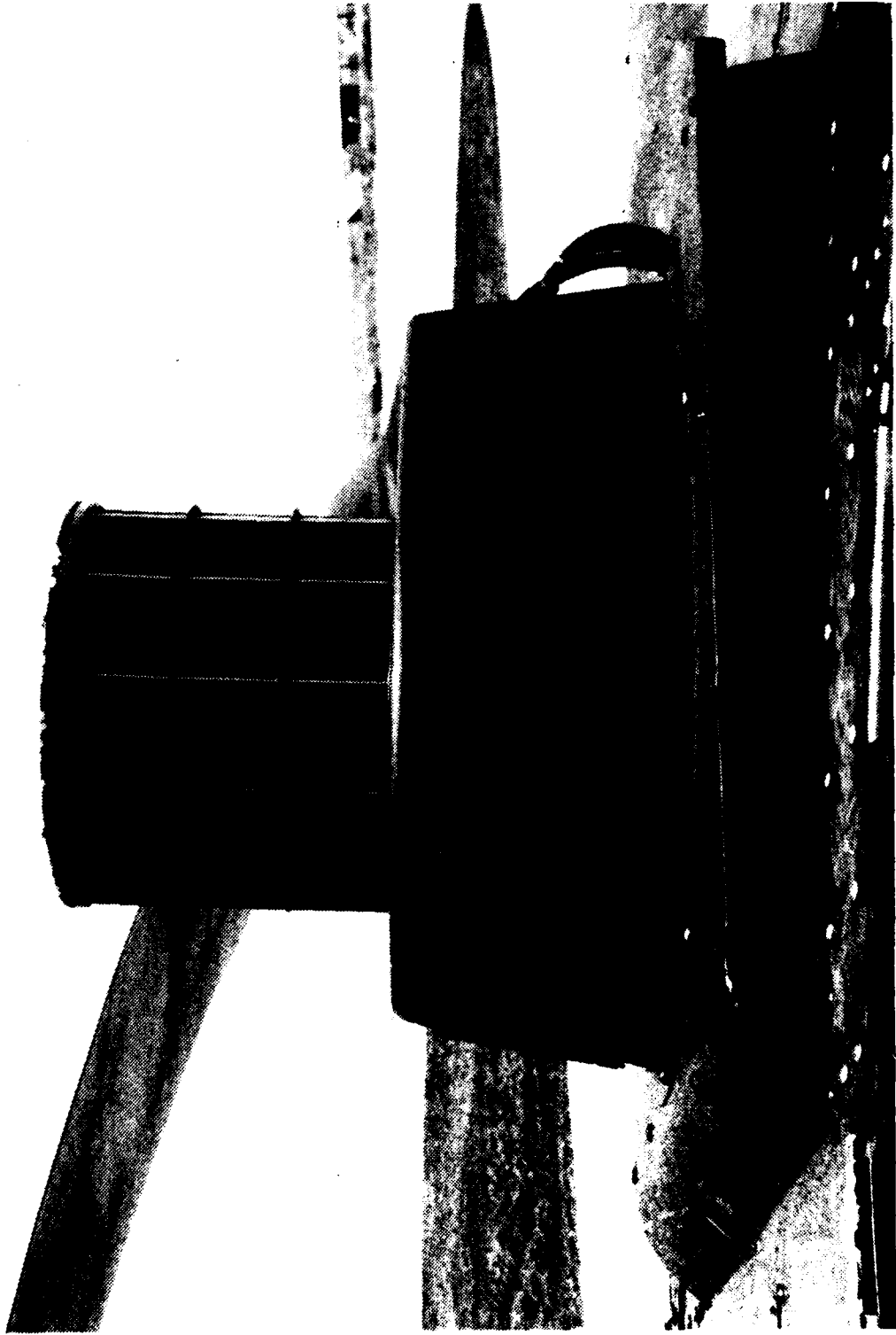

Photo 10. AN/ALQ-144(V) Infrared (IR) Countermeasure Mockup

## APPENDIX C. INSTRUMENTATION

### GENERAL

1. The test instrumentation was installed, calibrated and maintained by the US Army Aviation Engineering Flight Activity. A test boom, incorporating a swiveling pitot-static tube and side-slip vane, was installed at the nose of the aircraft. A total air temperature probe was mounted on the underside of the fuselage beneath the copilot's seat. A magnetic pickup attached to the swashplate telemetered a signal to the ground for determining main rotor speed. The following calibrated instrumentation was displayed as noted.

#### Pilot Station

Airspeed (boom)  
Altitude (boom)  
Sensitive bank angle (center of gravity lateral acceleration)

#### Copilot Station

Airspeed (ship)  
Altitude (ship)  
Turbine gas temperature (ship)\* \*\*  
Gas producer speed (ship)\* \*\*  
Stabilator position (ship)  
Control Positions  
    Longitudinal (tape measure)  
    Lateral (tape measure)  
    Directional (tape measure)

#### Engineer Station

Airspeed (boom)  
Altitude (boom)  
Engine output shaft torque\*\*  
Engine fuel used\*\*  
Auxiliary power unit fuel used  
Angle of sideslip  
Total air temperature

\*Uncalibrated  
\*\*Both engines

#### Airspeed Calibration

2. The aircraft's standard pitot-static system (ship) and the installed test pitot-static system (boom) were calibrated in level flight. Position error was determined using a measured

ground speed course. Position error data correlated with the results of reference 8, appendix A, and consequently these calibrations were utilized in this evaluation.

## APPENDIX D. TEST TECHNIQUES AND DATA ANALYSIS METHODS

### AIRCRAFT WEIGHT AND BALANCE

1. The aircraft was weighed in the test configuration without crew and with full oil and all fuel drained prior to the start of the program. The weight of the aircraft was 13,415 pounds with the longitudinal center of gravity (cg) located at fuselage station (FS) 356.2. The fuel cells and external sight gages were calibrated to determine quantity of fuel onboard. The measured fuel capacity using the gravity fueling method was 367 gallons. The fuel weight for each test flight was determined prior to engine start and after engine shutdown by using the external sight gage to determine the fuel volume and measuring it's specific gravity. Aircraft cg was controlled within  $\pm 1$  inch of aim by limiting each flight to a predetermined 600 pound fuel test range.

### AIRCRAFT RIGGING

2. A flight controls engineering rigging check was performed on the main and tail rotors to insure compliance with established limits and representative handling qualities information. The stabilator control system was adjusted to conform as close as possible to the original production schedule to prevent improper drag characteristics affecting level flight performance.

### PERFORMANCE

3. Helicopter performance was generalized through the use of nondimensional coefficients as follows using the 1968 US Standard Atmosphere:

- a. Coefficient of Power ( $C_p$ )

$$C_p = \frac{\text{SHP (550)}}{\rho A (\Omega R)^3} + C_{p \text{ corr}} \quad (1)$$

- b. Coefficient of Thrust ( $C_T$ ):

$$C_T = \frac{GW}{\rho A (\Omega R)^2} \quad (2)$$

c. Advance Ratio ( $\mu$ ):

$$\mu = \frac{V_T (1.6878)}{\Omega R} \quad (3)$$

Where:

SHP = Engine output shaft horsepower (total for both engines)

$$\rho = \text{Ambient air density (lb-sec}^2/\text{ft}^4) = \rho_o \left( \frac{\delta}{\theta} \right)$$

$$\rho_o = 0.0023769 \text{ (lb-sec}^2/\text{ft}^4)$$

$$\delta = \text{Pressure ratio} = \frac{P_a}{P_{ao}}$$

$P_a$  = Ambient air pressure (in.-Hg)

$P_{ao}$  = 29.92126 in.-Hg

$$\theta = \text{Temperature ratio} = \frac{OAT + 273.15}{288.15}$$

OAT = Ambient air temperature ( $^{\circ}$ C)

A = Main rotor disc area = 2262 ft<sup>2</sup>

$\Omega$  = Main rotor angular velocity (radians/sec)

R = Main rotor radius = 26.833 ft

$C_{p_{corr}}$  = Correction to  $C_p$  due to  $N_R/\sqrt{\theta}$  not equal to 258 rpm

$N_R$  = Main rotor speed (rev/min)

GW = Gross weight (lb)

$$V_T = \text{True airspeed (kt)} = \frac{V_E}{1.6878\sqrt{\rho/\rho_o}}$$

1.6878 = Conversion factor (ft/sec-kt)

$V_E$  = Equivalent airspeed (ft/sec) =

$$\left\{ \frac{7(70.7262 P_a)}{\rho_0} \left( \left[ \left( \frac{Q_c}{P_a} \right) + 1 \right]^{2/7} - 1 \right) \right\}^{1/2}$$

70.7262 = Conversion factor (lb/ft<sup>2</sup>-in.-Hg)

$Q_c$  = Dynamic pressure (in.-Hg)

At the normal operating rotor speed of 257.9 (100%), the following constants may be used to calculate  $C_p$  and  $C_T$ :

$$\Omega_R = 724.685$$

$$(\Omega_R)^2 = 525,168.15$$

$$(\Omega_R)^3 = 380,581,411.2$$

4. Each speed power was flown in ball-centered flight by reference to a calibrated lateral accelerometer at a predetermined  $C_T$  and referred rotor speed ( $N_R/\sqrt{\delta}$ ). To maintain  $N_R/\sqrt{\delta}$  constant, rotor speed was decreased as temperature decreased. To maintain the ratio of gross weight to pressure ratio ( $W/\delta$ ) constant, altitude was increased as fuel was consumed. A constant fuel temperature of 55°C was used in the determination of engine fuel consumed based upon the test results of reference 12, appendix A.

5. The engine output shaft torque was determined by use of the engine torque sensor. The power turbine shaft contains a torque sensor tube that measure the total twist of the shaft. A concentric reference shaft is secured by a pin at the front end of the power turbine drive shaft and is free to rotate relative to the power turbine drive shaft at the rear end. The relative rotation is due to transmitted torque, and the resulting phase angle between the reference teeth on the two shafts is picked up by the torque sensor. This torque sensor for both engines was calibrated in a test cell by the engine manufacturer. The output from the engine torque sensor was displayed at the electronic countermeasures operator's station. The output SHP was determined from the engine's output shaft torque and rotational speed by the following equation.

$$\text{SHP} = \frac{Q(N_p)}{5252.113} \quad (4)$$

Where:

$Q$  = Engine output shaft torque (ft-lb)

$N_p$  = Engine output shaft rotational speed (rpm)

5252.113 = Conversion factor (ft-lb-rev/min-SHP)

The output SHP required was assumed to include 13 horsepower for daylight operations of the aircraft electrical system, but was corrected for the effects of test instrumentation installation. A power loss of 0.25 horsepower was determined for electrical operation of the instrumentation. Reductions in power required were made for the effect of external instrumentation drag. This was determined by the following equation.

$$\Delta\text{SHP}_{\text{instr drag}} = \frac{\Delta F_e (\rho/\rho_o)(V_T^3)}{96254} \quad (5)$$

Where:

$\Delta F_e = 0.69 \text{ ft}^2$  (estimated)

96254 = Conversion factor (ft<sup>2</sup>-kt<sup>3</sup>/SHP)

Power required for level flight at the test day conditions was determined using the following equation.

$$\text{SHP}_t = \text{SHP} - \Delta\text{SHP}_{\text{instr drag}} - 0.25 \quad (6)$$

Test data were corrected to an  $N_R/\sqrt{\theta}$  reference of 258 rpm, as shown in equation 1 ( $C_{p_{\text{corr}}}$ ), based on the family of carpet plots

( $C_p$  versus  $N_R/\sqrt{\theta}$  for constant  $C_T$  at increments of  $\mu$ ) presented in figures 15 through 30 in reference 8, appendix A.

6. Test-day (measured) level flight data was corrected to average test day conditions by the following equation.

$$\text{SHP}_s = \text{SHP}_t \frac{(\delta_s \sqrt{\theta_s}) \left[ \frac{N_R}{\sqrt{\theta}} \right]_s^3}{(\delta_t \sqrt{\theta_t}) \left[ \frac{N_R}{\sqrt{\theta}} \right]_t^3} \quad (7)$$

Where:

Subscript t = Test day

Subscript s = Average test day

$$(N_R/\sqrt{\theta})_t = (N_R/\sqrt{\theta})_s$$

Test data, corrected for instrumentation installation, to a  $N_R/\sqrt{\theta}$  of 258 rpm, and to average test day altitude and ambient temperature, are presented in figures 9 through 12, appendix E. A family of curves of  $C_p$  versus  $C_T$  for a constant  $\mu$ , representing the YEH-60A in mission configuration at the aim  $N_R/\sqrt{\theta}$  of 258 rpm in ball-centered flight, is presented in figures 6 through 8.

7. Conversion of ball-center test data to a zero sideslip trim condition was made to compare with the analysis in reference 8, appendix A. This data were used to determine the increase in equivalent flat plate area due to the installation of the AN/ALQ-151(V)2 countermeasures system and associated mission equipment. The curve of change in equivalent flat plate area ( $\Delta F_e$ ) as a function of sideslip angle in reference 8, figure 46, and the following equation, were used to determine differences in power coefficient between the sideslip angle measured in ball-centered flight and zero sideslip.

$$\Delta C_p = \frac{\Delta F_e \mu^3}{2A} \quad (8)$$

Where:

$\Delta C_p$  = Change in coefficient of power

$\Delta F_e$  = Change in equivalent flat plate area ( $\text{ft}^2$ ), ref 8  
(Based on change in engine shaft horsepower)

The power coefficient for comparison purposes ( $C_{p_{cmprsn}}$ ) depicting test data at  $N_R/\sqrt{\theta}$  of 258 rpm and zero sideslip was obtained by the following equation.

$$C_{p_{cmprsn}} = C_p - \Delta C_p \quad (9)$$

8. The family of curves from reference 8, appendix A, for a  $N_R/\sqrt{\theta}$  of 258 rpm was adjusted to the test center of gravity using equation 8 and a correction of  $\Delta F_e$  of 2 ft<sup>2</sup> determined from the same reference to account for the difference in cg.

9. The  $\Delta F_e$  of the Quick Fix configuration changes to the normal utility configured UH-60A was derived by converting the differences in  $C_p$  between  $C_{p_{cmprsn}}$  and the  $C_p$  of the family of

curves from reference 8 adjusted for cg to  $\Delta F_e$  using equation 8 for each  $C_T$ . These differences were further refined by fairing the  $\Delta F_e$  between the Quick Fix and normal utility configurations versus  $\mu$  to produce the nominal value(s) presented in figure 1, appendix E.

10. The specific range (SR) data were derived from the test level flight power required and fuel flow ( $W_{F_t}$ ). Level flight performance SHP and fuel flow data for each engine were referred as follows.

$$SHP_{REF} = \frac{SHP_t}{\delta\theta 0.5} \quad (10)$$

$$W_{F_{REF}} = \frac{W_{F_t}}{\delta\theta 0.55} \quad (11)$$

A curve fit was subsequently applied to this referred data and was used as the basis to correct  $W_{F_t}$  to standard day fuel flow using the following equation.

$$W_{F_s} = W_{F_t} + \Delta W_F \quad (12)$$

Where:

$\Delta W_F$  = Change in fuel flow between SHP<sub>t</sub> and SHP<sub>s</sub>

The following equation was used for determination of specific range.

$$SR = \frac{V_T}{W_{F_s}} \quad (13)$$

### HANDLING QUALITIES

#### General

11. Conventional test techniques were used during the conduct of the handling qualities tests. All tests were conducted in ball-centered flight. Longitudinal and lateral cyclic, directional pedal, and collective control positions were obtained utilizing hand held tape measures during selected test conditions. Detailed descriptions of all test techniques are contained in reference 9, appendix A.

#### DEFINITIONS

12. Results were categorized as deficiencies or shortcomings in accordance with the following definitions.

Deficiency: A defect or malfunction discovered during the life cycle of an item of equipment that constitutes a safety hazard to personnel; will result in serious damage to the equipment if operation is continued; or indicates improper design or other cause of failure of an item or part, which seriously impairs the equipment's operational capability.

Shortcoming: An imperfection or malfunction occurring during the life cycle of equipment, which must be reported and which should be corrected to increase efficiency and to render the equipment completely serviceable. It will not cause an immediate breakdown, jeopardize safe operation, or materially reduce the usability of the materiel or end product.

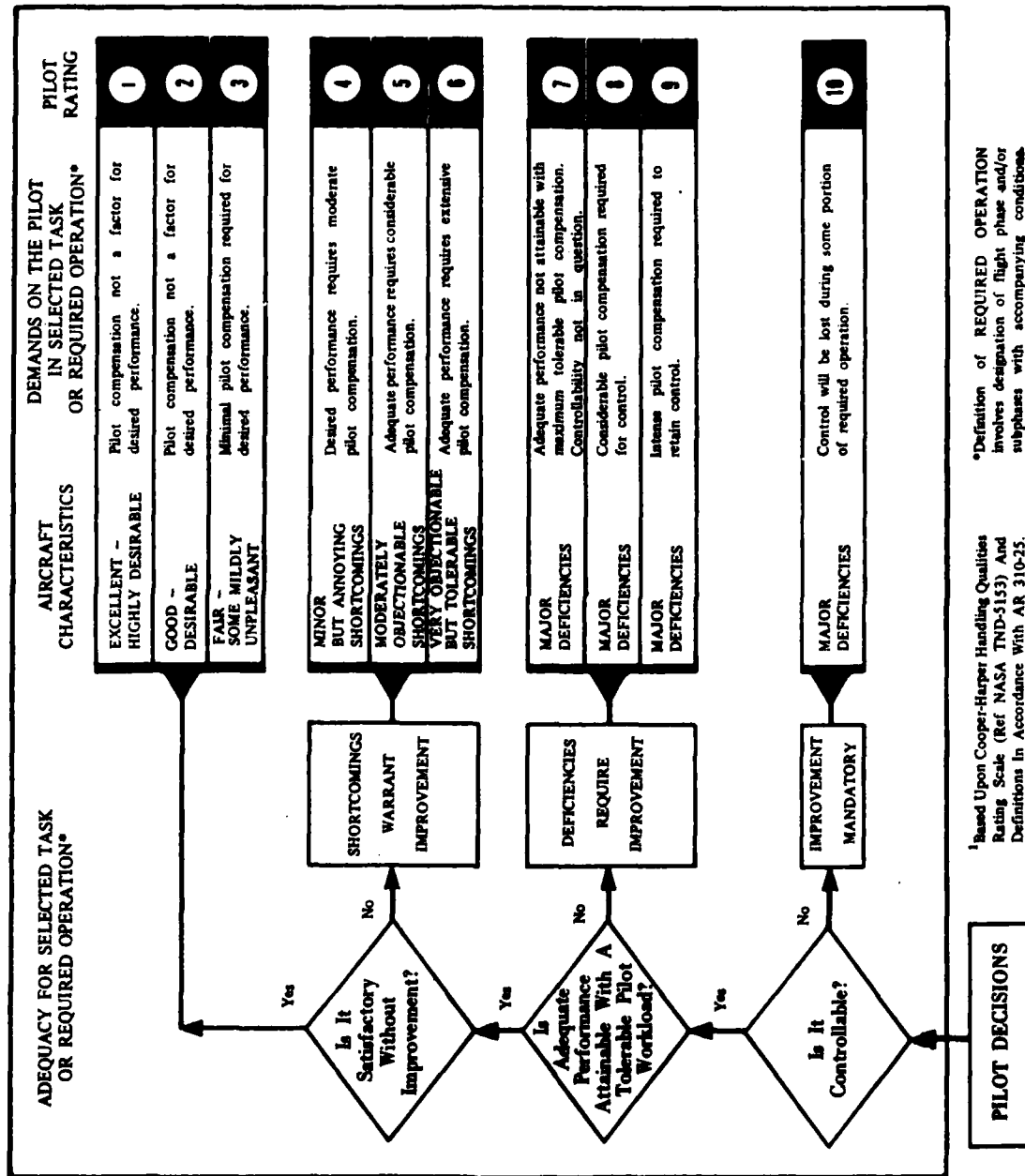

\*Definition of REQUIRED OPERATION involves designation of flight phase and/or subphases with accompanying conditions.

<sup>1</sup>Based Upon Cooper-Harper Handling Qualities Rating Scale (Ref NASA TND-5153) And Definitions In Accordance With AR 310-25.

Figure 1. Handling Qualities Rating Scale

# APPENDIX E. TEST DATA

## INDEX

<u>Figure</u>	<u>Figure Number</u>
Equivalent Flat Plate Area Comparison	1
Nondimensional Drag Characteristics	2 through 5
Nondimensional Level Flight Performance	6 through 8
Level Flight Performance	9 through 12

**FIGURE 1**  
**EQUIVALENT FLAT PLATE AREA COMPARISON**

YEH-00A USA S/N 79-23301  
 QUICK FDX CONFIGURATION

- NOTES:
1. REFERRED ROTOR SPEED = 258
  2. ZERO SIDESLIP TRIM CONDITION
  3. AVERAGE LONGITUDINAL CENTER OF GRAVITY OF FS 359.2
  4. LATERAL CENTER OF GRAVITY OF BL 0.3 LEFT
  5. CURVES DERIVED FROM POINTS IN FIGURES 2 THRU 5 AND BASELINE FROM USAAEFA REPORT NO. 77-17

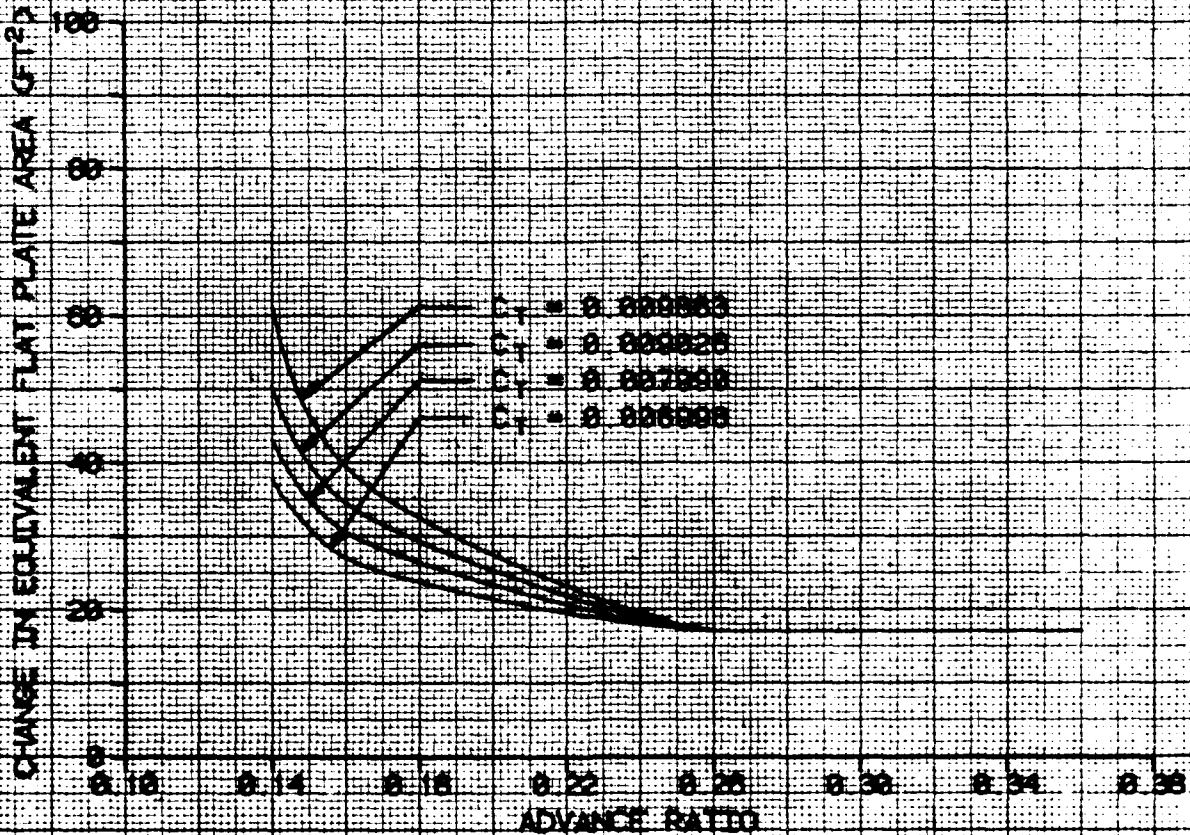

FIGURE 2  
NONDIMENSIONAL DRAG CHARACTERISTICS

YEH-60A USA S/N 79-23301  
QUICK FIX CONFIGURATION

- NOTES:
1. THRUST COEFFICIENT = 0.006998
  2. REFERRED ROTOR SPEED = 258
  3. ZERO SIDESLIP TRIM CONDITION
  4. AVERAGE LONGITUDINAL CENTER OF GRAVITY OF FS 359.2
  5. LATERAL CENTER OF GRAVITY OF BL 0.3 LEFT
  6. CURVE OBTAINED FROM USAAEFA REPORT NO. 77-17 WITH  $\Delta F_e$  FROM FIGURE 1 INCORPORATED

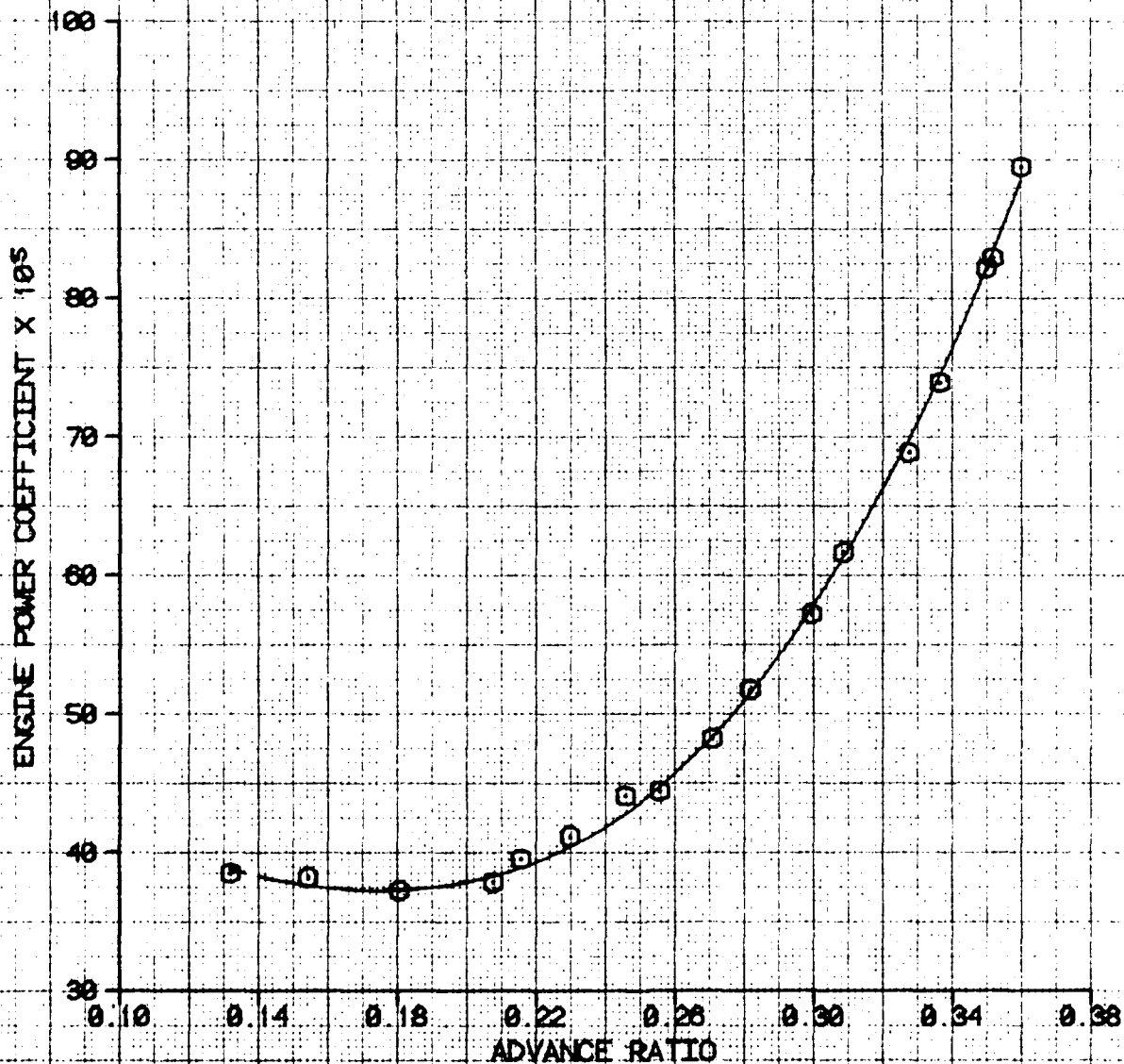

FIGURE 3  
NONDIMENSIONAL DRAG CHARACTERISTICS

YEH-60A USA S/N 79-23301  
QUICK FIX CONFIGURATION

NOTES:

1. THRUST COEFFICIENT = 0.007990
2. REFERRED ROTOR SPEED = 258
3. ZERO SIDESLIP TRIM CONDITION
4. AVERAGE LONGITUDINAL CENTER OF GRAVITY OF FS 359.2
5. LATERAL CENTER OF GRAVITY OF BL 0.3 LEFT
6. CURVE OBTAINED FROM USAAEFA REPORT NO. 77-17 WITH  $\Delta F_e$  FROM FIGURE 1 INCORPORATED

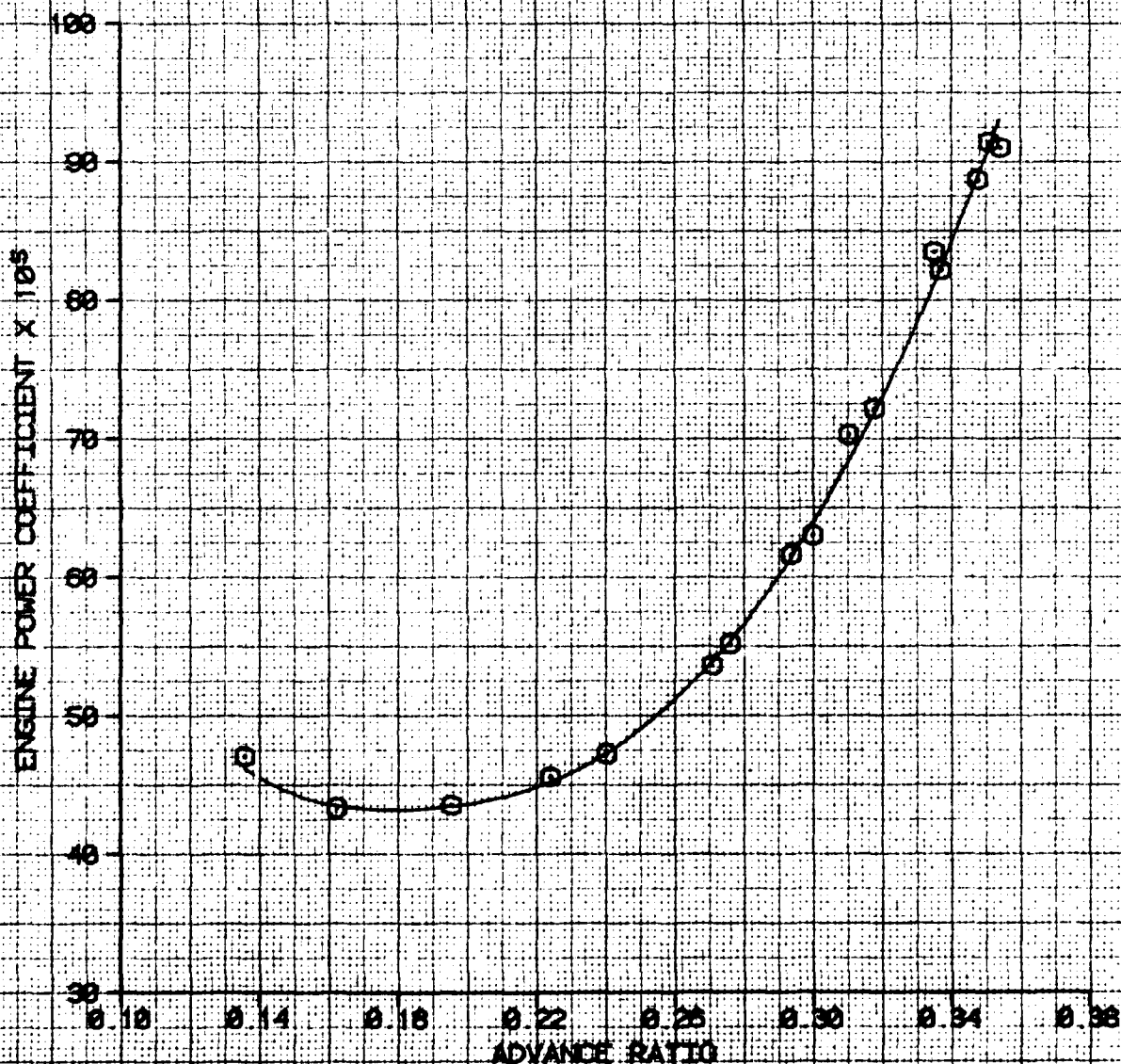
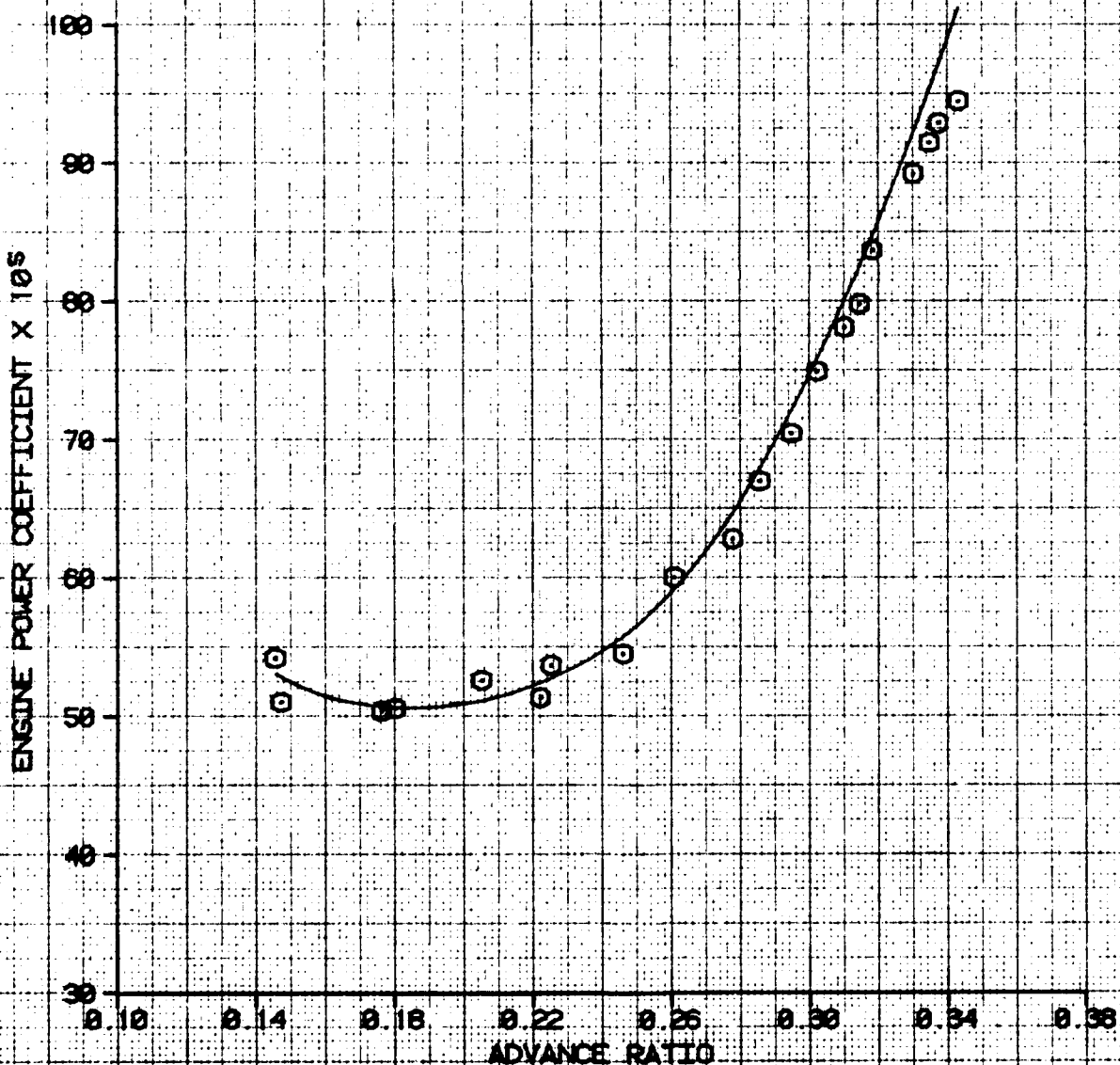

FIGURE 4  
NONDIMENSIONAL DRAG CHARACTERISTICS

YEH-68A USA S/N 79-23301  
QUICK FIX CONFIGURATION

NOTES:

1. THRUST COEFFICIENT = 0.009026
2. REFERRED ROTOR SPEED = 258
3. ZERO SIDESLIP TRIM CONDITION
4. AVERAGE LONGITUDINAL CENTER OF GRAVITY OF FS 359.2
5. LATERAL CENTER OF GRAVITY OF BL 0.3 LEFT
6. CURVE OBTAINED FROM USAAEFA REPORT NO. 77-17 WITH  $\Delta F_z$  FROM FIGURE 1 INCORPORATED



**FIGURE 5**  
**NONDIMENSIONAL DRAG CHARACTERISTICS**  
 YEH-60A USA S/N 79-23301  
 QUICK FIX CONFIGURATION

- NOTES:
1. THRUST COEFFICIENT = 0.020663
  2. REFERRED ROTOR SPEED = 258
  3. ZERO SIDESLIP TRIM CONDITION
  4. AVERAGE LONGITUDINAL CENTER OF GRAVITY OF FS 359.2
  5. LATERAL CENTER OF GRAVITY OF BL 0.3 LEFT
  6. CURVE OBTAINED FROM USAAEFA REPORT NO. 77-17 WITH  $\Delta F_z$  FROM FIGURE 1 INCORPORATED

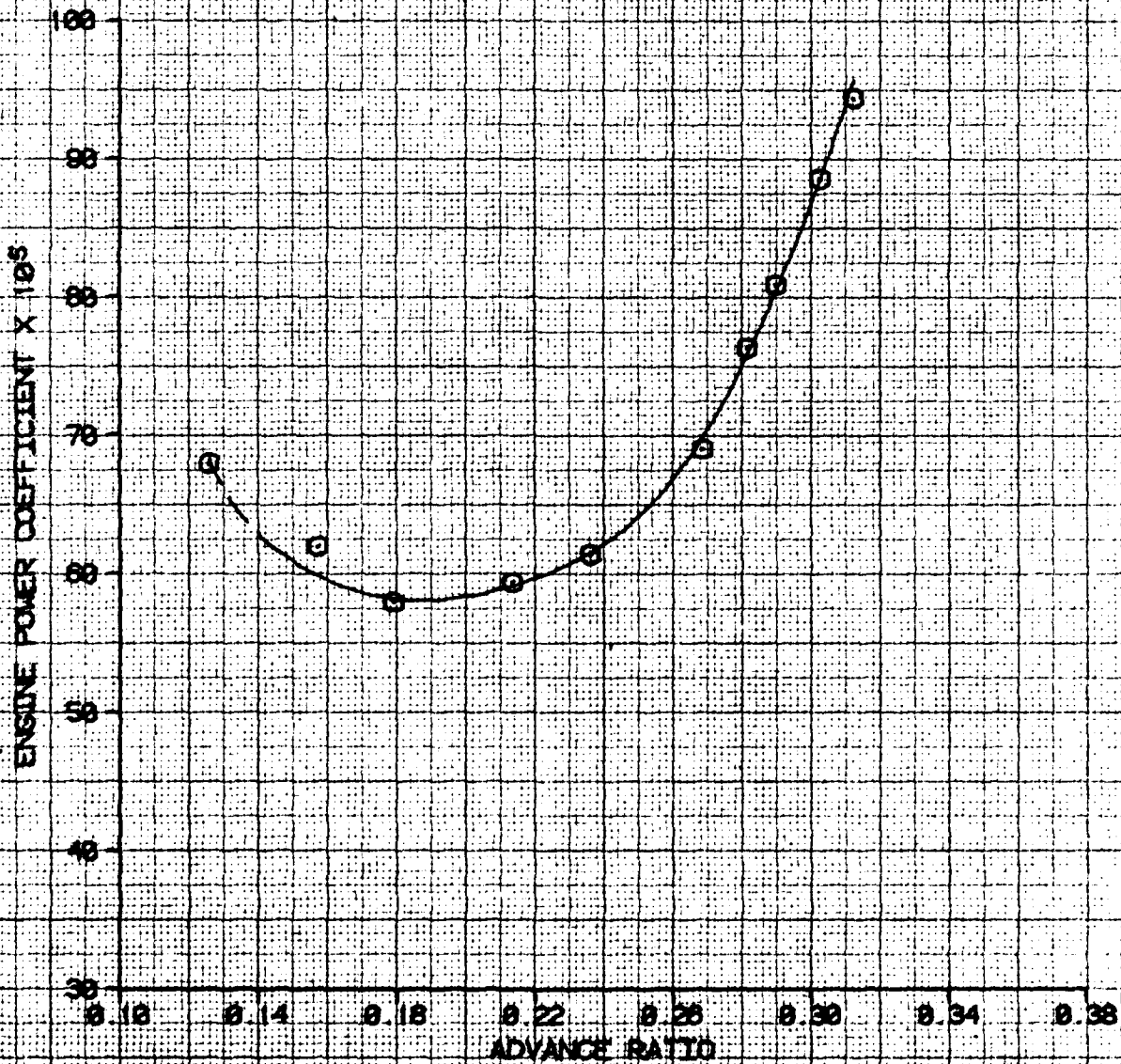

FIGURE 6  
 NONDIMENSIONAL LEVEL FLIGHT PERFORMANCE  
 YEH-80A USA S/N 79-23301  
 QUICK FIX CONFIGURATION

NOTES:

1. REFERRED ROTOR SPEED = 258
2. BALL CENTER TRIM CONDITION
3. AVERAGE LONGITUDINAL CENTER OF GRAVITY OF FS 359.2
4. LATERAL CENTER OF GRAVITY OF BL 0.3 LEFT
5. POINTS DERIVED FROM FIGURES 9 THRU 12

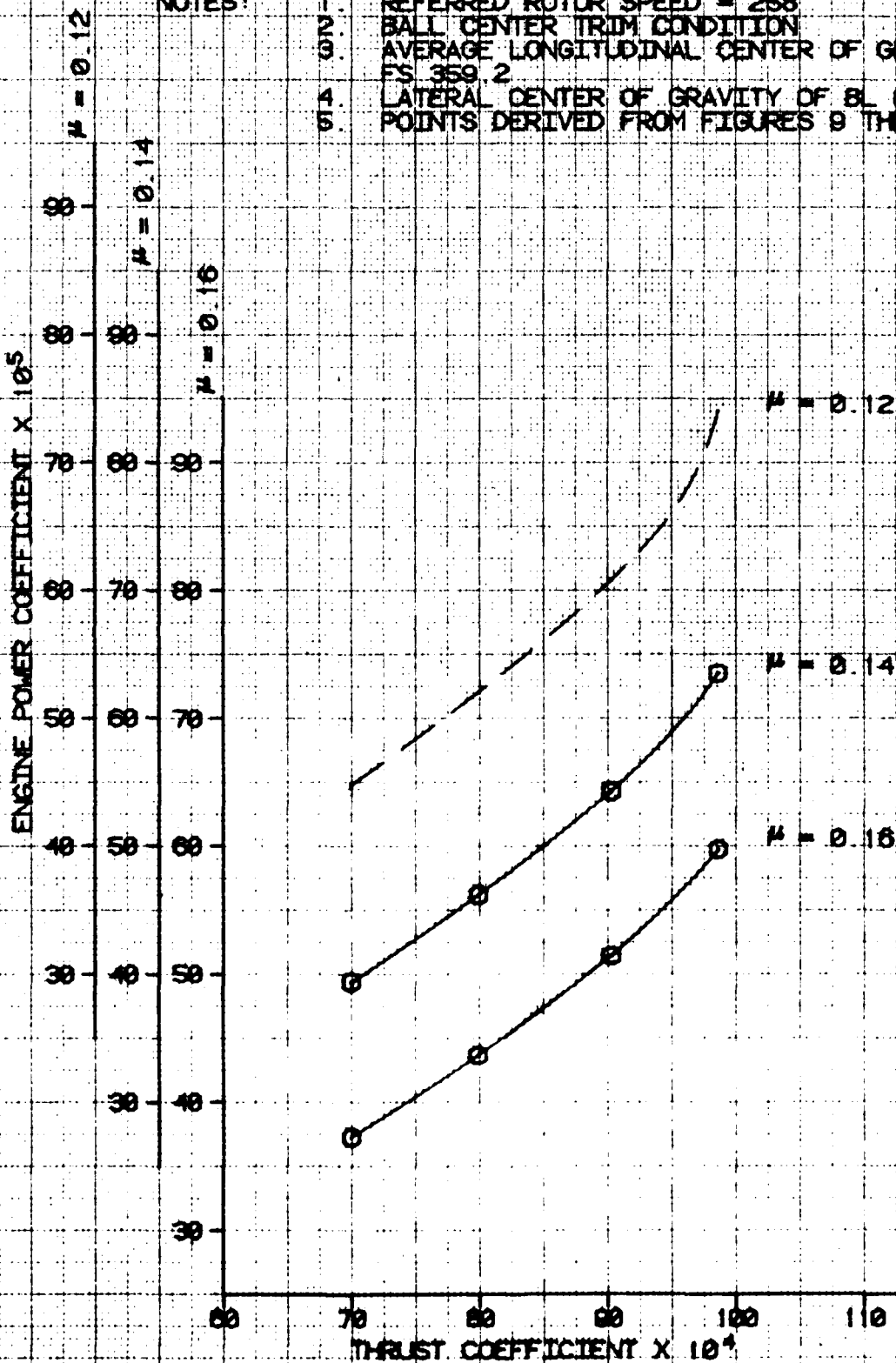
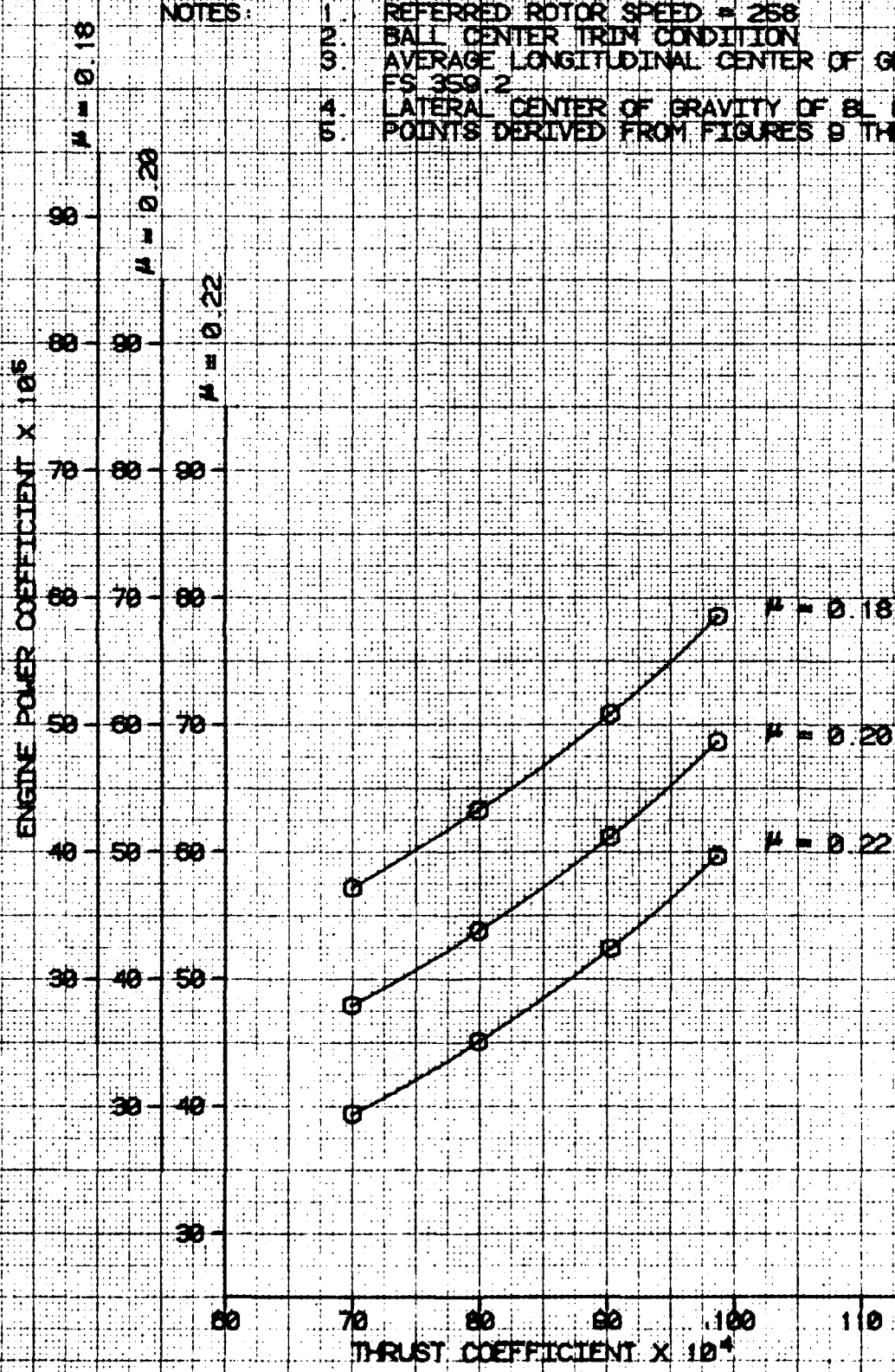

FIGURE 7  
 NONDIMENSIONAL LEVEL FLIGHT PERFORMANCE

YEH-60A USA S/N 79-23301  
 QUICK FIX CONFIGURATION

NOTES:

1. REFERRED ROTOR SPEED = 258
2. BALL CENTER TRIM CONDITION
3. AVERAGE LONGITUDINAL CENTER OF GRAVITY OF FS 359.2
4. LATERAL CENTER OF GRAVITY OF BL 0.3 LEFT
5. POINTS DERIVED FROM FIGURES 9 THRU 12



**FIGURE 8**  
**NONDIMENSIONAL LEVEL FLIGHT PERFORMANCE**  
**YB-60A USA S/N 78-23381**  
**QUICK FIX CONFIGURATION**

- NOTES:**
1. REFERRED ROTOR SPEED = 268
  2. HULL CENTER TRIM CONDITION
  3. AVERAGE LONGITUDINAL CENTER OF GRAVITY OF AS 350.2
  4. LATERAL CENTER OF GRAVITY OF B.L. 0.3 LEFT
  5. POINTS DERIVED FROM FIGURES 9 THRU 12

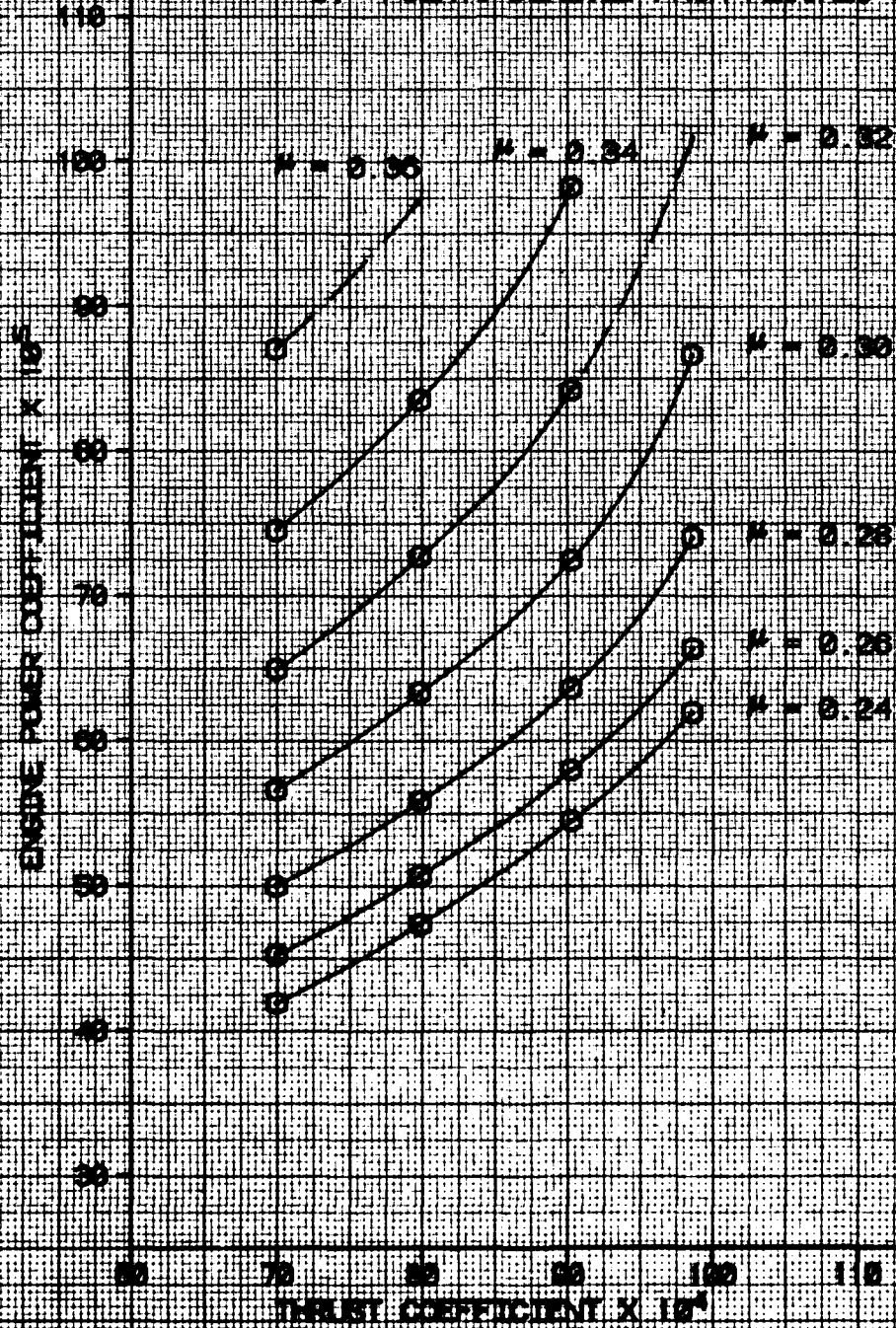
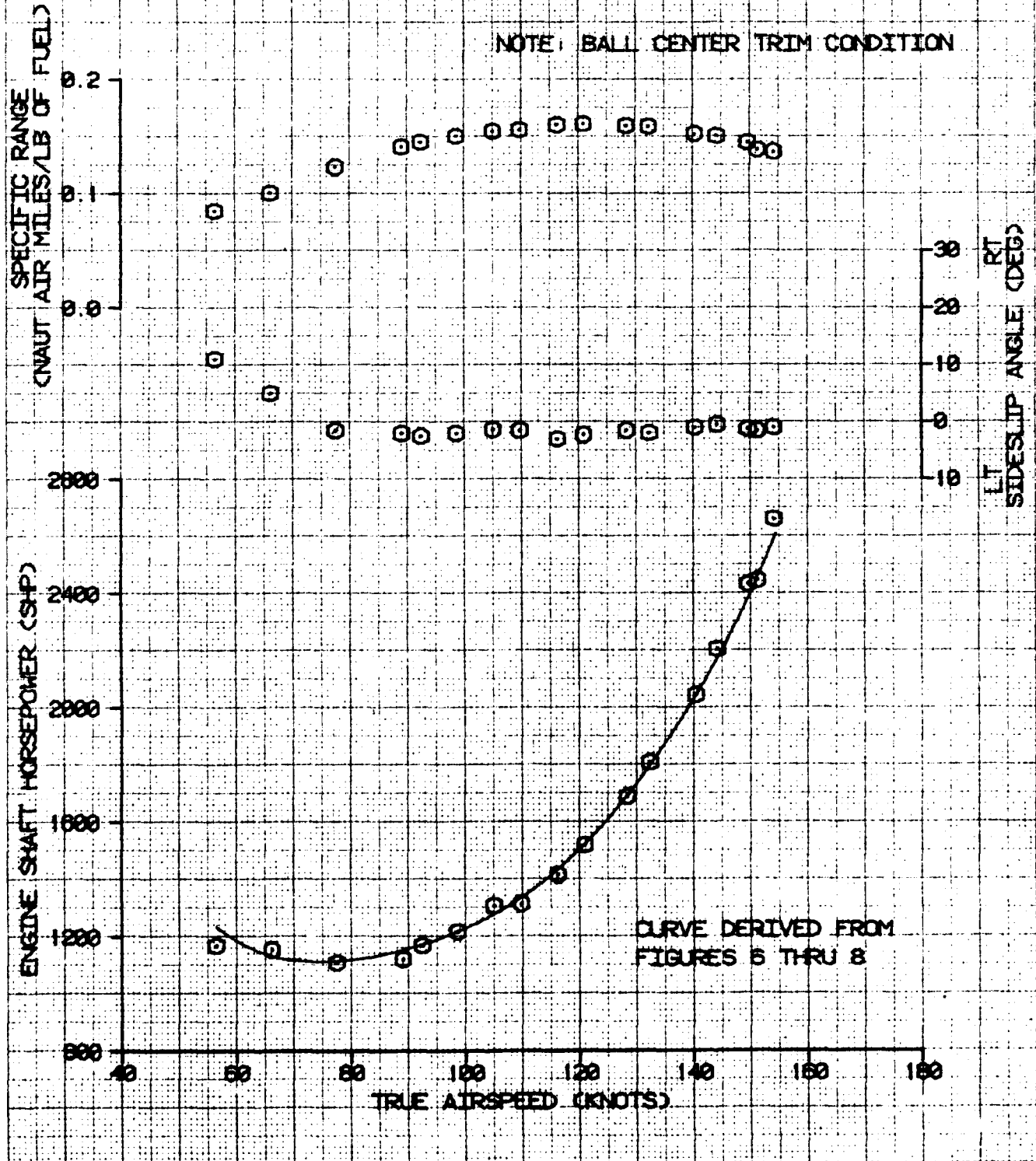

FIGURE 9  
 LEVEL FLIGHT PERFORMANCE  
 YEH-60A USA S/N 79-23301  
 QUICK FIX CONFIGURATION

AVG GROSS WEIGHT (LB)	AVG CG LOCATION		AVG DENSITY ALTITUDE (FT)	AVG OAT (DEG C)	REFERRED ROTOR SPEED (RPM)	AVG THRUST COEFFICIENT
	LONG (FS)	LAT (BL)				
15920	359.1	0.3LT	7170	14.5	258.0	0.006998

NOTE: BALL CENTER TRIM CONDITION



CURVE DERIVED FROM FIGURES 6 THRU 8

FIGURE 10  
 LEVEL FLIGHT PERFORMANCE  
 YB-90A USA S/N 70-2000  
 QUICK FIX CONFIGURATION

AVG DENSITY (LBS/FT <sup>3</sup> )	AVG GE CORRECTION (LBS)	AVG GE CORRECTION (LBS)	AVG DENSITY (LBS/FT <sup>3</sup> )	AVG DENSITY (LBS/FT <sup>3</sup> )	REFFERED TORQUE (HP)	AVG THRUST COEFFICIENT
0.000	0.000	0.000	0.000	0.000	250.0	0.00000

NOTE: BALL CENTER TRIM CONDITION

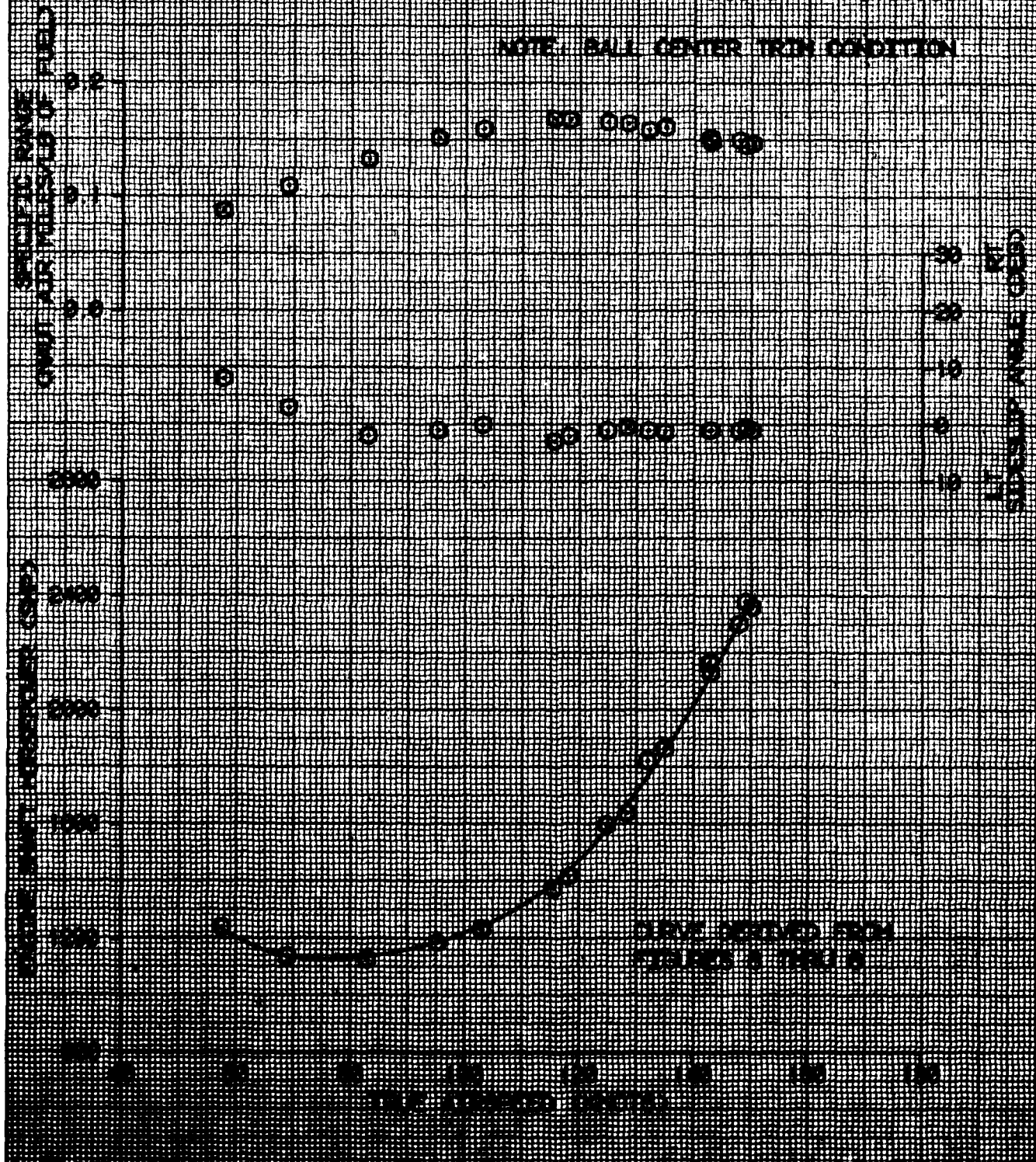

DISCONTINUED FROM  
 FIGURE 9, PAGE 9

**FIGURE 11  
LEVEL FLIGHT PERFORMANCE  
YEH-60A USA S/N 79-23301  
QUICK FIX CONFIGURATION**

AVG GROSS WEIGHT (LB)	AVG CG LOCATION		AVG DENSITY ALTITUDE (FT)	AVG DAT (DEG C)	REFERRED ROTOR SPEED (RPM)	AVG THRUST COEFFICIENT
	LONG (FSS)	LAT (CL)				
15930	359.1	0.3LT	13590	0.0	258.0	0.009026

NOTE: BALL CENTER TRIM CONDITION

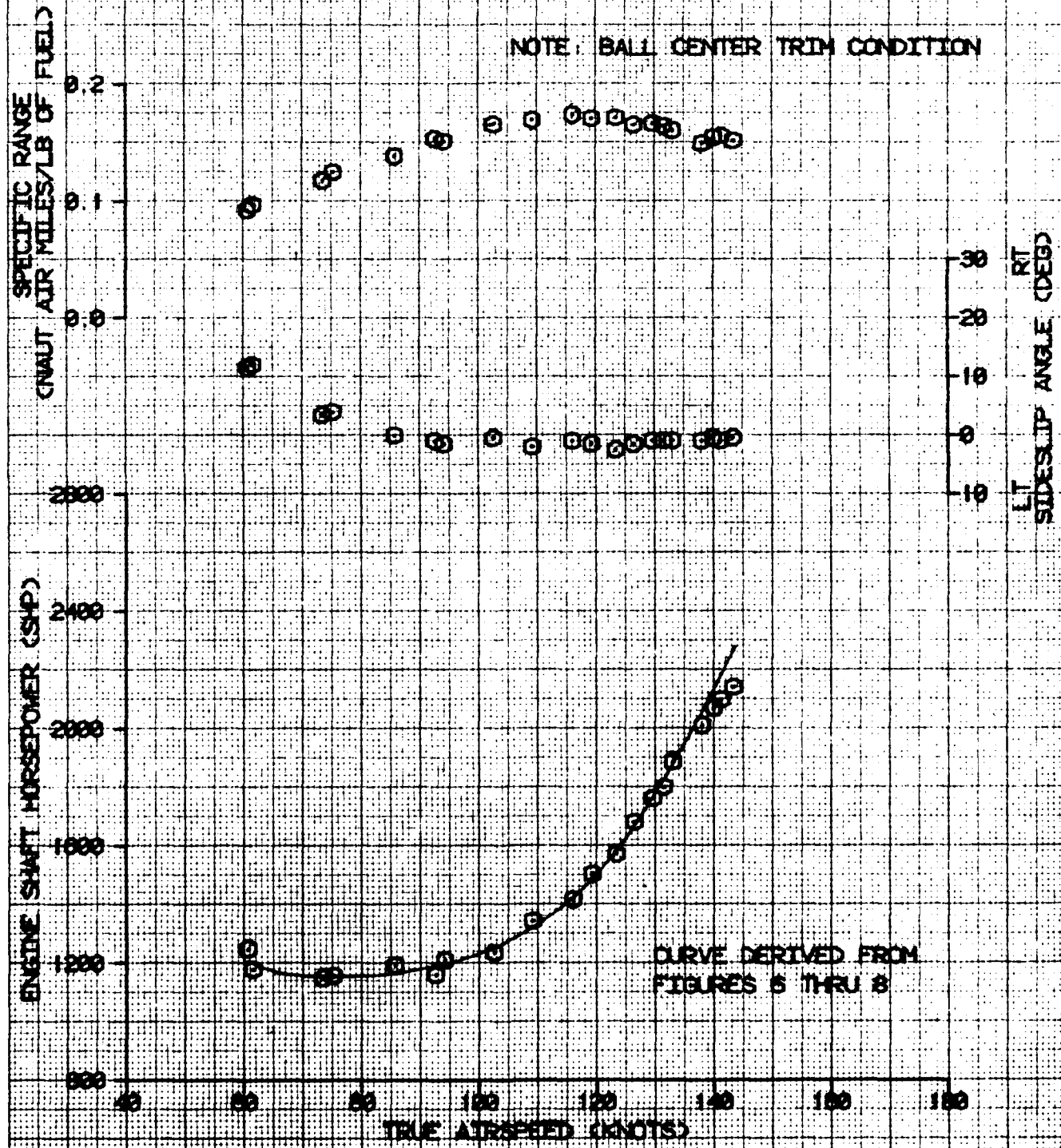

**FIGURE 12**  
**LEVEL FLIGHT PERFORMANCE**  
 YEH-60A USA S/N 79-2330  
 QUICK FIX CONFIGURATION

Avg TAS (KTS)	Avg CG Location (KFS)	Avg Density Altitude (FT)	Avg DAT (DEG C)	Referenced Rotor Speed (RPM)	Avg Thrust Coefficient
10000	358.7	0.327	15000	255.0	0.00000

NOTE: BALL CENTER TRIM CONDITION

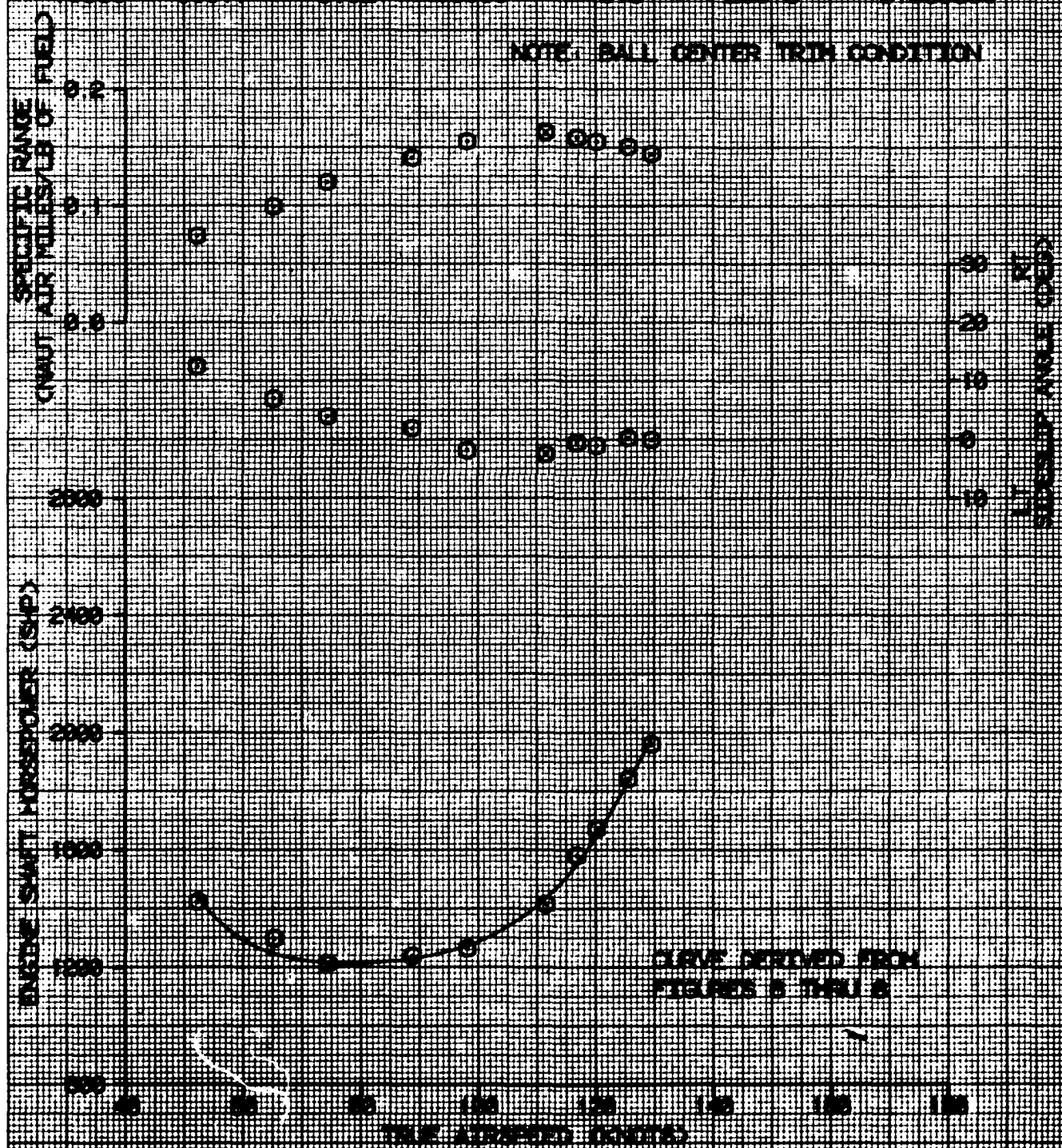

DATA DERIVED FROM FIGURES 8 AND 9

## APPENDIX F. EQUIPMENT PERFORMANCE REPORTS

The following Equipment Performance Reports (EPR) were submitted during the YEH-60A Quick Fix configured helicopter Airworthiness and Flight Characteristics program.

<u>EPR No.</u>	<u>Date Submitted</u>	<u>Description Title</u>
83-20-1	16 May 1984	Failure of the AN/ASN-132(V) Integrated Inertial Navigation System
83-20-2	17 May 1984	Chaffed power assembly harness of the AN/ALQ-144 Infrared Countermeasures System

# DISTRIBUTION

HQDA (DALO-SMM, DALO-AV, DALO-RQ, DAMO-HRS, DAMA-PPM-T, DAMA-RA, DAMA-WSA, DACA-EA)	8
US Army Materiel Command (AMCDE-SA, AMCQA-E, AMCDE-I, AMCDE-P, AMCQA-SA, AMCSM-WA AMCQA-ST)	7
US Army Training and Doctrine Command (ATTG-U, ATCD-T, ATCD-ET, ATCD-B)	4
US Army Aviation Systems Command (AMSAV-ED, AMSAV-EI, AMSAV-EL, AMSAV-EA, AMSAV-EP, AMSAV-ES, AMSAV-Q, AMSAV-MC, AMSAV-ME)	11
US Army Test and Evaluation Command (AMSTE-CT-A, AMSTE-TO-O)	2
US Army Logistics Evaluation Agency (DALO-LEI)	1
US Army Materiel Systems Analysis Agency (AMXSY-R, AMXSY-MP)	2
US Army Operational Test and Evaluation Agency (CSTE-ASD-E)	1
US Army Armor Center (ATZK-CD-TE)	1
US Army Aviation Center (ATZQ-D-T, ATZQ-TSM-A, ATZQ-TSM-S, ATZQ-TSM-U)	4
US Army Combined Arms Center (ATZLCA-DM)	1
US Army Safety Center (PESC-Z, PESC-Library)	2
US Army Research and Technology Laboratories (AVSCOM) (SAVDL-AS, SAVDL-POM (Library))	2
US Army Research and Technology Laboratories/Applied Technology Laboratory (SAVDL-ATL-D, SAVDL-Library)	2
US Army Research and Technology Laboratories/Aeromechanics Laboratory (AVSCOM) (SAVDL-AL-D)	1

US Army Research and Technology Laboratories/Propulsion	
Laboratory (AVSCOM) (SAVDL-PL-D)	1
Defense Technical Information Center (DDR)	12
US Military Academy, Department of Mechanics	
(Aero Group Director)	1
MTMC-TEA (MTT-TRC)	1
ASD/AFXT, ASD/ENF	2
US Naval Post Graduate School. Department Aero Engineering	1
(Professor Donald Layton)	
Assistant Technical Director for Projects, Code: CT-24	
(Mr. Joseph Dunn)	2
6520 Test Group (ENML/Stop 238)	1
Commander, Naval Air Systems Command (AIR 5115B, AIR 5301)	3
Product Manager, Special Electronic Mission Aircraft	
(AMCPM-AET)	3
Project Manager, Black Hawk (AMCPM-BH-QT)	2
Project Manager, Aircraft Survivability Equipment	
(AMCPM-ASE-PA&T)	2
ESL Incorporated (Mr. Hal Millering)	2

**END**

**FILMED**

**9-85**

**DTIC**