

AD-A157 777

APPLICATION OF PASTERNAK MODEL TO SOME SOIL-STRUCTURE
INTERACTION PROBLEM. (U) KERR (ARNOLD D) WILMINGTON DE
A D KERR MAY 85 WES/TR/K-85-1-VOL-2 DACN39-83-M-1533

1/1

UNCLASSIFIED

F/G 13/13

NL

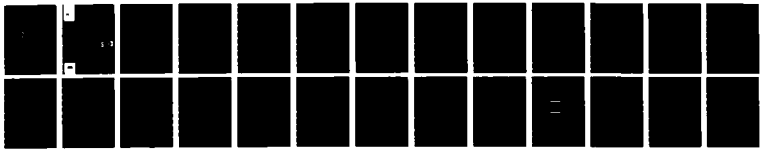

END

FILMED

DTIC

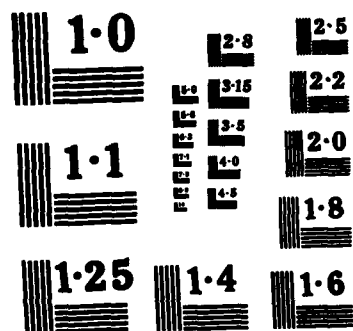

NATIONAL BUREAU OF STANDARDS
MICROCOPY RESOLUTION TEST CHART

TECHNICAL REPORT K-85-1

APPLICATION OF PASTERNAK MODEL TO SOME SOIL-STRUCTURE INTERACTION PROBLEMS

Volume II DETERMINATION OF FOUNDATION PARAMETERS AND THE CHOICE OF MODELS

by
Arnold D. Kerr
903 Overbrook Road
Wilmington, Delaware 19807



DTIC
ELECTE
JUL 19 1985
S **D**
G

May 1985
Final Report

Approved For Public Release; Distribution Unlimited

Prepared for DEPARTMENT OF THE ARMY
US Army Corps of Engineers
Washington, DC 20314-1000

Under Contract No. DACW 39-83-M-1533

Monitored by Automation Technology Center
US Army Engineer Waterways Experiment Station
PO Box 631, Vicksburg, Mississippi 39180-0631

85 6 28 035



US Army Corps
of Engineers

AD-A157 777

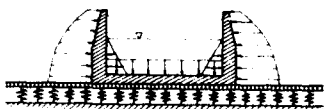
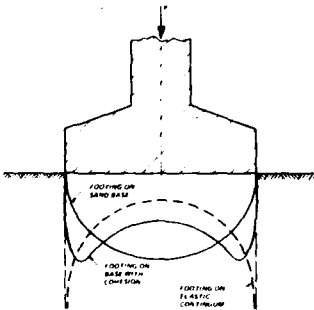
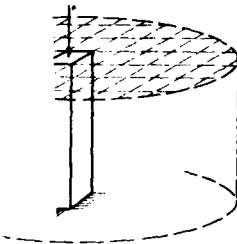
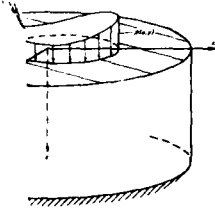

AUTOMATION
TECHNOLOGY CENTER

Destroy this report when no longer needed. Do not return it to the originator.

The findings in this report are not to be construed as an official Department of the Army position unless so designated by other authorized documents.

Accession For	
NTIS GRA&I	<input checked="" type="checkbox"/>
DTIC TAB	<input type="checkbox"/>
Unannounced	<input type="checkbox"/>
Justification	
By _____	
Distribution/	
Availability Codes	
Dist	Avail and/or Special
Ah	

The contents of this report are not to be used for advertising, publication, or promotional purposes. Citation of trade names does not constitute an official endorsement or approval of the use of such commercial products.



Unclassified

SECURITY CLASSIFICATION OF THIS PAGE (When Data Entered)

REPORT DOCUMENTATION PAGE		READ INSTRUCTIONS BEFORE COMPLETING FORM
1. REPORT NUMBER Technical Report K-85-1	2. GOVT ACCESSION NO.	3. RECIPIENT'S CATALOG NUMBER
4. TITLE (and Subtitle) APPLICATION OF PASTERNAK MODEL TO SOME SOIL- STRUCTURE INTERACTION PROBLEMS; Volume II: Determination of Foundation Parameters and the Choice of Models	5. TYPE OF REPORT & PERIOD COVERED Final Report	
	6. PERFORMING ORG. REPORT NUMBER	
7. AUTHOR(s) Arnold D. Kerr	8. CONTRACT OR GRANT NUMBER(s) Contract No. DACW 39- 83-M-1533	
9. PERFORMING ORGANIZATION NAME AND ADDRESS Dr. Arnold D. Kerr 903 Overbrook Road Wilmington, Delaware 19807	10. PROGRAM ELEMENT, PROJECT, TASK AREA & WORK UNIT NUMBERS	
11. CONTROLLING OFFICE NAME AND ADDRESS DEPARTMENT OF THE ARMY US Army Corps of Engineers Washington, DC 20314-1000	12. REPORT DATE May 1985	
	13. NUMBER OF PAGES 22	
14. MONITORING AGENCY NAME & ADDRESS (if different from Controlling Office) US Army Engineer Waterways Experiment Station Automation Technology Center PO Box 631, Vicksburg, Mississippi 39180-0631	15. SECURITY CLASS. (of this report) Unclassified	
	15a. DECLASSIFICATION/DOWNGRADING SCHEDULE	
16. DISTRIBUTION STATEMENT (of this Report) Approved for public release; distribution unlimited.		
17. DISTRIBUTION STATEMENT (of the abstract entered in Block 20, if different from Report)		
18. SUPPLEMENTARY NOTES Available from National Technical Information Service, 5285 Port Royal Road, Springfield, Virginia 22161.		
19. KEY WORDS (Continue on reverse side if necessary and identify by block number) Foundations--methodology (LC) Pasternak foundation model (WES) Plates (Engineering) (LC) Soil mechanics (LC) Structural engineering (LC)		
20. ABSTRACT (Continue on reverse side if necessary and identify by block number) This study is reported in two volumes concerning the analyses of continu- ously supported structures and their foundation responses. Volume II gives methods of parameter determination of foundation models for use in supported-structure analyses. Four methods for determining these parameters are discussed in detail. Though the last of these, Method IV, has gained reputable comments concerning its calculation of model parameters, the (Continued)		

Unclassified

SECURITY CLASSIFICATION OF THIS PAGE (When Data Entered)

Unclassified

SECURITY CLASSIFICATION OF THIS PAGE(When Data Entered)

20. ABSTRACT (Continued).

author exposes this method as conceptually invalid, contrary to its acceptance and recognition. The proper methods for determining suitable foundation models and their corresponding parameters are offered.

Volume I documents research for the Pasternak Base model and its implementation for design of hydrotechnical structures. Solutions are offered for a variety of plates subjected to the different loading conditions common to Corps of Engineers structures.

Unclassified

SECURITY CLASSIFICATION OF THIS PAGE(When Data Entered)

PREFACE

This is the second of two volumes dealing with soil-structure interaction models. Volume II discusses criteria for choosing suitable foundation models. It presents thoughts on different procedures for selecting the independent parameters for any soil-structure interaction model. The first volume presents a Pasternak Base model and its use for design of hydrotechnical structures.

The report was prepared by Dr. Arnold D. Kerr, P.E., Wilmington, Delaware, under Contract No. DACW 39-83-M-1533. The work in producing this report was accomplished with funds provided to the US Army Engineer Waterways Experiment Station (WES), Vicksburg, Miss., by the Civil Works Research and Development Program of the Office, Chief of Engineers (OCE), under the Soil-Structure Interaction (SSI) Studies Project of the Structural Engineering Research Program Work Unit.

Dr. N. Radhakrishnan, Chief, Automation Technology Center (ATC), coordinated and provided objectives for the work. Dr. Robert L. Hall, Research Group, Scientific and Engineering Application Division, ATC, monitored the work. Mr. Donald R. Dressler was the point of contact in OCE.

Commanders and Directors of WES during the research and publication of this report were COL Tilford C. Creel, CE, and COL Robert C. Lee, CE. Technical Director was Mr. F. R. Brown.

CONTENTS

	<u>Page</u>
PREFACE	1
PART I: INTRODUCTION	3
Background	3
Purpose and Scope	3
PART II: DERIVATION OF FOUNDATION MODEL PARAMETERS AS FUNCTIONS OF THE CONSTANTS E , ν OF AN ELASTIC LAYER	5
The Reissner Foundation Response	5
Derivation of the Pasternak Foundation Response from the Equations of an Elastic Layer	6
Derivation of the Winkler Foundation Response from the Equations of an Elastic Layer	9
PART III: COMMENTS TO THE DETERMINATION OF THE MODEL PARAMETERS FROM THE DERIVED FOUNDATION RESPONSE EXPRESSIONS	11
Horvath Approach	11
Procedures Proposed by Horvath and Other Researchers Conceptually Invalid	11
Demonstration Indicates Value Differences in Original Continuum and Simplifying Assumptions	14
PART IV: PRINCIPLES FOR CHOOSING FOUNDATION MODELS AND METHODS FOR DETERMINING THE NECESSARY PARAMETERS	15
General Considerations	15
Remarks on the Determination of Foundation Parameters	16
Remarks on the Choice of a Proper Foundation Model	17
REFERENCES	21

APPLICATION OF PASTERNAK MODEL TO SOME SOIL-STRUCTURE INTERACTION PROBLEMS

DETERMINATION OF FOUNDATION PARAMETERS AND THE CHOICE OF MODELS*

PART I: INTRODUCTION

Background

1. When foundation models are used for the analysis of continuously supported structures that occur in engineering practice, a major difficulty encountered is the determination of the foundation parameter(s) which enter these analyses.

2. The four main methods for determining these parameters found in the literature are:

Method I The analytical results for the structure, like deflections or bending moments, that are based on the adopted simple foundation model, are compared with corresponding test data (References 1-4).

Method II The analytical results that are based on the adopted foundation model are compared with the corresponding analytical results for which the foundation model is an elastic continuum (References 5-9).

Method III In situ plate loading tests are used (References 10-17).

Method IV The foundation response expressions and, hence, the parameters are derived directly from the equations for an elastic continuum by introducing a priori simplifying assumptions regarding stresses and displacements (References 18-27) or by a formal power series expansion and retention of lower order terms (References 20, 28-30).

3. The fourth method has gained in popularity in recent years, since it suggests that the parameters of a simplified foundation model can be calculated from the constants E , n of an "equivalent" elastic continuum which are determined from laboratory tests on small soil samples taken from the layer(s) of the subgrade under consideration.

* Research supported by the US Army Engineer Waterways Experiment Station, Vicksburg, Miss. 39180.

Purpose and Scope

4. One aim of this paper is to show that the fourth method is conceptually of questionable validity and, thus, it should not be considered for the determination of foundation model parameters. The principal aim is to discuss the criteria for choosing suitable foundation models and the methods for determining the corresponding foundation parameters.

PART II: DERIVATION OF FOUNDATION MODEL PARAMETERS AS
FUNCTIONS OF THE CONSTANTS E , ν OF AN ELASTIC LAYER

5. According to Method IV, the derivation of simplified foundation response expressions from the equations of a continuum, by introducing a priori simplifying assumptions, directly yields the coefficients for the foundation response expressions in terms of the material parameters E , ν and the layer thickness H . These foundation response equations can be derived by any of the following three procedures:

Procedure 1 Using the differential equations for a continuum of finite depth, as done in References 18-22, or

Procedure 2 Using the variational approach, as done in References 23-27, or

Procedure 3 Using the formal approach by expanding in power series and retaining terms of lower order, as discussed in References 20 and 28-30.

6. For the following presentation, Method IV(1), which uses the differential equations for a continuum of finite depth, will be used because the made assumptions have a simple physical meaning. At first the relevant results obtained by E. Reissner^{18,19} are summarized. The equations which correspond to the Pasternak foundation and to the Winkler foundation are then derived. This is followed by a critique of the determination of the model parameters from the derived foundation response equations.

The Reissner Foundation Response

7. Consider an elastic layer of thickness H which rests on a rigid base and is subjected to a distributed load p , as shown in Figure 1. Assuming the simplifying assumptions

$$\left. \begin{aligned} \sigma_{xx}(x,y,z) &= \sigma_{yy}(x,y,z) = \sigma_{yx}(x,y,z) \equiv 0 \\ u(x,y,0) &= v(x,y,0) = 0 \\ u(x,y,H) &= v(x,y,H) = w(x,y,H) = 0 \end{aligned} \right\} \quad (1)$$

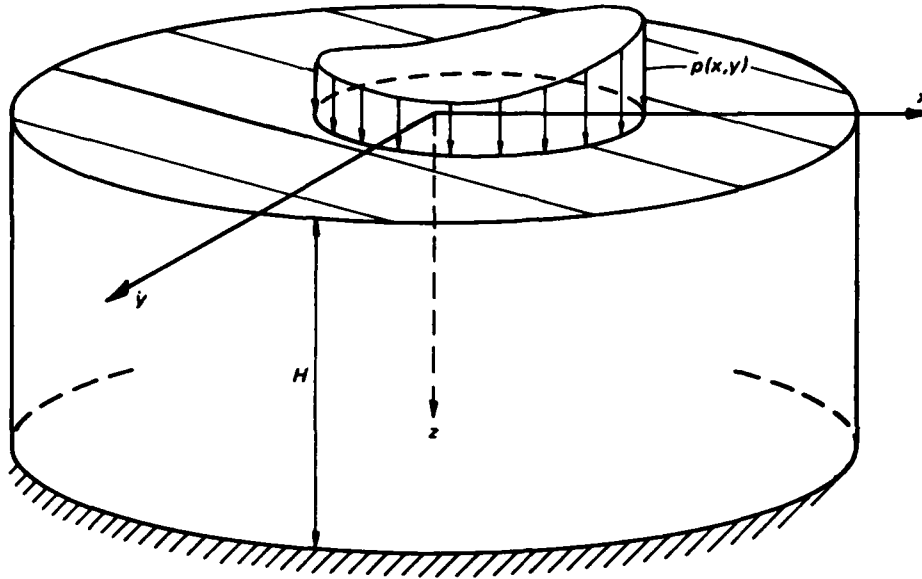

Figure 1. Elastic layer resting on a rigid base

where σ_{ij} are the stresses and (u,v,w) are the components of the displacement vector in the direction of (x,y,z) , Reissner derived the foundation response expression

$$p - \frac{H^2 G}{12E} \nabla^2 p = \frac{E}{H} w - \frac{HG}{3} \nabla^2 w \quad (2)$$

In the above equation $W(x,y) = w(x,y,0)$ is the vertical deflection of the free foundation surface and $p(x,y) = -\sigma_{zz}(x,y,0)$ is the distributed pressure normal to the free surface. A detailed derivation of Equation 2 was recently presented by Horvath²².

Derivation of the Pasternak Foundation Response from the Equations of an Elastic Layer

8. Consider the elastic layer shown in Figure 1 and assume that instead of Equation 1, the simplifying assumptions are

$$\left. \begin{aligned} \sigma_{xx}(x,y,z) = \sigma_{yy}(x,y,z) = \sigma_{yx}(x,y,z) &\equiv 0 \\ u(x,y,z) &\equiv 0 \quad ; \quad v(x,y,z) &\equiv 0 \end{aligned} \right\} \quad (3)$$

xt, we substitute these assumptions into the equilibrium equations, the stress-strain equations, and the strain-displacement relations for a linearly elastic solid and obtain

$$\frac{\partial \sigma_{xz}}{\partial z} = 0 \quad ; \quad \frac{\partial \sigma_{yz}}{\partial z} = 0 \quad ; \quad \frac{\partial \sigma_{zx}}{\partial x} + \frac{\partial \sigma_{zy}}{\partial y} + \frac{\partial \sigma_{zz}}{\partial z} = 0 \quad (4)$$

$$\left. \begin{aligned} \varepsilon_{xx} &= -\frac{\nu}{E} \sigma_{zz} & ; & \quad \varepsilon_{yy} = -\frac{\nu}{E} \sigma_{zz} & ; & \quad \varepsilon_{zz} = \frac{1}{E} \sigma_{zz} \\ \varepsilon_{xy} &= 0 & ; & \quad \varepsilon_{xz} = \frac{1}{2G} \sigma_{xz} & ; & \quad \varepsilon_{yz} = \frac{1}{2G} \sigma_{yz} \end{aligned} \right\} \quad (5)$$

$$\left. \begin{aligned} \varepsilon_{xx} &= 0 & ; & \quad \varepsilon_{yy} = 0 & ; & \quad \varepsilon_{zz} = \frac{\partial w}{\partial z} \\ \varepsilon_{xy} &= 0 & ; & \quad \varepsilon_{xz} = \frac{1}{2} \frac{\partial w}{\partial x} & ; & \quad \varepsilon_{yz} = \frac{1}{2} \frac{\partial w}{\partial y} \end{aligned} \right\} \quad (6)$$

9. The first two equations in Equations 5 and 6 imply that ν has to be assumed equal to zero and from the first two equations in Equation 4 it follows that, as in the Reissner foundation, the shearing stresses are independent of z . Thus,

$$\sigma_{xz} = \sigma_{xz}(x,y) \quad ; \quad \sigma_{yz} = \sigma_{yz}(x,y) \quad (7)$$

is an unrealistic result, especially for thick foundation layers. However, since foundation models are usually introduced to study the response of the foundation surface to applied loads, and not the stresses and displacements within the foundation material, this deficiency may, in general, be of no serious consequence.

10. Integrating the third part of Equation 4 with respect to z , noting Equation 7, we obtain

$$\sigma_{zz}(x,y,z) = -z \left(\frac{\partial \sigma_{zx}}{\partial x} + \frac{\partial \sigma_{zy}}{\partial y} \right) + f(x,y) \quad (8)$$

From the boundary condition

$$\sigma_{zz}(x,y,0) = -p(x,y) \quad (9)$$

it follows that

$$f(x,y) = -p(x,y) \quad (10)$$

and thus

$$\sigma_{zz}(x,y,z) = -p(x,y) - z \left(\frac{\partial \sigma_{zx}}{\partial x} + \frac{\partial \sigma_{zy}}{\partial y} \right) \quad (11)$$

11. Eliminating ε_{zz} from the third equation in Equations 5 and 6, we obtain

$$\frac{\partial w}{\partial z} = \frac{1}{E} \sigma_{zz} \quad (12)$$

Substituting Equation 11 into Equation 12, and then integrating the resulting equation with respect to z , we obtain, noting Equation 7,

$$E w(x,y,z) = -z p(x,y) - \frac{z^2}{2} \left(\frac{\partial \sigma_{zx}}{\partial x} + \frac{\partial \sigma_{zy}}{\partial y} \right) + g(x,y) \quad (13)$$

From the boundary condition

$$w(x,y,H) \equiv 0 \quad (14)$$

it follows that

$$g(x,y) = H p(x,y) + \frac{H^2}{2} \left(\frac{\partial \sigma_{zx}}{\partial x} + \frac{\partial \sigma_{zy}}{\partial y} \right) \quad (15)$$

and hence

$$E w(x,y,z) = (H - z) p(x,y) + \frac{H^2 - z^2}{2} \left(\frac{\partial \sigma_{zx}}{\partial x} + \frac{\partial \sigma_{zy}}{\partial y} \right) \quad (16)$$

According to Equations 5 and 6

$$\sigma_{zx} = G \frac{\partial w}{\partial z} \quad ; \quad \sigma_{zy} = G \frac{\partial w}{\partial y} \quad \text{and} \quad (17)$$

6. Frisch, H., and Simon, A. B., "Beitrag zur Ermittlung der Verticalen und Horizontalen Bettungsziffern," Die Bautechnik, Vol 51, No. 8, 1974; Discussion No. 7, 1978.
7. Weissmann, G. F., "Measuring the Modulus of Subgrade Soil Reaction," Materials Research and Standards, Vol 5, 1975, pp 71-75.
8. Reissner, E., "A Note on Deflection of Plates on a Viscoelastic Foundation," Journal of Applied Mechanics, Vol 25, 1958, pp 144-145.
9. _____, "Note on the Formulation of the Plate on an Elastic Foundation," Acta Mechanica, Vol 4, 1967, pp 88-91.
0. Kerr, A. D., and Rhines, W. J., "A Study of Elastic Foundation Models," S-67-1, 1967, New York University, Department of Aeronautics and Astronautics.
1. Horvath, J. S., "Modulus of Subgrade Reaction: New Perspective," Journal, Geotechnical Engineering, American Society of Civil Engineers, Vol 10, No. 12, 1983, pp 1591-1596.
2. _____, "New Subgrade Model Applied to Mat Foundations," Journal, Geotechnical Engineering, American Society of Civil Engineers, Vol 10, No. 12, 1983, pp 1567-1587.
3. Vlasov, V. Z., "Structural Mechanics of Thin Walled Three Dimensional Systems" (in Russian), Fizmatgiz, Moscow, USSR, 1949.
4. Vlasov, V. A., and Leontiev, N. N., "Beam, Plates and Sheels on Elastic Foundations" (in Russian), Fizmatgiz, Moscow, USSR, 1960; Translated into English as NASA TTF-357, 1966.
5. Kameswara Rao, N. S. V., Das, Y. C., and Anandkrishnan, M., "Variational Approach to Beams on Elastic Foundations," Journal, Engineering Mechanics Division, American Society of Civil Engineers, No. EM 2, 1971, pp 271-294.
6. Jones, R., and Xenophontos, J., "The Vlasov Foundation Model," International Journal of Mechanical Sciences, Vol 19, 1977.
7. _____, "On the Vlasov and Kerr Foundation Models," Acta Mechanica, Vol 25, 1976, pp 45-49.
8. Levinson, M., and Bharatha, S., "Elastic Foundation Models-A New Approach," Proceedings, 4th Symposium on Engineering Applications of Solid Mechanics, Ontario Research Foundation, Mississauga, Ontario, 1978.
9. Levinson, M., "On the Linear, Isotropic, Elastic Foundation of Grade 4," Mechanics Research Communication, Vol 6, No. 6, 1979, pp 369-378.
0. Kerr, A. D., "On the Formal Development of Elastic Foundation Models," Report CE-83-35, 1983, University of Delaware, Department of Civil Engineering, Newark, Del.
1. _____, "Elastic and Viscoelastic Foundation Models," Journal of Applied Mechanics, Vol 31, 1964.
2. _____, "A Study of a New Foundation Model," Acta Mechanica, Vol I/2, 1965.

REFERENCES

- Timoshenko, S., and Langer, B. F., "Stresses in Railroad Track," Journal of Applied Mechanics, American Society of Mechanical Engineers, Vol 54, 1932.
- Kerr, A. D., "On the Stress Analysis of Rails and Ties," Proceedings, AREA, Vol 78, 1976.
- _____, "Improved Stress Analysis for Cross-Tie Tracks," Journal, Engineering Mechanics Division, American Society of Civil Engineers, No. EM 4, 1979.
- _____, "A Method for Determining the Track Modulus Using A Locomotive or Car on Multi-Axle Trucks," Proceedings, AREA, 1983.
- Biot, M. A., "Bending of an Infinite Beam on an Elastic Foundation," Journal of Applied Mechanics, American Society of Mechanical Engineers, Vol 4, No. 1, 1937.
- Vesic, A. B., "Bending of Beams Resting on Isotropic Elastic Solid," Proceedings, American Society of Civil Engineers, Vol 87, No. EM 2, 1961.
- Vesic, A. B., and Johnson, W. H., "Model Studies of Beams Resting on Silt Subgrade," Journal, Soil Mechanics and Foundation, American Society of Civil Engineers, Vol 89, No. SM 1, 1963.
- Vardanyan, V. V., "K Teorii Rascheta Plit na Uprugom Osnovanii," ("To the Theory of Analyzing Plates on an Elastic Foundation," in Russian,) Teoriya Obolochek i Plastin, Trudy IV Vsesoyz. Konf. Izd. AN Armian SSR, Erevan, 1964.
- Fletcher, D. Q., and Hermann, L. R., "Elastic Foundation Representation of Continuum," Journal, Engineering Mechanics Division, American Society of Civil Engineers, No. EM 1, 1971.
- Teller, W., and Sutherland, E. C., "The Structural Design of Concrete Pavements," Public Roads, Vol 43, Part 5, 1943, pp 167-212.
- Brebner, A., and Wright, W., "An Experimental Investigation to Determine the Variation of Subgrade Modulus of Sand Loaded by Plates of Different Breadth," Geotechnique, Vol 3, 1952, pp 307-311.
- Terzaghi, K., "Evaluation of Coefficients of Subgrade Reaction," Geotechnique, Vol 5, No. 4, 1955, pp 297-326.
- Recordon, E., "Determination of Soil Characteristics Necessary for Foundation Calculations on Elastic Soils," Proceedings, 4th International Conference, Soil Mechanics and Foundation Engineering, Vol 1, 1957, pp 414-418.
- Nascimento, U., and Simoes, A., "Relation Between CBR and Modulus of Strength," Proceedings, 4th International Conference, Soil Mechanics and Foundation Engineering, Vol 2, 1957, pp 166-168.
- Nielson, F. D., Bhandhausavee, C., and Yeb, K. S., "Determination of Modulus of Soil Reaction from Standard Soil Tests," Highway Research Record 284, 1968, pp 1-12, Highway Research Board, National Academy of Sciences--National Research Council, Washington, D. C.

completed vertical walls, and then to analyze the walls and the continuously supported floor plate.

41. In the past, the Winkler foundation model was used to represent the response of the base. A major shortcoming of this model is that it does not represent correctly the vertical pressures along the edges (1) and (2). Thus, the resulting bending moments in the floor plate may deviate strongly from the actual ones.

42. To eliminate this shortcoming, either the Pasternak foundation or the Kerr foundation may be used. The corresponding models of the structure to be analyzed are shown in Figures 8 and 9.

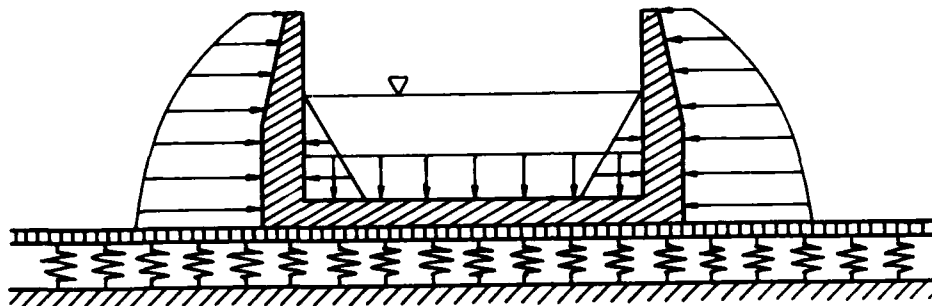

Figure 8. Lock on Pasternak foundation

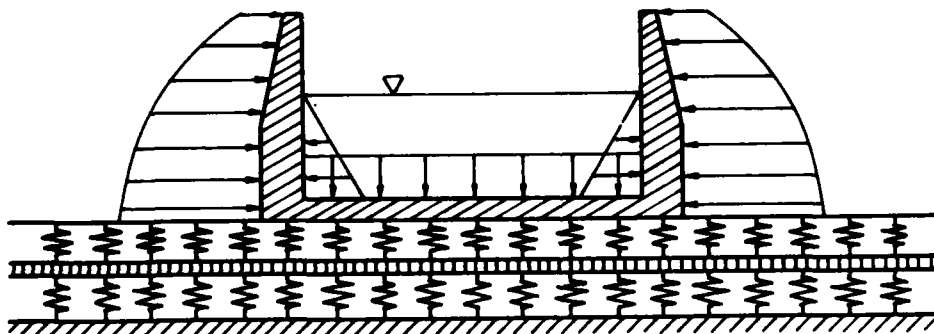

Figure 9. Lock on Kerr foundation

43. The above examples demonstrate that the choice of a foundation model depends on a variety of factors such as the geometry of the structure and the characteristics of the subgrade. In this connection it should be noted that the determination of foundation parameters is meaningless unless the chosen foundation model can represent the anticipated base response of interest.

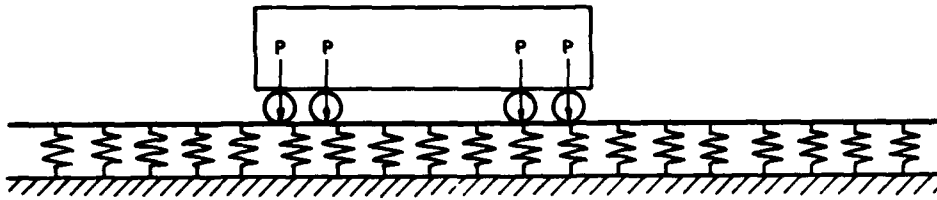

Figure 4. Model for railway track analysis

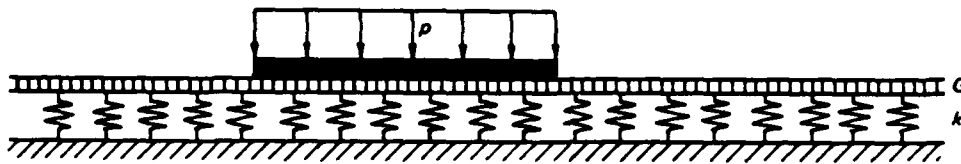

Figure 5. Plate on Pasternak foundation

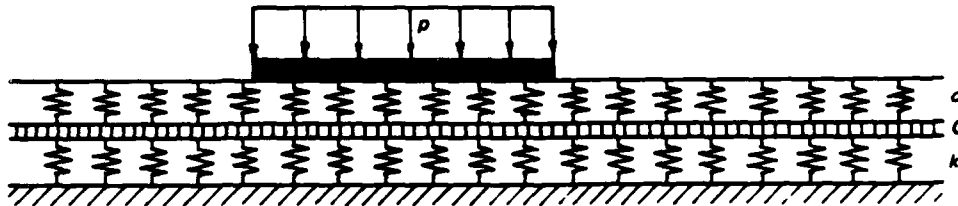

Figure 6. Plate on Kerr foundation

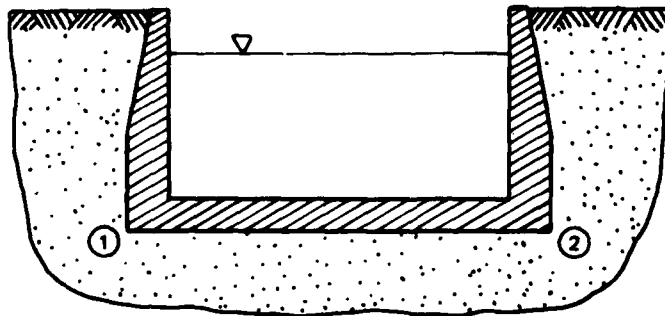

Figure 7. Lock structure

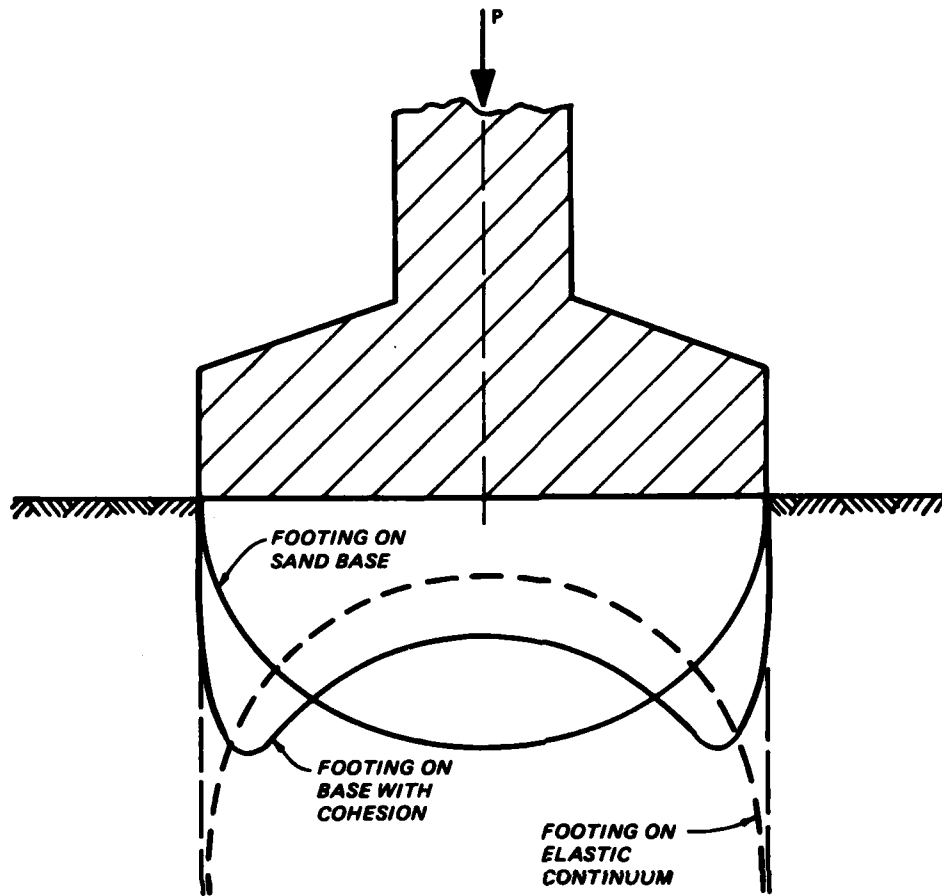

Figure 3. Contact pressure distribution

response (for example, contact pressure). This selection should be based on the established soil profiles of the location under consideration and the type of structure to be built. The chosen foundation model should incorporate the main feature of the anticipated response.

39. For example, the Winkler foundation represents the base response rather well for the analysis of railway tracks subjected to the static wheel loads of locomotives and cars, as shown in Figure 4, because the structure is very long. It is not suitable for representing the base response for a footing on a base with cohesion, as shown in Figure 3. In this case a more suitable foundation model is the one by Pasternak³¹ or Kerr,³² as shown in Figures 5 and 6.

40. In designing dock structures and navigation locks, structures of the type shown in Figure 7 are encountered. One approach for analyzing such structures is to estimate the largest net pressures to be expected on the

be used with caution, when applied to actual engineering problems.

32. The foundation parameters calculated using Method III, which is based on in situ plate loading tests, are useful only if the resulting analyses will predict the corresponding results anticipated in the field (like contact pressures) with a reasonable accuracy.

33. Method I, according to a collocation of analytical results based on a chosen foundation model with the corresponding test data, is the most suitable one. However, it requires the existence of the structure, or a large-scale model. This method is used for the determination of the modulus of railway tracks.⁴

34. It should be noted that the determination of foundation model parameters by analytical and tested collocation of surface deformations outside the loaded region is of questionable validity.

Remarks on the Choice of a Proper Foundation Model

35. The response equation is usually well known for the analysis of a continuously supported structure in geotechnical engineering. However, difficulties are encountered when choosing the response equations for the supporting base.

36. The reason for this is that the structure is made of a solid material (metal or reinforced concrete) and, while in service, it is expected to respond elastically when subjected to static and dynamic loads. On the other hand, the subgrade is generally a granular material, often with a variable degree of cohesion, and, hence, may easily undergo nonelastic deformations for any type of load.

37. To indicate the wide range of possible responses of a subgrade, Figure 3 shows two contact pressure distributions between a footing and its base as observed in tests. Note the large difference in the distributions when the base is a cohesionless sand or a base with cohesion. The contact pressure also varies substantially when the footing rests on top of the sand base, or is acting a few meters under the base surface. Note, also, that the elastic continuum predicts a very different pressure distribution from the one observed for a sand base.

38. Thus, in accordance with Step 2, when choosing a model for the subgrade it is essential to realize a priori the nature of the anticipated

Its task is to replace the defined physical problem of interest by an idealized (simplified) analytical model and then to derive the formulation for it. Many of the serious deficiencies of engineering analyses originate in this step. The response equations for continuously supported beam- or plate-type structures are well known. The problematics appear when choosing the response equations (model) for the supporting medium.

27. At this point it should be noted that an exact solution of a formulation yields the response of the *chosen model*, but not necessarily the response of the *actual structure*. Therefore, a desirable objective is to devise an analytical model for the structure and foundation whose response of interest is very close to the actual situation, and, at the same time, whose formulation is easily solvable.

28. Step 3 consists of the solution of the formulated problem and this is a mathematical exercise. For use in engineering practice, it is irrelevant whether the results are obtained in closed form or numerically using a computer method, if the numerical solution exhibits the desired degree of accuracy.

29. The purpose of Step 4 is to determine the parameters that enter the analysis and to validate the derived formulation, two tasks that are very closely related. They are usually performed by collocating the obtained analytical results with corresponding test data (Method I). This validation should determine whether or not the derived formulation represents the problem under consideration with the desired degree of accuracy, including a wide range of parameters which may be encountered in engineering practice; the wider the range of parameters the better the model.

Remarks on the Determination of Foundation Parameters

30. In Part III it was shown that Method IV is not suitable for the determination of foundation parameters used in engineering practice.

31. Regarding Method II, it should be noted that the determination of foundation parameters from a collocation of a solution based on a simple foundation model with the corresponding solution based on an elastic continuum is often only of academic interest. This is so because there are many situations in geotechnical engineering for which the elastic continuum is not suitable for representing the base response (for example, footings on sand). Therefore, the foundation parameters determined by using Method II, should also

**PART IV: PRINCIPLES FOR CHOOSING FOUNDATION MODELS AND METHODS
FOR DETERMINING THE NECESSARY PARAMETERS**

General Considerations

24. To begin this discussion let us first review the general procedure for obtaining analytical solutions to physical problems. This procedure consists essentially of four distinct steps, which are shown in the following tabulation:

<u>Step 1</u>	<u>Step 2</u>	<u>Step 3</u>	<u>Step 4</u>
<p>DEFINITION OF PHYSICAL PROBLEM to be analyzed</p> <p><u>For example:</u> Determination of contact stresses and bending moments in a footing.</p>	<p>FORMULATION OF THE PROBLEM (Mechanics)</p> <p>1. Choice of an idealized model</p> <p>2. Analytical formulation of model</p> <p>Result: Equations</p>	<p>SOLUTION OF FORMULATION (Mathematics)</p> <p>1. Analytical solution or</p> <p>2. Numerical solution</p>	<p>DETERMINATION OF PARAMETERS AND VALIDATION by comparing with results of relevant tests</p> <p>(If agreement is poor, return to Step 2.)</p>

25. Step 1, although superficially obvious, is a very essential step and certainly not a trivial one. This is true because a very general formulation, containing a large range of information, is usually difficult to derive and even more difficult and costly to solve. Therefore, in engineering, as in the various branches of the physical sciences, it is often necessary to limit the range of answers of interest to be obtained from an analysis, in order to simplify the resulting formulation and solution (namely, Steps 2 and 3). In this approach, if more than one answer for the same structure is needed it may require more than one formulation. As an example, note that the analysis of a structure and its foundation should be based on one formulation, which contains the equations for the structure and the equations for the foundation. However, in order to simplify the necessary analysis, often this problem is separated into two parts: (a) a structure that rests on a simple foundation model and (b) a continuum foundation that is subjected to the structural forces determined from part (a).

26. Step 2 is usually the most crucial and intricate of the four steps.

Demonstration Indicates Value Differences in Original
Continuum and Simplifying Assumptions

22. To demonstrate this point consider an analogous situation of a thin elastic plate that is governed by the differential equation for the deflections $w(x,y)$,

$$D\nabla^4 w = q \quad (30)$$

where

$$D = \frac{Eh^3}{12(1 - \nu^2)} \quad (31)$$

is the bending stiffness of the plate, h is the thickness of the plate, and (E, ν) are the elastic constants of the plate material. Assume that, at some instant, the plate becomes penetrated by a dense net of randomly distributed fine cracks (possibly, due to shrinkage of the concrete). It is easy to realize that, in this new state, the "effective" bending stiffness D of the cracked plate is lower than the original value; the reduction depending on the density and type of the crack pattern. Since the plate thickness h did not change due to the fine cracks, it follows from Equation 31 that the "effective" E and ν differ from the original values. The fine crack pattern in the plate problem is analogous to the simplifying assumptions made when deriving the foundation response expressions from the equations of an elastic continuum. Thus, the E and ν values of the "continuum" that is subjected to the simplifying assumptions are not the same as those of the original continuum.

23. The above discussion suggests that the procedure for determining the foundation modulus as proposed by Horvath,²¹ as well as by some other researchers who used Method IV, is generally not suitable for determining the foundation parameters for use in engineering practice.

19. Next, consider the nonhomogeneous foundation discussed by Horvath,²¹ namely when $E = \alpha + \beta z$; α and β being constants. Also, for this case, differential Equation 24 can be integrated directly to yield

$$w(z) = \frac{B_1}{A} \int \frac{1}{\alpha + \beta z} dz + B_2$$

Setting $\alpha + \beta z = \zeta$ and nondimensionalizing the denominator, it follows that

$$w(z) = \frac{B_1}{\beta A} \int \frac{1}{\frac{\zeta}{\alpha}} d\left(\frac{\zeta}{\alpha}\right) + B_2 = \frac{B_1}{\beta A} \ln [(\alpha + \beta z)/\alpha] + B_2$$

The integration constants B_1 and B_2 are determined from the boundary conditions in Equation 25. The resulting displacement expression is

$$w(z) = \frac{P}{\beta A} \ln \frac{\alpha + \beta H}{\alpha + \beta z} \quad 0 \leq z \leq H \quad (28)$$

At $z = 0$, with $P/A = p$ and $w = W$, Equation 28 can be written as

$$p = \frac{\beta}{\ln [(\alpha + \beta H)/\alpha]} W \quad (29)$$

This expression is the same as Equation 27, except for the coefficient of W . The coefficient of W is identical to the k_{sc} expression given in Reference 21, Equation 9a, for $E = \alpha + \beta z$, which was derived from the "simplified continuum procedure."

20. The above derivations, Equations 24-29, demonstrate that E/H and $\beta/\ln [(\alpha + \beta H)/\alpha]$ are the k -values for a simple column of height H . Thus, each is the foundation modulus for a base that consists of closely spaced independent vertical columns (springs). However, this does not imply that each is the foundation modulus k for a truly continuous base, as encountered in engineering practice.

21. When reviewing attempts to determine foundation parameters from the constants E, ν of an elastic continuum, as indicated in Equation 20 or 23, it has to be noted that the introduction of simplified assumptions, of the type stated in Equation 1, 3, or 21, changes the nature of the continuum, and affects the constants E and ν .

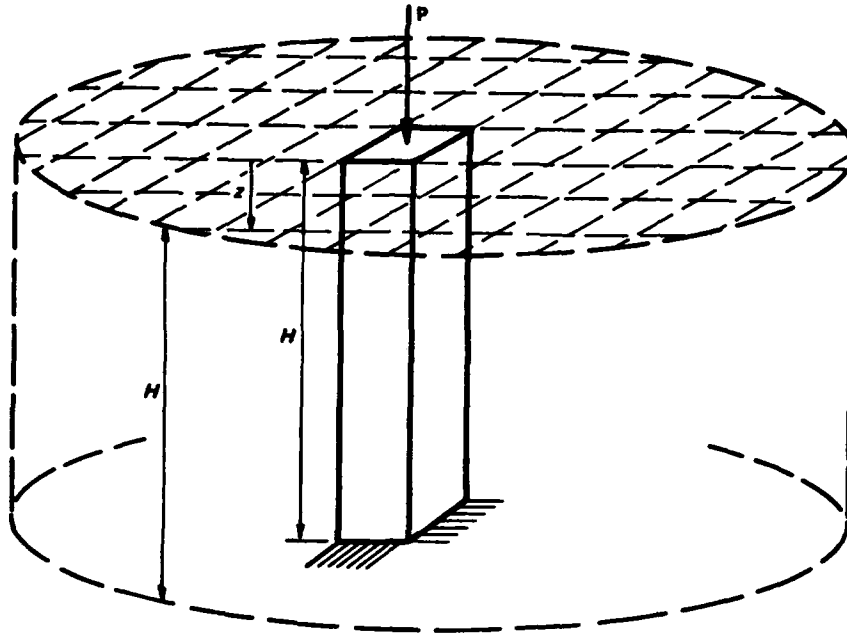

Figure 2. Foundation layer consisting of closely spaced vertical columns

$$\frac{d}{dz} \left(EA \frac{dw}{dz} \right) = 0 \quad (0 \leq z \leq H) \quad (24)$$

and the boundary conditions

$$\left. \begin{aligned} w'(0) &= - (P/EA)_{z=0} \\ w(H) &= 0 \end{aligned} \right\} \quad (25)$$

In above formulation $w(z)$ is the vertical displacement at z , A is the cross-sectional area of the column, and E is Young's modulus of the column material.

18. For the case when $EA = \text{constant}$, the above formulation yields

$$w(z) = \frac{P(H - z)}{EA} \quad (26)$$

At $z = 0$, with $P/A = p$ and $w = W$, Equation 26 can be written as

$$p = \frac{E}{H} W \quad (27)$$

which is identical with Equation 22.

PART III: COMMENTS TO THE DETERMINATION OF THE MODEL PARAMETERS
FROM THE DERIVED FOUNDATION RESPONSE EXPRESSIONS

Horvath Approach

15. The parameter expressions of the type given in Equations 20 and 23 led a number of researchers to the conclusion that the foundation model parameters may be calculated from the constants E, ν of an equivalent elastic continuum, which are determined from laboratory tests on samples taken from the actual base. The most recent example of this approach is described in the paper by Horvath.²¹ He derived the foundation response expression

$$p(x,y) = \frac{E}{H} W(x,y) \quad (22')$$

as indicated in paragraph 12, noted that the above equation is identical to the Winkler foundation response when the Winkler parameter is

$$k = \frac{E}{H} \quad (23')$$

and then suggested "...that k can be interpreted and evaluated using an approach that has as its basis the theory of elasticity..." and thus, that "...it is possible to evaluate k from known soil parameters..." E, ν and the layer thickness H , using Equation 23.

Procedures Proposed by Horvath and Other
Researchers Conceptually Invalid

16. It is the opinion of this writer that the above procedure proposed by Horvath²¹ is conceptually of questionable validity. This applies also to similar suggestions made by some of the other researchers who used Method IV. (This objection does not apply to the determination of foundation parameters in terms of E, ν used in Method II, which is based on a different concept.)

17. To illustrate this point, note that the simplifying assumptions in Equation 21 suggest that the foundation layer consists of closely spaced vertical columns of length H , as shown in Figure 2, that are not interconnected. The standard analytical formulation of these columns consists of the differential equation

$$\varepsilon_{zz} = \frac{\partial w}{\partial z} \quad (6')$$

with the stipulation that $v = 0$, as in the previous section.

14. Proceeding as before, we obtain for the free surface of the foundation, instead of Equation 19, the response expression

$$p(x,y) = \frac{E}{H} W(x,y) \quad (22)$$

This expression is identical to the response equation of the Winkler foundation, if we set

$$k = \frac{E}{H} \quad (23)$$

noting above relations, Equation 16 assumes the form

$$E w(x,y,z) = (H - z) p(x,y) + \frac{G}{2} (H^2 - z^2) \nabla^2 w \quad (18)$$

where $\nabla^2 = \partial^2/\partial x^2 + \partial^2/\partial y^2$ is the Laplace operator.

12. At the free surface of the foundation $z = 0$ and Equation 18 becomes, setting $w(x,y,0) = W(x,y)$

$$p(x,y) = \frac{E}{H} W - \frac{GH}{2} \nabla^2 W \quad (19)$$

This expression is identical to the response equation of the Pasternak foundation,³¹ if the two foundation parameters are set

$$k_p = \frac{E}{H} \quad ; \quad G_p = \frac{GH}{2} \quad (20)$$

Derivation of the Winkler Foundation Response from the Equations of an Elastic Layer

13. Consider again the elastic layer shown in Figure 1, but assume, instead of Equation 3, the simplifying assumptions, that throughout the foundation

$$\left. \begin{aligned} \sigma_{xx} = \sigma_{yy} = \sigma_{xy} = \sigma_{xz} = \sigma_{yz} &\equiv 0 \\ u = v &\equiv 0 \end{aligned} \right\} \quad (21)$$

With these assumptions the equilibrium, stress-strain, and strain-displacement relations for the elastic layer reduce to the following necessary equations:

$$\frac{\partial \sigma_{zz}}{\partial z} = 0 \quad (4')$$

$$\varepsilon_{zz} = \frac{\sigma_{zz}}{E} \quad (5')$$

END

FILMED

9-85

DTIC