

NATIONAL BUREAU OF STANDARDS
MICROCOPY RESOLUTION TEST CHART



National Defence
 Research and
 Development Branch

Défense Nationale
 Bureau de Recherche
 et Développement

①

AD-A158 036

TECHNICAL MEMORANDUM 85/204
 May 1985

THE CALCULATION OF
 POTENTIAL FLOW
 ABOUT SHIP HULLS

MICHAEL MACKAY & DAVID HALLY

DTIC FILE COPY

**Defence
 Research
 Establishment
 Atlantic**



**Centre de
 Recherches pour la
 Défense
 Atlantique**

DTIC
 ELECTED
 AUG 19 1985

This document has been approved
 for public release and sale; its
 distribution is unlimited.

Canada

AV

85 8 15 030

TERMS OF RELEASE

THIS DOCUMENT CONTAINS PROPRIETARY INFORMATION. IT IS FURNISHED IN CONFIDENCE AND WITH THE EXPRESS UNDERSTANDING THAT PROPRIETARY AND PATENT RIGHTS WILL BE RESPECTED.

PLEASE ADDRESS FURTHER ENQUIRIES TO:

THE CHIEF,
DEFENCE RESEARCH ESTABLISHMENT ATLANTIC,
P.O. BOX 1012, DARTMOUTH, N.S., B2Y 3Z7
CANADA.

A1

DEFENCE RESEARCH ESTABLISHMENT ATLANTIC

9 GROVE STREET

P.O. BOX 1012
DARTMOUTH, N.S.

B2Y 3Z7



TELEPHONE
(902) 426-3100

CENTRE DE RECHERCHES POUR LA DÉFENSE ATLANTIQUE

9 GROVE STREET

C.P. 1012
DARTMOUTH, N.É.
B2Y 3Z7



National Defence
Research and
Development Branch

Défense Nationale
Bureau de Recherche
et Développement

THE CALCULATION OF
POTENTIAL FLOW
ABOUT SHIP HULLS

MICHAEL MACKAY & DAVID HALLY

MAY 1985

Approved by B.F. Peters A/Director/Technology Division

DISTRIBUTION APPROVED BY

A/D/TD

TECHNICAL MEMORANDUM 85/204

Defence
Research
Establishment
Atlantic



Centre de
Recherches pour la
Défense
Atlantique

Canada

Abstract

This memorandum is the second of three which describe a series of computer programs for the calculation of the growth of a boundary layer on a ship hull. The first described computer programs for the numerical approximation of ship hulls using smoothing splines. This memorandum describes the calculation of the potential flow around the numerically approximated hulls. The third memorandum will describe the calculation of the boundary layer growth.

The potential flow is calculated using a first-order panel method which yields the cartesian components of the flow vector at a number of control points on the hull. These discrete cartesian flow vectors are converted to contravariant velocity components and splined to yield a continuous representation of the potential flow over the hull. Zero Froude number is assumed.

User guides are given for programs implementing the panel method and for a program which splines the calculated velocities.

Keywords: Hydrodynamics, Ship Hulls, Boundary Layer Growth, Potential Flow, Panel Method, Velocity Spline

Résumé

Le présent mémoire est le deuxième de trois mémoires qui décrivent une série de programmes informatiques permettant de calculer la croissance d'une couche limite sur une coque de bateau. Le premier décrivait des programmes informatiques d'approximation numérique des coques de bateau à partir de fonctions splines de lissage. Ce deuxième porte sur le calcul de l'écoulement potentiel autour des coques approchées numériquement. Le troisième portera sur le calcul de la croissance des couches limites.

L'écoulement potentiel est établi au moyen d'une méthode de panneaux de premier ordre qui donne les composantes cartésiennes du vecteur d'écoulement en certains points de contrôle de la coque. Ces vecteurs d'écoulement cartésiens discrets sont transformés en composantes de vitesse, lesquelles sont lissées par fonctions splines en une représentation continue de l'écoulement potentiel autour de la coque. On suppose un nombre de Froude nul.

Des guides de l'utilisation sont distribués; ils portent sur les programmes d'application de la méthode des panneaux et sur un programme de lissage par splines des vitesses calculées.

Table of Contents

Section	Page
Abstract	i
NOMENCLATURE	v
1. INTRODUCTION	1
2. HULL REPRESENTATION AND COORDINATE SYSTEM	3
3. CALCULATION OF THE DISCRETE CARTESIAN POTENTIAL FLOW	4
4. COMPRESSIBILITY CORRECTION FOR POTENTIAL FLOW	6
5. SPLINING THE DISCRETE CARTESIAN POTENTIAL FLOW	6
5.1 REPRESENTATION OF THE VELOCITY VECTOR IN HULL COORDINATES	6
5.2 SPLINING THE CONTRAVARIANT VELOCITY COMPONENTS	7
5.2.1 REPRESENTATION OF THE VELOCITY IN TERMS OF B-SPLINES	8
5.2.2 EVALUATION OF THE SPLINE COEFFICIENTS	8
5.3 END POINT CONDITIONS FOR THE SPLINES	9
6. CONCLUDING REMARKS	9
Appendix	Page
A. USER'S GUIDES FOR THE EN967 PROGRAMS	15
A.1 USER'S GUIDE FOR EN967S	15
A.1.1 OPERATION OF EN967S	16
A.1.2 OUTPUT FROM EN967S	17
A.2 USER'S GUIDE FOR EN967C	18
A.2.1 OPERATION OF EN967C	19
A.2.2 OUTPUT FROM EN967C	19
A.3 USER'S GUIDE FOR EN967D	20
A.3.1 OPERATION OF EN967D	20
A.3.2 OUTPUT FROM EN967D	20
A.4 USER'S GUIDE FOR EN967E	21
A.4.1 OPERATION OF EN967E	21
A.4.2 OUTPUT FROM EN967E	21
A.5 SUMMARY OF OPERATING PROCEDURE FOR EN967C/D/E	22
B. USER'S GUIDE FOR VELSPL	28
B.1 TERMINALS AND PLOTTERS	28
B.1.1 IDENTIFYING TERMINAL AND PLOTTER TYPE	28
B.1.2 SET UP OF 4662 AND 4663 PLOTTERS	29

B.2	COMMAND LANGUAGE IN VELSPL	30
B.3	INITIAL INPUT	31
B.4	SPLINING WITH DEFAULTS	31
B.5	CHANGING THE DEFAULTS	33
B.5.1	CHANGING THE AMOUNT OF SMOOTHING	34
B.5.2	CHANGING THE DATA POINT ERRORS	34
B.5.3	CHANGING THE ORDER OF THE SPLINES	35
B.5.4	CHANGING THE KNOTS	36
B.5.5	CHANGING THE STIFFNESS WEIGHTS	37
B.5.6	CHANGING THE SMOOTHING DERIVATIVE	38
B.5.7	CHANGING THE TERMINAL AND PLOTTER TYPE	38
C.	CALCULATING STREAMLINES FROM CONTRAVARIANT VELOCITY COMPONENTS	39
References		40
Subject Index		41

NOMENCLATURE

- a_{ij} - element of influence coefficient matrix
- $B_{p,k}$ - the p^{th} B-spline of order k
- e_p - hull surface vector, basis for contravariant vectors
- e^n - hull surface vector, basis for covariant vectors
- k_x, k_s - orders of splines in the x and s directions respectively
- N_x, N_s - number of B-splines in the x and s directions respectively
- M_∞ - freestream Mach number
- n - normal to a boundary or panel
- P_{CP} - panel control point
- P_i - corner points of non-planar panel ($i = 1, \dots, 4$)
- P'_i - corner points of planar panel ($i = 1, \dots, 4$)
- P_N - Planar panel definition point
- r - displacement vector between two points
- r - distance between two points. The magnitude of r .
- S - boundary of the domain Ω
- $t_p^{(x)}, t_q^{(s)}$ - knot sequences for splines in x and s directions respectively
- T - solid angle normalized by 4π
- T_1, T_2 - vectors joining the corners of the planar panel
- V - local velocity vector
- V_∞ - free stream velocity
- γ^k - contravariant component of V
- x, s - non-orthogonal surface coordinate system

- x',y',z' - cartesian coordinate system used in EN967
- X,Y,Z - cartesian coordinate system used in SMHULL
- α_{pq}, β_{pq} - B-spline coefficients for Y and Z respectively
- λ_{pq}^k - B-spline coefficients for V^k
- μ_q^k - B-spline coefficient defined in equation (5.7)
- σ - source density
- Φ - velocity potential
- Ω - flow region, or domain

ABBREVIATIONS

- AP - aft perpendicular
- FP - forward perpendicular
- LBP - length between perpendiculars

BOLD CHARACTERS

Bold characters are reserved for vectors.

SUBSCRIPTS

Subscripts i and j are generally associated with the discretized flow model. Thus, V_i is the local velocity at the i^{th} control point NOT the i^{th} component of the velocity vector.

Subscripts k and n are generally associated with the covariant and contravariant coordinates of vectors and the basis vectors for the hull coordinate system. Thus V^k is the k^{th} contravariant component of vector V and e^k is the k^{th} contravariant basis vector.

1 INTRODUCTION

This memorandum is the second of three which present programs leading to the prediction of boundary layers starting from hull section offsets. The purpose of the programs EN967 and VELSPH described here is to calculate the velocity field of a steady, incompressible, potential flow around a ship hull whose geometry has been specified by the program SMHULL¹. This flow field may then be used as input to the program BLAYER² which calculates the boundary layer growth on the hull. Figure illustrates how the programs described here fit into the overall boundary layer calculation. Since input data for the programs described here must be pre-processed using the programs described in the first report published¹, a reasonable level of familiarity with that document is assumed.

Fluid flow is described as a potential flow when the velocity field is the gradient of a scalar potential. Such a flow is irrotational since the vorticity vanishes everywhere. If the flow is also incompressible, the scalar potential is governed by Laplace's equation and may be determined uniquely if appropriate boundary conditions are specified. The boundary conditions appropriate for the flow past a ship moving at constant speed are that the flow at infinity be uniform and that there is no flux of fluid through the hull of the ship. An additional simplification is made by assuming the Froude number to be zero; that is, there is no wavemaking, and the free surface is replaced by a rigid, reflecting surface. This approximation is satisfactory except very near the surface and considerably simplifies the subsequent boundary layer calculation. The flow thus calculated gives a good approximation to the flow around a ship hull outside the boundary layer, and, where the boundary layer is considered 'thin' (a reasonable assumption over the greater part of a ship hull), may be used to predict dynamic pressures and streamlines with acceptable accuracy. It is used in the present instance to provide surface velocities for a boundary layer prediction method.

The calculation of the incompressible potential flow around a hull can be broken into two main steps. The flow is first calculated using a first order panel method which yields values of the velocity vector at prescribed control points on the hull. The velocity vectors are given in cartesian coordinates. When used for subsequent calculations this discrete cartesian representation of the potential flow is often not convenient, for three reasons.

- 1) It may be necessary to know the potential flow at points other than the control points. Some means of interpolation is then required.
- 2) Since the hull form is known, only two components of the flow vector are needed to determine it uniquely. Hence the flow vectors are overdetermined, since the cartesian representation uses three components to represent the flow vectors.
- 3) The cartesian coordinate system is not often used in calculations involving the potential flow. Transformations between different coordinate systems are then necessary.

To avoid these difficulties, the second calculation step is invoked; the flow vectors at the control points are represented in terms of a hull-surface coordinate system which requires only two components to determine the flow vector, and a smooth interpolation of

the flow vectors is found using B-spline basis functions. The resulting representation of the flow is much more convenient to use in subsequent calculations, and yields a value for the potential flow vector at any point on the hull.

The calculation of the discrete cartesian representation of the potential flow may itself be broken into several steps each of which is done by a single program in the suite of programs called EN967.

- 1) The hull is first approximated by a large number (usually about 1000) of planar quadrilateral panels. The program EN967S takes hull data in the form of B-spline coefficients generated by program SMHULL¹ and calculates corner points and the control points (near the centroids) of the panels.
- 2) Each panel is considered to be covered by a uniform Rankine source distribution of unit strength. Each panel thus causes an incompressible potential flow which vanishes at infinity. Each panel also causes a flux of fluid through each other panel. The program EN967C calculates a matrix of "influence coefficients" a_{ij} which give the flux through panel i due to the source distribution on panel j .
- 3) Each panel is assigned an undetermined source strength, σ_i . The solution to the potential flow problem can then be reduced to the solution of a linear system of equations to determine values for the source strengths such that the no-flux boundary condition is satisfied. The solution of the linear system is performed in EN967D.
- 4) When the panel source strengths are known, the velocity at any point in the fluid may be determined. In EN967E the velocity (in cartesian coordinates) is determined at the control point of each panel.

A user's guide for EN967 is contained in Appendix A. The EN967 suite of programs contains additional programs (EN967A, EN967B, etc.) which are used when calculating potential flows around more complex geometries; only those programs which are needed for the ship hull problem are discussed in this memorandum.

The velocity vectors calculated in EN967E are splined in hull surface coordinates by program VELSP, a user's guide for which is contained in Appendix B.

It will be noted in Figure 1 that the present implementation of the boundary layer calculation consists of a single pass through the programs. This is, in some respects, a 'first order' calculation since the effect of the boundary layer on the potential flow velocities is not accounted for. Further developments will incorporate boundary layer corrections in an iterative scheme and will also require extension of the present thin (with respect to the principal radii of curvature of the surface) boundary layer model to thick attached boundary layers and possibly separated flow in the region of the stern.

2 HULL REPRESENTATION AND COORDINATE SYSTEM

Different cartesian coordinate systems are used for the hull representation in program SMHULL¹ and in the EN967 programs. In addition, a non-orthogonal hull surface coordinate system is used by SMHULL and by program VELSPL when splining the calculated velocities.

SMHULL generates a functional relationship between the cartesian hull coordinate system (X,Y,Z) and the non-orthogonal surface coordinate system (x,s). These two coordinate systems are shown in Figure 2. The cartesian system consists of X directed aft, Y to starboard and Z upwards, with the origin on the keel-line at the FP. The surface coordinate system consists of x, station number, from 0 at the FP to 20 at the AP, and s, non-dimensionalized arclength around the girth, from 0.0 at the deck or waterline to 1.0 at the keel.

X is simply given by

$$X(x) = \frac{x \text{ LBP}}{20} \quad (2.1)$$

and the other cartesian coordinates are related to the surface coordinates by

$$Y(x,s) = \sum_{p=1}^{N_x} \sum_{q=1}^{N_s} \alpha_{pq} B_{p,k_x}(x) B_{q,k_s}(s) \quad , \quad (2.2)$$

$$Z(x,s) = \sum_{p=1}^{N_x} \sum_{q=1}^{N_s} \beta_{pq} B_{p,k_x}(x) B_{q,k_s}(s) \quad , \quad (2.3)$$

where $B_{p,k}$ is the p^{th} B-spline of order k and α_{pq} and β_{pq} are the B-spline coefficients for Y and Z respectively. Details of this procedure are given by Hally¹ and the theory and application of B-splines are discussed by de Boor³ and by Hally⁴.

It is important to note that EN967S assumes that the hull has been defined only so far as the waterplane and will take the waterplane to be the maximum value of Z at each section. Thus, hull data which has been taken further, to the deck for example, must be truncated at the waterplane before processing by SMHULL.

EN967 uses the cartesian coordinate system (x',y',z') shown in Figure 3. x' is directed aft, y' downwards and z' to starboard with the origin at the FP on the waterplane. Furthermore, as shown in the figure, two planes of symmetry are present: the centerplane, because of bilateral hull symmetry, and the waterplane, in accordance with the zero Froude number assumption. With this symmetry, only the quadrant in which y' and z' are both positive is considered directly in the potential flow calculations, the other three quadrants being accounted for as 'images' in the symmetry planes.

3 CALCULATION OF THE DISCRETE CARTESIAN POTENTIAL FLOW

The calculation of the incompressible potential flow velocities for flow around a ship hull consists of solving Laplace's equation subject to given boundary conditions. It has long been known that this can be done efficiently using boundary integral methods, effectively reducing the three-dimensional problem to a two-dimensional one. In order to evaluate the integrals over arbitrary boundaries, recourse had to be made to discretisation, which led to the historical development of panel methods exemplified by the early work of Hess and Smith⁵.

The method used in present work is essentially as formulated by Hess and Smith⁵. For a rigorous development of the theory, the reader is referred to the article by Hunt⁶ on boundary integral methods. The principal steps are outlined below.

Figure 4 represents a three-dimensional domain Ω with boundary S on which the normal n is directed into Ω . P is any point in the domain, or flow region. The unknown velocity potential in the domain, Φ , satisfies Laplace's equation in this region:

$$\nabla^2 \Phi = 0 \quad \text{in } \Omega \quad (3.1)$$

It is convenient to split Φ into two terms:

$$\Phi = \Phi_S + \Phi_\infty \quad (3.2)$$

Φ_S is an inner solution which induces velocities which vanish at infinity. Since the flow has no circulation and there is no free surface, an appropriate form for Φ_S is that derived from a simple (Rankine) source⁷ distribution on the inner boundaries; the boundary condition that the the velocities induced by Φ_S vanish at infinity is then automatically satisfied.

$$\Phi_S = -\frac{1}{4\pi T} \int_S \sigma \frac{r}{r^2} dS \quad (3.3)$$

$4\pi T$ is the solid angle subtended by the boundary at the point at which the potential is evaluated. If this point is within the domain Ω , the solid angle will be 4π ; if the point is on S , the solid angle will be less than 4π .

Φ_∞ accounts for the boundary condition that the velocity be uniform at infinity:

$$\Phi_\infty = -\mathbf{x} \cdot \mathbf{V}_\infty \quad (3.4)$$

where \mathbf{V}_∞ is the free stream velocity. Notice that both Φ_S and Φ_∞ satisfy Laplace's equation separately. The boundary condition satisfied at S is

$$n \cdot \nabla \Phi = 0 \quad (3.5)$$

which may be expressed as

$$\mathbf{n} \cdot \nabla \Phi_S = \mathbf{n} \cdot \mathbf{V}_\infty \text{ on } S \quad (3.6)$$

The problem has now been reduced to determining the unknown source density σ such that the boundary condition of equation (3.6) is satisfied. Since the surface integral in equation (3.3) can only be evaluated analytically for certain regular shapes, in general the problem must be discretized and the surface integral replaced by a summation as illustrated by Figure 5. The surface is discretized into a number of panels each with an associated control point at which the boundary condition is enforced. The source distribution is uniform over the extent of each panel. The inner potential Φ_S may then be expressed as

$$\Phi_S = \sum_j \sigma_j \Phi_{Sj} \quad (3.7)$$

where

$$\Phi_{Sj} = -\frac{1}{4\pi T} \int_{S_j} \frac{r}{r^2} dS \quad (3.8)$$

where Φ_{Sj} is the contribution to the potential from a unit source distribution on the j^{th} panel. The velocity at the i^{th} control point \mathbf{x}_i in the domain is

$$\mathbf{V}_i = \sum_j \mathbf{a}_{ij} \sigma_j \quad (3.9)$$

where

$$\mathbf{a}_{ij} = -\nabla \Phi_{Sj}(\mathbf{x}_i). \quad (3.10)$$

\mathbf{a}_{ij} is the velocity induced at the i^{th} control point due to a unit source distribution on the j^{th} panel. They are called the influence coefficients.

The boundary condition of equation (3.6) evaluated at the i^{th} control point is

$$\mathbf{n}_i \cdot \mathbf{V}_\infty = \sum_j \mathbf{n}_i \cdot \mathbf{a}_{ij} \sigma_j \quad (3.11)$$

The σ_j 's are evaluated by inverting equation (3.11). The tangential velocity components and velocities in the field are then obtained directly from equation (3.9). Pressures may be calculated with Bernoulli's equation⁷.

In the discrete model, each influence coefficient contains the surface integral of

equation (3.3) evaluated over the j^{th} panel only. For the present work, the panel is assumed to be planar, and the source distribution to be constant on its surface. This is the first-order approximation and results in relatively simple analytic expressions for the surface integral.

4 COMPRESSIBILITY CORRECTION FOR POTENTIAL FLOW

Where the calculation is being done for comparison with data from a model in a wind tunnel, compressibility of the fluid must be taken into account when the local Mach number becomes too large. A rule of thumb is that corrections should be made when the free-stream Mach number, M_∞ , exceeds 0.3. Such compressible flows are governed by the Prandtl-Glauert equation,

$$(1 - M_\infty^2) \frac{\partial^2 \Phi}{\partial x'^2} + \frac{\partial^2 \Phi}{\partial y'^2} + \frac{\partial^2 \Phi}{\partial z'^2} = 0 \quad (4.1)$$

so long as the local Mach number does not exceed 1.0. The Prandtl-Glauert equation can be reduced to Laplace's equation by the application of Gothert's rule⁸, a coordinate transformation which stretches the hull in the x' direction. The calculated incompressible velocity potential is then transformed back to compressible coordinates.

5 SPLINING THE DISCRETE CARTESIAN POTENTIAL FLOW

In this section the technique used by the program VELSPL to spline the discrete cartesian potential flow will be described.

5.1 REPRESENTATION OF THE VELOCITY VECTOR IN HULL COORDINATES

Since the hull coordinates are, in general, non-orthogonal, there are several ways in which the flow vectors can be represented in these coordinates. The most convenient is to provide the covariant or the contravariant components of the vector. Although the covariant components of the vectors are the most straightforward to calculate the representation in terms of contravariant components has been chosen for two reasons.

- 1) It is required that the keel and the waterline are streamlines. These conditions are most easily enforced using the contravariant representation (see Section 5.3).
- 2) The calculation of streamlines is simplified by the use of the contravariant representation (see Appendix C).

The contravariant components of a vector in the non-orthogonal surface coordinate system can be determined if the relationship between these coordinates and the cartesian coordinate system is known. The calculation method is outlined below. Define two linearly independent hull-surface vectors, \mathbf{e}_k , $k = 1, 2$, by

$$\mathbf{e}_n = \frac{\partial X}{\partial x_n} \quad (5.1)$$

where, for convenience, the position coordinate (x,s) has been denoted (x_1, x_2) . Two additional linearly independent hull-surface vectors, \mathbf{e}^k , may then be defined such that

$$\mathbf{e}^k \cdot \mathbf{e}_n = \delta_n^k \quad (5.2)$$

where δ_n^k is the Kronecker delta. Simple algebraic manipulation then gives

$$(\mathbf{e}_n \cdot \mathbf{e}_k) \mathbf{e}^k = \mathbf{e}_n \quad (5.3)$$

where summation over repeated indices is implicit. The \mathbf{e}^k may therefore be obtained from the \mathbf{e}_k by the inversion of the 2×2 matrix $\mathbf{e}_n \cdot \mathbf{e}_k$. The contravariant components, v^k of a vector, \mathbf{V} , are defined by

$$v^k = \mathbf{V} \cdot \mathbf{e}^k \quad (5.4)$$

Since the derivatives $\partial X / \partial x$ may be calculated easily using the spline coefficients supplied by SMHULL¹ the calculation of the contravariant components at the control points is straightforward.

5.2 SPLINING THE CONTRAVARIANT VELOCITY COMPONENTS

Once the contravariant components of the velocity vectors are known at the control point, these values are interpolated using a smoothing spline. The resulting two dimensional spline may be used to determine the value of the contravariant velocity components at any point on the hull. The method of splining is very similar to that used for splining the cartesian coordinates in the program SMHULL¹, and so will be treated in less detail here.

The use of smoothing spline rather than splines which interpolate the data is prompted by two observations: that splines can be very sensitive to the placement of the data points and the overall spline fit can often be improved dramatically by allowing the spline to vary very slightly from the data points; and that the velocities calculated by EN967 cannot be considered without error, so that improvements of the splines within the tolerances of the errors expected from EN967 can only improve resulting calculations. It should also be emphasized that the user has control over the amount of smoothing done by the spline (see Appendix B.4.1).

5.2.1 REPRESENTATION OF THE VELOCITY IN TERMS OF B-SPLINES

The contravariant components of the velocity V^1 and V^2 are represented as two-dimensional splines in terms of the independent variables x and s . The control points must form a rectangular grid in the non-orthogonal coordinates, (x,s) ; that is, the control points must be of the form $\{(x_p, s_q): p=1, N_x; q=1, N_y\}$. This is ensured by the program EN967S when it chooses the control points.

$$V^k(x,s) = \sum_{p=1}^{N_x} \sum_{q=1}^{N_s} \lambda_{p,q}^k B_{p,k_x}(x) B_{q,k_s}(s) \quad (5.5)$$

where $B_{p,k_x}(x)$, $p=1, N_x$, is a B-spline of order k_x corresponding to a knot sequence $t_p^{(x)}$, $p=1, N_x+k_x$, and similarly for $B_{q,k_s}(s)$. Notice that the orders of the B-splines in the x and s directions need not be the same, nor need these be the same as the orders of the knot sequences used in the SMHULL spline representation, despite the similarity in notation used here and in Section 2.

For the purposes of computation, it is most convenient to express equation (5.5) in the following form:

$$V^k(x,s) = \sum_{q=1}^{N_s} \mu_q^k(x) B_{q,k_s}(s), \quad (5.6)$$

$$\mu_q^k(x) = \sum_{p=1}^{N_x} \lambda_{pq}^k B_{p,k_x}(x). \quad (5.7)$$

5.2.2 EVALUATION OF THE SPLINE COEFFICIENTS

The evaluation of the spline coefficients λ_{pq}^k can be broken into two steps:

- 1) On each curve of constant x , the contravariant velocity components are splined in the s direction using the knots $t_q^{(s)}$, $q=1, N_s+k_s$. This yields the spline coefficients $\mu_q^k(x_p)$, where x_p is the p -th curve of constant x .
- 2) The spline coefficients $\mu_q^k(x_p)$ are themselves splined in the x direction using the knots $t_p^{(x)}$, $p=1, N_x+k_x$. This yields the required spline coefficients λ_{pq}^k . For this step to be possible it is necessary that the same number of B-splines be used to spline each offset station and that the knots vary smoothly as functions of x . Here, the same knots are taken for every offset station, reducing the necessary storage space.

The knots for the B-splines may be input directly by the user or default values may be accepted (see Appendix).

Techniques for constructing smooth spline curves approximating given data have been described in detail by de Boor³ and by Hally^{1,4}. The subroutine BSMTH described by Hally⁴ has been chosen for use in VELSP. It determines a smooth, accurate approximation to the given data, with good control over the 'wiggles' which plague other spline methods.

5.3 END POINT CONDITIONS FOR THE SPLINES

The velocities calculated by EN967 are given at the control points of the planar panels. Since the control points are near the centres of the panels, there are no velocities given at the boundaries of the the hull, keel and the waterline. However, the symmetry of the hull requires that the keel and the waterline be streamlines, so the splines of the velocity data must take this into account. Since the keel and the waterline are curves of constant hull coordinate s , the end point condition applied to the splines may be restated as follows. Since e_1 is a vector parallel to the curve of constant s , e^2 is a vector perpendicular to the curve of constant s (see equation 5.2). Hence, the condition that a curve of constant s be a streamline is

$$V \cdot e^2 = V^2 = 0 \quad (5.8)$$

Hence, the streamline condition to be applied to the splines reduces to a constraint on the value of V^2 at the boundary. This constraint is implemented most easily by requiring that the first k_s knots in the s -direction, $t_p^{(s)}$, $p=1, k_s$ lie at $s = 0$ (the waterline) and that the last k_s knots $t_p^{(s)}$, $p=N_s+1, N_s+k_s$, lie at $s = 1$ (the keel). One can then show³ that

$$\mu^k_1(x) = V^2(x,0) ; \mu^k_{N_s}(x) = V^2(x,1). \quad (5.9)$$

Thus, the waterline and keel can be constrained to be streamlines simply by requiring that $\lambda^2_{1q} = 0$ and that $\lambda^2_{N_s q} = 0$.

6 CONCLUDING REMARKS

Incompressible potential flow gives an adequate description of the flow around a ship hull for many purposes including the computation of surface velocities for a boundary layer calculation. Details of a numerical method for calculating this flow have been presented together with a method for interpolating the output data to make it more suitable for use in further hydrodynamic computations.

The appendices to this memorandum provide user guides to computer programs which calculate potential flow and which spline the resulting surface velocities. These programs form part of a total package for calculating the development of ship hull boundary layers, the other parts of which are documented by Hally^{1,2}.

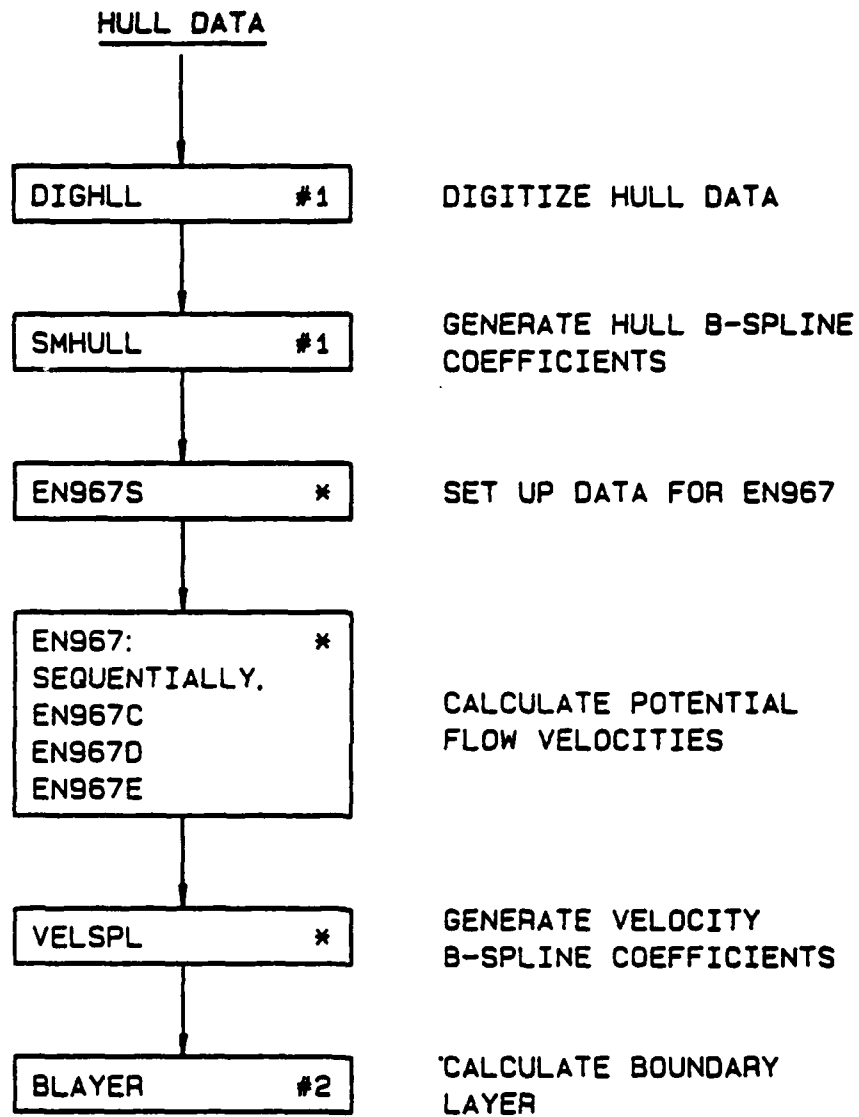

#1: DESCRIBED IN REFERENCE 1
 *: DESCRIBED IN THIS MEMORANDUM
 #2: DESCRIBED IN REFERENCE 2

Figure 1. Flow Chart of Boundary Layer Calculation

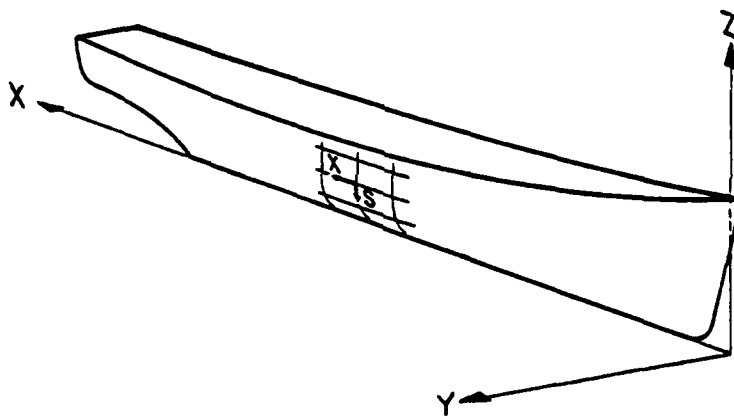

Figure 2. SMHULL Coordinate Systems

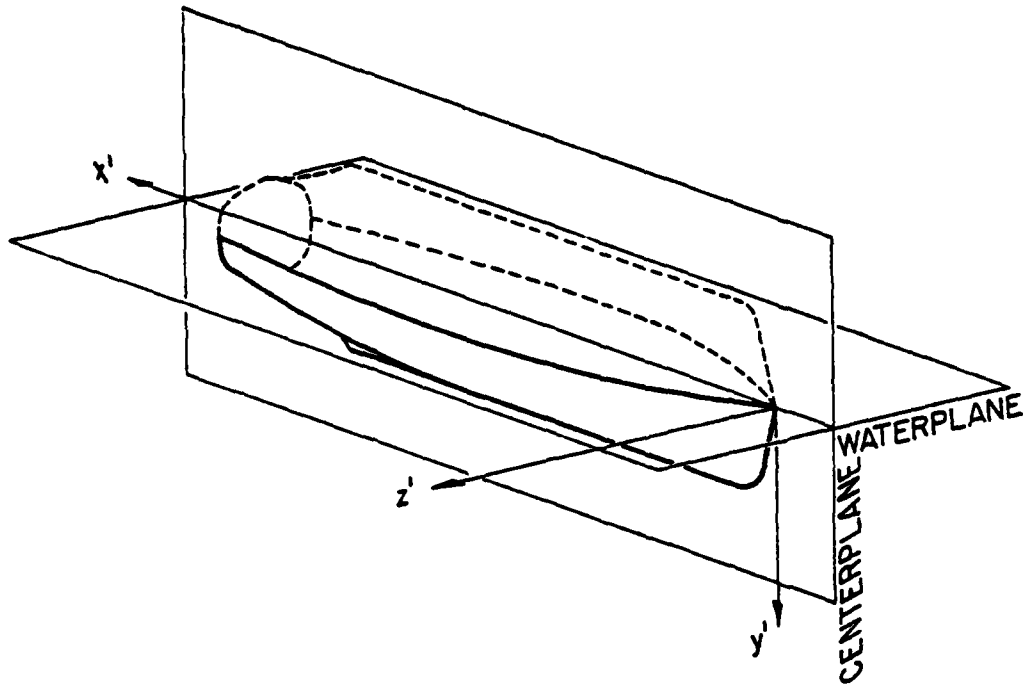

Figure 3. EN967 Coordinate System

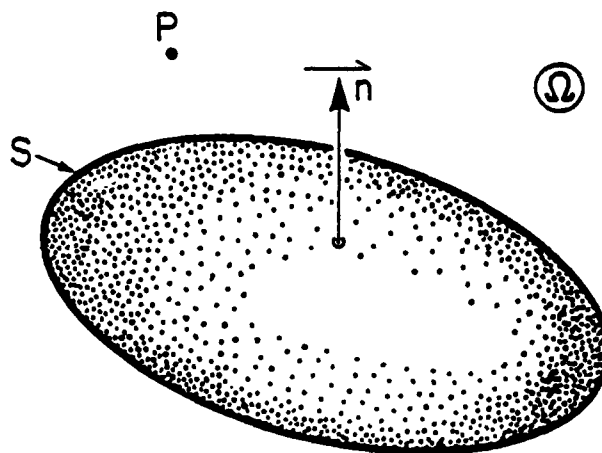

Figure 4. Schematic representation of a Flow Region, Ω

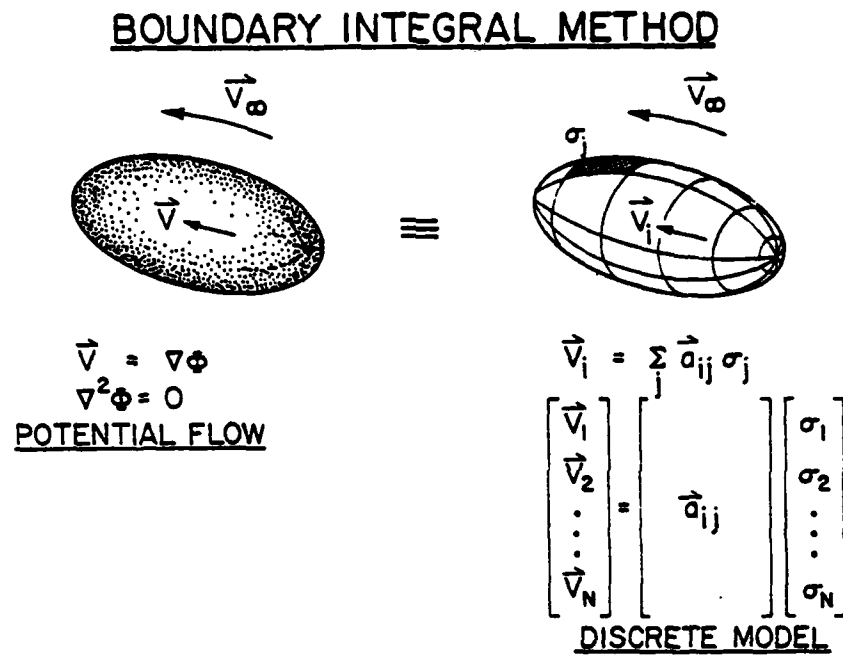

Figure 5. Equivalence of Potential Flow and Discrete Model

Appendix A

USER'S GUIDES FOR THE EN967 PROGRAMS

The program suite EN967 was obtained from the DeHavilland Aircraft Company of Canada Ltd. It models lifting surfaces and therefore includes line vortex singularities in addition to sources. The original 'front end' was optimized for the representation of aircraft geometries and consisted of two programs:

EN967A - sets up total geometry from an input description of cross-sections etc., in terms of non-planar panels (ie.: panels whose corner points lie on the true surface).

EN967B - calculates equivalent planar panels from which influence coefficients can be calculated. Locates control points.

For lifting surfaces, EN967A and EN967B also perform analogous functions for the vortices.

For ship hulls the above two programs are replaced by a single program, EN967S, which takes as input data the hull B-spline coefficients on a data file created by SMHULL¹. EN967S mimics the two programs, producing disc files and lineprinter output in the original format, the latter being labelled EN967A or EN967B equivalent. In addition, EN967S writes the input files EN967C.DAT, EN967D.DAT and EN967E.DAT required to complete the potential flow calculation, so that the remaining steps are virtually transparent to the user.

The EN967 programs save significant intermediate results on binary disc files called NAME*.DAT, where * is an integer between 7 and 30. A list of these files and their functions is given in Table A.1. Note that although no vortices are used in the ship hull calculations, EN967S creates the file NAME7.DAT containing the vortex data nevertheless, so that EN967C will not fail because it can't find the input file. NAME7.DAT is empty if created by EN967S. Similarly, EN967C creates empty files NAME15.DAT and NAME17.DAT for use in EN967D and EN967E respectively.

The NAME* files generate a considerable storage requirement if a large number of hull panels is used. Storage on the DREA DEC 2060 is measured in pages; a page consists of 512 16-bit words. Table A.1 gives the storage requirement for a 1000 panel example. Note that, as a rule of thumb, NAME* file storage is proportional to the square of the number of panels.

A.1 USER'S GUIDE FOR EN967S

Program EN967S generates the non-planar and equivalent planar panel geometry from B-spline coefficients supplied by program SMHULL. The program initially distributes non-planar panels so that their corner points are equally spaced in (x,s) coordinates. The number of panels in each direction is requested by the user. The user may then modify

the panel distribution so that it is more optimal for the potential flow calculation: the lengthwise (x) distribution is altered so that regions with great curvature have a higher panel density than regions with a lesser curvature. This is achieved by making panel lengths inversely proportional to the second x -derivative of the arclength in the s direction. Adjacent panel lengths are constrained so that their ratio does not exceed 1.5. This modified panel distribution will have more panels in the x direction than were initially requested.

Figure A.1 illustrates the principal geometrical features of a non-planar panel (with curvatures greatly exaggerated) and the equivalent planar panel. The non-planar panel corner points, P_i , $i=1,4$, and the panel control point, P_{CP} , are determined from the spline coefficients supplied by SMHULL, as are the gradients of the surface coordinates with respect to the cartesian coordinates, x and s . The panel normal, n , is directed along the vector product of these gradients. The equivalent planar panel is located by point P_N on the normal, where P_N is the average of the control point and the non-planar corner points. Corner points of the planar panel, P'_i , $i=1,4$, are projections of the non-planar panel corner points.

The panel control point must be within the flow domain, or on its boundaries. For a concave non-planar panel the locations of P_{CP} and P_N are reversed from the configuration shown in Figure A.1, placing the control point outside the domain. In this case, P_N is co-located with P_{CP} .

EN967S calculates a number of additional properties of the planar panel: side lengths and slopes, and zeroth (area), first and second moments of inertia. These are required to determine the influence coefficients in EN967C.

A.1.1 OPERATION OF EN967S

To run EN967S on the DREA DEC-20 computer

```
EXECUTE PS:<MACKAY>EN967S, PS:<HALLY>SMSUBS/LIB, PS:<HALLY>GETWRD/LIB,
BSPLIN:HLLYSP/LIB, BSPLIN:BSPLN7/LIB
```

Program SMHULL supplies an ASCII free-format file (except for record 1) which is read by EN967S. The contents of the file are outlined in Table A.2. In addition, there is a small amount of dialog with the user at execution time: this is described below. Items labelled 'prompt' and 'comment' are generated by the program; items labelled 'response' are entered by the user.

Prompt 1: ENTER P FOR LPT: OUTPUT - OTHERWISE ON EN967S.OUT

Response: The character 'P' or 'p' directs the program output tables to the printer. Any other response (including <CR>) causes the output to be saved on file EN967S.OUT.

Prompt 2: Enter name of file containing hull spline coefficients =>

Response: FILDUM: the name (extension optional, the default is .DAT) of the SMHULL data file. A caret (^) aborts the run.

Comment: Reading data from FILDUM ... Done
...HULL DATA FILE TITLE IS :
TYTLE (up to 60 characters)

Prompt 3: ENTER NO. OF PANELS IN X DIRECTION ...
... IE: NO. OF SECTIONS BOW TO STERN (MAX 49)

Response: NXC: a positive integer, less than or equal to limit NXCM (currently 49).

Prompt 4: ENTER NO. OF PANELS AROUND GIRTH (MAX 49)

Response: NSC: a positive integer, less than or equal to limit NSCM (currently 49).

Prompt 5: ENTER G TO USE VARIABLE GRID OPTION

Response: The character 'G' or 'g' results in a grid adjustment as described in the general discussion of the program. The number of panels in the x-direction will be increased. Any other response (including <CR>) will cause this option to be ignored.

Comment: NO. OF X-PANELS IS NXC (where NXC is revised as above)

Prompt 6: ENTER T FOR GOTHERT TRANSFORMATION

Response: The character 'T' or 't' indicates that compressibility corrections will be required and Prompt 7 will be given. Any other response (including <CR>) will result in the Mach number being set to zero.

Prompt 7: ... MACH NUMBER ?

Response: AMACH: freestream Mach number.

In general, an unacceptable response will result in a self-explanatory error message and a repeat of the appropriate prompt. Note in particular that there is a limit on the number of panels which can be accommodated by EN967. This limit is 1200 in the standard version of the program. If the limit is exceeded, either by choice of NXC and NSC, or inadvertently when using the grid adjustment option, an error message is given and the program returns to Prompt 3.

Execution of EN967S is quite fast: 25 seconds of CPU time for 1000 panels (25x40) without grid adjustment, and 35 seconds with grid adjustment (17x40 → 25x40). CPU time is approximately proportional to the number of panels.

A.1.2 OUTPUT FROM EN967S

EN967S produces tables of results and disc files for the use of subsequent program units. The tables are either printed immediately or stored on a file EN967S.OUT, according to the response to Prompt 1 in the previous section. Disc file output consists

of ASCII formatted files EN967C/D/E.DAT and the binary files NAME7/9/12/17/18/24.DAT.

The results tables from EN967S include

- date and time of run
- title, with date and time appended; this version of the title is passed on to subsequent EN967 units and provides a unique run identifier
- NXC, NSC: numbers of panels in x and s direction
- length, half-breadth and depth of hull
- x', y', z' coordinates of P_1, P_2, P_3, P_4 , the non-planar panel corner points ("EN967A equivalent output")
- x', y', z' elements of the vectors T_1 and T_2 defining the planar panel and the normal vector n , and x', y', z' coordinates of the control point P_{CP} and the planar panel definition point P_N (refer to Figure A.1 for definitions). Vectors T_1 and T_2 join the corners of the planar panel and are normal to n ("EN967B equivalent output").

The content and format of output files EN967C/D/E.DAT are described in the input sections of the appropriate program. The purpose of files NAME7/9/12/17/18/24.DAT is summarized in Table A.1.

The user who does not wish to be concerned with the details of programs EN967C/D/E may proceed directly to Section A.5 for the commands to run these units.

A.2 USER'S GUIDE FOR EN967C

Program EN967C calculates the elements a_{ij} of the influence coefficient matrix. It remains essentially as coded at DeHavilland, except that the self-influence calculation is modified so that the control point need not lie on the planar panel.

The influence of a planar source panel is calculated with the formulae given by Hess and Smith⁵; these formulae will not be repeated here. A characteristic dimension of the panel, the longest diagonal, is chosen, and the ratio of the distance to the panel and the characteristic dimension is determined. For computational efficiency, the influence coefficient is then given by

- far-influence, if the ratio is greater than 6. A point source approximation is used.
- mid-influence, if the ratio is between 2.45 and 6. A multipole expansion of the source density is used.

- near-influence, if the ratio is less than 2.45. The surface integral over the planar panel is evaluated exactly.

To avoid numerical difficulties with self-influence when P_{CP} and P_N are not co-located, the near-influence formula for the normal component is modified by an expansion with respect to the distance of P_{CP} above the panel. If P_{CP} and P_N are co-located, the normal evaluation of self-influence is used.

As only one quadrant (both y' and z' positive) of the double hull geometry is explicitly accounted for (Figure 3), each influence coefficient represents the sum of terms from all four quadrants.

A.2.1 OPERATION OF EN967C

To run EN967C on the DREA DEC-20 computer:

```
EXECUTE PS: <MACKAY>EN967C
```

EN967C requires an ASCII formatted data file EN967C.DAT, and binary files NAME7/9/24.DAT, created in EN967S. The contents of EN967C.DAT are outlined in Table A.3. The default values shown are supplied by EN967S.

A case with 1000 panels and two planes of symmetry takes about 34 CPU minutes; execution time is approximately proportional to the number of panels squared.

A.2.2 OUTPUT FROM EN967C

EN967C prints one page of output:

- date and time of run
- KODE, KXOUT (see Table A.3)
- title
- counters which indicate how many times each method for calculating source influence is used: KEX for self- and near-influence, KMP for mid-influence and KPS for far-influence. The total of these is four times the square of the number of panels for two planes of symmetry
- message: "PART C COMPLETED"

In addition, if KXOUT = 1, the matrix of influence coefficients is printed in 1PE12.4 format. The function of binary disc files NAME10/11/13/15.DAT generated by EN967C is summarized in Table A.1.

A.3 USER'S GUIDE FOR EN967D

Program EN967D solves the set of simultaneous equations represented by equation (3.9). It remains essentially as coded at DeHavilland.

The iterative method described by Labrujere et al.⁹ is used. The influence matrix is 'blocked', or subdivided. Since matrix entries near the diagonal are dominant due to large self- and near-influence terms, solving the submatrices on the diagonal alone gives a fair approximation to the inverse of the full matrix. A correction term is formulated and the calculation is iterated until the deviation from the required tangential flow boundary condition (the residual) is acceptable. Less than 10 iterations is usually sufficient for convergence. The calculation is terminated after 30 iterations if convergence has not occurred; this condition usually indicates that mixed NAME*.DAT files from different runs are being used since the influence matrix is invariably well conditioned for ship hulls. A Gauss-Seidel algorithm is used to invert the submatrices.

A.3.1 OPERATION OF EN967D

To run EN967D on the DREA DEC-20 computer

```
EXECUTE PS: <MACKAY>EN967D
```

EN967D requires an ASCII formatted data file EN967D.DAT, and binary files NAME10/15.DAT, created in EN967C. The contents of EN967D.DAT are outlined in Table A.4. The defaults are set by EN967S.

A case with 1000 panels takes about 4.5 CPU minutes; execution time is approximately proportional to the number of panels.

A.3.2 OUTPUT FROM EN967D

EN967D produces the following lineprinter output according to the default value of NSB (see Table A.4):

- matrix blocking information
- a number of items not relevant to use with EN967S, including vortex, angle of attack and submatrix inversion data (these can be significant for lifting surface applications)
- sum of squares of residuals for each submatrix

The angles of attack (alpha) and sideslip (beta) referred to in this, and EN967E, output are constrained to be zero with EN967S since the freestream flow must be tangential to both planes of symmetry (Figure 3).

If NSB is given the alternative value noted in Table A.4, a detailed table is printed including source densities and residuals for the last iteration.

The function of binary disc file NAME16.DAT generated in EN967D is summarized in Table A.1.

A.4 USER'S GUIDE FOR EN967E

Program EN967E calculates surface velocities using equation (3.9). Primarily of interest in aerodynamic applications rather than the task addressed here, are a number of derived quantities:

- pressure coefficients,
- force and moment coefficients

The potential flow about a symmetrical nonlifting body gives, within numerical error, zero total forces and moments.

A.4.1 OPERATION OF EN967E

To run EN967E on the DREA DEC-20 computer

```
EXECUTE PS: <MACKAY>EN967E
```

EN967E requires an ASCII formatted data file EN967E.DAT, and binary files NAME11/12/13/16/24.DAT, created in EN967S/C/D. The contents of EN967E.DAT are outlined in Table A.5. The defaults are set by EN967S.

A case with 1000 panels and two planes of symmetry takes about 9.5 CPU minutes; execution time is approximately proportional to the square of the number of panels.

If the default IILPT (see Table A.5) has been accepted and tabular output is required,

```
PRINT EEOUT/FILE:FORTTRAN
```

A.4.2 OUTPUT FROM EN967E

EN967E saves on EEOUT.DAT, or prints, the following lineprinter output according to the default value of IILPT:

- run date and time
- title and Mach number
- for each control point: x',y',z' coordinates, x',y',z' components of flow velocity, source density and pressure coefficient
- force and moment coefficients by block ('section') and totals

If EEOUT.DAT is saved, a single page of lineprinter output is generated indicating completion and reminding the user to print EEOUT.DAT (if required).

EN967E saves velocities and pressure coefficients on NAME30.DAT for the use of VELSP, by default.

A.5 SUMMARY OF OPERATING PROCEDURE FOR EN967C/D/E

In the preceding sections, programs EN967C, EN967D and EN967E have been outlined. However, since EN967S prepares the necessary input files, the casual user need not bother with these details, but simply invoke, on the DREA DEC-20 system,

```
EXECUTE PS: <MACKAY>EN967C  
EXECUTE PS: <MACKAY>EN967D  
EXECUTE PS: <MACKAY>EN967E  
PRINT EEDOUT/FILE:FORTAN
```

Note however, that user directories will generally be too small to accommodate the NAME*.DAT files, so that these units will have to be run on DREA:<DREA>. The NAME*.DAT files will remain in the host directory until deleted.

Disc storage requirements are summarized in Table A.1 and execution times in Figure A.2.

Table A.1

TEMPORARY DISC FILE STORAGE FOR EN967

FILENAME	CREATED IN	USED IN	CONTAINS	STORAGE IN PAGES, FOR 1000 PANELS
NAME7.DAT	EN967S	EN967C	vortex data	0
NAME9.DAT	EN967S	EN967C	planar panel data	79
NAME10.DAT	EN967C	EN967D	normal induced velocities	1975
NAME11.DAT	EN967C	EN967E	source influence matrix	5917
NAME12.DAT	EN967S	EN967E	control point data	18
NAME13.DAT	EN967C	EN967E	normal vortex induced velocities	0
NAME15.DAT	EN967C	EN967D	vortex influence matrix	0
NAME16.DAT	EN967D	EN967E	singularity strengths	2
NAME17.DAT	EN967S	VELSPL	surface derivatives	8
NAME18.DAT	EN967S		non-planar panel data	28
NAME24.DAT	EN967S	EN967C/E	geometry counters	3
NAME30.DAT	EN967E	VELSPL	velocities and pressure coefs.	18

NOTES

- 1) Files associated with vortex data are empty (NAME7/13/15).
- 2) The storage for NAME10 and NAME11 is proportional to the square of the number of panels; for other files it is proportional to the number of panels.
- 3) NAME18 is included to make EN967S output equivalent to that of EN967A; the file is not used for boundary layer calculations. New graphics software is being planned which will use this file.

Table A.2

CONTENTS OF EN967S INPUT DATA FILE

Record	Variable	Format	Purpose
1	TYTLE UNITS	A60 A4	60 character title units used
2	SLNGTH BREDTH DEPTH	free free free	LBP maximum half-breadth maximum draft
3	NST XS (IX)	free free	number of stations station numbers, IX=1,NST
4	KS NS TS (I)	free free free	order of B-splines in s-direction number of B-splines in s-direction s-knot locations, I=1,KS+NS
5	KX NX TX (I)	free free free	order of B-splines in x-direction number of B-splines in x-direction x-knot locations, I=1,KX+NX
6	BCOEFY (IS, IX), BCOEFZ (IS, IX)	free	B-spline coefficients α_{ij} and β_{ij} IS=1,NS; IX=1,NX

Table A.3

CONTENTS OF EN967C.DAT

Record	Variable	Format	Default	Purpose
1	KODE	I2	0	use default; other values not relevant with EN967S
	KXOUT	2X, I2	0	= 1, print influence matrix = 0, otherwise

Table A.4

CONTENTS OF EN967D.DAT

Record	Variable	Format	Default	Purpose
1	M	I4	*	number of blocks
	NH(I), I=1,M	19I4/20I4	*	number of control points in i^{th} block
2	NSB	I4	8888	= 0, full output for last iteration = 8888, minimum output

NOTES

- * The defaults are NH(I) = NSC and M = NXC if NSC is greater than 20. Otherwise, NH(I) = 2*NSC and M is adjusted accordingly (NH(M) = NSC if M is odd).

Table A.5

CONTENTS OF EN967E.DAT

Record	Variable	Format	Default	Purpose
1	IIBIN	2X,I2	0	= 0, file NAME30.DAT is saved (see Table A.1) otherwise not
	IILPT	I2	0	= 0, printer output is saved in file EEOUT.DAT, otherwise it is printed immediately
	SW	2X,F8.0	length*breadth	reference area for force and moment coefficients, as are B and C
	B C X,Y,Z	F8.0 F8.0 3F8.0	breadth length 0,0,0	lateral reference length longitudinal reference length moment reference point
2	N	4X,I2	0	use default; other values not relevant with EN967S
3	KDSUBI	4X,I2	0	use default; other values not relevant with EN967S

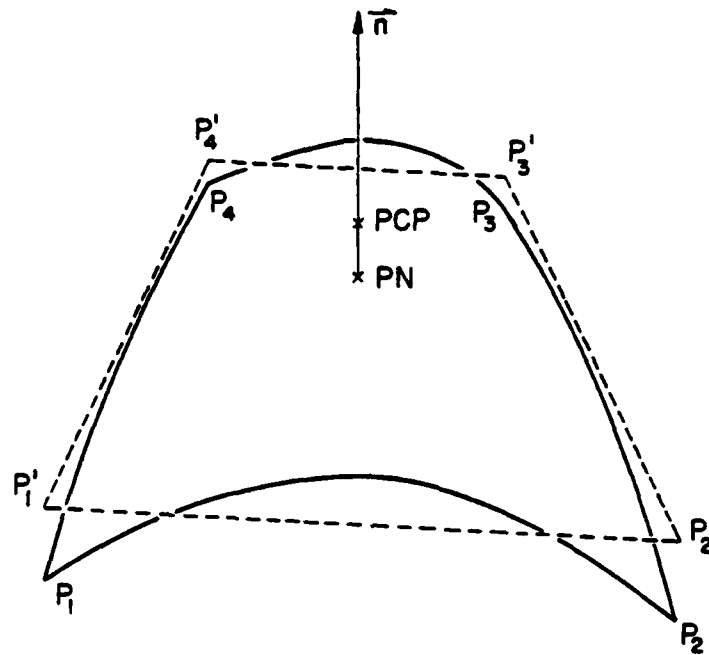

Figure A.1. Panel Geometry

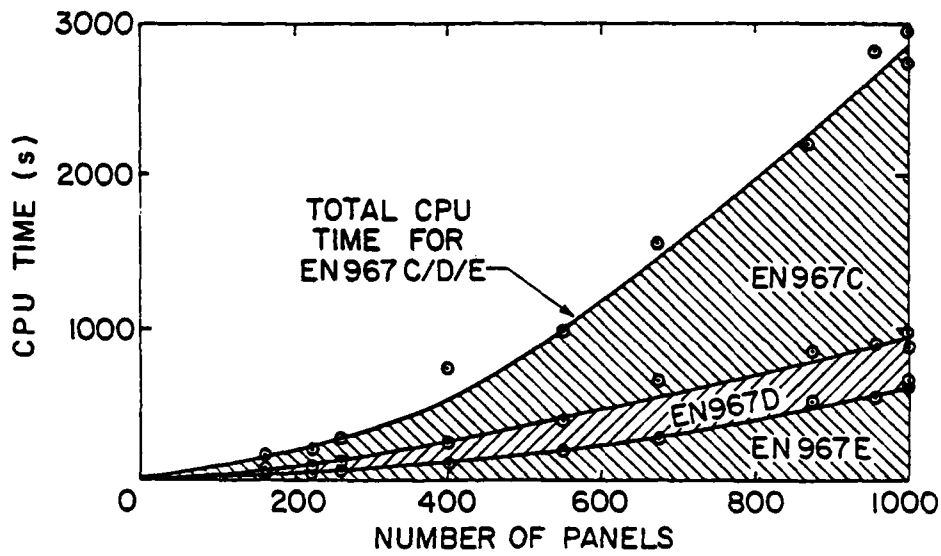

Figure A.2. CPU Times for EN967C/D/E: DREA DEC-20 Computer

Appendix B

USER'S GUIDE FOR VELSPL

VELSPL calculates a smooth parametric B-spline approximation to the discrete cartesian flow vectors provided by EN967. It has been designed to be used in conjunction with the hull splining program SMHULL¹, the suite of programs EN967, and the hull display programs STMHLC and DSPHLL¹⁰. VELSPL is equipped with a wide range of defaults allowing both ease of use for the inexperienced user, and generality for the experienced user with a difficult problem.

VELSPL is written in FORTRAN 7.0 on the DEC-20 at DREA and calls subroutines from the spline libraries BSPLIN:BSPLN7³ and BSPLIN:HLLYSP⁴, from the GETWRD Package¹¹, and from the PLOT10 library¹². At DREA, VELSPL may be obtained by the following calling sequence:

```
EXECUTE PS:<HALLY>VELSPL, PS:<HALLY>SMSUBS/LIB, PS:<HALLY>GETWRD,  
BSPLIN:HLLYSP/LIB, BSPLIN:BSPLN7/LIB, PS:<LIB>PLOT10/LIB
```

VELSPL is designed to be run on a Tektronix graphics terminal or equivalent, although, if none of the plotting features are being used, it is possible to run it on a non-graphics terminal.

VELSPL interacts with the user via a command language described in the next section. The commands and their functions are described in subsequent sections.

B.1 TERMINALS AND PLOTTERS

In this section information about terminals and plotters which can be used with VELSPL is presented.

B.1.1 IDENTIFYING TERMINAL AND PLOTTER TYPE

VELSPL has been designed for use with both a terminal and a plotter, though in the case of PLOT10 compatible terminals these may be one and the same, and if none of the plotting features are used the terminal need not support graphics. The terminal is used for all interaction between user and program via the command language, while the plotter is used for all graphic output. Immediately upon entering any of the programs, the user will be prompted for the type of terminal being used. The list below gives the terminals currently recognized and the commands used to identify them:

- 1) Tektronix 4006: 4006
- 2) Tektronix 4010: 4010
- 3) Tektronix 4012: 4012

- 4) Tektronix 4013: 4013
- 5) Tektronix 4014: 4014
- 6) Tektronix 4015: 4015
- 7) Tektronix 4016: 4016
- 8) Retrographics upgrade of a Digital VT100: VT100/RG

When the terminal type has been identified, the user is prompted to determine what device is being used to generate the graphic displays. This may be the terminal or a plotter. If a plotter is used, the command prompts will appear on the terminal screen but all graphic displays are drawn on the plotter. Allowed responses to the prompt for the type of plotter are

4662, 4662/31, 4663 and TERMINAL

where 4662 and 4663 indicate the Tektronix plotters of those numbers, 4662/31 indicates a Tektronix 4662 plotter with option 31, and TERMINAL indicates that the terminal is being used for all graphic displays. If a plotter is being used, the user will also prompt for the dimensions of the paper on which the plot is to be drawn. These dimensions should be given in inches, the horizontal dimension first followed by the vertical dimension. An optional command which may be entered at the same time as the page dimensions is the extent of the page to be used. There are three possibilities

BOTTOM, FULL or TOP

according to whether the full page is to be used, or the top or bottom half.

Following the prompt for the type of plotter, the user will be prompted for the baud rate currently being used. Note that this does not change the baud rate, it only tells the program what the baud rate is.

A means for changing the type of terminal or plotter at any time during the execution of the program is described in Appendix B.5.7.

B.1.2 SET UP OF 4662 AND 4663 PLOTTERS

When a Tektronix 4662 or 4663 plotter is being used it should be joined in series between the computer and the terminal. The plotter should NOT be in Copy Mode. Appropriate settings for the RS-232-C switches on the rear of the plotter are:

A = 1, B = 2, C = 2, D = 3 for operation at 1200 baud

A = 1, B = 2, C = 2, D = 1 for operation at 300 baud

Make sure the plotter is on before starting the program. It will not work correctly if the plotter is turned on just prior to drawing the graphic display.

Before drawing a graphic display, the user will be prompted to ensure that the

paper is loaded on the plotter. At this time the user should place a clean sheet of paper on the plotter having the dimensions specified by him earlier. The lower left and upper right plotting points should be set at the corresponding points on the paper. The program will leave margins around the display so there is no need to reduce the plotting area to allow for margins. If the plotter has Option 31 there is no need to load a pen: pen #1 will be loaded automatically by the program. If it does not, the user should ensure that a pen is properly loaded before proceeding.

B.2 COMMAND LANGUAGE IN VELSPL

VELSPL interacts with the user via a command language, implemented with the GETWRD package of subroutines¹¹. The GETWRD Package allows a type ahead facility, abbreviated commands, command completion, help messages, and explicit error messages, providing a friendly interface between the user and the program. All the special character defaults in GETWRD have been chosen so that

- a) The *delimiting character* is a blank. All commands must be separated by blanks.
- b) The *help character* is a question mark. For a help message and a list of possible commands, type a question mark.
- c) The *completion character* is a dollar sign. To have the current command completed from an abbreviated form, type a dollar sign.
- d) The *delete letter character* is a back slash, \. To cause the previous letter to be disregarded, type a backslash.
- e) The *delete word character* is an open angle bracket, <. To cause the previous word to be disregarded, type an open angle bracket.
- f) The *abort character* is a caret, ^. To jump back to the highest level of command, type a caret.

At all levels of command the prompt for further input is an arrow, =>. To the left of the arrow appears a short indication of the input desired. At the uppermost level of command the word 'command' is to the left of the arrow. To the right of the arrow appears the text of the command so far. For example, the prompt

```
baud rate=>CHANGE S-ORDER
```

asks the user to input a new value for the order of the splines in the s-direction. The user is at the third level of command, the previous two commands having been CHANGE and S-ORDER. A new user not understanding what is required at this point may type a question mark followed by a carriage return to receive the more explicit help message

Enter the order of the splines in the s-direction.

For further details see the GETWRD Package Manual¹¹.

The command to exit from VELSPL is

command=>EXIT

In addition, VELSP has a sub-command mode in which single character commands are input via the graphic cross-hairs on the terminal screen. The appearance of the cross-hairs is the prompt for the input of a command. Typing a question mark will cause a help message to be written listing the possible commands. The command 'E' will exit to the higher command level. Further details are given below.

B.3 INITIAL INPUT

Upon entering VELSP the message

Entering VELSP ...

is displayed followed by prompts for the terminal type, plotter type, and baud rate as described in Appendix B.1. These are followed by a prompt for the name of the the EN967S output file containing the derivatives of the hull coordinates. This file is called NAME17.DAT by EN967S, but its name might subsequently have been changed by the user. If no extension is given the default extension is .DAT. The default file name, obtained by typing a carriage return only, is NAME17.DAT.

After reading the derivatives of the hull coordinates, the user is prompted for the name of the EN967E output file which contains the cartesian components of the velocity and the pressure coefficients at the panel control points. EN967E calls this file NAME30.DAT, which is the VELSP default name. Errors occurring while reading data from either of these two files will be flagged and program execution terminated.

After reading the velocity components and pressure coefficients, the VELSP prompts for the file in which the spline coefficients are to be stored. The file name can be at most six letters long with a three letter extension: for example, VELSP.DAT. If no extension is given the default extension is .DAT.

VELSP now enters command mode. The prompt

command=>

is given, and the program awaits a command from the user.

B.4 SPLINING WITH DEFAULTS

If none of the defaults are to be changed, splining of the data is begun by giving the command

command=>START

VELSP begins by splining the x-components of the contravariant velocity along each single station followed by the s-components at each station, then it splines the spline coefficients of the x-components, and finally the spline coefficients of the s-components (see Section 5.2). The splines of the stations are numbered by the corresponding station number. The splines of the spline coefficients are numbered sequentially according to

the number of the B-spline coefficient being splined. These numbers are referred to as the numbers of the spline rows.

VELSPL reports on its progress by typing a number on the terminal screen whenever a spline is completed. For the splines of the stations, the number printed is the station number. For the splines of the spline coefficients, the number printed is the number of the spline coefficient. When it is completed, VELSPL writes the spline coefficients in the user-specified output file in the following format:

Record	Variable	Format	Purpose
1	KVS NVS	I3 I3	Order of the splines in the s-direction Number of B-splines in the s-direction
2	TVS(I)	5F15.7	Knots for splines in the s-direction I=1,KVX+NVX
3	KVX NVX	I3 I3	Order of the splines in the s-direction Number of B-splines in the x-direction
4	TVX(I)	5F15.7	Knots for splines in the x-direction I=1,KVX+NVX
5	BCOEFV(IQ,IP,K)	4F15.7	B-spline coefficients λ_{pq}^k IQ=1,NVS; IP=1,NVX; K=1,2

The following message is then written:

Finished splining...

If some of the splines could not achieve the accuracy required of them (i.e. their chi-squares are higher than the input chi-square - see Appendix B.4.1) then the following message will also be written:

Accuracies of splines have been written in VELACC.DAT

In the data file VELACC.DAT, useful information about the accuracies of the splines is written. For each of the splines of insufficient accuracy, the required accuracy of the spline and the actual accuracy of the computed spline are displayed.

The program then returns to command mode. Velocity components for the flow around a different hull may be splined by giving the command

command=>GET-NEW-DATA

After which the user will be prompted for file names containing new input data. Otherwise, exit from VELSPL by giving the command

command=>EXIT

B.5 CHANGING THE DEFAULTS

Although the defaults have been chosen with care and will work adequately most of the time, it is virtually impossible to have a set of defaults which will work for the flow around every hull. Hence, VELSPLE allows the expert user to change the default values.

The defaults may be grouped into two broad classes: those which may be different for each spline calculated, and those which must be the same for all splines in a given direction, the global defaults. An example of the former is the error associated with any particular data point. An example of the latter is the number of knots. The global defaults must be set before any splining begins. The remaining defaults may be changed as the splining proceeds. The default values which may be changed are described in detail in Appendices B.4.1 to B.4.8.

If it is desired to change defaults as the splining proceeds the command

command=>PLOT-EACH-SPLINE

must be given. After each spline has been calculated, it is plotted and a sub-command mode entered. Non-global defaults may be changed by appropriate sub-commands described below. The prompt in the sub-command mode is

sub-command=>

After changes have been made to the defaults at the sub-command level, the spline may be recalculated by giving the command

sub-command=>RESPLINE

Only the spline for the current station or spline row will be recalculated. If the spline is satisfactory, the spline of the station or spline row is obtained by giving the sub-command

sub-command=>CONTINUE

Since there are typically 40 or 50 splines calculated, it is often tedious to change defaults for every spline when, perhaps, only the splines at one or two stations will cause difficulty. For this reason, arguments may be given to the command PLOT-EACH-SPLINE:

command=>PLOT-EACH-SPLINE *station/spline-row number*

where *station/spline-row* is one of

STATION or SPLINE-ROW

and *number* is the number of the station or spline row. The splines will then be calculated without plotting until the indicated station or spline row is reached. All splines will then be plotted until plotting is suppressed by the sub-command

sub-command=>SUPPRESS-PLOTS *station/spline-row number*

This command causes the suppression of plotting until the indicated station or spline row

is reached. If no arguments are given, VELSP will complete its calculations without plotting further splines.

Once a non-global default is changed, the new value usually remains as the default until changed again. There are exceptions to this rule, however, so it is usually best to check the default descriptions below.

B.5.1 CHANGING THE AMOUNT OF SMOOTHING

The splines calculated by VELSP are smoothing splines and hence, the desired amount of smoothing must be specified; that is, the splines will not go exactly through the data points but will pass close to them. The distance the spline is allowed to be from the data points must be specified. This is done by establishing an appropriate chi-square for the spline. The chi-square is not a global variable and may be changed at both the command and sub-command levels. At both levels the appropriate command is

command=>CHANGE AMOUNT-OF-SMOOTHING *method*

where *method* is one of

FOR-ALL-STATIONS, FOR-ALL-X-SPLINES, or CALCULATED-FROM-DATA

The commands FOR-ALL-STATIONS and FOR-ALL-X-SPLINES both require an argument: a number equal to the chi-square for each of the splines of the stations or the spline rows respectively.

The command CALCULATED-FROM-DATA indicates that the chi-square for each spline is to be calculated internally by the function PRERR in the BSPLIN:HLLYSP library⁴. This is the default. Once changed the default for the amount of smoothing remains at its new value until changed again. If the chi-square is calculated from the data by PRERR, all subsequent splines will also call PRERR until the chi-square is changed explicitly by the user.

B.5.2 CHANGING THE DATA POINT ERRORS

Each data point has an error associated with it: the smaller the error, the closer the spline will try to come to its corresponding data point. Note that the errors are relative, their values being modulated by the value of the chi-square of the spline (see the previous section): that is, by changing the error of a data point you can make the spline come closer or farther away from the data point associated with it, but the overall chi-square of the spline will not change. Changing all data point errors by the same multiplicative factor (e.g. doubling each of them) will not affect the spline at all. The data point errors are non-global parameters and may be changed at both command and sub-command levels. At the command level the errors can be changed only by setting them all equal to a single value. The appropriate command is

command=>CHANGE MEAN-ERROR *value*

where *value* is the value which the errors are to assume. Default for this value is 1. At the sub-command level the command for changing the errors is

sub-command=>CHANGE ERRORS *method*

where *method* is one of

ALL-EQUAL or INTERACTIVE-SPECIFICATION

The command ALL-EQUAL causes the value of all errors to be set to the global default value.

The command INTERACTIVE-SPECIFICATION allows the changing of the errors of individual data points via the cross-hair sub-sub-command mode (see Appendix B.2). Upon giving the command the data points of the current spline are replotted and the cross-hair appears as a prompt for a single letter command. The available commands are

- 1) E or e : Exit from the cross-hair sub-sub-command mode to the sub-command mode.
- 2) N or n : A new value for the error of the data point closest to the cross-hair may be entered. A line is drawn from the data point identified to the value typed in. The line allows the user to remember which error value is associated with which data point.
- 3) O or o : The old value of the error of the data point closest to the cross-hair is printed on the screen somewhat above or below the cross-hair position.
- 4) P or p : Plots the data points again. After several errors have been changed, the screen can get cluttered with old and new error values. This command allows the screen to be cleared of all these numbers.
- 5) ? : Causes a list of possible commands to be written above the plot.

The errors once changed remain fixed until the program progresses from splining stations to splining spline rows. At that time the the errors are all set equal to their global default value.

B.5.3 CHANGING THE ORDER OF THE SPLINES

The order of the splines of the stations and the order of the splines of the spline rows are global parameters which may be changed by the command

command=>CHANGE *order-type order*

where *order-type* is one of

S-ORDER or X-ORDER

and *order* is the new order of the appropriate spline type. X-ORDER refers to the splines of the stations (the splines in the x-direction) while S-ORDER refers to the splines of the spline rows (the splines in the s-direction).

The order of the splines should be changed before changing the knots (see Appendix B.5.4) as the order of the spline is used when calculating the knots. If the knots are changed before the orders are changed a warning message will be printed. The default value for the orders of the splines in both directions is 4.

B.5.4 CHANGING THE KNOTS

The knots for the spline are global parameters, so that they may only be changed before the splining begins. The knots for the splines of the stations and the knots for the splines of the spline rows are specified separately.

The command to change the knots is

```
command=>CHANGE knot-type method
```

where *knot-type* is one of

X-KNOTS or S-KNOTS

and indicates that the knots for stations or spline rows, respectively, are to be changed. *method* is one of

EQUALLY-SPACED, FROM-FILE, or NOT-A-KNOT

The command EQUALLY-SPACED requires an argument, the number of knots. Hence, the command

```
command=>CHANGE X-KNOTS EQUALLY-SPACED 15
```

indicates that the splines of the spline rows (the splines in the x-direction) are to use 15 equally spaced knots.

The command FROM-FILE indicates that the knots are to be read from a file. A prompt is given for the file from which the knots are to be read. The knots are read by an unformatted READ as follows:

```
READ (UNIT,*)NKT, (T(I), I=1,NKT)
```

NKT is the number of knots and the array T contains the values of the knots.

The command NOT-A-KNOT indicates that the knots are to be evaluated by the not-a-knot condition³. This condition ensures that the number of B-splines is exactly equal to the number of points being splined.

The default for the knots for the splines of the stations is that they be equally spaced with the number of knots equal to the average number of data points per station. The default for the knots for the splines of the spline rows is that they be calculated by the not-a-knot condition.

B.5.5 CHANGING THE STIFFNESS WEIGHTS

Each spline may be altered by the specification of input parameters called stiffness weights. There $N-k+1$ stiffness weights (N is the number of B-splines in the spline, and k is the order of the spline) corresponding to the intervals between the knots t_k, \dots, t_{N+1} . By increasing the stiffness weight associated with a given interval, the spline will become "stiffer" over that interval: that is, the curve will tend to be straighter. If the stiffness weight is decreased the spline will become more pliant over the associated interval and will bend more easily. Spline wiggles may be avoided successfully by making the stiffness weights high where the data is very regular and low where the data is changing rapidly. Like the data point errors, the values of the stiffness weights are relative: changing them all by the same multiplicative factor will not alter the spline at all. More complete information on the stiffness weights and the manner in which they are implemented in the spline algorithms is given by Hally⁴.

The stiffness weights are non-global parameters which can be changed at both the command and sub-command levels. At the command level give the command

command=>CHANGE STIFFNESS-WEIGHTS *method*

where *method* is one of

ALL-EQUAL, INTERACTIVE-SPECIFICATION or CALCULATED-FROM-DATA

The command ALL-EQUAL sets all the stiffness weights to 1. Since only the relative values of the stiffness weights are important, there is no need to allow the setting of all stiffness weights to a value other than 1.

The command INTERACTIVE-SPECIFICATION allows the changing of individual stiffness weights via the cross-hair sub-sub-command mode (see Appendix B.2). Upon giving the command the data points of the current spline are replotted and the cross-hair appears as a prompt for a single letter command. The position of the knots for the spline are indicated by the row of crosses at the bottom of the plot. There is a stiffness weight associated with each knot interval. The available commands are

- 1) E or e : Exit from the cross-hair sub-sub-command mode to the sub-command mode.
- 2) N or n : A new value for the stiffness weight of the knot interval identified by the vertical cross-hair may be entered. A line is drawn from the centre of the knot interval to the position of the cross-hair. The line allows the user to remember which value is associated with which knot interval.
- 3) O or o : The old value of the stiffness weight of the knot interval identified by the vertical cross-hair is printed at the position of the cross-hair.
- 4) P or p : Plots the data points again. After several stiffness weights have been changed, the screen can get cluttered with old and new stiffness weight values. This command allows the screen to be cleared of all these numbers.

5) ? : Causes a list of possible commands to be written above the plot.

The command CALCULATED-FROM-DATA indicates that the stiffness weights for each spline are to be calculated by the subroutine WTIBEG in the BSPLIN:HLLYSP library⁴. This is the default.

New values for the stiffness weights remain as defaults until changed again by the user. If the stiffness weights are calculated from the data by WTIBEG, all subsequent splines will also call WTIBEG until the stiffness weights are changed explicitly by the user.

B.5.6 CHANGING THE SMOOTHING DERIVATIVE

The smoothing splines try to minimize a high order derivative of the spline⁴. The order of the derivative minimized is a non-global parameter which can be changed at either the command or the sub-command level. The appropriate command is identical in each case:

command=>CHANGE SMOOTHING-DERIVATIVE *smoothing-derivative*

where *smoothing derivative* is the new value of the derivative. In order that the spline be smooth, the derivative should have a value greater than 1. Default value is 2.

A new value for the smoothing derivative remains as the default until it is changed again.

B.5.7 CHANGING THE TERMINAL AND PLOTTER TYPE

As described in Appendix B.1, upon entering VELSP the user is prompted for the type of terminal and plotter being used. If the user wishes to change terminal or plotter types at any time (typically the user will first check the plot on the terminal screen, alter it to his liking, then change the plotter type from the terminal to a plotter in order to produce a hard copy) he may do so by giving the command

TERMINAL=

which will trigger the same set of prompts and responses as occurred at the beginning of the program.

Appendix C

CALCULATING STREAMLINES FROM CONTRAVARIANT VELOCITY COMPONENTS

Let $X(t)$ be a streamline parametrized by some parameter t : that is, for all values of t , $X(t)$ lies on the streamline. Then dX/dt is a vector parallel to the flow vector V . A vector perpendicular to V is

$$V^\perp = v^2 e^1 - v^1 e^2 \quad (C.1)$$

whence the condition that $(x(t), s(t))$ is a streamline may be written

$$\frac{dX}{dt} \cdot V^\perp = 0 \quad (C.2)$$

But,

$$\frac{dX}{dt} = \frac{\partial X}{\partial x} \cdot \frac{dx}{dt} + \frac{\partial X}{\partial s} \cdot \frac{ds}{dt} = e^1 \frac{dx}{dt} + e^2 \frac{ds}{dt} \quad (C.3)$$

Hence, equation (C.2) may be written

$$v^2 \frac{dx}{dt} - v^1 \frac{ds}{dt} = 0 \quad (C.4)$$

or

$$\frac{ds}{dx} = \frac{v^1}{v^2} \quad (C.5)$$

If the contravariant velocity components at each point on the hull are known, this equation is easily integrated to yield the streamlines.

References

1. Hally,D.; "Numerical Approximation of Ship Hulls", DREA Technical Memorandum, in preparation
2. Hally,D.; "An Integral Method for the Calculation of Boundary Layer Growth on a Ship Hull", DREA Technical Memorandum, in preparation
3. de Boor,C.; A Practical Guide to Splines, Springer Verlag, New York, 1978
4. Hally,D.; "A New Library Of Spline Routines", DREA Technical Memorandum, in preparation
5. Hess,J.L.; Smith,A.M.O.; "Calculation of Non-lifting Potential Flow about Arbitrary Three-dimensional Bodies", Douglas Aircraft Co. Report E.S. 40622, March 1962
6. Hunt,B. (editor); Numerical Methods in Applied Fluid Dynamics , Academic Press, 1980
7. Lamb,H.; Hydrodynamics, Cambridge University Press, 1953
8. Sears,W.R. (editor); General Theory of High Speed Aerodynamics , Volume VI, Princeton University Press, 1954
9. Labrujere,Th.E.; Loeve,W.; Slooff,J.W.; "An Approximate Method for the Calculation of the Pressure Distribution on Wing-Body Combinations at Subcritical Speeds", AGARD CP-71-71, Paper 11, January 1971
10. Hally,D.; "User's Guide for DSPHLL, OFFSET, and STMHLC: Programs for Graphic Display of Ship Hulls and Potential Flows Around Them", DREA Technical Memorandum, in preparation
11. Hally,D.; Dent,C.A.; "GETWRD Package", DREA Tech. Memo. 84/D
12. Tektronix Inc.; Document Nos. 062-1474-00, 062-1530-00

Subject Index

- => 30
- ALL-EQUAL 35, 37
- AMOUNT-OF-SMOOTHING 34
- CALCULATED-FROM-DATA 34, 37, 38
- CHANGE 33-38
- Compressibility correction 6
- CONTINUE 33
- Coordinate systems 2-3, 6-7
- Cross-hair sub-command mode 31, 35, 37-38
- Defaults, changing of 33-38
- Defaults, global 33, 35-36
- Defaults, non-global 33-35, 37-38
- DSPHLL 28
- EEOUT.DAT 21, 22, 25
- EN967A 15, 18
- EN967B 15, 18
- EN967C 2, 16, 18-19, 20, 21, 22, 23, 24
- EN967C.DAT 15, 17, 18, 19
- EN967D 2, 18, 20-21, 22, 23
- EN967D.DAT 15, 17, 18, 20
- EN967E 2, 18, 20, 21-22, 23, 31
- EN967E.DAT 15, 17, 18, 21
- EN967S 2, 8, 15-18, 19, 20, 21, 22, 23, 25, 31
- EQUALLY-SPACED 36
- ERRORS 35
- EXIT 31, 32
- FOR-ALL-STATIONS 34
- FOR-ALL-X-SPLINES 34
- FROM-FILE 36
- GET-NEW-DATA 32
- GETWRD Package 28, 30
- Gothert's rule 6
- INTERACTIVE-SPECIFICATION 35, 37
- Knot defaults 36
- Knots of splines 8-9
- MEAN-ERROR 34
- NAME* files 15, 20, 22
- NAME10.DAT 19, 20, 23
- NAME11.DAT 19, 21, 23
- NAME12.DAT 18, 21
- NAME13.DAT 19, 21, 23
- NAME15.DAT 19, 20, 23
- NAME16.DAT 21
- NAME17.DAT 18, 31
- NAME18.DAT 18, 23
- NAME24.DAT 18, 19, 21
- NAME30.DAT 22, 25, 31, 32
- NAME7.DAT 18, 19, 23
- NAME9.DAT 18, 19
- NOT-A-KNOT 36
- Order of splines 8, 35-36
- Order of splines, defaults 36
- PLOT-EACH-SPLINE 33
- Prandtl-Glauert equation 6
- PRERR 34
- Prompts for input 30
- RESPLINE 33
- S-KNOTS 36
- S-ORDER 35
- Smoothing derivative 38
- Smoothing derivative, default 38
- SMOOTHING-DERIVATIVE 38
- Spline knots 36
- Spline rows 32, 33
- SPLINE-ROW 33
- START 31
- STATION 33
- STIFFNESS-WEIGHTS 37
- STMHLC 28
- sub-command=> 33
- SUPPRESS-PLOTS 33

Terminal types 28, 38
TERMINAL= 38

VELACC.DAT 32
VELSPL 2

WTIBEG 38

X-KNOTS 36
X-ORDER 35

UNCLASSIFIED

Security Classification

DOCUMENT CONTROL DATA - R & D		
<small>(Security classification of title, body of abstract and indexing annotation must be entered when the overall document is classified)</small>		
1. ORIGINATING ACTIVITY DEFENCE RESEARCH ESTABLISHMENT ATLANTIC	2a. DOCUMENT SECURITY CLASSIFICATION UNCLASSIFIED	
	2b. GROUP	
3. DOCUMENT TITLE THE CALCULATION OF POTENTIAL FLOW ABOUT SHIP HULLS		
4. DESCRIPTIVE NOTES (Type of report and inclusive dates) MACKAY, MICHAEL., HALLY, DAVID		
5. AUTHOR(S) (Last name, first name, middle initial)		
6. DOCUMENT DATE MAY 1985	7a. TOTAL NO. OF PAGES 50	7b. NO. OF REFS 14
8a. PROJECT OR GRANT NO. A847	8b. ORIGINATOR'S DOCUMENT NUMBER(S) DREA TECHNICAL MEMORANDUM 85/204	
8b. CONTRACT NO.	9b. OTHER DOCUMENT NO.(S) (Any other numbers that may be assigned this document)	
10. DISTRIBUTION STATEMENT UNLIMITED DISTRIBUTION		
11. SUPPLEMENTARY NOTES	12. SPONSORING ACTIVITY	
13. ABSTRACT		
<p>This memorandum is the second of three which describe a series of computer programs for the calculation of the growth of a boundary layer on a ship hull. The first described computer programs for the numerical approximation of ship hulls using smoothing splines. This memorandum describes the calculation of the potential flow around the numerically approximated hulls. The third memorandum will describe the calculation of the boundary layer growth.</p> <p>The potential flow is calculated using a first-order panel method which yields the cartesian components of the flow vector at a number of control points on the hull. These discrete cartesian flow vectors are converted to contravariant velocity components and splined to yield a continuous representation of the potential flow over the hull. Zero Froude number is assumed.</p> <p>User guides are given for programs implementing the panel method and for a program which splines the calculated velocities.</p>		

17813
16-470

KEY WORDS

Hydrodynamics
 Ship Hulls
 Potential Flow
 Splines
 Computer Programs

INSTRUCTIONS

1. **ORIGINATING ACTIVITY:** Enter the name and address of the organization issuing the document.
- 2a. **DOCUMENT SECURITY CLASSIFICATION:** Enter the overall security classification of the document including special warning terms whenever applicable.
- 2b. **GROUP:** Enter security reclassification group number. The three groups are defined in Appendix M of the DRB Security Regulations.
3. **DOCUMENT TITLE:** Enter the complete document title in all capital letters. Titles in all cases should be unclassified. If a sufficiently descriptive title cannot be selected without classification, show title classification with the usual one-capital-letter abbreviation in parentheses immediately following the title.
4. **DESCRIPTIVE NOTES:** Enter the category of document, e.g. technical report, technical note or technical letter. If appropriate, enter the type of document, e.g. interim, progress, summary, annual or final. Give the inclusive dates when a specific reporting period is covered.
5. **AUTHOR(S):** Enter the name(s) of author(s) as shown on or in the document. Enter last name, first name, middle initial. If military, show rank. The name of the principal author is an absolute minimum requirement.
6. **DOCUMENT DATE:** Enter the date (month, year) of Establishment approval for publication of the document.
- 7a. **TOTAL NUMBER OF PAGES:** The total page count should follow normal pagination procedures. I.e., enter the number of pages containing information.
- 7b. **NUMBER OF REFERENCES:** Enter the total number of references cited in the document.
- 8a. **PROJECT OR GRANT NUMBER:** If appropriate, enter the applicable research and development project or grant number under which the document was written.
- 8b. **CONTRACT NUMBER:** If appropriate, enter the applicable number under which the document was written.
- 9a. **ORIGINATOR'S DOCUMENT NUMBER(S):** Enter the official document number by which the document will be identified and controlled by the originating activity. This number must be unique to this document.
- 9b. **OTHER DOCUMENT NUMBER(S):** If the document has been assigned any other document numbers (either by the originator or by the sponsor), also enter this number(s).
10. **DISTRIBUTION STATEMENT:** Enter any limitations on further dissemination of the document, other than those imposed by security classification, using standard statements such as:
 - (1) "Qualified requesters may obtain copies of this document from their defence documentation center."
 - (2) "Announcement and dissemination of this document is not authorized without prior approval from originating activity."
11. **SUPPLEMENTARY NOTES:** Use for additional explanatory notes.
12. **SPONSORING ACTIVITY:** Enter the name of the departmental project office or laboratory sponsoring the research and development. Include address.
13. **ABSTRACT:** Enter an abstract giving a brief and factual summary of the document, even though it may also appear elsewhere in the body of the document itself. It is highly desirable that the abstract of classified documents be unclassified. Each paragraph of the abstract shall end with an indication of the security classification of the information in the paragraph (unless the document itself is unclassified) represented as (TS), (S), (C), (R), or (U).

The length of the abstract should be limited to 20 single-spaced standard typewritten lines; 7 1/2 inches long.
14. **KEY WORDS:** Key words are technically meaningful terms or short phrases that characterize a document and could be helpful in cataloging the document. Key words should be selected so that no security classification is required. Identifiers, such as equipment model designation, trade name, military project code name, geographic location, may be used as key words but will be followed by an indication of technical context.

END

FILMED

9-85

DTIC