

AD-A158 113

A MATHEMATICAL DESCRIPTION OF THE SUN-MOON
TRANSFORMATION ANGLE SUPPORT SOFTWARE PACKAGE(U) NAVAL
SURFACE WEAPONS CENTER DAHLGREN VA A D PARKS SEP 82
NSWC/TR-82-389 F/G 17/7

1/1

UNCLASSIFIED

NL

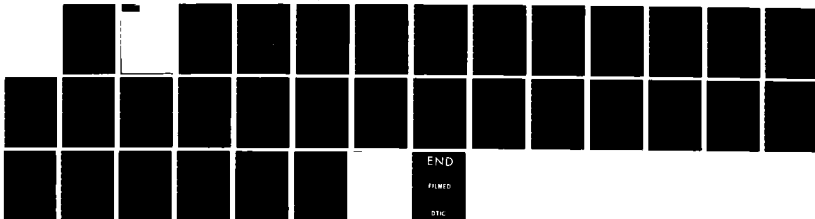

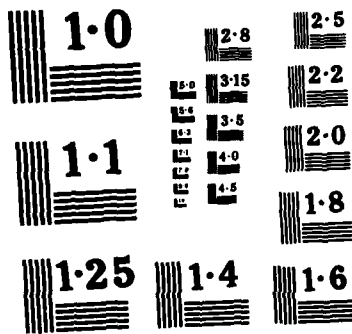

NATIONAL BUREAU OF STANDARDS
MICROCOPY RESOLUTION TEST CHART

AD-A158 113

UNCLASSIFIED

SECURITY CLASSIFICATION OF THIS PAGE (When Data Entered)

REPORT DOCUMENTATION PAGE		READ INSTRUCTIONS BEFORE COMPLETING FORM
1. REPORT NUMBER NSWC TR 82-389	2. GOVT ACCESSION NO. AD A158 113	3. RECIPIENT'S CATALOG NUMBER
4. TITLE (and Subtitle) A MATHEMATICAL DESCRIPTION OF THE SUN-MOON TRANSFORMATION ANGLE SUPPORT SOFTWARE PACKAGE		5. TYPE OF REPORT & PERIOD COVERED Final
		6. PERFORMING ORG. REPORT NUMBER
7. AUTHOR(s) A. D. PARKS		8. CONTRACT OR GRANT NUMBER(s)
9. PERFORMING ORGANIZATION NAME AND ADDRESS Naval Surface Weapons Center (K13) Dahlgren, VA 22448		10. PROGRAM ELEMENT, PROJECT, TASK AREA & WORK UNIT NUMBERS 63701B
11. CONTROLLING OFFICE NAME AND ADDRESS Defense Mapping Agency Washington, DC 20370		12. REPORT DATE September 1982
		13. NUMBER OF PAGES 33
14. MONITORING AGENCY NAME & ADDRESS (if different from Controlling Office)		15. SECURITY CLASS. (of this report) UNCLASSIFIED
		15a. DECLASSIFICATION/DOWNGRADING SCHEDULE
16. DISTRIBUTION STATEMENT (of this Report) Approved for public release; distribution unlimited		
17. DISTRIBUTION STATEMENT (of the abstract entered in Block 20, if different from Report)		
18. SUPPLEMENTARY NOTES		
19. KEY WORDS (Continue on reverse side if necessary and identify by block number) Sun-Moon transformation angle software package PULSAR Doppler satellite Inertial solar and lunar position vectors and nutation angles		
20. ABSTRACT (Continue on reverse side if necessary and identify by block number) A mathematical and functional description of the Sun-Moon-Transformation angle support software package is presented. This software package constructs a file on magnetic tape of inertial solar and lunar position vectors and nutation angles, as well as values for the obliquity of the ecliptic and the equation of the equinoxes. These data may be generated in either the B1950.0 or the J2000.0 reference systems and are intended for use by the PULSAR Doppler Satellite tracking data editor.		

DD FORM 1473
1 JAN 73EDITION OF 1 NOV 65 IS OBSOLETE
S/N 0102-LF-014-6601

UNCLASSIFIED

SECURITY CLASSIFICATION OF THIS PAGE (When Data Entered)

FOREWORD

This report has been prepared to present a formal description of the Sun-Moon-Transformation angle support software package. This package constructs a magnetic tape file of inertial solar and lunar position vectors and nutation angles. Values for the obliquity of the ecliptic and the equation of the equinoxes are also computed and stored. These data may be generated in either the B1950.0 or the J2000.0 reference systems and are intended for use by the PULSAR Doppler satellite tracking data editor.

Released by:

O. F. Braxton

O. F. BRAXTON, Head

Strategic Systems Department

Account for	
NTIS	<input checked="" type="checkbox"/>
DTIC	<input type="checkbox"/>
Unannounced	<input type="checkbox"/>
Justification	<input type="checkbox"/>
By _____	
Distribution _____	
Availability _____	
Dist	_____
A-1	_____

DTIC
COPY
INSPECTED
3

CONTENTS

<u>Section</u>		<u>Page</u>
1.0	Introduction	1
2.0	The Process Control Function (PCF)	4
	2.1 Functional Description	4
	2.2 Processing Equations and SMT File Format	4
3.0	The Sun-Moon Ephemeris Generator (SMEG)	8
	3.1 Functional Description	8
	3.2 Processing Equations	8
4.0	The Transformation Angle Generator (TAG)	13
	4.1 Functional Description	13
	4.2 Processing Equations	13

ILLUSTRATIONS

<u>Figure</u>		<u>Page</u>
1-1	SMTS Functional Overview and Data Flow	2
2-1	Process Control Function Logic Flow.	5
3-1	Sun-Moon Ephemeris Generator Process Flow	9
4-1	Transformation Angle Generator Process Flow	14

TABLES

<u>TABLE</u>		<u>Page</u>
2-1	SMT Tape Format	7
4-1	Constants Required to Compute Fundamental Sun-Moon Angles .	17
4-2	Integer Multiples and Coefficients Required to Compute $\Delta\psi$ and $\Delta\epsilon$ In the B1950.0 Reference System	18
4-3	Integer Multiples and Coefficients Required to Compute $\Delta\psi$ and $\Delta\epsilon$ in the J2000.0 Reference System	21

SECTION 1

INTRODUCTION

This document provides a basic overview of the computational functions of the sun-moon-transformation angle support software (SMTS). This software package was designed, documented and implemented by members of the Space Flight Sciences Branch of the Space and Surface Systems Division at the Naval Surface Weapons Center (NSWC)/Dahlgren, Virginia.

The primary function of the SMTS package is to construct a tape file containing inertial solar (\vec{r}_{sun}) and lunar (\vec{r}_{moon}) position vectors and the transformation angles ($\Delta\psi$, ϵ , $\Delta\epsilon$, ΔH) needed to rotate between the earth-centered inertial and the earth-centered earth-fixed coordinate reference frames. These data may be generated in either the B1950.0 or the J2000.0 reference systems. The transformation angles and the solar position vectors are generated once a day at 0^h, whereas the lunar position vectors are generated twice a day at 0^h and 12^h. The resulting tape file is intended for use by the PULSAR Doppler Satellite tracking data editor¹.

A functional overview of the SMTS package is shown in Figure 1-1. As can be seen from this figure, the SMTS package is comprised of three basic computational functions: the process control function (PCF), the sun-moon ephemeris generator (SMEG), and the transformation angle generator (TAG). Also shown on this figure is the primary inter-function data flow. A descriptive overview of each of these functions is presented in the following sections.

As input the SMTS package requires a standard Jet Propulsion Laboratory (JPL) export tape. Also needed are the year (YRB) and day number (DAYB) to begin the sun-moon file; the year (YRE) and day number (DAYE) to end the sun-moon

¹ Parks, A.D. and Hicks, T.I., A Mathematical Description of the PULSAR Doppler Satellite Tracking Data Editor, NSWC/DL TR 82-391, Dahlgren, Virginia, 1982.

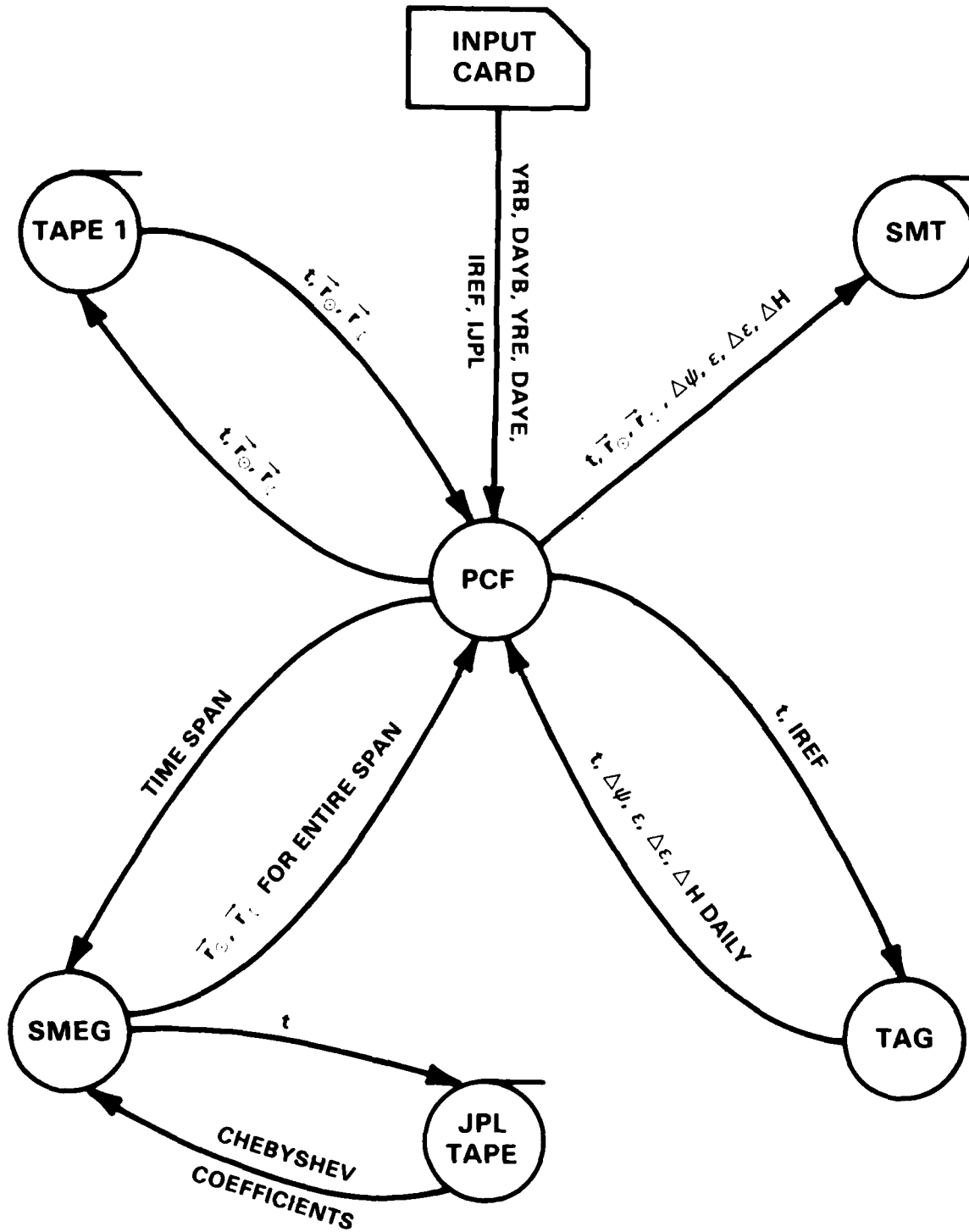

FIGURE 1-1. SMTS FUNCTIONAL OVERVIEW AND DATA FLOW

1.0 INTRODUCTION (con't)

file; a switch (IREF) to select either the J2000.0 or B1950.0 reference system; and a flag (IJPL) to inform SMTS which reference system (i.e. J2000.0 or B1950.0) the JPL export tape is based upon.

In order to initiate its processing, the SMTS reads a single data card specifying YRB, DAYB, YRE, DAYE, IREF, and IJPL. The JPL tape is accessed and sun and moon position vectors are generated for the entire time span using Chebyshev expansions. These vectors are then stored in a temporary file (TAPE1). The transformation angles are generated on a daily basis and merged with the associated sun and moon position vectors on the final sun-moon-transformation angle tape (SMT).

SECTION 2

THE PROCESS CONTROL FUNCTION (PCF)

2.1 FUNCTIONAL DESCRIPTION

The principal tasks performed by the PCF are to receive and retrieve data, direct processing flow, and output the desired SMT file. Specifically the PCF:

- (i) receives data from the input card;
- (ii) converts input times to Julian days;
- (iii) determines the time span for which to construct a SMT tape;
- (iv) calls SMEG to produce sun-moon position vectors for the required time span and write them to a temporary file;
- (v) calls TAG to compute transformation angles for the span of interest; and
- (vi) merge the sun-moon position vectors with the transformation angles to form the SMT tape.

The flow of the PCF function is presented in Figure 2-1.

2.2 PROCESSING EQUATIONS AND SMT FILE FORMAT

The input data is read from the single input card and the beginning Julian day, JD_B , and processing span, ΔT , are computed as follows:

$$JD_B = 367. YRB - \text{INT} \left[(7 YRB)/4. \right] + DAYB + 1721043.5 \quad (2.1)$$

and

$$\Delta T = 366.(YRE - YRB + 1) \quad (2.2)$$

The time in Julian Centuries used by the TAG function to generate the associated transformation angles is computed using

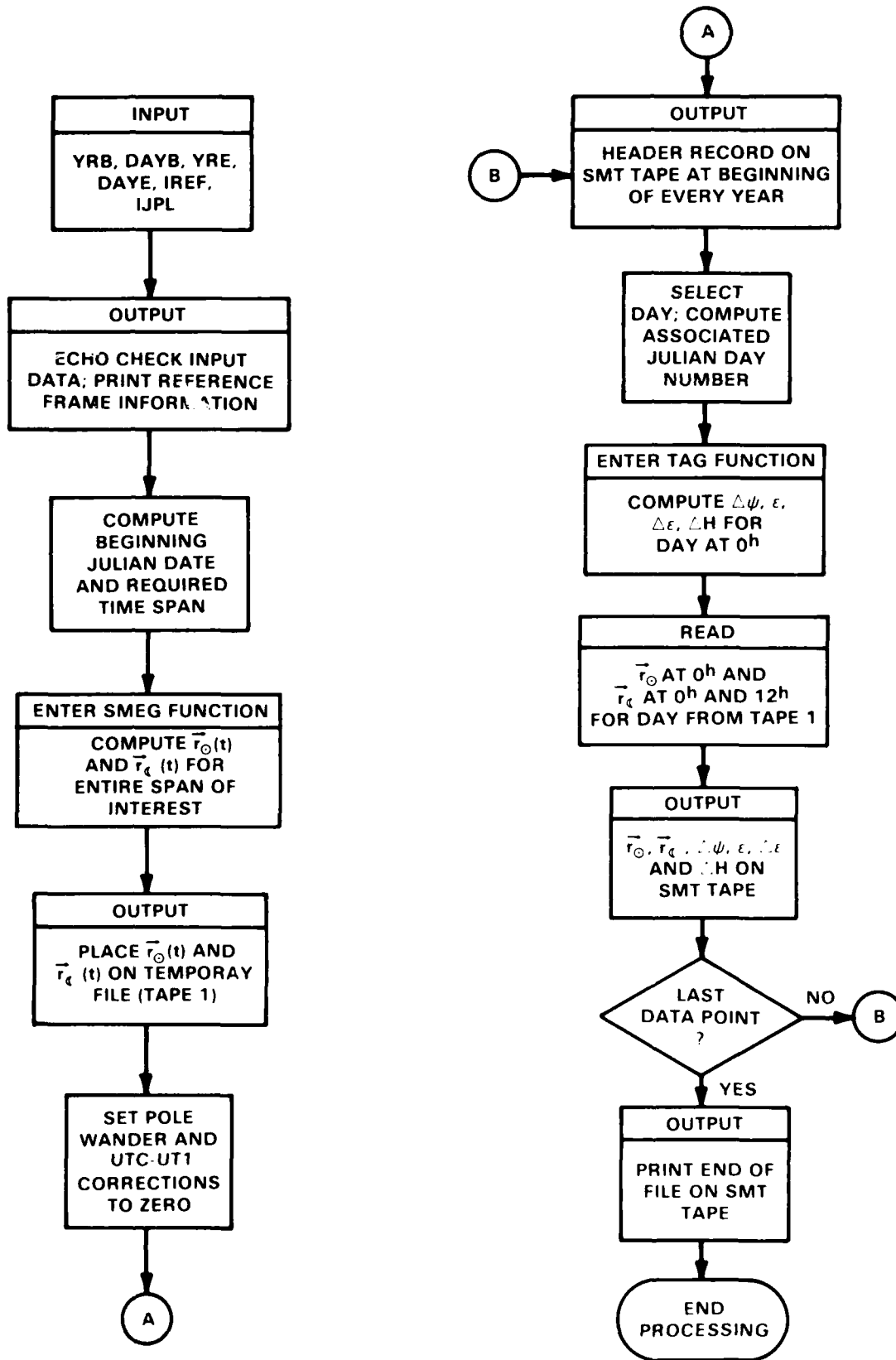

FIGURE 2-1. PROCESS CONTROL FUNCTION LOGIC FLOW

2.2 PROCESSING EQUATIONS AND SMT FILE FORMAT (con't)

$$\tau = \left(\frac{JD_C - 2451545.0}{36525.} \right) , \quad (2.3)$$

where JD_C is the current Julian Ephemeris Date for the time of interest and is computed using an expression analagous to equation (2.1). This is the same τ used in SECTION 4.0.

The format for the SMT tape is given in Table 2-1. It should be mentioned that the pole wander corrections, Δp and Δq , and the UT1-UTC, Δt , corrections are zeroed out on the file. This is done because these quantities are computed and predicted internally by PULSAR (see SECTION 2.2.3 in reference 1).

TABLE 4-2. INTEGER MULTIPLES AND COEFFICIENTS REQUIRED TO COMPUTE $\Delta\psi$ AND $\Delta\epsilon$ IN THE B1950.0 REFERENCE SYSTEM (con't)

i	n_{1i}	n_{2i}	n_{3i}	n_{4i}	n_{5i}	$\Delta\psi$		$\Delta\epsilon$	
						α_i	β_i	γ_i	δ_i
1	0	0	0	1	0	- 4.0	0.0	0.0	0.0
2	0	1	0	-2	0	- 4.0	0.0	0.0	0.0
3	1	0	-2	0	0	4.0	0.0	0.0	0.0
4	2	0	0	-2	1	4.0	0.0	- 2.0	0.0
5	0	1	2	-2	1	3.0	0.0	- 2.0	0.0
6	1	1	0	0	0	- 3.0	0.0	0.0	0.0
7	1	-1	0	-1	0	- 2.0	0.0	0.0	0.0
8	-1	-1	2	2	2	- 2.0	0.0	0.0	0.0
9	0	-1	2	2	2	- 2.0	0.0	0.0	0.0
0	1	-1	2	0	2	- 3.0	0.0	0.0	0.0
1	3	0	2	0	2	- 2.0	0.0	0.0	0.0
2	-2	0	2	0	2	- 3.0	0.0	2.0	0.0
3	1	0	2	0	0	3.0	0.0	0.0	0.0
4	1	0	0	0	2	- 2.0	0.0	0.0	0.0
5	-1	0	2	-2	1	- 2.0	0.0	0.0	0.0
6	0	-2	2	-2	1	- 4.0	0.0	2.0	0.0
7	-2	0	0	0	1	- 2.0	0.0	0.0	0.0
8	2	0	0	0	1	2.0	0.0	0.0	0.0
9	1	1	2	0	2	2.0	0.0	0.0	0.0

TABLE 4-2. INTEGER MULTIPLES AND COEFFICIENTS REQUIRED TO COMPUTE
 $\Delta\psi$ AND $\Delta\epsilon$ IN THE B1950.0 REFERENCE SYSTEM (con't)

n_{1i}	n_{2i}	n_{3i}	n_{4i}	n_{5i}	$\Delta\psi$		$\Delta\epsilon$	
					α_i	β_i	γ_i	δ_i
0	0	2	-2	0	-21.0	0.0	0.0	0.0
-1	0	2	0	1	19.0	0.0	-10.0	0.0
0	2	0	0	0	15.9	-0.1	0.0	0.0
0	2	2	-2	2	-14.9	0.1	7.0	0.0
-1	0	0	2	1	14.0	0.0	-7.0	0.0
0	1	0	0	1	-15.0	0.0	8.0	0.0
1	0	0	-2	1	-13.0	0.0	7.0	0.0
0	-1	0	0	1	-10.0	0.0	5.0	0.0
2	0	-2	0	0	10.0	0.0	0.0	0.0
-1	0	2	2	1	- 9.0	0.0	5.0	0.0
1	0	2	2	2	- 6.0	0.0	3.0	0.0
0	-1	2	0	2	- 6.0	0.0	3.0	0.0
0	0	2	2	1	- 5.0	0.0	3.0	0.0
1	1	0	-2	0	- 7.0	0.0	0.0	0.0
0	1	2	0	2	7.0	0.0	- 3.0	0.0
-2	0	0	2	1	- 5.0	0.0	3.0	0.0
0	0	0	2	1	- 6.0	0.0	3.0	0.0
2	0	2	-2	2	6.0	0.0	- 2.0	0.0
1	0	0	2	0	6.0	0.0	0.0	0.0
1	0	2	-2	1	5.0	0.0	- 3.0	0.0
0	0	0	-2	1	- 5.0	0.0	3.0	0.0
0	-1	2	-2	1	- 5.0	0.0	3.0	0.0
2	0	2	0	1	- 4.0	0.0	2.0	0.0
1	-1	0	0	0	4.0	0.0	0.0	0.0
1	0	0	-1	0	- 3.0	0.0	0.0	0.0

TABLE 4-2. INTEGER MULTIPLES AND COEFFICIENTS REQUIRED TO COMPUTE $\Delta\psi$ AND $\Delta\epsilon$ IN THE B1950.0 REFERENCE SYSTEM

i	n_{1i}	n_{2i}	n_{3i}	n_{4i}	n_{5i}	$\Delta\psi$		$\Delta\epsilon$	
						α_i	β_i	γ_i	δ_i
1	0	0	0	0	1	-172500.7	-173.7	92109.1	9.1
2	0	0	2	-2	2	-12730.3	-1.3	5519.1	-2.9
3	0	0	2	0	2	-2037.2	-0.2	883.5	-0.5
4	0	0	0	0	2	2088.2	0.2	-903.6	0.4
5	0	1	0	0	0	1257.9	-3.1	0.0	0.0
6	1	0	0	0	0	675.1	0.1	0.0	0.0
7	0	1	2	-2	2	-495.8	1.2	215.4	-0.6
8	0	0	2	0	1	-342.4	-0.4	183.0	0.0
9	1	0	2	0	2	-261.0	0.0	112.9	-0.1
10	0	-1	2	-2	2	213.5	-0.5	-92.7	0.3
11	1	0	0	-2	0	-149.0	0.0	0.0	0.0
12	0	0	2	-2	1	124.1	0.1	-66.0	0.0
13	-1	0	2	0	2	114.0	0.0	-50.0	0.0
14	1	0	0	0	1	58.0	0.0	-31.0	0.0
15	0	0	0	2	0	60.0	0.0	0.0	0.0
16	-1	0	2	2	2	-52.0	0.0	22.0	0.0
17	-1	0	0	0	1	-57.0	0.0	30.0	0.0
18	1	0	2	0	1	-44.0	0.0	23.0	0.0
19	2	0	0	-2	0	45.0	0.0	0.0	0.0
20	-2	0	2	0	1	45.0	0.0	-24.0	0.0
21	0	0	2	2	2	-32.0	0.0	14.0	0.0
22	2	0	2	0	2	-26.0	0.0	11.0	0.0
23	2	0	0	0	0	28.0	0.0	0.0	0.0
24	1	0	2	-2	2	26.0	0.0	-11.0	0.0
25	0	0	2	0	0	25.0	0.0	0.0	0.0

TABLE 4-1. CONSTANTS REQUIRED TO COMPUTE FUNDAMENTAL SUN-MOON ANGLES (*)

λ	C_1	C_2	C_3	C_4	C_5
ℓ	.0518	33.22454	715923.1253	485866.52179	1325.0
	.064	31.31	715922.633	485866.733	1325.0
ℓ'	-.0108	-.5724	1292577.984	1287091.548	99.0
	-.012	-.5770	1292581.224	1287099.804	99.0
Ω	0.0	7.504	-482896.246	450156.048	5.0
	.008	7.455	-482890.539	450160.28	5.0
d	.0068	-5.1496	1105600.86	1072261.66679	1236.
	.019	-6.891	1105601.32	1072261.307	1236.
F	-.0012	-11.5636	295267.4164	335782.17879	1342.
	.011	-13.257	295263.137	335778.877	1342.

(*) The upper entry applies for the B1950.0 reference system. The lower entry applies for the J2000.0 reference system.

4.2 PROCESSING EQUATIONS (con't)

$$\epsilon = \bar{\epsilon} + \Delta\epsilon \quad , \quad (4.8)$$

where

$$\bar{\epsilon}(\circ) = \begin{cases} 23.439280808 + [(5.036 \times 10^{-7}\tau - 1.31 \times 10^{-7})\tau - .013014269]\tau, \text{ B1950.0} \\ 23.4392911111 + [(5.036 \times 10^{-7}\tau - 1.639 \times 10^{-7})\tau - .0130041667]\tau, \text{ J2000.0} \end{cases} \quad (4.9)$$

and

$$\Delta H = \tan^{-1} [\tan\Delta\psi \cos \epsilon] \quad . \quad (4.10)$$

4.2 PROCESSING EQUATIONS (con't)

In the last two equations

$$t = \text{Julian Ephemeris Date, J2000.0} \quad , \quad (4.5)$$

$$t_0 = 2451545.0 \quad , \quad \text{J2000.0} \quad , \quad (4.6)$$

the n_{j_i} ($j = 1, 2, \dots, 5$) are integers and:

ℓ is the mean elongation of the moon from the sun;

ℓ' is the mean argument of latitude of the moon;

F is the mean anomaly of the sun;

d is the mean anomaly of the moon; and

Ω is the mean longitude of the ascending node of the moon.

These angular quantities are computed in units of seconds of arc from expressions having the following form:

$$\lambda = [(C_1\tau + C_2)\tau + C_3]\tau + C_4 \pm 1296000.000 \text{ mod } (C_5\tau, 1.000), \quad (4.7)$$

where τ is given by equation (4.3) and the constants C_i ($i = 1, 2, \dots, 5$) are given in Table 4-1. The plus sign after C_4 applies for all cases except when $\lambda = \Omega$, in which case the minus sign applies. Values for the α_i , β_i , γ_i , δ_i , and n_{j_i} of equations (4.1), (4.2), and (4.4) are given in Tables 4-2 and 4-3 for the B1950.0 and J2000.0 reference systems, respectively.

The obliquity of the ecliptic, ϵ , and the equation of the equinoxes, ΔH , are computed using

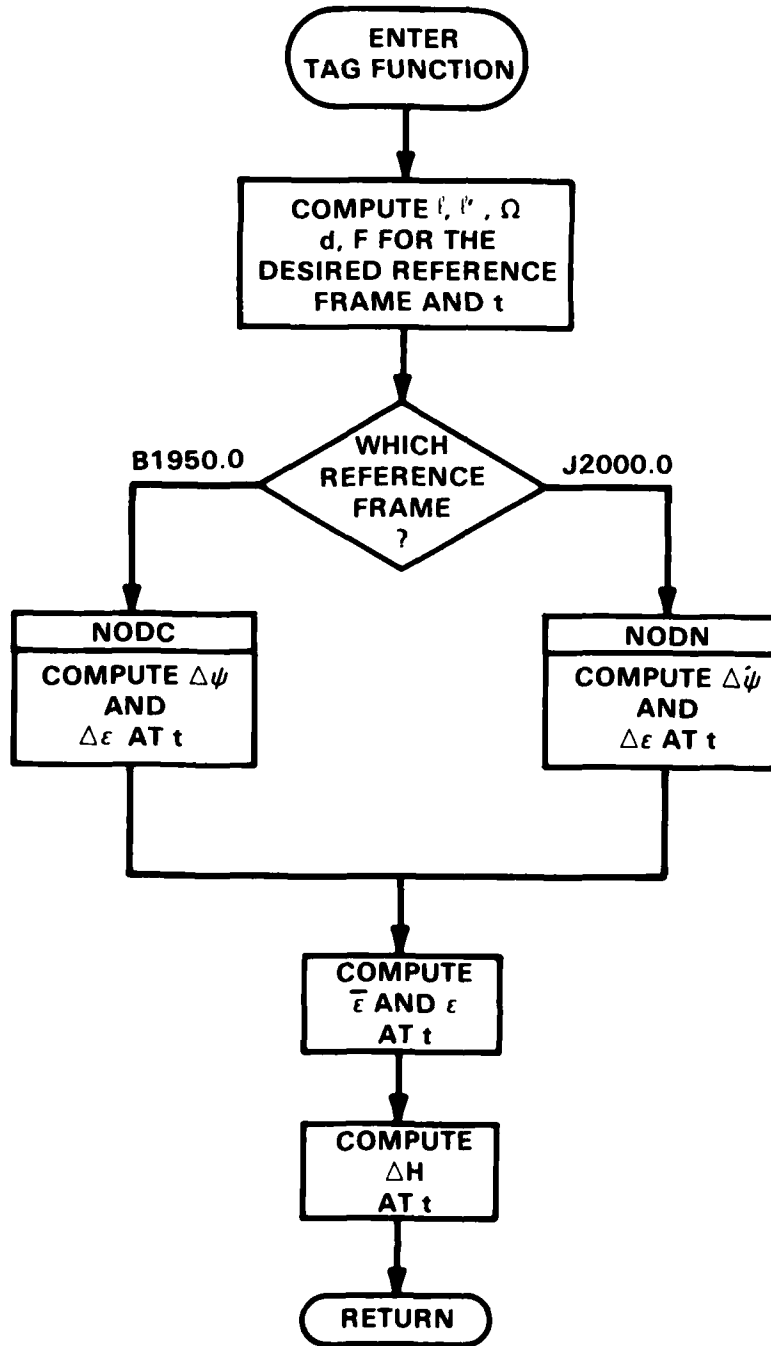

FIGURE 4-1. TRANSFORMATION ANGLE GENERATOR PROCESS FLOW

SECTION 4

THE TRANSFORMATION ANGLE GENERATOR (TAG)

4.1 FUNCTIONAL DESCRIPTION

The transformation angle generator computes on a daily basis at 0^h the nutation in longitude, $\Delta\psi$; the nutation in obliquity, $\Delta\epsilon$; the obliquity of the ecliptic, ϵ ; and the equation of the equinoxes, ΔH . As the angles are computed, they are merged with \vec{r}_{sun} and \vec{r}_{moon} on the SMT tape. These angles may be computed in either the B1950 or the J2000 reference frame by setting the IREF flag. The process flow of the TAG function is shown in Figure 4-1.

4.2 PROCESSING EQUATIONS

The nutation in longitude, $\Delta\psi$, and the nutation in obliquity, $\Delta\epsilon$, in seconds of arc are computed in both reference systems using the following expansions:

$$\Delta\psi = 10^{-4} \sum_{i=1}^N (\alpha_i + \beta_i \tau) \sin \theta_i \quad (4.1)$$

and

$$\Delta\epsilon = 10^{-4} \sum_{i=1}^N (\gamma_i + \delta_i \tau) \cos \theta_i \quad (4.2)$$

($N = 69$ for the B1950.0 system and $N = 106$ for the J2000.0 system) where

$$\tau = \frac{t - t_0}{36525.0} \quad (4.3)$$

and

$$\theta_i = n_{1i} \ell + n_{2i} \ell' + n_{3i} F + n_{4i} d + n_{5i} \Omega \quad (4.4)$$

3.2 PROCESSING EQUATIONS (con't)

It is best if the JPL development ephemeris DE118 is used to obtain the $\vec{r}_\ell(B1950)$ in equation (3.12).

3.2 PROCESSING EQUATIONS (con't)

where the $\beta_{\ell jk}$ and $\gamma_{\ell jk}$ are the Chebyshev expansion coefficients. The velocity and acceleration polynomials are obtained by differentiating recursion relation (3.4), i.e.

$$\dot{T}_{n+1} = 2t_c \dot{T}_n - \dot{T}_{n-1} + 2T_n \quad (3.10)$$

and

$$\ddot{T}_{n+1} = 2t_c \ddot{T}_n - \ddot{T}_{n-1} + 4\dot{T}_n \quad (3.11)$$

As was mentioned earlier, if desired, it is possible to transform the sun and moon between the J2000.0 and B1950.0 reference systems by setting the IJPL flag. These transformations are given by²:

$$\vec{r}_\ell(\text{J2000}) = \tilde{R} \vec{r}_\ell(\text{B1950}), \quad (\ell = \text{sun, moon}) \quad (3.12)$$

and

$$\vec{r}_\ell(\text{B1950}) = \tilde{R}^T \vec{r}_\ell(\text{J2000}), \quad (\ell = \text{sun, moon}), \quad (3.13)$$

where

$$\tilde{R} = \begin{bmatrix} 0.9999256791774783 & -0.0111815116768724 & -0.0048590038154553 \\ 0.0111815116989975 & 0.9999374845751042 & -0.0000271625775175 \\ 0.0048590037714450 & -0.0000271704492210 & 0.9999881946023742 \end{bmatrix} \quad (3.14)$$

² Standish, Jr., E. Myles, Orientation of the JPL Ephemerides, DE200/LE200, To The Dynamical Equinox of J2000, privately obtained pre-print, April, 1982.

3.2 PROCESSING EQUATIONS (con't)

Recursion relations are used to generate the Chebyshev polynomials T_n at t_c :

$$T_{n+1} = 2t_c T_n - T_{n-1} \quad , \quad (3.4)$$

where

$$T_0 = 1 \quad , \quad (3.5)$$

and

$$T_1 = 2t_c \quad . \quad (3.6)$$

The j^{th} position components for the sun and moon at t are given by

$$(\vec{r}_\ell)_j = \sum_{k=0}^m \alpha_{\ell j k} T_k \quad , \quad (\ell = \text{sun, moon}; j = 1, 2, 3), \quad (3.7)$$

where $\alpha_{\ell j k}$ is the associated Chebyshev expansion coefficient valid for the interval $[t_s, t_E]$ and obtained from the JPL tape.

It should be mentioned that, although they are not used to construct the SMT tape, the velocity and acceleration for the sun and moon can also be obtained from the SMEG function:

$$(\dot{\vec{r}}_\ell)_j = \sum_{k=0}^m \beta_{\ell j k} \dot{T}_k \quad , \quad (\ell = \text{sun, moon}; j = 1, 2, 3) \quad (3.8)$$

and

$$(\ddot{\vec{r}}_\ell)_j = \sum_{k=0}^m \gamma_{\ell j k} \ddot{T}_k \quad , \quad (\ell = \text{sun, moon}; j = 1, 2, 3) \quad (3.9)$$

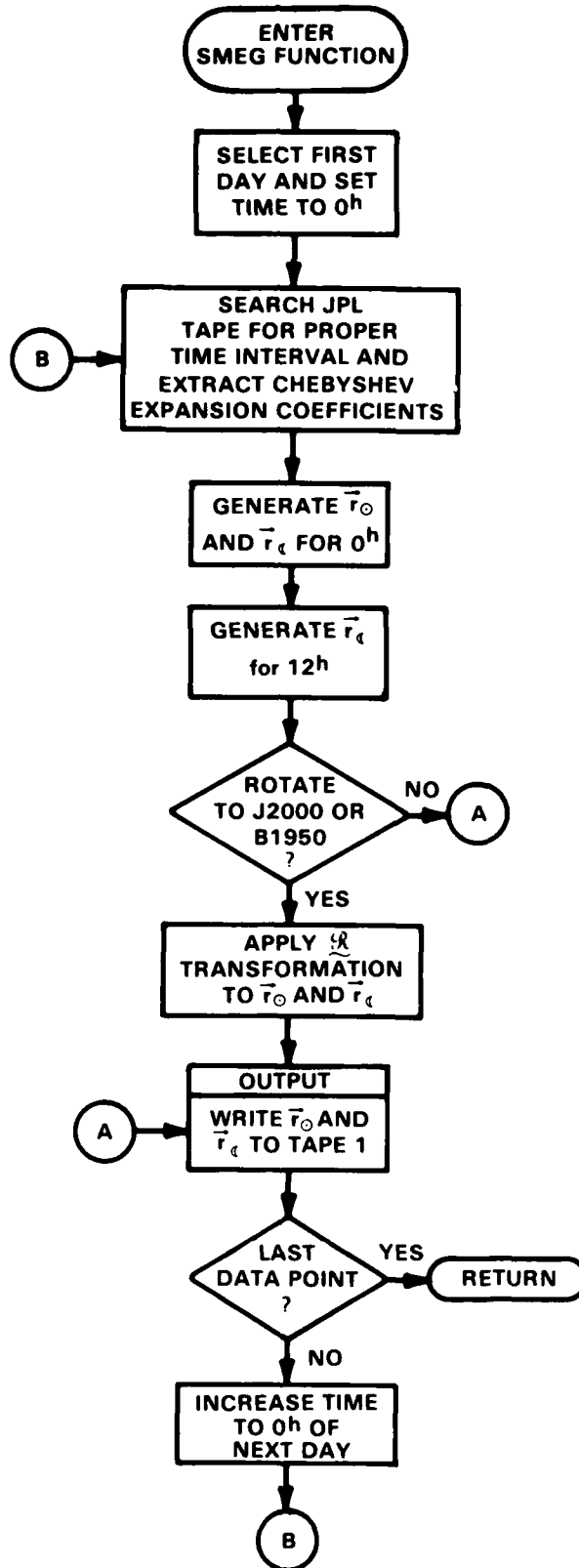

FIGURE 3-1 SUN-MOON EPHEMERIS GENERATOR PROCESS FLOW

SECTION 3

THE SUN-MOON EPHEMERIS GENERATOR (SMEG)

3.1 FUNCTIONAL DESIGN

The sun-moon ephemeris generation function is used by the SMTS package to provide diurnal solar location vectors and semi-diurnal lunar location vectors. These vectors are computed using Chebyshev expansions and are stored on a temporary data file before being merged with the transformation angle data. It should be mentioned that if desired, the IJPL flag may be set to transform the position vectors to the J2000.0 reference system, if initially expressed in the B1950.0 reference system; or to the B1950.0 reference system, if initially expressed in the J2000.0 system. Of course, care must be taken to insure that the same reference system is being used consistently for the sun and moon position vectors and the transformation angles when constructing the SMT tape. The fundamental SMEG processing flow is shown in Figure 3-1.

3.2 PROCESSING EQUATIONS

Values for sun and moon position coordinates are obtained in SMEG using expansions in Chebyshev polynomials. The coefficients required for these expansions are read from the JPL tape and are valid over certain time subintervals of the span covered by the tape. For a time t in a subinterval $[t_s, t_E]$, i.e. for

$$t_s \leq t \leq t_E \quad , \quad (3.1)$$

a Chebyshev time, t_c , is computed from

$$t_c = \frac{2t - t_E - t_s}{t_E - t_s} \quad , \quad (3.2)$$

such that

$$-1 \leq t_c \leq 1 \quad . \quad (3.3)$$

Table 2-1. SMT Tape Format

RECORD	NUMBER OF WORDS IN RECORD	VARIABLE	DESCRIPTION
Header	3	REC1	Record Type = 110XXX* for the B1950.0 system = 210XXX for the J2000.0 system
		YRA ₁	Year Number
		YRA ₂	Number of days in block
Data	20	REC2	Record Type = 111XXX for the B1950.0 system = 211XXX for the J2000.0 system
		DAY	Day Number
		SUN	Coordinates of sun at 0 ^h (three words)
		MOON ₁	Coordinates of moon at 0 ^h (three words)
		MOON ₂	Coordinates of moon at 12 ^h (three words)
		DPSI	Nutation in longitude (radians)
		TRUEPS	Obliquity of the ecliptic (radians)
		DEPS	Nutation in obliquity (radians)
		DTS	UT1 - UTC timing correction (seconds)
		DELHT	Equation of the equinoxes (radians)
		P	Polar displacement toward Greenwich (radians)
		Q	Polar displacement west (radians)
DUM 1	Dummy word		
DUM 2	Dummy word		

* XXX = XXXth block of tape

TABLE 4-3. INTEGER MULTIPLES AND COEFFICIENTS REQUIRED TO COMPUTE $\Delta\psi$ AND $\Delta\epsilon$ IN THE J2000.0 REFERENCE SYSTEM

i	n_{1i}	n_{2i}	n_{3i}	n_{4i}	n_{5i}	$\Delta\psi$		$\Delta\epsilon$	
						α_i	β_i	γ_i	δ_i
1	0	0	0	0	1	-171996.	-174.2	92025.	8.9
2	0	0	2	-2	2	-13187.	-1.6	5736.	-3.1
3	0	0	2	0	2	-2274.	-0.2	977.	-0.5
4	0	0	0	0	2	2062.	0.2	-895.	0.5
5	0	1	0	0	0	1426.	-3.4	54.	-0.1
6	1	0	0	0	0	712.	0.1	- 7.	0.0
7	0	1	2	-2	2	-517.	1.2	224.	-0.6
8	0	0	2	0	1	-386.	-0.4	200.	0.0
9	1	0	2	0	2	-301.	0.0	129.	-0.1
10	0	-1	2	-2	2	217.	-0.5	-95.	0.3
11	1	0	0	-2	0	-158.	0.0	- 1.	0.0
12	0	0	2	-2	1	129.	0.1	-70.	0.0
13	-1	0	2	0	2	123.	0.0	-53.	0.0
14	1	0	0	0	1	63.	0.1	-33.	0.0
15	0	0	0	2	0	63.	0.0	- 2.	0.0
16	-1	0	2	2	2	-59.	0.0	26.	0.0
17	-1	0	0	0	1	-58.	-0.1	32.	0.0
18	1	0	2	0	1	-51.	0.0	27.	0.0
19	2	0	0	-2	0	48.	0.0	1.	0.0
20	-2	0	2	0	1	46.	0.0	-24.	0.0
21	0	0	2	2	2	-38.	0.0	16.	0.0
22	2	0	2	0	2	-31.	0.0	13.	0.0
23	2	0	0	0	0	29.	0.0	-1.	0.0
24	1	0	2	-2	0	29.	0.0	-12.	0.0

TABLE 4-3. INTEGER MULTIPLES AND COEFFICIENTS REQUIRED TO COMPUTE $\Delta\psi$ AND $\Delta\epsilon$ IN THE J2000.0 REFERENCE SYSTEM (con't)

i	n_{1i}	n_{2i}	n_{3i}	n_{4i}	n_{5i}	$\Delta\psi$		$\Delta\epsilon$	
						α_i	β_i	γ_i	δ_i
25	0	0	2	0	0	26.	0.0	-1.	0.0
26	0	0	2	-2	0	-22.	0.0	0.	0.0
27	-1	0	2	0	1	21.	0.0	-10.	0.0
28	0	2	0	0	0	17.	-0.1	0.	0.0
29	0	2	2	-2	2	-16.	0.1	7.	0.0
30	-1	0	0	2	1	16.	0.0	-8.	0.0
31	0	1	0	0	1	-15.	0.0	9.	0.0
32	1	0	0	-2	1	-13.	0.0	7.	0.0
33	0	-1	0	0	1	-12.	0.0	6.	0.0
34	2	0	-2	0	0	11.	0.0	0.	0.0
35	-1	0	2	2	1	-10.	0.0	5.	0.0
36	1	0	2	2	2	-8.	0.0	3.	0.0
37	0	-1	2	0	2	-7.	0.0	3.	0.0
38	0	0	2	2	1	-7.	0.0	3.	0.0
39	1	1	0	-2	0	-7.	0.0	0.	0.0
40	0	1	2	0	2	7.	0.0	-3.	0.0
41	-2	0	0	2	1	-6.	0.0	3.	0.0
42	0	0	0	2	1	-6.	0.0	3.	0.0
43	2	0	2	-2	2	6.	0.0	-3.	0.0
44	1	0	0	2	0	6.	0.0	0.	0.0
45	1	0	2	-2	1	6.	0.0	-3.	0.0
46	0	0	0	-2	1	-5.	0.0	3.	0.0
47	0	-1	2	-2	1	-5.	0.0	3.	0.0
48	2	0	2	0	1	-5.	0.0	3.	0.0

TABLE 4-3. INTEGER MULTIPLES AND COEFFICIENTS REQUIRED TO COMPUTE $\Delta\psi$ AND $\Delta\epsilon$ IN THE J2000.0 REFERENCE SYSTEM (con't)

i	n_{1i}	n_{2i}	n_{3i}	n_{4i}	n_{5i}	$\Delta\psi$		$\Delta\epsilon$	
						α_i	β_i	γ_i	δ_i
49	1	-1	0	0	0	5.	0.0	0.	0.0
50	1	0	0	-1	0	-4.	0.0	0.	0.0
51	0	0	0	1	0	-4.	0.0	0.	0.0
52	0	1	0	-2	0	-4.	0.0	0.	0.0
53	1	0	-2	0	0	4.	0.0	0.	0.0
54	2	0	0	-2	1	4.	0.0	-2.	0.0
55	0	1	2	-2	1	4.	0.0	-2.	0.0
56	1	1	0	0	0	-3.	0.0	0.	0.0
57	1	-1	0	-1	0	-3.	0.0	0.	0.0
58	-1	-1	2	2	2	-3.	0.0	1.	0.0
59	0	-1	2	2	2	-3.	0.0	1.	0.0
60	1	-1	2	0	2	-3.	0.0	1.	0.0
61	3	0	2	0	2	-3.	0.0	1.	0.0
62	-2	0	2	0	2	-3.	0.0	1.	0.0
63	1	0	2	0	0	3.	0.0	0.	0.0
64	-1	0	2	4	2	-2.	0.0	1.	0.0
65	1	0	0	0	2	-2.	0.0	1.	0.0
66	-1	0	2	-2	1	-2.	0.0	1.	0.0
67	0	-2	2	-2	1	-2.	0.0	1.	0.0
68	-2	0	0	0	1	-2.	0.0	1.	0.0
69	2	0	0	0	1	2.	0.0	-1.	0.0
70	3	0	0	0	0	2.	0.0	0.	0.0
71	1	1	2	0	2	2.	0.0	-1.	0.0
72	0	0	2	1	2	2.	0.0	-1.	0.0

TABLE 4-3. INTEGER MULTIPLES AND COEFFICIENTS REQUIRED TO COMPUTE $\Delta\psi$ AND $\Delta\epsilon$ IN THE J2000.0 REFERENCE SYSTEM (con't)

i	n_{1i}	n_{2i}	n_{3i}	n_{4i}	n_{5i}	$\Delta\psi$		$\Delta\epsilon$	
						α_i	β_i	γ_i	δ_i
73	1	0	0	2	1	-1.	0.0	0.	0.0
74	1	0	2	2	1	-1.	0.0	1.	0.0
75	1	1	0	-2	1	-1.	0.0	0.	0.0
76	0	1	0	2	0	-1.	0.0	0.	0.0
77	0	1	2	-2	0	-1.	0.0	0.	0.0
78	0	1	-2	2	0	-1.	0.0	0.	0.0
79	1	0	-2	2	0	-1.	0.0	0.	0.0
80	1	0	-2	-2	0	-1.	0.0	0.	0.0
81	1	0	2	-2	0	-1.	0.0	0.	0.0
82	1	0	0	-4	0	-1.	0.0	0.	0.0
83	2	0	0	-4	0	-1.	0.0	0.	0.0
84	0	0	2	4	2	-1.	0.0	0.	0.0
85	0	0	2	-1	2	-1.	0.0	0.	0.0
86	-2	0	2	4	2	-1.	0.0	1.	0.0
87	2	0	2	2	2	-1.	0.0	0.	0.0
88	0	-1	2	0	1	-1.	0.0	0.	0.0
89	0	0	-2	0	1	-1.	0.0	0.	0.0
90	0	0	4	-2	2	1.	0.0	0.	0.0
91	0	1	0	0	2	1.	0.0	0.	0.0
92	1	1	2	-2	2	1.	0.0	-1.	0.0
93	3	0	2	-2	2	1.	0.0	0.	0.0
94	-2	0	2	2	2	1.	0.0	-1.	0.0
95	-1	0	0	0	2	1.	0.0	-1.	0.0
96	0	0	-2	2	1	1.	0.0	0.	0.0

TABLE 4-3. INTEGER MULTIPLES AND COEFFICIENTS REQUIRED TO COMPUTE $\Delta\psi$ AND $\Delta\epsilon$ IN THE J2000.0 REFERENCE SYSTEM (con't)

i	n_{1i}	n_{2i}	n_{3i}	n_{4i}	n_{5i}	$\Delta\psi$		$\Delta\epsilon$	
						α_i	β_i	γ_i	δ_i
97	0	1	2	0	1	1.	0.0	0.	0.0
98	-1	0	4	0	2	1.	0.0	0.	0.0
99	2	1	0	-2	0	1.	0.0	0.	0.0
100	2	0	0	2	0	1.	0.0	0.	0.0
101	2	0	2	-2	1	1.	0.0	-1.	0.0
102	2	0	-2	0	1	1.	0.0	0.	0.0
103	1	-1	0	-2	0	1.	0.0	0.	0.0
104	-1	0	0	1	1	1.	0.0	0.	0.0
105	-1	-1	0	2	1	1.	0.0	0.	0.0
106	0	1	0	1	0	1.	0.0	0.	0.0

DISTRIBUTION

Defense Technical Information Center
Cameron Station
Alexandria, VA 22314 (12)

Library of Congress
ATTN: Gift and Exchange Division (4)
Washington, DC 20540

National Aeronautics and Space Administration
Scientific and Technical Library
Code NHS 22, Rm. BA39
600 Independence Avenue, SW
Washington, DC 20546 (2)

Defense Mapping Agency
ATTN: Mr. Jack Calender (10)
Washington, DC 20305

Defense Mapping Agency
Hydrographic/Topographic Center
ATTN: Mr. Patrick Fell (10)
Washington, DC 20390

Defense Mapping Agency Aerospace Center
ATTN: Dr. Robert Ballew (8)
St. Louis, MO 63118

Naval Electronics Systems Command
Navy Space Project, PME106
Washington, DC 20360 (3)

Office of Chief of Naval Operations
Naval Oceanography Division (NOP-952)
Bldg. 1, U.S. Naval Observatory (2)
Washington, DC 20390

Office of Naval Operations
Navy Space Systems Division (NOP-943) (2)
Washington, DC 20350

Naval Research Laboratory
ATTN: Mr. Al Bartholomew (3)
Washington, DC 20375

Naval Oceanographic Office
Bay St. Louis, MS 39522 (2)

END

FILMED

9-85

DTIC