

AD-A158 882 NEUTRON STRESS MEASUREMENTS WITH A POSITION SENSITIVE 1/1  
DETECTOR(U) NORTHWESTERN UNIV EVANSTON IL DEPT OF  
MATERIALS SCIENCE A D KRAWITZ ET AL. AUG 85 TR-20  
UNCLASSIFIED N00014-80-C-0116 F/G 18/4 NL

				END								
				FILMED								
				DTIC								

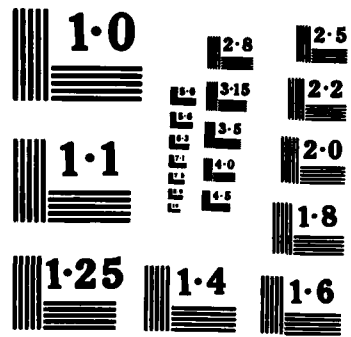

NATIONAL BUREAU OF STANDARDS  
MICROCOPY RESOLUTION TEST CHART

1

# NORTHWESTERN UNIVERSITY

## DEPARTMENT OF MATERIALS SCIENCE

TECHNICAL REPORT # 20  
AUGUST 1985

OFFICE OF NAVAL RESEARCH  
CONTRACT # N00014-80-C-116

AD-A158 882

NEUTRON STRESS MEASUREMENTS WITH A POSITION SENSITIVE DETECTOR

by

A. D. Krawitz, P. J. Rudnik, B. D. Butler and J. B. Cohen

Distribution of this document  
is unlimited

Reproduction in whole or in part  
is permitted for any purpose of  
the United States Government

DTIC FILE COPY



EVANSTON, ILLINOIS

SEP 1 1985

85 9 09 140

# NEUTRON STRESS MEASUREMENTS WITH A POSITION SENSITIVE DETECTOR

A. D. Krawitz\*, P. J. Rudnik\*\*, B. D. Butler\*, and J. B. Cohen\*\*

\* Dept. of Mechanical and Aerospace Engineering, University of Missouri, Columbia, MO 65211.

\*\* Dept. of Materials Science and Engineering, Northwestern University, Evanston, IL 60201.

## INTRODUCTION

The feasibility of measuring residual and applied stresses with neutrons employing a position sensitive detector (PSD) is demonstrated. Measurements with both a small beam, to probe internal regions, and a large beam, for bulk sampling have been made. With such a detector collection of data is rapid compared to ordinary neutron collection methods. This detector allows more detailed sampling, smaller probe regions and possibly even study of time-dependent processes.

## EXPERIMENTAL ASPECTS

The spectrometer geometry is shown in Fig. 1a. The detector consists of a three-counter array of linear PSD's spanning a usable angular range of  $25^\circ 2\theta$  at a distance of 1220 mm from the sample position. The detectors are stacked in a vertical plane which is normal to the horizontal diffraction plane. The front of the detector housing has an oscillating radial collimator which greatly reduces background and off-axis scattering. The data is rebinned into  $0.1^\circ 2\theta$  increments from the basic channel width of  $\approx 0.03^\circ$  and the intensity of the three detectors is added. Further details of the PSD may be found in ref. 1.

For probing small internal regions a special slit geometry is required. In order that a probe region be defined and the beam allowed to reach the PSD, the diffracted beam slit must be placed as close as possible to the sample. The detailed geometry is shown in Fig. 1b. The basic constraints are the needs to define a probe region of a specified dimension and to allow sufficient divergence through the slit to record the entire peak of interest, including shifts due to elastic strain. The parameters of interest are related by:

$$\tan(\alpha/2) = (w_d/2)/l_d = (w_s/2)/l_s$$

where  $w_d$  is the distance along the detector to subtend  $\alpha^\circ$  ( $= 21 \text{ mm}/^\circ$  at the center),  $l_d$  is the distance from the goniometer center to the detector (1220 mm),  $w_s$  is the width of the diffraction slit, and  $l_s$  is the distance from the

goniometer center to the diffraction slit. The slits in the incident and diffracted beams define the internal probe region, or the "diffraction volume." Rectangular slits define a parallelepiped while square slits define a rhomboid. The probe region is fixed over the center of the diffractometer circle, and the sample must be translated in order to examine different interior volumes.

For most detectors, the measured intensities are due only to the particular peak of interest. However, because of the large angular range of the PSD, it is quite easy to obtain additional Bragg peaks at the same time due to crossfire through the diffracted beam slit. This is illustrated schematically in Fig. 2a for the U-shaped aluminum sample described below. The PSD is centered on the 311 peak at  $63.5^\circ 2\theta$  for 0.1285 nm neutrons. As the sample is translated through the probe region at the center of the goniometer, first the 222 then the 220 can pass through the diffracted beam slit, in addition to the 311. Actual results are shown in Fig. 2b for a U-shaped Al alloy bar. Probably the most important consequence of the geometry required for measurements using a PSD is that if the peak of interest is not precisely in the center of the PSD, then displacement of the diffraction slit will lead to shifts in peak position. Such an error in positioning may be due either to inaccurate placement of the detector or mechanical error in positioning of the sample stage or goniometer. This means that the width and position of the diffraction slit should be sufficient to encompass the entire peak of interest over the full range of stress under investigation and that the diffraction slit should not be moved during the measurement.

All of the data was collected on the automated powder diffractometer at the University of Missouri Research Reactor (MURR) using a neutron wavelength of 0.1285 nm. All scans were run under computer control. Data acquisition with the PSD was performed for a preset number of monitor counts which depended on the scattering cross-section of the sample, slit size and desired counting statistics. For example, in small beam experiments, the Al 311 peak was counted for about 12 minutes while the broader 511/333 required about 54 minutes. The peaks were fit to a Gaussian function,  $y = a(\exp[-(x-c)^2/2b^2])$ , where  $a$  is the peak intensity,  $b$  the breadth (FWHM) and  $c$  the peak position (in  $^\circ 2\theta$ ).

## SMALL BEAM (INTERNAL PROBE REGION) EXPERIMENTS

### Blade Fixture Experiment

The ferritic iron blade fixture sample consists of alternating blades and gaps; see Fig. 3a. It was designed to help evaluate the resolution of internal probe experiments. The sample was mounted on the diffractometer and moved, using a precision x-y translation stage, in 0.508 mm increments through the incident beam. As the specimen is translated through the probe region, the diffracted intensity from the 211 Fe peak (at  $67^\circ 2\theta$  for the 0.1285 nm neutrons) should oscillate with the period of the fixture. In particular, the blade/gap interfaces should be located at the positions of 50% of the maximum intensity. The results are shown in Fig. 3b. The half-maximum points of intensity are found to be slightly more than six steps apart, in good

agreement with the actual gap widths and with results obtained using a standard detector[2].

### Al Bar Experiment

The second internal probe sample was a 2024-T86 Al alloy bar cut to a "U" shape and having a 25.4 x 25.4 mm cross-section; see Fig. 4a. Stress was applied by tightening the bolt shown in the figure. The stress level was controlled via a strain gauge on the inner surface of the central cross-section; a compressive stress of -413.7 MPa was set. This sample was previously studied in a similar way but using a standard detector[3]. Two experiments were performed in order to evaluate the PSD relative to the conventional detector.

First, the absorption profile of the bar was obtained, using the 311 peak. The sample was displaced into, and eventually through, the probe region. Initially, when the sampled volume is in front of the specimen, only background scattering is detected. The intensity increases as the specimen is moved into the beam, and rapidly reaches a maximum when the probe region is just entirely within the specimen. Beyond this position the intensity decreases due to absorption. This procedure enables the position of the surface of the sample relative to the center of the diffraction circle to be determined since the position of maximum intensity should be equal to one-half the depth of the sampled volume. The results are shown in Fig. 4b. At the point of maximum intensity, the depth was 2.04 mm. Since 4 mm slits were used, the total penetration depth of the probe region was 4.53 mm at the required diffraction angle, implying a depth of 2.26 mm and revealing an error of 0.22 mm in the mechanical positioning of the sample.

Second, the bar was loaded and the resulting stress gradient through the bar was sampled using the two-tilt process[3] for psi values of 0 and 60°. Since the stress is proportional to the peak shift measured at two different psi angles[3],  $\sigma = K(hkl)\Delta 2\theta$ , stresses at varying depths through the material can be measured by repeating the procedure at different sample positions. The through-thickness stress measurement of the 311 peak, using two psi tilts and eight different depths, required less than 5 hours to complete. The actual collection of data represented only 100 minutes of this total; a similar period was needed to rebin the collected data, with the remainder used in changing the measurement parameters, i.e., the psi angle and probe region. The rebinning time has recently reduced to a matter of seconds so that it would be possible now to do these measurements in 2-3 hours.

The results obtained here and those obtained by Schmanck and Krawitz[3] are compared in Fig. 4c. As is apparent, the values are generally very similar, although they deviate as the outer, tensile surface is approached. This is attributed to plastic deformation due to overload of the sample during testing and prior use though it is possible that the small difference in widths of the slits employed is partially responsible. The stress gradient for the 511/333 peak was also measured and found to be of the same shape.

### LARGE BEAM (BULK SAMPLING) EXPERIMENTS

Experiments were conducted using conventional powder diffraction

geometry and a tensile test device for in situ studies of specimens under load. The device can apply 1380 MPa to a 6.35 mm diameter sample having an 88.9 mm gauge length. Load is applied through a worm shaft and worm gear. Each revolution of the worm gear elongates the sample  $7.03 \times 10^{-5}$  mm; the maximum achievable strain is 8%. The applied strain is monitored using a strain gauge attached to the center of the samples.

Measurements of peak position vs. applied stress were performed on a 17-7PH austenitic stainless steel. Stress increments of 138 MPa (20 Ksi) were employed and the 211, 220, 310 and 222 peaks were measured. As these span  $35^\circ 2\theta$ , two settings of the PSD were required; a counting time of about 30 minutes per setting was used. A summary of information is presented in Table I. Figure 5(a) shows a plot of applied stress vs. peak shift for the 211 and 310 peaks. It clearly indicates the elastic anisotropy of the material. An example of a Gaussian peak fit is shown in Fig. 5(b), for the 310 peak under a stress of 276 MPa.

The relative response of the four peaks is shown on a plot of  $\nu/E_2$  values vs. the crystallographic orientation parameter  $(h^2k^2 + k^2l^2 + h^2l^2)/(h^2 + k^2 + l^2)$ ; see Fig. 6. The  $\nu/E$  values were obtained from least-mean-square fits of the slopes of the  $\sigma$  vs.  $\Delta(2\theta)$  plots. Since the measurements were made transversely to the tensile axis,  $\epsilon_{\perp}^{hkl} = (\nu_{hkl}/E_{hkl})\sigma$ , where  $\epsilon_{\perp}^{hkl}$  is the transverse strain for the hkl planes,  $\nu_{hkl}$  and  $E_{hkl}$  are the Poisson ratio and Young's modulus of the hkl planes and  $\sigma$  is the applied stress. Included are the Reuss and Voigt limits. The results appear to follow the more realistic Kroner behavior, which is close to the simple average of the Reuss and Voigt cases.

A related experiment was also performed using this sample. It was loaded well into the plastic region. The material has a yield strength of about 760 MPa, corresponding to a strain of about 0.37% or 3700 $\mu\epsilon$ . The results for the 211 peak are shown in Fig. 7. The plastic response lies between the limiting cases of continued elastic and ideal elastic-plastic responses. This is a strengthened material for which the tensile strength is only about 10% greater than the yield strength so that a rather sharp bend in the stress-strain curve beyond yield is expected and observed. However, the actual yield point seems to be delayed for the particular physical and crystallographic orientations measured. These exploratory data suggest the potential of in situ studies of two-phase or composite systems with regard to mechanical aspects such as load-sharing, constraint effects and in situ yield points.

## CONCLUSIONS

From these experiments we have shown that the PSD in use at the University of Missouri Research Reactor Facility is an important tool for the application of neutron scattering to engineering materials, in addition to its use in more traditional neutron scattering experiments. This is because of the significant savings in data collection time and the increased range of feasible experiments. The resolution and behavior of this instrument has been demonstrated to be on a par with standard detectors.

**ACKNOWLEDGEMENTS**

Mr. Cliff Holmes constructed and helped design the slit system and translation stage for the small beam experiments. Dr. W. Yelon also contributed greatly to the design. The tensile test device was designed by John Hollander and Rich Juergens and constructed by Rich Juergens. PJR thanks his associates at UMC and MURR. This work was performed with the support of MURR and Office of Naval Research contract No. N00014-80-C-116 with Northwestern University.

**REFERENCES**

1. C. W. Tompson, D. F. R. Mildner, M. Mehregany, J. Sudol, R. Berliner and W. B. Yelon, J. Appl. Cryst., 17(1984)
2. A. D. Krawitz, J. E. Brune and M. J. Schmank, "Residual Stress and Stress Relaxation", Eds. E. Kula and V. Weiss, 1982, Plenum Press, New York, pp. 139-156.
3. M. J. Schmank and A. D. Krawitz, Met. Trans. A,13A(1982)1069-1076.

Accession For	
DTIC	<input checked="" type="checkbox"/>
DTIC TAB	<input type="checkbox"/>
Unannounced	<input type="checkbox"/>
Justification	<input type="checkbox"/>
Distribution/	
Availability Codes	
Avail and/or	
Special	
AI	

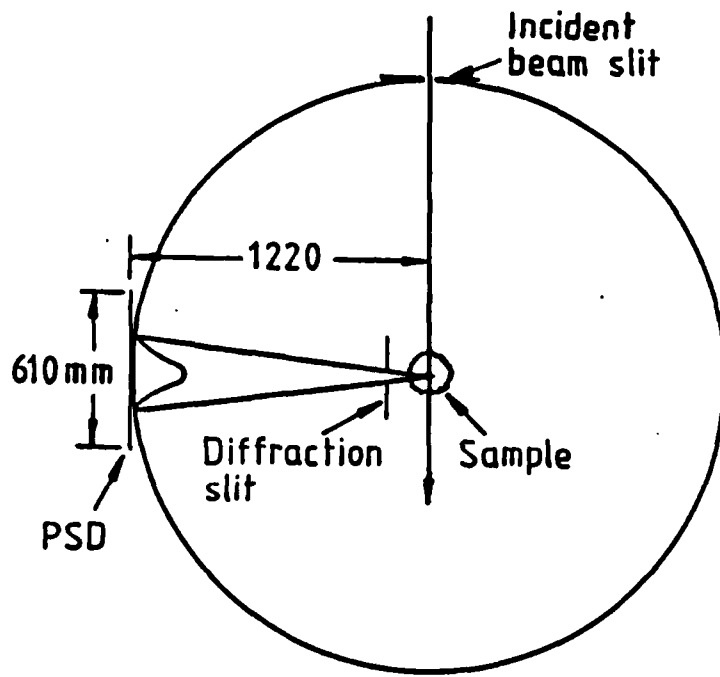

Table I. Some Data for the 17-7PH Steel Sample  
Used in the In Situ Tensile Device

<u>hkl</u>	<u>Unstressed 2θ (°)</u>	<u>Average Peak Intensity (Cts)</u>	<u>Average Error from Gaussian Fits of Peak Position (°2θ)</u>
211	66.6	5700	0.002
220	78.7	1200	.005
310	90.3	2000	.003
222	101.9	900	.008

## FIGURE CAPTIONS

- Fig. 1 (a) Spectrometer geometry for creation of internal probe region using PSD.  
(b) Detail of diffraction path showing parameters for relating size of probe region and usable area of PSD.
- Fig. 2 Crossfire effects using U-shaped Al alloy bar sample. Schematic illustration of (a) presence of 220 and 311 peaks only for shallow beam penetration and (b) inclusion of 222 for deeper beam penetration. Actual results are shown in (c).
- Fig. 3 (a) The blade fixture sample.  
(b) Results of internal probe scan through blade fixture.
- Fig. 4 (a) U-shaped Al alloy bar sample.  
(b) Absorption profile.  
(c) Results of measurement of stress gradient for present study and prior measurement using conventional detector. Maximum statistical error indicated on one data point.
- Fig. 5 (a) Applied stress vs. peak shift for the 211 and 310 peaks of the austenitic stainless steel sample using tensile device.  
(b) Example of Gaussian peak fit for 310 peak under stress of 276 MPa.
- Fig. 6 Plot of  $\nu/E$  vs. the crystallographic orientation parameter for the austenitic stainless steel sample in elastic region.
- Fig. 7 Response of austenitic stainless steel sample (211 peak) in plastic region.



(a)

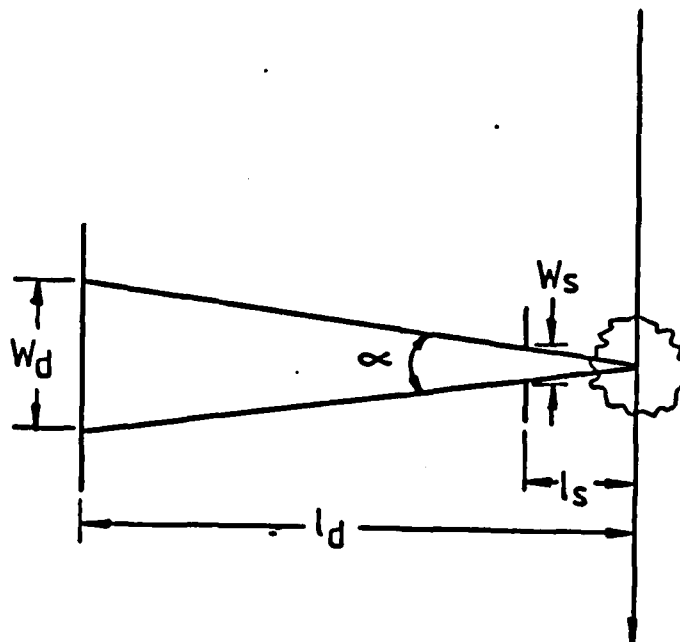

(b)

Fig. 1

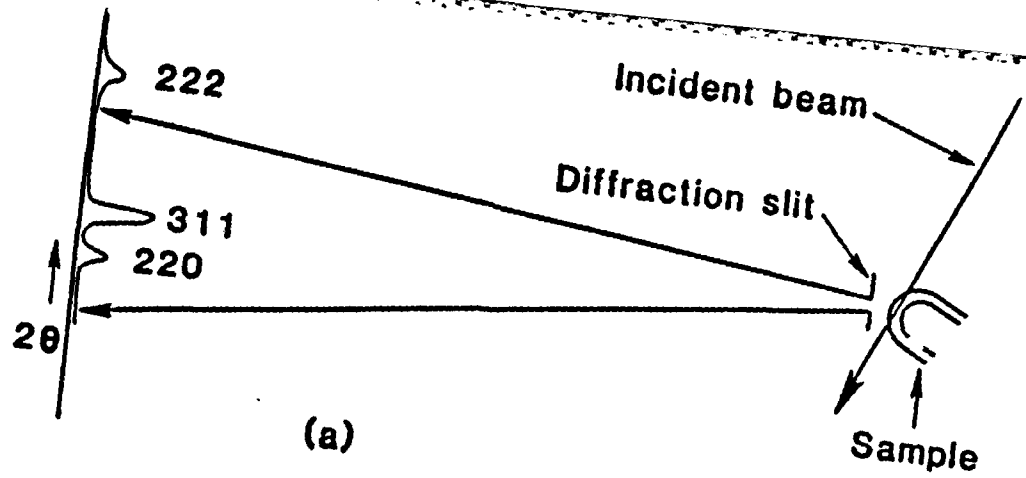

(a)

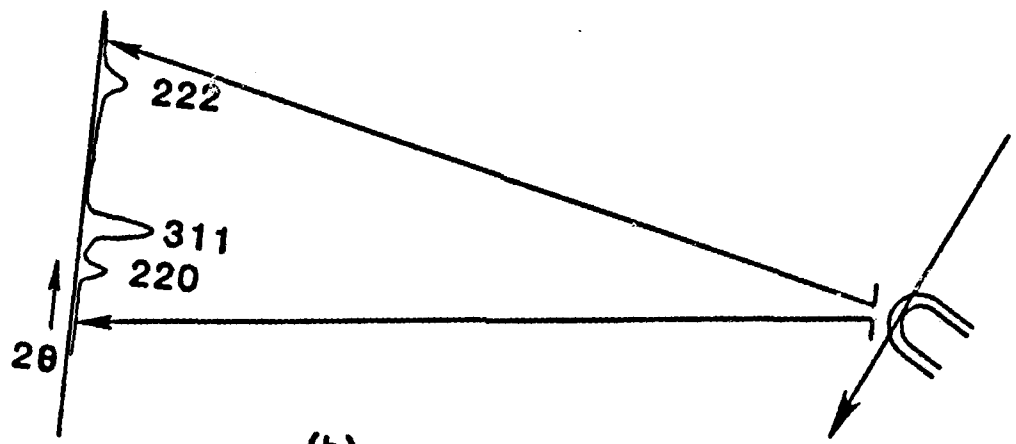

(b)

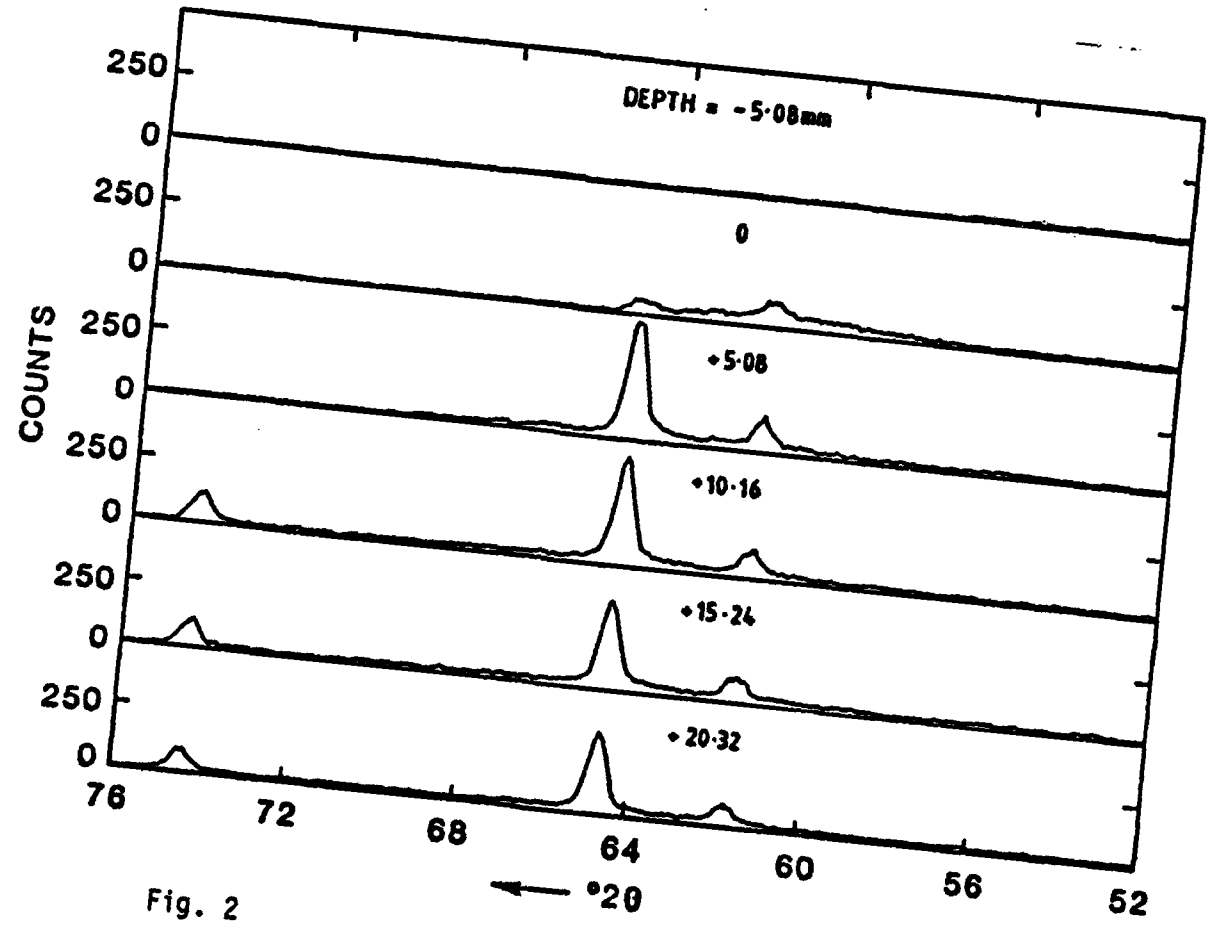
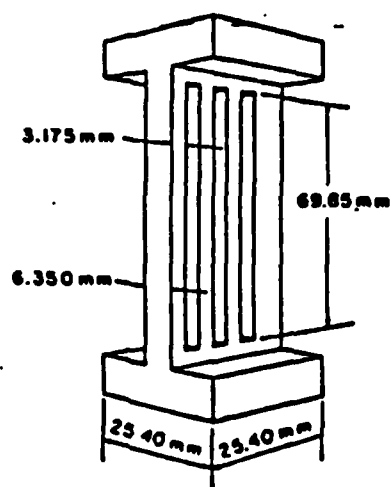
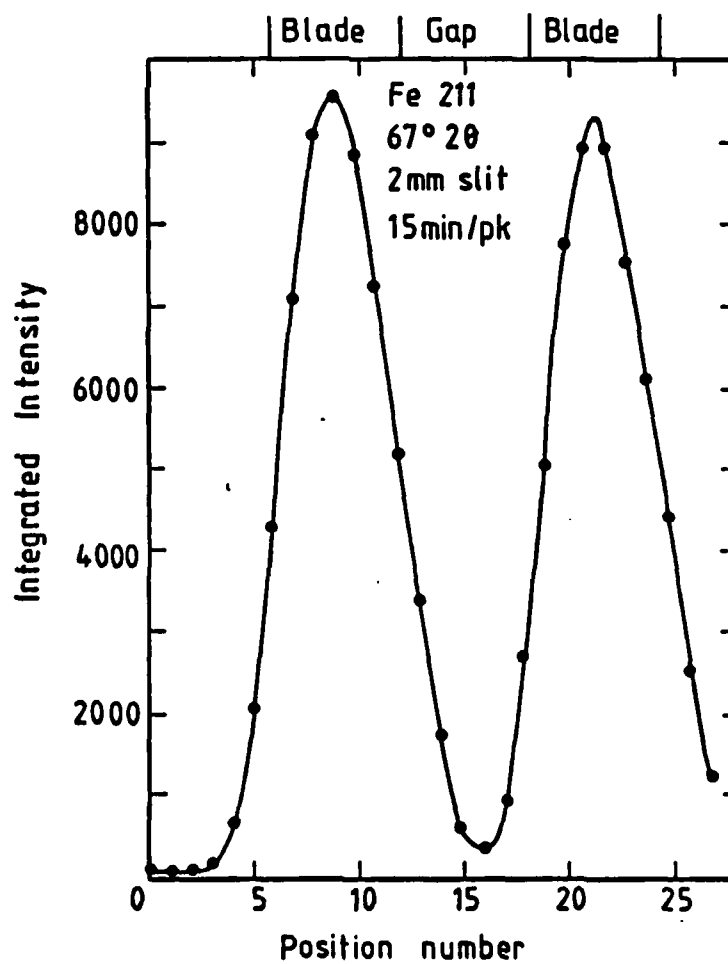

Fig. 2

(c)



(a)



(b)  
Fig. 3

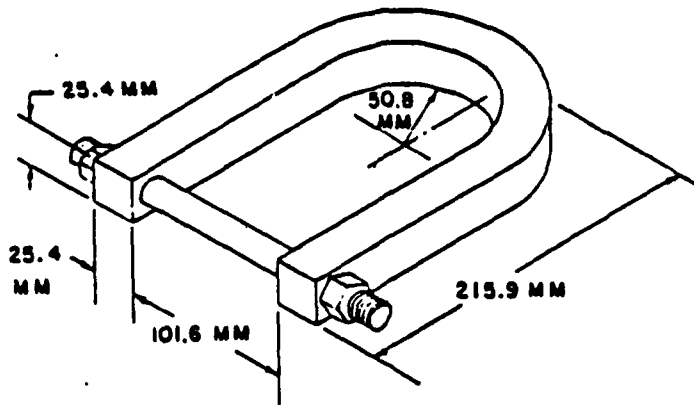

(a)

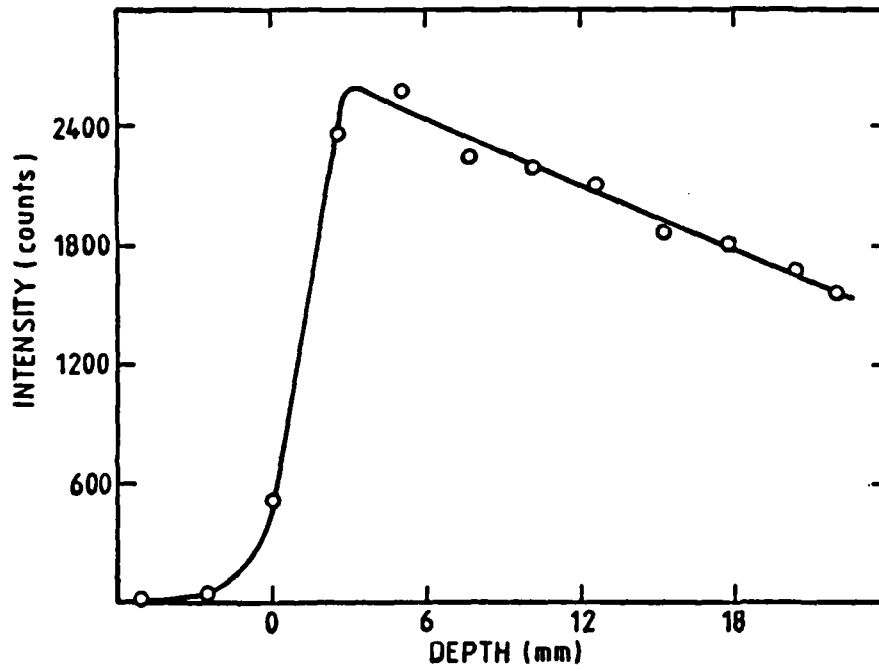

(b)

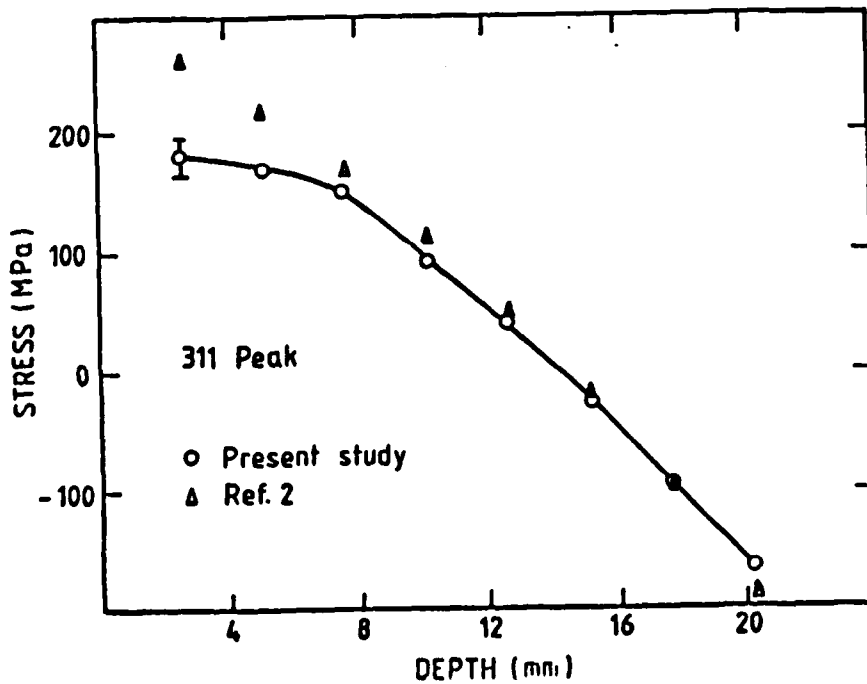
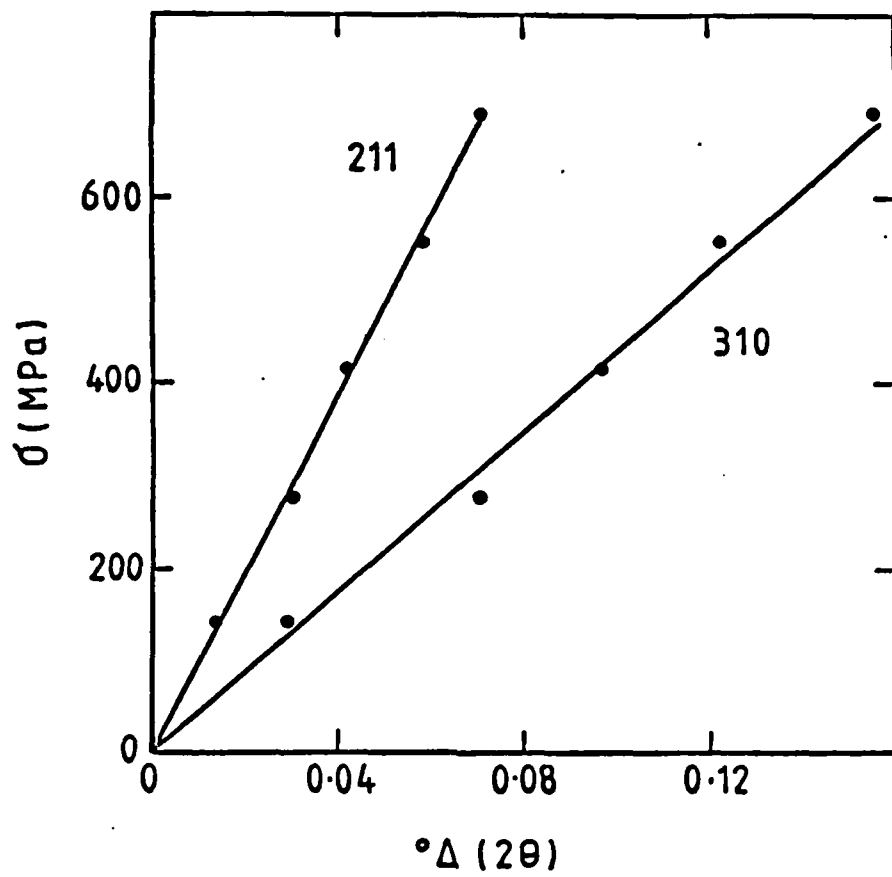
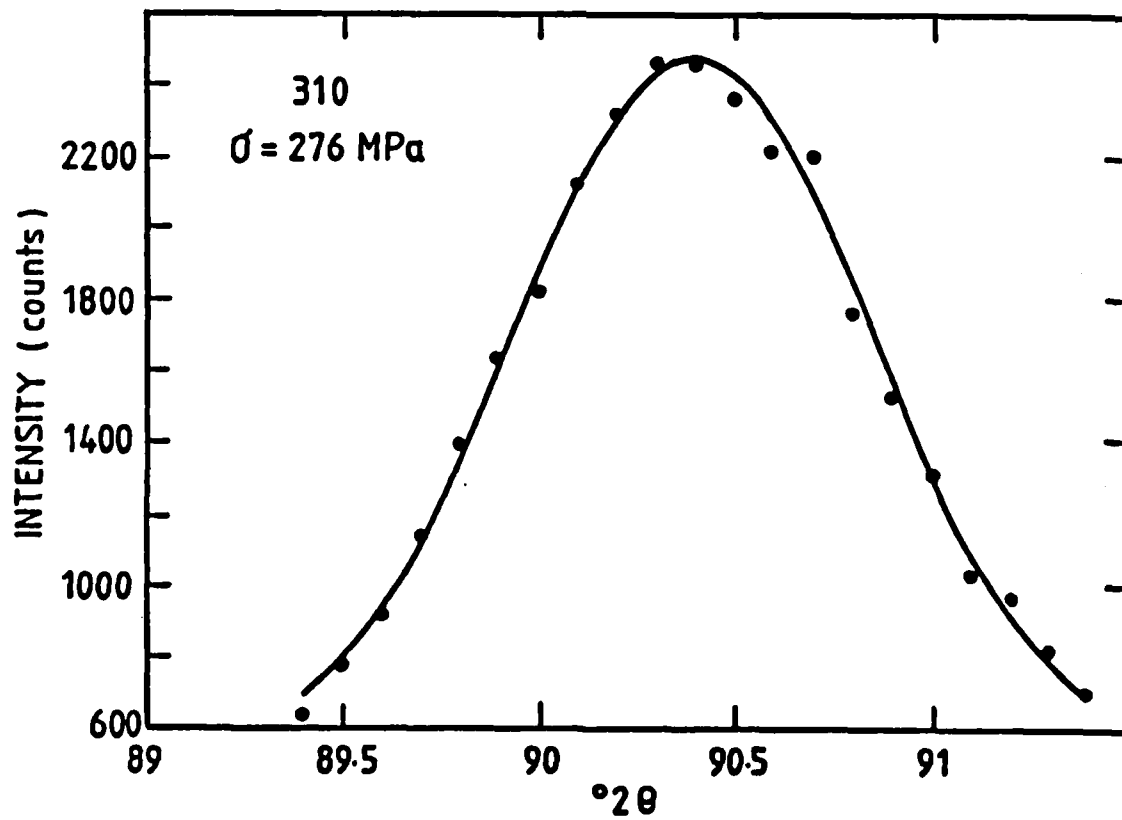

Fig. 4



(a)



(b)

Fig. 5

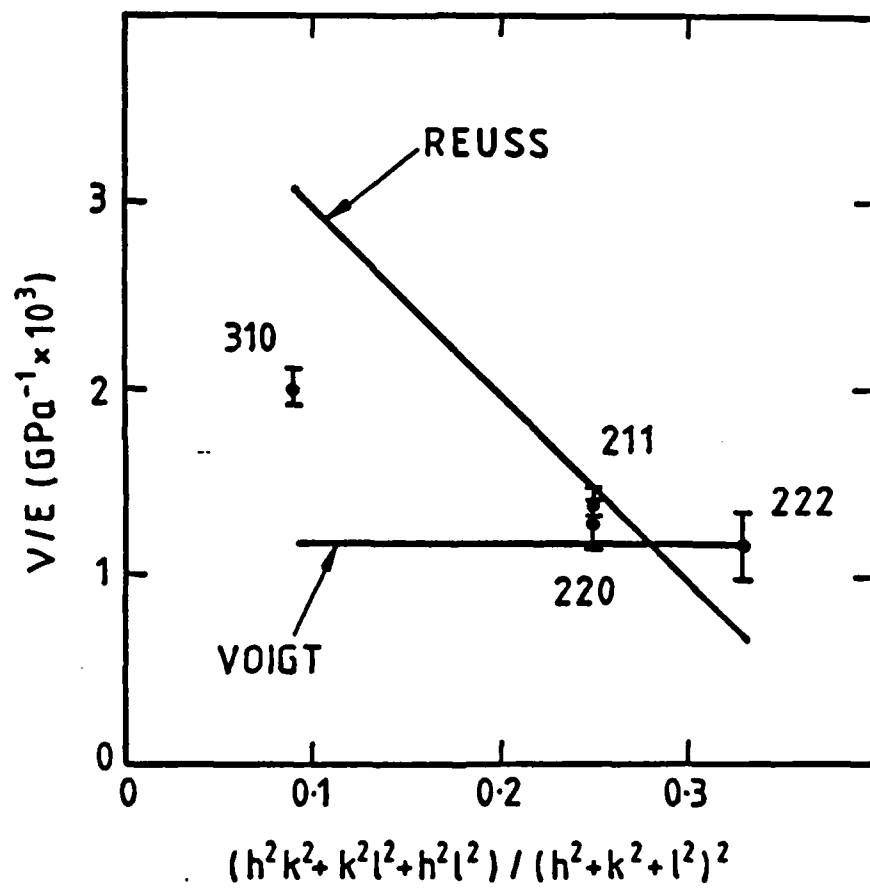

Fig. 6

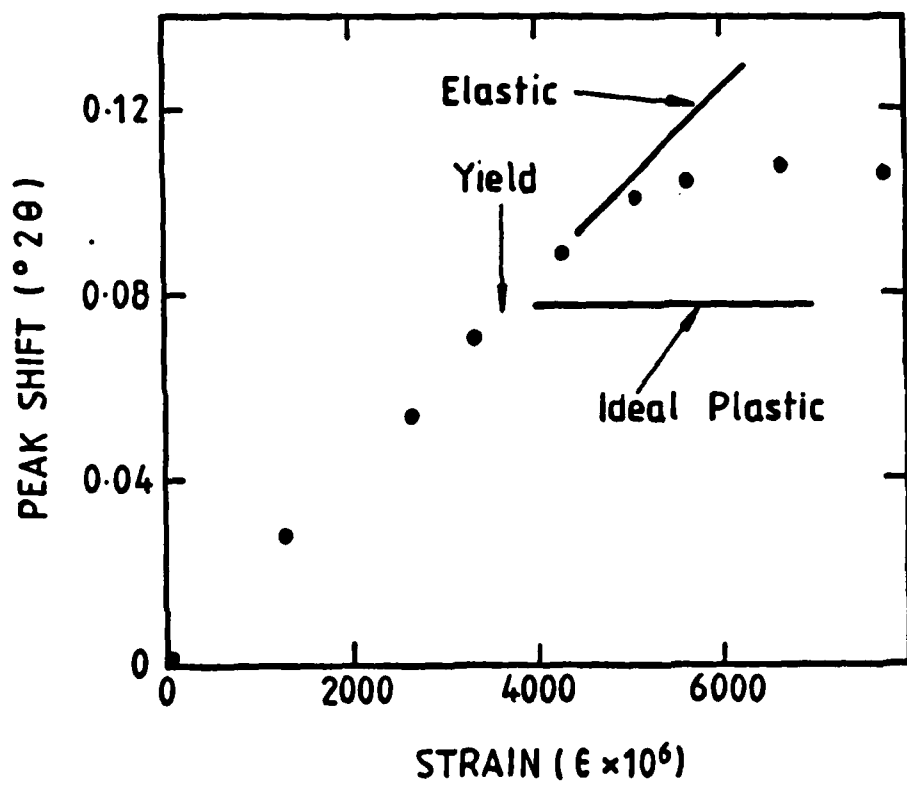

Fig. 7

A158882

Security Classification

DOCUMENT CONTROL DATA - R & D

(Security classification of title, body of abstract and indexing annotation must be entered when the overall report is classified)

1. ORIGINATING ACTIVITY (Corporate author) J. B. Cohen Northwestern University Evanston, IL 60201	2a. REPORT SECURITY CLASSIFICATION
	2b. GROUP

3. REPORT TITLE  
**NEUTRON STRESS MEASUREMENTS WITH A POSITION SENSITIVE DETECTOR**

4. DESCRIPTIVE NOTES (Type of report and inclusive dates)  
**TECHNICAL REPORT #20**

5. AUTHOR(S) (First name, middle initial, last name)  
**A. D. Krawitz, P. J. Rudnik, B. D. Butler and J. B. Cohen**

6. REPORT DATE <b>August 1985</b>	7a. TOTAL NO. OF PAGES <b>12</b>	7b. NO. OF REFS
--------------------------------------	-------------------------------------	-----------------

8a. CONTRACT OR GRANT NO. <b>N00014-80-C-116</b>  b. PROJECT NO.  c.  d.	9a. ORIGINATOR'S REPORT NUMBER(S)  <b>20</b>
	9b. OTHER REPORT NO(S) (Any other numbers that may be assigned this report)

10. DISTRIBUTION STATEMENT  
**Distribution of document is unlimited**

11. SUPPLEMENTARY NOTES	12. SPONSORING MILITARY ACTIVITY <b>Metallurgy Branch Office of Naval Research</b>
-------------------------	---

13. ABSTRACT  
  
The use of a position sensitive detector is demonstrated for measurements of residual stresses with neutrons. Small volumes may be explored in reasonable times of several minutes to one hour.

14.

KEY WORDS

LINK A

LINK B

LINK C

ROLE

WT

ROLE

WT

ROLE

WT

Residual stresses,  
Neutron diffraction  
Neutron measurements of residual stresses

**END**

**FILMED**

**10-85**

**DTIC**