

20000814137

2

SE

AD-A158 890

(Entered)

PAGE

READ INSTRUCTIONS  
BEFORE COMPLETING FORM

2. GOVT ACCESSION NO.

3. RECIPIENT'S CATALOG NUMBER

4. TITLE (and Subtitle)

Design of Composite Material Chambers  
for Solid Propellant Missile Motors

5. TYPE OF REPORT & PERIOD COVERED

Technical Paper, Aug. 1985

6. PERFORMING ORG. REPORT NUMBER

7. AUTHOR(s)

James LeRoy Szatkowski

8. CONTRACT OR GRANT NUMBER(s)

9. PERFORMING ORGANIZATION NAME AND ADDRESS

Naval Plant Branch Representatives Office  
P.O. Box 157, Magna, UT 34044-0157

10. PROGRAM ELEMENT, PROJECT, TASK  
AREA & WORK UNIT NUMBERS

11. CONTROLLING OFFICE NAME AND ADDRESS

Naval Plant Branch Representatives Office  
P.O. Box 157, Magna, UT 34044-0157

12. REPORT DATE

AUG 1985

13. NUMBER OF PAGES

20

14. MONITORING AGENCY NAME & ADDRESS (if different from Controlling Office)

15. SECURITY CLASS. (of this report)

UNCLASSIFIED

15a. DECLASSIFICATION/DOWNGRADING  
SCHEDULE

16. DISTRIBUTION STATEMENT (of this Report)

Approved for Public Release, Distribution Unlimited

17. DISTRIBUTION STATEMENT (of the abstract entered in Block 20, if different from Report)

DTIC  
ELECTED  
SEP 09 1985  
S  
D  
E

18. SUPPLEMENTARY NOTES

19. KEY WORDS (Continue on reverse side if necessary and identify by block number)

Composite material, missile chambers, composite pressure vessels,  
material properties, laminate analysis.

DTIC FILE COPY

20. ABSTRACT (Continue on reverse side if necessary and identify by block number)

A review of the technical research on composite materials  
used in the manufacture of solid propellant missiles has been  
conducted. Current design methods were compared to the methods  
given in the literature. Most of the designers of composite  
structures use empirical relationships based on data compiled  
from previous designs, to predict the structure's characteris-

DD FORM 1473 1 JAN 79

EDITION OF 1 NOV 68 IS OBSOLETE

S/N 0107-LP-014-6401

UNCLASSIFIED

SECURITY CLASSIFICATION OF THIS PAGE (When Data Entered)

85 09 03 092

tics. No universal approach to characterization of material properties of composites has been found, because no one has been able to adequately characterize the material properties of the constituent materials and their interrelationships. Recent analyses have shown that only finite element analysis (FEA) can adequately represent the material loading within the composite matrix. Accurate material properties, obtained only by detailed analysis of experimental work, are required to be used in the calculations. The properties are deduced from the experimental results by computer analysis by finite elements. Accurate analysis of the total structure of a composite material chamber will also require the use of 3-dimensional FEA. The use of 3-D FE has been limited because of computer time and costs. However, new computers will now handle reasonably sized 3-dimensional problems within acceptable limits of time and cost.

Accession For	
NTIS GRA&I	<input checked="" type="checkbox"/>
DTIC TAB	<input type="checkbox"/>
Unannounced	<input type="checkbox"/>
Justification	
By _____	
Distribution/	
Availability Codes	
Dist	Avail and/or Special
A-1	



**DESIGN OF COMPOSITE MATERIAL CHAMBERS  
FOR SOLID PROPELLANT MISSILE MOTORS**

by

**James L. Szatkowski, PE  
B.S.E.E., University of Utah, 1976  
M.S.M.E., Naval Postgraduate School, 1984**

**85 09 03 092**

## ABSTRACT

← A review of the technical research on composite materials used in the manufacture of solid propellant missiles ~~has been~~ conducted. Current design methods were compared to the methods given in the literature. Most of the designers of composite structures use empirical relationships based on data compiled from previous designs, to predict the structure's characteristics. No universal approach to characterization of material properties of composites has been found, because no one has been able to adequately characterize the material properties of the constituent materials and their interrelationships. Recent analyses have shown that only finite element analysis (FEA) can adequately represent the material loading within the composite matrix. Accurate material properties, obtained only by detailed analysis of experimental work, are required to be used in the calculations. The properties are deduced from the experimental results by computer analysis by finite elements. Accurate analysis of the total structure of a composite material chamber will also require the use of 3-dimensional FEA. The use of 3-D FE has been limited because of computer time and costs. However, new computers will now handle reasonably sized 3-dimensional problems within acceptable limits of time and cost. ←

## TABLE OF CONTENTS

Abstract	1
Table of Contents	ii
Nomenclature	iii
Introduction	1
Theoretical Development/Literature Review	2
Current Applications	7
Conclusions/Recommendations	10
Appendix 1	12
Appendix 2	14
List of References	18

## NOMENCLATURE

E	Young's modulus
G	Shear Modulus
K	stress concentration factor
M	moment
P	pressure
x,y,z	principle directions, cartesian coordinates
r, $\theta$	principle directions, polar coordinates
V	volume
W	weight
$\sigma$	stress, normal
$\tau$	stress, shear
$\epsilon$	strain
$\theta$	angular displacement, in degrees
$\nu$	Poisson's ratio

## INTRODUCTION

Composite materials have been used for solid rocket motor applications for almost three decades. The development of these materials progressed at a rate significantly ahead of the basic theoretical analysis, so a trial and error development program was the foundation for years of manufacturing. The design parameters of isotropic materials are highly developed, and data on the material properties, including most failure properties, are readily available. However, no similar information is available for composite materials. Designers must rely on the meager collection of data that has been compiled from experimental programs with similar designs and composite structures.

Significant work has been performed in the development programs of rocket chambers, to test and evaluate sub-scale pressure vessels of similar design and composite structure. These sub-scale results are then scaled-up to the design requirements. Unfortunately, the scaling factors are not well understood and failures often occur; this is primarily the result of the lack of fundamental knowledge of the composite structures material interactions.

Study has been devoted to this fundamental deficiency. Researchers have attempted to apply basic isotropic material relationships to specific composite structures and have had limited success in the determination of the characteristics. Isotropic materials such as metals, crystals and some plastics, are not purely isotropic; their failure properties account for the irregularities and characterize the failure mode(s) that result according to the size, location and orientation of these irregularities. Since composite materials are, by their very nature, anisotropic, the attempt to characterize their material properties with relationships that relate the defects in their structure to their strength and failure modes is misguided.

In this paper I will survey the theoretical development of composite structures and contrast the theory with the current manufacturing design practices. I will discuss the proofing methods and those methods that are used to analyze damage to pressure vessels. Conclusions and recommendations will be offered to improve the design and analysis methods used in current chamber design and structural analyses.

## THEORETICAL DEVELOPMENT/LITERATURE REVIEW

### Laminate Theory (LT)

The general laminate theory is a mathematical means of calculating the material properties of a composite from the angles of fiber orientation and the properties of the layers of the fibers. The matrix properties are included in this calculation and the matrix is assumed to be homogeneous and perfectly bonded to the fibers. The elastic properties of the layers are determined from the Young's moduli  $E_{11}$ ,  $E_{12}$ , the shear modulus  $G_{12}$ , and the Poisson's ratio  $\nu_{12}$  using Hooke's-law relationship:

$$\sigma = E\epsilon, \quad \text{Eqn. 1}$$

where strain is proportional to stress.

The laminate properties are calculated by using the angle of the laminate direction and the angle of the material, which are then added vectorially (see Appendix 1).

Theory implies that the stacking sequence and boundaries will have no effect on laminate strength. Pagano and Pipes [1] have shown that this is not true. Their work illustrated significant stacking sequence effects, as well as significant boundary effects. Tolbert [2] also reported that the laminate theory failed in the analysis of thick-walled cylinders, but was able to represent thin-walled vessels without serious error. The primary fault of this theory is in its assumption of zero boundary stress fields. It seems to accurately account for the stress fields remote from the boundary layers.

Many researchers have attempted to confirm this theoretical development; however, there has been little success in correlating the experimental results to the theory. The assumptions made to simplify the calculations do not allow for the physical defects in a manufactured laminate structure of a thickness greater than one-tenth of an inch [3].

For rough calculations, the general laminate theory can be used to obtain the approximate laminate strength; the result can be refined by experimental trial and error procedures. Chamis [4] published a procedure, based on laminate theory, that can be adapted for use on small computers or hand-held calculators.

The relationships that apply to material properties are not affected by thickness and are discussed in the theory of applied mechanics. Fracture mechanics change with specimen thickness. Fracture mechanics theory is highly developed for isotropic materials, but not for anisotropic laminate structures. Further,

the relationships between the fracture characteristics of thick and thin fiber-reinforced laminates have not been established.

### Linear Elastic Fracture Mechanics (LEFM)

Several investigators have modified LEFM for a homogeneous anisotropic material (see Appendix 2). They have developed expressions for the crack tip stress field, using Hooke's law, for a homogeneous linear anisotropic material in the case of plane strain and pure shear. The results were analogous to the isotropic material case. The results for non-homogeneous anisotropic laminates were different, but were characterized by the "inherent flaw model". In this model, a "high intensity energy region" adjacent to the holes and at the tip of the notches was postulated. This region was assigned a dimension which was then used in the plastic zone correction factor for isotropic materials to modify the stress intensity factors and the stress distribution. The investigators found that single cracks do not nucleate and grow, as in metals, under fatigue loading. This leads to the question of how applicable LEFM is for composite materials.

While trying to explain this phenomenon and the characteristic problem, the investigators postulated a non-fracture mechanics stress fracture criteria. A "point stress model" postulated that failure would occur when the average stress at some distance from the discontinuity reached the critical stress. This model worked well with some laminates, and not so well with others.

Using the LEFM and the R-curve concept, which relates the rising fracture toughness of the material to the increasing crack extension, the size of the plastic zone for conventional materials of thin sheets may be considered. For fiber-reinforced thin sheets, the point and average stress models explain the increase in toughness as the notch length increases, as a result of the stress distribution near the notch tip. These approaches consider the deviation of the load/crack opening displacement curve from linearity because of the damage zone formation and self-similar crack extension. This does not apply in thick laminates or in laminates with delaminations [5].

Shih and Logsdon [6] found during their study of thick-section graphite/epoxy composites that the LEFM did not apply directly to the composites which had cracks perpendicular to the fiber orientation. They also found that in three-point bending the failure mode was interply failure. This mode of failure faults the basic assumptions in LEFM.

Self-similar crack-propagation, another assumption of the

homogeneous anisotropic model, is not assured because of the anisotropy and heterogeneity of the laminate microstructure. Only for fractures that are confined to interlaminar planes, where the matrix phase dominates the fracture response and where self-similar propagation is assured, can LEFM be used effectively [7]. In these cases, tests can determine the stress intensity factors,  $K_I$ ,  $K_{II}$ , and  $K_{III}$  for the opening, shearing and tearing modes, respectively, as well as the mixed mode of fracture.

Other researchers found that the values of toughness reached asymptotic values and nonhomogeneities because of fiber size and ply thickness were not significant. Simple macromechanical models based on LEFM, such as the boundary integral equation (BIE) method, could be employed to predict fractures.

Further models, such as the "shear-lag model", were developed to predict the behavior of unidirectional fiber-reinforced composites that were susceptible to matrix splitting ahead of the crack tip vs. fiber. This two-dimensional model assumes that the fibers support all the axial force (because of their higher elastic modulus) and the matrix supports the shear and transverse normal forces. This method can be modified for angle ply laminates also. The micromechanical models, such as the BIE and the "shear-lag" model, were generally more accurate in the fracture predictions than in the macromechanical models.

The macromechanical models which treat the composite as a homogeneous anisotropic medium do not fully explain the physical failure mechanism, even when they agree with the experimental results. The micromechanical models have the potential to account for the effects of material nonhomogeneity. These nonhomogeneities can be addressed by careful analysis with finite element methods [8].

## 2-Dimensional Finite Element

The finite element method of failure characterization assumes that when an individual finite element exhausts all of its capacity for strain energy, it fails, forming a crack. The element is then removed from the matrix; the reaction loads it had are transferred to the adjacent elements; its stiffness property is reduced to zero. If the reaction loads exceed the capacity of adjacent elements, they too fail. Should the applied stress on the composite remain constant during this process, catastrophic failure occurs. This model can be used to study the basic failure processes that take place in matrix material. The model can study post-debond sliding between fiber and matrix, fiber fracture, and fiber pullout, to mention a few of the many possibilities.

The full characterization of the failure of an inhomogeneous anisotropic laminate material is exceptionally complex. The planar characteristics have been formulated by Wang [9] whose model considers a partially closed delamination having frictionless crack-surface contact. The result is the classical inverse square-root singularity with an algebraic multiplicity of two. With frictional contact, the results depend on the frictional coefficients and the fiber orientations of the adjacent dissimilar plies. If the delamination has a very small area of crack closure, the model is simplified by taking the limit of the partially closed delamination. Wang used Lekhnitskii's complex-variable stress potentials in conjunction with an eigenfunction expansion method, which leads to a standard eigenvalue problem. From this eigenvalue problem, stress singularities and the general solution structures of deformation and stress fields associated with composite delamination are determined. The complexities of the composite delamination phenomenon include the inherent crack-tip singularity, the effect of anisotropy of each constituent fiber lamina, and the abrupt change of stiffness or ply orientation through the laminate thickness direction. In addition, the 3-dimensional state of stress and deformation that exists at the delamination gives rise to all modes of fracture, which renders the problem mathematically intractable.

For pressure vessels and large planar structures, it is not only convenient, but accurate to model these structures as 2-dimensional. This simplification allows accurate mathematical formulation and solution with finite element analysis and methods as advanced recently by Wang [10] and many other authors.

These analyses require the material properties to be accurate for the fracture conditions. This requirement will force the testing methods to accurately characterize the conditions in the composite, including the fiber-resin interaction and the resin properties in the laminate [11]. The resin properties in the laminate may differ significantly from test coupons because of processing variations and conditions that cannot be duplicated in a test coupon. There may be a significantly higher concentration of trapped air bubbles and airborne particles. The environmental conditions and winding variables, such as winding speed and tension, will affect the resin properties and, hence, the laminate properties.

### 3-dimensional Finite Element

In the structures where the stress state is not planar, and a true 3-dimensional stress state exists, the only accurate analysis of the fracture behavior is by 3-dimensional finite element. Although this method has been formulated for years, the mathematical difficulties, because of the sheer number of

calculations required, have precluded its effective use until recently. The structures of principal concern include aircraft structural members and pressure vessels that are not perfect spheres. Cylindrical pressure vessels have stress states that approach planar in the cylinder section, but have complicated 3-dimensional stress states in the dome end sections.

Wang [12] has solved the problem of composite delamination and failure using the theory of anisotropic laminate elasticity and interlaminar fracture mechanics. These solutions require the use of 3-dimensional finite element analysis to accommodate the 3-dimensional stress state and interactions of the laminate materials. This problem is very complex because of the geometric and material discontinuities and the inherently coupled modes of fracture. Wang presents the effects of the geometry, the lamination and the crack variables. The basic governing equations are lengthy and complex and are well presented in [12], so I omit them here. His results do show that the stress intensity factor for the tearing mode is one or two orders of magnitude higher than the other modes. Wang also confirmed that the fiber orientations, ply thickness, stacking sequences and other lamination variables all effect the delamination behavior significantly.

A more efficient, cost-effective finite element method was developed based on the concept of the mode III magnitude by Nishioka and Altluri [13]. This was a one-step, smaller mesh refinement of their hybrid 3-dimensional method that used a two-step solution with a very fine mesh.

### Design Effects

The sequence of the stacking of the fiber layers has a significant effect on the strength of the composite [1,10]. Herakovich discussed the theoretical implications of the stacking sequence through the theories analyzed by finite element methods [14]. The use of adjacent  $\pm \theta$  layers leads to high interlaminar shear stresses and that interlaminar normal stresses are very dependent on the stacking sequence. Therefore, adjacent  $\pm \theta$  layers should generally be avoided. Interspersed  $\pm \theta$  layers are preferred to reduce the extremes of interlaminar shear and normal stresses. This is because of a "mismatch" of the engineering properties between adjacent layers. The interlaminar shear stresses are a function of the coefficients of mutual influence that can be ten times greater than the mismatch of Poisson's ratio. This mismatch reaches a peak at  $10^\circ - 15^\circ$  fiber range for  $\pm \theta$  laminae combinations. It can be reduced by a factor of two when the layers are interspersed between  $0^\circ$  and  $90^\circ$  layers.

Layer thickness, both total and resin/fiber ply, affects the

laminates structural characteristics. Apart from the obvious linear effect of multiple plies of specific strength, the composite's fracture and failure characteristics are altered with variations in thickness. The stacking sequence of the plies also effects the overall thickness; a clustered sequence of plies can be twice as thick as an alternated sequence as shown in Figure 1. Although the in-plane elastic properties of such laminates are independent of stacking sequence, the strength and toughness can vary significantly [15].

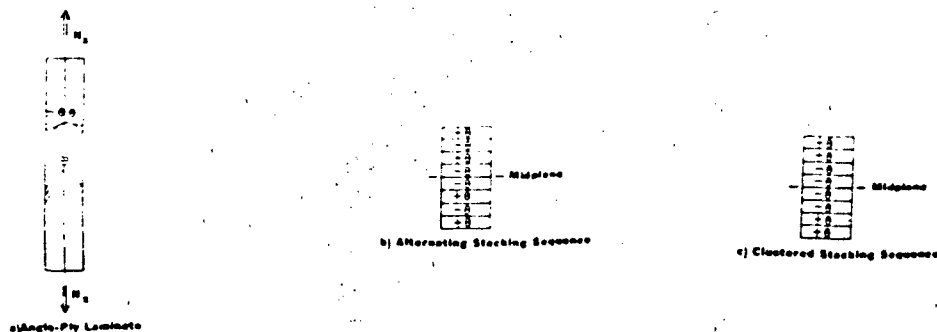

### Stacking Sequence and Fiber Orientation

Figure 1.

Resin systems are formulated to provide specific matrix properties, processing characteristics and fiber/resin bonds. These resins must have chemical characteristics that are compatible with the fiber(s) being used in the composite. Damage tolerance of a composite structure is a function of the resin volume content and the plastic flow characteristics of the resin. This resin also effects the compressive strength of the composite. The failure mode frequently observed is a delamination fracture in the through thickness direction. Therefore, improving the compressive strength of the resin/fiber system should improve the damage tolerance of the composite. Resin systems with elastomeric additives, thermoplastic additives and vinyl modifiers have shown improved tolerance to damage [16]. The interlaminar shear strength of the composite is dependent on the fiber-resin bond; fiber surface treatment may improve the composite's characteristics [17].

### CURRENT APPLICATIONS

The designers of the chambers for modern solid rocket motors use many methods. The designer is given the parameters and allowables for a feasible design based on previous data and expected gains through new materials and/or approaches. The

structural members of the design are chosen to balance reliability and performance. The reliability is calculated by the expected number of failures under normal operating conditions. The performance of missile chambers is calculated from the product of the pressure inside the chamber and the volume of the chamber divided by the weight of the chamber and is represented by:

$$\text{Performance} = P_r V/W$$

Eqn.2

The theories that are applied to the requirements are in two categories: thin-wall and thick-wall. The typical missile chamber is in the thin-wall category, whereas the segments for the filament-wound chambers used in the solid rocket motors for the Space Shuttle Program are in the thick-wall category. The exact transition point between the two criteria has not been fully characterized.

With these limitations, the designer calculates the loads the chamber will experience and, after applying appropriate margins of safety for the reliability criterion, designs the required composite structure. He typically predicts the expected fiber stresses by extrapolating those that were experienced in previous designs similar to the one in development.

From the data that he has access to on other similar designs, the designer derives material properties. The structural testing of design prototypes during development is crucial. An initial design is then formulated by combining netting theory, a winding model, and dome-contour empirical equations. These contour equations are varied through several dome designs to obtain a design that meets the design criteria. Two-dimensional finite element analysis is applied to locate the hoop reversal points, to size port reinforcements, and to determine the hardware geometries. These finite element codes may be separated for the forward and after dome regions, if they are different by virtue of the asymmetry of the chamber. This separation may significantly reduce the computer time required to process the model. The separation is made at a point on the chamber where the loading is purely, or nearly so, membrane load. The 2-D finite element analysis provides the designer with the displacements, strains, and stresses for the loading of the fiber matrix analysis.

Safety factors and margins of safety are applied in accordance with the MIL Handbook V Interaction Equation based on the worst-case set of peak loads. The skirts are designed for the chamber after the initial design of the pressure vessel. The skirts provide for the structural transmission of the boost energy, as well as providing the handling and attaching fixture for the pressure vessel. The skirts are designed to resist buckling in all modes including: bending, differential pressure,

axial loading and shear.

Tests are required to adjust empirical and semi-empirical formulas and relationships which will account for designs & test results that differ from the previously used values.

These adjustments usually account for the differences in material testing properties from standard tensile and coupon tests and allow for the composite material interaction. Although these adjustments would allow for the back-calculation of material properties as they apply in the composite structure, the relationships are usually adjusted instead. The adjusted relationships become very effective for the design in consideration and can result in actual performance at failure being within a few percent of predictions.

This empiricism is an acceptable and prudent method of design for those applications that closely resemble in structure, or composition, a previous design with a given data base. For radical designs or composite structures, the empiricism would be as costly as developing the theory to the application.

Three-dimensional analysis is used when other methods fail to account for an anomalous condition or a failure that cannot be explained with existing analysis. The software and engineering is available to make this a routine evolution and the basis for most design evaluations.

Current testing procedures include the instrumentation of chambers, real-time and standard radiography, structural loading, and the hydro-proofing and hydro-bursting of chambers. The proof testing of composite materials was studied by Hahn and Hwang [18]. The lifetime and strength of most materials usually show more scatter than the other material properties, since they are related to local defects in the homogeneous structure. In the composite structures, lifetime is related to static strength. The effect of proof testing on subsequent strength has been found to be negligible. The actual amount of proof stress that can be endured has not been exactly characterized, although no apparent reduction in strength has been noted in vessels tested through the design loads.

Materials for the composite structures are constantly in review. Current experimental work in this field is attempting to increase the performance of composite pressure chambers on the order of 15-25%. Laboratory testing of new fibers, resins and fiber/resin systems has had promising results [19]. These results represent tests with small pressure bottles which have been standardized in dimensions for compilation of data. The results would then be scaled to a future design using existing methods.

## CONCLUSIONS AND RECOMMENDATIONS

The current level of theoretical development of composite chambers is well beyond the practical application level used in the design and manufacture of these chambers. The most promising area of fundamental growth that can be applied to the designing and manufacturing areas is that of accurate 3-dimensional finite element analysis (3-DFE). The limiting factors precluding this transition include:

1) The reluctance of industry to adapt hardware and software to perform these analyses.

2) The lack of expertise at the industry level to effectively employ the procedures of this method, including the selection of the regions where 3-DFE analysis is required.

3) The lack of testing methods and systems to determine the material properties within the composite structure by deduction through 3-DFE methods; e.g. the deduction of the material properties from test results instead of vice versa.

The longitudinal material property values that are compiled in the literature are not very useful in the designs; actual designs include many property-reducing factors such as stress concentrations, fiber wash, fiber slipping, resin-rich and resin-lean regions, delaminations and voids. These factors, although not part of the design, exist in all manufactured chambers to some degree. The analyses of the current designs are based on the data from previous tests and have empirically included these effects on a macroscopic scale. This then does include the "unknowns". The problem often arises where some damage or a manufacturing defect beyond those that are inherent occurs and an analysis is required to determine the suitability of the chamber for use. This analysis, if limited to two-dimensions, may miss a critical stress condition in the triaxial condition that actually exists.

Because of the multiplicity of possible failure modes, the prediction of the ultimate failure strength is very difficult from the theory. The original designs have built-in factors of safety and empirical factors regarding the actual test data of similar designs. These factors cannot be directly applied to the theoretical optimization calculations. Fundamental data will have to be obtained in order to reach an optimum design condition. Critical design optimizations can utilize successive approximations to create the proper angles of windings, dome contours and fiber layers, as well as resin content. The routines to accomplish this can be created with significant pay-back on the investment by providing designs that approach the maximum possible performance and reliability with given materials.

I recommend that current designers adapt the testing and design methods that utilize 3-DFE as their foundation. The hardware and software required to accomplish this exists. The costs are justifiable. Software to do limited 3-DFE is currently available for PC's that can be on the designer's desktop. More advanced CAD routines incorporate 3-dimensional graphics that can display the grids and visually display the stresses that a design is experiencing to the designer/engineer. These tools for design exist and should be incorporated into our current design/evaluation techniques.

## APPENDIX 1

General Notes on Laminate Theory from "Composite Materials Handbook"-Mel M. Schwartz, McGraw-Hill

Laminate analysis is a mathematical means of determining elastic properties of the complete laminate from the angles of fiber orientation and elastic moduli of the individual layers. Conversely, the method is also used to determine stress and strains in each layer produced by stretching and bending forces on the complete laminate.

The elastic properties of a laminate ( $E_x, E_y, G_{xy}, \nu_{xy}$ ) are determined in three steps:

1) The elastic properties of each layer are determined from the moduli  $E_{11}, E_{12},$  and  $G_{12}$  and Poisson ratio  $\nu_{12}$  of the layer material. These properties are determined from the Hooke's-law relationship between stress and strain in the principal material directions (parallel and perpendicular to the fiber direction).

2) The elastic properties of each layer in the principal laminate directions (parallel and perpendicular to the axis of the laminate structure) are determined from the material-direction properties and the angle between the laminate and the material directions.

3) A summation of the laminate-direction elastic properties of all layers, taking into account their relative positions with respect to the midplane of the complete laminate, yields the elastic properties of the complete laminate (Fig. 2).

Laminate analysis is also used to determine stresses and strains in each layer due to forces on the laminate. Layer strains are determined from laminate strains and rotations, taking into account the layer position relative to the middle surface of the complete laminate. Stresses in each layer are then determined from layer strains and the Hooke's-law relationship. Thus, the stresses and strains at a point in the structure can be calculated in every direction, that is,  $\sigma_x, \sigma_y, \tau_{xy}$  and  $\sigma_{11}, \sigma_{22}, \tau_{12}$  in every ply.

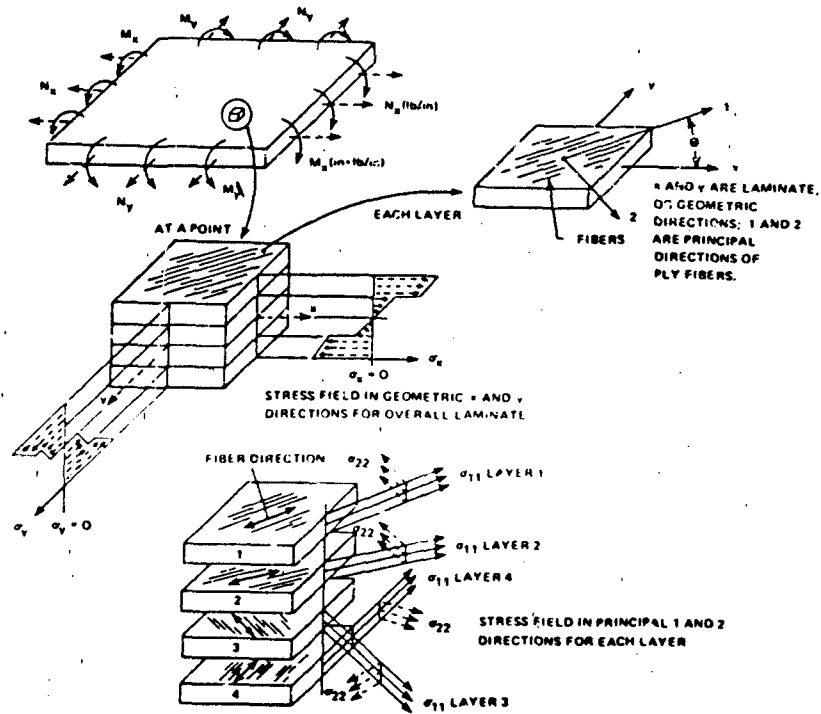

General Laminate Structure, with Loads

Figure 2.

## APPENDIX 2

General Notes on Linear Elastic Fracture Mechanics (LEFM) Theory from "Fracture Toughness Testing and Its Applications-Symposium on Fracture Toughness Testing and Its Applications, ASTM Special Technical Publication No. 381, American Society For Testing and Materials, 1964

The introduction of stresses in a body, caused by a crack, is a feature of the strength of the material. The stresses near the crack tip may result in the growth, or perpetration of the crack or flaw. The nonlinear and plastic effects are neglected in the gross features discussed in this presentation, but may be significant in a given scenario. The stress-field expansions for the crack tips are applicable for the general case of an isotropic elastic body. The three modes, opening, edge-sliding and tearing, (I,II and III respectively) are shown in the figure (3).

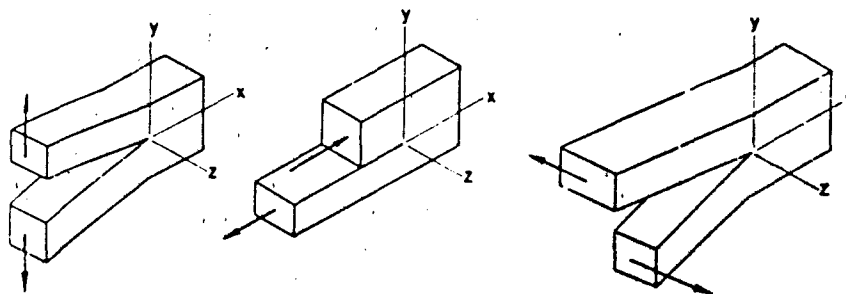

The Basic Modes of Crack Surface Displacements.  
Figure (3).

The surfaces of a crack dominate the distribution of stresses in the vicinity of the crack. Other boundaries are remote and affect only the intensity of the local stress field, as does the loading forces applied to the body. The opening mode, I, is associated with the local displacement where the crack surfaces move directly apart. The edge sliding mode, II, is where the displacements move over one another, perpendicular to the leading edge of the crack. The tearing mode, III, is where the crack surfaces slide parallel to the leading edge of the crack.

Modes I and II can be treated as plane-extensional problems in the theory of elasticity, symmetric and skew-symmetric, respectively. Mode III is a pure torsion or shear problem. Using the notation in figure (4), the resulting stress and displacement fields are derived:

Mode I.

$$\sigma_x = (K_I / (2\pi r)^{1/2}) \cos(\theta/2) [1 - \sin(\theta/2) \sin(3\theta/2)]$$

$$\sigma_y = (K_I / (2\pi r)^{1/2}) \cos(\theta/2) [1 + \sin(\theta/2) \sin(3\theta/2)]$$

$$\tau_{xy} = (K_I / (2\pi r)^{1/2}) \sin(\theta/2) \cos(\theta/2) \cos(3\theta/2)$$

$$\sigma_z = \nu(\sigma_x + \sigma_y), \quad \tau_{xy} = \tau_{yz} = 0$$

$$u = (K_I / G) [r / (2\pi)]^{1/2} \cos(\theta/2) * \\ [1 - 2\nu + \sin^2(\theta/2)] \\ = (K_I / G) [r / (2\pi)]^{1/2} \sin(\theta/2) * \\ [2 - 2\nu - \cos^2(\theta/2)]$$

$$w = 0.$$

Mode II:

$$\sigma_x = -[K_{II} / (2\pi r)^{1/2}] \sin(\theta/2) [2 + \cos(\theta/2) \cos(3\theta/2)]$$

$$\sigma_y = [K_{II} / (2\pi r)^{1/2}] \sin(\theta/2) \cos(\theta/2) \cos(3\theta/2)$$

$$\tau_{xy} = [K_{II} / (2\pi r)^{1/2}] \cos(\theta/2) [1 - \sin(\theta/2) \cos(3\theta/2)]$$

$$\sigma_z = \nu(\sigma_x + \sigma_y), \quad \tau_{xz} = \tau_{yz} = 0$$

$$u = (K_{II} / G) [r / (2\pi)]^{1/2} \sin(\theta/2) * \\ [2 - 2\nu + \cos^2(\theta/2)]$$

$$v = (K_{II} / G) [r / (2\pi)]^{1/2} \cos(\theta/2) * \\ [-1 + 2\nu + \sin^2(\theta/2)]$$

$$w = 0.$$

Mode III:

$$\tau_{xz} = -(K_{III} / (2\pi r)^{1/2}) \sin(\theta/2)$$

$$\tau_{yz} = (K_{III} / (2\pi r)^{1/2}) \cos(\theta/2)$$

$$\sigma_x = \sigma_y = \sigma_z = \tau_{xy} = 0$$

$$w = (K_{III} / G) [(2r) / \pi]^{1/2} \sin(\theta/2)$$

$$u = v = 0.$$

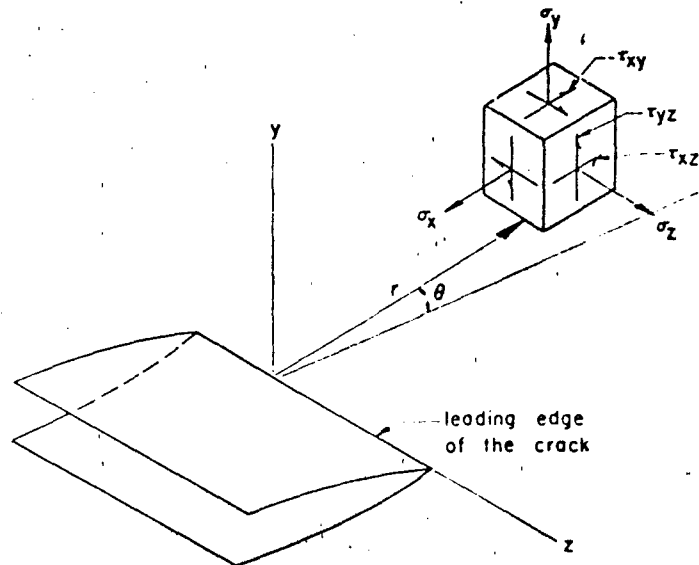

Coordinates of the Stress Components in the Crack Tip.  
Figure (4).

The parameters,  $K_I$ ,  $K_{II}$ , and  $K_{III}$  in the equations are stress-intensity factors for the corresponding three types of stress and displacement fields. These factors must contain the loading force magnitudes linearly (for linear elastic bodies) and depend on the configuration of the body including the crack size. They, therefore, reflect the redistribution of stress in a body due to the introduction of a crack and the force transmission through the crack tip.

It has been shown that, for the general homogeneous anisotropic case, the crack-tip stress fields and their intensity factors, the complete analogy with the isotropic case is preserved. By judicious definition of the anisotropic stress-intensity factors, they are identical to those for the isotropic case. However, for the non-homogeneous anisotropy, the resultant stress fields and intensity factors, as well as stress distributions, may well be different and result in different singularities than those observed in the homogeneous case.

The introduction of viscoelasticity into the problem results in similar intensity factors and stress distributions in the vicinity of cracks; however, this causes these factors to now become variables as a function of time.

The complete discussion and development, as well as extensions to other and general cases is found in the above credited text and this presentation is merely a condensation of the

principle governing equations. It is given for completeness and the readers reference.

## REFERENCES

1. Pagano, N.J. and Pipes, R.B., "The Influence of Stacking Sequence on Laminate Strength," Journal of Composite Materials, vol. 5, Jan. 1971, pp. 51-57
2. Tolbert, R.N., "Stiffness Properties for Dynamic Modeling of Composite Graphite-Epoxy Cylindrical Orthotropic Shells," NASA CR-170942, Dec. 1983
3. Harris, C.E. and Morris, D.H., "Fracture Behavior of Thick, Laminated Graphite/Epoxy Composites," NASA CR-3784, 1984
4. Chamis, C.C., "Prediction of Fiber Composite Mechanical Behavior Made Simple," NASA TM-81404, Feb. 1980
5. Peters, P.M.W., "On the increasing fracture toughness at increasing notch length of 0/90 and 0/+45/0 graphite/epoxy laminates," Composites, vol. 14, Oct. 1983, pp. 365-369
6. Shih, T.T. and Logsdon, W.A., "Fracture Behavior of a Thick-Section Graphite/Epoxy Composite," Fracture Mechanics: Thirteenth Conference, ASTM STP-743, 1981, pp. 316-337
7. Jurf, R.A. and Pipes, R.B., "Interlaminar Fracture of Composite Materials," Journal of Composite Materials, vol. 16, Sept. 1982, pp. 386-394
8. Mahishi, J.M. and Adams, D.F., "Fracture Behaviour of a Singlefibre Graphite/Epoxy Model Composite Containing a Broken Fibre or Cracked Matrix," Journal of Materials Science, vol. 18, 1983, pp. 447-456
9. Wang, S.S., "The Mechanics of Delamination in Fiber-Reinforced Composite Materials, Part I - Stress Singularities and Solution Structure," Mechanics of Composite Materials-1983, Proc. of the Winter Annual Meeting of Mechanical Engineers, ASME AMD-Vol. 58, pp. 83-104
10. Wang, S.S., "The Mechanics of Delamination in Fiber-Reinforced Composite Materials, Part II - The Delamination Behavior and Fracture Mechanics Parameters," Mechanics of Composite Materials 1983, Proc. of the Winter Annual Meeting of Mechanical Engineers, ASME AMD-Vol. 58, pp. 105-133
11. Marloff, R.H., "Finite Element Analysis of Biaxial Stress Test Specimen for Graphite/Epoxy and Glass Fabric/Epoxy Composites," Composite Materials: Testing and Design (Sixth Conference), ASTM STP 787, 1982, pp. 34-49

12. Wang, S.S., "Fracture Mechanics for Delamination Problems in Composite Materials," Journal of Composite Materials, vol. 17, May 1983, pp. 210-223

13. Nishioka, T. and Atluri, S.N., "A Simple Estimation of Stress Intensity Factors for Through-Cracks in Angle-Ply Laminates," Engineering Fracture Mechanics, vol. 16, No. 4, 1982 pp. 573-583

14. Herakovich, C.T., "On the Relationship Between Engineering Properties and Delamination of Composite Materials," Journal of Composite Materials, vol. 15, July 1981, pp. 336-348

15. Herakovich, C.T., "Influence of Layer Thickness on the Strength of Angle-Ply Laminates," Journal of Composite Materials, vol. 16, May 1982, pp. 216-227

16. Williams, J.G. and Rhodes, M.D., "Effect of Resin on Impact Damage Tolerance of Graphite/Epoxy Laminates," Composite Materials: Testing and Design (Sixth Conference), ASTM STP 787, 1982, pp. 34-49

17. Varma, D.S., et. al., "Interlaminar Shear Properties of Graphite Fiber, High-performance Resin Composites," Polymer Composites, vol. 4, no. 2, Apr. 1983, pp. 98-103

18. Hahn, H.T. and Hwang, D.G., "Failure Characterization of a Graphite/Epoxy Laminate Through Proof Testing," Composite Materials: Testing and Design (Sixth Conference), ASTM STP 787, 1982, pp. 34-49

19. Mumford, N.A. and Sasso, S.E., "Advanced Materials for Solid Rocket Composite Cases", presented at the 1985 JANAF Propulsion Meeting, 9-12 April 1985, San Diego, CA (Limited Distribution-U.S. Government Agencies Only)

**END**

**FILMED**

**11-85**

**DTIC**