

AD-A158 922

LASER PLUS SURFACE-DYNAMICS FACILITY(U) TORONTO UNIV
(ONTARIO) DEPT OF CHEMISTRY J C POLANYI 31 JUL 85
N00014-84-G-0184

1/1

UNCLASSIFIED

F/G 20/5

NL



		END
		FILED
		etc

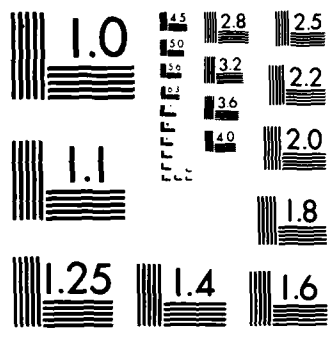

MICROCOPY RESOLUTION TEST CHART
NATIONAL BUREAU OF STANDARDS 1963-A

①

OFFICE OF NAVAL RESEARCH

RESEARCH GRANT

FINAL REPORT

for

August 1st 1984 to July 31 1985

GRANT NO.: NO0014-84-G-0184

GRANT TITLE: "Laser Plus Surface-Dynamics Facility"

PRINCIPAL INVESTIGATOR: J.C. Polanyi
 Department of Chemistry
 University of Toronto
 Toronto, Ontario M5S 1A1

Reproduction in whole or in part is permitted
 Document approved for public release; distribution unlimited.

Accession For	
NTIS GRA&I	<input checked="" type="checkbox"/>
DTIC TAB	<input type="checkbox"/>
Unannounced	<input type="checkbox"/>
Justification	
By _____	
Distribution/	
Availability Codes	
Dist	Avail and/or Special
A-1	

DTIC
 COPY
 INSPECTED

DTIC ELECTED
S **D**
 SEP 09 1985
 E

AD-A158 922

DTIC FILE COPY

85 09 06 08

A. Laser Development

The objective in this one-year study has been to develop a vacuum ultraviolet (VUV) laser suitable for investigating the simplest of chemical reactions

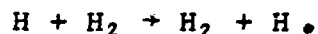

This reaction has been fundamental to the development of our understanding of chemical reactions in gases over the past half century, and could come to occupy a similar pivotal role in regard to the elucidation of the molecular dynamics of exchange reactions at surfaces.

In order to generate atomic H we have expanded HI from a quartz nozzle (0.1 mm I.D.) into a high vacuum chamber (10^{-6} Torr). The density of HI beyond the nozzle could readily be made ~ 0.01 Torr. A Lumonics TE 861-4 excimer laser with unstable resonator operating on KrF at 248 nm (65 mJ/pulse) was used to completely photolyse the HI.

When the HI was mixed (ahead of the nozzle) with D_2 , the reaction $H + D_2 \rightarrow HD + D$ took place in the jet. A second laser beam was then used (following variable time delay) to probe the reaction product D. This second laser beam consisted of radiation in the VUV that could be tuned to the Lyman- α wavelength of 121.6 nm for H, and 121.5 nm for D. This radiation was generated by passing the 20-30 mJ/pulse output from a Lambda Physik dye laser (Model FL2002, pumped by 240 mJ/pulse of 308 nm) into a cell filled with Kr at 40 Torr pressure. The incoming 364.6 or 364.5 nm radiation was tripled through third harmonic generation in the Krypton to give rise to the desired wavelengths [R. Hilbig and R. Wallenstein, IEEE J. Quantum Elect. QE-17, 1566 (1981);

K.H. Welge et al., Optics Comm. 37, 15 (1981)] Using 500 Torr Kr and approx 1,200 Torr Ar, while continuously circulating the Kr + Ar mixture through the cell, gave rise to a 80× enhancement in VUV output.

The reaction product D was excited from its 1^2S to 2^2P state by a VUV photon, and then ionized to D^+ by a second photon ($\lambda = 364.6$ nm). The D^+ was extracted into a differentially-pumped Wiley-McLaren 60 cm time-of-flight tube, and ions arriving at a Hamamatsu 19 stage ion-multiplier tube were measured. The resolution from the 60 cm drift tube was $\Delta m/m = 100$ at mass 80.

This approach has a sensitivity capable of yielding a S/N in the range 10^3 - 10^4 for measurement of the D^+ reaction product. Since only ~10% of the H formed in the jet suffers a collision before escaping, the reaction $H + D_2$ is being studied under single collision conditions. The collision energy is well-defined since it is determined by the wavelength of the photolytic radiation. This good S/N opens the way to experiments on $H + D_2 \rightarrow HD + D$ with state-selection of reagent collision energy plus vibrotational energy.

B. Lasers Applied to Surface Science

Funding under this one-year grant has assisted us in completing a "Laser Plus Surface Dynamics Facility" which had been previously designed and partially constructed with funds provided by the University of Toronto and by the Natural Sciences and Engineering Research Council of Canada. In what follows we describe some recent experiments on a simpler machine ('Apparatus I') which show the promise of the direction that we are taking, and then we outline the

progress made with Apparatus II.

B.1 Apparatus I.

The apparatus is shown schematically in figs. 1 and 2, and is described in the accompanying captions. This apparatus, constructed previous to the year under review, is a rudimentary version of that constructed with partial support from ONR funds (see B.2 below). Both are UHV machines with provision for moving the surface under study from a working upper level to a lower level which is reserved for characterisation of the surface (or adsorbate-covered surface). The differences between the two machines are suggested by the dimensions of the UHV chamber which in the case of Apparatus I is measured in inches (I.D. = 1-2") and in the case of Apparatus II is measured in feet (I.D. = 2 ft. in width and depth, and 3 ft. in height). As will be explained, this has important implications for the types of surface reaction that can be studied, and the range of product attributes that can be monitored.

In the small machine depicted in figs. 1 and 2 the surface can be dosed with molecular adsorbate, coming from a small moveable doser (not shown in the figs.) situated at either the 'working' level or the 'characterisation' level. The products can be examined (at the working level) for angular distribution, $P(\theta')$, within a limited range, and for translational energy, $P(T')$, using the mass spectrometer detector with time-of-flight (TOF). They can be characterised as to internal excitation, $P(V')$ and $P(R')$, using a tunable VUV laser (part A, above) to obtain LIF. The location of this laser beam is fixed (cf. the new machine). For characterisation the surface plus doser can be withdrawn to the lower level, where

they will be examined by electron diffraction (LEED) and by electron impact (Auger).

For studies of photo-induced processes at surfaces an excimer laser - - designated "pump laser", PL in fig. 1 - - has its output reduced to a few mJ and is incident at a grazing angle ($\theta_i = 80-85^\circ$ from the normal) at the surface. Calculation shows that this produces negligible temperature rise of the surface.

As a test of the method we adsorbed 0.01 - 0.1 monolayers of CH_3Br on a clean single crystal of $\text{LiF}(001)$ and irradiated the crystal at glancing incidence with 1 - 6 mJ/pulse of 222 nm excimer laser radiation. A preliminary report of our findings has already appeared [E.B.D. Bourdon et al., J. Phys. Chem. 88, 6100 (1984)]. Photofragments, namely CH_3 radicals, were recorded leaving the crystal with a peak translational energy of 1.5 eV. There was strong evidence that the photolysis was occurring in the adsorbed state.

In the past year we have extended these experiments to include measurements of the angular distribution of the CH_3 . Despite our use of unpolarised light, we found that the photoproducts were peaked normal to the surface. This, coupled with the fact that the product translational excitation differs from that in gas-phase photodissociation, provides further strong evidence that CH_3Br is being dissociated while held bound (0.3 eV binding) to the cold (115 K) crystal surface.

The angular distributions that we have recorded during the past year using Apparatus I had to be obtained by rotating the uv-illuminated crystal relative to the mass spectrometer detector.

An immediate advantage of Apparatus II is that it will permit us to rotate the detector (mass spectrometer or laser probe), inside the UHV environment, around the crystal. As a consequence our angular distributions will be free from distortion due to changing uv laser intensity with crystal rotation. We shall also be able to use polarised uv, and keep the angle of the electric vector of the incident radiation relative to the crystal plane a constant while varying the angle of observation. This will, of course, only represent the first dividend from the new apparatus.

B.2 Apparatus II.

Apparatus II, has elements in common with Apparatus I. As is evident in the schematic shown in fig. 3, it has a working upper level and a lower level intended for surface characterisation of the crystal surface. It differs, however, from the small machine in various important respects. The two most significant, which could not be embodied in a small machine, are (a) the ability to attack the surface, or adsorbate, with (one or two) accelerated beams of atomic or molecular reagents, and (b) the ability to steer the VUV LIF probe, or the mass spectrometer which substitutes for it, to all points of interest within the UHV chamber. The importance of using beams of reagents (coming from a differentially-pumped source chamber; fig. 3) is that one can more readily obtain a known surface coverage, and that one can dose the surface with high fluxes of reactive atoms and radicals.

Examples of reactive atomic reagents with which we have worked in the past, using collimated seeded supersonic beams of characterised energy-distribution (as will be the case in the

present work) are atomic hydrogen and atomic halogens. Such reagents are of theoretical (and practical) interest, since they assist in identifying and varying the reactive specie. The steerable VUV LIF probe will consist for example, of the laser described under A, entering the UHV chamber approximately down its central axis, through a bakeable UHV-compatible LiF window (fig. 3). The fluorescence will be viewed by a solar blind photomultiplier tube (P in fig. 3) mounted behind LiF collimating lenses. Rotation of a large UHV flange mounted on the top of the main chamber will swing the LIF viewing point around the front surface of the crystal.

A further degree of freedom is introduced by the fact that the fluorescence detection system is separately rotatable (see gears in fig. 3), hence the distance of the viewing point from the crystal can also be altered without breaking the vacuum. In a normal vacuum system this might represent an excessive degree of sophistication, but in UHV ($\sim 10^{-11}$ Torr) breaking the vacuum is a time-consuming and deleterious process.

Apparatus II is intended for a range of studies of atomic reactions at, and with, surfaces. Prominent among these will be the photo-induced reactions outlined for Apparatus I. Particular attention will be paid to reactions forming H_2 and its isotopes, in view of our ability to probe this specie by LIF in the VUV, and also particularly in view of the unique simplicity of surface-hydrogen interactions and hence the potential that such studies offer for theoretical modeling of surface reaction at the molecular level.

In the past year, with the aid of ONR funds, we have been able to complete the construction and assembly of the main elements of this apparatus. It is now UHV degreased, leak-tested, and under vacuum. The final components have been designed, and are under construction. These are (a) the UHV crystal manipulator, (b) the rotatable mass-spectrometer flange with double differential pumping of a quadrupole mass-spectrometer, and (c) the ion lens that deflects the ions (following their formation in the ionizer of the mass spectrometer which detects photoproducts coming from the crystal surface) along the vertical axis of the mass spectrometer. Items (b) and (c) hang upon a rotating flange that is interchangeable with the laser-induced fluorescence top-flange shown in fig. 3; the mass spectrometer itself substitutes for the photomultiplier P in that figure.

These three final items will be installed in the coming months. Apparatus II will therefore be full operational early in 1986.

Figure Captions

- Fig. 1 Side-view of UHV Apparatus No. I, designed for laser photolysis studies of adsorbed molecules, using TOF (time-of-flight: see inset at lower right) and mass-spectrometric detection to identify and to measure $P(E_{\text{TRANS}})$ (the translational energy-distribution) for each product. The pump laser (I_{PL}) is an N_2 or excimer laser. The adsorbed layer is dosed onto the crystal, which is located in the figure at the target of I_{PL} . Reflected laser light is absorbed by multiple reflection in a carefully de-gassed laser beam-dump (shaded conical object). The crystal can be translated downward for in situ LEED/AUGER examination, before and after photolysis experiments.
- Fig. 2 The figure shows the same side-view of Apparatus No. 1 as in the previous figure. The crystal is shown rotated 180° from its orientation in fig. 1. Products of photolysis (indicated by an ellipse, tangent to the crystal) are shown being probed by LIF (laser induced fluorescence). The laser source that induces the fluorescence has its axis perpendicular to the figure; its cross-section in the plane of the figure is labelled I_{FL} . The fluorescence, in the VUV, is measured by a solar-blind photomultiplier tube. The photomultiplier will be gated so that I_{FL} is measured only after I_{PL} has terminated (as

Fig. 2
Cont'd.

is evident from the inset below, there is a period of $\geq 5\mu$ sec between these two events. All windows and optics that bring I_{FL} into the UHV system and subsequently collect the fluorescence, are made of lithium fluoride (bakeable for windows integral with the chamber). The crystal is also shown (in broken lines) slightly lowered for measurement of fluorescent intensity at a different angle to the normal. The procedure for TOF of individual internal energy states of photolytic fragments is illustrated at the lower right of the figure.

Fig. 3

Schematic of UHV Machine II. Main chamber 36" high, 28" wide and 26½" deep (all O.D.), constructed from stainless steel. Provision is made for 15" diam. rotating flanges at top, at side (left of figure), and at base. All three flanges rotate while UHV is maintained. In addition there is a 15" hinged access door with UHV seal, at the side from which the machine is being viewed in this fig. The crystal surface is at location S for studies of reaction products by Laser Induced Fluorescence (LIF). The ovens, O, located in the source chamber (chamber 1) constitute the source for atomic or molecular beams; O indicates two ovens, located above and below the plane of this figure. The jets from these ovens are skimmed en route from chamber 1 to chamber 2. The beams are then differentially pumped in the successive chambers 3 and 4. They converge (see arrow B) at the surface,

Fig. 3
Cont'd.

S, of the crystal. The pair of ovens can be lowered in vacuum, within chamber 1, by 7" to position O'. They then converge on the crystal surface at S' (see arrow B'). The top rotating flange carries the probe laser window and the photomultiplier housing, P, as well as the associated optics (the latter is separately rotatable with the result that LIF can be measured not only at various angles to the surface, but also at various distances from the surface). By rotating the side flange (left of fig.) the crystal surface can be lowered 7" to position S' where it is subjected to cleaning and characterisation; cleaning is by means of the electron gun, EG, and argon ion gun, AG. Characterisation of the surface is by LEED/Auger, at L. Since the identical atomic/molecular beams can be made to converge on the crystal surface at the lowered position S', the surface can be characterised either in the clean state or under the experimental conditions employed for the study of surface reaction.

The LEED/Auger analyser can be withdrawn to the side of the vessel by actuating the trolley, T, under vacuum. This allows the products arising from atom/molecule beams converging at the lower beam position B' to be analysed mass-spectrometrically (at M). The rotating flange below allows the quadrupole mass-spectrometer, M, to be rotated around the crystal surface at S'.

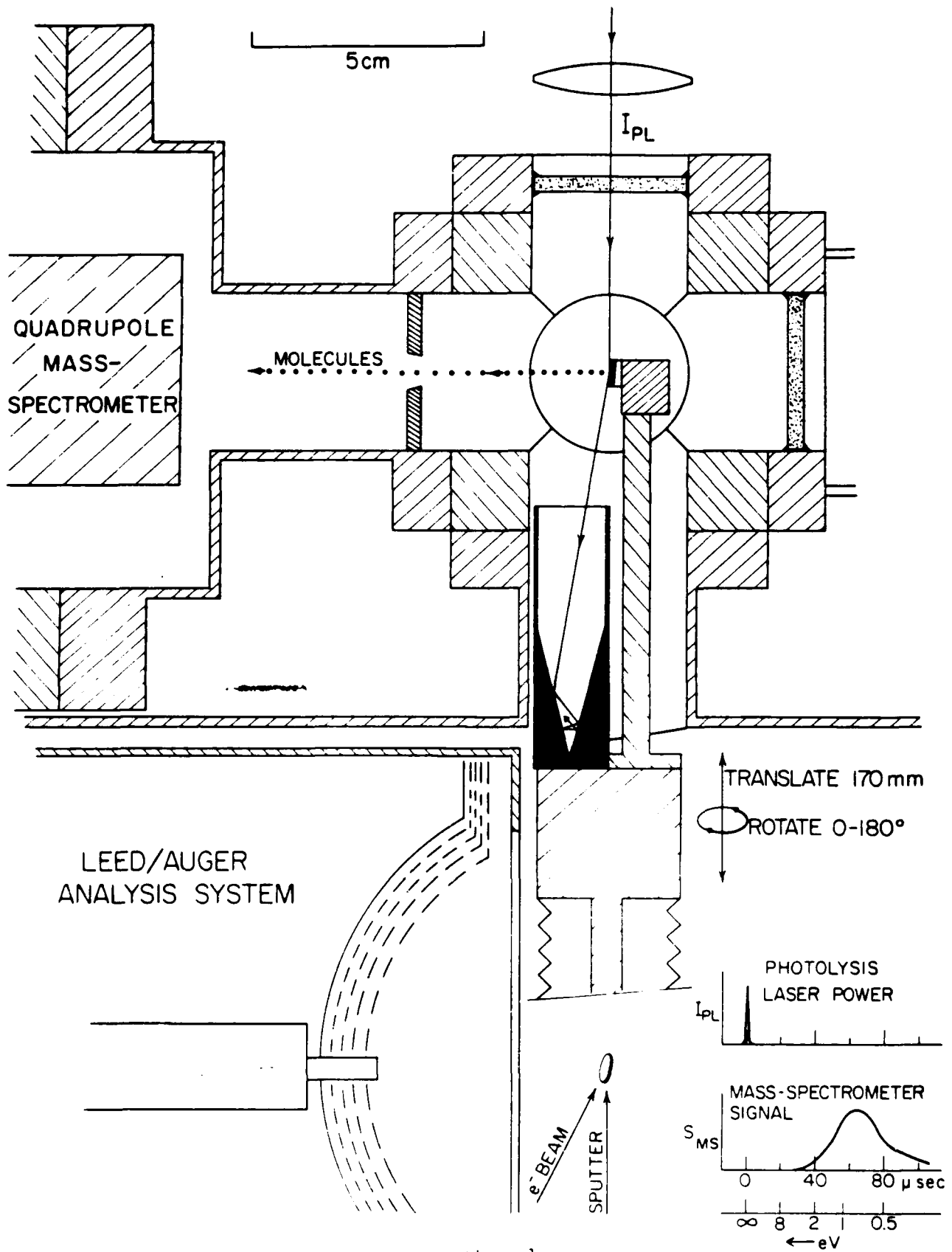

Fig. 1

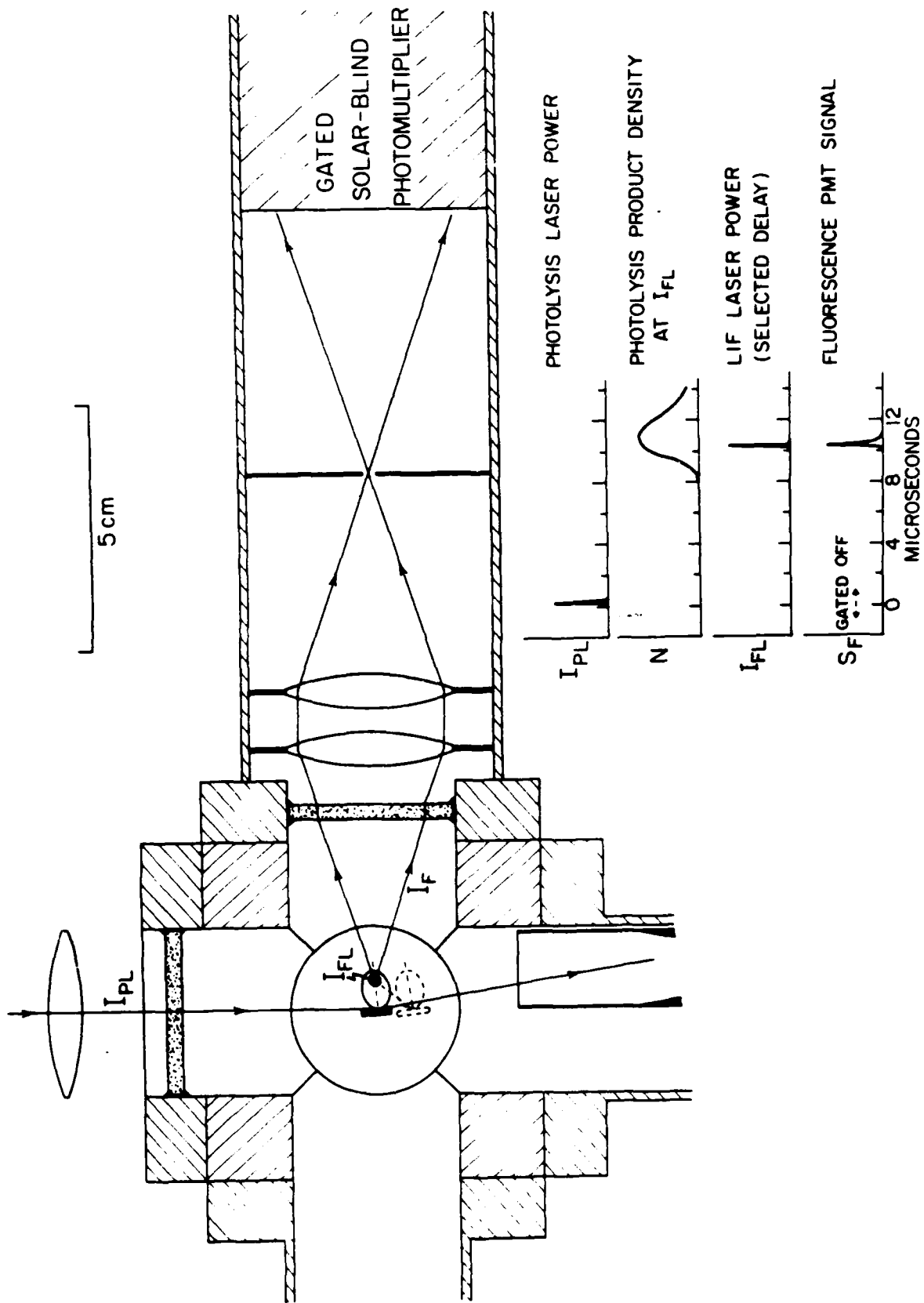

Fig. 2

UHV MACHINE II

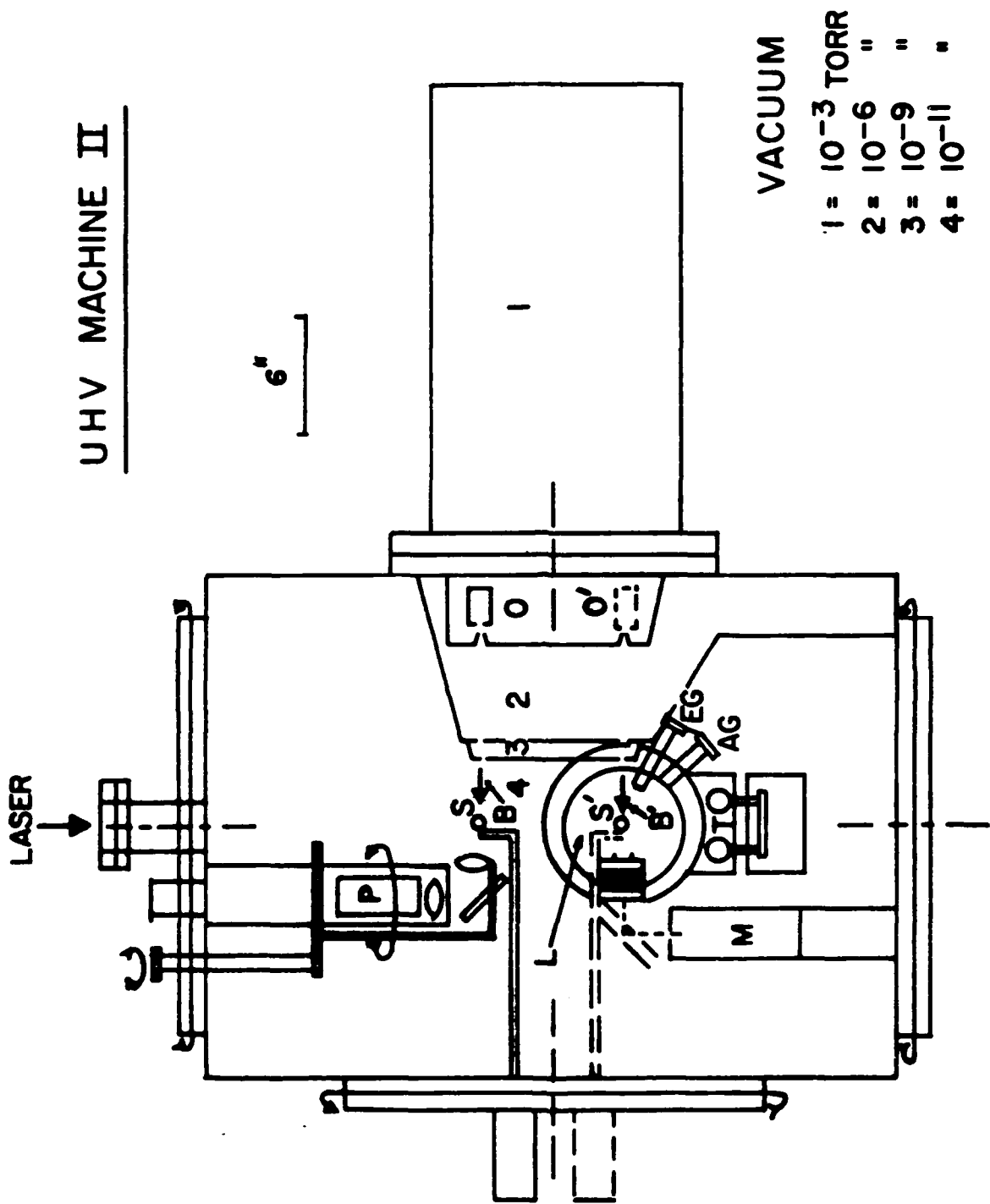

Fig. 3

END

FILMED

10-85

DTIC