

NATIONAL BUREAU OF STANDARDS  
MICROCOPY RESOLUTION TEST CHART

AFOSR-TR- 85 - 0566

AD-A158 931

Final Report

to the

Air Force Office of Scientific Research

DROPLET SIZE AND EVAPORATION RATE WITHIN A TWO-PHASE FLOW  
BY MORPHOLOGY-DEPENDENT RESONANCES IN THE OPTICAL SPECTRA

AFOSR Grant No. F49620-82-K-0005

November 15, 1981 - December 31, 1985

Richard K. Chang, Bao-Teh Chu, and Marshall B. Long

Principal Investigators

Yale University  
Applied Physics and Mechanical Engineering  
New Haven, Connecticut 06520

DTIC FILE COPY

DTIC  
ELECTE  
AUG 29 1985

G

April 1985

Approved for public release;  
distribution unlimited.

85 8 21 15

Unclassified

AD-A158931

SECURITY CLASSIFICATION OF THIS PAGE

REPORT DOCUMENTATION PAGE

1a REPORT SECURITY CLASSIFICATION <b>Unclassified</b>		1b. RESTRICTIVE MARKINGS	
2a SECURITY CLASSIFICATION AUTHORITY		3. DISTRIBUTION/AVAILABILITY OF REPORT <b>Approved for Public Release; Distribution of this report is unlimited.</b>	
2b DECLASSIFICATION/DOWNGRADING SCHEDULE			
4 PERFORMING ORGANIZATION REPORT NUMBER(S)		5 MONITORING ORGANIZATION REPORT NUMBER(S) <b>AFOSR-TR- 85 - 0566</b>	
6a NAME OF PERFORMING ORGANIZATION <b>Yale University Applied Physics and Mech. Engineering</b>	6b OFFICE SYMBOL <i>(If applicable)</i>	7a. NAME OF MONITORING ORGANIZATION <b>Air Force Office of Scientific Research/NA</b>	
6c ADDRESS (City, State and ZIP Code) <b>P.O. Box 2157, Yale Station New Haven, CT 06520</b>		7b. ADDRESS (City, State and ZIP Code) <b>Building 410 Bolling Air Force Base, DC 20332-6448</b>	
8a NAME OF FUNDING/SPONSORING ORGANIZATION <b>AIR FORCE OFFICE OF SCIENTIFIC RESEARCH</b>	8b OFFICE SYMBOL <i>(If applicable)</i> <b>NA</b>	9. PROCUREMENT INSTRUMENT IDENTIFICATION NUMBER <b>F49620-82-K-0005</b>	
8c ADDRESS (City, State and ZIP Code) <b>BOLLING AFB DC 20332-6448</b>		10 SOURCE OF FUNDING NOS.	
11. TITLE (Include Security Classification) <b>DROPLET SIZE AND EVAPORATION RATE WITHIN A TWO-PHASE FLOW BY</b>		PROGRAM ELEMENT NO. <b>61102F</b>	TASK NO. <b>A3</b>
12 PERSONAL AUTHOR(S) <b>MORPHOLOGY-DEPENDENT RESONANCES IN THE OPTICAL SPECTRA (Unclassified) Richard K. Chang, Boa-Teh Chu, and Marshall B. Long</b>		PROJECT NO. <b>2308</b>	WORK UNIT NO.
13a TYPE OF REPORT <b>Final</b>	13b. TIME COVERED FROM <b>11/15/81</b> TO <b>12/31/84</b>	14. DATE OF REPORT (Yr., Mo., Day) <b>April 10, 1985</b>	15. PAGE COUNT <b>23</b>
16 SUPPLEMENTARY NOTATION <i>cont. fig 1</i>			
17. COSATI CODES		18 SUBJECT TERMS (Continue on reverse if necessary and identify by block number)	
FIELD	GROUP	SUB GR.	
			<b>Fluorescence</b> (Lorenz/Mie formalism; Two-phase flow)
			<b>Evaporation rate</b> (Dynamic surface tension;
			<b>Liquid droplets;</b> Morphology-dependent resonances. <i>←</i>
19 ABSTRACT (Continue on reverse if necessary and identify by block number)			
<p>In two-phase chemically reacting flows, the size, shape, and chemical content of the fuel droplets affect combustion and their chemical by-products. A new <u>in-situ</u> and nonintrusive optical technique has been developed which can provide highly accurate (one part in 100,000) size and shape determination, as well as provide chemical speciation of the majority species forming the droplet. This all-optical technique makes use of the morphology-dependent resonances (MDRs) of spheres, spheroids, or any shape that enables an internal wave to travel around a great circle with appropriate phase shift. In addition, these MDRs in the fluorescence spectra of dye-doped droplets flowing in a linear stream have provided information on the following: (1) evaporation rate of interacting droplets flowing in the ambient or heated environment;</p> <p style="text-align: right;">(Continued)</p>			
20 DISTRIBUTION/AVAILABILITY OF ABSTRACT <b>UNCLASSIFIED/UNLIMITED <input checked="" type="checkbox"/> SAME AS RPT. <input type="checkbox"/> DTIC USERS <input type="checkbox"/></b>		21 ABSTRACT SECURITY CLASSIFICATION <b>Unclassified</b>	
2. NAME OF RESPONSIBLE INDIVIDUAL <b>LEONARD H CAVENY</b>		22b TELEPHONE NUMBER <i>(Include Area Code)</i> <b>(202) 467-4937</b>	22c OFFICE SYMBOL <b>AFOSR/NA</b>

19. Continued:

(2) condensation rate of interacting droplets flowing in a saturated vapor; and (3) surface tension and bulk viscosity of individual droplets which have been perturbed by a laser beam so as to cause slight shape distortions, e.g., from spheres to oblate or prolate spheroids. MDRs can provide wavelength selective high Q optical feedback for the internally generated fluorescent and Raman radiation. By utilizing this high optical feedback, lasing from individual dye-tagged droplets of .02 mm radius has been achieved. The potential of using bright lasing droplets as markers in flow diagnostics is promising. Stimulated Raman scattering from individual droplets of .02 mm radius has also been achieved. With this technique, chemical speciation can be determined from the absolute Raman shift, and sizing can be deduced from the regularly spaced morphology-dependent peaks present throughout the Raman linewidth.

Accession For	
NTIS GRANT	<input checked="" type="checkbox"/> <input type="checkbox"/> <input type="checkbox"/>
DTIC TAB	
Unannounced	
Justification	
By _____	
Distribution/	
Availability Codes	
Dist	Avail. and/or Special
AI	



CONTENTS

	Page
Abstract	1
Research Objectives	2
Status of Research	3
Evaporation and Condensation Rates from Flowing Droplets	3
Shape Oscillation and Distortions	8
Laser Emission from Individual Droplets	13
Chemical Speciation of Individual Droplets	15
References	19
Publications	20
Lectures and Papers Delivered	21
Personnel	23
Degrees Earned	23
Patents	23

AIR FORCE OFFICE OF SCIENTIFIC RESEARCH  
NOTICE OF TRANSMISSION  
This technical report is approved for distribution  
approved for distribution  
Distribution  
MATTHEW J. KENNEDY  
Chief, Technical Information Division

## ABSTRACT

In two-phase chemically reacting flows, the size, shape, and chemical content of the fuel droplets affect combustion and their chemical by-products. A new in-situ and nonintrusive optical technique has been developed which can provide highly accurate (one part in  $10^4-10^5$ ) size and shape determination, as well as provide chemical speciation of the majority species forming the droplet. This all-optical technique makes use of the morphology-dependent resonances (MDRs) of spheres, spheroids, or any shape that enables an internal wave to travel around a great circle with appropriate phase shift. In addition, these MDRs in the fluorescence spectra of dye-doped droplets flowing in a linear stream have provided information on the following: (1) evaporation rate of interacting droplets flowing in the ambient or heated environment; (2) condensation rate of interacting droplets flowing in a saturated vapor; and (3) surface tension and bulk viscosity of individual droplets which have been perturbed by a laser beam so as to cause slight shape distortions, e.g., from spheres to oblate or prolate spheroids. MDRs can provide wavelength selective high Q optical feedback for the internally generated fluorescent and Raman radiation. By utilizing this high optical feedback, lasing from individual dye-tagged droplets of  $\sim 20 \mu\text{m}$  radius has been achieved. The potential of using bright lasing droplets as markers in flow diagnostics is promising. Stimulated Raman scattering from individual droplets of  $\sim 20 \mu\text{m}$  radius has also been achieved. With this technique, chemical speciation can be determined from the absolute Raman shift, and sizing can be deduced from the regularly spaced morphology-dependent peaks present throughout the Raman linewidth.

1000-10000

US-C

 {
   
 20000
   
 100000
 }

 100000
   
 100000

## RESEARCH OBJECTIVES

In two-phase chemically reacting flows, the size and shape distribution of the fuel droplets affects combustion and chemical by-products. The evaporation rate of a single droplet within a spray depends on the heat flux directed toward it and on its vapor environment. Both these quantities depend on the proximity of neighboring droplets and also on the collective evaporation and combustion properties of all the droplets. The temperature-dependent surface tension and the bulk viscosity of a single droplet affect the droplet shape as well as its shape oscillations as the droplets flow in a combustor and are acoustically perturbed. A comprehensive review of the combustion of droplets of liquid fuel has been published.<sup>1</sup>

The initial objective of this program was to develop a new quantitative optical technique for determining the evaporation rate of droplets in a spray. The standard in-situ optical diagnostic technique can only infer the average radius of many droplets based on an inversion technique which uses the angular pattern of the elastically scattered radiation  $I_{\text{ela}}(\theta, \lambda_1)$  at wavelength  $\lambda_1$ . We have recently developed a new technique for direct size determination of an individual droplet by measuring the spectral distribution of the fluorescence intensity  $I_{\text{flu}}(\theta_o, \lambda)$  collected at a fixed angle  $\theta_o$ . Sharp peaks occur in  $I_{\text{flu}}(\theta_o, \lambda)$  as a result of MDRs which correspond to the natural optical frequencies of the micro-object. Physically, these resonances result from internal electromagnetic waves near the perimeter which are internally reflected at the interface and are in phase on successive trips around the micro-object. Thus, by using this phase-sensitive

technique, highly accurate (one part in  $10^4$ - $10^5$ ) information can be obtained about the radius or change in radius of individual droplets which are either flowing or stationary.

The subsequent objective of this program was to extend the technique based on the MDRs in the fluorescence profile to the characterization of other important parameters of flowing droplets, namely, shape determination and chemical speciation of individual droplets. As a consequence of the shape determination objective, we realized that the surface tension and viscosity of individual droplets can be deduced from the oscillations associated with shape distortions. Furthermore, as a result of the chemical speciation objective, we embarked on an entirely new research path, an investigation of the nonlinear optical effects from individual droplets, particularly the laser emission from dye-doped droplets and stimulated Raman scattering from pure liquid droplets.

#### STATUS OF RESEARCH

##### Evaporation and Condensation Rates from Flowing Droplets

The evaporation rate of a single droplet in a spray of randomly sized droplets is too complex to be calculated theoretically. However, for the one-dimensional case of equally spaced droplets flowing in a linear stream, the theoretical treatment is greatly simplified and can be solved analytically.<sup>2,3</sup> Experimentally, the existing technique to determine the evaporation rate is to measure the burning time of droplets in a linear array as a function of droplet spacing and droplet diameter. Instead of this burning rate approach, we wanted to develop

an in-situ nonintrusive optical technique to determine the evaporation/condensation rate of interacting droplets flowing in a linear stream.

Highly monodisperse ethanol droplets tagged with Rhodamine 6G dye are generated by a modified Berglund-Liu vibrating orifice generator. The droplets have a radius in the 10-50  $\mu\text{m}$  range with a monodispersity of one part in  $10^4$ - $10^5$  and spacing within a linear stream of two droplet diameters. The fluorescence spectra from ten droplets are dispersed by a spectrograph and simultaneously detected by a two-dimensional array detector (a SIT low-light-level television camera). The experimental arrangement is shown schematically in Fig. 1.

The fluorescence spectra from ten droplets can be detected and recorded after a single 15 ns  $\text{N}_2$  laser pulse. Typical sets of data for droplets emerging into ambient air, heated air, and ethanol vapor saturated environment are shown in Fig. 2. The evaporation of droplets within a linear stream can be readily determined by measuring the wavelength shift of specific MDRs from successive droplets further downstream from the orifice since the droplet decreases in size monotonically with time after exiting the orifice. Our results demonstrate that the wake of preceding droplets significantly decreases the evaporation rate of a droplet within the linear stream.<sup>4</sup>

Since MDRs in the fluorescence spectra occur at specific  $x = 2\pi a/\lambda_{\text{flu}}$  values, the change in droplet radius can be accurately determined from the wavelength shifts of an MDR peak, as those shown in Fig. 2. The relationship between radius change  $\Delta a$  and MDR wavelength shift  $\Delta\lambda$  is as follows:

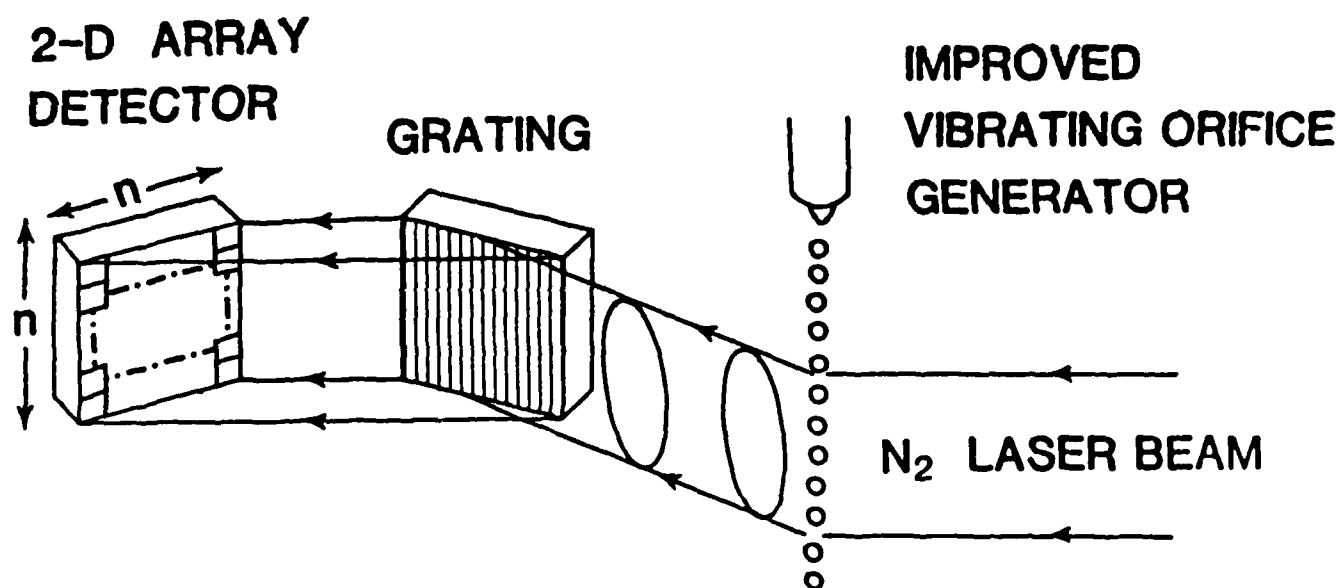

Fig. 1. Detection of the fluorescence spectra from a linear array of interacting droplets. From the MDRs in the fluorescence spectra, both the size and shape changes can be measured to a high accuracy.

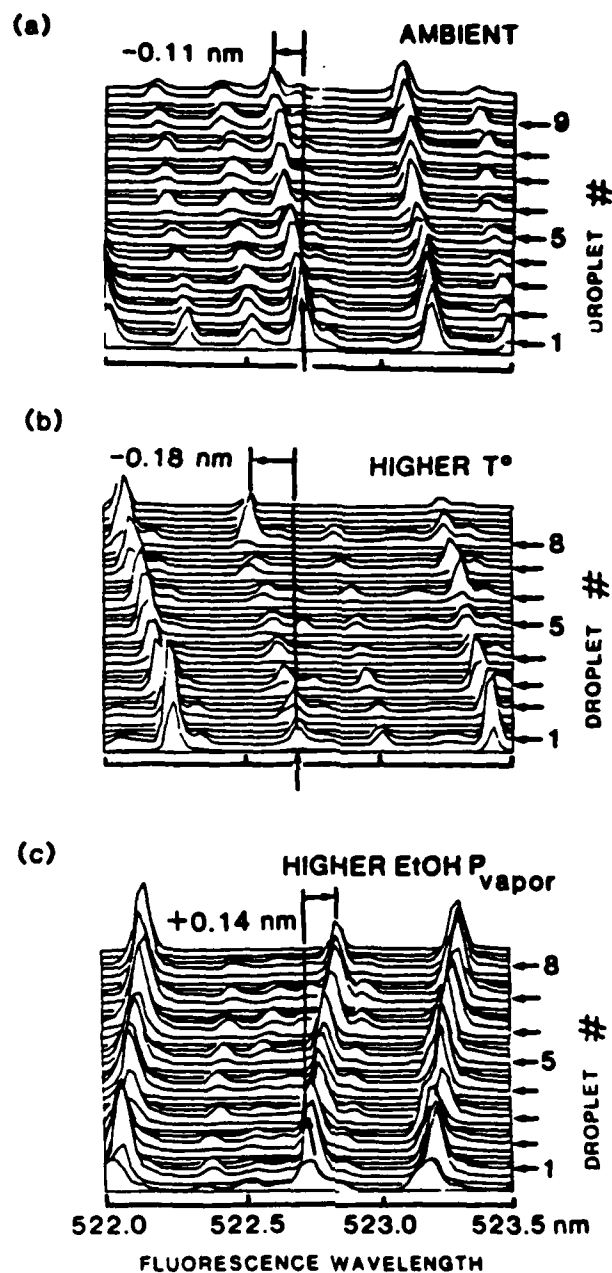

Fig. 2. The single laser shot fluorescence spectra from 8 to 10 spatially resolved droplets emerging from a droplet generator into several different environments: (a) ambient; (b) higher temperature; and (c) room temperature but higher ambient ethanol vapor pressure (EtOH  $P_{\text{vapor}}$ ). The accumulated wavelength shift for 8 to 10 droplets is indicated for a specific MDR peak. Shifts to shorter wavelengths (blue shift) and longer wavelengths (red shift) correspond to evaporation and condensation, respectively.

$$\Delta a = \frac{a}{\lambda_{flu}} \Delta \lambda \quad \text{Eq. (1)}$$

The ratio of  $a/\lambda_{flu}$  is in the 40-100 range and thus provides a magnification factor that relates  $\Delta \lambda$  to  $\Delta a$ . In Fig. 2(a)  $a = 30 \mu\text{m}$ ,  $\lambda_{flu} = 0.522 \mu\text{m}$ , and  $\Delta \lambda$  for nine droplets is  $-1.1 \text{ \AA}$ . Thus, the accumulation of  $\Delta a$  for nine droplets is  $71 \text{ \AA}$ , or  $7.1 \text{ \AA}$  for each droplet. The time interval between the droplets is totally determined by the oscillator frequency driving the vibrating orifice. For the case shown in Fig. 2, the time interval is  $28 \mu\text{sec}$ . The evaporation rate based on our measurement is therefore  $\Delta a/\Delta t = -25 \mu\text{m}/\text{sec}$ , which is  $\sim 25\%$  of that estimated for a single isolated droplet flowing at  $\sim 4 \text{ m}/\text{sec}$  in the ambient. The evaporation rate in a heated ambient environment [as shown in Fig. 2(b)] is increased by  $(1.8/1.1)$  times relative to that in a room temperature environment. The sign of the MDR shift  $\Delta \lambda$  is changed when condensation occurs [note Fig. 2(c)]. The red wavelength shift ( $+\Delta \lambda$ ) implies a  $\Delta a$  increase while a blue wavelength shift ( $-\Delta \lambda$ ) implies a  $\Delta a$  decrease.

In principle, this MDR technique can be extended to the measurement of evaporation/condensation rates of a spray. Conceptually, one tagged fluorescent droplet is launched into a spray of untagged droplets. By measuring the fluorescence spectra at time  $t$  and then at a later time  $t + \Delta t$ , the wavelengths at which MDRs occur will provide absolute radius information ( $a$ ), and the wavelength shifts ( $\Delta \lambda$ ) of a particular MDR peak during the  $\Delta t$  interval will then give the droplet radius change ( $\Delta a$ ) as in Eq. (1). Consequently,  $\Delta a/\Delta t$  can be deduced.

Of particular interest to spray combustion diagnostics is the dependence of  $\Delta a/\Delta t$  as a function of spray density, temperature, and average spray radius.

### Shape Oscillation and Distortions

Shape distortions from a perfect sphere will also lead to wavelength shifts of the MDRs.<sup>5</sup> The MDRs of dielectric objects with axisymmetric shapes can be readily calculated, particularly for spheroids, provided that the semi-major to semi-minor axis ratio ( $a/b$ ) is not too far from 1 and the size of  $a$  is less than 100  $\mu\text{m}$ .

Small amplitude distortions of a sphere can be analyzed mathematically by spherical harmonic decomposition.<sup>6</sup> The  $L = 0$  component describes a static radius change of an undistorted sphere. The  $L = 1$  component gives rise to a rigid displacement of the droplet, and the axisymmetric mode ( $m = 0$ ) of the  $L = 2$  component corresponds to a prolate or an oblate spheroid. The  $L = 2$  components of the driven oscillations and the damped oscillations of a freely oscillating droplet have been most readily observed in the case of acoustically forced millimeter-sized droplets.<sup>7</sup> The damping rate for the  $L = 3, 4,$  and 5 components was increasingly larger than that for the  $L = 2$  component.<sup>7</sup>

Thus far, shape distortions of very large liquid droplets ( $a = 1 \text{ mm}$ ) suspended in another fluid or attached to a fine fiber have been investigated by a form of elastic scattering, i.e., rainbow interferometry.<sup>7</sup> We have extended the technique using MDRs in the fluorescence spectra to study shape oscillations of flowing droplets.

- 4/27/84 - "Laser Scattering from Dielectric Microparticles," Chemistry Department, Weizmann Institute, Rehovot, Israel.
- 6/27/84 - "Laser Emission and Nonlinear Optical Effects from a Liquid Droplet Irradiated by High Energy Lasers," ARO 1984 CRDC Scientific Conference on Obscuration and Aerosol Research, Aberdeen Proving Ground, MD.
- 6/28/84 - "Mirror-Fiber Distance Dependence of the Angular Scattering Pattern and the Morphology-Dependent Resonances in the Elastic Scattering," ARO 1984 CRDC Scientific Conference on Obscuration and Aerosol Research, Aberdeen Proving Ground, MD.
- 8/7/84 - "Elastic and Inelastic Scattering from Dielectric and Metallic Microparticles," International Workshop on the Electromagnetic Response of Surfaces, Cholula, Mexico (Invited Talk).
- 9/6/84 - "Linear and Nonlinear Optical Scattering from Dielectric Microparticles," Fukui University, Fukui, Japan.
- 10/17/84 - "Morphology-Dependent Resonances in Dielectric and Metallic Microstructures," University of Rochester, Rochester, NY.
- 10/19/84 - "Surface Plasmons and Morphology-Dependent Resonances in Micron-Size Objects," Brown University, Providence, RI.
- 11/27/84 - "Spectral and Intensity Behavior of Individual Droplets in a Two-Phase Flow," International Conference on Lasers '84, San Francisco, CA (Invited Talk).

## LECTURES AND PAPERS DELIVERED

- 2/17/82 - "Shape and Size Dependent Resonances in the Laser Scattering Spectra of Fibers," First Annual Conference of the American Association for Aerosol Research, Santa Monica, CA (Invited Talk).
- 2/23/82 - "Particle Sizing by Light Scattering," Sandia National Laboratories, Livermore, CA.
- 2/26/82 - "Determination of Liquid Droplet Evaporation Rates in a Spray by Inelastic Light Scattering," AFOSR Combustion Workshop, Stanford University, Stanford, CA.
- 3/31/82 - "What Can Be Done with Morphology-Dependent Resonances in Laser Scattering?" Physics Department, Brooklyn College, Brooklyn, NY.
- 6/24/82 - "Size Determination of Flowing Aerosols by Light Scattering," U.S. Army Chemical Laboratory Conference on Obscuration and Aerosol Research, Aberdeen, MD.
- 9/21/82 - "Morphology-Dependent Resonances in Raman Scattering from Microparticles," Ninth Annual Meeting of the Federation of Analytical Chemistry and Spectroscopy Societies (FACSS), Philadelphia, PA (Invited Talk).
- 12/15/82 - "Fluorescence and Raman Emission from Microstructures," International Conference on Lasers '82, New Orleans, LA (Invited Talk).
- 2/19/83 - "Optical Scattering with Microparticles," Physics Department, Indian Institute of Technology, Madras, India.
- 6/28/83 - "Laser Scattering from Dielectric Microparticles," Schlumberger-Doll Research Center, Ridgefield, CT.
- 9/30/83 - "Laser Scattering from Dielectric Microparticles," General Motors Research Center, Warren, MI.
- 2/27/84 - "Laser Scattering from Dielectric Microparticles with and without Gain," IEEE Distinguished Lecturer Series, Electrical Engineering Department, University of Utah, Salt Lake City, UT.
- 3/21/84 - "Droplet Evaporation Rate Determination by Morphology-Dependent Resonances," AFOSR Conference on Diagnostics of Reacting Flow, New Haven, CT.

## PUBLICATIONS

1. H.-M. Tzeng, K.F. Wall, M.B. Long, and R.K. Chang, "Evaporation and Condensation Rates of Liquid Droplets Deduced from Structure Resonances in the Fluorescence Spectra," *Opt. Lett.* 9, 273 (1984).
2. H.-M. Tzeng, K.F. Wall, M.B. Long, and R.K. Chang, "Laser Emission from Individual Droplets at Wavelengths Corresponding to Morphology-Dependent Resonances," *Opt. Lett.* 9, 499 (1984).
3. J.B. Snow, S.-X. Qian, and R.K. Chang, "Stimulated Raman Scattering from Individual Water and Ethanol Droplets at Morphology-Dependent Resonances," *Opt. Lett.* 10, 37 (1985).
4. Richard K. Chang, "Elastic and Inelastic Scattering from Dielectric and Metallic Microparticles," in Proceedings of the International Workshop on the Electromagnetic Response of Surfaces, Cholula, Puebla (Mexico), August 6-10, 1984, R.G. Barrera and W.L. Mochan, editors, 1984, p. 109.
5. H.-M. Tzeng, M.B. Long, R.K. Chang, and P.W. Barber, "Laser-Induced Shape Distortions of Flowing Droplets Deduced from Morphology-Dependent Resonances in Fluorescence Spectra," to be published in *Opt. Lett.*

## REFERENCES

1. A. William, "Combustion of Droplets of Liquid Fuels: A Review," *Combust. Flame* 21, 1 (1973).
2. M. Labowsky, "Calculation of the Burning Rates of Interacting Fuel Droplets," *Combust. Sci. Tech.* 22, 217 (1980).
3. J.J. Sangiovanni and M. Labowsky, "Burning Times of Linear Fuel Droplet Arrays: A Comparison of Experiments and Theory," *Combust. Flame* 47, 15 (1982).
4. H.-M. Tzeng, K.F. Wall, M.B. Long, and R.K. Chang, "Evaporation and Condensation Rates of Liquid Droplets Deduced from Structure Resonances in the Fluorescence Spectra," *Opt. Lett.* 9, 273 (1984).
5. P.W. Barber, J.F. Owen, and R.K. Chang, "Resonant Scattering for Characterization of Axisymmetric Dielectric Objects," *IEEE Trans. Antennas Propag.* AP-30, 168 (1982).
6. H. Lamb, *Hydrodynamics* (Dover Publications, New York, 1945), p. 475 and p. 639.
7. P.L. Marsten and R.E. Apfel, "Quadrupole Resonance of Drops Driven by Modulated Acoustic Radiation Pressure: Experimental Properties," *J. Acoust. Soc. Am.* 67, 27 (1980).
8. H.-M. Tzeng, M.B. Long, R.K. Chang, and P.W. Barber, "Laser-Induced Shape Distortions of Flowing Droplets Deduced from Morphology-Dependent Resonances in Fluorescence Spectra," *Opt. Lett.*, in press.
9. H.-M. Tzeng, K.F. Wall, M.B. Long, and R.K. Chang, "Laser Emission from Individual Droplets at Wavelengths Corresponding to Morphology-Dependent Resonances," *Opt. Lett.* 9, 499 (1984).
10. J.B. Snow, S.-X. Qian, and R.K. Chang, "Stimulated Raman Scattering from Individual Water and Ethanol Droplets at Morphology-Dependent Resonances," *Opt. Lett.* 10, 37 (1985).

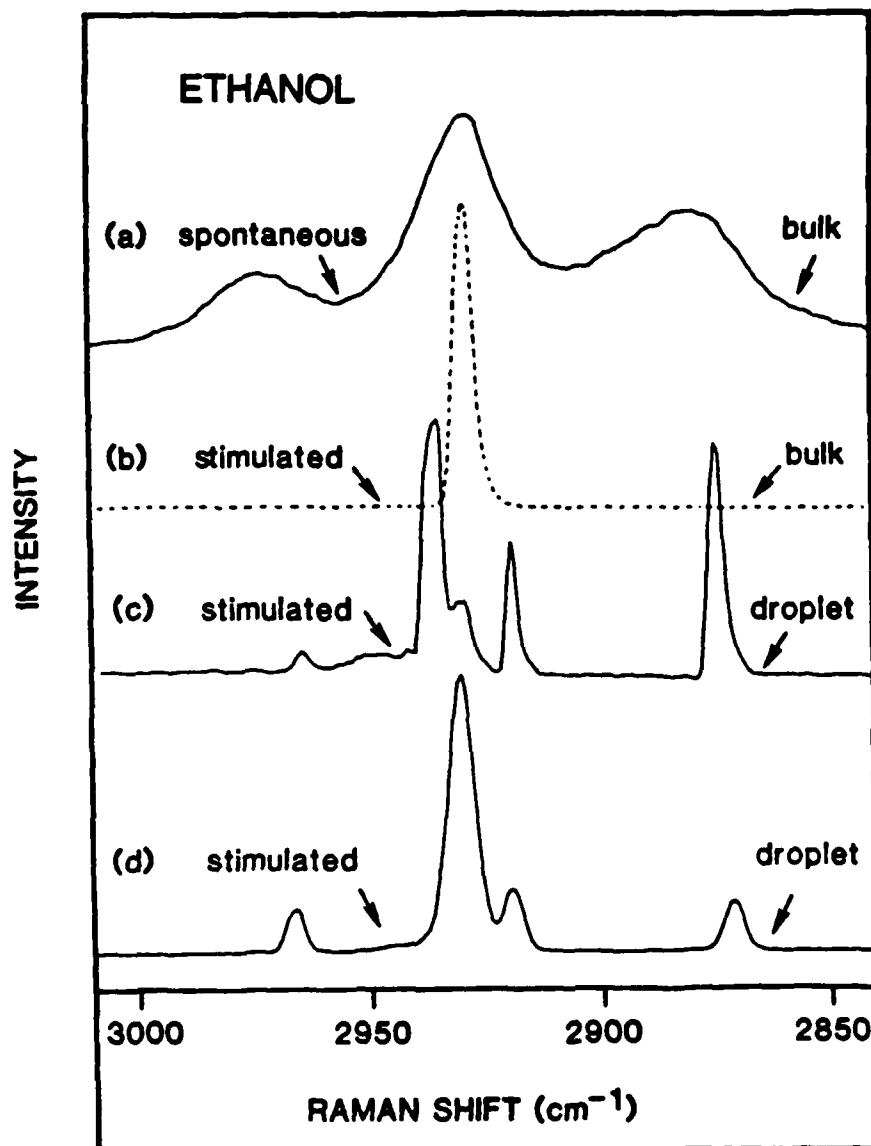

Fig. 7. The spontaneous Raman scattering (a) and SRS (b) from bulk ethanol in a cuvette. The SRS spectrum (c) from an ethanol droplet with the most intense peak is shifted from the maximum Raman cross section. Another typical SRS spectrum (d) from an ethanol droplet with the most intense peak is not shifted from the maximum Raman cross section, and additional peaks appear in the lower Raman cross section regions.

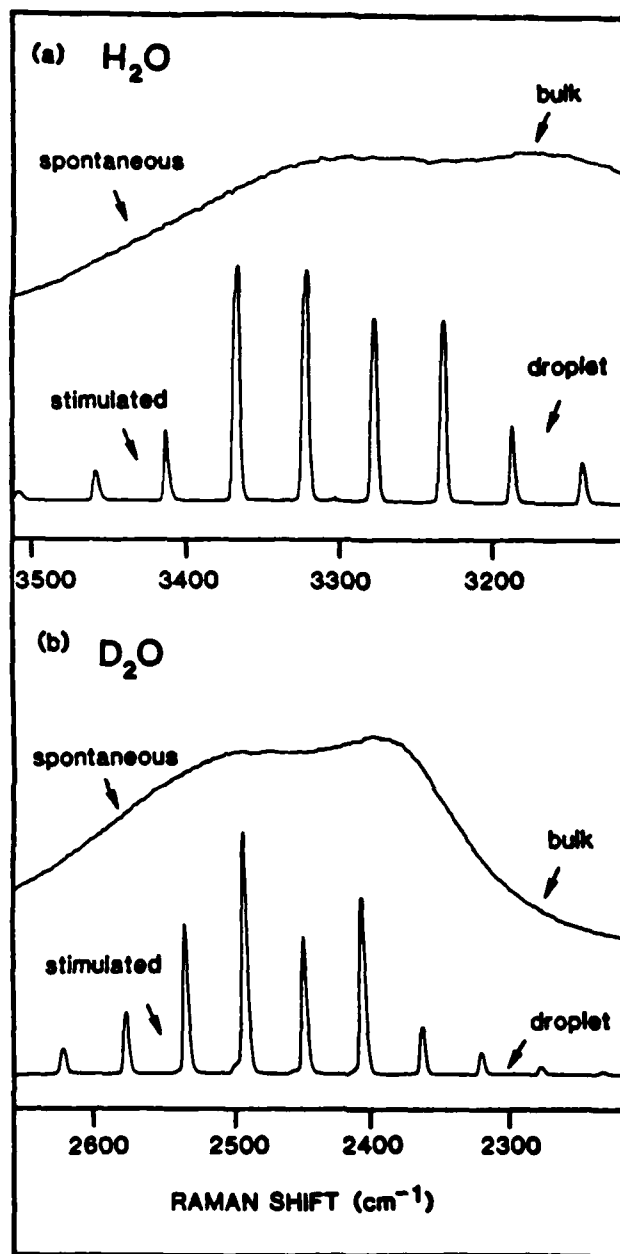

Fig. 6. The cw spontaneous Raman scattering from bulk H<sub>2</sub>O and D<sub>2</sub>O in a cuvette is shown in the upper spectrum of (a) and (b), respectively. The discrete peaks in the lower spectra of (a) and (b) are from a single droplet using a single 10-nsec laser pulse. These regularly spaced SRS peaks correspond to morphology-dependent resonances.

from the droplets are: (1) the occurrence of a series of spectrally narrow peaks that are nearly equally spaced in wavelength throughout the entire linewidth of the dominant spontaneous Raman vibrational modes (see Figs. 6 and 7); and (2) the input intensity required to achieve the SRS threshold for the droplet is an order of magnitude less than that for the corresponding bulk liquid with 2-4 cm path length. Both observations are consistent with MDRs resulting from the spherical liquid-air interface which forms an efficient optical cavity for the SRS as well as for laser emission (see Fig. 5). In principle, both the chemical species within the droplet and the droplet size can be determined from the SRS spectra, since the wavelength spacing between the MDR peaks is inversely related to the droplet radius. Further, the absolute wavenumber shifts of the MDRs relative to the input laser wavenumber are uniquely related to the molecular bond stretching frequency.

The extension of such nonlinear optical studies to individual droplets (containing no dye) is presently under way. The importance of phase-matching for four-wave mixing processes may override the enhancement of the internal electromagnetic fields which are confined near the circumference and have no well defined propagation vector since at MDRs the initial waves are counterpropagating around the circumference. Both CARS and coherent Raman mixing investigations on individual H<sub>2</sub>O and ethanol droplets are also presently under way.

correspond to the MDRs. The laser emission was noted to consist of spectrally narrow peaks spanning the fluorescence gain profile. The output-vs-input intensity dependence was noted to be linear at low input power and was followed by an exponential growth, finally reaching a saturation region at higher power.

As an extension of this preliminary result, it may be possible to use the coherent but nondirectional laser emission from individual particles as active markers for flow-field visualization and remote illumination. In particular, new applications may be viable with coherent emission droplets as velocimetry markers in otherwise optically dense two-phase flows and in overwhelmingly high elastic scattering environments such as near a solid boundary. New research has just been initiated on the nonlinear optical emission from water droplets and ethanol droplets with and without Rhodamine or Courmarin dyes.

#### Chemical Speciation of Individual Droplets

In the combustion and turbulence diagnostic field, the standard techniques for chemical speciation of bulk samples is spontaneous Raman scattering and coherent anti-Stokes Raman scattering (CARS). We have found that neither spontaneous Raman scattering nor CARS utilize the large enhancement of the internal fields at incident wavelengths or the enormous  $Q$  for optical feedback at the Stokes shifted wavelength. However, stimulated Raman scattering (SRS) from individual  $H_2O$  or ethanol droplets at wavelengths commensurate with MDRs has recently been observed.<sup>10</sup> Two notable features in the SRS emission

## TWO INTERNAL COUNTER PROPAGATING

WAVES

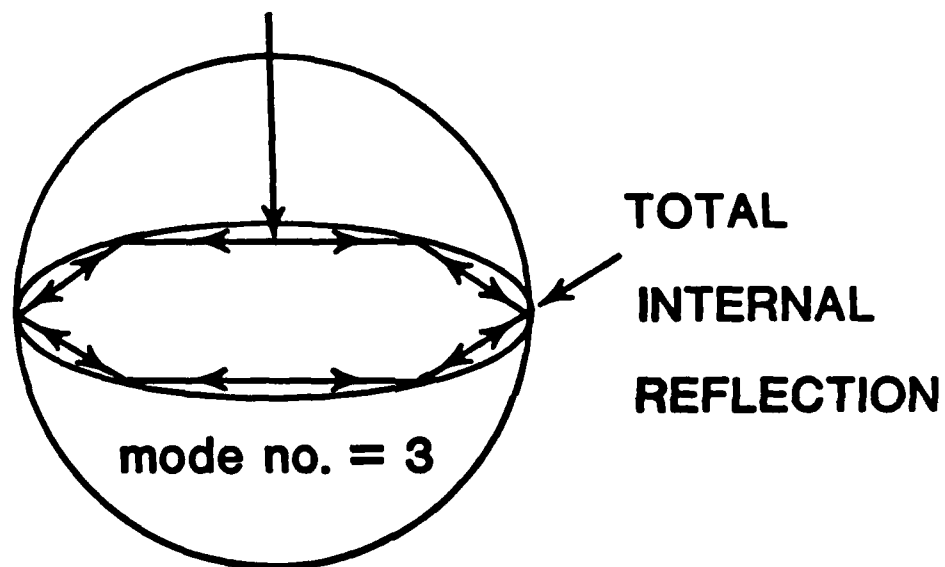

## LASER DROPLET CAVITY

Fig. 5. Optical wave structure within a droplet. Fluorescence radiation within the droplet undergoes total internal reflection at the liquid-gas interface. The droplet acts as an optical resonator for counterpropagating waves around the circumference.

orifice, or entering a region of nonuniform acceleration, can be made by following a particular dye-tagged droplet as a function of time. The sampling rate of the fluorescence spectra must be faster than the shape oscillation rate, in order to satisfy the Nyquist criterion. We are presently developing a visual technique that makes use of the laser radiation produced inside individual droplets. Since the laser emission is confined mostly near the circumference, the photographs of these lasing droplets highlight the liquid air interface of spherical and/or nonspherical droplets.

#### Laser Emission from Individual Droplets

In the course of measuring the size and shape distortions of flowing droplets tagged with dye molecules, we inadvertently caused laser emission from these individual droplets which are spherical or spheroidal in shape. Laser emission was observed from individual liquid ethanol droplets (radius  $\sim 30 \mu\text{m}$  and at room temperature) containing Rhodamine 6G at wavelengths commensurate with MDRs.<sup>9</sup> For a conventional dye laser, optical feedback (i.e., higher Q) at selected wavelengths is provided by an external wavelength dispersive element. For a droplet dye laser, higher Q at selected wavelengths is provided by the MDRs associated with the liquid-air interface of the droplet. At these resonances, standing waves result from the total internal reflection at the liquid-air boundary of counterpropagating waves close to the circumference of the droplet (see Fig. 5). Since the fluorescence linewidth of Rhodamine 6G is homogeneously broadened, the emitted radiation will strongly favor those wavelengths which

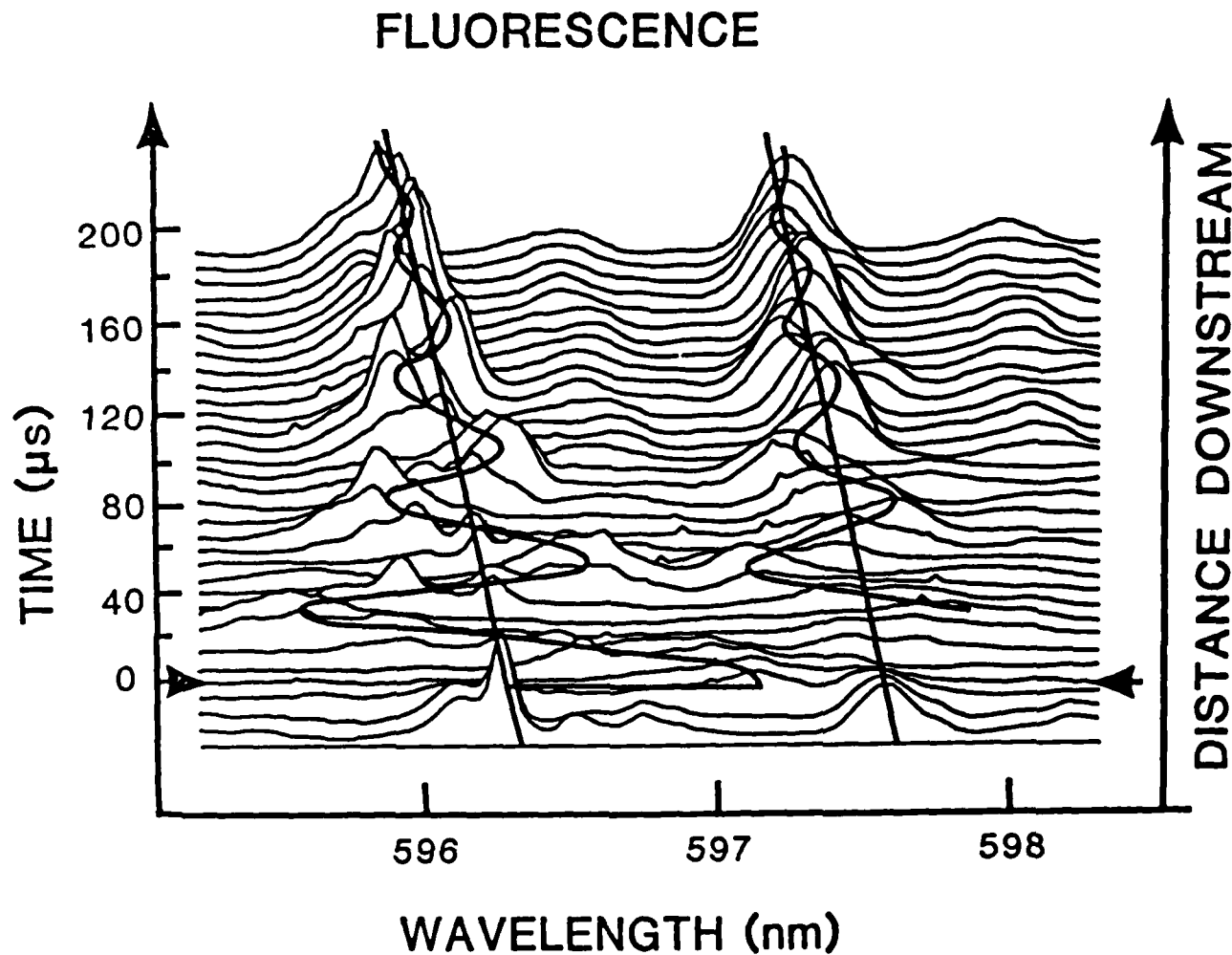

Fig. 4. Fluorescence spectra from laser-perturbed droplets downstream from the orifice. The distance downstream is plotted as time delay after the  $\text{Ar}^+$  laser perturbation defined as  $t = 0$ . Each droplet is perturbed by the  $\text{Ar}^+$  laser beams at a location indicated by the two arrows.

(514.5 nm, 8 mW each) impinging on a single ethanol droplet containing Rhodamine 6G ( $10^{-4}$  M) and having an absorption coefficient of 2.3 per cm at 514.5 nm and  $r = 21.1 \mu\text{m}$ . Two counterpropagating perturbing beams were used to minimize droplet displacement (the  $L = 1$  component) and hence optical misalignment with the spectrograph entrance slit. A pulsed  $\text{N}_2$  laser (5 mJ, 10 nsec) was focused into a sheet ( $\sim 3 \text{ mm} \times 1 \text{ mm}$ ) and excited fluorescence from approximately 12 droplets in the linear stream.

The surface tension and viscosity of an ethanol droplet flowing within a linear stream can be determined by measuring the wavelength oscillation of specific MDRs from successive droplets further downstream from a perturbation which can induce shape distortion. Figure 4 shows the MDRs in the fluorescence spectra from successive droplets downstream of the shape distorting perturbation. The shape distortion of droplets within the linear stream was assumed to be described by a quadrupole mode oscillation with an oscillation frequency  $(f_2)^2 = 2\sigma/\pi^2\rho a^3$  and a damping constant  $\tau_2 = a^2/5\nu$ , where  $\sigma$  is the surface tension,  $\rho$  is the density, and  $\nu$  is the kinematic viscosity. The MDRs exhibited a damped oscillation with a frequency  $f_2$  and damping constant  $\tau_2$ , values which are consistent with the surface tension and viscosity for ethanol. Our results compare well with electrodynamic calculations of the MDRs for equivolume droplets which oscillate between spheres and slightly oblate or slightly prolate spheroids.<sup>8</sup>

The extension of this MDR technique to the measurement of shape distortions of droplets after two-droplet collision, exiting an

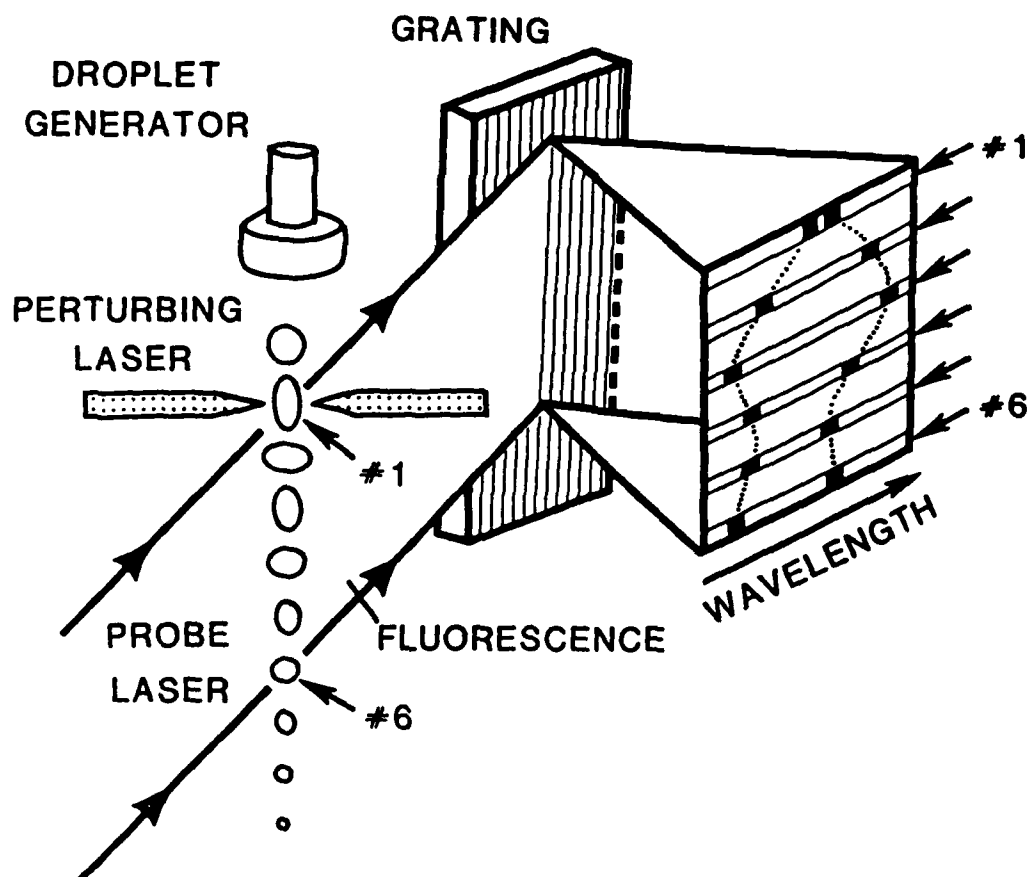

Fig. 3. Schematic of the experimental arrangement for the laser-induced shape oscillation of flowing droplets. Two counterpropagating beams ( $\text{Ar}^+$  laser, 514.5 nm) are focused on the absorbing dye-tagged ethanol droplet. A probe beam (pulsed  $\text{N}_2$  laser) is focused into a sheet and induces fluorescence from the droplet. The dispersed fluorescence spectra from highly monodispersed droplets in a linear stream are detected by a television camera placed at the exit focal plane of a spectrograph.

Upon perturbation by two counterpropagating laser beams which impart nonlinearly distributed heating within individual droplets, the initially spherical droplet distorts and surface tension causes the droplet to subsequently return to a sphere.

We reported<sup>8</sup> the first observation, to our knowledge, of damped shape oscillations (with  $L = 2$  components) of individual flowing droplets ( $r = 21.1 \mu\text{m}$ ) perturbed by a low energy laser with  $\lambda \ll r$ . Extremely small shape distortions (five parts in  $10^4$ ) can be detected by measuring the oscillations of the MDRs in the fluorescence spectra from a linear stream of dye-tagged ethanol droplets which are undergoing shape distortions in air. Such MDR oscillations have been compared with electromagnetic calculations for a sphere with  $x = 275$ , progressively evolving to prolate and oblate spheroids having a maximum ratio of semi-major to semi-minor axes  $a/b = 1 \pm 0.001$ . In contrast to the previous experiments,<sup>7,8</sup> the following differences are noteworthy: (1) no host liquid is required to suspend the droplets; (2) no levitation force is involved; (3) the droplets are not stationary; and (4) the wavelength of the perturbing force is no longer larger than the droplet size ( $\lambda \ll r$ ), which results in a nonuniform internal-field distribution. Using our technique, the surface tension of individual liquid droplets flowing in air can now be determined.

The experimental arrangement shown in Fig. 3 is an extension of the optical technique used to detect the evaporation and condensation rates of individual flowing droplets in a linear stream. Shape perturbation was initiated with two counterpropagating  $\text{Ar}^+$  laser beams

## PERSONNEL

In addition to the Principal Investigators, the following people have participated in this research project:

W. R. Bennett, Jr.	-	Professor of Applied Physics, Yale
J. F. Owen	-	Assistant Professor of Applied Physics, Yale
J. B. Snow	-	Associate Research Physicist, Yale
S.-X. Qian	-	Visiting Scientist from the Department of Physics, Fudan University, Shanghai
P. W. Barber	-	Consultant, Department of Electrical and Computer Engineering, Clarkson University

Graduate students were: Dominique Fourquette  
Kevin Smith  
Huey-Ming Tzeng  
Kevin Wall

Undergraduates were: Glenn Ellison  
Bevin Engelman  
George Trahan

## DEGREES EARNED

Mr. Huey-Ming Tzeng completed his graduate studies in December 1984. His thesis was entitled "Development of a Droplet-Characterization Method Based upon the Morphology-Dependent Resonances in the Fluorescence Spectrum."

Note: Ms. Dominique Fourquette completed her studies in March 1985 and will be awarded the Ph.D. degree in May 1985. Mr. Kevin Wall will also complete his studies shortly and be awarded the Ph.D. degree in May 1985.

## PATENTS

We plan to submit patent disclosures related to the following two subjects:

1. Coherent emission (lasing) from single droplets which may provide unique illumination sources.
2. Use of morphology-dependent resonances in the fluorescence/Raman emission spectra as an accurate size and shape measuring technique.

**END**

**FILMED**

**10-85**

**DTIC**