

AD-A158 972

METHODOLOGY FOR COMPUTER-SUPPORTED COMPARATIVE NAVAL  
SHIP DESIGN VOLUME 2(U) MASSACHUSETTS INST OF TECH  
CAMBRIDGE DEPT OF OCEAN ENGINEERING V H ROWLEY JUN 85  
N66314-78-A-8073

1/2

UNCLASSIFIED

F/G 13/10

NL

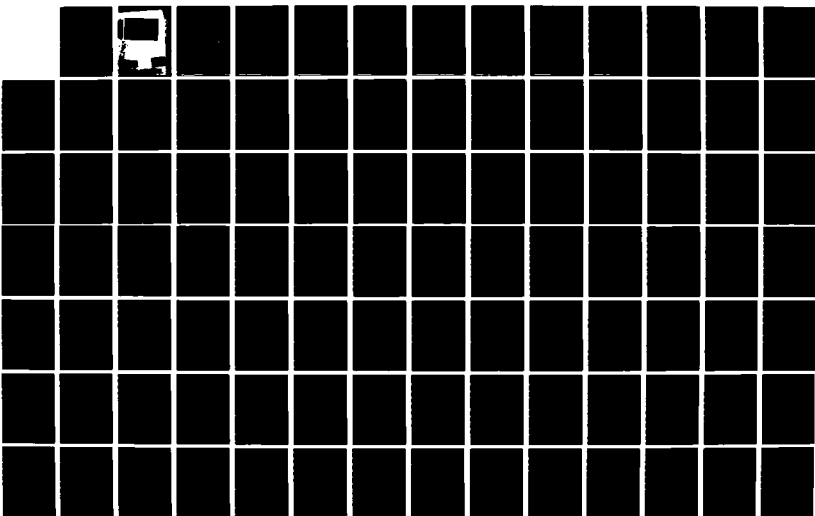

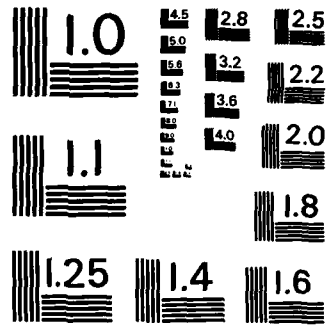

MICROCOPY RESOLUTION TEST CHART  
NATIONAL BUREAU OF STANDARDS-1963-A

**DEPARTMENT OF OCEAN ENGINEERING**

MASSACHUSETTS INSTITUTE OF TECHNOLOGY

CAMBRIDGE, MASSACHUSETTS 02139

---

REPRODUCTION OF DOCUMENTS REPORTED  
BY THE AUTHOR FOR THE OFFICE OF NAVAL RESEARCH

FORM NO. 1014

June 1964

*N66314-70-A-0073*

METHODOLOGY FOR COMPUTER-SUPPORTED  
COMPARATIVE NAVAL SHIP DESIGN

by

UDO HELMUT ROWLEY

B.S., University of Oklahoma  
(1977)

Submitted to the Department of  
Ocean Engineering  
in Partial Fulfillment of the  
Requirements of the Degrees of

OCEAN ENGINEER

and

MASTER OF SCIENCE IN MECHANICAL ENGINEERING

at the

MASSACHUSETTS INSTITUTE OF TECHNOLOGY

June 1985

© Udo Helmut Rowley 1985

The author hereby grants to M.I.T. and to the U.S. Government permission to reproduce and to distribute copies of this thesis document in whole or in part.

Signature of Author: Udo Helmut Rowley  
Department of Ocean Engineering, 10 May 1985

Certified by: C. Graham  
Prof. C. Graham Thesis Supervisor

Certified by: Thomas P. Bligh  
Prof. T.P. Bligh Thesis Supervisor

Accepted by: A. Douglas Carmichael  
Prof. A.D. Carmichael  
Chairman, Ocean Engineering Departmental Committee

Accepted by: [Signature]  
Chairman, Mechanical Engineering Department Committee



METHODOLOGY FOR COMPUTER-SUPPORTED  
COMPARATIVE NAVAL SHIP DESIGN

by

UDO HELMUT ROWLEY

Submitted to the Department of Ocean Engineering on May 10, 1985 in partial fulfillment of the requirements for the degrees of Ocean Engineer and Master of Science in Mechanical Engineering.

ABSTRACT

Comparative Naval Ship Design is used to compare new designs for trend analysis or to determine new technology impact on the "whole" ship. This process is at present manually time-intensive and tailored to the individual study. This thesis proposes a standardized methodology to display and compare ship designs using present computer technology. With full preparation for its implementation into a computer program, applicability is shown for direct interactive data base extraction, interfacing with the Navy's Advanced Surface Ship Evaluation Tool (ASSET) or simply using a microcomputer spreadsheet.

The proposed methodology will provide for a direct detailed graphical or tabular comparative analysis of any two ships, a bar graph analysis of up to six ships simultaneously, or a trend analysis to compare a new design to past similar designs. All proposed comparison parameters and indices are fully documented with definitions and significant relationships to overall ship impact. Additionally, a comparative analysis help option is presented to assist the designer in determining "impacts of" and "reasons for" significant differences of a two ship comparison.

Thesis Supervisor: Professor Clark Graham  
Title: Professor of Ocean Engineering

Thesis Reader: Professor Thomas P. Bligh  
Title: Associate Professor of Mechanical Engineering



X  
A-1 per format  
on file.

## ACKNOWLEDGEMENTS

The author first wishes to express his deepest thanks to Professor Clark Graham for the guidance he provided, the knowledge he shared and the motivation he instilled in me. Without his unselfish help and the significant time spent discussing the thesis, the final product would not have been the same.

The author additionally wishes to thank Mr. Dennis Clark and LCDR John Edkins, CN, at the Naval Ship Research and Development Center, for their support and assistance in getting me started on this project. Special thanks also goes to Professor Thomas Bligh for taking time out of his busy schedule to act as my thesis reader.

Finally, and equally as important, is the greatest measure of thanks to my wife, Becky, and my sons, Gary, Chris and John. Their unflinching support, patience and understanding, while competing with my studies for time and attention, has provided me with the inspiration and desire to excel.

## TABLE OF CONTENTS

	<u>Page</u>
Title Page .....	1
Abstract.....	2
Acknowledgements.....	3
Table of Contents.....	4
List of Figures.....	7
Chapter 1 - Introduction.....	9
1.1 Purpose.....	9
1.2 Basic Methodology.....	9
1.3 Synthesis Models.....	11
1.4 Data Bases.....	12
1.5 Spreadsheet Analysis.....	12
1.6 Interactive Computer Technology.....	13
1.7 Approach.....	14
Chapter 2 - Comparative Methodology.....	15
2.1 Definition of Analysis.....	15
2.2 Detail of Analysis.....	16
2.3 Methods of Analysis.....	16
2.3.1 Selection of Indices.....	16
2.3.2 Weight Classification System.....	18
2.3.3 Space/Volume Classification System.....	19
2.3.4 Electrical Classification System.....	19
2.3.5 Manning Classification System.....	19
2.3.6 Cost Accounting System.....	20

	<u>PAGE</u>
2.4 Types of Analysis.....	21
2.5 Programming Notes.....	21
Chapter 3 - Two-Ship Comparative Analysis.....	23
3.1 Methodology.....	23
3.2 Level 1: Primary Characteristics.....	31
3.3 Level 2: Resource Allocation.....	37
3.4 Level 3: Functional Investigation.....	45
3.5 Computer-assisted Comparative Analysis.....	55
3.5.1 User Interface Methodology.....	57
3.5.2 Structure Methodology.....	60
3.5.3 Example Investigations.....	62
3.5.3.1 New Technology Impact Evaluation..	63
3.5.3.2 DDG51 Comparison to DD963.....	68
3.5.4 Comparative Analysis Conclusion.....	76
3.6 Programming Notes.....	77
Chapter 4 - Multi-Ship Comparative Analysis.....	81
4.1 Methodology.....	81
4.2 Selected Indices.....	81
4.3 Programming Notes.....	85
Chapter 5 - Trend Comparative Analysis.....	87
5.1 Methodology.....	87
5.2 Time History Trends.....	88
5.3 "Triple-Plot" Trends.....	94
5.4 Programming Notes.....	102

	<u>PAGE</u>
Chapter 6 - Interface to an Integrated Data Base.....	105
6.1 Discussion.....	105
6.2 Implementation Requirements.....	106
Chapter 7 - Interface to ASSET.....	109
7.1 Discussion.....	109
7.2 Implementation Requirements.....	110
Chapter 8 - Conclusions.....	115
Chapter 9 - Recommendations.....	118
9.1 Implementation.....	118
9.2 Further Development.....	119
REFERENCES.....	120
APPENDIX A - Summary of Screens.....	123
APPENDIX B - Summary of Required Input Parameters with ASSET Relationship.....	128
APPENDIX C - DD963 vs DDG51 Comparison.....	136
APPENDIX D - ASSET Baseline vs New Technology Variant Comparison.....	153
APPENDIX E - Trend Comparative Analysis Data Base.....	170
APPENDIX F - Details of Parameters and Indices.....	183
Level 1: Primary Characteristics.....	185
Level 2: Resource Allocation.....	253
Level 3: Functional Investigation.....	301

## LIST OF FIGURES

<u>Figure Number</u>	<u>Title</u>	<u>Page</u>
2.1	Program Entry Flow Chart.....	22
3.1	"Singular" Display Graphic Screen Example.....	26
3.2	"Composite" Display Graphic Screen Example.....	27
3.3	Tabular Display Screen Example.....	28
3.4	Sample Comparative Analysis Screen.....	59
3.5	Two Ship Comparative Analysis Flow Chart.....	80
4.1	Example Multi-Ship Plot.....	82
4.2	Multi-Ship Comparative Analysis Flow Chart....	86
5.1	Example Displacement Trend Analysis.....	90
5.2	Example Volume Trend Analysis.....	91
5.3	Example Ship Density Trend Analysis Selecting Only one Type of Ship for Comparison.....	92
5.4	Example Human Support Specific Volume Trend Analysis Selecting Two Types of Ships for Comparison.....	93
5.5	Basic Triple Plots for $W_1$ and $W_2$ .....	95
5.6	Basic Triple Plots for $W_3$ and $W_4$ .....	96
5.7	Basic Triple Plots for $W_5$ and $W_6$ .....	97
5.8	Basic Triple Plots for $W_7$ .....	98
5.9	Example of New Frigate vs Standard Frigates Triple Plot Structural Trend Analysis.....	101
5.10	Trend Comparative Analysis Flow Chart.....	104
7.1	Proposed Comparative Ship Design Module Interface to ASSET.....	114

<u>Figure Number</u>	<u>Title</u>	<u>Page</u>
F.1	Ship Size Parameters.....	193
F.2	Prismatic Coefficient.....	202
F.3	Maximum Section Coefficient.....	202
F.4	Waterplane Coefficient.....	202
F.5	Speed - Power Curve.....	207

APPENDIX F  
DETAILS OF PARAMETERS/INDICES

This appendix will provide specific information on all indices and parameters used in the proposed methodology. Each indice and parameter description will provide details with respect to what the parameter/indice is and its significance in the impact of the overall comparative analysis. Additionally, for some of the major parameters and indices, expected ranges of values will be provided for modern monohull combatants of the frigate to cruiser range only. The explanation will provide the foundation of the computer-aided comparative analysis methodology relating to the screens, indices and parameters that should be examined if the comparative analysis option is invoked.

In this manner, if each indice and parameter has a logical path to examine, the overall flow of comparative analysis will be completed. Each indice and parameter is considered to be a "branch" on the overall "analysis tree" and is only examined to the next immediate level of analysis as discussed in section 3.5.

The appendix will provide the information that must be examined, either by screen or specific indice. The actual implementation of the logic used will be left to the programmer.

Nine different classes of ships were used to determine the expected range of values for selected parameters and indices. The

values were rounded to the nearest significant digit for the indice being examined. The classes of ships were:

FF-1052	DD-931	DDG-2	CG-26
FFG-7	DD-963	DDG-37	CG-47
		DDG-51	

Although it is understood that these ships do not include all classes of ships and some other classes may fall outside the ranges given in the explanations, it is felt that this is a good cross-section. The "expected range" value is for initial comparison only and these values are for parametric studies. It is the designers task to determine the impact of being outside the normal range of parametrics.

The indices and parameters are examined by screen grouping and levels.

## LEVEL 1: PRIMARY CHARACTERISTICS

The initial comparative analysis path looks primarily at level 2 resource allocation to examine the affected resources of the change in a primary characteristic of level 1. The resources examined are:

- weight
- volume
- energy
- manning
- cost

The analysis path additionally, where necessary, examines related level 1 characteristics that may have been affected by, or affected, the change. If the indice is a function of another parameter, the decision path will direct the user to that parameter for further analysis.

## SCREEN 1-1: COST AND SIZE CHARACTERISTICS

This screen is designed to give an overall view of the direct cost and size of the ships being compared in a tabular manner. The costs considered are the primary cost impacts in the ship design and are based on the Navy "P8" breakdown. It is important to note that in any cost comparisons, the user must be familiar with the source and accuracy of the cost data he is viewing and compare them accordingly.

## Displacement to Length Ratio

Symbol:  $\Delta_{f1}/(.01L_{bp})^3$  (tons/ft)

Definition: Used to express the displacement of a vessel in proportion to its length. This parameter was devised by Admiral D. W. Taylor and is used in calculating the power of ships and in recording the resistance data of models. The displacement is measured in tons, salt water and the length is the length between perpendiculars. The value of .01 was used only to give the coefficients convenient values. [10]

Significance: Most significant hull related parameter impacting on ship speed. Low displacement to length ratio ships have less resistance at high speeds than ships with high ratios.[13] High ratio ships will, therefore, require a higher shaft horsepower per ton displacement ratio.

Expected Range: The general rule of thumb for the ratio is about 50 for a very slender destroyer type hull and about 500 for a large tanker or bulk carrier of full form.[10] For the examined combatant ships [24].

frigates 56 - 57 tons/ft

destroyers 47 - 61 tons/ft except DDG-51 @ 83

cruisers 54 - 65 tons/ft

Comparative analysis examines:

- length between perpendiculars(1-1)
- full load displacement (1-1)

Significance: A significant change in draft may result from a change in loading or size of the ship. This may affect powering, seakeeping or efficiency.

Expected Range [24]: frigates 14-15 ft  
destroyers 15-20 ft  
cruisers 18-22 ft

Comparative analysis examines:

- volume (1-1)
- displacement (1-1)
- depth (1-1)
- all Shape Characteristics (1-2)
- all Mobility on Ship Performance Screen (1-3)
- all Hull Efficiency on Ship Performance Screen (1-3)

#### SCREEN 1-2: SHAPE CHARACTERISTICS

All shape characteristics are standard naval architecture indices and ratios used for the evaluation of the hullform and for comparisons. Since they are made up of primarily parameters of screen 1-1 and are directly impacted by them, all of these characteristics will examine their related primary size characteristics in the comparative analysis. Therefore all analysis will be in regard to screen 1-1 only and no second level analysis exists for this screen.

**Definition:** The vertical distance from the baseline to the tip of the freeboard deck beam at the side, measured at midships.[11] See figure F.1

**Significance:** A change in depth will generally result in a change in volume and displacement, as well as in the structural aspects of the depth of the box beams. If the draft additionally changes, then the powering, seakeeping and efficiency may be affected.

**Expected Range [24]:** frigates 30 - 31 ft  
destroyers 24 - 42 ft  
cruisers 38 - 42 ft

**Comparative analysis examines:**

- Volume (1-1)
- Displacement (1-1)
- Draft (1-1)
- all Shape Characteristics (1-2)
- all Mobility on Ship Performance Screen (1-3)
- all Hull Efficiency on Ship Performance Screen (1-3)

**Draft (maximum)**

**Symbol:** T (ft)

**Definition:** The depth of the ship below the designed waterline measured vertically to the lowest point on the bottom of the keel.[10] See figure F.1

Comparative analysis examines:

- Volume (1-1)
- Displacement (1-1)
- all Shape Characteristics (1-2)
- all Mobility on Ship Performance Screen (1-3)
- all Hull Efficiency on Ship Performance Screen (1-3)

**Beam (maximum at deck edge)**

Symbol:  $B_{max}$  (ft)

Definition: Maximum breadth of the ship measured at the deck edge. See figure F.1

Significance: Increasing the beam at the deck edge without increasing the beam at the waterline is possible by producing a flare which may be used to reduce or enhance radar cross section or to improve deck wetness qualities.

Expected Range [25]: frigate 45 - 47 ft

destroyer 44 - 55 ft except DDG-51 @ 67 ft

cruiser 54 - 55 ft

Comparative analysis examines:

- Volume (1-1)
- Displacement (1-1)
- all Mobility on Ship Performance Screen (1-3)
- all Hull Efficiency on Ship Performance Screen (1-3)

**Depth at midships**

Symbol: D (ft)

Significance: If this changes without a change in length between perpendiculars then the ship powering, seakeeping and efficiency may not be affected, however structural loading and ship arrangement will be.

Expected Range [25]: frigates 445 - 438 ft  
destroyers 418 - 563 ft  
cruisers 546 - 566 ft

Comparative analysis examines:

- Length Between Perpendiculars (1-1)
- Volume (1-1)
- Displacement (1-1)
- all Shape Characteristics (1-2)
- all Mobility on Ship Performance Screen (1-3)
- all Hull Efficiency on Ship Performance Screen (1-3)

#### Beam at Waterline

Symbol:  $B_{wl}$  (ft)

Definition: Molded breadth of the ship measured at the maximum section design waterline.[11] See figure F.1

Significance: Changing the beam affects the shape of the underwater hull, thereby affecting powering, stability, and arrangeability.

Expected Range [24]: frigate 45 - 47 ft  
destroyer 44 - 55 ft except DDG-51 @ 59 ft  
cruiser 54 - 55 ft

### Length Between Perpendiculars

Symbol:  $L_{bp}$  (ft)

Definition: The length of the ship between the forward and aft perpendiculars, as measured on the load waterline.[10]

See figure F.1.

Significance: The change of the length will not only affect the displacement and the volume but is a major driver of powering, seakeeping, structural loading, ship arrangement efficiency.

Expected Range [24]: frigates 407 - 415 ft  
destroyers 407 - 530 ft  
cruisers 524 - 529 ft

Comparative analysis examines:

- displacement (1-1)
- volume (1-1)
- all Shape Characteristics (1-2)
- all Mobility on Ship Performance Screen (1-3)
- all Hull Efficiency on Ship Performance Screen (1-3)

### Length Overall

Symbol:  $L_{oa}$  (ft)

Definition: The extreme length of the ship measured from the foremost point of the stem to the aftermost part of the stern.[11] See figure F.1

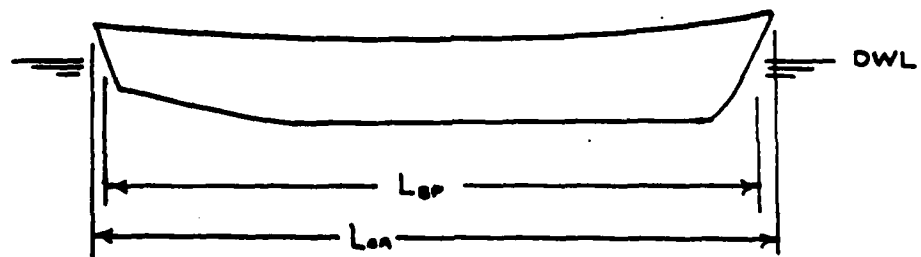
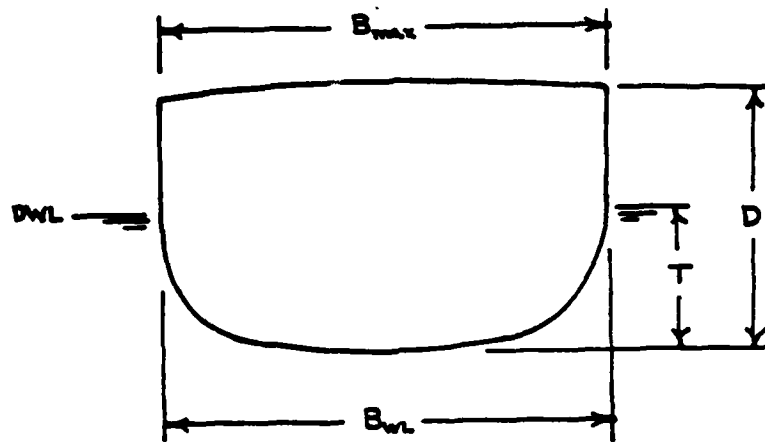

Figure F.1 Ship Size Parameters

density. This index is used in the trend analysis section "triple plots" to examine changes in structural, auxiliary, and outfit and furnishing weight groups W1, W5, and W6, respectively.

Expected Range [24]: frigates 16 - 18 lbs/ft<sup>3</sup>  
destroyers 16 - 22 lbs/ft<sup>3</sup>  
cruisers 19 - 21 lbs/ft<sup>3</sup>

Comparative analysis examines:

- full load displacement (1-1)
- volume (1-1)

#### Ship Density Light Ship

Symbol:  $\Delta_{LS}/\nabla$  (lbs/ft<sup>3</sup>)

Definition: The ratio of the light ship displacement to the total enclosed volume.

Significance: This is a second indication of spaciousness and how the volume drives the design. In this case, the density is that of just the light ship parameters without the load items.

Expected Range [24]: frigates 12 - 13 lbs/ft<sup>3</sup>  
destroyers 12 - 16 lbs/ft<sup>3</sup>  
cruisers 14 - 15 lbs/ft<sup>3</sup>

Comparative analysis examines:

- light ship displacement (1-1)
- volume (1-1)

both combat systems and HM&E systems, arrangement tightness standards, human support standards, deck heights, and arrangement efficiency of the hull. As with displacement, U.S. ships grew in volume from 1940 to 1975 but have shown a reversal of this trend in several of the more recent designs.

Expected Range [24]: frigates 500,000 - 532,000 ft<sup>3</sup>  
destroyers 414,000 - 1,034,000 ft<sup>3</sup>  
cruisers 850,000 - 1,103,000 ft<sup>3</sup>

Comparative analysis examines:

- Ship Density (1-1)
- All Functional Volume Allocation fractions (2-6)
- All Full Load Functional Weight Alloc fractions (2-3)
- All Functional Cost Allocation fractions (2-12)
- All Functional Energy Allocation fractions (2-8)
- All Manning Allocation fractions (2-9)

#### Ship Density Full Load

Symbol:  $\Delta_{f1}/\nabla$  (lbs/ft<sup>3</sup>)

Definition: The ratio of the full load displacement to the total enclosed volume.

Significance: This is an indication of spaciousness and how significantly the volume drives the design. The larger the ship density value, the more tightly packed (dense) the ship is. The trend since 1940 has shown a decrease in

**Definition:** The weight of the ship including hull, machinery, outfit, equipment and liquids in machinery [11], which include the seven SWBS groups and the margin weight.

**Significance:** Light ship displacement has the greatest effect on the basic construction cost of the ship and is a function of ship size, ship systems and material used.

**Expected Range [24]:** frigates 2700 - 3000 tons  
destroyers 2700 - 6700 tons  
cruisers 5300 - 7200 tons

**Comparative analysis examines:**

- All Cost and Size Characteristics (1-1)
- All Shape Characteristics (1-2)
- All Light Ship Functional Weight Alloc fractions (2-3)
- All Functional Volume Allocation fractions (2-6)
- All Functional Cost Allocation fractions (2-12)
- All Functional Energy Allocation fractions (2-8)
- All Manning Allocation fractions (2-9)

#### **Total Enclosed Volume**

**Symbol:**  $\nabla$  (ft<sup>3</sup>)

**Definition:** The sum of the enclosed hull and deckhouse volume of the ship.

**Significance:** Volume is the major driver of the weight of the ship through its influence on structure, outfitting and distributed systems. It is impacted by the selection of

includes liquids, crew and effects, ordnance, and aviation weights.

Significance: U.S. ships have exhibited an almost constant growth in full load displacement in the years 1940 to 1975. This pattern has shown a reversal with the limiting in size and cost of DDG-51, FFG-7 and CG-47. A change may be the result of a change in load weights or a change in volume requirements, as well as a possible difference in shape characteristics.

Expected Range [24]: frigates 3700 - 4100 tons  
destroyers 3900 - 8400 tons  
cruisers 7800 - 9600 tons

Comparative analysis examines:

- All Cost and Size Characteristics (1-1)
- All Shape Characteristics (1-2)
- All Full Load Functional Weight Alloc Fractions (2-3)
- All Functional Volume Allocation fractions (2-6)
- All Functional Cost Allocation fractions (2-12)
- All Functional Energy Allocation fractions (2-8)
- All Manning Allocation fractions (2-9)

#### Light Ship Displacement

Symbol:  $\Delta_{1s}$  (Tons)

- P.M. Growth	4.5%	5.0%
- HM&E GFE	3.0%	2.0%

Significance: Changes as overall total costs change, and is a function of ship size and complexity.

Comparative analysis examines:

- HM&E GFE Cost fraction (2-11)
- All Functional Allocation Cost fractions (2-12)

### Total Ship Cost

Symbol:  $C_t$

Definition:  $C_t = C_{bc} + C_{oth} + C_{csgfe}$

Total cost of the ship.

Significance: Function of all individual cost components, which in turn are a function of the complexity and size of the ship.

Comparative analysis examines:

- All Ship Size (1-1)
- All Functional Allocation Cost fractions (2-12)
- All Cost fractions (2-13)

### SHIP SIZE:

#### Full Load Displacement

Symbol:  $\Delta_{fl}$  (Tons)

Definition: Equals the weight of the water displaced and is the sum of the light ship weight plus the loads, which

and ordnance equipment supplied by the government to the contractor for installation. Actual installation costs of this equipment are included in its respective SWBS cost group of the basic construction cost.

Significance: Function of the complexity and size of the installed electronics and weapons systems.

Comparative analysis examines:

- Combat Systems Cost fraction (2-12)
- Combat Systems GFE/Lead Ship Cost fraction (2-13)
- Combat Systems GFE/Follow Ship Cost fraction (2-13)

#### Other Costs

Symbol:  $C_{oth}$

Definition: Includes all those miscellaneous costs that are generally fixed percentages of the total cost and do not affect the comparison individually. An additional cost that has been included in this area is that of HM&E GFE which is becoming increasingly smaller. These costs and the guideline percentages of total cost that they comprise include:

	Lead Ship	Follow Ship
- Plans	9.0%	0.5%
- Change orders	3.0%	2.0%
- NAVSEA support	2.5%	1.0%
- Escalation	5.5%	7.0%

**TOTAL COSTS:**

NOTE: User has the option to view either "lead" ship or "follow" ship costs:

**Basic Construction Cost**

Symbol:  $C_{bc}$

Definition: Costs paid directly to the shipbuilder. These costs include and are broken into the following areas:

- \* all costs related to shipyard direct labor, overhead and material associated with each of the seven Navy standard SWBS [22] groups.
- \* Design and construction margin
- \* Design and Engineering (Group 8) Costs.
- \* Assembly Construction Services (Group 9) Costs.
- \* Shipbuilder Profit.

Significance: This cost is a function of the design complexity and the size of the ship. In general, this results in about 28-30% of lead ship cost and 35-40% of follow ship costs.

Comparative analysis examines:

- all Basic Construction Cost Allocation (2-11)

**Combat Systems GFE Costs**

Symbol:  $C_{csgfe}$

Definition: Those costs related to Combat Systems Government Furnished Equipment (GFE). Includes costs for electronics

- all mobility in Ship Performance (1-3)
- drag at sustained speed (1-3)

### Prismatic Coefficient

Symbol:  $C_p$

Definition:  $C_p = V / (L_{bp} * \text{Area of maximum section at draft } T)$

The ratio of the bare hull volume of displacement to the volume of a cylinder having a length and a cross section equal in area to that of the maximum section at the designed waterline. This is considered to be a measure of the longitudinal distribution of a ship's displacement.[11] See figure F.2

Significance: If two ships with different prismatic coefficients have the same length and same displacements, the one with the smaller prismatic coefficient will have the larger midship sectional area which implies a concentration of the displacement midships. The ship with the larger coefficient will have a smaller midship sectional area with more "filled out" ends. Since this distribution of displacement influences the amount of residuary resistance at a given speed, powering will be affected by difference in prismatic coefficient.[10]

Expected Range [10]: 0.55 - 0.80

Comparative analysis examines:

- length between perpendiculars(1-1)

- beam at waterline (1-1)
- draft (1-1)

#### Maximum Section Coefficient

Symbol:  $C_x$

Definition:  $C_x = \text{Max transverse section area} / (B_{wl} * T)$

Ratio of the maximum transverse section area to the area of the circumscribing rectangle, the width of which is the waterline beam and the draft at that section.[10] See figure F.3.

Significance: Since this is a function of the "fullness" of the design, changes in the coefficient will affect powering, arrangeability and total enclosed volume, which will additionally drive displacement.

Expected Range: .69-.90 [10]

Comparative analysis examines:

- beam at waterline (1-1)
- draft (1-1)

#### Waterplane Coefficient

Symbol:  $C_{wp}$

Definition:  $C_{wp} = \text{Area of Waterplane} / L_{bp} * B_{wl}$

The ratio of the area of the waterplane to its circumscribing rectangle at the load waterline of the ship.[10]. See figure F.4

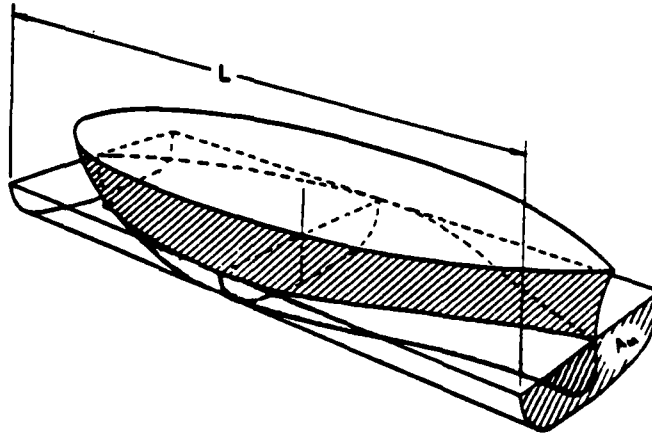

Figure F.2 Prismatic Coefficient

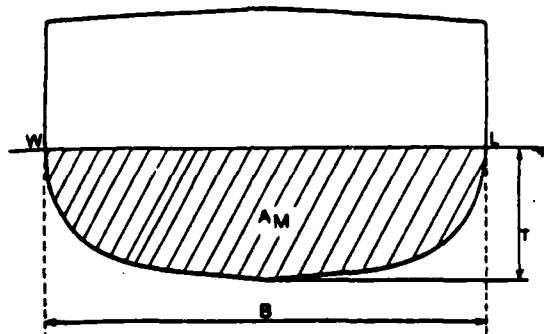

Figure F.3 Maximum Section Coefficient

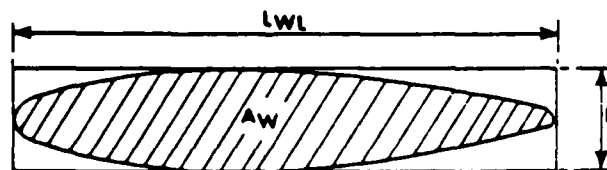

Figure F.4 Waterplane Coefficient

Significance: Changes will affect powering, resistance, and total enclosed volume, which will in turn drive displacement.

Expected Range: 0.67 - 0.87 [10]

Comparative analysis examines:

- beam at waterline (1-1)
- length between perpendiculars (1-1)

### Ratios of Dimensions

Definition: These dimensions are commonly used for comparisons as an expression of relative proportions of the ship form as numerical quantities.

Significance: All are impacted by their parent parameters and since all differences involve changes below the waterline, powering, resistance and total enclosed volume will be affected, which may affect displacement, arrangeability, and structural strength.

NOTE: Individual ratios, along with their respective symbols, expected range of values for monohull displacement ships and Comparative analysis paths are given below:

### Length to Beam Ratio

Symbol:  $L_{bp} / B_w$

Expected Range [24]: frigate 8.9 - 9.0  
destroyer 8.9 - 9.9 except DDG-51 @ 7.9  
cruiser 9.6 - 9.7

Comparative Analysis examines:

- length between perpendiculars (1-1)
- beam at waterline (1-1)

#### Length to Draft Ratio

Symbol:  $L_{bp} / T$

Expected Range [24]: frigate 27.5 - 28.3  
destroyer 23.3 - 28.2  
cruiser 24.5 - 27.9

Comparative analysis examines:

- length between perpendiculars (1-1)
- draft (1-1)

#### Beam to Draft Ratio

Symbol:  $B_{w1} / T$

Expected Range [24]: frigate 3.1 - 3.2  
destroyer 2.9 - 3.2  
cruiser 2.5 - 2.9

Comparative analysis examines:

- beam at waterline (1-1)
- draft (1-1)

#### Draft to Depth Ratio

Symbol:  $T / D$

Expected Range [24]: frigate .48 - .50  
destroyer .48 - .62

cruiser .49 - .51

Comparative analysis examines:

- draft (1-1)
- depth (1-1)

#### Length to Depth Ratio

Symbol:  $L_{bp} / D$

Expected Range [24,25]: frigate 14.7 - 15.0

destroyer 12.1 - 18.2

cruiser 13.5 - 14.1

Comparative analysis examines:

- length between perpendiculars (1-1)
- depth (1-1)

### SCREEN 1-3: SHIP PERFORMANCE

#### Mobility

Tabular data screen which relates the primary aspects of ship mobility regarding power, speed and range. These are each listed individually with the indices that impact or are impacted by that particular performance. Since these listings are tabular, symbols will not be required. Expected ranges are listed where appropriate.

#### Maximum Sustained Speed (80% power)

Definition: Based on the speed-power curve, the maximum speed (knots) obtainable at 80% maximum continuous shaft

horsepower, in calm water at full load weight and 100°F temperature.[17] Maximum sustained speed is determined at 80% horsepower to reflect the effect of fouling, sea conditions and propulsion plant degradation. It should be noted that other countries calculate maximum speeds at 100% horsepower and a trial displacement with only partial loads onboard. The speed-power curve can be determined analytically or experimentally and contains a power margin of approximately 10%. This curve is shown in figure F.5.

Significance: A difference in design speed can be attributed to either a change in the propulsion plant power available or in hull efficiency.

Expected Range [25]: frigates 27 - 29 Knots  
destroyers 30 - 34 Knots  
cruisers 30 - 33 Knots

Comparative analysis examines:

- shaft horsepower available (1-3)
- all Hull Efficiency of Ship Performance Screen (1-3)
- all size characteristics (1-1)
- all shape characteristics (1-2)
- Full Load Machinery Weight (2-3)
- Machinery Functional Allocation volume (2-6)
- Machinery Electrical Allocation fraction (2-8)
- Engineering Manning Allocation fraction (2-10)
- Machinery Cost Allocation fraction (2-12)

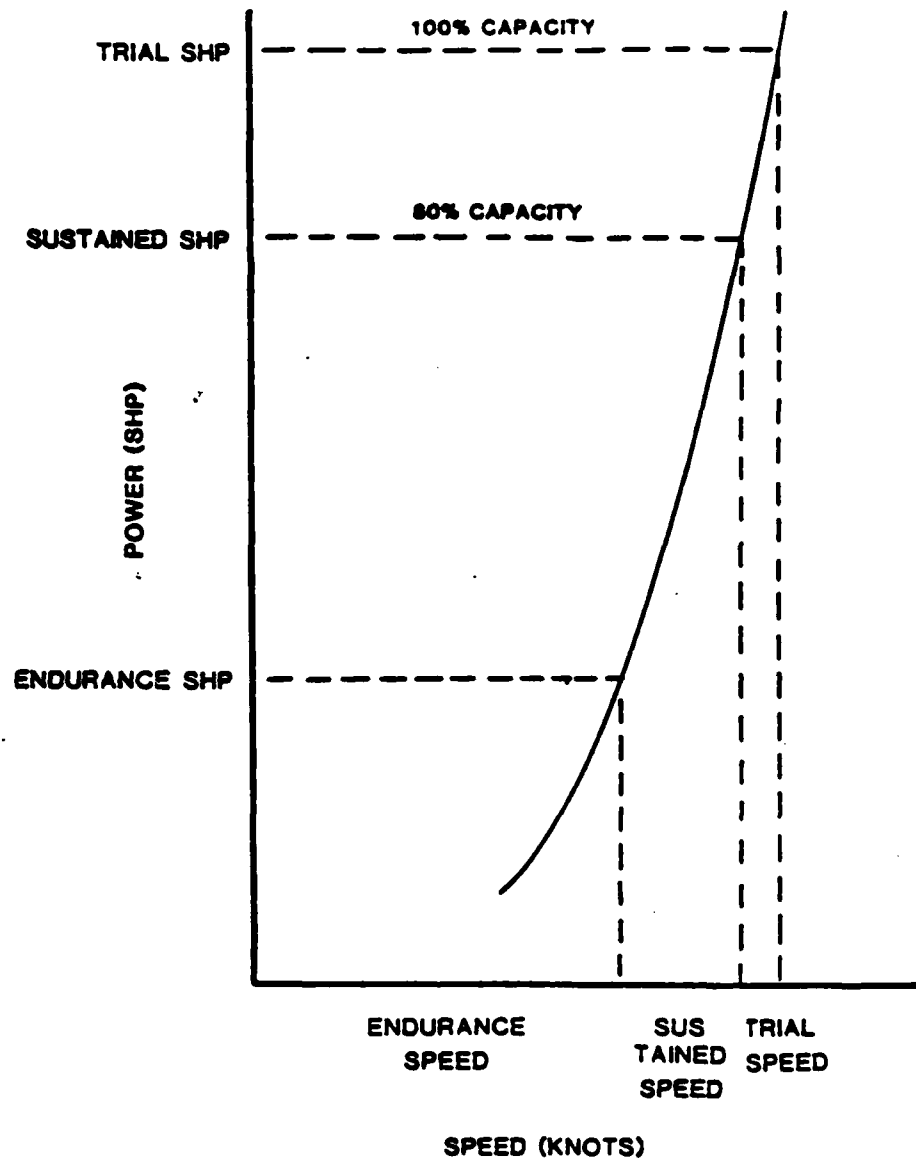

Figure F.5 Speed-Power Curve

### Maximum Trial Speed (100% power)

Definition: Based on the speed-power curve, the maximum speed (knots) obtainable at 100% installed (available) shaft horsepower, in calm water at full load weight and 100°F temperature.[17] See also definition for maximum sustained speed above.

Significance: A difference in trial speed can be attributed to either a change in the propulsion plant power available or in hull efficiency.

Expected Range [25]: frigates 27 - 29 knots  
destroyers 30 - 34 knots  
cruisers 30 - 33 knots

Comparative analysis examines:

- shaft horsepower available (1-3)
- all Hull Efficiency of Ship Performance Screen (1-3)
- all size characteristics (1-1)
- all shape characteristics (1-2)
- Full Load Machinery Weight (2-3)
- Machinery Functional Allocation volume (2-6)
- Machinery Electrical Allocation fraction (2-8)
- Engineering Manning Allocation fraction (2-10)
- Machinery Cost Allocation fraction (2-12)

### **Range at Endurance Speed**

**Definition:** The theoretical maximum distance of travel in nautical miles utilizing all of its burnable fuel, at a specified endurance speed, and ambient conditions of 100°F and 40% humidity, in deep water at full load displacement, as calculated in the Design Data Sheet, reference (18).

**Significance:** Changes in range impacts fuel requirement, which directly impacts liquids weight and volume. Range may also change if the hull size or efficiency has changed, thereby requiring a powering change.

**Comparative analysis examines:**

- all Hull Efficiency of Ship Performance Screen (1-3)
- Full Load Machinery Weight (2-3)
- Machinery Functional Allocation volume (2-6)
- Machinery Electrical Allocation fraction (2-8)
- Engineering Manning Allocation fraction (2-10)
- Machinery Cost Allocation fraction (2-12)

### **Endurance Period**

**Definition:** The length of time, in days, that the ship can remain underway without replenishment. A function of the four subcategories that are examined independently:

- \* fuel at endurance speed
- \* dry stores
- \* chilled stores

\* frozen stores

Significance: Period due to fuel may change as the amount of fuel carried or endurance speed is changed. Stores are generally fixed by the amount that the ship is designed to carry in its storerooms.

Comparative analysis examines:

- all Mobility of Ship Performance Screen (1-3)
- all Hull Efficiency of Ship Performance Screen (1-3)
- Full Load Machinery Weight (2-3)
- Machinery Functional Allocation volume (2-6)
- Machinery Electrical Allocation fraction (2-8)
- Engineering Manning Allocation fraction (2-10)
- Machinery Cost Allocation fraction (2-12)

#### Shaft Horsepower Available

Definition: Available power to be delivered into the water by the propeller. As defined in reference (17), shaft power is a function of the ship total effective power divided by the propulsive coefficient. This includes transmission and propeller losses and is calculated for the total power available from boost and cruise engines together at ambient conditions of 100°F and 40% humidity.

Significance: Power is needed to overcome ship drag (resistance). Differences directly affect maximum speed, propulsion weight and ship mobility volume.

**Comparative analysis examines:**

- Maximum Sustained Speed (1-3)
- Boost Engine Type/Number/Rating (1-4)
- Cruise Engine Type/Number/Rating (1-4)
- Machinery Functional Allocation volume (2-6)
- Machinery Electrical Allocation fraction (2-8)
- Engineering Manning Allocation fraction (2-10)
- Machinery Cost Allocation fraction (2-12)

#### **Shaft Horsepower Required at Endurance Speed**

**Definition:** Using the procedure discussed above and detailed in reference (17), a speed-power plot, shown in figure F.5 is obtained for the shaft horsepower of the ship. This plot includes standard speed-power margin policy set by NAVSEA and is dependent on the stage of design.[17] The shaft horsepower required at the desired endurance speed is obtained from this curve. It is noted that other countries do not use large power margins during early stage design which may result in an inequitable comparison between U.S. and foreign ships.

**Significance:** A change in the required SHP may result in a change in the size of engines required to limit the amount of engines on-line at endurance speed. It may additionally affect efficiency of the engine at endurance

speed, which will directly affect range or fuel requirements.

Comparative analysis examines:

- Range at Endurance Speed (1-3)
- Full Load Machinery Weight (2-3)
- Machinery Functional Allocation volume (2-6)
- Machinery Electrical Allocation fraction (2-8)
- Engineering Manning Allocation fraction (2-10)
- Machinery Cost Allocation fraction (2-12)

#### Shaft Horsepower Required at Sustained Speed

Definition: Based upon the speed-power curve, discussed above, this is the shaft power required to make the maximum sustained speed.[17]

Significance: A change in the shaft horsepower required may result in a change in the number of engines required thus resulting in a propulsion weight and ship mobility volume change. The shaft horsepower available must be equal to 1.25 times the shaft horsepower required at sustained speed.

Comparative analysis examines:

- Maximum Sustained Speed (1-3)
- Full Load Machinery Weight (2-3)
- Machinery Functional Allocation volume (2-6)
- Machinery Electrical Allocation fraction (2-8)
- Engineering Manning Allocation fraction (2-10)

- Machinery Cost Allocation fraction (2-12)

### Hull Efficiency:

#### Drag (sustained speed)

Symbol:  $R_{Ts}$

Definition: The fluid force (water and air) acting on the ship in such a way as to oppose its motion. Another term generally used is resistance[11]. As defined in reference (17), sustained speed drag or resistance is the sum of the totals of the frictional resistance, residuary resistance, appendage resistance, and still-air drag at defined sustained speed and full load weight.

Significance: Drag is directly affected by the ship size and shape parameters. In general, for a fixed displacement, an increase in ship length, a decrease in beam or an increase in draft will decrease the ships resistance[10]. These in turn, affect the shape parameters directly, thereby indirectly affecting the powering, structural aspects and arrangeability of the ship.

Comparative analysis examines:

- all Size Characteristics (1-1)
- all Shape Characteristics (1-2)

#### Drag (endurance speed)

Symbol:  $R_{Te}$

given thrust, speed of advance and propeller revolutions at endurance speed.[10].

Significance: Function of the selected propeller for the design. An increase in efficiency may result in an improved sustained or trial speed, as well as the horsepower required to achieve them.

Comparative analysis examines:

- all mobility of Ship Performance Screen (1-3)

#### Propulsion Coefficient

Definition: Ratio of effective horsepower to delivered horsepower[10]. More rigidly defined as a function of the Taylor wake fraction, thrust deduction fraction, propeller open water efficiency and relative rotative efficiency[17].

Significance: Since hull-propeller interaction is a major factor in the associated wake and thrust fractions, the parameter is affected by the hull. A change in the parameter will affect speed directly and may affect range and fuel requirements indirectly.

Comparative analysis examines:

- All ship size characteristics (1-1)
- All mobility of ship performance screen (1-3)
- Full Load Machinery Weight fraction (2-3)
- Tankage Volume fraction (2-5)

- Max Sustained Speed (1-3)
- Range at Endurance Speed (1-3)
- Full Load Machinery Weight fraction (2-3)
- Tankage Volume fraction (2-5)
- Machinery Electrical Energy Allocation fraction (2-7)
- Machinery Functional Allocation Cost fraction (2-11)

**Propeller Open Water Efficiency (sustained speed)**

Definition: The ratio between the power developed by the thrust of the propeller and the power absorbed by the propeller when operating in open water with uniform inflow velocity[17]. A function of the propeller torque at a given thrust, speed of advance and propeller revolutions at sustained speed.[10].

Significance: Function of the selected propeller for the design. An increase in efficiency may result in an improved sustained or trial speed, as well as a decrease in the horsepower required to achieve them.

Comparative analysis examines:

- all mobility of Ship Performance Screen (1-3)

**Propeller Open Water Efficiency (endurance speed)**

Definition: The ratio between the power developed by the thrust of the propeller and the power absorbed by the propeller when operating in open water with uniform inflow velocity[17]. A function of the propeller torque at a

propeller shaft. Electrical (AC/AC, AC/DC, etc) or mechanical (LTDR, Epicyclic, etc)

Significance: A change in transmission type will affect all propulsion weight and volume related factors and may affect structure or energy, especially if a change is made from electrical to mechanical or vice versa.

Comparative analysis examines:

- Full Load Machinery Weight fraction (2-3)
- Light Ship Machinery Weight fraction (2-3)
- Machinery Functional Allocation Volume fraction (2-6)
- Machinery Electrical Energy Allocation fraction (2-8)
- Engineering Manning Allocation fraction (2-10)
- Machinery Functional Allocation Cost fraction (2-12)

#### Propeller Type/No./RPM

Definition: Number and type of propeller (CRP, fixed pitch, contra-rotating) and its associated maximum RPM at trial speed (100% power).

Significance: Change in propeller type and RPM will directly affect powering, thereby affecting speed, range, fuel and noise requirements. A change in fuel requirements may then indirectly affect volume and weight in the mobility area.

Comparative analysis examines:

- Max Trial Speed (1-3)

provide better fuel economy. This parameter provides information as to the type, number and continuous maximum horsepower rating of the secondary engines. These engines are additionally used during boost applications.

**Significance:** An upgrade in cruise engines will directly affect weight and volume requirements by increasing machinery but decreasing fuel. Since these engines are used primarily for endurance calculations, a change may additionally account for differences in either fuel required or ships range.

**Comparative analysis examines:**

- Range at Endurance Speed (1-3)
- Full Load Machinery Weight fraction (2-3)
- Light Ship Machinery Weight fraction (2-3)
- Machinery Functional Allocation Volume fraction (2-6)
- Tankage Volume Allocation fraction (2-5)
- All Installed Hp Energy Allocation (2-8)
- All Fuel Usage Energy Allocation (2-8)
- Machinery Energy Allocation fraction (2-8)
- Engineering Manning Allocation fraction (2-10)
- Machinery Functional Allocation Cost fraction (2-12)

#### **Transmission System Type**

**Definition:** Specifies the type of transmission system used to deliver propulsion power from the engines to the

### **Boost Engine Type/Number/Rating**

**Definition:** Installed number and type of boost (or main) engines (Gas Turbine, Diesel, Steam, etc.) and associated maximum continuous horsepower rating at 100% per engine. Boost engines are those that are required to achieve maximum speed. In the case, where no cruise engines exist, boost engines are used at all speeds.

**Significance:** A change in type or number will directly affect weight and volume requirements, and may indirectly affect manning and energy. A change in rating will additionally affect ships powering and fuel requirements.

**Comparative analysis examines:**

- Full Load Machinery Weight fraction (2-3)
- Light Ship Machinery Weight fraction (2-3)
- Machinery Functional Allocation Volume fraction (2-6)
- Tankage Volume fraction (2-5)
- All Installed Hp Energy Allocation (2-8)
- All Fuel Usage Energy Allocation (2-8)
- Machinery Energy Allocation fraction (2-8)
- Engineering Manning Allocation fraction (2-10)
- Machinery Functional Allocation Cost fraction (2-12)

### **Cruise Engine Type/Number/Rating**

**Definition:** If installed, the cruise (or secondary) engine is used to provide cruise power at endurance speed to

Each indice and parameter selected to describe the various subsystems is defined below.

### Main Propulsion

#### Total Boost Power Avail/Reqd at Sustained Speed/Growth Potential

Definition: Total Propulsion horsepower available as compared to that required at sustained speed (80% power). The difference between required and available is the propulsion growth potential.

Significance: To get more available, the number of engines or size must change, and the number required is a function of the required speed and the hull efficiency. A significant change or difference will affect weight and volume, as well as manning and energy.

Comparative analysis examines:

- Full Load Machinery Weight fraction (2-3)
- Light Ship Machinery Weight fraction (2-3)
- Machinery Functional Allocation Volume fraction (2-6)
- Tankage Volume fraction (2-5)
- All Installed Hp Energy Allocation (2-8)
- All Fuel Usage Energy Allocation (2-8)
- Machinery Energy Allocation fraction (2-8)
- Engineering Manning Allocation fraction (2-10)
- Machinery Functional Allocation Cost fraction (2-12)

Significance: By canting the sides of the hull and the superstructure, the weight and volume are increased due to unused volume addition for the flare.

Comparative analysis examines:

- all ship size characteristics (1-1)
- all functional weight allocation fractions (2-3)
- all functional volume allocation fractions (2-6)

#### SCREEN 1.4: HM&E SYSTEM SELECTION

The area of system selection offers one of the largest opportunities for comparative assessment of different HM&E subsystems. By use of synthesis models, such as ASSET and DD08, a baseline ship is easily varied. The variant may be formed using either new technology or a simple subsystem change and the results stored in the data base and then directly examined without ever leaving the computer terminal. This provides one of the greatest strengths of accessing a comparative naval architecture module directly from within a synthesis program.

The subsystems and their associated direct impact values of interest to the designer are listed on this screen and compared between the selected baseline and variant design. Differences will be highlighted using reverse video and impacts may be assessed directly by the designer or indirectly by using the comparative analysis option.

None = no IR suppressors installed

Normal = DD963 type suppression installed

Decreased = Better suppression than DD963

Significance: Increased protection requires the addition of stack gas heat suppression or IR shielding techniques. These will affect weight and volume characteristics directly and may affect energy and manning indirectly.

Comparative analysis examines:

- all ship size characteristics (1-1)
- all functional weight allocation fractions (2-3)
- all functional volume allocation fractions (2-6)
- all energy functional allocation fractions (2-8)

#### Radar Signature

Definition: Protection designed into the ship to decrease the radar cross-section as seen by another radar looking at the ship being designed. This can be done by removing such reflection enhancers as "right angles" thus canting the sides to other than an orthogonal angle. The only U.S. Navy ship to be designed for radar signature reduction is the DDG51, it is therefore recommended that the following measurement be used.

Normal = no radar signature reduction

Reduced = equivalent to DDG51

Stealth = less signature than DDG51

Normal = less than DD-963

Quiet = DD-963 comparable

Silent = quieter than DD-963

Significance: Noise may be reduced by the incorporation of inherently quiet equipment and increased use of noise suppression mounts on "noisy" equipment to keep the noise from being radiated to the sea through the hull. Prairie and Masker systems may be provided to suppress hull and propeller noise. All these systems result in increased weight and volume of equipment, as well as size and weight of foundations.

Comparative analysis examines:

- all ship size characteristics (1-1)
- all functional weight allocation fractions (2-3)
- all functional volume allocation fractions (2-6)
- all energy functional allocation fractions (2-8)

#### IR Signature

Definition: That protection designed into the ship to protect it against infra-red detection and decrease the capability of infra-red target acquisition by enemy missiles. Since no basis for measurement is presently available, it is recommended that the following be used to specify an improved signature:

contamination from entering the ship, thus protecting the crew. The recommended unit of measure is classified by:

austere = masks, clothing, decon equip

parcps = partial cps

fulcps = full cps

**Significance:** A full or partial cps system may result in all areas of the design being affected, from the energy required to power the extra required equipment to the volume required to store them. Therefore, all primary groups must be examined for differences and then analyzed further by the user.

**Comparative analysis examines:**

- all ship size characteristics (1-1)
- all functional weight allocation fractions (2-3)
- all functional volume allocation fractions (2-6)
- all energy functional allocation fractions (2-8)

#### **Noise signature**

**Definition:** The noise radiated by the ship with which it may be detected either by another surface ship sonar or a submarine sonar. Additionally, the own ships radiated noise affects its own sonar capabilities. Since the relative quieting of the DD-963 is well understood by most designers, the following are recommended classifications:

adequate protection is provided, the ship may experience a "cheap kill" due to damaged vital equipment which received no direct hit. Recommended unit of measure is the Navy standard keel shock factor (KSF), which is explained in detail in reference (27).

Significance: Increased protection against shock requires proper mounting of equipment adding weight in foundations and equipment shock strengthening, thereby resulting in an increase in equipments of SWBS groups 2,3,4,5, and 7. Most new combatant type ships are designed to a 0.3 KSF standard.

Comparative analysis examines:

- All SWBS Weight Fractions (2-1)

#### NBC

Definition: That protection designed into the ship to protect the crew against nuclear, biological and chemical warfare contamination. These may be as simple as providing masks, clothing and decontamination equipment at the low end to providing full collective protection by pressurizing the interior of the ship and filtering all incoming air. A partial collective protection system is obtained by not including the main engine spaces in the protected subdivided areas. This prevents the

- structural cost fractions (2-11)

### Fragmentation

Definition: That protection designed into the ship to protect its vital combat and HM&E system areas against the "cheap kill" of destroying the capability of the ships mission with metal fragments. General method of classification is by using Levels, where the higher, the level, the greater the protection. Individual spaces may have different levels of protection. Since a program of this type cannot address each space individually, the dominant level in vital spaces will be used for this analysis. Protection levels are defined in reference (26).

Significance: Providing fragmentation protection implies locating vital spaces in inherently protected areas of the ship and/or armoring of vital spaces with increased structure. The latter will affect the structural weight fraction of the ship directly and may affect stability indirectly.

Comparative analysis examines:

- structural weight fractions (2-3)
- structural cost fractions (2-11)

### Shock

Definition: That protection designed into the ship to protect it against underwater shock effects. Unless

Comparative analysis examines:

- all size characteristics (1-1)
- all shape characteristics (1-2)

### Survivability

The exact method of categorizing the different classifications for survivability indices will be dependent on the synthesis model or data base in use. The impacts of the changes, however, are assessed in the same manner by comparing changes in weight, volume, size, machinery and cost. The trend in recent designs has been to provide increased survivability to the ships, when cost feasible.

Definitions and recommended methods of classification and quantification are discussed with each category.

### Blast

Definition: That protection designed into the ship to protect it against the effect of nuclear blast. The general classification is in pounds per square inch (psi) blast overpressure, where the greater the value, the better the protection.

Significance: The protection against blast requires increased structural protection, by either going to a stronger or thicker steel, thus increasing the structural weight fraction directly.

Comparative analysis examines:

- structural weight fractions (2-3)

Definition: Ships resistance at endurance speed as defined above.

Significance: Same as for sustained speed drag above.

Comparative analysis examines:

- all Size Characteristics (1-1)
- all Shape Characteristics (1-2)

#### **Bales Rank**

Definition: A seakeeping figure of merit relating ship hull geometry to seakeeping characteristics of destroyer type hulls in long-crested, head seas. Based on empirical type data, the rank coefficients range from zero to ten, with ten being the optimum rank. The initial work and the parameters used along with a detailed explanation may be found in reference (19). An extension to the regression theory, which includes a displacement factor is introduced in reference (20).

Significance: In context with the indices used in this analysis, seakeeping is projected to improve with increasing waterplane area coefficient, or decreasing draft to length ratio (increasing length to draft ratio)[19].

Expected Range: Vary in range from 0 to 10 and may exceed 10. A hull with a rank of 7.5 or better is considered to be a very good seakeeping hull.[19]

- Machinery Electrical Energy Allocation fraction (2-8)
- Machinery Allocation Cost fraction (2-12)

#### Specific Fuel Consumption Rate @ Endurance Speed

Symbol:  $SFC_e$

Definition: The specific fuel rate in lb/SHP-hr based on the total fuel consumption for propulsion machinery only when operating at the specified endurance speed, at ambient 100°F and 40% humidity.[18]

Significance: SFC changes with horsepower output and most engines run more efficiently with a lower SFC at higher horsepower. If the endurance speed SFC changes, the range and/or the fuel load carried will be directly affected.

Comparative analysis examines:

- Range at endurance speed (1-3)
- Endurance Period due to Fuel (1-3)
- Tankage Volume fraction (2-5)
- Full load Machinery Weight fraction (2-3)

#### Specific Fuel Consumption Rate @ Sustained Speed

Symbol:  $SFC_s$

Definition: The specific fuel rate in lb/SHP-hr based on the total fuel consumption for propulsion machinery only when operating at the specified sustained speed, at ambient 100°F and 40% humidity.[18]

Significance: SFC changes with horsepower output and most engines run more efficiently with a lower SFC at higher horsepower.

Comparative analysis examines:

- Max Sustained Speed (1-3)
- Full load Machinery Weight fraction (2-3)

#### Other

Definition: Comment array to allow user to input manually any other systems that he feel significant under this heading. Items input into this category will display only and will have no impact on Comparative analysis. Recommend that array be one column and 10 rows, of which any portion may be accessed.

#### Electric Power

##### Total 60Hz KW Available/Maximum Load/Growth Potential

Definition: The sum of the total 60Hz generation capacity available for use as compared to the actual maximum functional load. The growth potential in this case is the difference between the two. The Navy requirement is that a minimum of one generator be available as "standby".[16]

Significance: An increase in load or a decrease in available KW may result in the inability to meet the demand of a "standby" generator, thus necessitating the addition of

another generator or the increased size of the available number, which will directly impact weight and volume and may impact manning in the electrical and mobility area.

Comparative analysis examines:

- Electrical Weight fraction (2-1)
- Machinery Volume Allocation fraction (2-6)
- All Electrical Energy Allocation fractions (2-7)
- Fuel Usage Energy Allocation fraction (2-8)
- Engineering Manning Allocation fraction (2-10)
- Electrical Allocation Cost fraction (2-11)

#### Total 400 Hz KW Available/Maximum Load/Growth Potential

Definition: The sum of the total 400 Hz conversion capacity available for use as compared to the actual 400 Hz maximum functional load. The margin is the difference between the two. The Navy requirement is that a minimum of one converter to be available as a "standby".[16]

Significance: An increase in load or a decrease in available KW may result in the inability to meet the demand of a "standby" 400 Hz converter, thus necessitating the addition of another 400 Hz converter on the ship, which will directly impact weight and volume and may impact manning in the electrical and mobility area. An additional impact is that since in most cases, the 400Hz converter

draws its power from one of the 60Hz generators, there may be an effect in the 60 Hz area.

Comparative analysis examines:

- Total 60 Hz KW available/maximum load/margin (1-4)
- Electrical Weight fraction (2-1)
- Machinery Volume Allocation fraction (2-6)
- All Electrical Energy Allocation fractions (2-7)
- Fuel Usage Energy Allocation fraction (2-8)
- Engineering Manning Allocation fraction (2-10)
- Electrical Allocation Cost fraction (2-11)

#### **60 Hz Generator Type/Number/Rating**

Definition: Number and type of installed 60 Hz generators (Gas Turbine, Diesel, etc.) and individual "maximum continuous available KW" rating.

Significance: A minimum of three generators are required on surface combatants. All generators must be of the same rating. A change in this parameter will affect electrical weight, volume and electrical margin related indices directly, and may affect manning indirectly.

Comparative analysis examines:

- Electrical Weight fraction (2-1)
- Machinery Volume Allocation fraction (2-6)
- All Electrical Energy Allocation fractions (2-7)
- Fuel Usage Energy Allocation fraction (2-8)

- Engineering Manning Allocation fraction (2-10)
- Electrical Allocation Cost fraction (2-11)

#### 400 Hz Generator Type/Number/Rating

**Definition:** Number and type of installed 400 Hz generators or converters and individual "maximum available KW" rating.

**Significance:** A change in this parameter will affect electrical weight and volume related indices directly, and may affect manning indirectly. Older ships tend to still use the motor-generator type converter, whereas the newer ships and all future ships use the solid-state static converters.

**Comparative analysis examines:**

- Electrical Weight fraction (2-1)
- Machinery Volume Allocation fraction (2-6)
- Fuel Usage Energy Allocation fraction (2-8)
- Engineering Manning Allocation fraction (2-10)
- Electrical Allocation Cost fraction (2-11)

#### Specific Fuel Consumption (electrical)

**Symbol:** SFCA

**Definition:** The specific fuel rate in lb/Hp-hr based on the total fuel consumption for the electric generators only at an average 24 hour electric load in KW at ambient 100of and 40% humidity.[18]

**Significance:** A change in electrical SFC will directly affect the amount of fuel needed to meet the required endurance range.

**Comparative analysis examines:**

- Range at endurance speed (1-3)
- Tankage Volume fraction (2-5)
- Full Load Machinery Weight fraction (2-4)
- Fuel Usage Energy Allocation fraction (2-8)

#### **Other**

**Definition:** Comment array to allow user to input manually any other systems that he feel significant under this heading. Items input into this category will display only and will have no impact on Comparative analysis. Recommend that array be one column and 10 rows, of which any portion may be accessed.

#### **Auxiliary**

##### **Total AC Available/Maximum Load/Growth Potential**

**Definition:** Air conditioning is provided for the comfort of the crew and the protection of the vital electronics equipment and includes both temperature and humidity control. Total AC available and maximum load are rated in "tons" of cooling capacity and are based on the total

number of units available. The growth potential is the difference between available and required.

**Significance:** The extent of temperature and humidity control required drives the parameter, directly affecting weight, volume and energy. These affects may not only be in the area of installing extra or larger units, but also in specific spaces where additional weight and volume are required for the ducting and fan rooms. Indirect affects may include manning. This may drive the design choice to not cool some spaces where cooling was initially desired. AC plants have continuously grown in size over the last 40 years.

**Comparative analysis examines:**

- AC Type/No./Rating (1-4)
- Auxiliary Systems Weight fraction (2-1)
- Light Ship Containment Weight fraction (2-3)
- All Functional Volume Allocation fractions (2-6)
- Machinery Electrical Energy Allocation fraction (2-8)
- Engineering Manning Allocation fraction (2-10)
- Auxiliary Systems Allocation Cost fraction (2-11)

**AC Type/No./Rating**

**Definition:** Specifies the type and number of AC units, as well as the rating in tons of cooling capacity of each.

Significance: Size and number vary with the functional equipment cooling load, growth margins, redundancy and plant rating. Impacts are as described in parameter above.

Comparative analysis examines:

- Total AC Available/Max Load/Margin (1-3)
- Auxiliary Systems Weight fraction (2-1)
- Light Ship Containment Weight fraction (2-3)
- All Functional Volume Allocation fractions (2-6)
- Machinery Electrical Energy Allocation fraction (2-8)
- Engineering Manning Allocation fraction (2-10)
- Auxiliary Systems Allocation Cost fraction (2-11)

#### Heating Type/Rating

Definition: Predominant form of heating used on the ship as steam or electric. Rating would be electric power required per unit in KW for electric and steam pressure required per unit in psi for steam.[21]

Significance: The greatest impact results in the area of energy usage depending on whether the system uses steam or electric coils as the heat source. If electric heating is used, the winter daily energy load may vary considerably. The type of heater has little impact on volume or weight.

Comparative analysis examines:

- Auxiliary Weight fraction (2-1)

- Machinery Volume Allocation fraction (2-6)
- Machinery Electrical Energy Allocation fraction (2-8)
- Auxiliary Systems Allocation Cost fraction (2-11)

#### **Firepump Type/No./Rating**

Definition: Number and type of firepumps installed rated by gallons per minute (gpm).

Significance: Little effect on other systems but vital to damage control organization.

Comparative analysis examines:

- Auxiliary Weight fraction (2-1)
- Machinery Volume Allocation fraction (2-6)
- Machinery Electrical Energy Allocation fraction (2-8)
- Auxiliary Systems Allocation Cost fraction (2-11)

#### **Seawater Pump Type/No./Rating**

Definition: Number and type of seawater service pumps installed rated by gallons per minute (gpm).

Significance: Number required is a function of the type of other systems installed that require seawater cooling from the main cooling loop.

Comparative analysis examines:

- Auxiliary Weight fraction (2-1)
- Machinery Volume Allocation fraction (2-6)
- Machinery Electrical Energy Allocation fraction (2-8)
- Auxiliary Systems Allocation Cost fraction (2-11)

#### HP Air Compressor Type/No./Rating

Definition: Number and type of HP air compressors installed rated by cubic feet per minute air flow (cfm).

Significance: Dependent on the requirements for HP air. Gas turbine ships use HP air for starting purposes, which makes it a critical system for this type of propulsion plant. Other uses include torpedo and gun systems.

Comparative analysis examines:

- Boost Engine Type (1-4)
- Cruise Engine Type (1-4)
- Auxiliary Weight fraction (2-1)
- Machinery Volume Allocation fraction (2-6)
- Machinery Electrical Energy Allocation fraction (2-8)
- Auxiliary Systems Allocation Cost fraction (2-11)

#### LP Air Compressor Type/No./Rating

Definition: Number and type of LP air compressors installed rated in cubic feet per minute air flow (cfm).

Significance: Dependent on the requirements for LP air, which are fairly general and widespread for all combatants.

Comparative analysis examines:

- Auxiliary Weight fraction (2-1)
- Machinery Volume Allocation fraction (2-6)
- Machinery Electrical Energy Allocation fraction (2-8)

- Auxiliary Systems Allocation Cost fraction (2-11)

#### **Distilling Plant Type/No./Rating**

**Definition:** Number and type of Distilling Plants installed where the rating is in gallons of freshwater produced per day (gpd). Type should specify whether the system is steam or electric.

**Significance:** A critical system to crew support. As the ship size increases, the crew size may increase proportionally and the distillers must be sufficient to meet their daily need. Additionally, an electrical type system will draw a larger electrical load.

**Comparative analysis examines:**

- Manning Total Complement (1-4)
- Auxiliary Weight fraction (2-1)
- Machinery Volume Allocation fraction (2-6)
- Machinery Electrical Energy Allocation fraction (2-8)
- Auxiliary Systems Allocation Cost fraction (2-11)

#### **Boats Type/No.**

**Definition:** Specifies the number and types of ships boats carried onboard.

**Significance:** Boats require external area and provide weight in the superstructure area, as well as requiring mechanical handling equipment. The type and number of

boats will directly affect weight and energy but will have little effect on internal volume.

Comparative analysis examines:

- Auxiliary Weight fraction (2-1)
- Machinery Volume Allocation fraction (2-6)
- Machinery Electrical Energy Allocation fraction (2-8)
- Auxiliary Systems Allocation Cost fraction (2-11)

#### Steering Units Type/No.

Definition: Specifies the number and type of steering units installed onboard the design.

Significance: Steering units require volume and are inherently very heavy, thus affecting weight and volume parameters directly. Indirect effects may include manning and energy considerations.

Comparative analysis examines:

- Auxiliary Weight fraction (2-1)
- Machinery Volume Allocation fraction (2-6)
- Machinery Electrical Energy Allocation fraction (2-8)
- Engineering Manning Allocation fraction (2-10)
- Auxiliary Systems Allocation Cost fraction (2-11)

#### Anchors Type/No./Length of Chain

Definition: Specifies the number and type of anchors installed, as well as the total length of chain carried aboard.

Significance: Anchors require a large amount of chain. Installation of an additional anchor or possibly a heavier anchor will directly affect weight and volume by requiring a chain locker and having to store the chain. Additional requirements may be in the form of energy for an upgraded or additional anchor windlass.

Comparative analysis examines:

- Auxiliary Weight fraction (2-1)
- Full Load Machinery Weight fraction (2-3)
- Machinery Volume Allocation fraction (2-6)
- Machinery Electrical Energy Allocation fraction (2-8)
- Auxiliary Systems Allocation Cost fraction (2-11)

#### UNREP Capability

Definition: Specifies type of underway replenishment capability installed or "none". Older ships have fixed padeyes and miscellaneous handling equipment. Newer combatants (FFG-7, DD-963, etc) have the STREAM (Standard Tensioned Replenishment Alongside Method) system.[16]

Significance: Underway replenishment capability requires deck space for receiving and mechanical handling equipment which may affect energy directly if an automated system is used. Although, external area is required, internal volume and weight impact are not expected to be too great, but should be checked at Comparative analysis anyway.

Comparative analysis examines:

- Auxiliary Weight fraction (2-1)
- Machinery Volume Allocation fraction (2-6)
- Machinery Electrical Energy Allocation fraction (2-8)
- Auxiliary Systems Allocation Cost fraction (2-11)

#### Other

Definition: Comment array to allow user to input manually any other systems that he feel significant under this heading. Items input into this category will display only and will have no impact on Comparative analysis. Recommend that array be one column and 10 rows, of which any portion may be accessed.

#### Structure/Materials

##### Hull Materials

Definition: Specifies the principal materials with which the hull is constructed. Since the hull may be constructed of more than one type of material, this information must be available to be stored in an array which will specify type of material and location of usage.

Significance: The type of material specifies the material properties which result in scantling sizing and weight calculations. Different types of materials will result in radically differing structural weights, which may

Expected Range[24]: light ship 35 - 53 %  
full load 24 - 40 %

Comparative analysis examines:

- Hull Structure Cost (2-11)
- All Structure Wt Breakdown Fractions (3-1)
- All  $W_1$  Related Containment Indices (3-2)

### Main Propulsion

Symbol:  $W_2/\Delta$

Definition: Main Propulsion weight fractions which includes all SWBS Group 2 weights listed in reference (22).

Significance:  $W_2/\Delta = (W_2/SHP) * (SHP/\Delta)$

Driven primarily by main propulsion specific weight and propulsion ship size ratio. Here the subsystem designer may be able to control the specific weight, however, the propulsion ship size ratio is driven by the ship requirements for speed or by the efficiency of the hull. Recent trends have shown a decrease in this fraction, primarily due to the shift to gas turbine propulsion instead of steam.

Expected Range[24]: light ship gas turbine 10 - 13 %  
light ship steam 15 - 26  
full load gas turbine 7 - 10  
full load steam 11 - 18

accordingly with the affected group increasing a given percentage. The sum of all other groups will then decrease that given percentage to maintain the 100% requirement. In the event that the variant has been affected in more than one SWBS group, the user will have to analyze the situation to the best of his ability. The comparative analysis option may help him in this regard.

Each screen indice is seperately addressed below.

General symbols:  $\Delta_{f1}$  = full load displacement

$\Delta_{1s}$  = light ship displacement

$\Delta$  = select either full load or

light ship displacement

### Structural

Symbol:  $W_1/\Delta$

Definition: Hull structural weight fraction, including all SWBS Group 1 weights as listed in reference (22).

Significance:  $W_1/\Delta = (W_1/\nabla) * (\nabla/\Delta)$

This fraction is largely driven by the total hull structure specific weight and the inverse of the ship density. It is therefore, extremely dependent on volume. It is affected by many variables, including length, volume, displacement, hull form, local loading, ship dimension ratios, penetrations, frame spacing and materials. The recent trend to increased ship volume has resulted in an upward trend in structural weight.

## LEVEL 2: RESOURCE ALLOCATION

This second level of comparative analysis further investigates related resource screens of level 2 to narrow down the effect on the resource, as well as looking at level 3 to find how any specific resource change or difference has affected the functional area of:

- containment
- main propulsion
- electrical
- auxiliary
- combat system
- human support

## SCREEN 2-1: SWBS WEIGHT FRACTIONS

This weight fraction is the relationship of the weight of the SWBS[22] group to the overall displacement weight either full load or light ship, as selected by the user. In many cases, this is the first check of where weight change has occurred due to a change in a HM&E system, combat system or ship integration approach. Further analysis using the comparative analysis option allows further investigation into the exact impact or cause of the weight change.

Since this is a fraction, the sum totals must always equal 100% and interpretation of change must be made by the user. As an example, the addition of weight in one SWBS area will also result in an overall displacement change. All fractions then change

**Significance:** The screen is set up to allow direct one-on-one comparison of combat systems for each area and subarea addressed above. Changes in the variant to the baseline ship are highlighted and can be selected for Comparative analysis. It is noted, however, that if more than one combat system is changed, the resultant impact analysis obtained is for the overall combat system change, not only for the one selected. To perform a single system impact analysis, the single system must be the only one changed on the variant with all other systems being identical in all other respects.

**Comparative analysis:** Since changes in a combat system may affect everything from displacement to energy and powering, all four subsystem categories of this screen are analysed using the same decision "branch" which checks for first order changes in the new variant.

- All Functional Weight fractions (2-3)
- All Functional Volume Allocation fractions (2-6)
- All Space Type/Location Volume fraction (2-5)
- All Functional Electrical Energy fractions (2-8)
- All Functional Manning Allocation fractions (2-10)
- All Functional Allocation Cost fractions (2-12)

Definition: Combat Systems are payload systems which are generally government supplied equipment. They are classified into one of three warfare areas and then further subdivided into a primary usage depending on the system. This may result in some systems being listed more than once. The three warfare areas listed are:

- Anti-Air Warfare (AAW)
- Anti-Submarine Warfare (ASW)
- Surface/Strike Warfare (SUW)
- Command, Control, Communications and Intelligence (C3I)

Where the first three are each subdivided into:

- Armament - all weapons related systems (guns, missiles)
- Sensors - all sensor related systems (search radars, fire control radars, EW systems)
- Aviation - all aviation related systems (helo & support)

The C3I warfare area is subdivided into:

- Command & Control - all command and control related systems
- Communications - all communications related systems
- Electronic Warfare - all electronic warfare systems

## Other

Definition: Comment array to allow user to input manually any other systems that he feel significant under this heading. Items input into this category will display only and will have no impact on Comparative analysis. Recommend that array be one column and 10 rows, of which any portion may be accessed.

### SCREEN 1-5: COMBAT SYSTEMS SELECTION

As in the HM&E system selection above, the ability to compare the whole ship impact of choosing an alternate combat system or group of combat systems in a real-time environment is extremely beneficial. A decision to update to a different combat system can be made directly from information obtained within a synthesis model or an existing data bank. This decision can be based on overall ship impact and not just on cost or weight analysis, as is often done. It must, however, be noted that this analysis examines only the ship impact of the alternate combat system as compared to the baseline and not the operational effectiveness of the combat system itself. It will provide information to compare both quality and quantity of combat systems. The assessment of quantity will be provided by the parameters such as the number and size of the missiles, whereas, the assessment of quality must come from the designers knowledge of the system.

**Comparative analysis examines:**

- Crew and Effects Load Weight fraction (2-2)
- Full Load Containment Weight fraction (2-3)
- Human Support Volume fraction (2-4)
- Containment Electrical Energy Allocation fraction (2-8)
- All Manning Allocation fraction (2-9)
- All Functional Allocation Cost fraction (2-12)

**Flag Configured**

**Definition:** Either "yes" or "no" indicating whether the ship is designed to carry a squadron or group commander with staff.

**Significance:** The addition of this capability will add approximately 8-10 officer and 2-4 enlisted manning requirements to the ship. This directly relates to human support weight, volume and energy requirements.

**Comparative analysis examines:**

- Crew and Effects Load Weight fraction (2-2)
- Full Load Containment Weight fraction (2-3)
- Human Support Volume fraction (2-4)
- Containment Electrical Energy Allocation fraction (2-8)
- All Manning Allocation fraction (2-9)
- All Functional Allocation Cost fraction (2-12)

enlisted. This is therefore impacted whenever a new or updated subsystem, which requires additional personnel, is added to the ship.

Comparative analysis examines:

- Crew and Effects Load Weight fraction (2-2)
- Full Load Containment Weight fraction (2-3)
- Human Support Volume fraction (2-4)
- Containment Electrical Energy Allocation fraction (2-8)
- All Manning Allocation fraction (2-9)
- All Functional Allocation Cost fraction (2-12)

#### Habitability Classification

Definition: Determines the amount of "Human Support" designed into the ship. Human support includes both environmental control and the actual facility area required for living, messing and recreation. A recommended classification is, as in the ASSET program[16], either "plush", "standard", or "austere". An example of "plush" would be the DD963 class destroyer, whereas the DDG2 class would be classified as "austere". Habitability standards are set by the Office of Naval Operations.

Significance: The level of classification has an obvious direct volume, weight, and energy impact on the overall ship.

personnel, including officer, CPO, and enlisted expected to be assigned to the ship. The growth potential is the difference between the two.

**Significance:** A larger number of accommodations impacts the ship by requiring more space and using more weight and energy. The margin may be required to allow for future weapons system addition.

**Comparative analysis examines:**

- Crew and Effects Load Weight fraction (2-2)
- Full Load Containment Weight fraction (2-3)
- Human Support Volume fraction (2-4)
- Containment Electrical Energy Allocation fraction (2-8)
- All Manning Allocation fraction (2-9)
- All Functional Allocation Cost fraction (2-12)

#### **Total Complement (OFF/CPO/ENL)**

**Definition:** The total complement of personnel; officer, chief petty officer and enlisted. Manning level is most often determined by ship requirements at Condition III, which is underway with selected elements of combat systems energized and still having the ability to perform maintenance and training.

**Significance:** Each unit of manning adds both weight and volume to the design directly and energy indirectly. Officers require more than CPO's, which require more than

Significance: Impacts arrangeable volume and area available.

Comparative analysis examines:

- All Space/Type Location Volume fractions (2-5)

#### Hull Average Deck Height

Definition: Total arrangeable volume divided by the comparable area.

Significance: Directly affects human support space available and impacts the crew.

Comparative analysis examines:

- Total Manning Complement (1-4)
- Structural Weight fraction (2-1)
- All Space/Type Location Volume fractions (2-5)

#### Other

Definition: Comment array to allow user to input manually any other systems that he feel significant under this heading. Items input into this category will display only and will have no impact on Comparative analysis. Recommend that array be one column and 10 rows, of which any portion may be accessed.

#### Manning

##### Total Accomodations/Total Complement/Growth Potential

Definition: Accomodations are the actual berths onboard for each rating. The complement is the total number of

## Deck Heights

### Number of Internal Decks in Hull

Definition: Number of decks and platforms below the main deck.

Significance: Impacts directly on the structural weight and the amount of arrangeable area available.

Comparative analysis examines:

- Total Manning Complement (1-4)
- Structural Weight fraction (2-1)
- All Space/Type Location Volume fractions (2-5)

### Number of Internal Decks in Deckhouse

Definition: Number of decks in the superstructure above the main deck.

Significance: Impacts on structural weight and arrangeable area available in the deckhouse.

Comparative analysis examines:

- Total Manning Complement (1-4)
- Structural Weight fraction (2-1)
- All Space/Type Location Volume fractions (2-5)

### Internal Deck Heights

Definition: Array which will hold the height of each deck, hull and deckhouse, as a function of height above baseline.

- All Functional Allocation Cost fractions (2-12)

#### Deckhouse Frame Type/Spacing

Definition: Specifies hull framing type (transverse or longitudinal) and frame spacing used in the deckhouse.

Significance: As with the hull framing, deckhouses are generally longitudinally framed to increase strength. Changing the spacing, again affects the weight of the superstructure directly. Other groups may be affected and must also be examined.

Comparative analysis examines:

- All Size Characteristics (1-1)
- All Functional Weight fractions (2-3)
- All Functional Volume Allocation fractions (2-6)
- All Electrical Energy Functional fractions (2-8)
- All Functional Manning Allocation fractions (2-10)
- All Functional Allocation Cost fractions (2-12)

#### Other

Definition: Comment array to allow user to input manually any other systems that he feel significant under this heading. Items input into this category will display only and will have no impact on Comparative analysis. Recommend that array be one column and 10 rows, of which any portion may be accessed.

- All Functional Weight fractions (2-3)
- All Functional Volume Allocation fractions (2-6)
- All Electrical Energy Functional fractions (2-8)
- All Functional Manning Allocation fractions (2-10)
- All Functional Allocation Cost fractions (2-12)

#### Hull Frame Type/Spacing

Definition: Specifies hull framing type (transverse or longitudinal) and frame spacing used in the hull.

Significance: Longitudinal framing is much superior to the transverse system in longitudinal strength[10] and is used in Naval combatants. Present designs use widely spaced longitudinals and web frames to reduce construction labor[13]. The effect of decreasing the spacing will result in increased structural weight. The important aspect of adequate structure is adequate hull strength. All primary characteristics should be examined for changes, since they may be indirectly affected by a frame spacing or a type of frame change.

Comparative analysis examines:

- All Size Characteristics (1-1)
- All Functional Weight fractions (2-3)
- All Functional Volume Allocation fractions (2-6)
- All Electrical Energy Functional fractions (2-8)
- All Functional Manning Allocation fractions (2-10)

indirectly affect all major groups of the ship design. All functional areas will, therefore, be examined in the Comparative analysis.

Comparative analysis examines:

- All Size Characteristics (1-1)
- All Functional Weight fractions (2-3)
- All Functional Volume Allocation fractions (2-6)
- All Electrical Energy Functional fractions (2-8)
- All Functional Manning Allocation fractions (2-10)
- All Functional Allocation Cost fractions (2-12)

#### Deckhouse Materials

Definition: Specifies the principal materials with which the deckhouse is constructed. Since it may be constructed of more than one type of material, the input must be an array that will allow the location and material to be specified.

Significance: The type of material specifies the material properties which result in scantling sizing and weight calculations. Different types of materials will result in radically differing structural weights, which may indirectly affect all major groups of the ship design. All functional areas will, therefore, be examined in the comparative analysis.

Comparative analysis examines:

- All Size Characteristics (1-1)

Comparative analysis examines:

- Propulsion Plant Cost (2-11)
- All Main Propulsion Weight Breakdown (3-3)
- All Weight Related Main Propulsion Indices (3-4)

#### Electrical

Symbol:  $W_3/\Delta$

Definition: Electrical weight fraction including all SWBS Group 3 weights of reference (22).

Significance:  $W_3/\Delta = (W_3/E_i) * (E_i/\Delta)$

Driven by electrical specific weight of installed power and electrical ship size ratio. The recent increasing trend is due to the increased installed KW/ton for the combat systems and the change from steam to gas turbine propulsion and steam to electrical auxiliaries.

Expected Range[24]: light ship gas turbine 5 - 7 %  
light ship steam plant 4 - 5  
full load gas turbine 4 - 5  
full load steam plant 3 - 4

Comparative analysis examines:

- Electric Plant Costs (2-11)
- All Electric Plant Weight Breakdown (3-5)
- All Weight Related Electrical Indices (3-6)

#### Command and Surveillance

Symbol:  $W_4/\Delta$

Definition: Command and Surveillance Weight fraction including all SWBS Group 4 weights as listed in reference (22).

Significance:  $W_4/\Delta = (W_4/\#snsr) * (\#snsr/\Delta)$

Driven by the command and surveillance specific weight and capacity size ratio. This group includes all sensor and radar systems, including fire control. The recent increasing trend is due to the higher emphasis on radar, sonar and countermeasures.

Expected Range[24]: light ship 3 - 10 %  
full load 3 - 7

Comparative analysis examines:

- Combat Systems Cost (2-12)
- All Combat System Weight Fractions (3-9)
- All C&S Weight Fractions (3-9)
- All C&S Related Combat System Indices (3-10)

#### Auxiliary Systems

Symbol:  $W_5/\Delta$

Definition: Auxiliary Systems weight fraction, including all SWBS Group 5 weights as listed in reference (22).

Significance:  $W_5/\Delta = (W_5/V) * (V/\Delta)$

Driven by the auxiliary specific weight and ship specific volume. A function of the complexity of the auxiliary systems installed. The shift to gas turbine propulsion

and increased HVAC requirements for the combat systems and habitability has resulted in an increased  $W_5$  fraction.

Expected Range[24]: light ship 11 - 14 % except FFG-7 @ 18%  
full load 8 - 10 % except FFG-7 @ 13%

Comparative analysis examines:

- Auxiliary Systems Cost (2-11)
- All Auxiliary Weight Breakdown (3-7)
- All Auxiliary Indices (3-8)

#### Outfit and Furnishings

Symbol:  $W_6/\Delta$

Definition: Outfit and Furnishings weight fraction, including all SWBS Group 6 weights as listed in reference (22).

Significance:  $W_6/\Delta = (W_6/V) * (V/\Delta)$

Driven by auxiliary specific weight and ship specific volume. Since much of this weight group relates to human support, it is directly affected by the manning size and the type of habitability installed in the design. Since the trend has been to improve habitability, this fraction has shown an increase in recent years.

Expected range[24]: light ship 8 - 12 %  
full load 5 - 9 %

Comparative analysis examines:

- Outfit and Furnishings Cost (2-11)
- All Outfit and Furnishing Weight Breakdown (3-1)

- All  $W_g$  Related Containment Ratios (3-2)
- Human Support Specific Weight (3-12)
- Outfit and Furnishing Human Support Wt Fraction (3-11)

#### Armament

Symbol:  $W_7/\Delta$

Definition: Armament Weight fraction including all SWBS Group 7 weights as listed in reference (22).

Significance:  $W_7/\Delta = (W_7/\#1chr) * (\#1chr/\Delta)$

Driven by the armament specific weight and the capacity size ratio. Armament pertains to those actual systems that directly relate to weapons and its ammunition. Although the armament has actually increased in some recent designs, the weight has decreased due to the switch from heavy guns to lighter missiles.

Expected Range[24]: light ship 3 - 10 %

full load 3 - 7 %

Comparative analysis examines:

- Combat Systems Cost (2-12)
- All Combat System Weight Fractions (3-9)
- All Armament Weight Fractions (3-9)
- All Armament Related Combat System Indices (3-10)

#### Margin

Symbol:  $W_m/\Delta$

Definition:  $W_m = \Delta_{1s} - (\text{sum } W_1 + \dots + W_7)$

Indicator as to the size of the acquisition (design and construction) weight margin that exists for design and construction uncertainties and is dependent on the stage of design. Service life and future growth margin is not included in this weight statement since it is a part of the naval architecture limit.

Significance: Margin is an integration factor and the size is directly proportional to weight and cost.

Expected Range:

Early stage design: 10 - 12.5% light ship

Comparative analysis: no comparative analysis path exists for this indice.

#### SCREEN 2-2: LOAD WEIGHT FRACTIONS

Load weight fractions are variable loads and are added to the light ship weight. Since these items must be stored, they require volume and may result in an addition or reapportionment of existing volume if a change is made. All loads are based on the Navy standard SWBS load groups[22] and are listed as a fraction of the total load weight.

$$W_{ld} = W_{fuel} + W_{ce} + W_{ord} + W_{av} + W_{oth}$$

Liquid (fuel and lubricants)

Symbol:  $W_{fuel}/W_{ld}$

Definition:  $W_{fuel} = F4$

Load weight fraction of the sum of all fuel and lubricants stored onboard. Includes all applicable SWBS Groups F4, F5, and F7 loads listed in reference (22).

Significance: Any difference in liquid loads will result in a volume change in the tankage fraction, which indirectly may affect other volumes and weights.

Comparative analysis examines:

- All Space Type/Location Volume fractions (2-5)
- Ship Mobility Volume fraction (2-4)

#### Crew and Effects

Symbol:  $W_{ce}/W_{ld}$

Definition:  $W_{ce} = F1$

Load weight fraction which includes all crew and effects related loads of applicable SWBS Group F1.

Significance: Change in this group fraction will directly affect internal volume and weight, especially in the human support area.

Comparative analysis examines:

- All Space Type/Location Volume fractions (2-5)
- Human Support Volume Fraction (2-4)

#### Ordnance

Symbol:  $W_{ord}/W_{ld}$

Definition:  $W_{ord} = F2-F23-F26$

Load weight fraction including all non-aviation ordnance related variable loads.

Significance: Differences in this load group fraction directly affect weight and volume fractions in the area of mission support. A steady decrease since 1940 has occurred primarily due to the increased emphasis from guns to missiles.

Comparative analysis examines:

- All Space Type/Location Volume fractions (2-5)
- Mission Support Volume fraction (2-4)

#### Aviation

Symbol:  $W_{av}/W_{ld}$

Definition:  $W_{av} = F23+F26$

Load weight fraction including all aviation variable loads.

Significance: A change in this group will involve weight and volume changes directly in the mission support and possibly in the large space allocation.

Comparative analysis examines:

- All Space Type/Location Volume fractions (2-5)
- Mission Support Volume fraction (2-4)

#### Others

Symbol:  $W_{oth}/W_{ld}$

Definition:  $W_{oth} = F3+F5+F6$

Includes all additional load weights not directly applicable to loadings listed above. These include stores, provisions, non-fuel related liquids, gases and any cargo carried onboard.

Significance: Direct affect on weight and volume. Since stores are additionally included in this category, the endurance period may be affected.

Comparative analysis examines:

- All Space Type/Location Volume fractions (2-5)
- All SSCS Volume fractions (2-4)

#### Total Load Weight to Full Load Displacement Ratio

Symbol:  $W_{ld}/\Delta_{fl}$

Definition: Sum of all variable loads listed above as a fraction of the total ships full load displacement.

Significance: A fraction too large may impact stability in a light-load condition. Large differences between baseline and variant may result in significant volume differences.

Expected Range[24]: frigate 24 - 27%

destroyer 24 - 31% except DDG-51 @ 20.3%

cruiser 25 - 32%

Comparative analysis: no further expansion information exists at this level beyond this screen or in level 3

### Light Ship Displacement to Full Load Displacement Ratio

Symbol:  $\Delta_{1s}/\Delta_{f1}$

Definition: Light Ship to Full Load Displacement ratio, which is the complement to the Load to Full Load ratio above.

Significance: Significant differences in baseline to variant designs indicate differences in load weights.

Expected Range[24]: frigate 72 - 76 %

destroyer 69 - 76 % except DDG-51 @ 79.7%

cruiser 68 - 75 %

Comparative analysis: no further expansion information exists at this level beyond this screen, or in level 3.

### SCREEN 2-3: FUNCTIONAL WEIGHT FRACTIONS

All functional weight fractions are combinations of SWBS and load weights with the margin proportionally distributed by the fraction of screen 2-1. The symbols used are:

$w_{mx}$  = portion of margin allocation of SWBS group 'x'

$w_{mx} = (\%w_x / \text{sum of } \%w_1 \text{ thru } \%w_7) * w_m$

$\%w_x$  = percentage of SWBS group 'x' from screen 2-1

### Light Ship Combat System Weight fraction

Symbol:  $w_{cs1}/\Delta_{1s}$

where  $w_{cs1} = w_4 + w_7 + w_{m4} + w_{m7}$

Definition: Ratio of the sum of the SWBS command and control and armament weights to light ship displacement.

Significance: The larger the ratio, the more the design is driven by the combat system.

Expected Range[24]: frigate 7 - 12 %  
destroyer 9 - 13 %  
cruiser 12 - 15 %

Comparative analysis examines:

- Command and Surveillance Weight fraction (2-1)
- Armament Weight fraction (2-1)

#### Light Ship Machinery Weight fraction

Symbol:  $w_{ma1}/\Delta_{1s}$

where  $w_{ma1} = w_2 + w_3 + w_5 + w_{m2} + w_{m3} + w_{m5}$

Definition: Ratio of the sum of the SWBS main propulsion, electrical and auxiliary weights to the light ship displacement.

Significance: The larger the ratio, the more the design is driven by mobility related items.

Expected Range[24]: gas turbine plant 29 - 35 %  
steam plant 33 - 43 %

Comparative analysis examines:

- Main Propulsion Weight fraction (2-1)
- Electrical Weight fraction (2-1)
- Auxiliary Weight fraction (2-1)

### Light Ship Containment Weight fraction

Symbol:  $W_{c1}/\Delta_{1s}$

where  $W_{c1} = W_1 + W_6 + W_{m1} + W_{m6}$

Definition: Ratio of the sum of the SWBS structural and outfit and furnishings weights to light ship displacement.

Significance: The larger the ratio, the more the design is driven by structural or human support related items.

Expected Range[24]: frigate 55 - 58 %  
destroyer 43 - 61 %  
cruiser 52 - 57 %

Comparative analysis examines:

- Structural Weight fraction (2-1)
- Outfit and Furnishing Weight fraction (2-1)

### Full Load Combat System Weight fraction

Symbol:  $W_{csf}/\Delta_{f1}$

where  $W_{csf} = W_4 + W_7 + W_{ord} + W_{av} + W_{m4} + W_{m7}$

Definition: Ratio of the sum of the SWBS command and control, SWBS armament, load ordnance and load aviation weights to full load ship displacement.

Significance: The larger the ratio, the more the design is driven by the combat system.

Expected Range[24]: frigate 9 - 10 %  
destroyer 9 - 13 %  
cruiser 11 - 12 %

Comparative analysis examines:

- Command and Surveillance Weight fraction (2-1)
- Armament Weight fraction (2-1)
- Ordnance Weight fraction (2-2)
- Aviation Weight fraction (2-2)

#### Full Load Machinery Weight fraction

Symbol:  $w_{maf}/\Delta_{f1}$

$$\text{where } w_{maf} = w_2 + w_3 + w_5 + w_{fuel} + w_{m2} + w_{m3} + w_{m5}$$

Definition: Ratio of the sum of the SWBS main propulsion, electrical and auxiliary weights plus the fuel and lubricant liquid weight to the full load displacement.

Significance: The larger the ratio, the more the design is driven by mobility related items.

Expected Range[24]: gas turbine plant 39 - 44 %  
steam plant 46 - 51 % [24]

Comparative analysis examines:

- Main Propulsion Weight fraction (2-1)
- Electrical Weight fraction (2-1)
- Auxiliary Weight fraction (2-1)
- Liquid Weight fraction (2-2)

#### Full Load Containment Weight fraction

Symbol:  $w_{cf}/\Delta_{f1}$

$$\text{where } w_{cf} = w_1 + w_6 + w_{ce} + w_{oth} + w_{m1} + w_{m6}$$

Definition: Ratio of the sum of the SWBS structural and outfit and furnishings weights plus the load crew and effects and other weights to full load displacement.

Significance: The larger the ratio, the more the design is driven by structural or human support related items.

Expected Range[24]: frigate 45 - 49 %  
destroyer 35 - 49 %  
cruiser 38 - 46 %

Comparative analysis examines:

- Structural Weight fraction (2-1)
- Outfit and Furnishing Weight fraction (2-1)
- Crew and Effects Weight fraction (2-2)
- Other Weight fraction (2-2)

#### SCREEN 2-4: SSCS VOLUME FRACTIONS

The U.S. Navy Ships Space Classification System [23] separates all volumes into one of the five major classifications used in this screen. These are displayed as a fraction of the total ship enclosed volume. The major classifications are each further divided into sub-categories, which are examined by the comparative analysis structure to provide the designer information regarding the specific area of volume change impact.

Mission Support fraction

Symbol:  $V_1 / \nabla$

**Definition:** Military mission support volume fraction including all SSCS Group 1 volumes listed in reference (23). For combatant destroyer type ships, these include all command and surveillance, communications, weapons and aviation related volumes.

**Significance:** Driven by mission and combat systems. The larger the fraction, the more significant the mission impact is on the ship. A change in the aviation area may result in "large space volume" changes. The recent increase in payload volume has been reflected due to the change from guns to missiles and the increased emphasis on command, control and communications.

**Expected Range[24]:** frigates 20 - 22 %  
destroyers 13 - 19 %  
cruisers 21 - 24 %

**Comparative analysis examines:**

- Combat Systems Volume Allocation (2-6)
- Large Space Volume fraction (2-5)
- All Combat System Volume Fractions (3-9)
- All Combat System Densities (3-10)

#### **Human Support**

**Symbol:**  $V_2 / \nabla$

**Definition:** Human support volume fraction including all SSCS Group 2 volumes as listed in reference (23). These



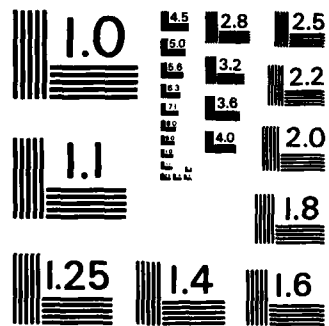

MICROCOPY RESOLUTION TEST CHART  
NATIONAL BUREAU OF STANDARDS-1963-A

include living, messing, medical, and general service type volumes.

**Significance:** Driven by human support and manning requirements.

A "plush" habitability ship would have a greater fraction than a ship designed for "austere" habitability, if manning were constant. Although there have been extensive increases in habitability requirements requiring additional volume per crewmember, the decrease in the overall manning has effectively caused a downward trend in this volume area.

**Expected Range[24]:** frigates 20 - 21 %

destroyers 16 - 27 %

cruisers 16 - 24 %

**Comparative analysis examines:**

- All Human Support Volume Breakdown (3-11)
- Human Support Density (3-12)
- Human Support Specific Volume (3-12)
- Personnel Living Space Specific Volume (3-12)

#### **Ship Support**

**Symbol:**  $V_3 / \nabla$

**Definition:** Ship support volume fraction including all SSCS Group 3 volumes as listed in reference (22). These volumes include ship control, damage control, administration, deck

systems, boats, maintenance, storerooms, access areas and tankage.

Significance: Ship support relates a large portion of ship required volumes that relate to auxiliaries and storage and may be impacted significantly by changes in range and endurance period requirements. Recent trends have shown an increase due to increased emphasis on storage to improve sustainability, more allocation to accesses for habitability and increased requirements of auxiliaries.

Expected Range[24]: frigates 27 - 34 %

destroyers 18 - 29 % except DD963 @ 34%

cruisers 28 - 30 %

Comparative analysis examines:

- Tankage Volume fraction (2-5)
- Machinery Related Volume fraction (2-6)
- Auxiliary Volume Breakdown (3-7)
- Auxiliary Density (3-8)
- Auxiliary Specific Weight (3-8)
- Auxiliary Volume fraction (3-8)

#### Ship Mobility

Symbol:  $V_4 / \nabla$

Definition: Ship mobility volume fraction including all SSCS Group 4 volumes as listed in reference (23). These include propulsion, propulsor and transmission, intake and

exhaust, auxiliary machinery and electrical power generation and distribution related volumes.

Significance: Size of fraction indicates the extent that the design is driven by mobility. Some of this volume may be directly related to "large-space" volume in the form of major machinery spaces. Recent designs show a downward trend in this fraction due to the decreased SHP/ton requirements of the gas turbine versus steam. The Comparative analysis path examines the primary area of volume impact.

Expected Range[24]: gas turbine plant 26 - 32 %  
steam plant 30 - 42 %

Comparative analysis examines:

- Large Space Volume fraction (2-5)
- Machinery Related Volume fraction (2-6)
- Main Propulsion Volume Breakdown (3-3)
- Electric Plant Volume Breakdown (3-5)
- Main Propulsion Density (3-4)
- Main Propulsion Volume fraction (3-4)
- Electrical Density (3-6)
- Electrical Volume fraction (3-6)
- Auxiliary Volume Breakdown (3-7)
- Auxiliary Density (3-8)

### Unassigned

Symbol:  $V_5 / \nabla$

Definition: Includes all volume and volume margin not assigned to any of the specific functions listed above.

Significance: May include volume margin which directly impacts displacement.

Expected Range: Zero or very small percentage

Comparative analysis: No Comparative analysis exists for this item.

### SCREEN 2-5: SPACE TYPE/LOCATION VOLUME FRACTION

This screen is used to display where the main allocations of volume are located, as a fraction of the total enclosed volume. It provides a quick look at how much of the actual ship volume is in the superstructure and hull, as well as how much of it is considered arrangeable. It provides an excellent comparison for two radically different ship hulls.

Since these indices are used primarily to provide a large scale comparison, the analysis branch structure will send the designer back to the appropriate SSCS volume fraction where more detailed analysis is available and will examine affected level 3 specific weights.

### Hull Volume

Symbol:  $V_{\text{hull}} / \nabla$

**Definition:** Total enclosed volume fraction of the hull area only.

**Significance:** Changes in hull volume will affect hull size and characteristics, thereby indirectly affecting powering and resistance. The recent trend has been to locate all vital equipment in the hull, thus increasing the hull volume fraction.

**Comparative analysis examines:**

- All SSCS Volume fractions (2-4)
- Basic Hull Structure Density (3-2)

#### **Deckhouse Volume**

**Symbol:**  $V_{dh} / \nabla$

**Definition:** Total enclosed volume fraction of the deckhouse area.

**Significance:** An increased volume in the deckhouse will increase radar signature as well as providing more weight high in the design, possibly affecting stability.

**Comparative analysis examines:**

- All SSCS Volume fractions (2-4)
- Deckhouse Structure Density (3-2)

#### **Tankage/Voids Volume**

**Symbol:**  $V_{tk} / \nabla$

**Definition:**  $V_{tk} = V_{3.9}$  : Total volume fraction of all tankage as defined by SSCS Group 3.9 [23].

**Significance:** The largest percentage of tankage is the ships fuel and any change in propulsion size or endurance required will affect the tankage volume and either make the ship larger or take away volume from other areas.

**Expected Range[24]:** 6.5 - 12.5 %

**Comparative analysis examines:**

- Ship Support Volume fraction (2-4)
- Machinery Related Volume fraction (2-6)

#### **Large Space Volume**

**Symbol:**  $V_{10} / \nabla$

**Definition:**  $V_{10} = V_{1.2} + V_{1.34} + V_{4.1}$

Total volume fraction of all "large object" volume items, which include the SSCS groups [23] weapons and ammunition ( $V_{1.2}$ ), aircraft stowage ( $V_{1.34}$ ) and propulsion systems ( $V_{4.1}$ ).

**Significance:** Changes in ships weapons, number of aircraft or propulsion plant size will significantly impact this indice, which may have direct impact on arrangeable volume or ship size.

**Comparative analysis examines:**

- Ship Mobility Volume fraction (2-4)
- Combat Systems Volume fraction (2-6)
- Machinery Related Volume fraction (2-6)

### Arrangeable Volume

Symbol:  $V_a / \nabla$

Definition:  $V_a = V - V_{tk} - V_{lo}$

Total volume fraction of arrangeable volume. Tankage and large object space is not considered as arrangeable space. This volume is used for general arrangements.

Significance: The greater the fraction, the more spacious the ship will be, thus allowing more area for maintenance spaces and habitability. If this area is excess, then it may be possible to decrease the size of the ship.

Comparative analysis examines:

- All Volume Allocation fractions (2-6)

### SCREEN 2-6: FUNCTIONAL VOLUME ALLOCATION FRACTIONS

The indices on this screen are used to separate and analyze the volumes with respect to the major functional users of volume on a naval combatant ship. These indices are then further analyzed during the Level 3 Functional Investigation. The comparative analysis methodology will examine the functional area to provide further impact analysis study. Unassigned volume will not be distributed as margin was in weight. Instead, it will be treated as a separate category.

### Combat Systems Volume

Symbol:  $V_{cs} / \nabla$

Definition:  $V_{cs} = V_1$

Volume fraction allocated to combat systems, which in this case, is the same as the mission support volume.

Significance: Driven by the ships mission and type of combat systems installed. The larger the fraction, the more significant the mission impact is on the ship. The specific area of emphasis may be determined by examining the functional allocation of level 3. The recent increase in combat systems volume has been reflected due to the change from guns to missiles and the increased emphasis on command, control and communications.

Comparative analysis examines:

- Large Space Volume fraction (2-5)
- All Combat System Volume Fractions (3-9)
- All Combat System Densities (3-10)

#### Machinery Related Volume

Symbol:  $V_{ma} / \nabla$

Definition:  $V_{ma} = V_4 + V_{3.5} + V_{3.9}$

Volume fraction allocated to the machinery plant, including propulsion, transmission, electric plant, auxiliaries, auxiliary deck machinery and tankage.

Significance: Driven by the type of machinery plant and the speed and endurance required. The size of the fraction indicates how much the machinery plant drives the design.

The specific areas of impact and actual drivers are detailed in level 3 functional allocation.

Comparative analysis examines:

- Large Space Volume fraction (2-5)
- Main Propulsion Volume Breakdown (3-3)
- Electric Plant Volume Breakdown (3-5)
- Auxiliary Volume Breakdown (3-7)
- Main Propulsion Density (3-4)
- Main Propulsion Volume fraction (3-4)
- Electrical Density (3-6)
- Electrical Volume fraction (3-6)
- Auxiliary Density (3-8)
- Auxiliary Specific Weight (3-8)
- Auxiliary Volume fraction (3-8)

#### Containment Volume

Symbol:  $V_c / \nabla$

Definition:  $V_c = V_2 + V_3 - V_{3.5} - V_{3.9}$

Volume fraction allocated to containment, which includes human support and ship support without deck machinery and tankage.

Significance: Driven primarily by human support and manning requirements to support the ships mission. Although the trend has been to increase habitability standards, the

manning has decreased, thus negating the anticipated increase in containment volume.

Comparative analysis examines:

- All Human Support Volume Breakdown (3-11)
- Human Support Density (3-12)
- Human Support Specific Volume (3-12)
- Personnel Living Space Specific Volume (3-12)

#### Unassigned

Symbol:  $V_5 / \nabla$

Definition: Includes all volume and volume margin not assigned to any of the specific functions listed above.

Significance: May include volume margin which directly impacts displacement.

Comparative analysis: No Comparative analysis exists for this item.

#### SCREEN 2-7: ELECTRICAL ENERGY ALLOCATION FRACTIONS

The energy allocation fractions are categorized by standard Navy SWBS groups [22]. Each fraction is user selectable to be a function of either maximum functional electric load or installed electric load capacity, which is defined as 90% of the total electric power available of all generators minus one. Navy standards require one generator available as an emergency standby at all times. Additionally, Navy standards look at the energy usage at a 100°F day and a 90°F day and at conditions of battle,

cruise, and anchor. If the data bank in use contains all the standard Navy conditions, the user will have the option of selecting either temperature and battle or cruise conditions. If no specific selection is made, the 10°F day at battle condition will be used for comparison purposes.

Since no level of analysis exists beyond the first level electrical SWBS groupings, no further comparative analysis will be available.

Standard symbols used are:

$E_t$  = maximum functional electric load

$E_i$  = installed electric load capacity

$E$  = choice of max functional or installed capacity

#### Propulsion Plant

Symbol:  $E_2 / E$

Definition: Fraction of electrical power used for the propulsion plant which includes all SWBS group 2 electric power usage. The propulsion plant electric power requirements are not expected to change for the life of the ship, therefore when calculating electric service life margin, this SWBS group will be excluded.

Significance: Dependent upon size and type of power plant in use on the design.

#### Electric Plant

Symbol:  $E_3 / E$

**Definition:** Fraction of electrical power used for the electric power generation and distribution which includes all SWBS group 3 electrical power usage.

**Significance:** Dependent upon size and type of electric plant in use on the design.

#### **Command and Surveillance**

**Symbol:**  $E_4 / E$

**Definition:** Fraction of electrical power used for command and surveillance systems which include all SWBS group 4 electrical power usage.

**Significance:** Dependent upon size and type of command and surveillance systems used in the design.

#### **Auxiliary**

**Symbol:**  $E_5 / E$

**Definition:** Fraction of electrical power used for auxiliary systems which include all SWBS group 5 electrical power usage.

**Significance:** Dependent upon size and type of auxiliary systems used in the design. The largest user in this group is generally SWBS group 514, the HVAC system.

#### **Outfit and Furnishings**

**Symbol:**  $E_6 / E$

as well as the purchase of raw materials and contractor furnished equipment.

Significance: Direct relationship to the weight of the SWBS group and is additionally a function of the equipment and material used in the group. Actual calculations for preliminary designs are based on information obtained from earlier similar designs.

#### D & C Margin

Symbol:  $C_m/C_{bc}$

Definition: Design and Construction cost margin, a fraction of the SWBS group cost, generally a function of the type and size of the ship, and may even be a function of the shipyard performing the construction.

Significance: Generally applied equally over all SWBS cost groups above.

#### Design and Engineering (Group 8)

Symbol:  $C_{de}/C_{bc}$

Definition: A part of the basic construction cost of the shipbuilder, it includes all costs relating to waterfront engineering and testing.

Significance: Generally applied as a percentage of light ship construction and materials required.

The cost comparative analysis should generally be used only after all other comparisons have been completed in the analysis and the designer is checking cost variance for a known change or impact. It is for this reason that there will be no automated comparative analysis path for the cost related screens.

**SCREEN 2-11: BASIC CONSTRUCTION COST ALLOCATION**

The user has the choice of selecting either "lead" or "follow" ship cost. Symbols used are:

$$C_{bc} = C_1 + \dots + C_7 + C_m + C_{de} + C_{con} + C_{pr}$$

$$C_{BC} = C_1 + \dots + C_7 + C_m + C_{de} + C_{con} + C_{pr} + C_{HM\&E}$$

**SWBS Groups 1 thru 7 Related Costs**

Symbol: Each parameter is given separately. May be either "lead" or "follow" ship costs as selected by user.

Hull Structure	$C_1/C_{bc}$
Propulsion Plant	$C_2/C_{bc}$
Electric Plant	$C_3/C_{bc}$
Command and Surveillance	$C_4/C_{bc}$
Auxiliary Systems	$C_5/C_{bc}$
Outfit and Furnishing	$C_6/C_{bc}$
Armament	$C_7/C_{bc}$

Definition: The cost of fabricating and constructing the ship is partially cataloged by SWBS groups. As a portion of the basic construction cost, this includes direct labor and overhead involved with the installation of all equipment

- All Human Support Drivers (3-12)
- Human Support Density (3-12)
- Human Support Specific Volume (3-12)

#### Aviation Manning Ratio

Symbol:  $M_{av} / M_a$

Comparative analysis examines:

- All Human Support Breakdown (3-11)
- All Human Support Drivers (3-12)
- Human Support Density (3-12)
- Human Support Specific Volume (3-12)

#### SCREENS RELATING TO COST

All costs are classified according to the standard Navy "P8" Cost Breakdown structure.

The accuracy of the cost comparisons during comparative analysis will be directly dependent on the source of data. The designer should be familiar with the accuracy of the source he is working with and should be extremely careful in comparisons that are not from the same source. As an example, to take the DD-963 from a very accurate database that has actual real costs and compare it to a variant from the ASSET program may result in a very poor and probably inaccurate comparison. This section of the module should then only be used as a rough comparison and then only when the ships being compared are from the same source, such as a baseline and a variant both developed on the ASSET program.

**Comparative analysis examines:**

- All Human Support Breakdown (3-11)
- All Human Support Drivers (3-12)
- Human Support Density (3-12)
- Human Support Specific Volume (3-12)

**Engineering Manning Ratio**

Symbol:  $M_{eng} / M_a$

**Comparative analysis examines:**

- All Human Support Breakdown (3-11)
- All Human Support Drivers (3-12)
- Human Support Density (3-12)
- Human Support Specific Volume (3-12)

**Nav/Admin Manning Ratio**

Symbol:  $M_{na} / M_a$

**Comparative analysis examines:**

- All Human Support Breakdown (3-11)
- All Human Support Drivers (3-12)
- Human Support Density (3-12)
- Human Support Specific Volume (3-12)

**Supply Manning Ratio**

Symbol:  $M_{sup} / M_a$

**Comparative analysis examines:**

- All Human Support Breakdown (3-11)

proportionally distributed based on the size of the departmental manning.

$M_a$  = total manning accommodations (OFF+CPO+ENL)

$M_{xxx}$  = manning for department 'xxx'

Significance: Shipboard manning is dependent on the types and sizes of systems installed on the ship and is impacted by operational considerations, maintenance and support requirements, and scheduled workweek. A change in a ship system may result in a corresponding manning change. If the manning fraction goes up, the resulting living area or volume may not be able to increase accordingly, thus resulting in a degradation of habitability standards. This could be a substantial impact to a new technology assessment.

#### Combat Systems Manning Ratio

Symbol:  $M_{CS} / M_a$

Comparative analysis examines:

- All Human Support Breakdown (3-11)
- All Human Support Drivers (3-12)
- Human Support Density (3-12)
- Human Support Specific Volume (3-12)

#### Operations Manning Ratio

Symbol:  $M_{ops} / M_a$

### Enlisted Ratio

Symbol:  $M_{enl} / M_a$

Comparative analysis examines:

- All Human Support Drivers (3-12)
- Enlisted Living Area per man (3-12)
- Enlisted Ship Size Ratio (3-12)

### Manning Margin

Symbol:  $M_m / M_a$

Definition:  $M_m = M_a - (M_{off} + M_{cpo} + M_{enl})$

Accommodation growth margin to allow for uncertainties in manning estimates and future expansion.

Significance: Each accommodation requires space and weight. An insufficient margin may result in the inability to berth all necessary personnel, whereas a large margin may result in use of space and weight that could be better used elsewhere.

Comparative analysis examines:

- All Functional Manning Allocation (2-10)

### SCREEN 2-10: FUNCTIONAL MANNING ALLOCATION FRACTIONS

A general definition and significance will suffice for all indices used, and then the symbols and expected ranges will be addressed independently with each indice.

Definition: Ratios of number of personnel by ship department to the total number of accommodations. The manning margin is

Significance: Shipboard manning is dependent on the types and sizes of systems installed on the ship and is impacted by operational considerations, maintenance and support requirements, and scheduled workweek. A change in a ship system may result in a corresponding manning change. If the manning fraction goes up, the resulting living area or volume may not be able to increase accordingly, thus resulting in a degradation of habitability standards. This could be a substantial impact to a new technology assessment.

#### Officer Ratio

Symbol:  $M_{\text{off}} / M_a$

Comparative analysis examines:

- All Human Support Drivers (3-12)
- Officer Living Area per man (3-12)
- Officer Ship Size Ratio (3-12)

#### CPO Ratio

Symbol:  $M_{\text{cpo}} / M_a$

Comparative analysis examines:

- All Human Support Drivers (3-12)
- CPO Living Area per man (3-12)
- CPO Ship Size Ratio (3-12)

Comparative analysis examines:

- Main Propulsion Electric Allocation (2-7)
- Electric Plant Electric Allocation (2-7)
- Auxiliaries Electric Allocation (2-7)

#### Containment Electrical

Symbol:  $E_c / E$

Definition:  $E_c = E_{\delta} [+E_{m\delta}]$

Percentage of total installed electric generation capability allocated to containment. Since SWBS group 1 (structures) uses no electric power, only the outfit and furnishings group is included.

Significance: Driven by human support requirements in the outfit and furnishings group.

Comparative analysis examines:

- Outfit and Furnishings Electric Allocation (2-7)

#### SCREEN 2-9: MANNING ALLOCATION FRACTION

A general definition and significance will suffice for all indices used, and then the symbols and expected ranges will be addressed independently with each indice.

Definition: Ratios of number of personnel by rank to the total number of accommodations.

$M_a$  = total manning accommodations (OFF+CPO+ENL)

$M_{xxx}$  = manning for 'xxx' personnel

the fraction of use for the same temperature and condition as displayed in screen 2-7. No service life margin is allocated to group 2, propulsion.

$E_{mx}$  = portion of margin allocation of SWBS group 'x'

$E_{mx} = (\%E_x / \text{sum of } \%E_3 \text{ thru } \%E_7) * E_m$

$\%E_x$  = percentage of SWBS group 'x' from screen 2-7

NOTE: Margin fractions added only when  $E_i$  is selected

#### Combat System Electrical

Symbol:  $E_{cs}/E$

Definition:  $E_{cs} = E_4 + E_7 [+E_{m4} + E_{m7}]$

Percentage of total installed electric load allocated to combat systems.

Significance: Driven by size and complexity of the combat system installed.

Comparitive analysis examines:

- Command and Surveillance Electric Allocation (2-7)
- Armament Electric Allocation (2-7)

#### Machinery Electrical

Symbol:  $E_{ma}/E$

Definition:  $E_{ma} = E_2 + E_3 + E_5 [+E_{m3} + E_{m5}]$

Percentage of total installed electric load allocated to machinery.

Significance: Driven by size, type and complexity of the ships machinery, including propulsion, electrical and auxiliary.

fuel efficiency of the engines can be compared by looking at actual specific fuel consumption (SFC).

Comparitive analysis examines:

- All Installed HP Allocation (2-8)
- All Main Propulsion Drivers (3-4)
- All Electrical Drivers (3-6)

#### Electrical Fuel Allocation

Symbol:  $FF_{gen}/FF_t$

Definition: Average fuel flow fraction allocated to the electric plant based on 24 hr average load.

Significance: Provides indication of electric plant fuel efficiency as compared to the propulsion plant. The actual fuel efficiency of the electric plant can be compared by observing the actual electric specific fuel consumption (SFCA).

Comparitive analysis examines:

- All Installed HP Allocation (2-8)
- All Main Propulsion Drivers (3-4)
- All Electrical Drivers (3-6)

#### ELECTRICAL:

The selections of temperature and conditions available is the same as specified in screen 2-7.

When the installed electric capacity ( $E_i$ ) is selected, the electric margin is proportionally distributed to groups  $E_3$  to  $E_7$  as

efficient or larger electric plant or to a more efficient or smaller propulsion plant.

Comparitive analysis examines:

- All Fuel Usage Allocation (2-8)
- All Main Propulsion Drivers (3-4)
- All Electrical Drivers (3-6)

#### FUEL USAGE:

Propulsion fuel usage is based on endurance speed. Electrical fuel usage is based on average 24 hour load[18].

NOTE:  $SFCA_e$  = Generator SFC at 24 hr average load

$SFC_e$  = Propulsion SFC at endurance speed

$HP_{gene}$  = Generator Horsepower at 24 hr avg load

$HP_{shpe}$  = Propulsion horsepower at endurance spd

$FF_{gen}$  = Generator Fuel flow (lbm/hr)  
( $FF_{gen} = SFCA_e * HP_{gene}$ )

$FF_{mp}$  = Main Propulsion fuel flow (lbm/hr)  
( $FF_{mp} = SFC_e * HP_{shpe}$ )

$FF_t$  = Total fuel flow (lbm/hr)  
( $FF_t = FF_{gen} + FF_{mp}$ )

#### Propulsion Fuel Allocation

Symbol:  $FF_{mp}/FF_t$

Definition: Average fuel flow fraction allocated to the propulsion plant at endurance speed.

Significance: Provides indication of propulsion plant fuel efficiency as compared to the electric plant. The actual

### Propulsion Horsepower Allocation

Symbol:  $HP_{shpi}/HP_t$

Definition: Fraction of total horsepower installed that is allocated to main propulsion.

Significance: Dependent on the size and type of propulsion plant in use as compared to the electric plant. A larger fraction may indicate either a larger or less efficient propulsion plant or a more efficient electric plant. These two fractions may be misinterpreted if they are looked at individually.

Comparative analysis examines:

- All Fuel Usage Allocation (2-8)
- All Main Propulsion Drivers (3-4)
- All Electrical Drivers (3-6)

### Electrical Horsepower Allocation

Symbol:  $HP_{geni}/HP_t$

Definition: Fraction of total horsepower installed allocated to electric power generation.

Significance: Dependent on the size and type of electric plant as compared to the main propulsion plant. Any comparisons must include the main propulsion horsepower allocation above to prevent misinterpretation of the results. An increase in this fraction may be due to either a less

remaining generators. The margin is then the difference between the available power to use and the maximum functional load and is dependent on the stage of design. Navy expected values are listed below.

Significance: The addition or change of subsystems may result in an increase in power requirements that may cause an insufficient margin to maintain the Navy requirements, or the margin may be excess and allow a downgrade of generator number or rating.

Expected Range:

Ship Service Margins[28]:

End of preliminary design	44%
End of detail design	34%
Ship Delivery	20%

#### SCREEN 2-8: FUNCTIONAL ENERGY ALLOCATION FRACTIONS

The energy allocation is broken into three subcategories for horsepower, fuel and electrical usage. The first two categories provide for a propulsion versus electric plant comparison and the last provides the breakdown of electric power usage into the three primary users.

INSTALLED HP:

NOTE:  $HP_{shpi}$  = Total shaft horsepower installed

$HP_{geni}$  = Total generator horsepower installed

$HP_t = HP_{shpi} + HP_{geni}$

Definition: Fraction of electrical power used for outfit and furnishings which include all SWBS group 6 electrical power usage.

Significance: Dependent upon manning and type of habitability installed in the design.

#### Armament

Symbol:  $E_7 / E$

Definition: Fraction of electrical power used for armament systems which include all SWBS group 7 electrical power usage.

Significance: Dependent upon size and type of armament systems used in the design.

#### Margin

Symbol:  $E_m / E$

Definition:  $E_m = .9 * (E_i - \text{KW rating of one generator}) - E_t$

Fraction of electrical load margin which includes both acquisition margin and service life margin. Acquisition margin is added during design to account for uncertainties of KW requirements during design. A completed design should have an acquisition margin of zero. In compliance with reference (28), the margin must be sufficient to allow one generator to stay off-line and be available in the event of a casualty. The ship peak power should then not exceed 90% of the available installed power of the

### Construction Services/Assembly (Group 9)

Symbol:  $C_{con}/C_{bc}$

Definition: A part of the basic construction cost relating to the assembly of non-SWBS related material or equipment.

Significance: Generally applied as a percentage of light ship construction and materials required.

### Profit

Symbol:  $C_{pr}/C_{bc}$

Definition: Part of the basic construction cost pertaining to the shipbuilder's profit. Calculated as a percentage of cost of all SWBS groups 1 thru 7 plus groups 8 and 9.

Significance: Dependent on the competition environment, it is negotiated with the builder and is generally in the range of 5 - 15% of basic construction costs.

### HM&E GFE

Symbol:  $C_{HM\&E}/C_{BC}$

Definition: Cost fraction of government furnished HM&E equipment to the basic construction cost plus HM&E GFE.

Significance: Dependent on the amount of HM&E GFE being provided to the builder. In recent years, the builder has purchased more of the HM&E type equipment, thus driving this fraction down considerably.

## SCREEN 2-12: FUNCTIONAL COST ALLOCATION FRACTION

Choice of selection of "lead ship" or "follow ship"

Total cost defined as:

$$(C_t = C_1 + \dots + C_7 + C_m + C_{de} + C_{con} + C_{pr} + C_{oth} + C_{csgfe})$$

Symbols defined in screen 1-1 and 2-11.

All non-SWBS related basic construction costs are distributed proportionally in the percentages allocated in screen 2-11.

All "Other Costs" are distributed proportionally as allocated in Screen 2-11 with the exception of P.M. Growth which is added directly to Combat Systems Costs.

$C_{dx}$  = distributed costs for SWBS group 'x'

$$= (C_x / \text{sum of } \%C_1 \text{ thru } \%C_7) * (C_m + C_{de} + C_{con} + C_{pr} + C_{oth} - \text{pmg})$$

where  $C_x$  = % cost of SWBS group 'x' (screen 2-11)

### Combat Systems Costs

Symbol:  $C_{cs}/C_t$

Definition:  $C_{cs} = C_4 + C_7 + C_{csgfe} + \text{pmg} + d_4 + d_7$

Those costs directly relating to the combat systems of the ship including the combat system related construction cost as well as all combat system GFE and project manager growth costs.

Significance: Indication of how much the combat system drives the cost of the design.

### Machinery Costs

Symbol:  $C_{ma}/C_t$

Definition:  $C_{ma} = C_{2+3+5+d2+d3+d5}$

Sum of all costs relating to machinery including main propulsion, electrical and auxiliary.

Significance: Indication of how much the machinery drives the cost of the design.

#### Containment Costs

Symbol:  $C_c/C_t$

Definition:  $C_c = C_{1+6+d1+d6}$

Sum of costs directly related to the containment of the ship including structures and outfit and furnishings.

Significance: Indication of how much the containment drives the cost of the design.

#### SCREEN 2-13: COST FRACTIONS

Symbols used:

$C_{1s}$  = Lead Ship Total Cost

$C_{fs}$  = Follow Ship Total Cost

#### Combat System GFE/Lead Ship Cost

Symbol:  $C_{csgfe}/C_{1s}$

Definition: The fraction of "lead" ship cost that is directly related to combat system GFE (Government Furnished Equipment).

Significance: Driven by the size and complexity of the combat system installed in the design. The "rule of thumb" fraction for a combatant is approximately 42 - 45%.

#### Combat System GFE/Follow Ship Cost

Symbol:  $C_{csgfe}/C_{fs}$

Definition: The fraction of "follow" ship cost that is directly related to combat system GFE (Government Furnished Equipment).

Significance: Driven by the size and complexity of the combat system installed in the design. The "rule of thumb" fraction for a combatant is about the same as the lead ship cost which is approximately 42 - 45%.

#### Basic Construction/Lead Ship Cost

Symbol:  $C_{bc}/C_{ls}$

Definition: The fraction of "lead" ship cost that is paid for basic construction, where basic construction cost is as defined in screen 2-11.

Significance: Driven by the size and complexity of the ship construction. General "rule of thumb" percentage is 28-30%.

#### Basic Construction/Follow Ship Cost

Symbol:  $C_{bc}/C_{fs}$

**Definition:** The fraction of "follow" ship cost that is paid for basic construction, where basic construction cost is as defined in screen 2-11.

**Significance:** Driven by the size and complexity of the ship construction. General "rule of thumb" percentage is higher than for the lead ship at 37-40%.

#### **Total Follow Ship Cost/Weight ratio**

**Symbol:**  $C_{fs}/\Delta_f$  (\$/ton)

**Definition:** Specific cost to weight ratio of the "follow" ship.

**Significance:** An efficient design may have a higher cost yet still maintain a more efficient cost to weight ratio. This may be a deciding factor in two closely related designs. The follow ship tends to be a better indicator since these costs will prevail throughout the life of the construction. The lead ship cost may be deceiving if it uses new expensive technology which may get cheaper in subsequent deliveries.

#### **Total Follow Ship Cost/Volume ratio**

**Symbol:**  $C_{fs}/\nabla$  (\$/ft<sup>3</sup>)

**Definition:** Specific "follow" ship cost to volume ratio.

**Significance:** Designer wants a lower ratio, which indicates that more volume is obtained per dollar spent.

### LEVEL 3: FUNCTIONAL INVESTIGATIONS

This third level of analysis further investigates the impact of a Level 1 change. In the comparative analysis path, the Level 3 analysis will concentrate on finding the cause. Therefore, all indice comparative analysis branches will examine the appropriate Level 1 parameters to discover the reason the change occurred. The primary questions asked by the comparative analysis path are:

- \* What drives the indice or parameter
- \* What caused the indice or parameter to change

Each of the six ships functions have a two screen display, the first serves as a further breakdown of weight and volume and the second screen is divided into the primary drivers for the functional area and related miscellaneous indices. The drivers addressed in the screens are additionally available to be viewed in the trend analysis section as a "triple plot" where the new design can be compared to existing designs for the functional area under investigation.

The last screen in this level is a summary of all acquisition and service life margins.

Where all indices are closely related and self-explanatory, as in the weight and volume breakdowns, only a single definition, significance and comparative analysis path will be provided.

All SWBS weight groups and subgroups are as defined in reference (22) and SSCS volume groups and subgroups as defined in reference (23).

### SCREEN 3-1: CONTAINMENT WEIGHT BREAKDOWN

#### STRUCTURE WEIGHT:

##### Symbols:

Shell and Supports	$W_{11}/W_1$
Hull Structural Bulkheads and Decks	$W_{12+13+14}/W_1$
$W_{12}$ = hull structural bulkheads	
$W_{13}$ = hull decks	
$W_{14}$ = hull platforms and flats	
Deckhouse	$W_{15}/W_1$
Foundations	$W_{18}/W_1$
Other Structural	$W_{16+17+19}/W_1$
$W_{16}$ = special structures	
$W_{17}$ = masts, kingposts, service platforms	
$W_{19}$ = special purpose systems	

Definition: The further distribution of containment weight within the ship as a ratio of total SWBS Group 1 weight.

Significance: A difference in these indices may occur due to a different type of material, frame spacing, a change in ship size, or in structural loading. These changes may be caused by differing survivability requirements.

Comparative analysis: All indices will be examined with the same comparative analysis branch which includes:

- All Size Characteristics (1-1)
- All Ship Performance Survivability (1-3)
- All Structure/Materials Selections (1-4)

## OUTFIT AND FURNISHINGS WEIGHT

### Symbols:

#### Crew Related

$$W_{64+65+66+67}/W_6$$

$W_{64}$  = Living Space

$W_{65}$  = Service Space

$W_{66}$  = Working Space

$W_{67}$  = Stowage Space

#### Non-Crew Related

$$W_{61+62+63+69}/W_6$$

$W_{61}$  = Ship Fittings

$W_{62}$  = Hull Compartmentation

$W_{63}$  = Preservatives/Coverings

$W_{69}$  = Special Purpose Systems

**Definition:** Broken into two subcategories of either crew related or non crew related and compared as a ratio of total SWBS Group 6 weight.

**Significance:** Directly affected by human support requirements and crew size for the crew related items and by hull compartmentation and fittings for the non crew related items.

**Comparative analysis:** All indices will be examined with the same comparative analysis branch which includes:

- All Size Characteristics (1-1)
- All Structure/Materials Selection (1-4)
- All Deck Heights (1-4)
- All Manning (1-4)

## SCREEN 3-2: CONTAINMENT INDICES

### CONTAINMENT DRIVERS:

Primary drivers of containment based on the "triple plot" relationships:

$$W_1/\Delta_{f1} = (W_1/\nabla) * (\nabla/\Delta_{f1})$$

$$W_6/\Delta_{f1} = (W_6/\nabla) * (\nabla/\Delta_{f1})$$

### Structural Weight Fraction

Symbol:  $W_1/\Delta_{f1}$

Definition: The fraction of total full load displacement allocated to ship structures.

Significance: Extremely dependent on volume. It is affected by many variables, including length, volume, displacement, hull form, local loading, ship dimension ratios, penetrations, frame spacing and materials. The recent trend to increased ship volume has resulted in an upward trend in structural weight.

Comparative analysis examines:

- All Ship Size Characteristics (1-1)
- All Shape Characteristics (1-2)
- All Survivability Ship Performance (1-3)
- All Structure/Materials (1-4)

### Outfit and Furnishings Weight Fraction

Symbol:  $W_6/\Delta_{f1}$

Definition: The fraction of total full load displacement allocated to outfit and furnishings SWBS group 6.

Significance: Since much of this weight group relates to human support, it is directly affected by the manning size and the type of habitability installed, which in effect drive volume. Since the trend has been to improve habitability, this fraction has shown an increase in recent years.

Comparative analysis examines:

- All Ship Size Characteristics (1-1)
- All Shape Characteristics (1-2)
- All Manning (1-4)

#### Total Hull Structure Specific Weight

Symbol:  $w_1/\nabla$  (lbs/ft<sup>3</sup>)

Definition: Ratio of ship structural weight to total enclosed volume.

Significance: Provides indicator as to which is the driving factor when both both structural weight and volume are changed, or the effect of loading changes which results in a heavier structure. Driven by changes in ship size, loading, materials used, or survivability requirements. An increase in this parameter will drive an increase in the structural weight fraction.

Comparative analysis examines:

- All Size Characteristics (1-1)

- All Shape Characteristics (1-2)
- All Ship Performance Survivability (1-3)
- All Structure/Materials Selections (1-4)

#### Outfit and Furnishings Specific Weight

Symbol:  $W_o/\nabla$  (lbs/ft<sup>3</sup>)

Definition: Ratio of ship outfit and furnishings weight to total enclosed volume.

Significance: Provides indicator of how much the outfit and furnishings weight drives the volume of the design. Directly impacted by the habitability requirements and the manning accommodations, as well as by some structural hull compartmentation requirements.

Comparative analysis examines:

- All Size Characteristics (1-1)
- All Shape Characteristics (1-2)
- All Structure/Materials Selections (1-4)
- All Manning (1-4)

#### Ship Specific Volume

Symbol:  $\nabla/\Delta_{f1}$  (ft<sup>3</sup>/ton)

Definition: Ratio of total enclosed volume to full load displacement.

Significance: Indication of spaciousness and how the volume drives the design. The larger the specific volume, the more spacious the design is. Recent trends have been

toward an increase in specific volume. As the spaciousness increases, the associated weight fraction also increases.

Comparative analysis examines:

- All Size Characteristics (1-1)
- All Shape Characteristics (1-2)

#### RELATED CONTAINMENT RATIOS:

##### Containment Density

Symbol:  $W_{cf}/V_c$

Definition: Ratio of full load containment weight to containment volume as defined in screens 2-3 and 2-6.

Significance: Provides information regarding the relative effect of containment weight to volume. Indicates spaciousness of containment items. Driven primarily by structure and habitability requirements.

Comparative analysis examines:

- All Ship Size Characteristics (1-1)
- All Shape Characteristics (1-2)
- All Structure/Materials Selection (1-4)
- All Deck Heights Selection (1-4)
- All Manning (1-4)

##### Basic Hull Structure Density

Symbol:  $W_{11+12+13+14}/\nabla_{\text{hull}}$  (lbs/ft<sup>3</sup>)

where  $W_{11}$  = shell and supporting structure

$W_{12}$  = hull structural bulkheads

$W_{13}$  = hull decks

$W_{14}$  = hull platforms and flats

Definition: Ratio of basic hull weight to hull volume.

Significance: Provides for information regarding the relative effect of hull weight and/or volume change. Driven by changes in ship size, loading, materials used, or survivability requirements.

Comparative analysis examines:

- All Size Characteristics (1-1)
- All Ship Performance Survivability (1-3)
- All Structure/Materials Subsystems Selections (1-4)

#### Deckhouse Structure Density

Symbol:  $W_{15}/\nabla_{dh}$  (lbs/ft<sup>3</sup>)

Definition: Ratio of deckhouse weight to deckhouse volume.

Significance: Provides for information regarding the relative effect of deckhouse weight and/or volume change. Driven by changes in deckhouse size, loading, materials used, or survivability requirements.

Comparative analysis examines:

- All Size Characteristics (1-1)
- All Ship Performance Survivability (1-3)
- All Structure/Materials Subsystems Selections (1-4)

#### Foundations Weight Fraction

Symbol:  $W_{18}/(W_{2+3+4+5+7})$

Definition: Fraction of foundation weight in relation to the sum of all non-structural weights.

Significance: Foundations and mountings are used for all equipment installed on the ship and their weights are directly affected by equipment sound insulation and shock requirements. The more stringent the requirements, the higher the fraction.

Comparative analysis examines:

- All Ship Performance Survivability (1-3)

#### Containment Cost/Weight Ratio

Symbol:  $C_c/W_{cf}$  (\$/ton)

Definition: Ratio of containment costs to full load containment weight as defined in screens 2-12 and 2-3.

Significance: Indicates cost per ton of containment portion of design. Driven by ship overall cost, size, manning and habitability requirements.

Comparative analysis examines:

- All Cost and Size Characteristics (1-1)
- All Shape Characteristics (1-2)
- All Manning (1-4)

#### SCREEN 3-3: MAIN PROPULSION BREAKDOWN

The main propulsion related parameters are further broken down into a more detailed analysis of weight and volume requirements.

- All Combat Systems selection (1-5)

#### Auxiliary Space Electric Volume Ratio

Symbol:  $V_{4.33}/V_e$

Definition: The fraction of total electric power volume requirement that is related to or located in the auxiliary machinery spaces. This includes any generators located in their own spaces and all 400Hz conversion equipment.

Significance: Dependent on size and rating of the electric plant, the size of the ship, and the combat systems installed.

Comparative analysis examines:

- Total Enclosed Volume (1-1)
- All HM&E Systems selection (1-4)
- All Combat Systems selection (1-5)

#### SCREEN 3-6: ELECTRICAL INDICES

##### ELECTRICAL DRIVERS:

The primary drivers of electrical power requirements are based on the "triple-plot" relationship:

$$W_3/\Delta_{f1} = (W_3/E_i) * (E_i/\Delta_{f1})$$

##### Electrical Weight Fraction

Symbol:  $W_3/\Delta_{f1}$

Definition: Fraction of full load displacement allocated to electrical related weight.

Definition: The fraction of total electric power weight that relates to power generation support systems.[22]

Significance: Function of the number, type and rating of generators installed.

Comparative analysis examines:

- HM&E electric power system selection (1-4)

#### VOLUME:

NOTE:  $V_e = V_{4.15} + V_{4.33}$

#### Machinery Space Electric Volume Ratio

Symbol:  $V_{4.15}/V_e$

Definition: The fraction of total electric power volume requirement that is related to or located in the main machinery spaces. It is noted that in the event that the electric generation plant is integrated to the propulsion plant it will be included with the propulsion plant indice.

Significance: Dependent on size and rating of the electric plant, the size of the ship, and the combat systems installed. A large fraction of electric generation in the machinery area will drive up the size of the machinery "large space" requirement.

Comparative analysis examines:

- Total Enclosed Volume (1-1)
- All HM&E Systems selection (1-4)

### Power Distribution Wt

Symbol:  $W_{32}/W_3$

Definition: The fraction of total electric power weight that relates to power distribution. This includes all cables, wireways and bustie feeders.[22]

Significance: Dependent on size and rating of the electric plant, the size of the ship, and the combat systems installed.

Comparative analysis examines:

- Total Enclosed Volume (1-1)
- All HM&E Systems selection (1-4)
- All Combat Systems selection (1-5)

### Lighting Wt Ratio

Symbol:  $W_{33}/W_3$

Definition: The fraction of total electric power weight that relates to lighting system distribution. This includes all distribution boxes, lighting panels and transformers.[22]

Significance: Dependent primarily on the volume of the ship.

Comparative analysis examines:

- Total Enclosed Volume (1-1)
- HM&E electric power system selection (1-4)

### Support System Wt Ratio

Symbol:  $W_{34+39}/W_3$

Significance: Indication of the cost per ton of the propulsion plant and is driven primarily by the size and complexity of the system. It should be noted that this cost will not include any government furnished HM&E equipment.

Comparative Analysis examines:

- All Main Propulsion HM&E Selections (1-4)

#### SCREEN 3-5: ELECTRICAL PLANT BREAKDOWN

The electrical plant parameters are further broken down into a more detailed analysis of weight and volume requirements.

#### **WEIGHT:**

##### **Power Generation Wt**

Symbol:  $W_{31}/W_3$

Definition: The fraction of total electric power weight that relates to power generation. This includes all primary sources of ship power, including emergency generators.[22]

Significance: Dependent on the type, number and size of generators installed, which is indirectly related to the volume, manning, machinery, and combat systems of the ship.

Comparative analysis examines:

- Total Enclosed Volume (1-1)
- All HM&E Systems selection (1-4)
- All Combat Systems selection (1-5)

Definition: Ratio of only transmission and propeller volume to shaft horsepower available.

Significance: Measure of the density of the volume required for the transmission system installed. Generally includes only the shaft alley, however may be significant for electric drive transmissions.

Comparative analysis examines:

- Ship Performance Mobility (1-3)
- Main Propulsion HM&E System selection (1-4)

#### Propulsion KW/Weight Ratio

Symbol:  $E_2/W_2$  (KW/ton)

Definition: Ratio of propulsion electric power requirements to the propulsion system weight.

Significance: Driven by the type of propulsion plant installed. Provides an indication of the electrical efficiency of the propulsion system.

Comparative analysis examines:

- Total 60Hz KW available/Max Load (1-4)
- All Main Propulsion HM&E Selection (1-4)

#### Propulsion Cost/Weight Ratio

Symbol:  $C_2/W_2$  (\$/ton)

Definition: Ratio of propulsion system basic construction cost to propulsion system weight.

### Propulsion & Trans Specific Volume

Symbol:  $V_{pt}/\text{SHP}$  ( $\text{ft}^3/\text{SHP}$ )

Definition: Ratio of the total propulsion and transmission systems volume to shaft horsepower available.

Significance: Measure of the density of the total mobility propulsion system installed. An increase in the ratio indicates less dense main engineering spaces. Recent designs have shown a consistency in this indice.

Comparative analysis examines:

- Ship Performance Mobility (1-3)
- Main Propulsion HM&E System selection (1-4)

### Propulsion Systems Specific Volume

Symbol:  $V_{4.1-4.15}/\text{SHP}$  ( $\text{ft}^3/\text{SHP}$ )

Definition: Ratio of only propulsion systems volume to shaft horsepower available.

Significance: Measure of the density of the propulsion system installed. An increase in the ratio indicates less dense main engineering spaces. Recent designs have shown a consistency in this indice.

Comparative analysis examines:

- Ship Performance Mobility (1-3)
- Main Propulsion HM&E System selection (1-4)

### Trans/Propeller Specific Volume

Symbol:  $V_{4.2}/\text{SHP}$  ( $\text{ft}^3/\text{SHP}$ )

**Definition:** Ratio of transmission and propeller weight to shaft horsepower available.

**Significance:** Measure of transmission and propeller weight to propulsion power efficiency. Fixed pitch propellers have a more efficient ratio than CRP propellers. See also "Main Propulsion Specific Weight" above.

**Comparative analysis examines:**

- Ship Performance Mobility (1-3)
- Main Propulsion HM&E System selection (1-4)

#### **Support/Fluids Specific Weight**

**Symbol:**  $W_{25+26+29}/SHP$  (lbs/SHP)

**Definition:** Ratio of propulsion support and fluids weight to shaft horsepower available. Includes all support air, piping, control and seawater systems, as well as fuel oil and lube oil systems.

**Significance:** Measure of propulsion support and fluids weight to propulsion power efficiency. Fully dependent on the requirements of the type of plant installed. Gas turbine plants have a better weight power efficiency than steam. See also "Main Propulsion Specific Weight" above.

**Comparative analysis examines:**

- Ship Performance Mobility (1-3)
- Main Propulsion HM&E System selection (1-4)

### Main Propulsion Volume Fraction

Symbol:  $V_{pt}/\nabla$

Definition:  $V_{pt} = V_{4.1+4.2-4.15}$

Volume fraction allocated to the main propulsion plant which includes the propulsion units and the transmission.

Significance: Driven by the size and type of propulsion plant installed.

Comparative analysis examines:

- Total Enclosed Volume (1-1)
- All Mobility Ship Performance (1-3)
- All Main Propulsion Selection (1-4)

### Propulsion Units Specific Weight

Symbol:  $W_{23}/SHP$  (lbs/SHP)

Definition: Ratio of propulsion units weight to shaft horsepower available.

Significance: Measure of propulsion unit weight to propulsion power efficiency. See also "Main Propulsion Specific Weight" above.

Comparative analysis examines:

- Ship Performance Mobility (1-3)
- Main Propulsion HM&E System selection (1-4)

### Transmission/Propeller Specific Weight

Symbol:  $W_{24}/SHP$  (lbs/SHP)

Taylor wake fraction, thrust deduction factor, propeller open water efficiency and relative rotative efficiency[17].

Significance: Direct affect on speed since it is an indicator of the efficiency of the propeller/hull interaction. It is desired to have the largest PC possible, thus increasing speed as PC increases.

Comparative analysis examines:

- All Hull Efficiency Ship Performance (1-3)
- Propeller Type/No./RPM (1-4)
- Propeller Open Water Efficiency (1-4)

#### RELATED MAIN PROPULSION RATIOS

##### Main Propulsion Density

Symbol:  $W_2/V_{pt}$  (lbs/ft<sup>3</sup>)

Definition: Ratio of SWBS Group 2 main propulsion weight to volume required for the propulsion plant.

Significance: Provides indication of spaciousness of the propulsion plant. The larger the fraction, the more tightly packed the propulsion plant is. Driven by speed, hull efficiency, type of plant, and survivability requirements. Gas turbines plants tend to be more spacious and thus have a smaller fraction than a steam plant.

Comparative analysis examines:

- All Mobility Ship Performance (1-3)
- Main Propulsion HM&E System selection (1-4)

**Significance:** Provides indication of hull hydrodynamic efficiency and is a function of the hullform selected. An increase in this parameter results in a decrease in speed.

**Comparative analysis examines:**

- Full load displacement (1-1)
- All Shape Characteristics (1-2)
- All Hull Efficiency Ship Performance (1-3)

#### **Drag to Displacement Ratio (sustained)**

**Symbol:**  $R_{Ts}/\Delta_{f1}$  (lbf/ton)

**Definition:** The drag, or resistance, of the hull at sustained speed as a fraction of the full load displacement.

**Significance:** Provides indication of hull hydrodynamic efficiency and is a function of the hullform selected. An increase in this parameter results in a decrease in speed. Allows for comparison of hydrodynamics at sustained speed versus endurance speed.

**Comparative analysis examines:**

- Full load displacement (1-1)
- All Shape Characteristics (1-2)
- All Hull Efficiency Ship Performance (1-3)

#### **Propulsion Coefficient**

**Symbol:** PC

**Definition:** Ratio of effective horsepower to delivered horsepower[10]. More rigidly defined as a function of the

Comparative analysis examines:

- Ship Performance Mobility (1-3)
- Main Propulsion HM&E System selection (1-4)

**Main Propulsion Ship Size Ratio**

Symbol:  $\text{SHP}/\Delta_{f1}$  (SHP/ton)

Definition: Ratio of shaft horsepower to full load displacement.

Significance: Shaft horsepower is the forcing parameter for the propulsion plant weight and volume. The decrease in installed power of recent ships has resulted in a decreasing trend in the last 40 years. The exception to the rule is the DDG-51 which is higher due to the overpowering required to compensate for its inefficient hullform.

Comparative analysis examines:

- Full Load Displacement (1-1)
- Ship Performance Mobility (1-3)
- Main Propulsion HM&E System selection (1-4)

**Drag to Displacement Ratio (endurance)**

Symbol:  $R_{Te}/\Delta_{f1}$  (lbf/ton)

Definition: The drag, or resistance, of the hull at endurance speed as a fraction of the full load displacement.

### Main Propulsion Weight Fraction

Symbol:  $W_2/\Delta_{f1}$

Definition: Fraction of full load displacement allocated to main propulsion.

Significance: An increase in this parameter will result in an increase in speed. Generally done by adding a larger propulsion plant, in effect, "brute-forcing" the increase.

Comparative analysis examines:

- Full Load Displacement (1-1)
- All Mobility Ship Performance (1-3)
- All Main Propulsion HM&E System Selection (1-4)

### Main Propulsion Specific Weight

Symbol:  $W_2/\text{SHP}$  (lbs/SHP)

Definition: Ratio of main propulsion weight to shaft horsepower available.

Significance: Measure of overall weight to propulsion power efficiency of the propulsion plant. A lower ratio indicates that the plant will provide more power for a given propulsion plant weight, which may allow for an increase in ship speed without an appreciable effect in displacement, or may allow for a decrease in the size of the plant. The recent change to gas turbine plants has resulted in a 10-15% decrease in specific weight.

Definition: Distribution of primary propulsion volumes as related to the total propulsion volume which is defined by:

$$V_{pt} = V_{4.1+4.2-4.15}$$

$V_{4.1}$  = Propulsion Systems

$V_{4.2}$  = Transmission and Propulsor

$V_{4.15}$  = Electric

Significance: Assists the designer in determining where the propulsion volume change occurred. Differences are a result of utilization of different propulsion subsystems.

Comparative analysis examines:

- all Main Propulsion HM&E System Selection (1-4)

#### SCREEN 3-4: MAIN PROPULSION INDICES

##### MAIN PROPULSION DRIVERS:

The primary drivers of main propulsion are based on the "triple plot" relationship:

$$W_2/\Delta_{f1} = (W_2/SHP) * (SHP/\Delta_{f1})$$

Since SHP can be related to drag and speed by:

$$SHP = (R_T * Speed) / PC$$

Speed can be derived to be a function of:

$$Spd = PC * 1/(R_T/\Delta_{f1}) * (W_2/\Delta_{f1}) * 1/(W_2/SHP)$$

Which relates speed, powering, efficiency and propulsion design practices.

**WEIGHT:**

Symbols:

Propulsion Units Wt	$W_{23}/W_2$
Transmission and Propulsor Wt	$W_{24}/W_2$
Propulsion Support System Wt	$W_{25+26+29}/W_2$
$W_{25}$ = Propulsion Support sys	
$W_{26}$ = Fuel/Lube Oil Support sys	
$W_{29}$ = Special Purpose Support	
Other Propulsion Weight	$W_{21+22}/W_2$
$W_{21}$ = Energy Generation (nuclear)	
$W_{22}$ = Energy Generation (non-nuc)	

Definition: Distribution of primary propulsion weights within Main Propulsion SWBS Group 2.

Significance: In comparison of a baseline to a variant, this section will assist in locating the source of the group 2 weight difference. Differences are a result of utilization of different propulsion systems.

Comparative analysis examines:

- all Main Propulsion HM&E System Selection (1-4)

**VOLUME:**

Symbols:

Propulsion Units Volume	$V_{4.1-4.15}/V_{pt}$
Transmission and Propulsor Volume	$V_{4.2}/V_{pt}$

**Significance:** Indicates to which extent the electrical system drives the design.

**Comparative analysis examines:**

- Full Load Displacement (1-1)
- All Electric Power HM&E System Selection (1-4)

#### **Electrical Specific Weight**

**Symbol:**  $W_3/E_i$  (lbs/KW)

**Definition:** Ratio of total electric plant weight to total installed electric power.

**Significance:** Measurement of the electric weight to KW efficiency of the plant. A lower ratio indicates that the plant has the capability of delivering more power for a given weight. Diesel electric generators generally have a higher specific weight than gas turbine generators.

**Comparative analysis examines:**

- All Electric power HM&E System Selection (1-4)

#### **Electrical Capacity Ship Size Ratio**

**Symbol:**  $E_i/\Delta_{f1}$  (KW/ton)

**Definition:** Ratio of installed electric power to full load displacement.

**Significance:** Impacted directly by ship size and is a function of the machinery and combat systems installed. The designs of the last 40 years have shown a consistent increase, primarily due to the increased emphasis on

electronics and weapons. Recent designs such as the DD-963 and DDG-51 have large electric plants providing a large future growth margin.

Comparative analysis examines:

- Full Load Displacement (1-1)
- All Electric power HM&E System Selection (1-4)

#### RELATED ELECTRICAL RATIOS:

##### Electrical Density

Symbol:  $W_3/V_e$  (lbs/ft<sup>3</sup>)

Definition: Ratio of SWBS Group 3 electrical plant weight to the required electric plant volume.

Significance: Provides indication of spaciousness of the electric plant. The capacity of electric power is driven by the volume of the ship, manning, machinery, and combat systems installed. The capacity then drives the size of the plant, which coupled with ship size then drive the electric density.

Comparative analysis examines:

- Total Enclosed Volume (1-1)
- All HM&E System Selection (1-4)
- All Combat System selection (1-5)

##### Electrical Volume Fraction

Symbol:  $V_e/\nabla$

Definition:  $V_e = V_{4.15} + V_{4.33}$

Volume allocation fraction of ship electrical power generation and distribution system. Note: earlier Navy SSCS versions used differing methods of storing electrical space allocation. The user must ensure that the data base ships he is using is consistent in this area.

Significance: Indicates how the design volume is driven by the electric power requirements. In general, ships with large or numerous combat systems tend to have a larger power demand.

Comparative analysis examines:

- Total Enclosed Volume (1-1)
- All Electric Power HM&E System Selections (1-4)
- All Combat System Selections (1-5)

#### Power Generation Specific Weight

Symbol:  $W_{31}/E_i$  (lbs/KW)

Definition: Ratio of that portion of the electric plant weight dedicated to electric power generation to the total electric power installed.

Significance: Measure of the electric generation weight to installed KW efficiency of the plant. The smaller the ratio, the less overall weight impact per KW.

Comparative analysis examines:

- All Electric power HM&E System Selection (1-4)

### Electrical Specific Volume

Symbol:  $V_e/E_i$  (ft<sup>3</sup>/KW)

Definition: Ratio of electric systems volume to the total installed electric power.

Significance: Measure of the density of the electric plant installed. An increase in the ratio indicates a more spacious electric plant.

Comparative analysis examines:

- All Electric power HM&E System Selection (1-4)

### Electrical System KW/Weight Ratio

Symbol:  $E_3/W_3$  (KW/ton)

Definition: Ratio of electrical system electric power requirements to the electrical system weight.

Significance: Driven by the type of electric plant installed. Provides an indication of the electrical efficiency of the electric plant.

Comparative analysis examines:

- Total 60Hz KW available/Max Load (1-4)
- All Electric Power HM&E Selection (1-4)

### Electrical System Cost/Weight Ratio

Symbol:  $C_3/W_3$  (\$/ton)

Definition: Ratio of electric plant basic construction cost to electric plant weight.

Significance: Indication of the cost per ton of the electric plant and is driven primarily by the size and complexity of the system. It should be noted that this cost will not include any government furnished HM&E equipment.

Comparative analysis examines:

- All Electric Power HM&E Selection (1-4)

SCREEN 3-7: AUXILIARY BREAKDOWN

WEIGHT:

Symbols:

Climate Control Wt	$W_{51}/W_5$
Sea Water/Freshwater System Wt	$W_{52+53}/W_5$
Fluid System Wt	$W_{54+55+59}/W_5$
Ship Control Wt	$W_{56}/W_5$
Replenishment/Mech Hndlg Wt	$W_{57+58}/W_5$

Definition: Further detailed distribution of auxiliary weight as a function of total auxiliary weight, SWBS Group 5.

Significance: Since many of the auxiliaries are distributed systems, the system size may vary due to changes in ship size, manning, machinery or combat systems.

Comparative analysis for all indices listed above examines:

- All Size Characteristics (1-1)
- All Auxiliary HM&E System Selection (1-4)

**VOLUME:**

NOTE:  $V_{ax} = V_{3.5+4.3-4.33}$

$V_{3.5}$  = Deck Systems

$V_{4.3}$  = Auxiliary Machinery

$V_{4.33}$  = Auxiliary Space Electric

**Deck Systems Volume**

Symbol:  $V_{3.5}/V_{ax}$

Definition: That portion of the auxiliary volume allocated to deck systems, which includes anchor and line handling, transfer-at-sea and ships boats.[23]

Significance: Driven primarily by the type of systems installed.

Comparative analysis examines:

- All Auxiliary HM&E System Selection (1-4)

**Auxiliary Machinery Volume fraction**

Symbol:  $(V_{4.3}-V_{4.33})/V_{ax}$

Definition: That portion of auxiliary volume allocated to auxiliary machinery. This includes all HVAC, refrigeration, pollution control and propulsion machinery related mechanical systems.[23]

Significance: Distributed systems depend on ship size, combat systems and manning. Machinery related systems are dependent on type and size of propulsion plant.

Comparative analysis examines:

- Main Propulsion HM&E System Selection (1-4)
- Auxiliary HM&E System Selection (1-4)
- Manning HM&E System Selection (1-4)

### SCREEN 3-8: AUXILIARY INDICES

#### AUXILIARY DRIVERS:

The primary drivers of auxiliary are based on the "triple plot" relationship:

$$W_5/\Delta_{f1} = (W_5/\nabla) * (\nabla/\Delta_{f1})$$

#### Auxiliary Weight Fraction

Symbol:  $W_5/\Delta_{f1}$

Definition: The fraction of full load displacement allocated to auxiliaries.

Significance: Indicates the extent to which auxiliaries drive the design weight.

Comparative analysis examines:

- Full Load Displacement (1-1)
- All Auxiliary HM&E System Selection (1-4)

#### Auxiliary Specific Weight

Symbol:  $W_5/\nabla$  (lbs/ft<sup>3</sup>)

Definition: Ratio of main auxiliary weight to overall ship volume.

Significance: Provides indication of auxiliary weight impact on overall ship volume. Due to the fact that much of the auxiliaries are distributed systems, the indice is a function of type and rating of auxiliary systems used, as well as ship size, manning and combat systems installed.

Comparative analysis examines:

- All Size Characteristics (1-1)
- All Auxiliary HM&E System Selection (1-4)

#### Ship Specific Volume

Symbol:  $\nabla/\Delta_{f1}$  (ft<sup>3</sup>/ton)

Definition: Ratio of total enclosed volume to full load displacement.

Significance: Indication of spaciousness and how the volume drives the design. The larger the specific volume, the more spacious the design is. Recent trends have been toward an increase in specific volume. As the spaciousness increases, the associated weight fraction also increases.

Comparative analysis examines:

- All Size Characteristics (1-1)
- All Shape Characteristics (1-2)

#### RELATED AUXILIARY RATIOS:

##### Auxiliary Density

Symbol:  $W_5/V_{ax}$  (lbs/ft<sup>3</sup>)

Definition: Ratio of SWBS Group 5, auxiliaries weight, to related auxiliaries volume.

Significance: Provides indication of the spaciousness of the auxiliaries installed. Many of the auxiliaries are distributed systems and are therefore driven by ship size, manning, machinery and combat systems installed.

Comparative analysis examines:

- All Size Characteristics (1-1)
- All Auxiliary HM&E System Selection (1-4)

#### Auxiliary Volume Fraction

Symbol:  $V_{ax} / \nabla$

Definition: Volume fraction allocated to the auxiliary systems, which include deck systems and auxiliary machinery systems but do not include auxiliary electrical power generation spaces.

Significance: Indicates the extent to which auxiliary volume drives the design.

Comparative analysis examines:

- Total Enclosed Volume (1-1)
- All Auxiliary HM&E System Selections (1-4)

#### Auxiliary System KW/Weight Ratio

Symbol:  $E_5 / W_5$  (KW/ton)

Definition: Ratio of installed auxiliary system electric power requirements to the auxiliary system weight.

**Significance:** Driven by the type of auxiliaries installed.

Provides an indication of the electrical efficiency of the installed auxiliaries. Recent trends has been to go to more gas turbine ships which has resulted in less available steam, thereby requiring more electric auxiliaries. A gas turbine plant will, therefore, have a higher fraction than a steam plant.

**Comparative analysis examines:**

- Total 60Hz KW available/Max Load (1-4)
- All Auxiliaries HM&E Selection (1-4)

#### **Auxiliary Cost/Weight Ratio**

**Symbol:**  $C_3/W_3$  (\$/ton)

**Definition:** Ratio of auxiliaries basic construction cost to the auxiliary plant weight.

**Significance:** Indication of the cost per ton of the auxiliary plant and is driven primarily by the size and complexity of the system. It should be noted that this cost will not include any government furnished HM&E equipment.

**Comparative analysis examines:**

- All Electric Power HM&E Selection (1-4)

### SCREEN 3-9: COMBAT SYSTEMS BREAKDOWN

This screen serves to break down the combat systems weight and volume to provide the user the ability to analyze which part of the combat system is driving the design.

#### COMBAT SYSTEMS WEIGHT:

$$\text{Note: } W_{csf} = W_4 + W_7 + W_{ord} + W_{av}$$

#### Command and Surveillance Weight

Symbol:  $W_4/W_{csf}$

Definition: Ratio of the command and surveillance weight to the weight of the total combat system.

Significance: Provides an indication of the extent that command and surveillance drives the combat system, and ultimately the design.

Comparative analysis examines:

- All Sensors in each Warfare Area (1-5)
- All Command, Control, Comm and Intel Warfare Area (1-5)

#### Armament Weight

Symbol:  $W_7/W_{csf}$

Definition: Ratio of the armament weight to the weight of the total combat system.

Significance: Provides an indication of the extent that armament drives the combat system, and ultimately the design.

Comparative analysis examines:

- All Armament in each Warfare Area (1-5)

#### Aviation Weight

Symbol:  $w_{av}/w_{csf}$

Definition: Ratio of the aviation related weight to the weight of the total combat system.

Significance: Provides an indication of the extent that the aviation detachment drives the combat system, and ultimately the design.

Comparative analysis examines:

- All Aviation Capabilities in each Warfare Area (1-5)

#### Ordnance Weight

Symbol:  $w_{ord}/w_{csf}$

Definition: Ratio of the load ordnance weight to the weight of the total combat system.

Significance: Provides an indication of the extent that the load ordnance drives the combat system.

Comparative analysis examines:

- All Armament in each Warfare Area (1-5)

#### COMMAND AND SURVEILLANCE WEIGHT:

Symbols:

Interior/Exterior Communications Wt  $w_{43+44}/w_4$

Surface Surveillance Wt  $w_{45}/w_4$

Underwater Surveillance Wt

$W_{46}/W_4$

Other C&S Wt

$W_{41+42+47+48+48}/W_4$

Definition: Percentage of command and surveillance weight allocated to each of its major functions.

Significance: Provides the user an indication of the extent to which a major command and surveillance function drives the command and surveillance package installed in the design.

Comparative analysis examines:

- All Sensors in each Warfare Area (1-5)
- All Command, Control, Comm and Intel Warfare Area (1-5)

#### ARMAMENT WEIGHT:

Symbols:

Guns and Ammo Wt

$W_{71}/W_7$

Missiles and Rockets Wt

$W_{72}/W_7$

Other Armament Wt

$W_{73}$  thru  $W_{79}/W_7$

Definition: Percentage of armament weight allocated to each of its major functions.

Significance: Provides the user an indication of the extent to which a major armament category drives the armament function.

Comparative analysis examines:

- All Armament of each Warfare Area (1-5)

## COMBAT SYSTEMS VOLUME:

### Command and Surveillance Volume

Symbol:  $V_{1.1}/V_1$

Definition: Percentage of total mission support volume allocated to command and surveillance.

Significance: Indicates how much the command and surveillance function drives the total mission support.

Comparative analysis examines:

- All Sensors in each Warfare Area (1-5)
- All Command, Control, Comm and Intel Warfare Area (1-5)

### Armament Volume

Symbol:  $V_{1.2}/V_1$

Definition: Percentage of total mission support volume allocated to armament.

Significance: Indicates how much the installed armament drives the total mission support.

Comparative analysis examines:

- All Armament in each Warfare Area (1-5)

### Aviation Volume

Symbol:  $V_{1.3}/V_1$

Definition: Percentage of total mission support volume allocated to aviation capability.

Significance: Indicates how much the aviation detachment drives the total mission support.

Significance: Includes flag accommodations and transient berthing, if installed. Directly impacted by the habitability standard assigned to the ship and the number of officers required for the subsystems installed.

Comparative analysis examines:

- All Deck Heights in HM&E System Selection (1-4)
- All Manning in HM&E System Selection (1-4)

#### CPO Living Area per man

Symbol:  $A_{2.12+2.212/M_{acpo}}$  (ft<sup>2</sup>/man)

Definition: Ratio of area allocated to Chief Petty Officer berthing, sanitary, recreation and messing to the number of CPO accommodations.

Significance: Includes flag accommodations and transient berthing, if installed. Directly impacted by the habitability standard assigned to the ship and the number of CPO's required for the equipment installed.

Comparative analysis examines:

- All Deck Heights in HM&E System Selection (1-4)
- All Manning in HM&E System Selection (1-4)

#### Enlisted Living Area per man

Symbol:  $A_{2.13+2.213/M_{aenl}}$  (ft<sup>2</sup>/man)

Definition: Ratio of area allocated to enlisted berthing, sanitary, recreation and messing to the number of enlisted accommodations.

Comparative analysis examines:

- All Manning in HM&E System Selection (1-4)

#### Human Support Specific Area

Symbol:  $A_2/M_a$  (ft<sup>2</sup>/man)

Definition: Ratio of area allocated to human support to the number of accommodations.

Significance: Since volume is also affected by deck height, this indice provides a more realistic "amount of space" allocated to each accommodation. It may show the designer how much future expansion could be performed. In fact, the recent designs of FFG-7 and DD-963 used some of the large human support specific area initially installed to expand the manning they could support. The U.S. Navy 1979 standard of 45 ft<sup>2</sup>/man was exceeded in both of these designs.

Comparative analysis examines:

- All Deck Heights in HM&E System Selection (1-4)
- All Manning in HM&E System Selection (1-4)

#### Officer Living Area per man

Symbol:  $A_{2.11+2.211}/M_{aoff}$  (ft<sup>2</sup>/man)

Definition: Ratio of area allocated to officer berthing, sanitary, recreation and messing to the number of officer accommodations.

the design is. Driven primarily by manning and habitability standards used.

Comparative analysis examines:

- All Manning in HM&E System Selection (1-4)

#### Personnel Living Space Specific Vol

Symbol:  $V_{2.1}/M_a$  (ft<sup>3</sup>/man)

Definition: Ratio of volume assigned specifically to personnel berthing, sanitation, and recreation to the total manning accommodations.

Significance: A more concise representation of spaciousness of the design per man, which directly impacts the crew as space specifically assigned to them.

Comparative analysis examines:

- All Manning in HM&E System Selection (1-4)

#### Human Support Specific Volume

Symbol:  $V_2/M_a$  (ft<sup>3</sup>/man)

Definition: Ratio of human support allocated volume to the total number of accommodations.

Significance: Direct function of habitability standards and total manning assigned. The trend in the last 40 years has consistently increased to the point where it has almost tripled. The recent DDG-51 design has used a more efficient, compact arrangement to bring this ratio back down.

available for training and maintenance. This indice is therefore an indication of the efficiency of personnel requirements.

Comparative analysis examines:

- All Manning in HM&E System Selection (1-4)

#### Total Accomodations Ship Size Ratio

Symbol:  $M_a/\Delta_{f1}$  (men/1000 tons)

Definition: Ratio of total manning accomodations to full load displacement.

Significance: Provides an indication of efficiency of manning and amount of automatic controls and minimized maintenance requirements. The lower the indice, the more efficient the design from a manning perspective.

Comparative analysis examines:

- Full Load Displacement (1-1)
- All Manning in HM&E System Selection (1-4)

#### RELATED HUMAN SUPPORT RATIOS:

##### Human Support Density

Symbol:  $w_{HS}/V_2$  (lbs/ft<sup>3</sup>)

Definition: Ratio of total human support weight to human support volume.

Significance: Provides indication of human support spaciousness. The smaller the fraction, the more spacious

Comparative analysis examines:

- All Manning in HM&E System Selection (1-4)

### SCREEN 3-12: HUMAN SUPPORT INDICES

#### HUMAN SUPPORT DRIVERS:

Drivers are those related to the "triple plot" relationship:

$$W_{HS}/\Delta_{f1} = (W_{HS}/M_a) * (M_a/\Delta_{f1})$$

where the individual parameters are as defined in screen 3-11.

#### Human Support Weight Fraction

Symbol:  $W_{HS}/\Delta_{f1}$

Definition: Percentage of full load displacement allocated to the function of human support.

Significance: Directly related to manning size and habitability standards.

Comparative analysis examines:

- Full Load Displacement (1-1)
- All Manning in HM&E System Selection (1-4)

#### Human Support Specific Weight

Symbol:  $W_{HS}/M_a$  (tons/man)

Definition: Ratio total human support weight to total complement of manning.

Significance: Manning level is established by the ship requirements at Condition III, which is underway with selected combat systems energized, with personnel still

$W_{6cr}$  = crew related group & outfit and furnishings

$$(W_{6cr} = W_{64+65+66+67})$$

$W_{pw}$  = potable water weight (F52)

**Symbols:**

Crew and Effects Weight  $W_{ce}/W_{HS}$

Outfit and Furnishings Weight  $W_{6cr}/W_{HS}$

Potable Water Weight  $W_{pw}/W_{HS}$

**Definition:** Percentage of human support weights allocated to the primary human support loads.

**Significance:** Direct function of manning and habitability standards of the design.

**Comparative analysis examines:**

- All Manning in HM&E Selection (1-4)

**VOLUME:**

**Symbols:**

Living Volume  $V_{2.1}/V_2$

Food Service/Messroom/Lounge Volume  $V_{2.2}/V_2$

Medical/General Svcs/Other Vol  $V_{2.3}$  thru  $2.7/V_2$

**Definition:** Percentage of the total human support volume allocated to its primary users.

**Significance:** Direct function of manning and habitability standard of the design and an indirect function of ship volume.

Significance: Driven by the size and complexity of the combat system. Provides an indication of electrical efficiency of the combat system.

Comparative analysis examines:

- Total 60Hz KW Available/Max Load (1-4)
- All Combat Systems Selection (1-5)

#### Combat System Cost/Weight Ratio

Symbol:  $C_{CS}/W_{CSf}$  (\$/ton)

Definition: Ratio of combat system costs to full load combat system weight as defined in screens 2-12 and 2-3 respectively.

Significance: Indication of cost per ton of the combat system. Driven primarily by the size and complexity of the combat system installed.

Comparative analysis examines:

- All Combat Systems Selection (1-5)

#### SCREEN 3-11: HUMAN SUPPORT BREAKDOWN

$M_a$  = total accommodations

$M_{axxx}$  = accommodations for 'xxx' personnel

#### WEIGHT:

$$W_{HS} = W_{ce} + W_{ocr} + W_{pw}$$

$W_{HS}$  = total human support weight

$W_{ce}$  = crew and effects load weight (F1)

Significance: Provides indication of spaciousness of the command and surveillance package of the design. The larger the fraction the more tightly packed the C&S system is. Driven primarily by the type and complexity of the command and surveillance equipment installed.

Comparative analysis examines:

- All Sensors in each Warfare Area (1-5)

#### Armament Density

Symbol:  $W_7/V_{1,2}$  (lbs/ft<sup>3</sup>)

Definition: Ratio of SWBS group 7 armament weight to armament volume.

Significance: Provides indication of spaciousness of armament systems in the design. The larger the fraction the more tightly packed the armament systems are. Driven primarily by the type and complexity of the armament installed.

Comparative analysis examines:

- All Armament in each Warfare Area (1-5)

#### Combat System KW/Weight Ratio

Symbol:  $E_{CS}/W_{CSf}$  (KW/ton)

Definition: Ratio of combat system KW requirements to the full load combat system weight as defined in screens 2-8 and 2-3 respectively.

Significance: Provides some analysis of the weight efficiency of the sensors carried, thereby determining the impact of the command and surveillance package on the ship on a "per sensor" basis.

Comparative analysis examines:

- All Sensors in each Warfare Area (1-5)

#### RELATED COMBAT SYSTEMS RATIOS:

##### Combat Systems Density

Symbol:  $W_{CSF}/V_1$  (lbs/ft<sup>3</sup>)

Definition: Ratio of total combat systems weight to mission support combat systems volume.

Significance: Provides indication of spaciousness and/or size of the combat system of the design. The larger the fraction the more tightly packed the combat system is. Driven primarily by the type and complexity of the combat systems installed.

Comparative analysis examines:

- All Combat Systems Selection (1-5)

##### Command and Surveillance Density

Symbol:  $W_4/V_{1.1}$  (lbs/ft<sup>3</sup>)

Definition: Ratio of SWBS group 4 command and surveillance weight to command and surveillance volume.

Definition: The ratio of sensors per 1000 tons of full load displacement. In computing the number of sensors, each major sensor is counted as one unit. This includes radar, sonar, and EW systems. The communications suite is counted as one unit, irrespective of size. A fire control system is not counted as a sensor since it is associated with a launcher system. The helo capability is not classified a sensor since it may or may not be aboard at any given time. To be classified a sensor, a unit must be able to transmit, detect, track or classify something external to the ship.

Significance: A method of comparing the efficiency of a design by comparing its sensor capability. The greater the fraction, the more efficient the design from the perspective of ability to detect, track and communicate with other units.

Comparative analysis examines:

- All Sensors in each Warfare Area (1-5)

#### C&S Specific Weight

Symbol:  $W_4/\#s$  (1000 tons/sensor)

Definition: Ratio of total command and surveillance weight, as defined by SWBS group 4, to the number of installed sensors, where the number of sensors is as defined in "C&S Capacity Size Ratio" above.

### Armament Specific Weight

Symbol:  $W_7/\#1$  (1000 tons/launcher)

Definition: Ratio of total armament weight, as defined by SWBS group 7, to the number of launchers, where the number of launchers is as defined in "Armament Capacity Size Ratio" above.

Significance: Provides some analysis of the weight efficiency of the weapons carried, thereby determining the impact of the weapons on the ship on a "per weapon" basis.

Comparative analysis examines:

- All Armament in each Warfare Area (1-5)

### C&S Weight Fraction

Symbol:  $W_4/\Delta_{f1}$

Definition: Fraction of full load displacement allocated to command and surveillance.

Significance: Indicates the extent to which the command and surveillance system drives the full load weight of the design.

Comparative analysis examines:

- Full Load Displacement (1-1)
- All Sensors in each Warfare Area (1-5)
- All Command, Control, Comm & Intel (1-5)

### C&S Capacity Size Ratio

Symbol:  $\#s/\Delta_{f1}$  (sensors/1000tons)

### Armament Capacity Size Ratio

Symbol:  $\#l/\Delta_{f1}$  (lchr/1000tons)

Definition: The ratio of launchers per 1000 tons of full load displacement. In computing the number of launchers, each unit capable of launching a weapon is considered one launcher. In the case where multiple fire capability exists, the criteria shall be how many targets can it lock on and fire at simultaneously. If only one weapon can leave the launcher at a time, then it is one unit. Therefore, VLS is one unit, irrespective of how many cells it has. Harpoon is one unit since it can only fire one at a time, even though there may exist two canister sets. Torpedoes are considered one unit. Each gun is one unit, each CIWS-set (one or two) is considered one unit, small arms are not counted. Helos are not counted since they are not a permanent part of the ship and may or may not be aboard at any given time.

Significance: Since many comparisons are performed by comparing the weapons systems of the design, this provides an indication of armament carrying capacity and efficiency of the design. The greater the fraction, the more efficient the design from the perspective of ability to fight.

Comparative analysis examines:

- All Armament in each Warfare Area (1-5)

Significance: Provides the user an indication of the extent to which a major armament category drives the armament function.

Comparative analysis examines:

- All Armament of each Warfare Area (1-5)

### SCREEN 3-10: COMBAT SYSTEMS INDICES

#### COMBAT SYSTEM DRIVERS

The combat system is driven by parameters of the set of "triple plots" for C&S and armament:

$$W_4/\Delta_{f1} = (W_4/\#s) * (\#s/\Delta_{f1})$$

$$W_7/\Delta_{f1} = (W_7/\#1) * (\#1/\Delta_{f1})$$

where #1 = number of launchers installed

#s = number of sensors installed

#### Armament Weight Fraction

Symbol:  $W_7/\Delta_{f1}$

Definition: Fraction of full load displacement allocated to armament.

Significance: Indicates the extent to which the armament installed drives the full load weight of the design.

Comparative analysis examines:

- Full Load Displacement (1-1)
- All Armament in each Warfare Area (1-5)

Comparative analysis examines:

- All Aviation Capabilities in each Warfare Area (1-5)

**COMMAND AND SURVEILLANCE VOLUME:**

Symbols:

Interior/Exterior Comm Vol  $V_{1.11+1.15}/V_{1.1}$

Surface Surveillance Vol  $V_{1.121}/V_{1.1}$

Underwater Surveillance Vol  $V_{1.122}/V_{1.1}$

Other C&S Volume  $V_{1.13+1.14+1.16}/V_{1.1}$

Definition: Percentage of command and surveillance volume allocated to each of its major functions.

Significance: Provides the user an indication of the extent to which a major command and surveillance function drives the command and surveillance package installed in the design.

Comparative analysis examines:

- All Sensors in each Warfare Area (1-5)
- All Command, Control, Comm and Intel Warfare Area (1-5)

**ARMAMENT VOLUME:**

Symbols:

Guns and Ammo Volume  $V_{1.21}/V_{1.2}$

Missiles and Rockets Volume  $V_{1.22+1.23}/V_{1.2}$

Other Armament Volume  $V_{1.24+1.25+1.26+1.27}/V_{1.2}$

Definition: Percentage of armament volume allocated to each of its major functions.

Significance: Includes flag accommodations and transient berthing, if installed. Directly impacted by the habitability standard assigned to the ship and the number of enlisted personnel to operate and maintain the equipment installed.

Comparative analysis examines:

- All Deck Heights in HM&E System Selection (1-4)
- All Manning in HM&E System Selection (1-4)

#### Officer Ship Size Ratio

Symbol:  $M_{aoff}/\Delta_{f1}$  (men/1000 tons)

Definition: Ratio of officer accommodations to full load displacement.

Significance: Provides indication of efficiency of design with respect to manning accommodations per tonnage. The smaller the value, the more efficient usage of personnel assigned.

Comparative analysis examines:

- Full Load Displacement (1-1)
- All Manning in HM&E System Selection (1-4)

#### CPO Ship Size Ratio

Symbol:  $M_{acpo}/\Delta_{f1}$  (men/1000 tons)

Definition: Ratio of CPO accommodations to full load displacement.

Significance: Provides indication of efficiency of design with respect to manning accommodations per tonnage. The smaller the value, the more efficient usage of personnel assigned.

Comparative analysis examines:

- Full Load Displacement (1-1)
- All Manning in HM&E System Selection (1-4)

#### Enlisted Ship Size Ratio

Symbol:  $M_{aen1}/\Delta_{f1}$  (men/1000 tons)

Definition: Ratio of enlisted crew accommodations to full load displacement.

Significance: Provides indication of efficiency of design with respect to manning accommodations per tonnage. The smaller the value, the more efficient usage of personnel assigned.

Comparative analysis examines:

- Full Load Displacement (1-1)
- All Manning in HM&E System Selection (1-4)

#### SCREEN 3-13: MARGIN SUMMARY

This screen serves as a summary screen to display ships margins and allow comparisons to the NAVSEA standards.

Definition: Two types of margins are examined. The first, "acquisition margin" relates to the design practice of accounting for uncertainties in design and construction. A completed ship will no longer have an acquisition margin. The second margin is the "service life margin"

which allocates for anticipated changes expected during the ship's normal operational service. In general, these margins can be explained by considering three phases of a ship design for each of the below indices, the "current" value at a particular stage of design, the anticipated "delivery" value and the absolute "limit". It is the difference between the "delivery" and "current" value that makes up the acquisition margin and the difference between the "limit" and "delivery" that is classified as service life.

**Significance:** The user should examine both designs for the use of standard margins. The use of standard margins in one design and not in the other may result in a significant impact in the design indice area. Additionally, the user may get a good appreciation for "excessive" margins which directly impact a design.

Since design margins are selected by the design team, they are a function of a given design. Therefore, no comparative analysis path exists for them in this level.

Each indice is further explained below. All margins are converted to percentages for use in this screen.

#### Weight[29]

Acquisition Margin:

Symbol:  $W_m / (\Delta_{15} - W_m)$

Definition: The ratio of the acquisition margin to the sum of the weights of SWBS groups 1 through 7. In this study, the light ship weight is the sum of these SWBS groups plus the margin.

$$\text{- NAVSEA Standard} \quad .1 * (\Delta_{1s} - W_m) = 10\%$$

Service Life Margin:

$$\text{Symbol: } (\Delta_{a1} - \Delta_{f1}) / \Delta_{f1}$$

Definition: The ratio of the architectural weight limit minus the full load delivery displacement to the full load displacement.

$$\text{- NAVSEA Standard} \quad .1 * \Delta_{f1} = 10\%$$

#### KG[29]

Acquisition Margin:

$$\text{Symbol: } KG_m / KG_{1s}$$

Definition: Ratio of the KG acquisition margin to the light ship KG

$$\text{- NAVSEA Standard} \quad .1 * KG_{1s} = 10\%$$

Service Life Margin:

$$\text{Symbol: } (KG_{a1} - KG_{f1}) / KG_{f1}$$

Definition: Ratio of the architectural limit KG minus delivery full load KG to the full load KG.

$$\text{- NAVSEA Standard} \quad KG_{a1} - KG_{f1} = 1.0 \text{ ft}$$

## Electric Power[28]

General Symbols:  $E_g$  = KW rating of one generator

$E_{am}$  = Acquisition Margin

$E_{slm}$  = Service Life Margin

$$= (.9 * (E_i - E_g)) - (E_t + E_{am})$$

$$E_m = E_{am} + E_{slm} - E_2$$

Acquisition Margin:

Symbol:  $E_{am}/E_t$

Definition: Ratio of electric power acquisition margin to maximum functional load.

$$\text{- NAVSEA Standard} \quad .2 * E_t = 20\%$$

Service Life Margin:

Symbol:  $E_{slm}/(E_t + E_m)$

Definition: This margin excludes one of the generators which must remain in standby as an emergency generator. The remaining generators must not exceed 90% of their available installed load capability. If an acquisition margin is still being used in the design process then it is considered to be a part of the maximum functional load since it is by definition for design and construction uncertainties. There is no service life margin for the propulsion plant since it is not expected to grow electrically in the life of the ship. It is therefore subtracted from the full capacity when computing margin.

$$\text{- NAVSEA Standard} \quad .2 * (E_t + E_m) = 20\%$$

## Volume

### Service Life Margin:

Symbol:  $V_5 / \nabla$

Definition: SSCS  $V_5$  is the volume that is not assigned in the ship. Although it is not a true margin, it is space that is available for future growth. It is the policy of NAVSEA that all space is to be allocated.

- NAVSEA Standard 0%

## Manning

### Service Life Margin:

Symbol:  $(M_a - M_t) / M_t$

Definition: The ratio of the difference between the manning complement and the accommodations installed to the total manning complement.

- NAVSEA Standard  $.1 * M_t = 10\%$

**END**

**FILMED**

**11-85**

**DTIC**