

UNCLASSIFIED

SECURITY CLASSIFICATION OF THIS PAGE (When Data Entered)

20030115145

REPORT DOCUMENTATION PAGE

READ INSTRUCTIONS BEFORE COMPLETING FORM

|  |  |                       |   |                               |  |
|--|--|-----------------------|---|-------------------------------|--|
| 1. REPORT NUMBER   |  | 2. GOVT ACCESSION NO. |   | 3. RECIPIENT'S DATA OR NUMBER |  |
| TOP 10-2-155   |  |                       |   |                               |  |
| 4. TITLE (and Subtitle)  |  |                       | 5. TYPE OF REPORT & PERIOD COVERED                          |                               |  |
| U.S. ARMY TEST AND EVALUATION COMMAND<br>TEST OPERATIONS PROCEDURE<br>"FLAMMABILITY TESTS OF MILITARY SHELTERS"  |  |                       | Final   |                               |  |
| 7. AUTHOR(s)   |  |                       | 6. PERFORMING ORG. REPORT NUMBER                            |                               |  |
|  |  |                       |   |                               |  |
| 9. PERFORMING ORGANIZATION NAME AND ADDRESS  |  |                       | 10. PROGRAM ELEMENT, PROJECT, TASK AREA & WORK UNIT NUMBERS |                               |  |
| U.S. ARMY COMBAT SYSTEMS TEST ACTIVITY (STECs-AD-A)<br>ABERDEEN PROVING GROUND, MARYLAND 21005-5059  |  |                       | AMCR-R 310-6  |                               |  |
| 11. CONTROLLING OFFICE NAME AND ADDRESS  |  |                       | 12. REPORT DATE   |                               |  |
| U.S. ARMY TEST AND EVALUATION COMMAND (AMSTE-AD-M)<br>ABERDEEN PROVING GROUND, MARYLAND 21005-5055   |  |                       | 9 September 1985  |                               |  |
|  |  |                       | 13. NUMBER OF PAGES   |                               |  |
|  |  |                       |   |                               |  |
| 14. MONITORING AGENCY NAME & ADDRESS (if different from Controlling Office)  |  |                       | 15. SECURITY CLASS. (of this report)                        |                               |  |
|  |  |                       | Unclassified  |                               |  |
|  |  |                       | 15a. DECLASSIFICATION/DOWNGRADING SCHEDULE                  |                               |  |
|  |  |                       |   |                               |  |
| 16. DISTRIBUTION STATEMENT (of this Report)  |  |                       |   |                               |  |
| Approved for public release; distribution unlimited.   |  |                       |   |                               |  |
| 17. DISTRIBUTION STATEMENT (of the abstract entered in Block 20, if different from Report)   |  |                       |   |                               |  |
|  |  |                       |   |                               |  |
| 18. SUPPLEMENTARY NOTES  |  |                       |   |                               |  |
|  |  |                       |   |                               |  |
| 19. KEY WORDS (Continue on reverse side if necessary and identify by block number)   |  |                       |   |                               |  |
| Flammability Tests<br>Military Shelters,<br>Shelters   |  |                       |   |                               |  |
| 20. ABSTRACT (Continue on reverse side if necessary and identify by block number)  |  |                       |   |                               |  |
| Provides procedures for tests to determine fire hazard characteristics of metal-faced foam core shelter material. Includes flame spread and fuel-contributed test, and susceptibility-to-radiant-heat damage test. <span style="float: right;">p. 1</span> |  |                       |   |                               |  |

AD-A159 150

DTIC FILE COPY

f. lock

DTIC

SEP 17 1985



2. FACILITIES AND INSTRUMENTATION.2.1 Facilities.

| <u>ITEM</u> | <u>REQUIREMENT</u>  |
|-------------|---------------------|
| Calorimeter | refer to Appendix A |
| Test oven   | refer to Appendix A |

2.2 Instrumentation.

| <u>ITEM</u>   | <u>PERMISSIBLE ERROR<br/>OF MEASUREMENT*</u> |
|---|--|
| Device to measure and record<br>16 thermocouple outputs | $\pm 1\%$ of reading                         |
| Plotter to record time versus<br>temperature            | $\pm 0.3\%$ of recorded value                |

3. REQUIRED TEST CONDITIONS.3.1 Flame Spread and Fuel Contribution.

a. Test Sample. The test sample, measuring approximately 1.4x1.5m (4-1/2 by 5 ft), must be representative of the material or assembly for which classification is desired, as to ingredients, workmanship, and practical application as established by shelter construction.

## b. Calibration.

(1) Install the refractory cover and adjust combustion air to 38°C (100°F).

(2) Preheat furnace until the thermocouples embedded in the brick lining of the calorimeter record 150°C (300°F).

(3) At this time, cut off the preheat, maintain combustion air at 38°C, and cool the calorimeter until the embedded thermocouples attain 80°C (175°F).

(4) Start the exposure fire and adjust to a fixed rate of either 17,700 Btu/min maintained for 10 minutes, or 26,500 Btu/min maintained for 30 minutes. The 10-minute exposure time is used for interior finish wall material, whereas the 30-minute exposure time is used for composite roof material. Plot a time-versus-temperature curve from the flue thermocouple output during the 10-minute exposure period. Repeat (3) and (4) three times to establish standardization curves for verifying calorimeter precision. A typical standardization curve is provided as Figure 1.

\*The permissible error of measurement for instrumentation is the two-sigma value for a normal distribution; thus, the stated errors should not be exceeded in more than 1 measurement of 20.

# INTERIOR FINISH MATERIALS, 10 MINUTES

STANDARD EXPOSURE CURVE

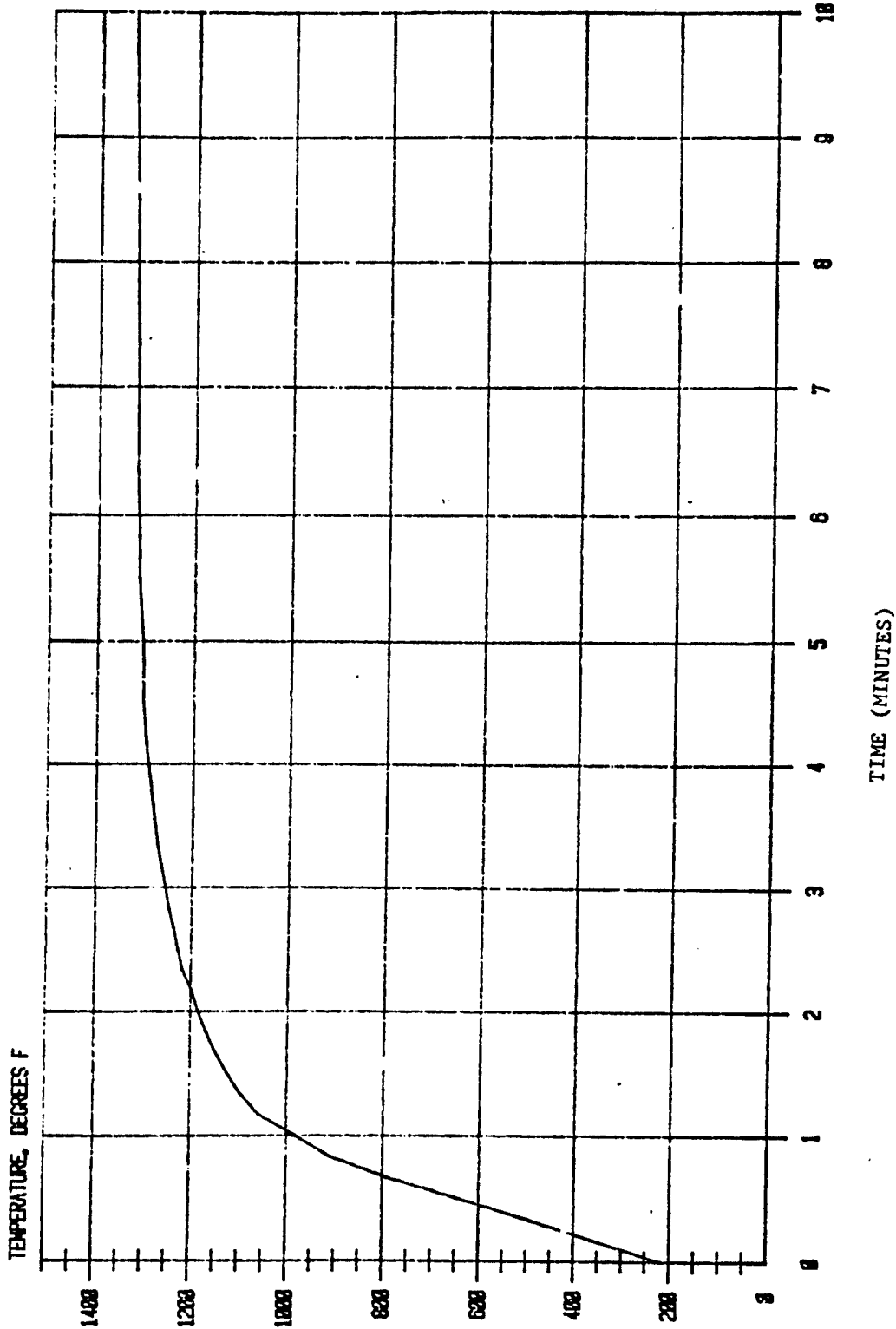

Figure 1. Typical standardization curve.

### 3.2 Susceptibility to Heat Damage.

a. Test sample. Place the test sample, measuring about 40x40cm; 2cm minimum thickness (16 by 16 in.; 3/4-in. minimum thickness) on a 40x40cm, 20-gage-thick steel sheet. The steel sheet is used to prevent the sample from falling into the test furnace. This procedure pertains to para 4.3 below. For more information, see reference 1.

b. Calibration. Calibrate the test oven by adjusting the fuel control valve so that the temperature recorded on the thermocouple is 2.5cm below the test sample records 218°C (425°F), 246°C (475°F), and 260°C (500°F). Record the valve position for each corresponding temperature.

## 4. TEST PROCEDURES.

### 4.1 Flame Spread and Fuel Contribution for Wall Material.

a. Adjust the calorimeter as specified in 3.1.b(1), (2), and (3). During cooling, replace the refractory cover with the test sample and seal the edges with asbestos cement.

b. Start the exposure fire and adjust the fuel for a rate of 17,700 Btu/min. Maintain this during the test sample exposure time of 10 minutes, while recording the flue thermocouple output to generate a time-versus-temperature curve.

c. At the end of the 10-minute exposure time, replace the test sample with the refractory cover and seal with asbestos cement.

d. Pre-plot the time-versus-temperature curve obtained in 4.1.b (curve represents fuel contributed from the exposure fire plus the sample), and insert it into the recorder to be used as the reference curve.

e. Again, following steps in 3.1.b(1), (2), and (3), adjust and maintain the exposure fire to 17,700 Btu/min.

f. Add auxiliary fuel to the evaluation burners to duplicate the time-versus-temperature curve from the test panel. Repeat this procedure, as required until the curve from the test panel is duplicated. Record the flow rates and durations of the auxiliary fuel throughout the test.

### 4.2 Flame Spread and Fuel Contribution for Composite Roof Structures.

This procedure is similar to 4.1, except that the exposure fire is adjusted for a rate of 26,500 Btu/min, and the exposure time is 30 minutes.

### 4.3 Susceptibility to Heat Damage.

a. Prepare the test sample in accordance with 3.2. Place the sample, steel side down on top of the test oven.

b. Place a metal frame on top of the test sample and secure this assembly to the top of the test oven with four "C" clamps.

c. Expose the underside of the sample to the following rising temperature conditions:

| <u>Time, minutes</u> | <u>Temperature</u> |           |
|----------------------|--------------------|-----------|
|                      | <u>°C.</u>         | <u>°F</u> |
| 0                    | Ambient            |           |
| 5                    | 218                | 425       |
| 10                   | 247                | 475       |
| 15                   | 260                | 500       |
| 20                   | 260                | 500       |

d. Remove the sample at the end of the 20-minute increment.

## 5. DATA REQUIRED.

### 5.1 Flame Spread and Fuel Contribution.

a. Composition (materials, construction, etc.) and size (length, width, and thickness) of test sample (m/cm)

b. Thermocouple locations and temperature readings (°C)

c. Exposure times (minutes)

d. Exposure fire rate (Btu/min)

e. Evaluating fuel heat value (Btu)

f. Evaluating fuel flow-meter readings (Btu/min)

### 5.2 Susceptibility to Heat Damage.

a. Data specified in 5.1.a, b, and c

b. Fuel control valve position for each test temperature

c. Visual signs of decomposition, discoloration, curling, bowing, or other damage to the test sample

## 6. DATA PRESENTATION.

### 6.1 Flame Spread and Fuel Contribution..

Use the various auxiliary fuel rates from 4.1.f in conjunction with the heat value of the evaluating fuel (propane) to compute the the fuel contribution rates of the test panel by constructing a summation curve. Figure 2 shows a typical curve that represents the various fuel contribution rates, multiplied by their respective durations, accumulated throughout the evaluation test. The "chord" on the curve represents the maximum 1-minute heat release for the sample panel occurring between 7 and 8 minutes. This rate is determined as follows:

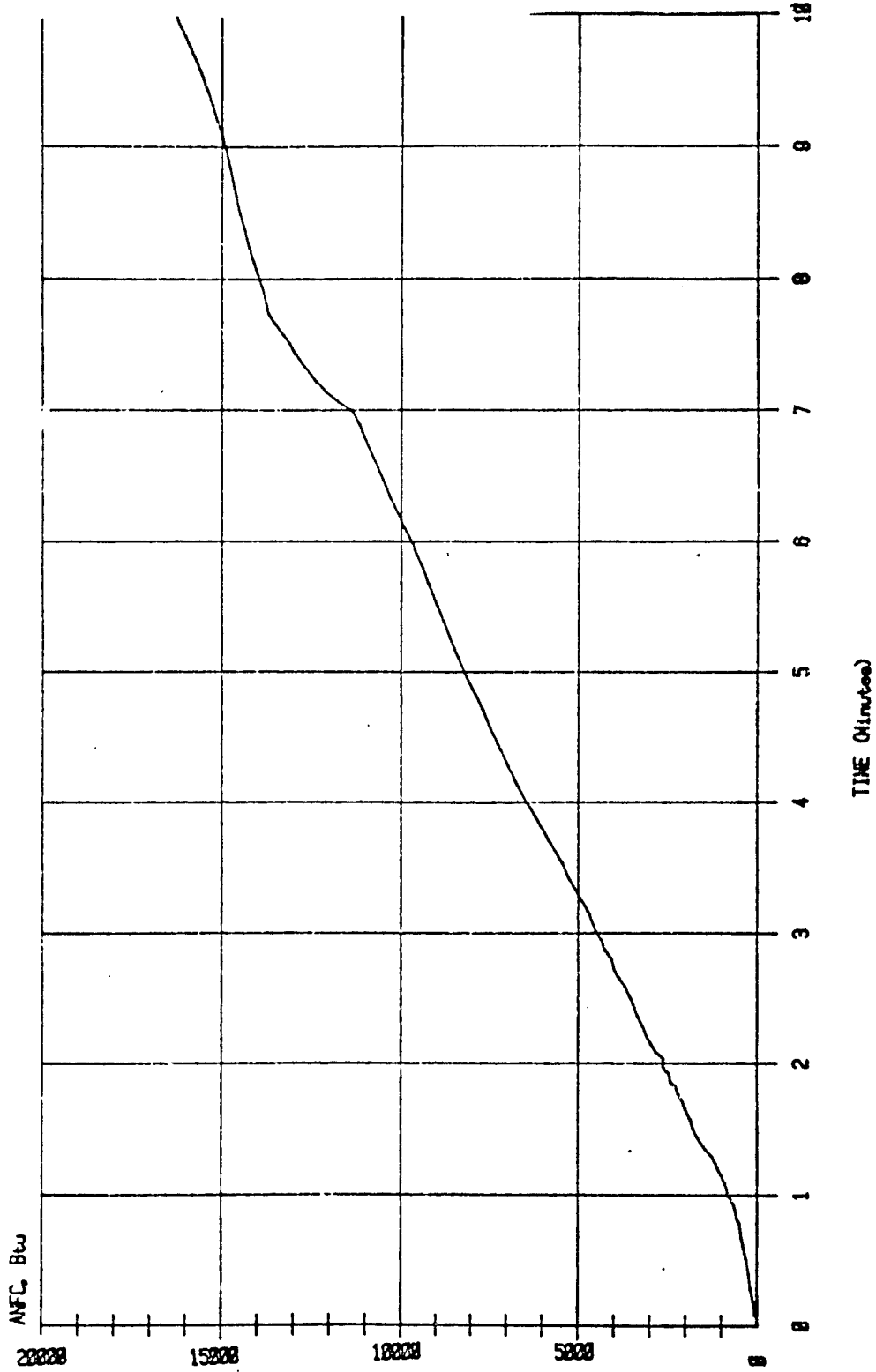

Figure 2. Typical summation curve.

Heat release = (ANFC @ 8 min - ANFC @ 7 min), in Btu

Time interval = 1 minute

Area of sample =  $1.5\text{m}^2$  ( $16\text{ ft}^2$ )

Rate of heat release,  $\text{Btu}/\text{ft}^2/\text{min}$

$$= \frac{(\text{ANFC @ 8 min} - \text{ANFC @ 7 min})}{1 \text{ min} \times (16 \text{ ft}^2)}$$

$$= \frac{(13,400 - 11,000)}{16}$$

$$= 150 \text{ Btu}/\text{ft}^2/\text{min}$$

in which ANFC = average net fuel contributed

Large-scale fire test conducted in a building 30m (100 ft) long and 6m (20 ft) wide has shown that interior finish materials with a maximum 1-minute fuel contribution of  $200 \text{ Btu}/\text{ft}^2/\text{min}$  or below, as determined in the calorimeter, do not present a rapid-spreading fire hazard. This value has therefore been selected as the 1-minute fuel-contribution rate allowable for building material to be considered suitable, in and of itself, for use without automatic sprinkler protection.

To correlate this value with currently accepted flame-spread numerology, fuel-contribution rates of  $200 \text{ Btu}/\text{ft}^2/\text{min}$  or below, are divided by a factor of 8. Thus, the maximum acceptable flame-spread index is 25.

For Figure 2, the flame-spread index is determined as follows:

$$\frac{150 \text{ Btu}/\text{ft}^2/\text{min}}{8} = 18.75 \text{ Btu}/\text{ft}^2/\text{min}$$

Rounded off to the nearest 5 = 20

The actual fuel contributed by a test sample in a given time period is an ideal basis on which to develop a fuel-contributed index. The procedure used with the calorimeter provides this information. A fuel-contributed index can be established by again using the  $200 \text{ Btu}/\text{ft}^2/\text{min}$  burning rate. During a 10-minute exposure, the maximum fuel expected to be contributed from a  $1.5\text{-sq-m}$  ( $16\text{-sq-ft}$ ) sample, based on the  $200 \text{ Btu}/\text{ft}^2/\text{min}$ , is:

$$(200 \text{ Btu}/\text{ft}^2/\text{min}) (16 \text{ ft}^2) (10 \text{ min}) = 32,000 \text{ Btu}$$

$$\text{or, } \frac{32,000 \text{ Btu}}{16 \text{ ft}^2} = 2000 \text{ Btu}/\text{ft}^2$$

Taking the  $2000 \text{ Btu}/\text{ft}^2$  as 100, on a 0-to-100 scale, the conversion factor for a fuel-contributed index is equal to 20;

$$\frac{2000 \text{ Btu}/\text{ft}^2}{100} = 20 \text{ Btu}/\text{ft}^2$$

The fuel contributed index for Figure 2 is determined as follows:

$$\frac{\text{Total Btu for 10 min}}{16 \text{ ft}^2} = \frac{16,000 \text{ Btu}}{16 \text{ ft}^2} = \frac{1000 \text{ Btu}}{20}$$

In order for the material tested to qualify for approval for use without automatic sprinkler protection, the material tested must have a flame-spread index of 25 or below, and a fuel-contributed index of 100 or below, as determined by the calorimeter testing.

The results of large-scale-fire testing have also shown that composite roof-deck assemblies with fuel-contribution rates no greater than those listed in Table 1 will not represent a rapid-spreading fire hazard potential when subjected to an interior fire. These values have therefore been selected as the maximum fuel-contribution rates allowable for composite deck assemblies to be used without automatic sprinkler protection.

TABLE 1. MAXIMUM FUEL-CONTRIBUTION RATES FOR COMPOSITE ROOF-DECK ASSEMBLIES

| <u>Time Interval (min)</u> | <u>Maximum Fuel Contribution Rates (Btu/ft<sup>2</sup>/min)</u> | <u>Maximum Allowable Deviation (Btu/ft<sup>2</sup>)</u> |
|----------------------------|---|---|
| 3                          | 385   | +25   |
| 5                          | 365   | +25   |
| 10                         | 340   | +20   |
| Avg                        | 370   | +15   |

## 6.2 Susceptibility to Heat Damage.

After the 20-minute exposure, examine the test sample, removing the face metal from the insulation. Record any signs of decomposition, discoloration, or other damage to the insulation beyond a depth of 0.32 cm (1/8 in.), and signs of curling or bowing.

Recommended changes of this publication should be forwarded to Commander, U.S. Army Test and Evaluation Command, ATTN: AMSTE-AD-M, Aberdeen Proving Ground, MD 21005-5055. Technical information can be obtained from the preparing activity: Commander, U.S. Army Combat Systems Test Activity ATTN: STECS-AD-A, Aberdeen Proving Ground, MD 21005-5059. Additional copies are available from the Defense Technical Information Center, Cameron Station, Alexandria, VA 22304-6145. This document is identified by the accession number (AD No.) printed on the first page.

APPENDIX A  
DESCRIPTION OF FLAMMABILITY TEST FACILITY  
FLAME SPREAD AND FUEL CONTRIBUTION TEST FACILITY

The test furnace represented in Figure A-1 consists of a fire box of sufficient size to fully expose a 1.4x1.5m (4.6-ft by 5-ft) horizontal test specimen; provisions for fuel and air supply; main fire exposure burners; evaluating burners; and time-temperature recording equipment.

The dimensions inside the test furnace are 1.5m (4 ft 10 in.) wide, 1m (3 ft 9 in.) deep, measured from the floor of the test furnace to the ledge of the inner walls on which the test sample is supported, and 5.3m (17 ft 6 in.) long. (Metric conversions are approximate.)

The floor of the furnace consists of an 8cm (3-in.) layer of sand and vermiculite. A baffle, situated on the floor 33cm (13 in.) from the exposure end of the furnace, consists of wire-reinforced kaloblock and measures 40cm (16 in.) high, 120cm (48 in.) long, and 6cm (2-1/2 in.) thick.

The top of the furnace is constructed of Narcocrete Castable Refractory, and contains a 1.2x1.2m (4-ft by 4-ft) opening, 1.2m from the firing end, to accommodate the test sample. A removable cover of the same material is employed during a portion of the test procedure.

Heptane fuel is supplied to the three main exposure burners at a constant rate to ensure a completely reproducible exposure controlled by a standard time-temperature curve. Figure A-2 shows the heptane fuel piping and controls.

The combustion air is supplied through a blower and is preheated to 38°C (100°F) to make the mass rate of supply independent of ambient temperature. The air flow in the supply duct is measured. An orifice installed in the blower inlet provides a flow of air for the exposure burners and sufficient access to permit a fire exposure rate of approximately 1650 Btu/ft<sup>2</sup>/min of sample.

The evaluating fuel, propane, is supplied via a flow meter at constant temperature and pressure through the arrangement shown in Figure A-3 so that any given flow-meter readings always supply the same mass rate of flow, regardless of ambient conditions.

Thermocouples are located in the 40cm (16-in.) flue on four radii at right angles to the heat flow. Temperatures are measured at four locations in each of three equal concentric areas. The readings are averaged automatically by connecting the thermocouples in series to add them, and then divided electrically before recording. Series connection rather than parallel connection is used so that failure of a thermocouple is clearly and immediately apparent.

Temperatures monitored by the flue thermocouples are recorded. These readings are used to correlate the quantity of evaluating fuel with the fuel contribution of the test panel; the exposure is the same in both aspects of the test.

Furnace temperatures in the vicinity of the test panel are also monitored by thermocouples.

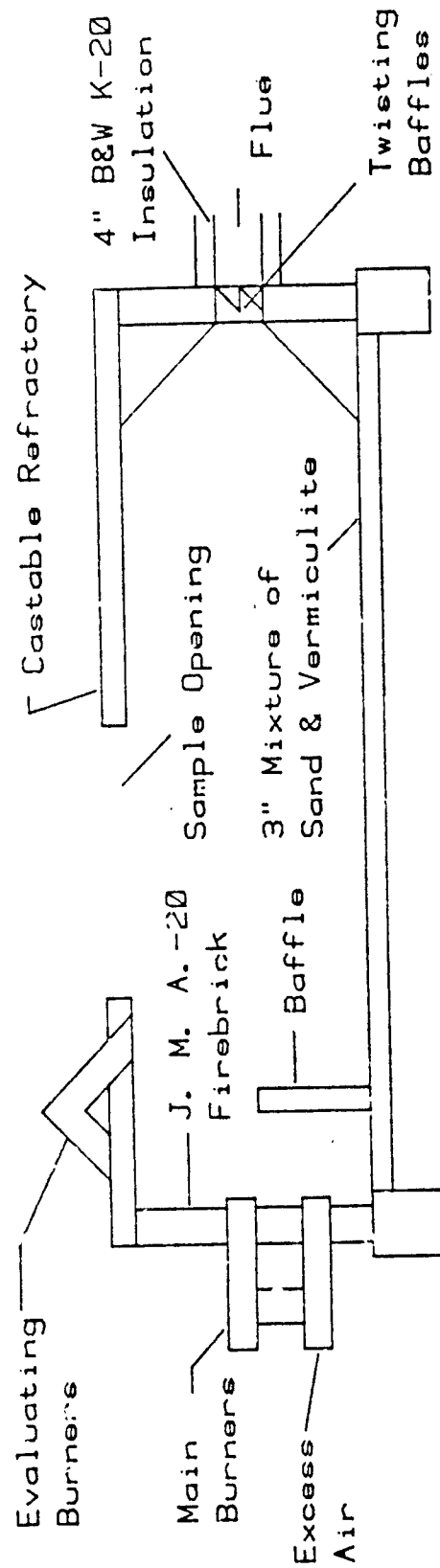

Figure A-1. Dimension and construction details of the Calorimeter.

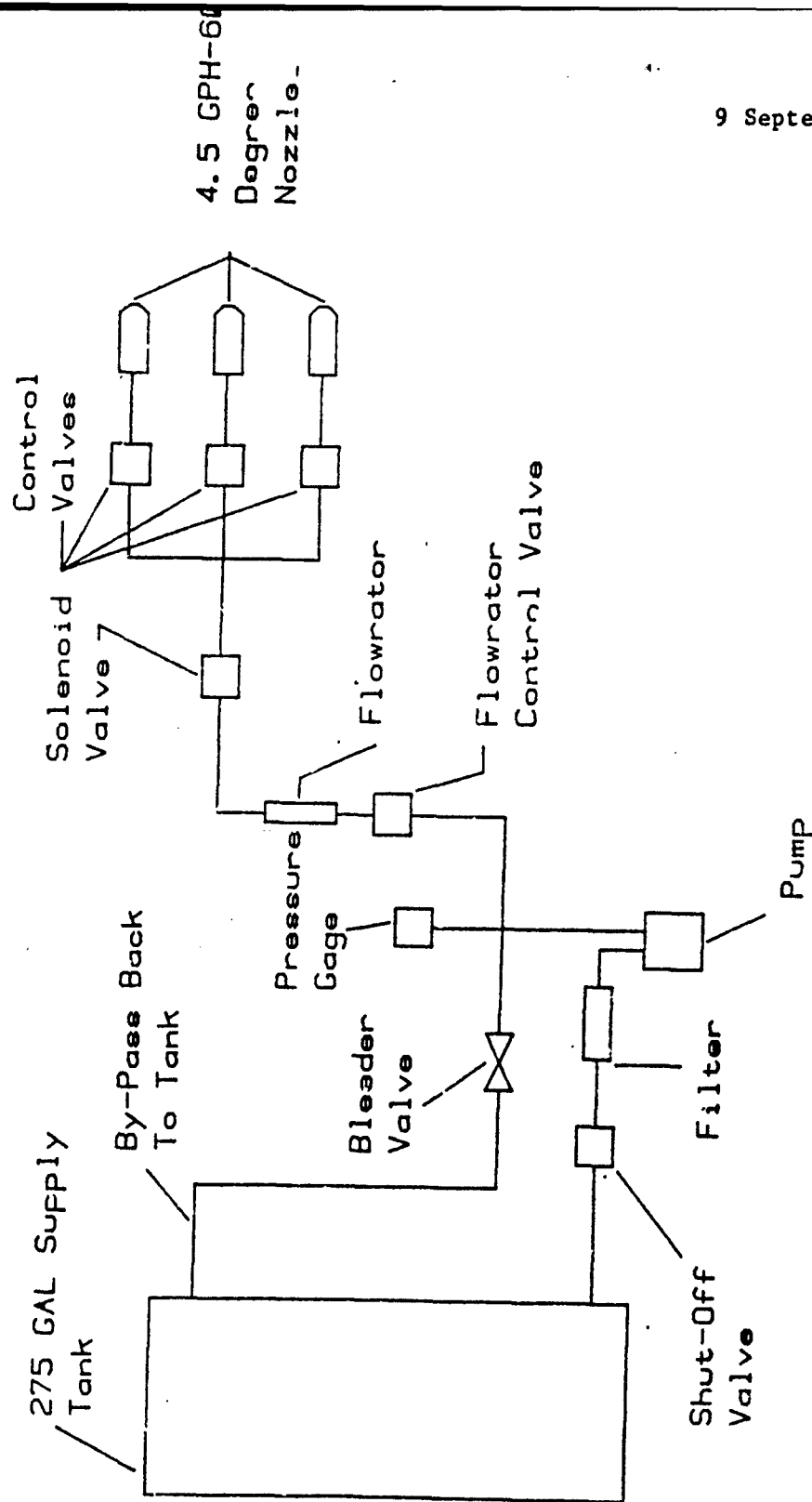

Figure A-2. Fuel piping and controls for Calorimeter.

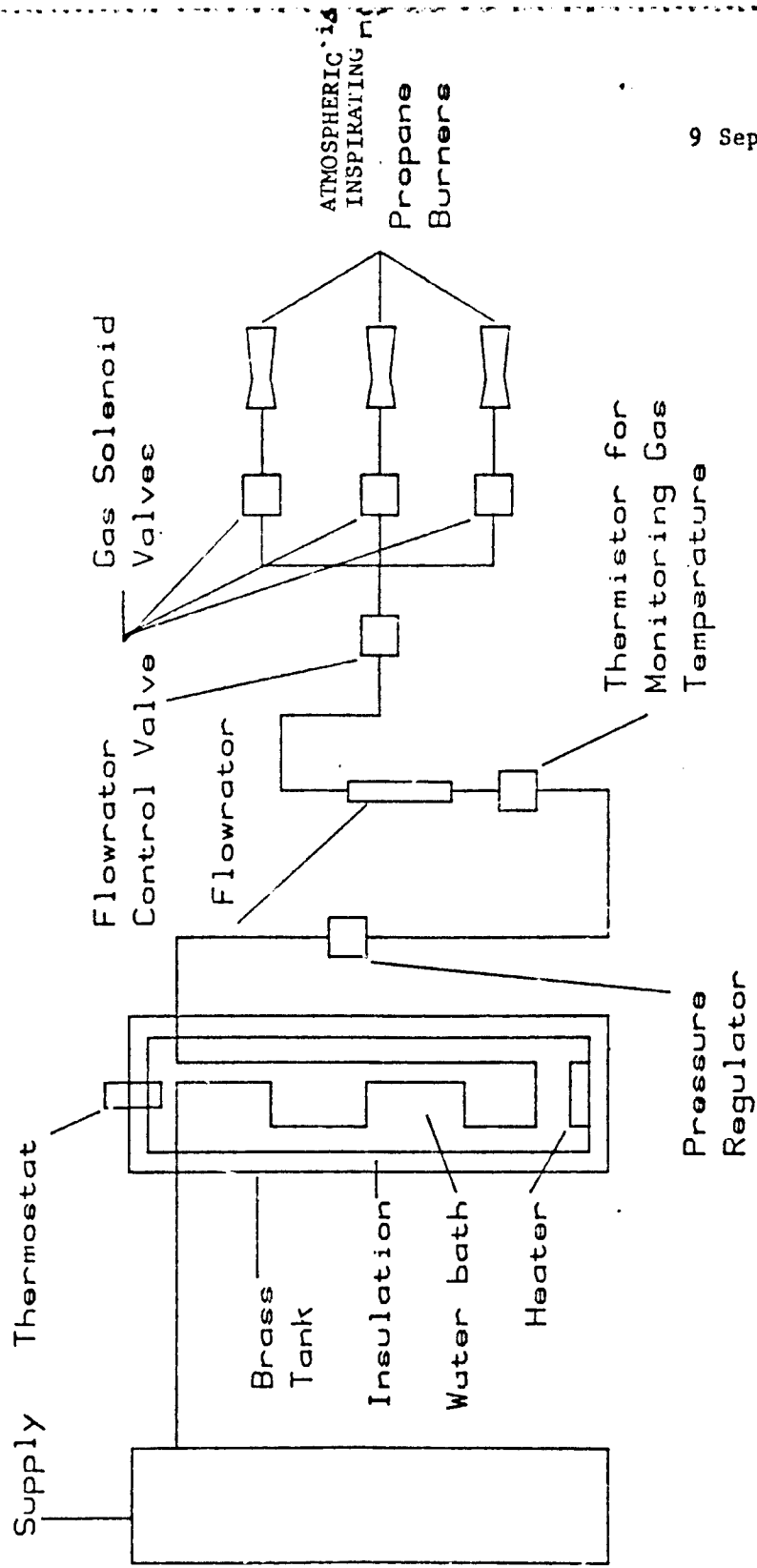

Figure A-3. Layout diagram of evaluating system.

Susceptibility-to-radiant-heat-damage test facility.

The test oven consists of a fire box of sufficient size to fully expose a 30cmx30cm (12-in. by 12-in.) horizontal test sample, provisions for fuel and air supply, exposure burner, and time-temperature recording equipment.

The walls of the oven are constructed of 30cmx30cm panels of 1.3cm- (1/2-in.)-thick asbestos board, secured at the corners with 3.8cmx6.3cm (1-1/2-in. by 2-1/2-in.) metal lumber angles. This wall assembly is supported on the metal angles, and rests 2cm (3/4 in.) off the oven floor which is composed of 2cm-thick asbestos board. This arrangement permits entry of a natural draft air supply.

The horizontal test sample forms the top of the oven. Two 40cm- (16-in.)-long metal lumber angles are bolted along the top sides of two opposite walls of the oven to support the test sample and to allow it to be clamped in place.

The firing unit consists of an eight-armed 14cm- (5-1/2-in.)-diameter gas burner with a pilot inserted into the center hole. This unit is centrally located on the floor of the oven. Propane gas at 5 psi is fed through a regulator into the burner. Gas flow is controlled by manual operation of a valve.

A 15cm- (6-in.)-diameter by 14-mil-thick circular steel baffle is supported over the burner to prevent flame impingement on the sample. The distance from the floor of the oven to the baffle is 11cm (4-1/2 in.).

APPENDIX B  
REFERENCES

1. Methodology Investigation, Final Report No. APG-MT-5680, Development of a Flammability Test for Military Shelters, J.E. Werner and G.A. Denn, August 1982.
2. TOP 10-2-175, Tents and Shelters, 19 March 1984.
3. MIL-STD 907A, Engineering and Design Criteria for Shelters, Expandable and Nonexpandable, 30 January 1984.

**END**

**FILMED**

**10-85**

**DTIC**