

MICROCOPY RESOLUTION TEST CHART
NATIONAL BUREAU OF STANDARDS-1963-A

INSTRUCTION REPORT HL-85-1

USER'S MANUAL FOR THE GENERALIZED
COMPUTER PROGRAM SYSTEM

OPEN-CHANNEL FLOW AND SEDIMENTATION
TABS-2
Main Text

by

William A. Thomas, William H. McAnally, Jr.

Hydraulics Laboratory

DEPARTMENT OF THE ARMY
Waterways Experiment Station, Corps of Engineers
PO Box 631, Vicksburg, Mississippi 39180-0631



July 1985
Final Report

Approved For Public Release; Distribution Unlimited

DTIC
ELECTE
SEP 17 1985
S D

Prepared for

DEPARTMENT OF THE ARMY
US Army Corps of Engineers
Washington, DC 20314-1000

85 09 13 014



US Army Corps
of Engineers

AD-A159 249



DTIC FILE COPY

HYDRAULICS
LABORATORY

Unclassified

SECURITY CLASSIFICATION OF THIS PAGE (When Data Entered)

REPORT DOCUMENTATION PAGE		READ INSTRUCTIONS BEFORE COMPLETING FORM
1. REPORT NUMBER Instruction Report HL-85-1	2. GOVT ACCESSION NO. AD A159 249	3. RECIPIENT'S CATALOG NUMBER
4. TITLE (and Subtitle) USER'S MANUAL FOR THE GENERALIZED COMPUTER PROGRAM SYSTEM: OPEN-CHANNEL FLOW AND SEDIMENTATION, TABS-2; Main Text	5. TYPE OF REPORT & PERIOD COVERED Final report	
	6. PERFORMING ORG. REPORT NUMBER	
7. AUTHOR(s) William A. Thomas William H. McAnally, Jr.	8. CONTRACT OR GRANT NUMBER(s)	
9. PERFORMING ORGANIZATION NAME AND ADDRESS US Army Engineer Waterways Experiment Station Hydraulics Laboratory PO Box 631, Vicksburg, Mississippi 39180-0631	10. PROGRAM ELEMENT, PROJECT, TASK AREA & WORK UNIT NUMBERS	
11. CONTROLLING OFFICE NAME AND ADDRESS DEPARTMENT OF THE ARMY US Army Corps of Engineers Washington, DC 20314-1000	12. REPORT DATE July 1985	
	13. NUMBER OF PAGES 35	
14. MONITORING AGENCY NAME & ADDRESS (if different from Controlling Office)	15. SECURITY CLASS. (of this report) Unclassified	
	15a. DECLASSIFICATION/DOWNGRADING SCHEDULE	
16. DISTRIBUTION STATEMENT (of this Report) Approved for public release; distribution unlimited.		
17. DISTRIBUTION STATEMENT (of the abstract entered in Block 20, if different from Report)		
18. SUPPLEMENTARY NOTES Available from National Technical Information Service, 5285 Port Royal Road, Springfield, Virginia 22161. This report is published in two forms--bound without appendices and looseleaf with Appendices A-0. The loose-leaf form is distributed to users of the system, who will be provided updates as they are issued.		
19. KEY WORDS (Continue on reverse side if necessary and identify by block number) Computer programs--Handbooks, manuals, etc. (LC) Hydraulics--Computer programs (LC) Sediment transport--Computer programs (LC) TABS-2 (Computer programs) (WES)		
20. ABSTRACT (Continue on reverse side if necessary and identify by block number) TABS-2 is a generalized numerical modeling system for open-channel flows, sedimentation, and constituent transport. It consists of more than 40 computer programs to perform modeling and related tasks. The major modeling components--RMA-2V, STUDH, and RMA-4--calculate two-dimensional, depth-averaged flows, sedimentation, and dispersive transport, respectively. The other programs in the system perform digitizing, mesh generation, data management, graphical display, output analysis, and model interfacing tasks. Utilities (Continued)		

20. ABSTRACT (Continued).

include file management and automatic generation of computer job control instructions.

TABS-2 has been applied to a variety of waterways, including rivers, estuaries, bays, and marshes. It is designed for use by engineers and scientists who may not have a rigorous computer background. Use of the various components is described in Appendices A-0.

The bound version of the report does not include the appendices. A looseleaf form with Appendices A-0 is distributed to system users.

Accession For	
NTIS GRA&I	<input checked="" type="checkbox"/>
DTIC TAB	<input type="checkbox"/>
Unannounced	<input type="checkbox"/>
Justification	<input type="checkbox"/>
Distribution/	
Availability Codes	
Dist	Avail and/or Special
A-1	



PREFACE

The TABS-2 system described herein was developed over the period 1972-1984. This User's Manual was prepared at the US Army Engineer Waterways Experiment Station (WES) with funding provided by the Office, Chief of Engineers, US Army, under the Improvement of Operations and Maintenance Techniques (IOMT) research program. Funding for the various components of the system came from several sources within the Corps of Engineers, but the largest portion of those funds came from the IOMT Program. Technical monitors of the IOMT program were Messrs. J. L. Gottesman and C. W. Hummer, Jr.

The principal sources for the programs and procedures are the staff of the WES Hydraulics Laboratory; Resource Management Associates, Lafayette, Calif.; University of California, Davis; US Army Corps of Engineers Hydrologic Engineering Center; and the WES Environmental Laboratory. Sources of individual programs in the TABS-2 system are given in this manual where the programs are described.

Personnel of the WES Hydraulics Laboratory performed their portion of system development under direction of Messrs. H. B. Simmons and F. A. Herrmann, Jr., former and present Chiefs of the Hydraulics Laboratory, respectively; M. B. Boyd, Chief of the Hydraulic Analysis Division; R. A. Sager, Chief of the Estuaries Division; G. M. Fisackerly, Chief of the Harbor Entrance Branch; R. A. Boland, Chief of the Hydrodynamics Branch; and E. C. McNair, Chief of the Sedimentation Branch. Messrs. W. A. Thomas and W. H. McAnally supervised development of the programs and system and prepared this report. Authors of the appendices, published separately in looseleaf form, are cited in each appendix.

Hydraulics Laboratory personnel making major contributions to development of the TABS-2 system were S. A. Adamec, R. F. Athow, D. P. Bach, R. C. Berger, B. Brown, Jr., C. J. Coleman, R. R. Copeland, B. Park-Donnell, J. D. Ethridge, Jr., M. A. Granat, S. S. Grogan, R. E. Heath, S. B. Heltzel, J. V. Letter, Jr., R. D. Schneider, T. M. Smith, D. M. Stewart, J. P. Stewart, A. M. Teeter, and M. J. Trawle. Dr. V. E. LaGarde, WES Environmental Laboratory, performed initial development of many DMS-A programs. Messrs. A. Melidor, St. Louis District, and J. Hines, Vicksburg District, performed field trials of many of the programs. Mr. Hines initiated development of the Greenville Reach mesh.

Commanders and Directors of WES during the preparation of this manual were COL Nelson P. Conover, CE, COL Tilford C. Creel, CE, and COL Robert C. Lee, CE; Technical Director was Mr. F. R. Brown. Commander at time of publication was COL Allen F. Grum, USA, and Technical Director was Dr. Robert W. Whalin.

CONTENTS

	Page
PREFACE	1
PART I: INTRODUCTION	6
Purpose	6
Description	6
Scope	9
A Comparison of 1-D and 2-D Numerical Modeling	10
Origin of the System	11
Applications	13
Limitations	13
Future Improvements	14
Related Systems	14
Organization of the Manual	14
PART II: SYSTEM DESIGN	16
Capability of the System	16
Components of the System	17
Files	17
Structure of the Geometry Data Base	18
Data Management	19
Job Control Language (PROCLV)	19
PART III: HOW TO USE THE SYSTEM	20
Access	20
Summary of Steps	20
Study Management	22
PART IV: EXAMPLE PROBLEM	23
PART V: INDEX OF PROGRAMS	30
TABLES 1-3	
APPENDICES*	
A: BIBLIOGRAPHY	A1
B: GLOSSARY	B1
C: EXAMPLE PROBLEM	C1
D: NETWORK GENERATION	D1
E: DIGITIZING INSTRUCTIONS	E1
F: RMA-2V USER INSTRUCTIONS	F1
G: STUDH USER INSTRUCTIONS	G1
H: RMA-4 USER INSTRUCTIONS	H1
I: GRAPHICS DISPLAYS	I1
J: OUTPUT ANALYSIS	J1
K: FIELD DATA NEEDS	K1
L: DATA MANAGEMENT SYSTEM A	L1
M: INTERFACES	M1
N: FILES AND FMS	N1
O: PROCLV - PROCEDURE FILES FOR JOB CONTROL	O1

*Published separately in looseleaf form.

INDEX BY PROGRAM NAME

TABS-2 SYSTEM MANUAL

PROGRAMS

APPENDIX

I. PREPROCESSOR PROGRAMS

A. DIGITIZER PROGRAMS

1.	MESH1	L
2.	MESH2	L
3.	MESH3	L
4.	REFMT	L
5.	DMSDIG	L

B. NETWORK GENERATION PROGRAMS

1.	AUTOMSH	D
2.	EDGRG	D
3.	GFGEN	D
4.	CONFEG	D
5.	FNDNODE	D

C. SPATIAL DATA MANIPULATION PROGRAMS

(see POST PROCESSOR PROGRAMS)

II. MAIN PROGRAMS

A.	TWO-DIMENSIONAL FLOW MODEL (RMA-2V)	F
B.	SEDIMENT TRANSPORT IN UNSTEADY, TWO-DIMENSIONAL FLOW, HORIZONTAL PLANE (STUDH)		G
C.	TWO-DIMENSIONAL CONSTITUENT TRANSPORT (RMA4)	H

III. POST PROCESSOR PROGRAMS

A. PLOT PROGRAMS

1.	ACE	J
2.	CONTOUR	I
3.	DIRECT	I
4.	DGPLT	L
5.	DROGUEPLT	I
6.	POSTHYD	J
7.	SEDGRAPH	I
8.	VPLLOT	I
9.	DUMPER2	L
10.	WDGPlot	I

INDEX (continued)

APPENDIX

B. OUTPUT ANALYSIS PROGRAMS

1. ACE	J
2. POSTHYD	J
3. POSTSED	J

C. SPATIAL DATA MANIPULATION PROGRAMS

1. BATHVOL	L
2. ELEVGRD	L
3. FACGRID	L
4. GRDSUB	L
5. RETPNT	L

IV. DATA AND FILES MANAGEMENT

A. WESDMS	L
---------------------	---

V. INTERFACE PROGRAMS

A. DUMB INTERFACES

1. ENGMET	M
2. TRANSA	L
3. BIN2FOR	M
4. FOR2BIN	M
5. GET	M

B. SMART INTERFACES

1. ELEVGRD	L
2. GRDSUB	L
3. JOBSTREAM	M

VI. FILES AND FILE MANAGEMENT N

VII. JOB CONTROL LANGUAGE FOR EXECUTION, PROCLV O

CONVERSION FACTORS, NON-SI TO SI (METRIC)
UNITS OF MEASUREMENT

Non-SI units of measurement used in this report can be converted to SI (metric) units as follows:

<u>Multiply</u>	<u>By</u>	<u>To Obtain</u>
cubic feet per second	0.02831685	cubic metres per second
feet	0.3048	metres
feet per second	0.3048	metres per second
inches	25.4	millimetres

USER'S MANUAL FOR THE GENERALIZED
COMPUTER PROGRAM SYSTEM
OPEN-CHANNEL FLOW AND SEDIMENTATION

TABS-2

Main Text

PART I: INTRODUCTION

Purpose

1. This report describes use of the TABS-2 system for numerical modeling. The purpose of the TABS-2 system is to provide a complete set of generalized computer programs for two-dimensional (2-D) numerical modeling of open-channel flow, transport processes, and sedimentation. These processes are modeled to help solve hydraulic engineering and environmental problems in waterways. The system is designed to be used by engineers and scientists who need not be computer experts.

Description

2. TABS-2 is a collection of generalized computer programs and utility codes integrated into a numerical modeling system for studying 2-D hydraulics, transport, and sedimentation problems in rivers, reservoirs, bays, and estuaries. A schematic representation of the system is shown in Figure 1.

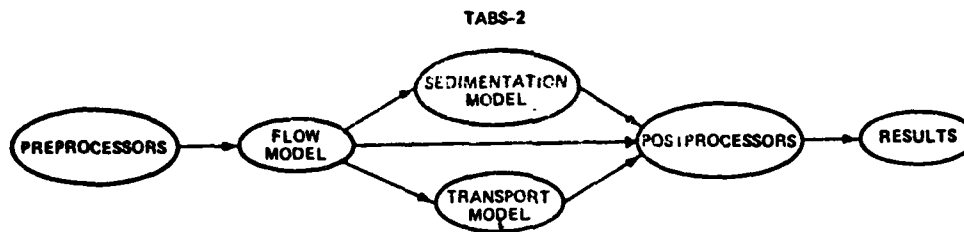

Figure 1. TABS-2 schematic

It can be used either as a stand-alone solution technique or as a step in the hybrid modeling approach. The basic concept is to calculate water-surface elevations, current patterns, dispersive transport, sediment erosion, transport and deposition, resulting bed-surface elevations, and feedback to hydraulics. Existing and proposed geometry can be analyzed to determine the impact of project designs on flows, sedimentation, and salinity. The calculated velocity pattern around structures and islands is especially useful.

3. The three basic components of the system are:

- a. "Two-Dimensional Model for Open-Channel Flows," RMA-2V.
- b. "Sediment Transport in Unsteady Two-Dimensional Flows, Horizontal Plane," STUDH.
- c. "Two-Dimensional Model for Water Quality," RMA-4.

4. RMA-2V is a finite element solution of the Reynolds form of the Navier-Stokes equations for turbulent flows. Friction is calculated with Manning's equation and eddy viscosity coefficients are used to define turbulence characteristics. A velocity form of the basic equation is used with side boundaries treated as either slip (parallel flow) or static (zero flow). The model automatically recognizes dry elements and corrects the mesh accordingly. Boundary conditions may be water-surface elevations, velocities, or discharges and may occur inside the mesh as well as along the edges.

5. The sedimentation model, STUDH, solves the convection-diffusion equation with bed source terms. These terms are structured for either sand or cohesive sediments. The Ackers-White procedure is used to calculate a sediment transport potential for the sands from which the actual transport is calculated based on availability. Clay erosion is based on work by Partheniades and the deposition of clay utilizes Krone's equations. Deposited material forms layers, as shown in Figure 2, and bookkeeping within the STUDH code allows up to 10 layers at each node for maintaining separate material types, deposit thickness, and age. The code uses the same mesh as RMA-2V.

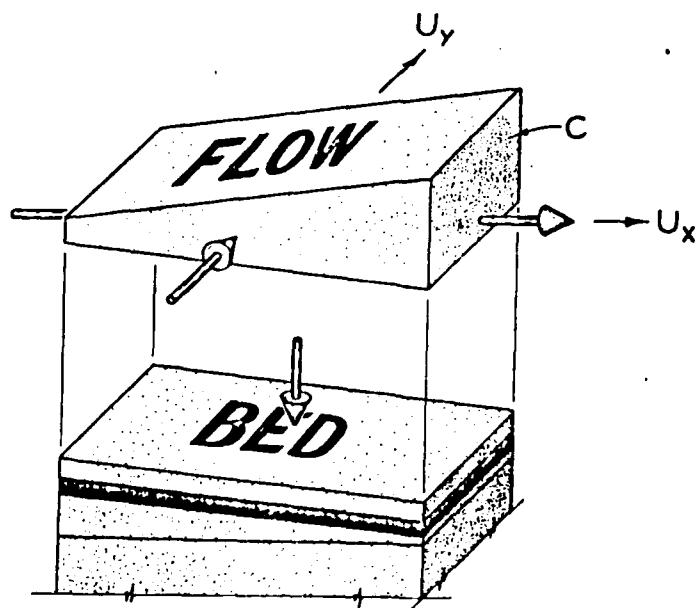

Figure 2. Bed layering in STUDH

6. Transport calculations with RMA-4 are made using a form of the convection-diffusion equation that has general source-sink terms. Up to seven conservative substances or substances requiring a decay term can be routed. The code uses the same mesh as RMA-2V.

7. Each of these generalized computer codes (RMA-2V, STUDH, and RMA-4) can be used as a stand-alone program. To facilitate the preparation of input data and to aid in analyzing results, a family of utility programs was developed for the following tasks:

- a. DIGITIZING
- b. MESH GENERATION
- c. SPATIAL DATA MANAGEMENT
- d. GRAPHICAL OUTPUT
- e. OUTPUT ANALYSIS
- f. FILE MANAGEMENT
- g. INTERFACES
- h. AUTOMATIC JOB CONTROL LANGUAGE

The codes for accomplishing these tasks are shown in PART V of this manual.

8. One can assume the nature of the computations by their stated purpose; but to better illustrate the roll these utility codes play in TABS-2, an analogy between the steps in a physical modeling study and a numerical modeling study of the same problem is useful.

9. Both fixed- and mobile-boundary hydraulic problems are classified as "boundary value" problems. The project area has to be defined and a boundary drawn completely around it. The space within the boundary becomes the study area and hydraulic processes in the area depend on what occurs at the boundaries. In a physical model study, the geometry of that space is molded to create a scale model of the prototype. In a numerical model study, hydrographic maps are DIGITIZED into (x,y,z)-coordinates to create a digital map of that space. Next, in a physical model study, the model is flooded, the tailwater elevation is set at the downstream boundary, the flow is set at the upstream boundary, and the interior of the model automatically responds to those BOUNDARY CONDITIONS. In a numerical model, the concept is the same, but the procedure for executing the numerical model is somewhat more abstract. First, the digital map will have more data points than can be used in today's computers, so points are consolidated into computation nodes. These nodes are then linked together, using quadrilateral or triangular shapes, into a computation space. These shapes, called elements, form a mesh and the

process of developing the mesh is called MESH GENERATION. The step similar to flooding the physical model, called INITIAL CONDITIONS in the numerical model study, requires that an initial depth of water be prescribed at each node in the mesh. The tailwater and headwater conditions are prescribed (i.e., the BOUNDARY CONDITIONS) and the model is run, at which time the computer solves the basic equations at each node and produces the internal response to the BOUNDARY CONDITIONS. For this reason, it is called a boundary value problem.

10. Whereas the response of the physical model can be easily viewed, the response of the numerical model is simply spatial data sets of numbers. They are called spatial because the computer program produces a set of numbers at each node within the model boundary (i.e., over the model space) and a typical mesh will have several thousand nodes. The analysis of numerical model behavior requires the evaluation of these numbers as well as their gradients in the (x,y) plane. (For example, a water-surface profile becomes a water-surface plane because there is a calculated water-surface elevation at each node.) The handling, storing, and comparing of large sets of spatial data are extremely important parts of the TABS-2 system, as shown by references to SPATIAL DATA MANAGEMENT, GRAPHICAL OUTPUT, and OUTPUT ANALYSIS utilities. Their purpose is to aid in analyzing and displaying results of the numerical model study.

11. Each time a new set of boundary conditions is prescribed or a new design change in geometry is proposed, another spatial data set is produced. The task of storing, retrieving, and using these data sets requires careful indexing and labeling. A FILE MANAGER was developed to handle that task.

12. Occasionally, spatial data sets must be manipulated before being used by another program. Special INTERFACE utilities were prepared for those occasions.

13. Finally, an AUTOMATIC JOB CONTROL LANGUAGE (JCL) procedure file was developed for executing the TABS-2 programs. It allows input and output file names to be assigned at execution time and keeps the details of the JCL transparent to the user. This procedure file, called PROCLV, is complete with a "HELP" command that describes the input data.

Scope

14. This user's manual provides instructions for coding data for the TABS-2 system. Sufficient theory is provided to guide in the selection of coefficients and in decisions regarding applicability. A major factor in this class of computer programs is problem size, and this manual shows how to change array dimensions as needed to fit the programs to the size of problems being analyzed. Although modeling is very much an art, some general

PART IV: EXAMPLE PROBLEM

72. Appendix C contains an example problem that illustrates the steps in applying TABS-2. The following example uses the results of an application on the Mississippi River near Greenville, Mississippi, to briefly illustrate model performance.

73. The Greenville Reach of the Mississippi River starts at the Greenville Bridge, river mile 531.33, and extends about 15 miles upstream (Figure 3). The Potamology Research Section, US Army Engineers Division, Lower Mississippi Valley, developed the computational network, provided hydrographic survey data, flow velocities, float measurements, and water-surface elevations for testing the performance of the RMA-2V code for hydraulic calculations. Results of that application are presented below.

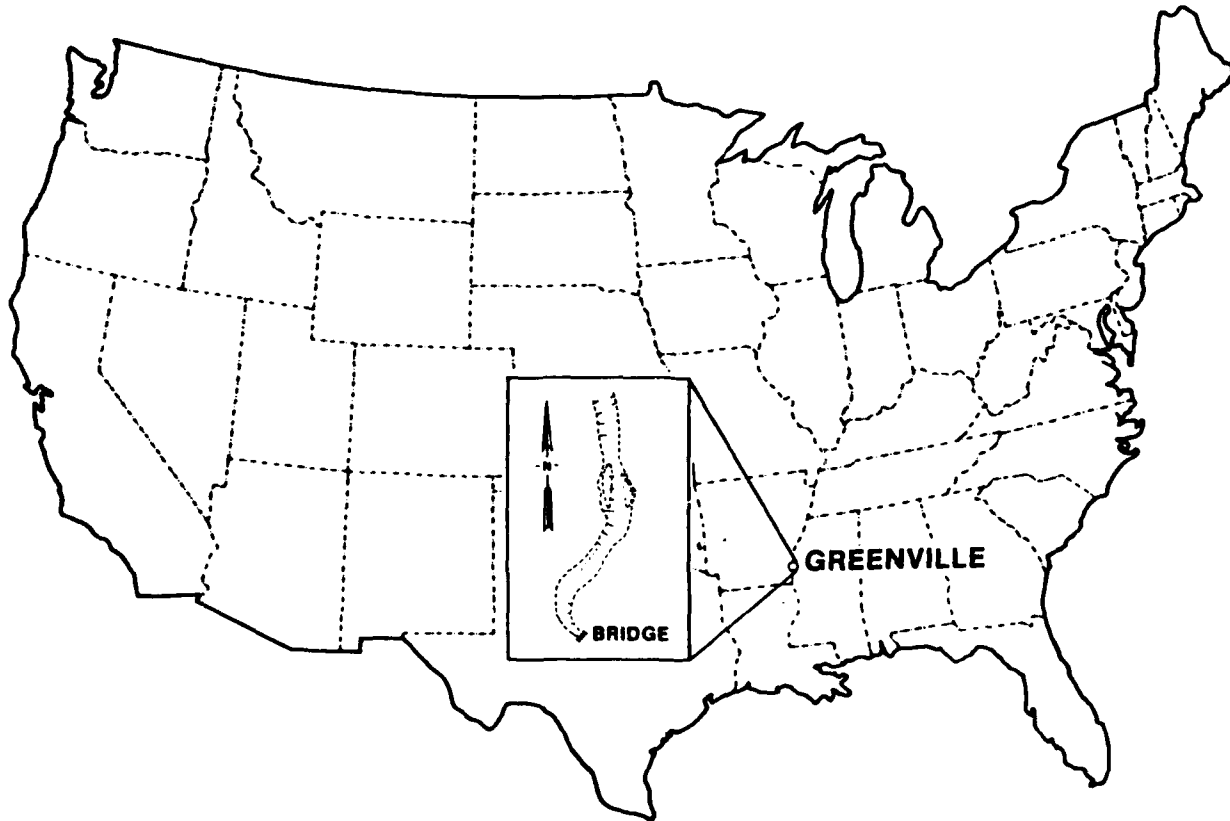

Figure 3. Vicinity map, Greenville reach, Mississippi River

and proceed toward the more complex. Attempt to define a case in which a steady-flow water discharge and a steady-state sediment concentration at the boundary can be run with negligible change in the bed elevations. When that case runs satisfactorily, begin time-dependent boundary conditions or flow field runs. Always limit changes to one parameter at a time. Details for running STUDH are presented in Appendix G.

Step 8. CYCLE BETWEEN STUDH AND RMA-2V

69. The STUDH program will produce a new geometry file that can be cycled back through RMA-2V as needed. A general rule of thumb is to allow the bed surface to change by a foot or 10 percent of the depth before rerunning RMA-2V, but each study must be prepared to modify that general rule if results so indicate.

Study Management

70. Key words appropriate for 2-D numerical modeling studies are plan-monitor-evaluate. An inadequate plan of study will often cause the study time to increase, thereby increasing manpower and computer costs. Inadequate monitoring of ADP usage can allow the entire annual budget for ADP to be spent early in the project. Inadequate evaluation of study results will lead to misinterpretation. This type of study will produce many more numbers than the engineer is historically accustomed to, so the procedures for evaluating results must be carefully thought out.

71. The review of results produced by 2-D numerical models should always include volumes or total masses as well as the rates and distributions which are calculated and printed out by the programs. Always ascertain that the geometry, as defined by connecting the (x,y,z) coordinates of the finite element network with a series of planes, closely approximates the prototype, that n-values are assigned in accordance with standard procedures for estimating hydraulic roughness, and that the diffusion coefficients are reasonable. Although mentioned last, the diffusion coefficients issue is by no means of least importance. Head loss at contractions and eddy formations are strongly controlled by the diffusion coefficients. Often, a sensitivity study is the only method for testing the role the diffusion coefficients play in the results of a particular study.

begins by defining the model limits. They should extend several river widths on either side of the study area so the parameters prescribed as boundary conditions will be outside the influence of changes occurring in the study area. The next task is to sketch the desired mesh on an overlay and establish regions having similar hydraulic properties. Then, digitize the boundary around each region for input into the mesh generator. The output from the mesh generator is combined with card image run control data, without bed elevations, and input into GFCEN where the curved boundaries of the mesh are calculated and elements are re-ordered for more efficient computations. The output file from GFCEN is the network needed by RMA-2V except bed elevations are usually not yet coded. Bed elevations can be input from the beginning, but it is not recommended. Normally, run the RMA-2V "leak" test at this point by assuming the bed is at elevation "zero" or some other appropriate, constant value. Running a flat-bottom leak test first will shorten total study time. The final step in network generation is to determine the bed elevation at each corner node in the mesh.

Step 4. RUN LEAK TEST IN RMA-2V

65. The purpose of the leak test is to check the mesh, boundaries, and boundary condition types for leaks. The performance criterion is continuity of water. The approach is to establish a condition of a horizontal pool and an inflow velocity, or discharge, equal to zero. If water leaks out of the network, either the network or boundary conditions contain errors. A second leak test with actual bottom elevations is performed as a final check on network adequacy. Details are given in the RMA-2V user instructions, Appendix F.

Step 5. ESTABLISH THE INITIAL CONDITIONS

66. Initial conditions refer to the initial depths of water and velocity at every node. The first choice is always a constant elevation and zero velocity because that is easiest to code. If computations converge that approach is successful, but if computations fail to converge use the HOTSTART procedure explained in the RMA-2V documentation.

Step 6. RUN TESTS IN RMA-2V

67. Testing always starts with verification to field or other appropriate data. After this point, the desired tests are run. The most difficult task in running tests is maintaining adequate documentation of what is being tested, the results, and how this test differs from those before and after it. Careful note-keeping is strongly recommended and some techniques are described in the appendices, particularly Appendix N.

Step 7. RUN TESTS IN STUDH

68. There is no leak test for STUDH, but it is important to establish a sequence of tests that start with a simple condition

PART III: HOW TO USE THE SYSTEM

Access

58. TABS-2 is available at the primary computer site for the Corps of Engineers. Interested users should notify the Chief of the Hydraulic Analysis Division of the Hydraulics Laboratory at WES.

59. The system is maintained on the Corps contract computing site, which is presently CYBERNET. Library versions of the programs and procedure files are stored on the TABS-2 user number. Approved users are given read and execute permissions for the system programs.

60. PROCLV, the procedure file used to generate job control language and submit batch jobs, is transferred to each user's number and installed there. The installation procedure customizes PROCLV to the user's needs.

Summary of Steps

61. This section summarizes the steps in applying TABS-2. Details for step 3 and following steps are presented in the appendices of this report where each code is described. A more detailed list of steps is given in Table 2. The following steps assume that access to the system has been established.

Step 1. STATEMENT OF PURPOSE AND END PRODUCT

62. For the most part, numerical modeling answers questions posed by the modeler rather than simulates the behavior of the proposed prototype project. Rarely will it "surprise" the modeler with unexpected problems. Consequently, the questions to ask of the model must be formulated before the study gets under way. Other questions usually surface as the study progresses, but the desired end product of the study needs to be specified at the beginning.

Step 2. FIELD DATA ACQUISITION

63. This is self-explanatory except for the question "What data are needed?" In general, the same prototype data are required for a numerical model study as are required for a physical model study: geometry, roughness, structures and other man-made changes, hydrology, sedimentation, hydraulic character, development plans, operational policies, and performance criteria. APPENDIX K discusses field data collection.

Step 3. MESH LAYOUT AND DESIGN

64. Mesh layout, entitled Network Generation in Appendix D,

flow model's file structure in Appendix N with the HEC-2 manual.

Data Management

54. Data management is essential to a well-executed numerical model study. The TABS-2 data management system (DMS) is quite specialized for numerical modeling studies, but it also contains some parts that are applicable to a wide range of engineering studies.

55. Data management in TABS-2 is accomplished in several ways at the user's choice. The WES Data Management System A is used to process, store, and manipulate spatially distributed data.

56. The TABS-2 DMS consists of:

- a. Manual data handling procedures.
- b. Gridding and grid transformation programs.
- c. Programs to perform data manipulation and display.
- d. Files management.

Items a-c above are described in Appendix L: Data Management System A. Item d is described in Appendix N: Files and FMS and in Appendix O: PROCLV.

Job Control Language (PROCLV)

57. The TABS-2 system includes a procedure file that is invoked from an interactive terminal and automatically writes job control language (JCL) to cause any program in the system to be executed, assigns input files, saves output files, and routes results to the appropriate device. Only one line of information is needed. Details for using this procedure are presented in Appendix O.

RMA-2V computer program for hydraulic calculations, the STUDH computer program for sediment transport calculations, and the RMA-4 computer program for dispersive transport calculations. The WESDMS Subsystem files are used for spatial data management. Consequently, the digitizer, digital mapping, adding and subtracting digital maps from one another to get shoaling or scour volumes, etc., use the WESDMS Subsystem files. The vector and contour plotting programs can read files from either subsystem. Interface programs are available for transferring data from one of these file subsystems to the other. These programs are described in Appendix M: Interfaces and in Appendix L: Data Management System A. The file structures are described in Appendix N: Files and FMS.

48. The finite element computer codes, which make up the primary computation programs in TABS-2, are linked together by files. For example, the geometry of the study area is digitized and processed during the finite element network generation task. The resulting file is saved for use by the RMA-2V flow model, by the STUDH sediment transport model, by the RMA-4 transport model, and by various utility programs in the systems. The geometric data file structure is described in Appendix N: Files and FMS.

49. The flow model produces a file of hydraulic parameters that is read by the sediment transport model, by the salinity transport model, and by the utility programs. The file structure is described in Appendix N under Flow Model Files.

50. The sediment transport model produces a file of concentrations and bed elevation changes that can be read by the sediment utilities. In addition, it produces an updated finite element network file that has the new bed elevations calculated by the sediment transport model. The new file can be read by the flow model. These files are described in Appendix N under Sediment Model Files.

51. The Transport Model produces a file of concentrations that can be read by the contour program. This file is described in Appendix N under the section Transport Model Files.

52. Numerous other files can be produced. These are described in Appendix N also.

Structure of the Geometry Data Base

53. The computer program, "Water-Surface Profiles" (HEC-2), produced by the Hydrologic Engineering Center, has set a standard for geometry data because of its widespread use both in and out of the Corps of Engineers. However, that data structure requires only two of the three spatial coordinates. TABS-2, on the other hand, requires all three spatial coordinates; and the data file structure is established by the Flow Model, RMA-2V. It is completely different from HEC-2, as can be seen by comparing the

42. The theoretical basis for each of the computer programs is presented in the appendices of this manual. In general, hydraulic computations can be run in a steady-state mode, thereby producing a direct solution of the equations, or they can be run as a dynamic simulation. The sediment computations are structured only for the dynamic mode.

43. Having the full nonlinear equations allows the hydraulic computations to predict large-scale eddies. However, these codes are considered to be far-field codes; that is, they are not designed to resolve eddy and vortex problems close to structures. There is no fluid-structure interaction built into the programs. On the other hand, the codes can calculate the impact of a structure, such as a dike or a bridge pier, on the current pattern; and based on that impact, the resulting erosion or deposition is calculated.

44. Each finite element code requires a computational mesh. Historically, development of the mesh has consumed enormous amounts of study time. The implementation of automatic mesh generators in this system provides a method for streamlining the mesh generation.

45. The finite element method was selected for this system for a number of reasons. Among them are: (a) the solution is continuous over the area of interest, (b) boundary condition specification is extremely flexible, (c) resolution can range from very fine to very coarse in the same mesh, (d) computational cells can be oriented in many directions, and (e) model boundary and interior shapes can be exactly represented. The latter two reasons are particularly important in navigation channel studies where size and channel alignment are so variable. The finite element approach allows computations to be made node by node rather than averaged over an element.

Components of the System

46. Two-dimensional, mobile boundary hydraulics problems are considerably more complex than one can address with a single computer program. Partitioning the overall problem into a set of tasks led to the tasks and computer codes listed in Table 1. Paragraphs 3-7 discuss the major components briefly. For descriptions of the individual programs, see the appropriate appendix.

Files

47. TABS-2 contains two basic file subsystems: (a) the FE Subsystem and (b) the WESDMS Subsystem. The FE Subsystem files are created by and for the primary computation codes: the

PART II: SYSTEM DESIGN

Capability of the System

39. The primary considerations in developing TABS-2 were to produce a systematic numerical method to:

- Establish relations between the factors that cause shoaling problems in navigation channels,
- Quantify the impact of alternatives being considered to possibly reduce the amount of shoaling and dredging in a navigation project,
- Predict the maintenance required for proposed new projects or project improvements.

That objective was accomplished by the development of the TABS-2 modeling system. In fact, the TABS-2 system goes beyond the original objective in that it is capable of analyzing a considerably broader class of problems. It is potentially useful for planning, engineering, and real estate functions as well as construction and operations. Hydraulic computations can be made for fixed-bed problems, if desired, without performing a sediment study at all. The velocity field can be calculated for a ship-tow simulator, for example, and losses at channel junctions can be calculated. Flow around islands and head loss at bridge crossings, particularly where multiple openings are involved, provide a new design capability. The power of the method lies in its ability to calculate the flow pattern across as well as along the flow field.

40. TABS-2 is an uncoupled computation of the mobile boundary hydraulics problem. RMA-2V is executed as a fixed-bed calculation. Resulting hydraulics parameters are passed to STUDH using a file interface, and they are used in the sediment transport computations. When "significant" bed changes are computed by STUDH, a new set of bed elevations is passed back to RMA-2V and hydraulic computations are updated. (Note: STUDH automatically adjusts the magnitude of velocities in the RMA-2V output file in response to calculated bed changes.) The bed structure in STUDH allows 10 layers at each node. Properties of each layer can be independently varied. Consolidation with time and overburden is permitted. Sand transport and clay transport are computed separately.

41. The SPATIAL DATA analysis programs offer a new capability for analyzing and displaying field measurements as well as calculated data sets. Of particular importance is the capability to subtract one spatial data set from another, to summarize the incremental changes between them, and to display the difference as a contour plot or a factor map.

descriptions of and instructions for using the various components of the system.

32. The 2-D approximation involves integrating the governing equations over depth. Thus variations of velocity or constituent concentration with depth are not predicted. Depending upon the degree of variation with depth occurring in the waterway and the desired detail of results, this approximation may or may not be an important factor.

33. Each of the major component programs in the system has specific limitations. See the documentation for each of them for their special limitations.

Future Improvements

34. This report describes version 2.0 of the TABS-2 system. The system and its component programs are undergoing revision to improve their capabilities and performance. Improvements will be documented and reported to system users. Users are encouraged to notify WES of any improvements that they would like to see in the programs or documentation.

Related Systems

35. Both steady-flow and unsteady-flow work are being packaged in the 1-D TABS-1 system. It is designed for long-term simulations--50 to 100 years--and calculates the water-surface and the bed-surface profiles. Two programs that approximate the hydrograph with a histogram of steady flows are being considered: a network version of HEC-6 and quasi-2-D version of HEC-6 (HAD-1) in which flow and sediment movement are calculated by strip. The network code has been applied to several studies, and HAD-1 has been applied to the Atchafalaya Delta and to Canton Reservoir.

36. TABS-3 is the 3-D version of TABS-2; it is presently under development at WES.

37. The TABS-2 system is frequently used in conjunction with a numerical ship and tow simulator. The simulator consists of a minicomputer that solves equations to simulate maneuvers of vessels, a set of pilot controls, and monitors to display visual and radar scenes to the pilot. The ship and tow simulator is described in Appendix C.

Organization of the Manual

38. This user's manual consists of the main text and 15 appendices. The main text provides an overview of the system. Appendix A is a bibliography on related numerical modeling topics; Appendix B is a glossary of terms used; and Appendix C gives details of one system application. Appendices D-0 provide

Applications

29. The range of applicability of the TABS-2 system is still being explored. In general, it should be useful in subcritical flow systems in which armoring is not a major consideration and flow can be described by depth-averaged velocity. It has been used to model both sand movement and the movement of cohesive material. It has been applied in estuaries, rivers, and reservoirs, including those listed below:

River Applications:

Lock and Dam 2, Red River
Lock and Dam 26, Mississippi River
Greenville Reach, Mississippi River
Yazoo Backwater Area Pumping Plant
Upper Mississippi River Tow Navigation
Atchafalaya River at Morgan City
Lock and Dam 3, Red River
Containment Area Design

Tidal Applications:

Columbia River Entrance
Cape Fear River
Atchafalaya Bay
Norfolk Harbor
Chesapeake Bay
New York Harbor
Kings Bay
Terrebonne Marshes
Charleston Harbor
Portsmouth Harbor
Corpus Christi Bay

30. Some of these studies involved the siting of training structures to reduce navigation channel and harbor shoaling. The volume and location of maintenance dredging were key parameters in comparing those alternative plans. In addition, changes in estuarine circulation patterns and salinity intrusion caused by depth changes were calculated for some of the estuarine areas.

Limitations

31. Long continuous simulation studies are not feasible because of the computation cost. Periods on the order of weeks or longer are modeled in piecewise fashion with results extrapolated between successive periods of real-time modeling. Study areas should be made as small as practicable to reduce computational costs.

by W. R. Norton, I. P. King, and Gerald T. Orlob in 1973* with funding from the Walla Walla District, Corps of Engineers. Further details are given in a report to the Association of Bay Area Governments.** The modified code for TABS-2 is presented in the RMA-2V appendix of this manual. In brief, the original version was a mass formulation and that was changed to a velocity formulation of the basic equations resulting in the "V" suffix on the code designator (RMA-2V). A capability to wet and dry portions of the mesh also was added. A number of other revisions have been made by WES personnel.

26. The sediment calculations program, STUDH, is a WES modification of the program written by Ranjan Ariathurai, Robert C. MacArthur, and Ray B. Krone† of the University of California, Davis, for the Dredged Material Research Program of the Corps of Engineers. That original cohesive transport model was modified by WES to transport sand. Ariathurai, who is now with Resource Management Associates, modified his original program for wetting and drying and for element shape, and his results were incorporated into STUDH by Estuaries Division personnel of WES. The bed structure module, provision for combined sand-clay runs, and internal extrapolation are among many WES modifications to the program.

27. The salinity transport program, RMA-4, was obtained from Resource Management Associates. It was originally developed for the East Bay Municipal Utility District, California. WES has revised the program in some ways.

28. The utility programs in the systems came from several sources. The network generator, GFGEN, is a WES modification of RMA-1, which came from Resource Management Associates. The spatial data analysis codes are adaptations of programs developed by V. E. LaGarde, Environmental Laboratory, WES. The TABS-2 data management system was developed by WES Hydraulics Laboratory personnel. The automatic mesh generator AUTOMSH is composed of two codes obtained from Sandia National Laboratories, entitled QMESH and RENUM, plus WES-generated interface codes. Most of the other codes were designed and written by WES Hydraulics Laboratory personnel.

* W. R. Norton, I. P. King, and G. T. Orlob. 1973. "A Finite Element Model for Lower Granite Reservoir," prepared for US Army Engineer District, Walla Walla, Wash.

** W. R. Norton and I. P. King. 1977. "Operating Instructions for the Computer Program, RMA-2," Resource Management Associates, Lafayette, Calif.

† R. Ariathurai, R. C. MacArthur, and R. B. Krone. 1977 (Oct). "Mathematical Model of Estuarial Sediment Transport," Technical Report D-77-12, US Army Engineer Waterways Experiment Station, Vicksburg, Miss.

substantial effort is made in an attempt to minimize the number of nodes while adequately capturing significant geometry and hydraulic features in 2-D work.

20. The 2-D hydraulic code, like a 1-D code, can be run as a steady-state solution or it can be run as a dynamic simulation. For a steady-state case, the tailwater elevation is prescribed along with the inflow of water and the program calculates the water surface, u-velocity, and v-velocity at each node. Manning n-values are used for friction roughness and turbulent losses are accounted for with diffusion coefficients; calibration is required to reproduce observed prototype water-surface elevations. Water-surface profiles from 1-D computations are straightforward, but less so with results from the 2-D models. This system will plot a water-surface contour map of the modeled area. In addition, velocity vectors and unit discharge vectors can be obtained.

21. The above discussions addressed hydraulic calculations. Sediment calculations in this system are somewhat less advanced than those in HEC-6 in some respects. For example, only a single grain-size sediment can be analyzed, and armoring is not addressed. However, the objective of calculating bed-surface elevations for feedback to hydraulics is achieved. Since calculations are node by node, the cross-section shape can deform depending on hydraulics and inflowing sediment load. Work is under way to add more sophisticated calculations to TABS-2.

22. A major difference between the 2-D and 1-D modeling is the cost. A 1-D model can simulate system behavior for years, for about the same costs as the 2-D model can simulate for a few days. It is necessary to use a statistical approach to make annual as well as long-term projections.

23. Neither the 1-D nor the 2-D sediment models are designed for local scour. It is possible, however, to code embankment and pier details into the 2-D model and calculate that portion of erosion resulting from the contraction and the resulting nonuniform discharge distribution. That leaves only the turbulence-generated scour as undefined.

Origin of the System

24. TABS-2 was assembled by personnel in the Estuaries Division and the Hydraulic Analysis Division, Hydraulics Laboratory, US Army Engineer Waterways Experiment Station (WES). It was operated on the CRAY 1 computer, Boeing Computer Services, from 1980 through September 1983 when the Corps of Engineers began shifting work to CYBERNET according to the new contract for ADP services.

25. The individual codes in the system came from several sources. The first to be developed was RMA-2. It was completed

procedures are useful in every study. These are presented in this manual.

15. This document does not show the complete theoretical development of the computer programs. References are made to other reports where details are presented. The development of "representative data" is generally beyond the scope of this document, and yet that is the key to most successful modeling studies. The criteria to use in assessing numerical model performance depend upon the specific model and the questions being asked of it. Only limited material is presented in this document for assessing model performance criteria. The absence of diagnostics and error messages does not guarantee satisfactory model performance.

A Comparison of 1-D and 2-D Numerical Modeling

16. The one-dimensional (1-D) backwater calculation is a familiar numerical model in which river cross sections are described, a tailwater elevation is established, a water discharge is established, and the resulting water-surface profile is calculated by solving the 1-D form of the energy equation. In that calculation, the geometry is described by cross section and reach lengths (i.e., the distance between cross sections). The alignment of each cross section should make it perpendicular to the approaching flow. Although the location of the cross section is frequently shown on the study area map, that section should be replaced by a single computation node to depict the reality of the 1-D solution. Although the cross sections can be irregular in shape, the resulting calculated velocity is but an average.

17. The 2-D model on the other hand, does not work directly from cross sections. However, there is still a requirement for geometry. This is satisfied by the finite element (FE) mesh. One significant difference is that the computation points (i.e., the NODES) do not have to be in a straight line perpendicular to the flow. Since the equations are continuous in space, which is characteristic of the finite element method, the computation points can fall in a random pattern. However, it is desirable to be systematic, so that many times the nodes will appear to lie along cross sections perpendicular to the flow.

18. In coding cross sections for 1-D computations, as many as 100 points are sometimes used. That is not the case with the 2-D geometry. Only one elevation point is permitted at each corner node and the program assumes a straight-bottom line between corner nodes. Therefore, if the FE mesh is seven elements wide, the cross section will be defined by eight bed elevations. That may not capture the true prototype, cross-section geometry.

19. On the other hand, the 1-D models solve simplified equations at each cross section, whereas the 2-D models solve more, and more complex, equations at every node. As a result,

74. The finite element mesh is shown in Figure 4. It contains 336 elements and 1,078 nodes. Sandbars and dikes complicate the mesh development as illustrated in the inset to Figure 4. The Leland bar dike No. 4 is located at about river mile 537 on the right bank side of the channel. It is about 1,500 ft long and 30 ft high at the outer end, and it is built into the mesh by five elements. During high flows, it is entirely submerged, but during low flows, this structure is out of the water. Numerous other dikes, functioning and coded in the same fashion, are visible along this reach of the river.

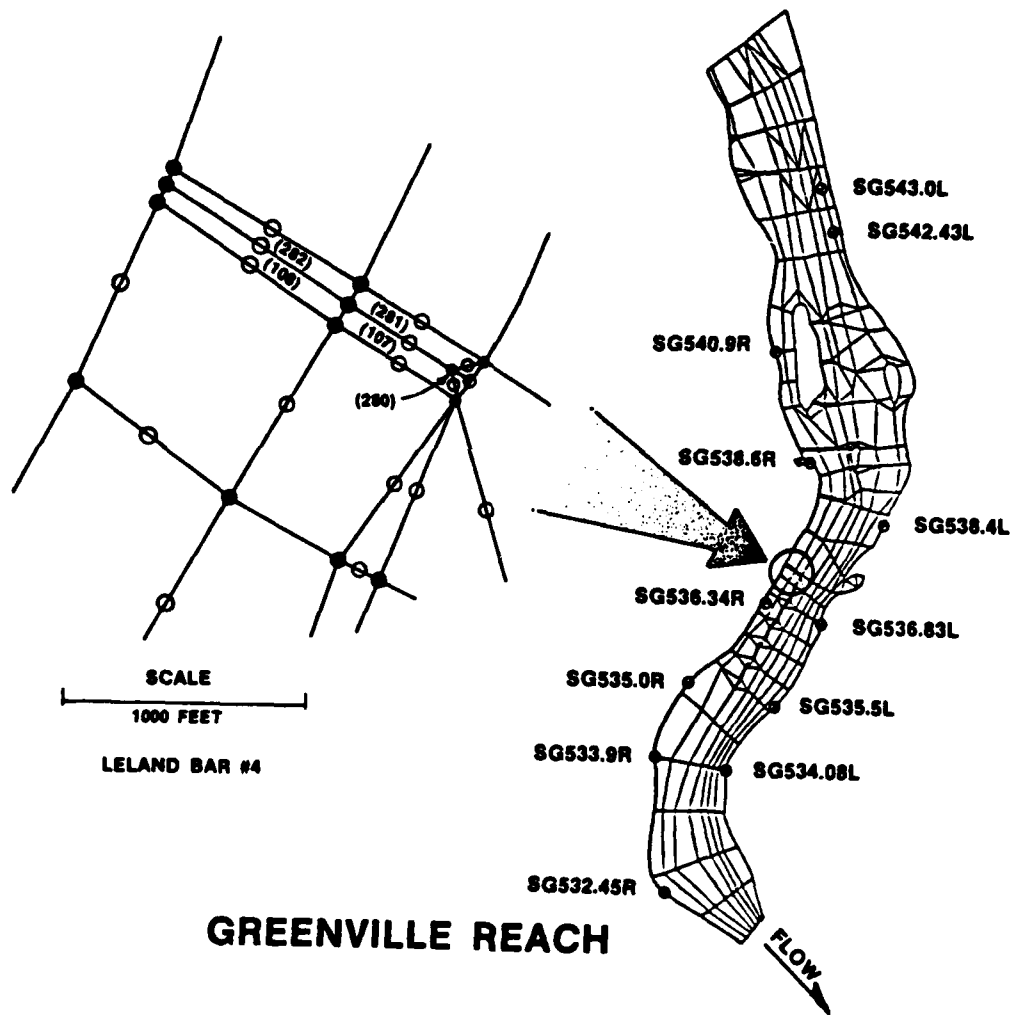

Figure 4. The finite element mesh, Greenville reach

75. Another type of dike in the Greenville reach is the vane dike. It is positioned in the channel at a slight angle to the current and is not attached to the bank. There are five vane dikes in the Greenville reach, each one requiring four elements to model its shape and size. The resulting mesh provided the necessary resolution for the computations.

76. The hydrographic survey of 9 March 1981 was digitized and incorporated in the computation mesh. Depths ranged from 5 to 75 ft. The corresponding water discharge and water-surface elevation at the Greenville Bridge gage, 677,500 cfs and 104.2 ft NGVD, respectively, were encoded as boundary conditions. The n -values and eddy viscosity coefficients, E , were assigned as follows:

Feature	n -Values	E_{xx}	E_{yy}	E_{xy}	E_{yx}
River channel elements	0.0275	250	250	250	250
Dike-field elements	0.043	250	250	250	250
Vane-dike elements	0.045	250	250	250	250
Other dike elements	0.055	250	250	250	250

77. Three model responses were observed: Water-surface elevations, current patterns/velocity distributions, and unit discharge at a cross section. Model and prototype water surfaces are shown in Figure 5. Model results were within 1/2 ft of the

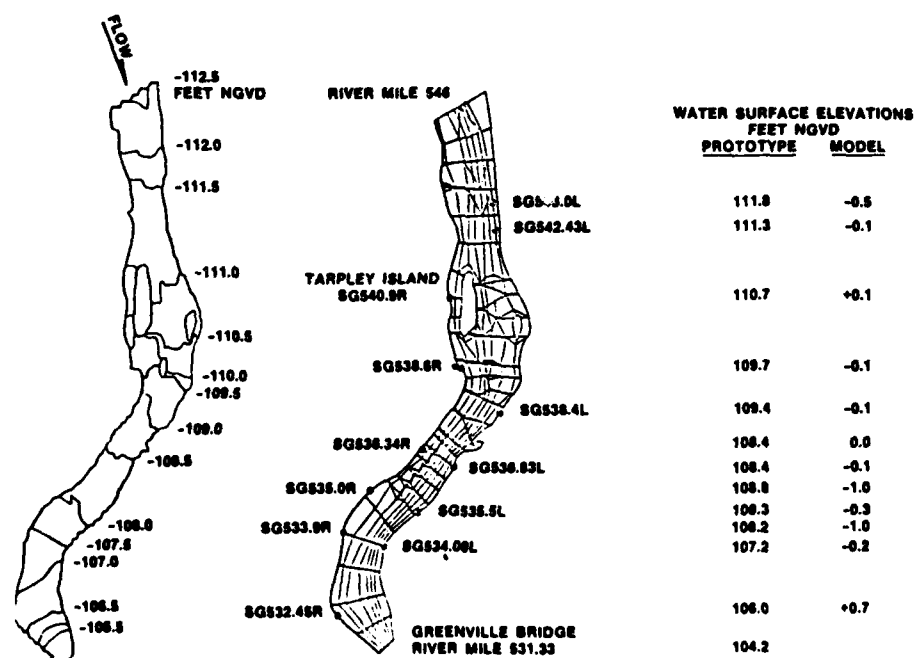

GREENVILLE REACH (Q = 677,500 CFS, 9 MARCH 1981)

Figure 5. Water-surface elevations

prototype except for three gages where the difference ranged up to 1 ft. Most gages were within a tenth of a foot. In addition to the tabular data at gages, contours of the water surface were developed. Of particular interest is the steep gradient, on the inside of the bend, between elevation 109 and 111.

78. Figure 6 shows the model velocity vectors near Tarpley Island. The dots are float positions taken at 30-sec intervals. Vector lengths were scaled so perfect agreement is three dots long. The results, both in magnitude and direction, were very good. (Note the eddies forming downstream of the Tarpley Island Dike.)

79. Not only velocity vectors but also flow distribution matched prototype data remarkably well as shown in Figure 7. The calculated flow distribution around Tarpley Island matches prototype measurements within 2 percent.

80. Figure 8 shows two vector plots--one for velocity and one for unit discharge. To obtain greater readability, the horizontal scale is compressed. Both plots show the greatest intensity crossing from the left bank to the right bank just upstream from Greenville Bridge. The unit discharge vectors show a narrow band of high discharge that is of importance to sediment and channel alignment studies, whereas the velocity vectors show the most information for navigation studies.

81. In general, the codes performed well. Wetting and drying of elements caused some numerical problems that can only be solved by relatively small element sizes at present. The application took about 2 months and served as a training aid in addition to testing the code performance.

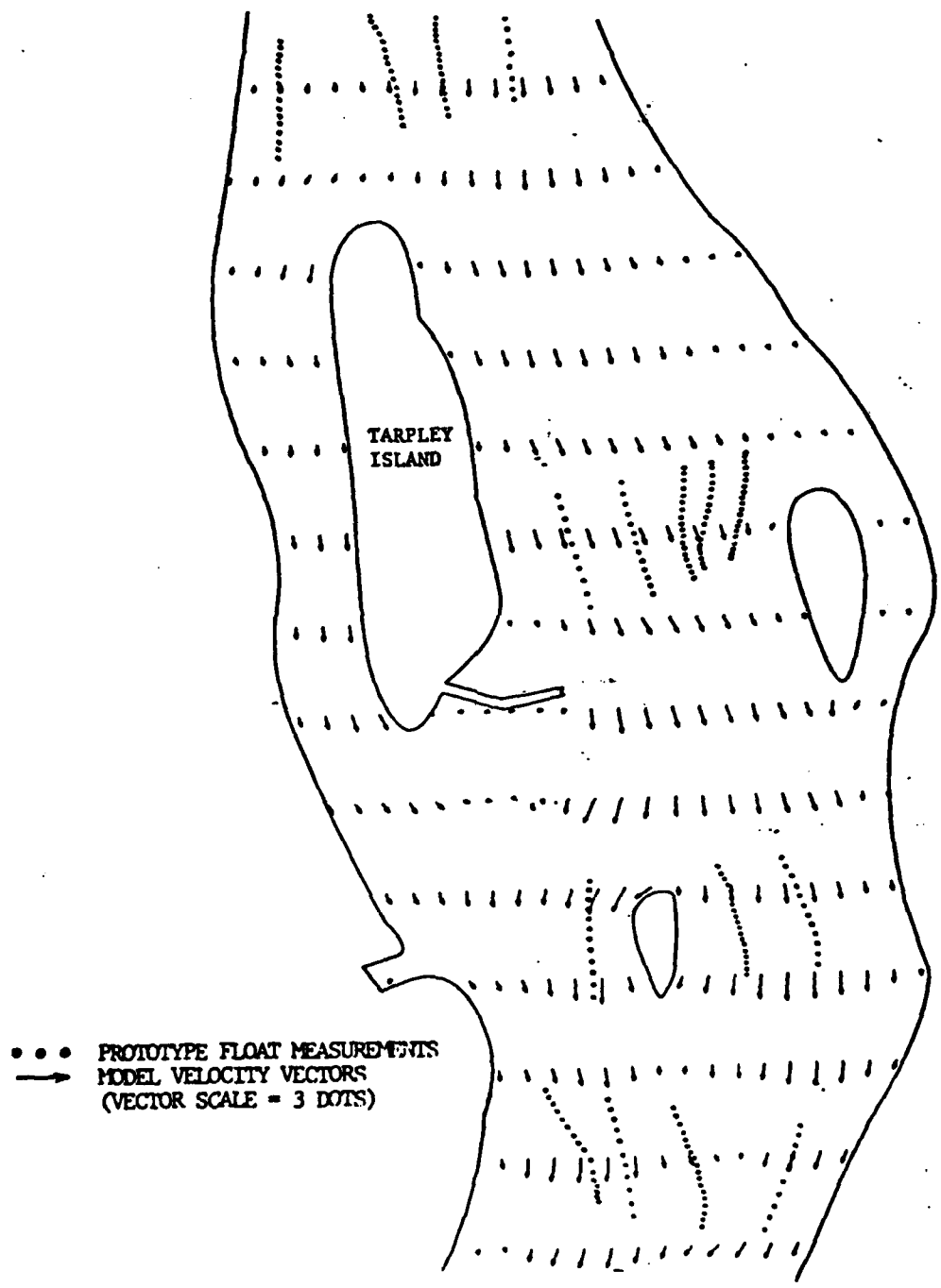

Figure 6. Comparison of model and prototype velocities, Greenville reach

GREENVILLE REACH
 COMPARISON OF MEASURED AND COMPUTED FLOW DISTRIBUTION

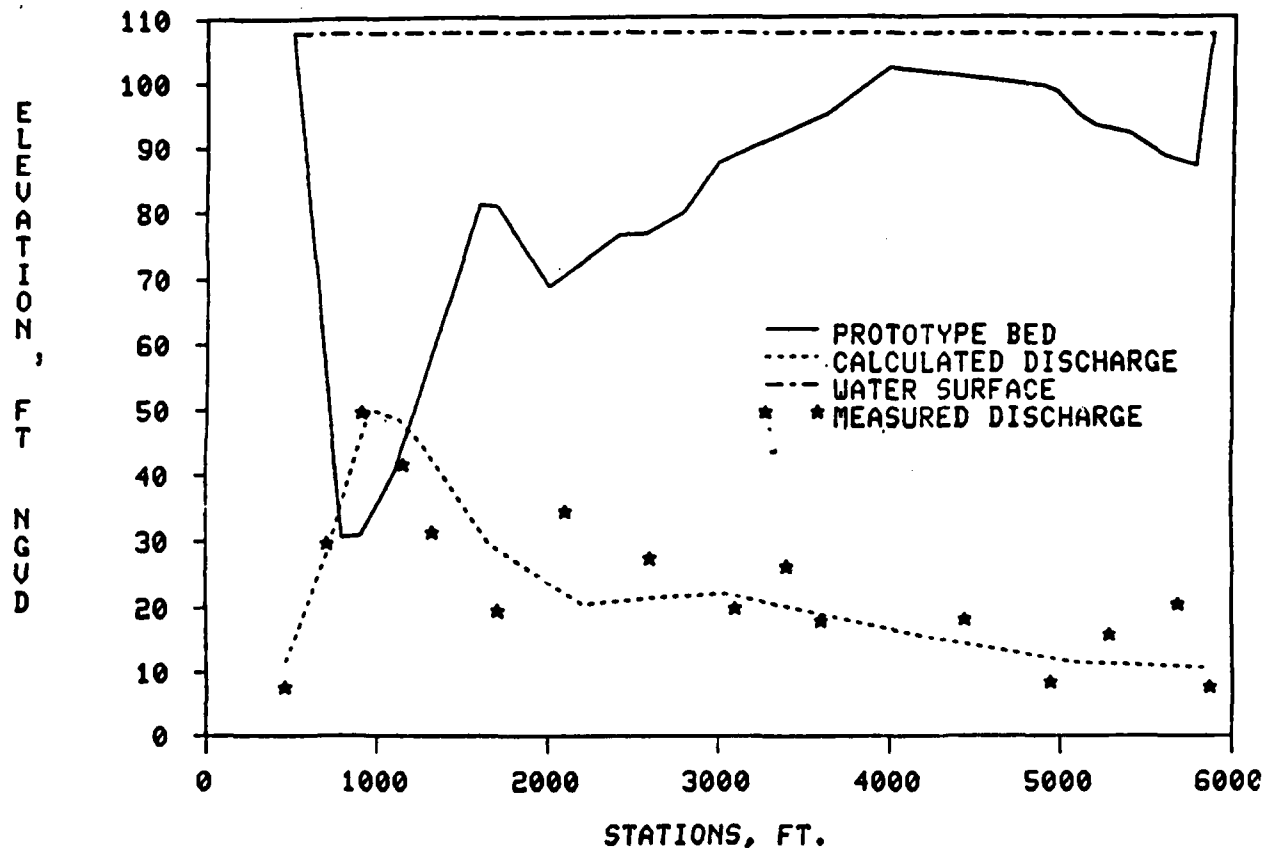
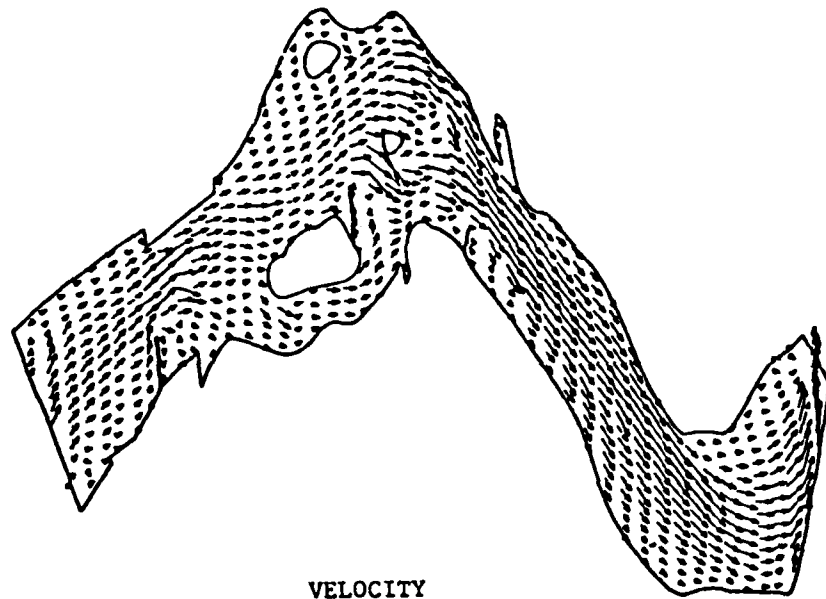
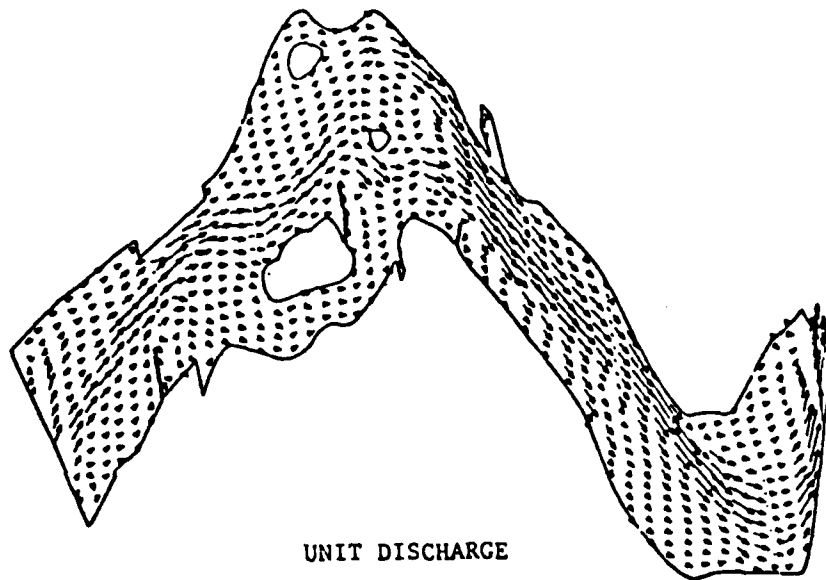

Figure 7. Flow distribution comparison



VELOCITY



UNIT DISCHARGE

Figure 8. Vector plots, Greenville reach

PART V: INDEX OF PROGRAMS

82. Several indices are provided to help the user locate programs within this manual. An index of programs by categories appears after the table of contents. Table 1 lists the major task categories and the programs that accomplish those tasks. Table 3 lists the programs and procedures by name and gives the manual location that describes their use. Each appendix contains a table of contents listing the programs contained there.

Table 1
TABS-2 Tasks and Programs

Task	Purpose	Computer Programs
DIGITIZING	<ul style="list-style-type: none"> o Create a digital map of the study area in (x,y,z) coordinates. o Establish the (x,y) coordinates for the boundary around the finite element mesh and in complex studies, boundaries of each subregion in that mesh. 	MESH DMSDIC
MESH GENERATION	<ul style="list-style-type: none"> o Locate computation nodes in the study area and link them together into elements. o Assign element types, first external boundary nodes, calculate curved sides, and produce the input file for RMA-2V geometry in the proper forms 	AUTOMSH GFCEN EDGRG
FLOW MODELING	<ul style="list-style-type: none"> o Calculate water-surface elevation, the u-velocity and the v-velocity for a specific set of boundary conditions. 	RMA-2V
SEDIMENT MODELING	<ul style="list-style-type: none"> o Calculate the concentration of sediment in the flow, erode transport and deposit, and change bed elevations at each node. 	STUDH
TRANSPORT MODELING	<ul style="list-style-type: none"> o Calculate the salt, temperature, or other constituent concentration in the flow field. 	RMA-4
SPATIAL DATA MANAGEMENT	<ul style="list-style-type: none"> o Transform randomly spaced data to a uniform grid (i.e., such as velocities from RMA-2V to a uniform spacing for plotting). o Interpolate gridded data from one cell size to another. o Interpolate from gridded data to irregularly spaced points (i.e., such as extracting nodal elevations from the digital map file). o Subtract two spatial data sets. o Create a factor map. 	ELEVGRD TRANSA RETPNT GRDSUB FACGRD
GRAPHICAL OUTPUT	<ul style="list-style-type: none"> o Plot velocity vectors. o Plot contour maps. o Plot drogue path from RMA-2V output. 	VPLOT CONTOUR DROGUEPLOT SEDGRAF
OUTPUT ANALYSIS	<ul style="list-style-type: none"> o Analytical and statistical summaries. o Comparisons of one data set or result with another - as model to prototype. o Accumulations of rates into volumes. 	POSTSED POSTHYD ACE
FILE MANAGEMENT	<ul style="list-style-type: none"> o Store, retrieve, and provide common analysis of temporal, spatially distributed data sets. o Maintain a history and "family tree information" of the contents in a file. 	
INTERFACES	<ul style="list-style-type: none"> o Change output from one code into form required to input to another. o Jobstream model runs from coarse meshes to inset meshes. 	ENGMET JOBSTREAM
JOB SUBMISSION	<ul style="list-style-type: none"> o Automatic job control language. o Submit batch jobs to computer. o Track job's progress. 	PROCLV

Table 2

Summary of Steps for a Typical Applications

-
1. Prepare statement of purposes and end products desired.
 2. Assemble available prototype information--charts, maps, flow measurements, etc.
 3. Sketch mesh limits and element layout.
 4. Refine mesh sketch, number nodes and elements (manually or by AUTOMSH), and set up connection table.
 5. Establish boundary condition nodes.
 6. Identify nodes on curved boundaries and assign slopes.
 7. Digitize manually developed mesh or region boundaries for automatic mesh generation.
 8. Edit and merge files for GFGEN input.
 9. Run GFGEN or (EDGRG), then edit slope error problems.
 10. Rerun GFGEN until all major slope errors are fixed and network is reordered efficiently.
 11. Create RMA-2V run control file for steady-state, flat-bottom leak test and run.
 12. If mesh leaks, correct problems.
 13. Install actual bed elevations, then rerun leak test. Correct leaks and oozes.
 14. Run RMA-2V verification tests.
 15. Run RMA-2V base test.
 16. Create STUDH run control file with nonerodible bed and constant boundary concentrations. Run short test and correct any problems that occur.
 17. Modify STUDH run control file to show desired bed condition and initial and boundary conditions. Run initial test and correct any problems that appear.
 18. Run STUDH verification tests.
 19. Run STUDH base tests.
 20. Revise computational mesh as needed for plan to be tested.
 21. Run RMA-2V plan tests.
 22. Produce graphical and tabular hydrodynamic results output.
 23. Run STUDH plan tests.
 24. Produce graphical and tabular sedimentation results output.
 25. Report results.
-

Table 3
Program Name Index

<u>PROGRAM</u>	<u>PURPOSE</u>	<u>APPENDIX</u>	<u>PAGE</u>
ACE	Assemble STUDD events, compute bed change and dredging volumes, plot sediment transport vectors.	J	J-1-1
AUTOMSH	Create computational meshes.	D	D-1-1
BATHVOL	Compute volume of sediment difference between two surveys.	L	L-15-1
BIN2FOR	Transform binary model output files to formatted files.	J	J-3-1
BTHAREA	Compute areas within contours.	L	L-14-1
CONFEG	Convert digitizer file to GFGEN format	E	E-3-1
CONTOUR	Plot contour map of specified data.	I	I-1-1
DROGUEPLT	Plot path of a drogue moving with current.	I	I-2-1
DMSDIG	Digitize data from a map or graph.	L	L-1-1
DGPLT	Plot digitized data for checking.	L	L-2-1
DIRECT	Display a plot on a graphics device.	I	I-3-1
DUMPER2	Print gridded data in swaths.	L	L-16-1
EDGRG	Edit computational network interactively.	D	D-2-1
ELEVGRD	Create standard DMS data format file from randomly spaced data.	L	L-10-1
ENGMET	Translate RMA-2V output from English units to SI units for use by STUDD.	M	M-1-1
FNDNODE	Locate a node in a computational mesh.	D	D-5-1
FACGRD	Set up factor or patch map.	L	L-12-1
FO2UN	Transform formatted file to DMS binary form.	L	L-5-1
FOR2BIN	Transform formatted model output files to binary files.	J	J-4-1
4VIEW	Plot psuedo-3-D graphs.	I	I-4-1

(Continued)

(Sheet 1 of 3)

Table 3 (Continued)

<u>PROGRAM</u>	<u>PURPOSE</u>	<u>APPENDIX</u>	<u>PAGE</u>
GET	Accumulate STUDH output results for use by ACE.	J	J-1-1
GFGEN	Create geometric data file for use by models.	D	D-3-1
GCS/META	METAPLOT version of GCS.	I	I-5-1
GRDSUB	Subtract one set of gridded data from another and writes results to a file.	L	L-13-1
JOBSTREAM	Compute boundary conditions for an inset computational network from results of a larger network model run.	M	M-2-1
MESH1	Merge tabular data into a gridded data set.	L	L-7-1
MESH2	Merge standard hydrographic survey data into a gridded data set.	L	L-8-1
MESH3	Merge gridded data from several maps.	L	L-9-1
METAPLOT	Produce graphics output files.	I	I-6-1
POSTHYD	Analyze results of an RMA-2V run and plot time-histories.	J	J-3-1
POSTSED	Summarize results of a STUDH run.	J	J-2-1
PROCLV	Construct job control language and submit batch jobs to run programs.	O	O-1
RETPNT	Interpolate gridded data to provide data at specified points.	L	L-11-1
REFMT	Convert special digitizer data files to standard format.	L	L-3-1
RMA-2V	Compute 2-D flow and water levels	F	F-1
RMA-4	Compute transport of dissolved and suspended substances.	H	H-1
SEDGRAF	Produce factor map of STUDH results.	I	I-3-1
STUDH	Compute transport, erosion, and deposition of sediments.	G	G-1

(Continued)

(Sheet 2 of 3)

Table 3 (Concluded)

<u>PROGRAM</u>	<u>PURPOSE</u>	<u>APPENDIX</u>	<u>PAGE</u>
TRANSA	Transform data from one grid system to another.	L	L-4-1
UN2FO	Transform binary form data to formatted form.	L	L-6-1
VPLOT	Produce vector plots of RMA-2V velocity results.	I	I-7-1
WDGPI.T	Plot wet and dry areas of computational mesh.	I	I-8-1

END

FILMED

10-85

DTIC