

MICROCOPY RESOLUTION TEST CHART
 NATIONAL BUREAU OF STANDARDS-1963-A

AD-A159 262

12 AD-A159262

SECURITY CLASSIFICATION OF THIS PAGE

REPORT DOCUMENTATION PAGE

1a. REPORT SECURITY CLASSIFICATION Unclassified		1b. RESTRICTIVE MARKINGS	
2a. SECURITY CLASSIFICATION AUTHORITY		3. DISTRIBUTION / AVAILABILITY OF REPORT As required to Defense Documentation Center, individuals and organizations on ONR program	
2b. DECLASSIFICATION / DOWNGRADING SCHEDULE		4. PERFORMING ORGANIZATION REPORT NUMBER(S) Report No. 1	
5. MONITORING ORGANIZATION REPORT NUMBER(S) N-00014-83-C0141		6a. NAME OF PERFORMING ORGANIZATION Honeywell Ceramics Center	
6b. OFFICE SYMBOL (If applicable)		7a. NAME OF MONITORING ORGANIZATION	
6c. ADDRESS (City, State, and ZIP Code) 5121 Winnetka Avenue North New Hope, MN 55428		7b. ADDRESS (City, State, and ZIP Code)	
8a. NAME OF FUNDING / SPONSORING ORGANIZATION Office of Naval Research		8b. OFFICE SYMBOL (If applicable)	
9. PROCUREMENT INSTRUMENT IDENTIFICATION NUMBER		10. SOURCE OF FUNDING NUMBERS	
8c. ADDRESS (City, State, and ZIP Code) Division of Materials Research 800 N. Quincy Arlington, VA 22217		PROGRAM ELEMENT NO.	PROJECT NO.
		TASK NO.	WORK UNIT ACCESSION NO.
11. TITLE (Include Security Classification) Crack Propagation in Z5U Multilayer Dielectrics			
12. PERSONAL AUTHOR(S) K. D. McHenry and B. G. Koepke			
13a. TYPE OF REPORT Technical	13b. TIME COVERED FROM 6/1/83 TO 5/31/84	14. DATE OF REPORT (Year, Month, Day) 5/1/85	15. PAGE COUNT
16. SUPPLEMENTARY NOTATION			
17. COSATI CODES		18. SUBJECT TERMS (Continue on reverse if necessary and identify by block number)	
FIELD	GROUP	SUB-GROUP	
		Crack propagation, fracture toughness, multilayer dielectrics	
19. ABSTRACT (Continue on reverse if necessary and identify by block number)			
<p>It has been found that moisture has a deleterious effect in enhancing slow crack growth in Z5U multilayer ceramics similar to the effect shown in other ceramic materials. The enhancement of slow crack growth in the presence of moisture has been demonstrated for both parallel and perpendicular orientations of the multilayer structure with respect to the propagating crack. The application of DC electric fields to the multilayer ceramics either has no effect or serves to retard crack propagation depending upon the crack orientation with respect to the applied electric field.</p> <p>The fracture toughness or critical stress intensity factor as measured by the double torsion testing technique has been found to vary with</p>			
20. DISTRIBUTION / AVAILABILITY OF ABSTRACT <input checked="" type="checkbox"/> UNCLASSIFIED/UNLIMITED <input type="checkbox"/> SAME AS RPT. <input type="checkbox"/> DTIC USERS		21. ABSTRACT SECURITY CLASSIFICATION Unclassified	
22a. NAME OF RESPONSIBLE INDIVIDUAL		22b. TELEPHONE (Include Area Code)	22c. OFFICE SYMBOL

SEP 17 1985

A

10V
release and
unclassified

Cont 4

SECURITY CLASSIFICATION OF THIS PAGE

respect to orientation of the multilayer structure. Higher fracture toughness values are obtained when the macroscopic crack is forced to propagate in a direction perpendicular to the multilayer structure

Notes on file

A1



SECURITY CLASSIFICATION OF THIS PAGE

TABLE OF CONTENTS

Section		Page
	ABSTRACT	1
I	INTRODUCTION	2
II	EXPERIMENTAL PROCEDURE	7
	A. Subcritical Crack Growth Testing	7
	B. Fracture Toughness Testing	8
	C. Material and Testing Environments	9
	D. Composite Specimen Fabrication	9
III	RESULTS AND DISCUSSION	12
	A. Compliance Measurements	12
	B. Subcritical Crack Growth	14
	1. Environmental Effects	14
	2. Electrical Effects	16
	3. Orientation Effects	18
	C. Fracture Toughness	22
	D. Mechanisms	22
IV	CONCLUSIONS	24
	REFERENCES	25

ABSTRACT

This technical report summarizes the progress made during the period June 1, 1983 - May 31, 1984 under Contract N00014-83-C0141 entitled ELECTROMECHANICAL INTEGRITY OF MULTILAYER DIELECTRIC AND PIEZOELECTRIC CERAMICS for the Office of Naval Research. During the first phase of the program, emphasis has been placed on the characterization of slow crack growth and fracture toughness of Z5U multilayer capacitor bodies as a function of environment (both chemical and electrical) and orientation of the multilayer structure.

It has been found that moisture has a deleterious effect in enhancing slow crack growth in Z5U multilayer ceramics similar to the effect shown in other ceramic materials. The enhancement of slow crack growth in the presence of moisture has been demonstrated for both parallel and perpendicular orientations of the multilayer structure with respect to the propagating crack. The application of DC electric fields to the multilayer ceramics either has no effect or serves to retard crack propagation depending upon the crack orientation with respect to the applied electric field.

The fracture toughness or critical stress intensity factor as measured by the double torsion testing technique has been found to vary with respect to orientation of the multilayer structure. Higher fracture toughness values are obtained when the macroscopic crack is forced to propagate in a direction perpendicular to the multilayer structure.

CRACK PROPAGATION IN Z5U MULTILAYER DIELECTRICS

I. INTRODUCTION

The use of multilayer ceramics in critical systems such as those used for navigation, guidance or surveillance has steadily been increasing over the past several years as multilayer technology has been extended to various ceramic materials. Multilayer BaTiO_3 based capacitors and alumina chip carriers have found wide spread usage in military as well as commercial applications. The multilayer technology has recently been applied to PZT materials, specifically for Naval applications, with the anticipated benefits including reduced drive voltages. In all of these applications, reliability of the actual component is of prime consideration. A great deal of effort has been expended on the development and implementation of reliable proof tests for sorting out faulty elements. Most capacitor elements produced today are 100% proof-tested. The basis of these proof tests is usually some electrical parameter of the element such as insulation resistance or capacitance. These type of tests are effective in screening out severely defective elements but may not eliminate components with very small flaws.

The basic structure of a monolithic ceramic body is schematically shown in Figure 1.⁽¹⁾ The individual layers may be anywhere from 25 to 125 microns (0.001 to 0.005") thick for multilayer capacitors up to over 600 microns (0.025") thick for multilayer monolithic PZT bodies. The individual layers are usually punched out of sheets of tape cast material, electroded, laminated and cofired as a single body. A variety of processing and/or production related defects may become apparent in such a structure. These defects are schematically shown in Figure 2⁽¹⁾ and include:

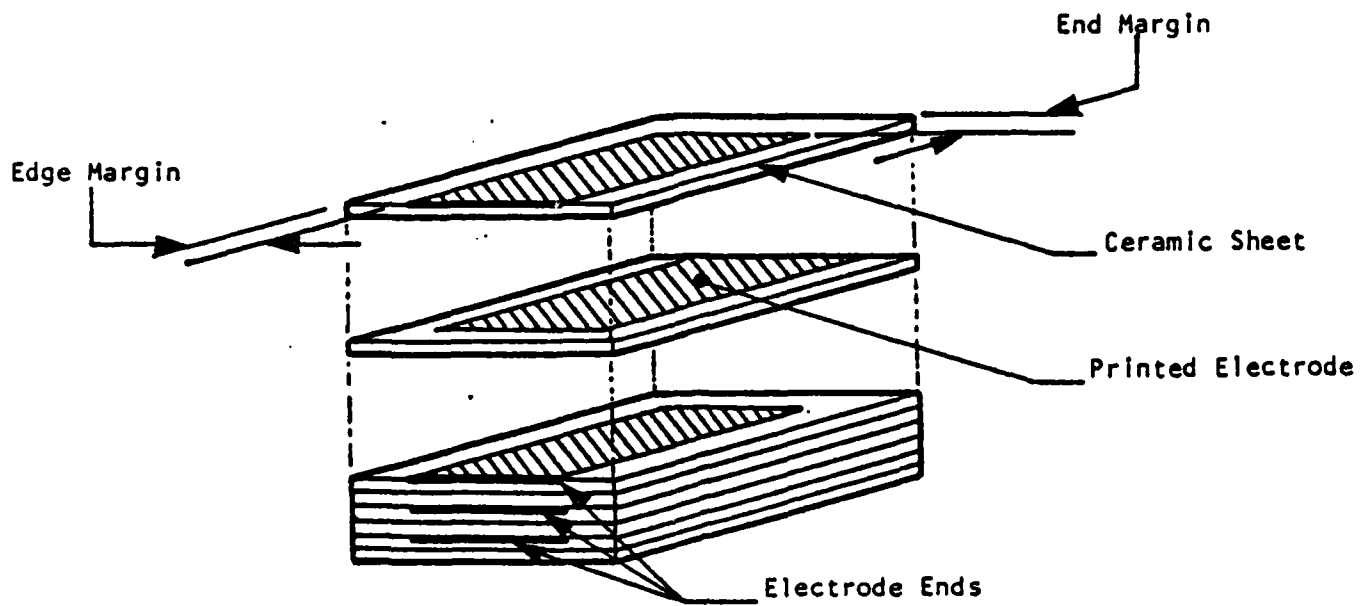
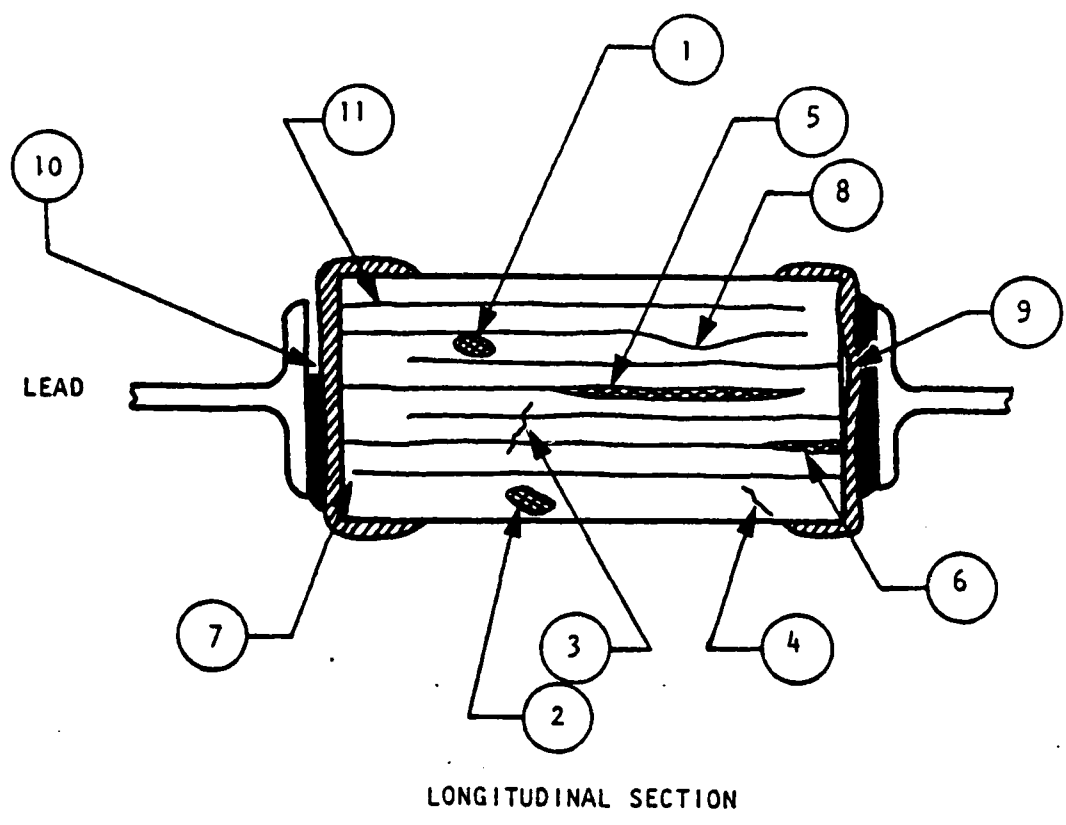
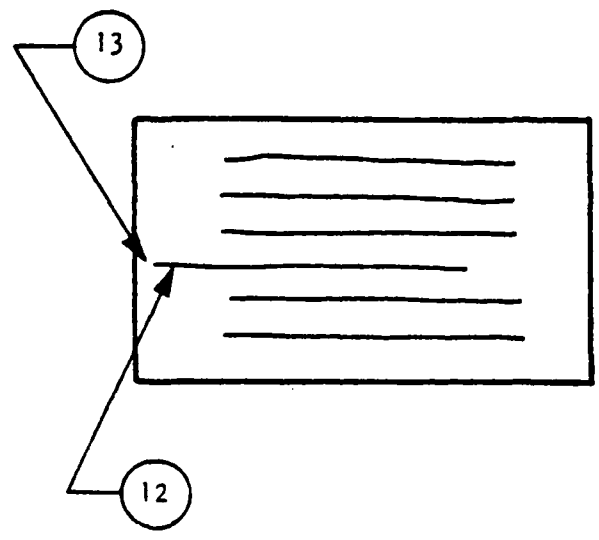

FIGURE 1: MONOLITHIC CAPACITOR STACKING ARRANGEMENT



LONGITUDINAL SECTION



TRANSVERSE SECTION

FIGURE 2: CROSS-SECTIONED CAPACITORS

1. Void in dielectric material between opposed electrodes
2. Void in dielectric material outside of active electrode structure.
3. Crack between opposed electrodes
4. Crack from electrode to outside surface
5. Delamination of adjacent layers
6. Delimitation from an electrode to opposite termination
7. End margin too short
8. Excessive variation of dielectric thickness
9. Inadequately bonded end metallization
10. Poorly attached lead
11. Improper stacking
12. Improper registration
13. Inadequate side margin

In applications where multilayer ceramic components are subjected to mechanical stress, any or all of the defects listed above may have a deleterious effect on the long term reliability of the component due to subcritical flaw growth. This flaw growth may actually lead to premature failure of the component either by catastrophic failure or electrical breakdown. Flaw growth in bulk dielectric and piezoelectric materials has been studied for some time ^(2,3). Much less work has been performed in determining subcritical crack growth characteristics of multilayer ceramic materials ^(4,5).

In this report, we summarize the first year's effort of a program established to determine the fracture characteristics and anelastic deformation behavior of multilayer barium titanate capacitor materials and multilayer monolithic PZT materials. The bulk of the work performed in the first year has concentrated on the fracture behavior of multilayer capacitor materials.

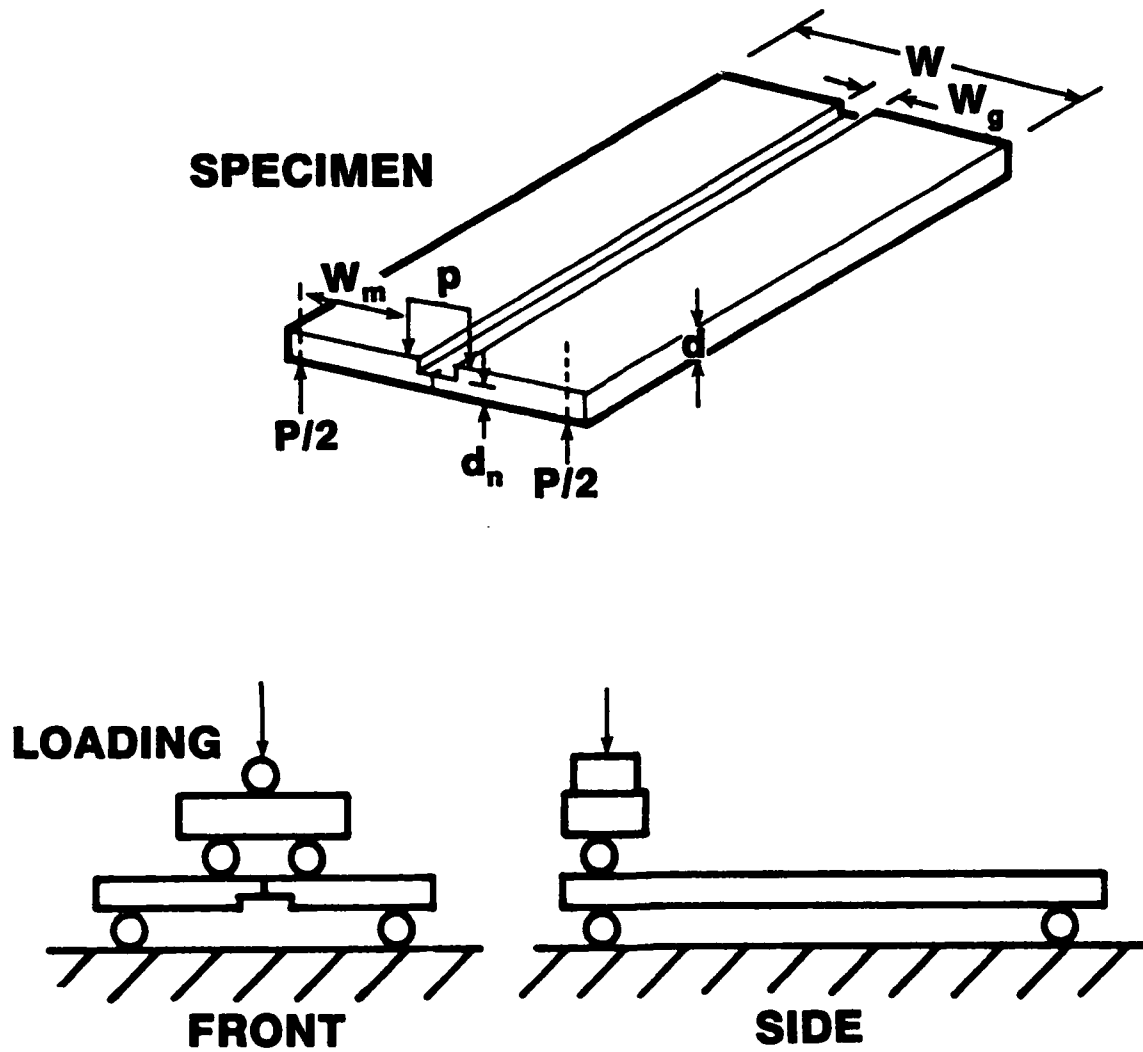

FIGURE 3: Schematic Double Torsion Specimen and Loading Geometry

II. EXPERIMENTAL PROCEDURE

A. SUBCRITICAL CRACK GROWTH TESTING

Subcritical crack growth in the multilayer capacitor material was studied using the double torsion (DT) technique popularized by Evans et al. (6,7). A schematic illustrating the specimen and loading geometry is shown in Figure 3. For this geometry, the stress intensity is independent of crack length over a majority of the specimen length and is given as

$$K_I = PW_m [3(1+\nu)/Wd^3d_n]^{1/2} \quad (1)$$

where P is the applied load, ν is Poisson's ratio of the material, and the other terms are defined in Figure 3. The slow crack growth was obtained using the dead-weight loading technique which the authors have used in past work on bulk PZT materials (8). In this particular testing technique, a precracked specimen is subjected to a fixed applied load P less than the critical load necessary to cause catastrophic failure, P_{IC} . The deflection of the specimen is monitored by a Daytronic LVDT. If subcritical crack growth occurs, a linear increase in deflection is observed with time for a given crack velocity. Providing the compliance of the specimen is a linear function of crack length, it can be shown that the crack velocity is related to the fixed applied load and the rate of deflection according to (7).

$$V = (1/BP) (dy/dt) \quad (2)$$

where B is the slope of the compliance curve (specimen deflection vs applied load at various crack lengths), P , is the applied load and dy/dt is the measured deflection rate. Unlike the load relaxation testing technique where a complete (K_I - V) curve can

be theoretically obtained from one relaxation test, the dead weight loading technique yields one data point per test. To obtain other points, the applied load must either be increased or decreased and the corresponding change in deflection rate measured.

The specimens used in the tests were plates measuring 2.4 cm (0.95") long, 1.8 cm (0.7") wide and 0.9-1.0 cm (0.035-0.040") in thickness. It was found early in the program that side grooves were unnecessary in assuring that the crack ran down the center of the specimen. In a few cases the crack would propagate out of the center line and these data were discarded.

In a typical test, a specimen was loaded at a very low deflection rate (typically 0.005 cm/min) in an Instron Testing Machine until a crack was initiated, indicated either by a rapid decrease in load or a leveling of the load. The specimen was then unloaded and transferred to the dead weight loading fixture for subcritical crack growth measurements. Depending on the applied load and the resultant crack velocity obtained, anywhere from 3 to 10 individual (K_I -V) data points could be collected from each specimen.

B. FRACTURE TOUGHNESS TESTING

The fracture toughness or critical stress intensity factor, K_{IC} , was measured under rapid loading conditions in the Instron Testing Machine. A precracked specimen was loaded to failure at a deflection rate of 0.125 cm/min. The load at failure or critical load at fracture, P_{IC} , was used in Equation 1 to calculate K_{IC} ,

stresses from the application of electric fields. Such compressive stresses would be oriented in a direction perpendicular to the propagating crack and be expected to impede crack propagation.

C. FRACTURE TOUGHNESS

The fracture toughness values obtained for this material are shown in Table 1. A number of samples were tested in each orientation with the general result being that the fracture toughness of specimens tested in the parallel orientation tends to be lower than those in the perpendicular orientation. This supports the slow crack growth data where cracks were seen to propagate at a certain velocity at lower applied stress levels in the parallel orientation. The degree of scatter is not as evident in the fracture toughnesses if one considers just the standard deviations given. The one low value of fracture toughness for Sample #7 in the perpendicular orientation serves to increase the standard deviation of the average.

D. MECHANISM

The mechanism whereby crack propagation is hindered in specimens with an electric field applied perpendicular to the crack is postulated to be a phenomenon of electrostriction. This theoretical analysis is currently being developed in conjunction with the Pennsylvania State University Materials Research Laboratory and will be the subject of a future technical report.

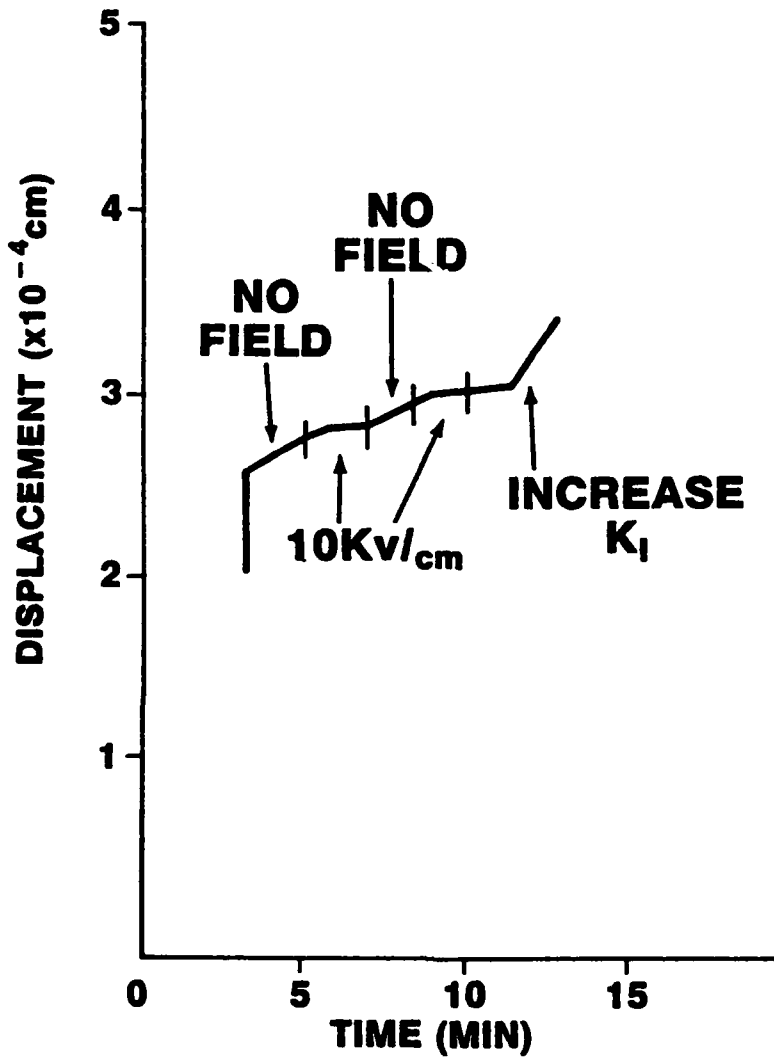

**EFFECT OF DC FIELD ON SLOW CRACK GROWTH
IN PERPENDICULAR ORIENTATION**

FIGURE 9

experiment, part of the propagating crack resides solely within the ceramic material and part intersects or propagates through the electrode layer. One might expect different crack growth characteristics in different phases. In general, the data do exhibit an overall trend to lower applied stress intensity factors indicating that the crack is able to seek out the path of lowest resistance.

The result of the application of a d.c. electric field to a specimen tested in this orientation is schematically shown in Figure 9. The figure is a trace of a deflection vs. time curve. In this type of specimen with the central web rotated 90° the application of a voltage now establishes an electric field perpendicular to the propagating crack tip. All field strengths were calculated based on the applied voltage and the individual layer thickness of the multilayer body. The generation of an electric field in this orientation serves to retard and eventually stop crack growth as shown in Figure 9. Crack propagation is initiated by the application of a load and then the voltage is applied. At this point a noticeable retardation in crack velocity is observed and within the time span of 20-30 seconds, the crack has stopped entirely. With the load still applied and the voltage removed, the crack once again begins to propagate at a velocity equal (in most cases) to the original velocity. This sequence may be repeated several times on any specimen. In order to reinitiate crack propagation with the voltage still applied, a higher applied load is required and catastrophic failure usually follows. The examination of fracture surfaces has proved inconclusive at this point as to the path that the propagating crack takes during the application and subsequent removal of applied voltages. It may well be that the portion(s) of the crack propagating within the barium titanate layers are impeded by the generation of compressive

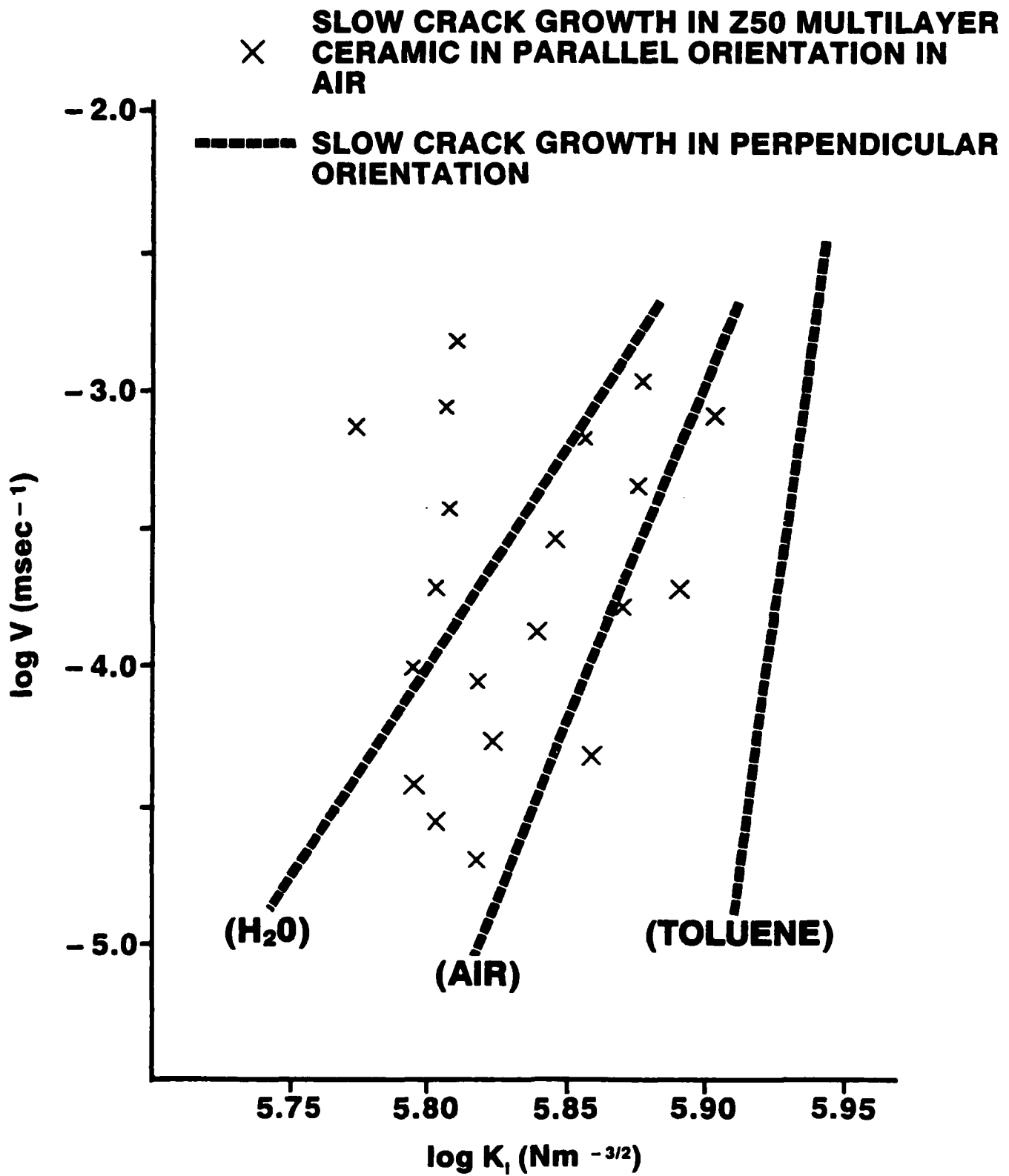

FIGURE 8: Effect of Moisture on Subcritical Crack Growth in Parallel Orientation

materials (5) as well as in bulk PZT (3,8). In the case of bulk PZT, no alteration of crack propagation was observed in either poled or unpoled material when the electrical field was parallel to the propagating crack or the polarization direction was parallel to the propagating crack.

3. Orientation Effects

Up to this point all the results have been presented in terms of one specimen orientation, namely that where the crack propagation is perpendicular to the layered structure of the capacitor specimens. The other orientation is that for which the composite specimens were fabricated. Quite different behavior is noted in this orientation.

In Figure 8 data are shown for tests conducted on parallel oriented specimens in an ambient environment. Unlike crack growth in the other orientation, the data shown in Figure 8 exhibit a tremendous amount of scatter. In general, most of the data do indeed lie at lower applied stress intensity factors than the data for the perpendicular orientation in ambient. However, the great deal of scatter prohibits the use of regression analysis to provide a meaningful interpretation of the data.

The data points for tests conducted in water and in toluene have not been included but show the same tendency as the data taken in ambient. All of the data taken for this orientation in either ambient, water or toluene exhibit large scatter and tend in some cases to overlap. This degree of scatter in the data is suggested to be a result of the anisotropic macrostructure and the testing orientation. In fact, fracture surfaces from specimens tested in this orientation usually show that at any given time during the

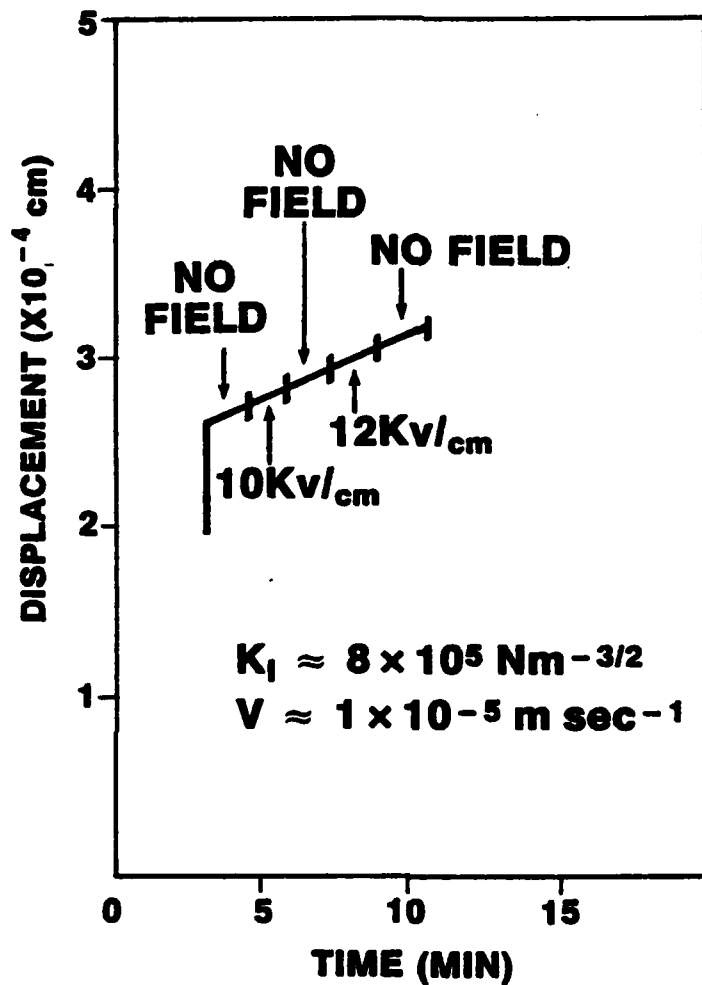

EFFECT OF DC FIELD ON SLOW CRACK GROWTH IN PARALLEL DIRECTION

FIGURE 7

and magnitude to that observed in BX and NPO type capacitor materials ⁽⁵⁾. Unlike the case of crack propagation in BX and NPO types of capacitors, no evidence of Stage II crack growth was observed indicating that this Z5U material has a sensitivity to moisture enhanced crack propagation over a wider range of applied stress and crack velocity before transport of water to the crack tip becomes rate limiting.

2. Electrical Effects

The effect of the application of a d.c. field to a multilayer specimen on the crack propagation is schematically shown in Figure 7. The figure is an actual deflection vs time trace obtained during a dead weight loading experiment. In this particular case, the applied load yielded a stress intensity of $8 \times 10^5 \text{ Nm}^{-3/2}$ and a crack velocity of $1 \times 10^{-5} \text{ m/sec}$. All electrical tests were performed with the specimens submersed in Fluorinert to prevent discharge. This represents a relatively moisture free environment and as such the crack velocity and stress intensity correspond well with data taken in a toluene environment.

The important thing to notice is that for this orientation no increase or decrease in crack velocity is seen with the application of a d.c. field. In this orientation the crack front is perpendicular to the layered structure and the application of a voltage to the specimen results in an electric field being established parallel to the propagating crack tip. It is not anticipated that a field parallel to the crack should significantly interact with and alter the propagation of that crack. This same type of behavior has been observed in other multilayer capacitor

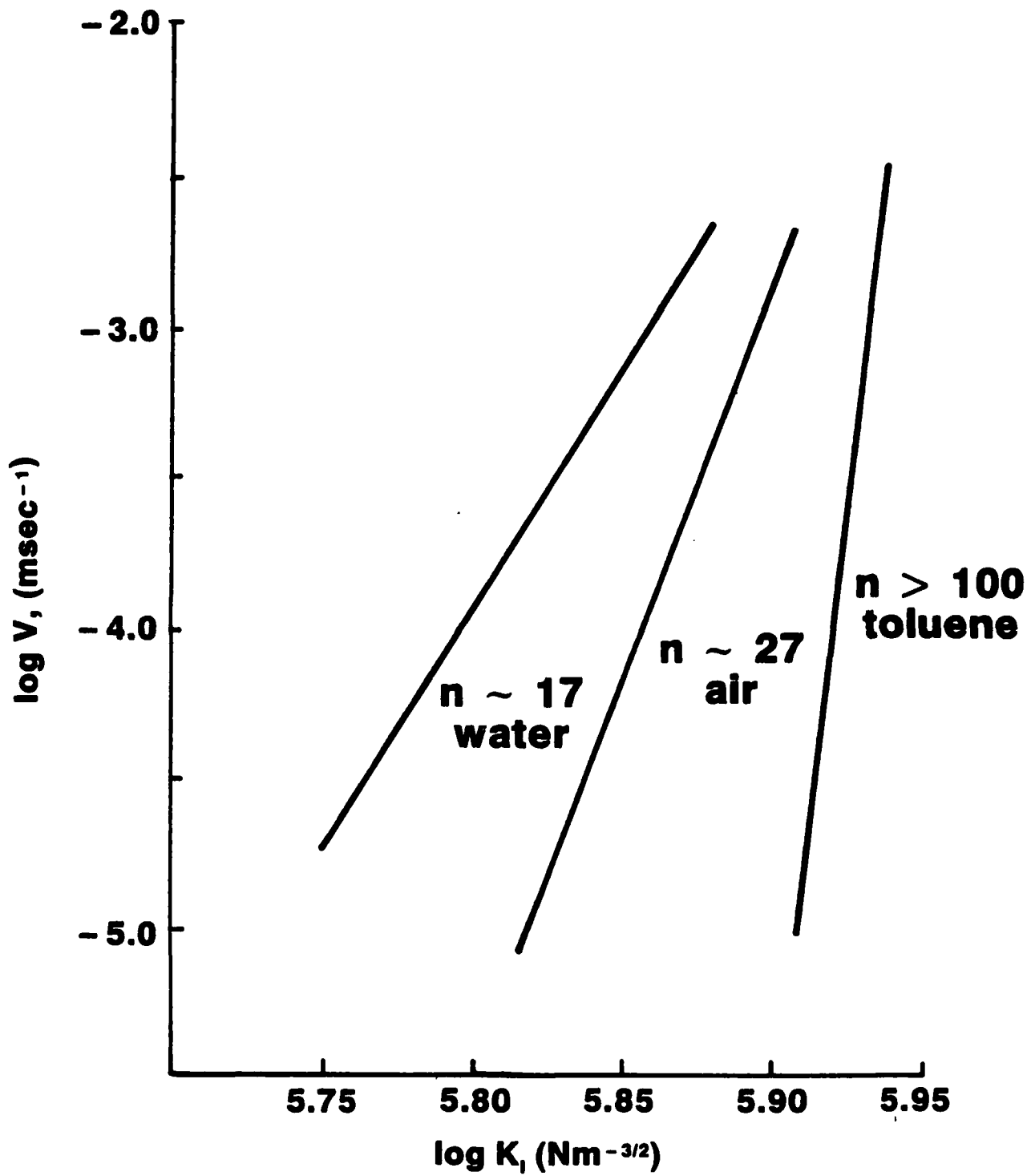

FIGURE 6: Effect of Moisture on Subcritical Crack Growth in Perpendicular Orientation

B. SUBCRITICAL CRACK GROWTH

1. Environmental Effects

Slow crack growth results for Z5U specimens tested in the perpendicular orientation (regular specimens where crack front is perpendicular to the layers) in media containing various amounts of water are shown in Figure 6. Environmental effects on slow crack growth in composite specimens will be discussed under Orientation Effects. The figure is plotted as the logarithm of the crack velocity versus the logarithm of the applied stress intensity factor. With the data plotted in this fashion, the slope, n , is a measure of the stress corrosion susceptibility of the material. A low value of n which is the case for the data taken in a water environment indicates a greater susceptibility to stress corrosion. For the sake of clarity some of the individual data points have been deleted from Figure 6. The reproducibility of the individual data points collected from a single specimen as well as sample to sample reproducibility was outstanding. Such reproducibility can either be a result of very homogeneous material or an averaging effect since the crack front at any given time is intersecting 7-8 layers of material. In the other orientation discussed later, a marked lack of reproducibility is observed.

The overall significance of the data shown in Figure 6 is that like most other ceramic materials this multilayer capacitor material is very susceptible to moisture enhanced slow crack growth. The data taken in a toluene environment with a slope in excess of 100 is probably indicative of Stage III crack propagation while the other data are probably representative of Stage I crack propagation or stress corrosion. The susceptibility of this material to moisture enhanced slow crack growth is similar in nature and

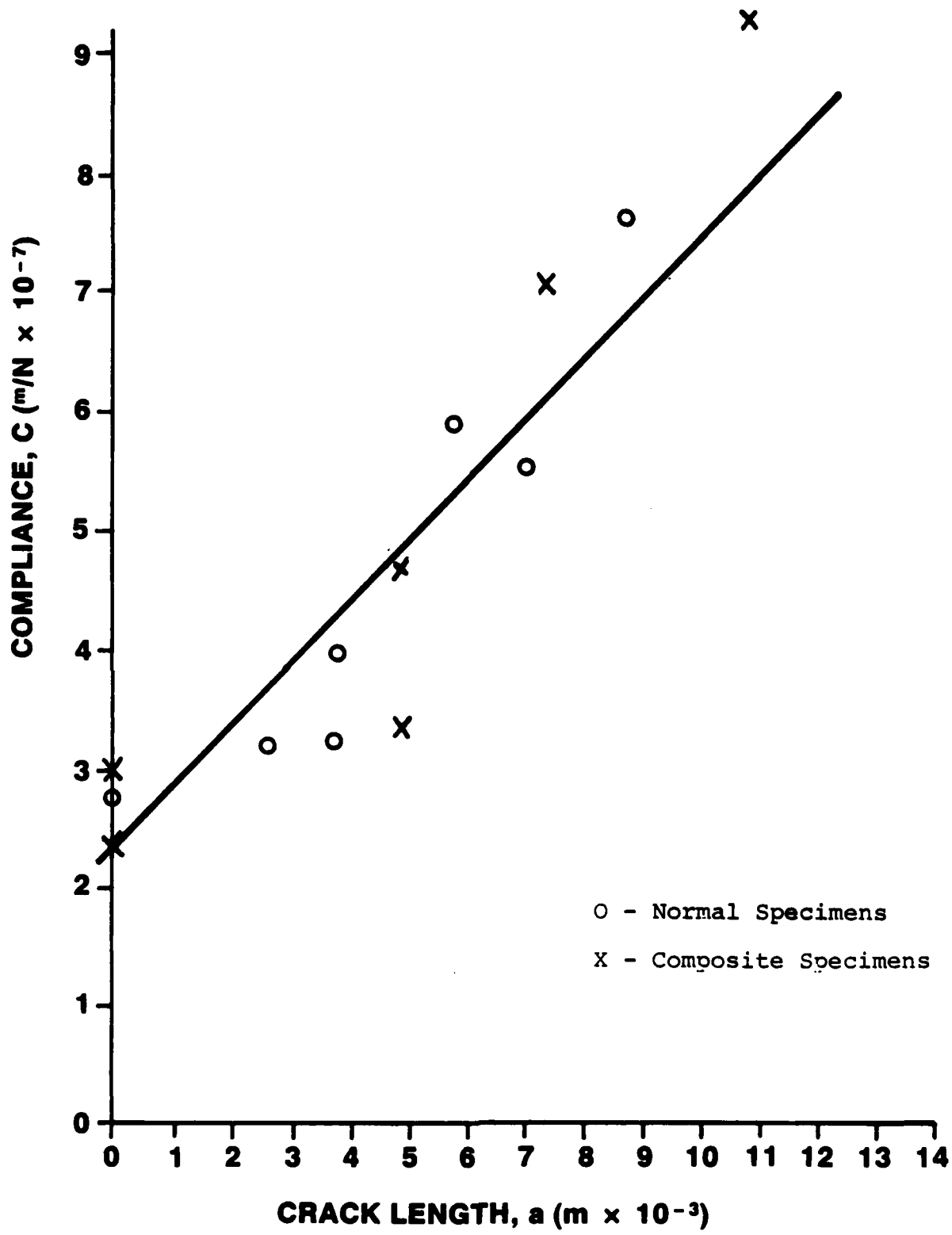

FIGURE 5: Compliance Measurements of E5U Multilayer Dielectrics

III. RESULTS AND DISCUSSION

A. COMPLIANCE MEASUREMENTS

Since the elastic analysis of a DT specimen is based upon the condition that the compliance of the specimen is a linear function of crack length, the compliances of a number of regular and composite specimens were measured as a function of crack length by artificially introducing cracks of known length with a very thin diamond blade. The results are shown in Figure 5. Due to the fact that the specimens had varying thicknesses as a result of grinding them flat, the results shown in Figure 5 are normalized by the thickness cubed, t^3 , from the theoretical compliance of a DT specimen ⁽⁷⁾. The slope of the data shown in Figure 5 was used to calculate the crack velocity according to Equation 2.

It's interesting to note that the compliances shown for the two differently constructed specimens in Figure 5 are equal. The silver-filled epoxy used in this investigation is the same type used previously in fracture studies of bulk PZT ⁽³⁾. In that study, it was found that the compliances of regular specimens and composite specimens were virtually identical. The data shown in Figure 5 indicate that the compliances of the two different types of specimens are nearly equal and there appears to be no anisotropic microstructural effects.

Preliminary compliance measurements have been performed on multi-layer monolithic PZT bodies and a different type of phenomenon has been observed. The PZT bodies are originally fabricated large enough such that DT specimens of both orientations can be obtained without having to fabricate composite specimens. In this case, indications are that the specimens are more compliant when the layered structure is parallel to the thickness of the specimen.

specimen. The section was rotated 90° and epoxied back in as the central web. This provided the necessary configuration for propagating a crack parallel to the layers. The procedure for precracking the specimen, the method of slow crack growth evaluation and the procedure for measuring the fracture toughness were identical to those discussed previously.

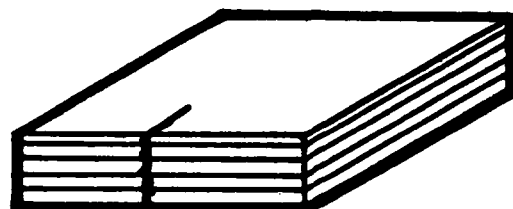

PERPENDICULAR ORIENTATION

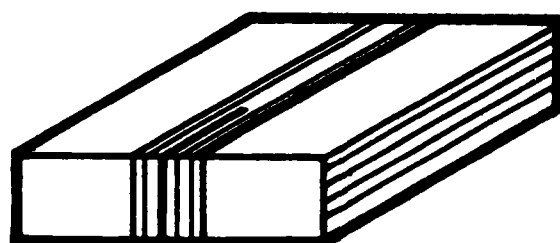

PARALLEL ORIENTATION

FIGURE 4: Crack Orientations with Respect to Multilayer Orientation

C. MATERIAL AND TESTING ENVIRONMENTS

The barium titanate multilayer capacitor bodies used in the study were a standard Z5U composition supplied by Sprague Electric. The specimens were quite a bit oversized compared to normal capacitors and exhibited some degree of warpage in the as-received state. Some surface grinding had to be performed to achieve adequately flat and parallel specimens. The specimens as-received contained 7-8 individual electroded layers.

Samples were tested in a variety of environments selected for varying moisture content as well as in various electrical environments. Specimens were tested in ambient conditions (25°C and 45% R.H.), submersed in water and submersed in toluene. Electrical environments consisted primarily of applied d.c. fields of various field strengths. The application of electric fields was accomplished by painting stripes of conducting paint on the specimens and attaching leads.

D. COMPOSITE SPECIMEN FABRICATION

The macrostructure of multilayer ceramic bodies such as the ones considered in this investigation is highly anisotropic. As such, the electrical and mechanical properties are usually anisotropic. As shown in Figure 4, there are two crack orientations with respect to the macrostructure that must be considered. The situation where the crack front is perpendicular to the multilayer structure (the crack cuts across the layers) represents the normal testing that was performed on the as-received plates. In order to achieve the other orientation, it was necessary to fabricate composite specimens. This was accomplished by cutting a section from the edge of the specimen or from the middle of the specimen. The width of this section was approximately equal to the thickness of the overall

FRACTURE TOUGHNESS OF Z5U MULTILAYER CERAMICS AS A FUNCTION OF ORIENTATION

PERPENDICULAR		PARALLEL	
SAMPLE #	$K_{Ic}(Nm^{-3/2} \times 10^{-5})$	SAMPLE #	$K_{Ic}(Nm^{-3/2} \times 10^{-5})$
2	8.8	37	7.4
7	7.4	39	8.7
10	9.1	40	6.8
11	9.3	41	7.9
14	8.9	45	8.1
16	9.5	49	7.3
17	9.2	54	7.2
18	8.9	55	7.8

AVERAGE = 8.9 ± 0.6



AVERAGE = 7.6 ± 0.6



IV. CONCLUSIONS

Based on the results obtained thus far, the following conclusions may be drawn.

- o Slow crack growth is enhanced in Z5U dielectric capacitor materials when the material is subjected to moisture containing environments.
- o Compliance of fracture mechanics specimens does not appear to be effected by orientation of multilayer structure.
- o Fracture toughness is higher when crack is oriented perpendicular to the multilayer structure.
- o Application of d.c. fields parallel to the crack front does not significantly effect crack growth rates.
- o Application of d.c. fields perpendicular to the crack point retards crack propagation possibly due to electrostriction.

REFERENCES

1. E. B. Thornley, Proc. Symp. Capacitor Tech., Appl. and Reliab., Huntsville, Ala., NASA, (24, 25 Feb. 1981) p. 93.
2. R. C. Pohanka, S. W. Freiman and R. W. Rice, Ferroelectrics, 28, 337 (1980).
3. J. G. Bruce, W. W. Gerberich and B. G. Koepke, in Fracture Mechanics of Ceramics, Vol 4, ed. by R. C. Bradt, D. P. H. Hasselman and F. F. Lange, Plenum Press, New York, (1978) p. 687.
4. M. J. Cozzolino and G. J. Ewell, IEEE Trans. on Components, Hybrids and Manufacturing Technology, Vol. CHMT-3, No. 2 (1980) p. 250.
5. K. A. Esaklul, K. D. McHenry, B. G. Koepke and H. Vora, to be published. Based on work carried out under contract to Hughes Aircraft Co.
6. A. G. Evans, J. Mater. Sci., 7, 1137 (1972)
7. D. P. Williams and A. G. Evans, J. Testing and Eval, 1, 264 (1973).
8. K. D. McHenry and B. G. Koepke, in Fracture Mechanics of Ceramics, Vol. 5, R. C. Bradt, A. G. Evans, D.P.H. Hasselman and F. F. Lange, Ed., Plenum Press, New York (1983), p. 337

END

FILMED

10-85

DTIC