

AD-A159 647

DEVELOPMENT AND DESIGN OF AN ADVANCED DIRECTIONAL SHEAR  
(U) UNIVERSITY COLL LONDON (ENGLAND) J ROBIN ET AL.  
SEP 85 DAJA45-85-C-0008

1/1

UNCLASSIFIED

F/G 4/2

NI

END
PAID
11-85
11

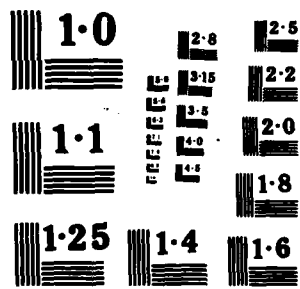

①

DEVELOPMENT AND DESIGN

OF

AN ADVANCED DIRECTIONAL SHEAR CELL

INTERIM TECHNICAL REPORT

by

J. ROBIN P. ARTHUR

September 1985

AD-A159 647

United States Army

European Research Office of the U.S. Army

London, England

Contract No. DAJA 45-85-C-0006

University College London

DTIC FILE COPY

DTIC  
ELECTE  
SEP 30 1985

*[Handwritten signature]*  
E

This document has been approved  
for public release and sale; its  
distribution is unlimited.

85 09 30 112

Abstract

A prototype shear apparatus of the type known as a Directional Shear Cell has been designed. The purpose of the prototype is the shearing of undisturbed soil samples at stress levels normal in engineering practice with completely controlled rotation of principal stress directions through  $0^\circ$  to  $360^\circ$  <sup>deg</sup> in the plane of strain. Factors affecting the design are listed and discussed to explain the form of the resulting design. The design is presented in some detail, but without working drawings. Testing will be automatic; stress paths, including undrained and cyclic paths, will be imposed under computer control and boundary strains will be processed automatically. In addition it will be possible to determine strain distributions in samples by either radiography or photography.

Accession For	
NTIS	GRA&I
DTIC	TAB
Unannounced	
Justification	
<i>form SDP</i>	
By	
Distribution/	
Availability Codes	
Dist	Avail and/or Special
<i>A-1</i>	

DDC  
QUALITY  
INSPECTED  
1

Keywords

Design, Laboratory Shear,

Undisturbed Soil Samples,

Stress Path, Principal Stress Direction Control,

Cyclic Tests, Computer Control,

Alternative Strain Measurements.

## Table of Contents

	<u>Page</u>
1. Introduction	1
2. Intended use and choice of type of apparatus	2
3. Brief Description of the original Directional Shear Cell	3
4. Design philosophy and method	4
5. Materials	5
6. Daisy chain shear sheets	6
7. Sample size	8
8. Null method of undrained testing	9
9. Avoidance of apparatus hysteresis in cyclic loading	10
10. Automatic control of normal pressure bag and shear sheet alignment	10
11. Automatic boundary strain measurement	11
12. Stress path control	12
13. Design performance	13
14. Potential difficulties	15
15. Further developments	15
16. Stressing of components	15

Table of Contents (contd.)

17.	Ergonomics	16
18.	Design drawings	16
19.	Citations	17

List of Illustrations

1. Applied Stress Components.
2. Cross-section of original D.S.C.
3. The principle of the daisy chain Shear Sheets.
4. Stress-Strain Data Sustained using daisy chain Shear Sheets.
5. New Method of Applying Normal Stress with Self-Alignment.
6. Shear Sheet Alignment System.
7. Range of Deformed Sample Shapes.
8. Layout for Shear Sheets and Actuators.
9. Plan view from plane just above top of sample.
10. Elevation detail of drives for guide roller carriages.
11. Centre line vertical section.

1. Introduction

This report summarises the work of a group of six who contributed their expertise by regular discussions, experiment and design. The six people involved were:

Robin Arthur	Treve Dunstan	John Pulsford
Eric Cutler	John Ford	Robin Wong

They are all members of the Geotechnical Group in the Civil Engineering Department at University College London (UCL).

The objectives set out in Section C-1 of the contract have been achieved although not always in the way originally envisaged. Item by item the results are summarised as follows:

- (a) A null method of undrained testing has been investigated and substituted for the enclosure. This will have no restricting effects and the apparatus will be much easier to operate.
- (b) In view of possible limitation on normal stresses 0-400kPa is recommended as a generous practical range for shear stress application.
- (c) Cyclic capability (0-360°) will be provided.
- (d) Experiments have shown that it is advisable to standardise on a single sample size 100mm x 100mm x 75mm.

The scope of work in Section C-1 of the contract is covered in the various sections of the report that follows:

C-1 Scope of Work

Corresponding Section of  
this Report

(a)	4
(b)	10
(c)	5 (Figure 4)
(d)	5-16 inclusive Figure 3-11 inclusive

2. Intended Use and Choice of Type of Apparatus

This prototype design has been commissioned by the U.S. Corps of Engineers Waterways Experimental Station with the aim of eventually routinely testing undisturbed samples from the field under stress paths including controlled rotation of the principal stress directions. The commission went to the Geotechnical Group at U.C.L. England essentially because the Directional Shear Cell (D.S.C.), which was developed for basic research there, had a practicable cubical sample shape as opposed to that of the Hollow Cylinder Apparatus. Although all the work carried out at U.C.L. has been on sand the Geotechnical Group at M.I.T. had bought a D.S.C. and used it in basic research on resedimented Boston Blue Clay. Thus it was known that the D.S.C. could be used for high quality shear tests on this most important soil type.

The developed versions of the D.S.C. had a serious disadvantage in being limited to testing at what in geotechnical terms are very low stress levels. A new design of D.S.C. which overcomes this problem, is currently under development at U.C.L. The commissioned prototype is a further advance in requiring in addition completely automated testing (including cyclic tests) and capability to rotate principal stress directions through  $360^\circ$  as opposed to the  $90^\circ$  limit of existing types.

3. Brief Description of the Original Directional Shear Cell

Detailed description of the fully developed low stress D.S.C. is offered elsewhere [1] and only a brief summary is given here. The Cell is a flexible boundary stress controlled device imposing essentially uniform boundary stresses. The principal stress direction can be controlled by varying the normal stresses  $\sigma_a$  and  $\sigma_b$  together with the shear stresses  $\tau_a$  and  $\tau_b$ . These stresses act on four faces of a cubical sample which is constrained between end platens on the other two faces. Figure 1a illustrates the underlying principle while Figure 1b shows Mohr's circles representing three states of stress. Hence any major principal stress direction can be achieved between plane strain compression (1) through maximum shear (2) to extension (3) by changing the relative magnitudes of normal and shear stresses.

Figure 2 illustrates the method used to apply normal and shear stresses to the four vertical faces of the cubical test specimen (100mm cube). The soil sample in its rubber membrane is in direct contact with the shear sheets. The shear sheets consist of flexible elastic rubber pulling strips attached to thin latex sheet which bonds under pressure to the sample membrane. These elastic strips can stretch up to 300% of their original length and distribute the shear stress evenly onto the sample. Improved traction is provided on the inside of the sample membrane by a layer of sand glued to the membrane. The ends of the shear sheets are attached via inextensible sheets to hydraulic piston assemblies which apply the desired shear forces. Two sets of reinforced rubber pressure bags of concertina form transmit  $\sigma_a$  and  $\sigma_b$  through the shear sheets onto the sample. A glass platen allows the deformation of the entire top face of the sample to be observed directly. The strain distributions of the sample are calculated from the displacements of regularly spaced markers such as those shown in Figure 2. If radiography is used these markers are in the central plane of strain in the sample, photography can be used as an alternative if the markers are on the sample membrane.

#### 4. Design Philosophy and Method

The design was evolved in a process involving experiment and wide ranging discussion. The clients

have been extremely constructive and helpful on each occasion on which it was felt necessary to consult with them. The designers have held regular weekly discussions with the researchers working with existing D.S.C. equipment and also the workshop technicians who will make any new prototype. These "multi-channel" discussions have been greatly appreciated by the designers; many features of the design have been influenced by them.

The aim throughout has been to produce an apparatus which would be easy to work with. Every aspect has been considered in this light starting from the preparation and maintenance of the apparatus, continuing through setting up the soil sample, and of course, running the test itself.

It is intended that the weekly meetings will be a feature of the next phase of the work, the manufacture and development testing of the prototype.

5. Materials

In accordance with the clients wishes the possibility of using silicon rubber for manufacturing pressure bags and sheets was investigated; there is an obvious advantage in that silicon rubber is readily moulded. However, it proved impossible to achieve adhesion under pressure between silicon rubber surfaces

or silicon rubber/natural rubber interfaces. This adhesion is essential for the best distribution of surface shear to sample faces so the use of silicon rubber was abandoned.

Furthermore, light strong sail cloth has been found to bond to ordinary latex rubber extremely well and provides the basis for a dramatic increase in the stress level of D.S.C. tests. Cutting the sail cloth in the intricate shapes required can be done relatively easily with a very light "electronic" soldering iron.

6. Daisy Chain Shear Sheets

This new design of shear sheets which is under development at U.C.L. is the essential feature for achieving tests at higher stress levels. As in the original shear sheets the shear stress is distributed through the sample membrane by a thin shear sleeve of latex rubber which adheres totally to the membrane when under normal pressure. Thin strips of rubberised sail cloth are glued to the outer surface of this sleeve replacing the unreinforced stretching rubber strips shown in Figure 2. Lubrication is used in the same way as with the old shear sheets, but the introduction of the stretching element which ensures the uniformity of the applied shear is entirely different and is illustrated for one typical strip in Figure 3. Each strip now embodies a series of stretching rubber elements of

increasing thickness (and therefore stiffness) whilst the reinforced sail cloth is continuous through all of them but glued to each with sufficient slack to allow pre-determined stretch of each element. As these stretching elements are no longer subjected to the normal pressures there will be no stress hysteresis effects due to the elements during cyclic loading. Data obtained using daisy chain sheets at U.C.L. under this contract is shown in Figure 4 and compared with data on the same sand in the fully developed D.S.C. The results are encouraging especially in view of some of the clumsiness of the U.C.L. apparatus used for this trial; big improvements in control of the shear sheets have been made and further tests will be carried out soon. Present results are held to be sufficiently good to go ahead with the new prototype even without the further improvements which are probable.

Several innovative changes are proposed for the shear sheets designed for the prototype. The most obvious is that the actuating pressure cylinders used to tension the shear sheets will not move when the shear sheet orientation has to be changed to accommodate deformation. The re-orientation of the shear sheets will be accomplished by guide rollers stationed nearer the sample. The second follows from experience with the first daisy-chain shear sheet suggesting that a stage system with less severe stiffness changes will be much

easier to handle. Accordingly stages giving a maximum applied shear stress of 400 kPa have been adopted; this change almost halves the width of the shear sheets pulling on one face with consequent improvements in geometry and a generally more compact apparatus. The pre-determined stretch of some stages of the chain may be increased by 50% and 100% to achieve this result and the latex rubber sheet has been tested to show that it is feasible. This change reduces the essential stiffness jumps which are inherent in daisy-chain type sheets.

7. Sample Size

The existing sample size 100mm cube (4 ins.) is not appropriate for undisturbed samples. In order to assess the effects of sample size a prismatic sample 75mm x 75mm (3" x 3") has been used with shear sheets of the old type specially made to match. In order to save time a rig for the 100mm x 100mm section was used; it has proved difficult to adapt and reliable results are only just becoming available. These results are not encouraging and it is quite likely that 100mm x 100mm represents the smallest practical plane of strain section.

In view of the urgency of deciding on sample size and the lack of experience in testing samples smaller than 100mm cube we advise that Dr. John Peters'

suggestion of 100mm x 100mm x 75mm be adopted. This size is compatible with testing undisturbed samples from 125mm (5 ins.) dia tubes. The decreased thickness is not thought to be significant although the evidence for this at higher stress levels relies on earlier work by Arthur and Dallili [2]. At low stress levels it has been demonstrated at U.C.L. that present lubrication techniques using a polytetra fluorethylene powder filling in high viscosity silicon grease is extremely effective. Recent Japanese work follows these techniques but appears to have come up with an improved grease formulation; this will be investigated.

8. The Null Method for Undrained Testing

In the null method of undrained testing the sample is saturated or very close to saturated and sealed so no water flow in or out can occur. An internal pore water pressure transducer or a "hard" external link to an external transducer is used to monitor any small incremental change of the internal pore water pressure from zero. Then the applied mean total stress is adjusted to return the pore water pressure to zero; in an existing U.C.L. system for the fully developed D.S.C. this is done under computer control.

This method will be adopted for the new prototype D.S.C. because in any sample tested in a D.S.C. changes

in internal pore water pressure will cause changes in sample volume by expanding the sample membrane along edges. Special low air entry porous tips and associated hard systems have been developed at M.I.T. for use in D.S.C. samples, these are recommended, but do not form part of the second stage contract which is proposed[3]. This facility can easily be added when needed. The software for computer controlled undrained tests will be developed as part of the second stage of this contract.

9. Avoidance of Apparatus Hysteresis in Cyclic Loading

The stretching elements of the new shear sheets are not held during unloading by transverse normal pressure. Experiments with the U.C.L. high stress prototype suggest that apparatus hysteresis will be low provided gas is used as the pressurising agent in the bellofram cylinders which will provide all the loading systems. Accordingly gas will be adopted.

10. Automatic Control of Normal Pressure Bag Face and Shear Sheet Alignment

These automatic alignments are an entirely new feature of this prototype design. A model which partially simulates the mechanism for aligning the normal pressure bag face has been built and tested, but the performance cannot be fully evaluated before the new prototype apparatus is available for testing. A closed inextensible reinforced pressure bag is used which is

bonded at the back to the front of the backing plate. It is water filled so that its dimensions will change a negligible amount under pressure. Two balanced bellofram cylinders apply load through roller bearings to the rear of the backing plate. The backing plate is free to translate forwards and backwards whilst self-aligning with the face of the sample. Figure 5 illustrates this system.

Make and break contact position indicators operating to  $\pm 0.025\text{mm}$  will control stepper motors driving the guide rollers for the shear sheets. Figure 6 illustrates this system. Each position indicator takes the form of a rigid arm a thin section of which is trapped between the normal pressure bag and the shear sheets. It is this section which controls the movement of the position of the indicator; the ends of the normal pressure backing plates are relieved over appropriate areas to ensure that the indicator is not restrained in the horizontal plane.

#### 11. Automatic Boundary Strain Measurement

Strain control cannot be achieved in this apparatus which is essentially stress controlled. However, the automatic alignment system for the shear sheets can and will be utilised to provide automatic boundary strain measurements. Stress-strain data output will be a matter of software development. It is intended to base the calculations on stepper motor pulses.

In addition provision has been made for placing an X-ray cassette in the optimum position just below the base plate to allow high quality radiographs to be taking for computing internal strain distributions in the central planes of the sample. It will also be possible to take photographs of markers on the top of the sample through the top plate. Data from strain distributions achieved by both techniques in the fully developed D.S.C. have recently been described[4].

## 12. Stress Path Control

The applied boundary stresses acting in the plane of strain are  $\sigma_a$ ,  $\sigma_b$ ,  $\pm\tau_a$ ,  $\pm\tau_b$ , in addition the intermediate principal stress  $\sigma_2$  may be controlled within certain limit of  $b$ , where  $b = \frac{\sigma_2 - \sigma_3}{\sigma_1 - \sigma_3}$ . As all these components must be controlled independently five stepper motor control valves are essential and as the direction of  $\tau_a$  and  $\tau_b$  can be reversed simple flow switching valves are needed for each. Experience has already been gained at University College London in operating D.S.Cs. under computer control with this type of valve. No problems are anticipated; it should be noted that a sensitive system for detecting very small pore water pressure changes in the samples is needed in addition to operate the null method of undrained testing. A compressor supplying pressurised air to operate the valves will of course be needed at W.E.S. Computer software in BASIC will be supplied by U.C.L. for stress path control with a capability for cyclic tests.

13. Design Performance

(i) Stresses

Choosing the parameters for attainable performance is extremely difficult in the case of complex prototype apparatuses. It was originally suggested that maximum normal stress should be in the region 200-150 psi (1400 - 950kPa) and maximum shear stress 70 psi (500kPa). If a maximum major principal effective stress of 100 psi (700kPa) is assumed at failure, the requirement for a maximum shear stress of 70 psi (500kPa) is seen to be double that likely to be needed by considering the example of a rather strong soil with strength parameters  $C' = 0$  and  $\phi' = 35^\circ$ . As a reduction of the required maximum shear stress to 400kPa led to very real improvements in shear sheets characteristics this is the limit designed for. In the case of the normal pressure bags there is no easy way of predicting limiting pressure (stress) before prototype testing. We are confident of achieving at least 100 psi (700 kPa) reliably and hope to do considerably better.

(ii) Strains

Figure 7 illustrates the extremes of distorted shapes that must be allowed for in designing an apparatus of this type. The need to achieve automatic alignment of both normal pressure bags and shear sheets has largely dictated the geometry of the proposed design. For

instance to allow for alignment of the shear sheets in cyclic tests with principal stress direction rotations up to  $360^{\circ}$  it has been necessary to site the normal pressure bag actuating cylinders above and below the apparatus. Maximum achievable homogeneous shear strain has been set at 30% when full boundary shear stress is applied and 20% when no boundary shear stress is applied. This distinction is made because of the inability of the normal pressure bags to change length to follow changing lengths of sample force. Again prototype tests are essential to evaluate the performance of the new form of pressure bag.

(iii) Rates of Strain (and Cycling)

All existing D.S.Cs. have been operated with increments applied extremely slowly. It may well be that this apparatus will have much better characteristics than the existing apparatuses, indeed limited experiments with our existing high stress D.S.C. suggest that apparatus hysteresis effects will be minimal at low strain rates. Nevertheless the effects of the viscosity of lubricating grease appear to be a factor in cyclic tests with a period of less than 20 seconds. There is no reason to suppose that this limitation will be changed for the new design. Accordingly computer software will be simple, based on the assumption that only low rates of cycling are attainable in practice.

14. Potential Difficulties

The design is essentially new and breaks new ground on the automatic alignment of both normal pressure bags and shear sheets not to mention the increase in rotation of principal stress directions from  $90^{\circ}$  to  $360^{\circ}$ . The self alignment of the normal pressure bags may be affected by the moment induced by a residual degree of friction on the lubricated front faces of these bags. The stiffness jumps on the shear sheets may have to be adjusted to achieve the best results.

15. Further Developments

The virtual inability of the normal pressure bags to follow dimensional changes in the faces of the sample limits the strain which may be imposed under loadings involving little or no boundary shear stress. This defect has been overcome in a simple plane strain device designed by Arthur and Dunstan [5]. There is a possibility that similar improvement can be achieved for the D.S.C., but it will be difficult, costly and probably time consuming; it is not considered a realistic goal for the present prototype design.

16. Stressing of components

In general rather wide margins of safety have been adopted so that all actuating cylinders will, at least nominally, be within the working stress range when

operating at more than 3500kPa (500 psi). However, it must be noted that welding will be used in constructing these cylinders, and it is intended to carry out pressure tests to 2100kPa (300 psi). The effects of applied moments have been carefully considered and held to acceptable levels; this has complicated the design for the drives for the guide roller carriages.

17. Ergonomics

The design is by users for users, simplicity of operation has been aimed at throughout. It will always be possible to stand, bend slightly forward and look directly down at the sample. The shear sheets will be easy to remove for lubrication and sleeve cleaning. The sample can be placed before the normal pressure bags and backing plates are positioned around the sample. Light signals will ease the initial setting of the contact position indicators. Every effort will be made to make the software for stress path control both versatile and user friendly.

18. Design Drawings

The drawings presented have been kept as simple as possible to convey the main features of the design. The overall shape of the apparatus is cruciform; this is dictated by the length of the shear sheets. Figure 8 indicates the arrangements for stretching the shear sheets and shows this basic form. Figures 9, 10 and 11

are full scale design drawings which cover the essentials of the design. Parts are labelled and displayed on a key for these figures.

19. Citations

1. Arthur, J.R.F., Bekenstein, S., Germaine, J.T. and Ladd, C.C. 1981. "Stress Path Tests with Controlled Rotation of Principal Stress Directions" Laboratory Shear Strength of Soil, STP 740, ASTM pp.516-540.
2. Arthur, J.R.F. and Dallili, A., "On the Lubrication of Rubber Surfaces", Geotechnique Vol.29. 1. 96-98.
3. Germaine,, J.T., 1982. "The Development of the D.S.C. for Measuring Cross-Anisotropic Clay Properties" Sc.D. Thesis M.I.T.
4. Wong, R.K.S. & Arthur, J.R.F., 1985. "Determinations & Uses of Strain Distributions in Sand Samples". Geotech. Testing Journ. Vol.8. 3. 101-110.
5. Arthur, J.R.F., Dunstan, T. and G.G. Enstad, 1985. "Determination of the Flow Function by Means of a Cubic Plane Strain Tester". International Journal of Bulk Solids, July '85.

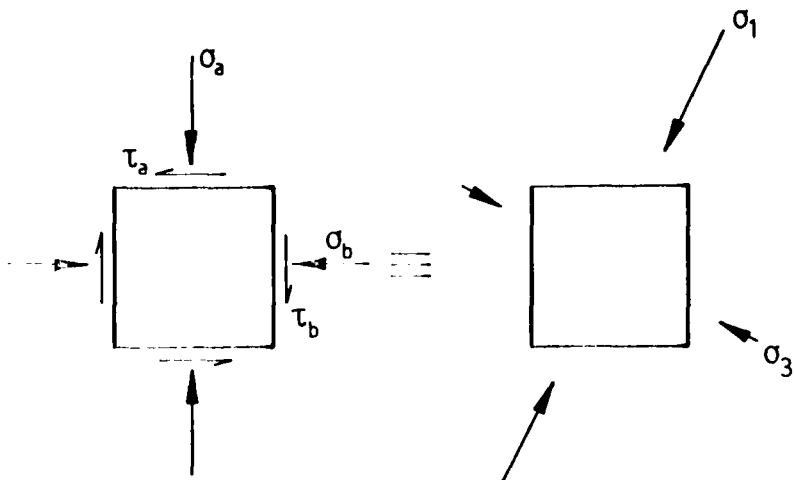

(a)

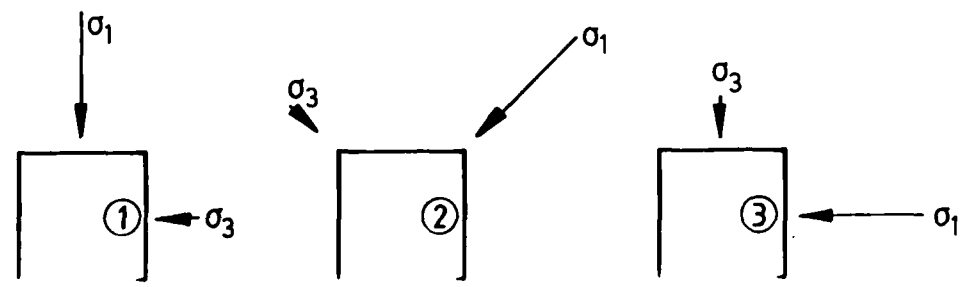
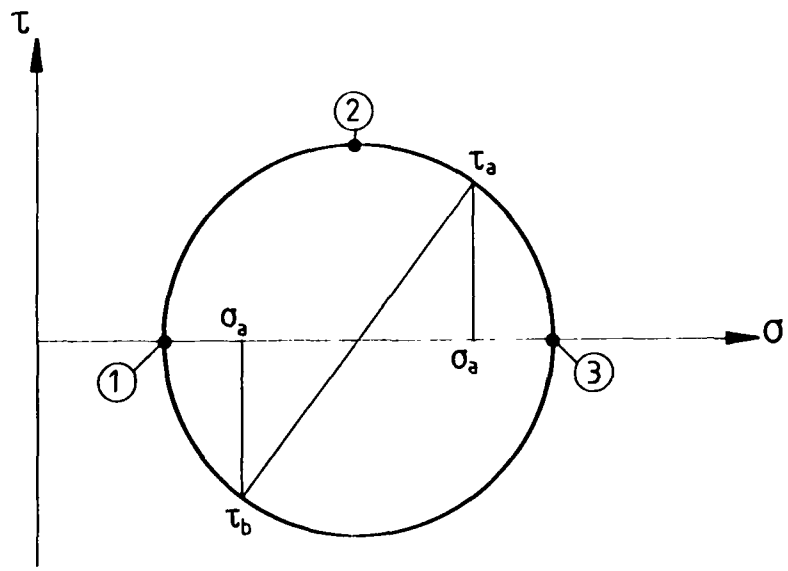

(b)

Figure 1

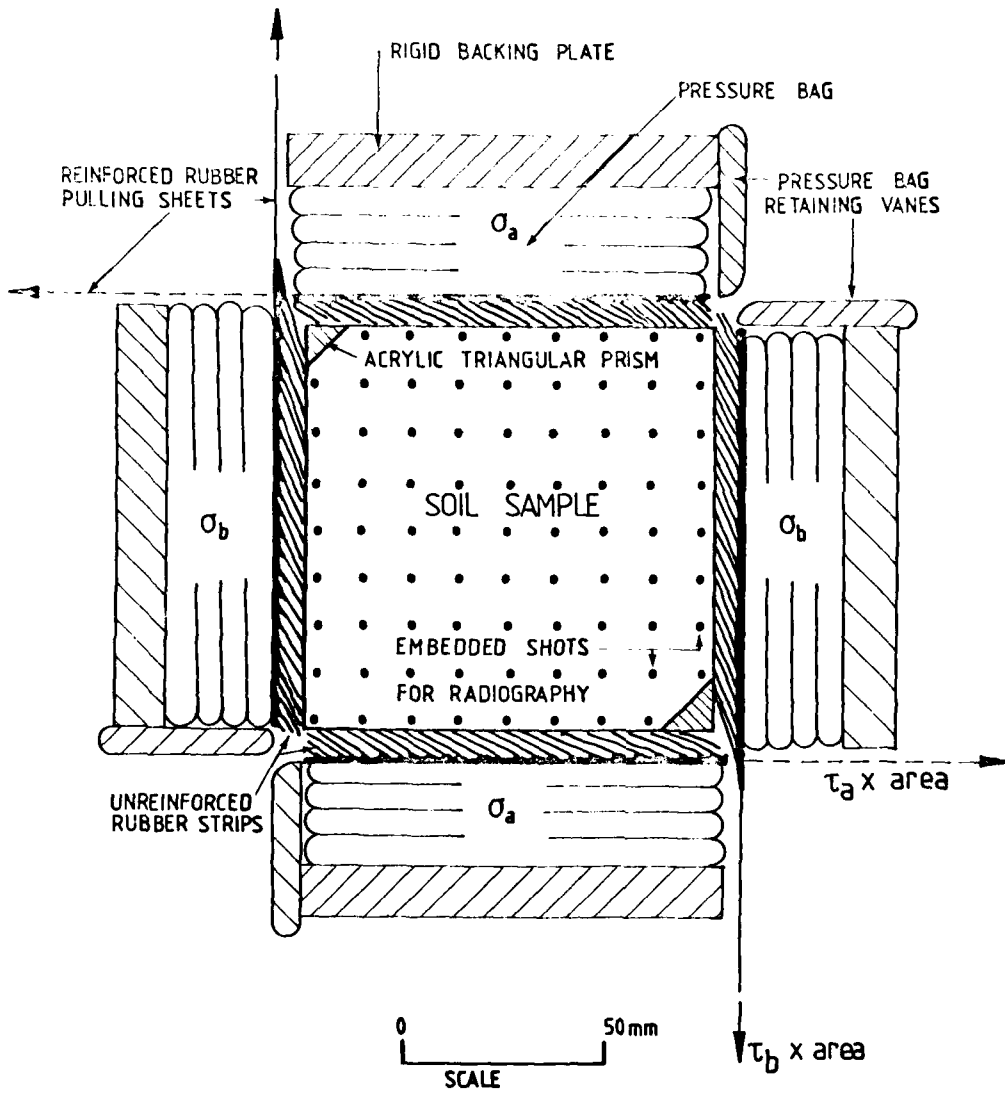
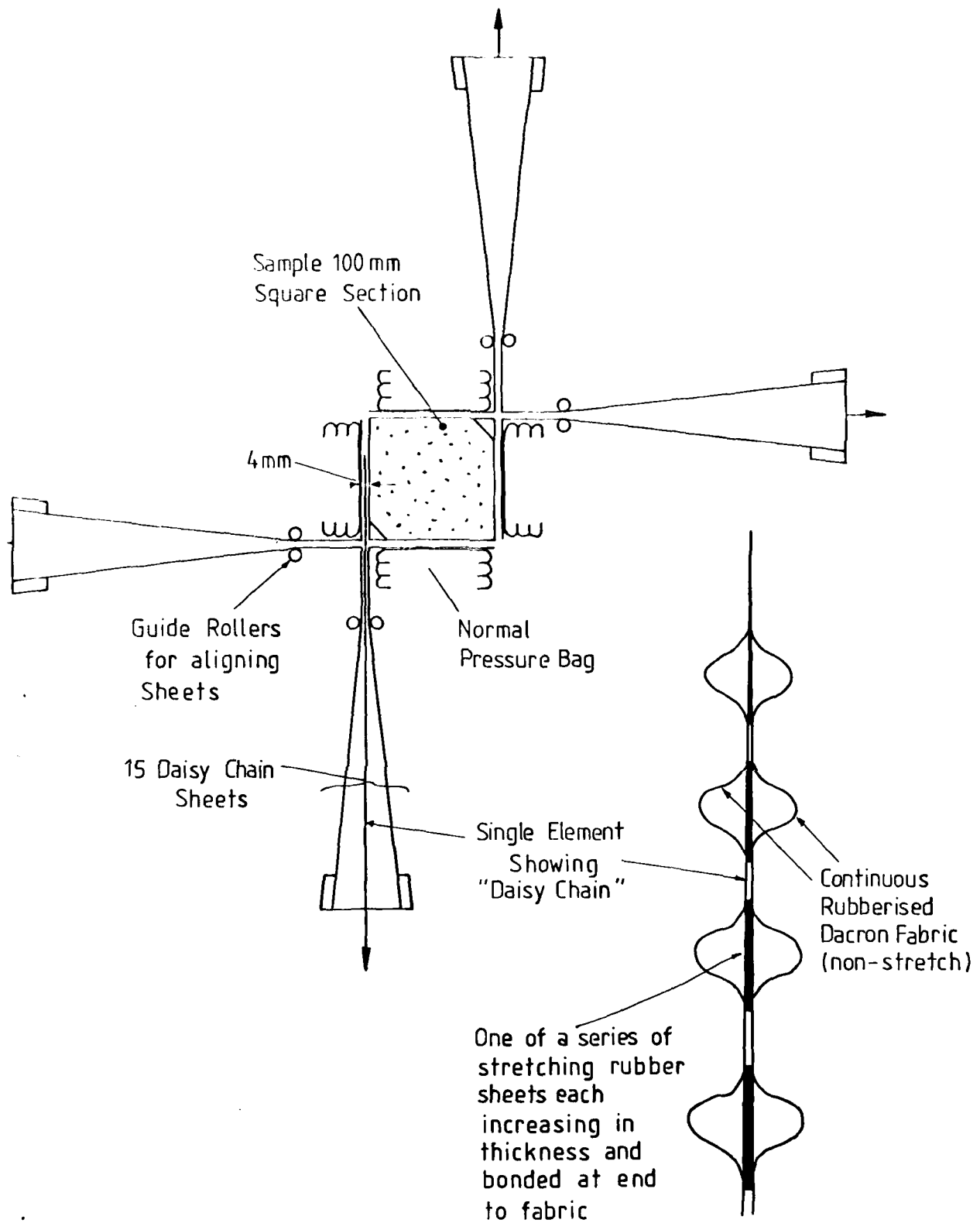

Figure 2



Principle of New Wide Stress Range Shear Sheets

Figure 3

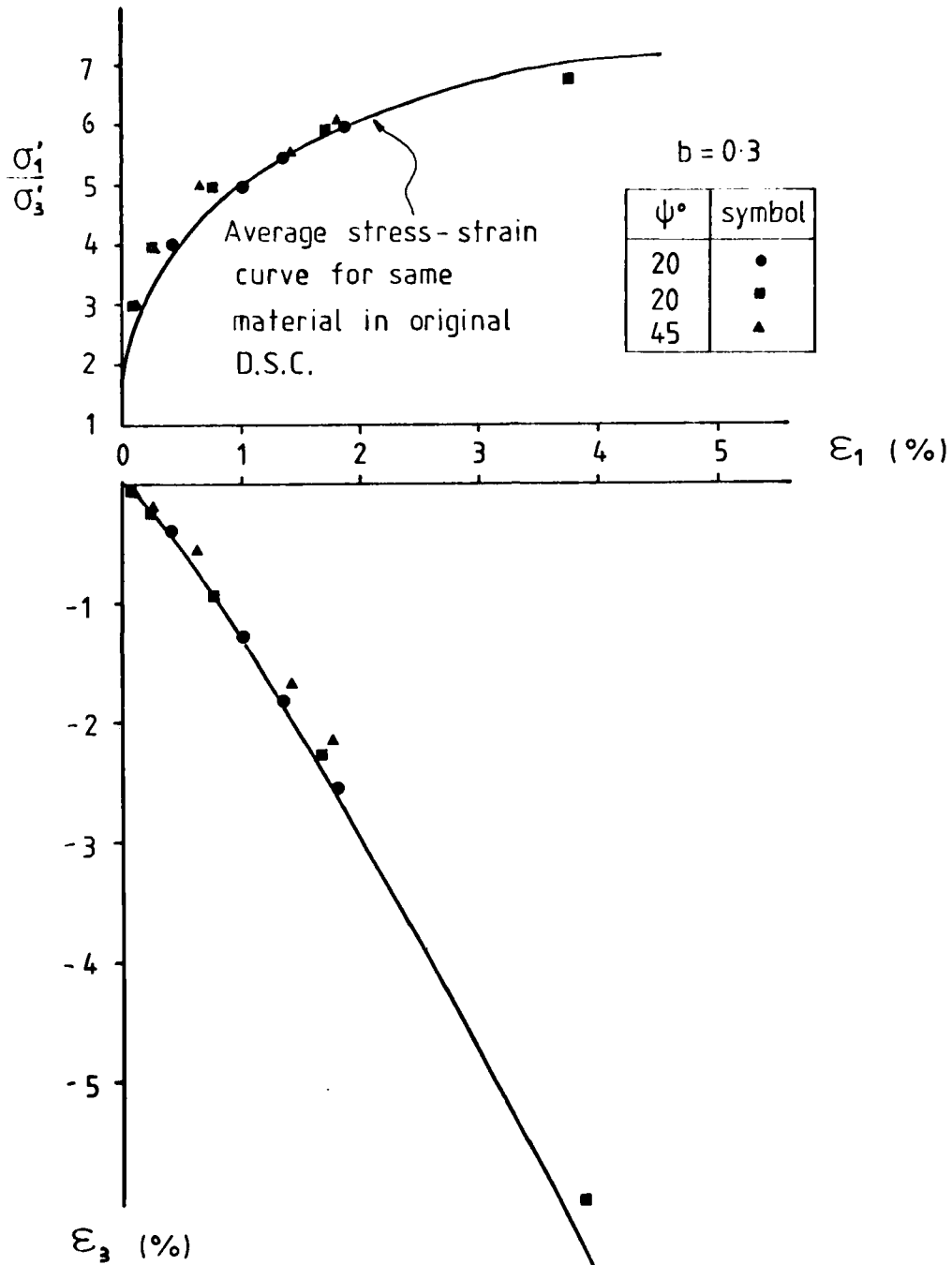
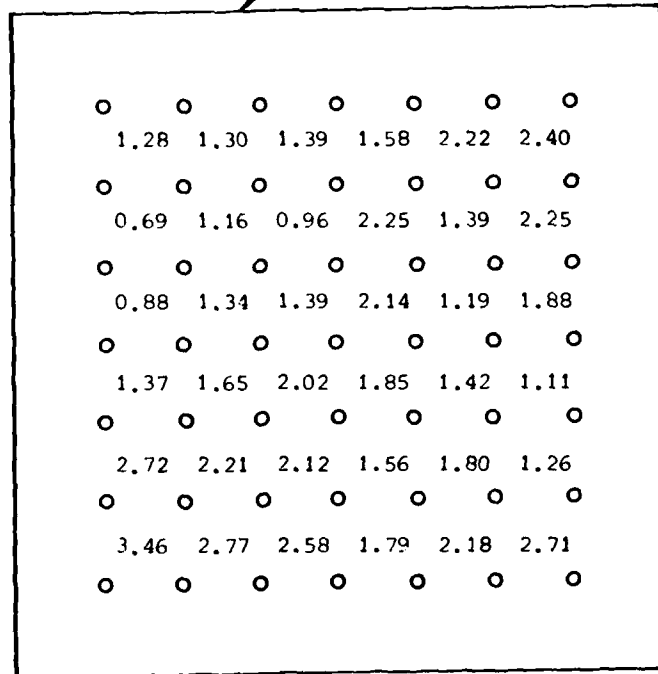

Figure 4a

Sample boundary



Average in area 1: 1.79% with standard deviation of 0.62%

Average in area 2: 1.65% with standard deviation of 0.41%

Average in area 3: 1.85% with standard deviation of 0.33%

$\epsilon_1$  distribution at  $R = 6$ ,  $\psi = 20^\circ$  test

Figure 4b

Sample boundary

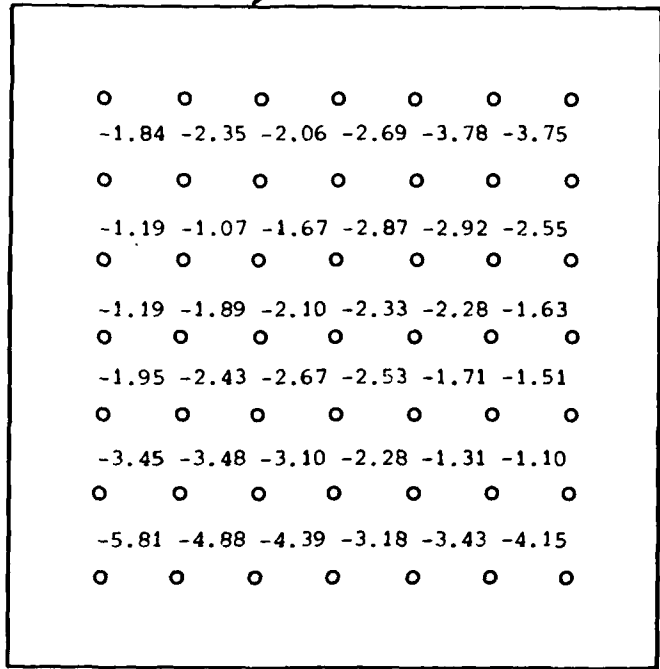

Average in area 1: -2.60% with standard deviation of 1.11%  
Average in area 2: -2.29% with standard deviation of 0.65%  
Average in area 3: -2.41% with standard deviation of 0.25%

$\epsilon_3$  distribution at  $R = 6, \psi = 20^\circ$  test

Figure 4c

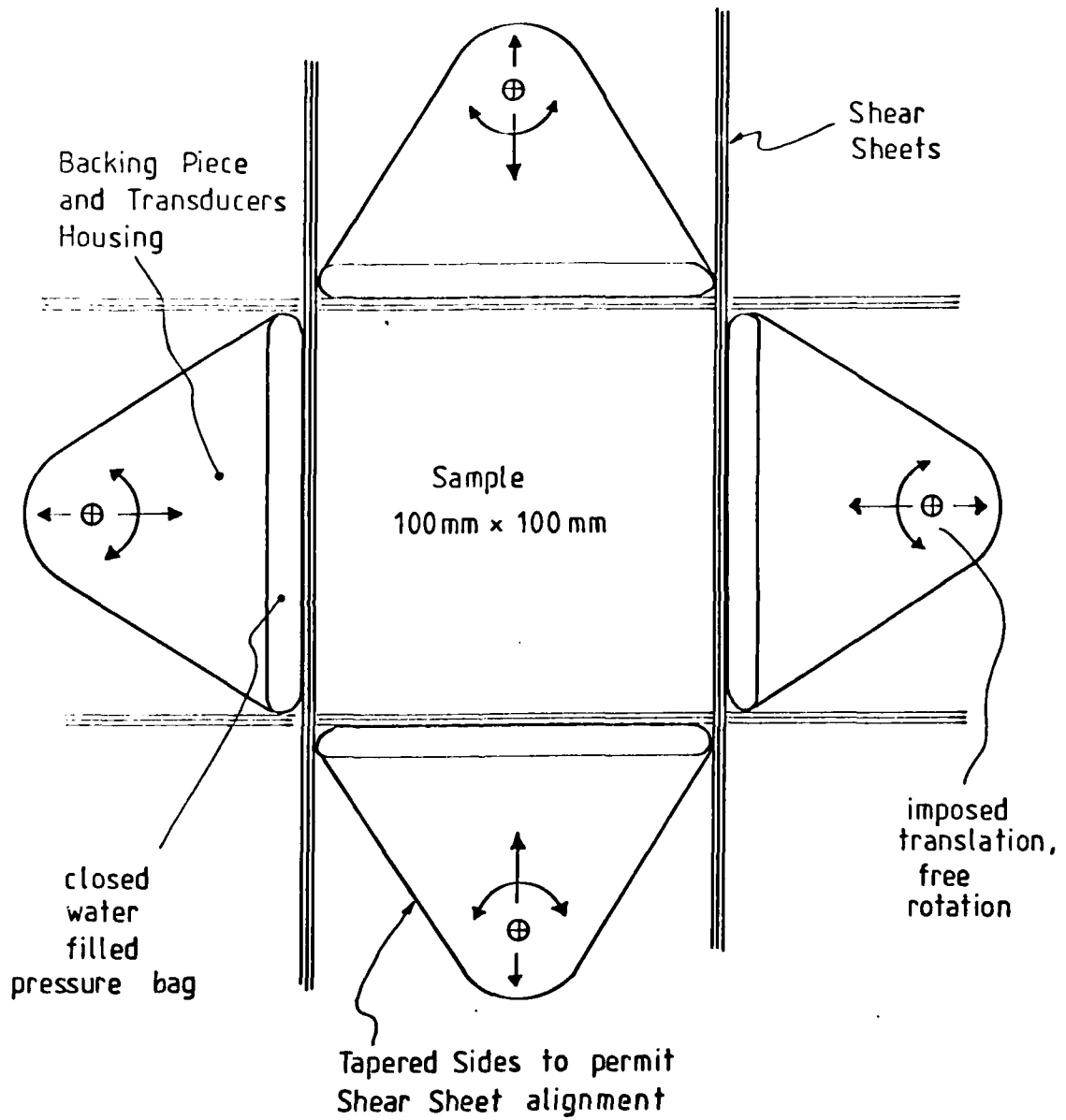

Figure 5

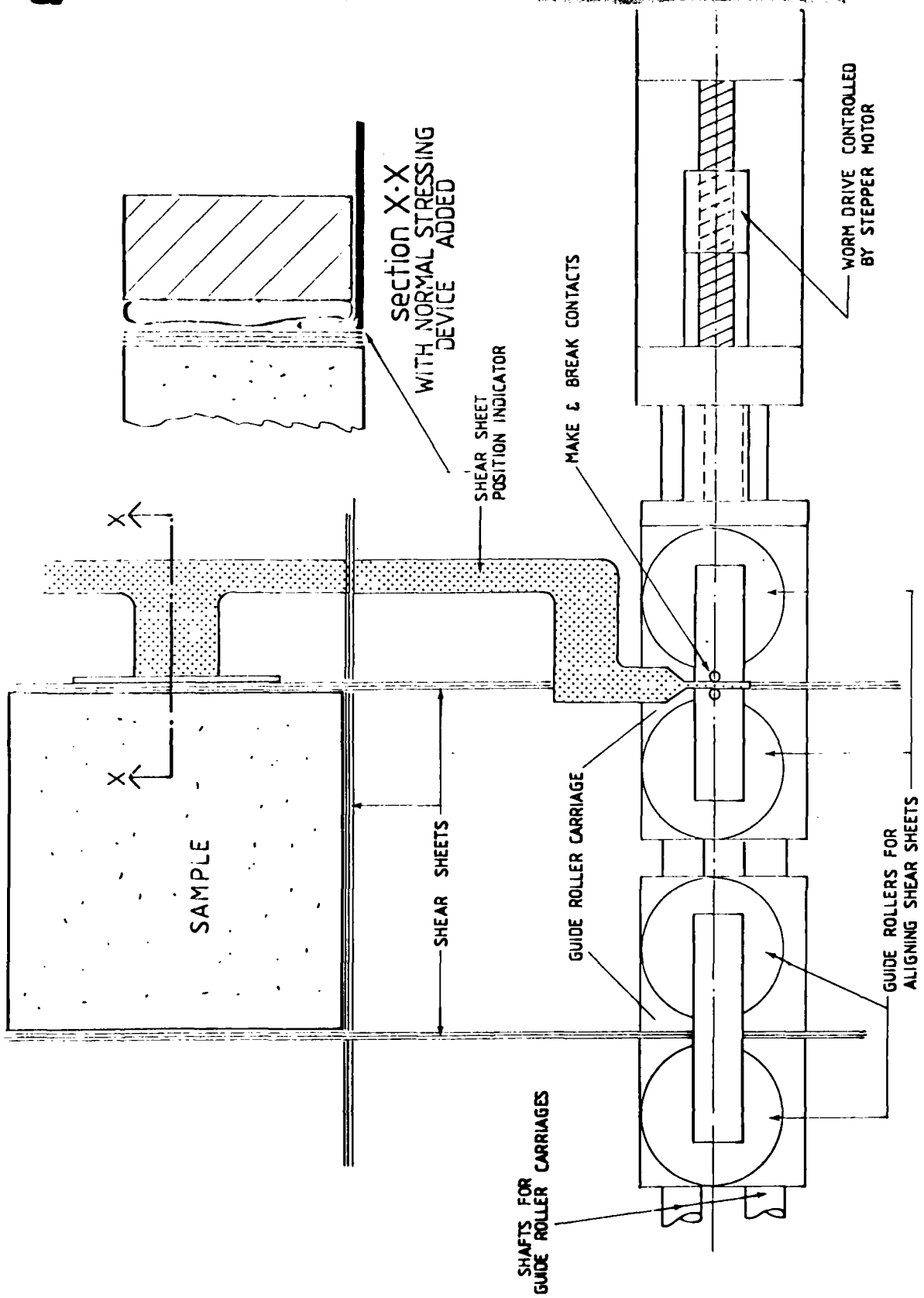

Figure 6

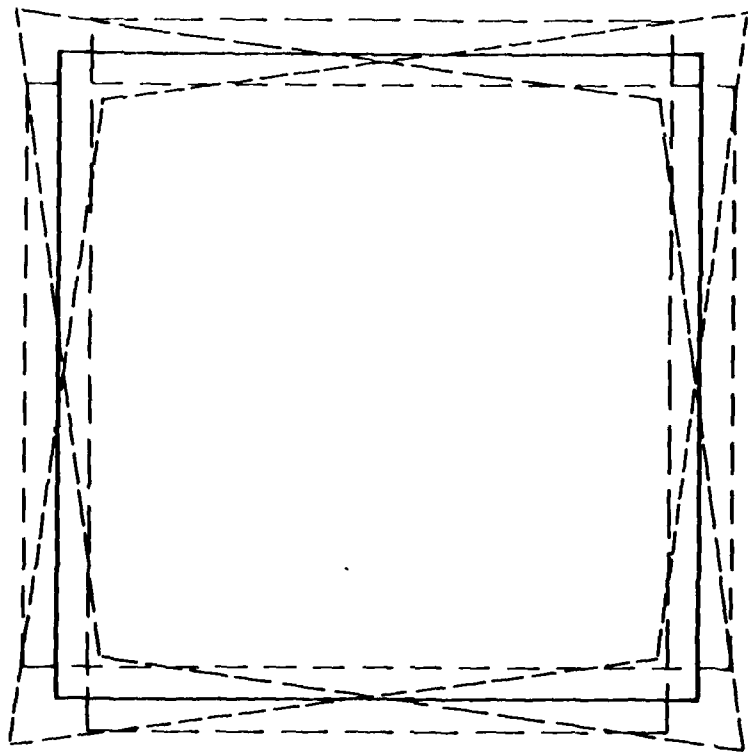

Figure 7

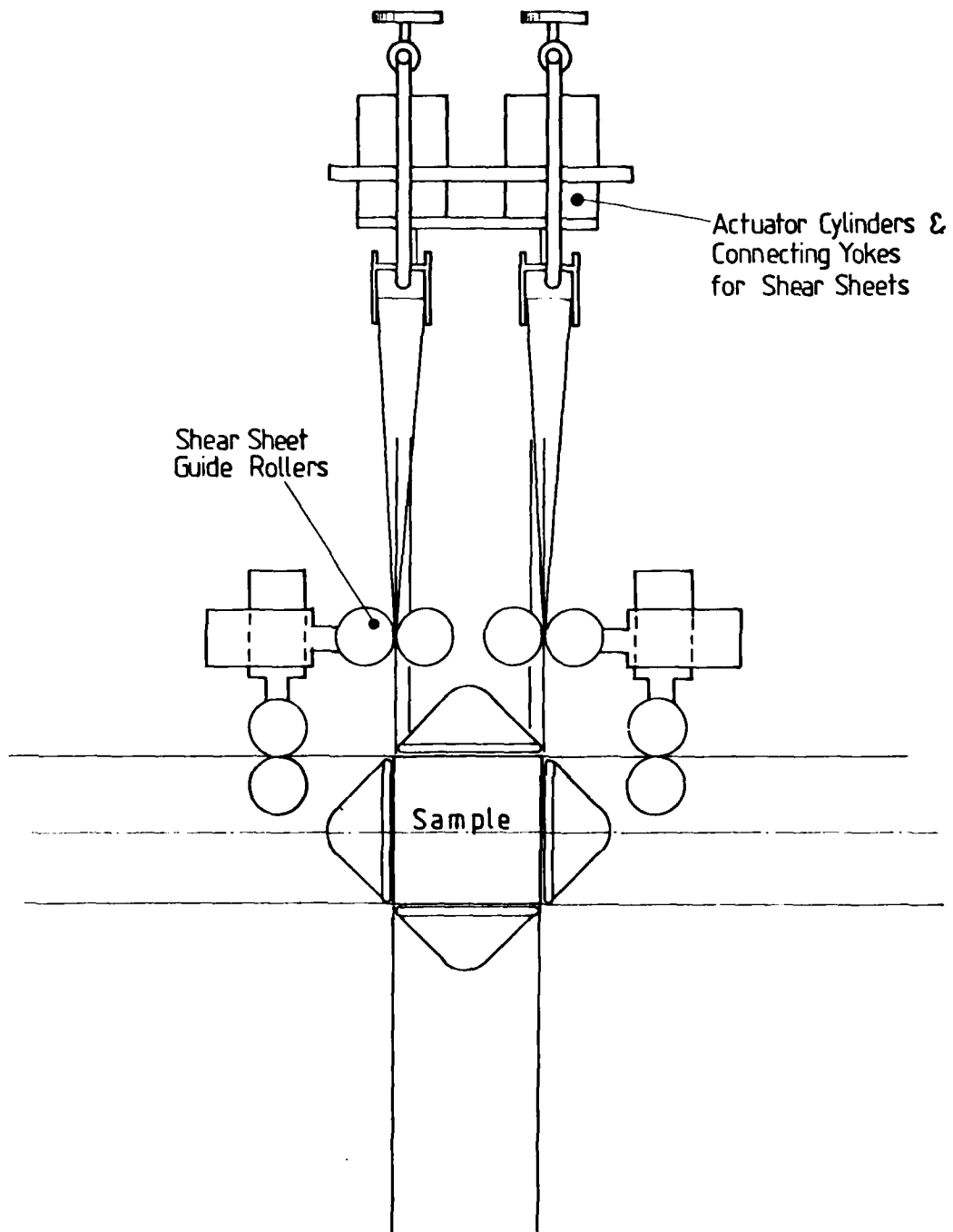
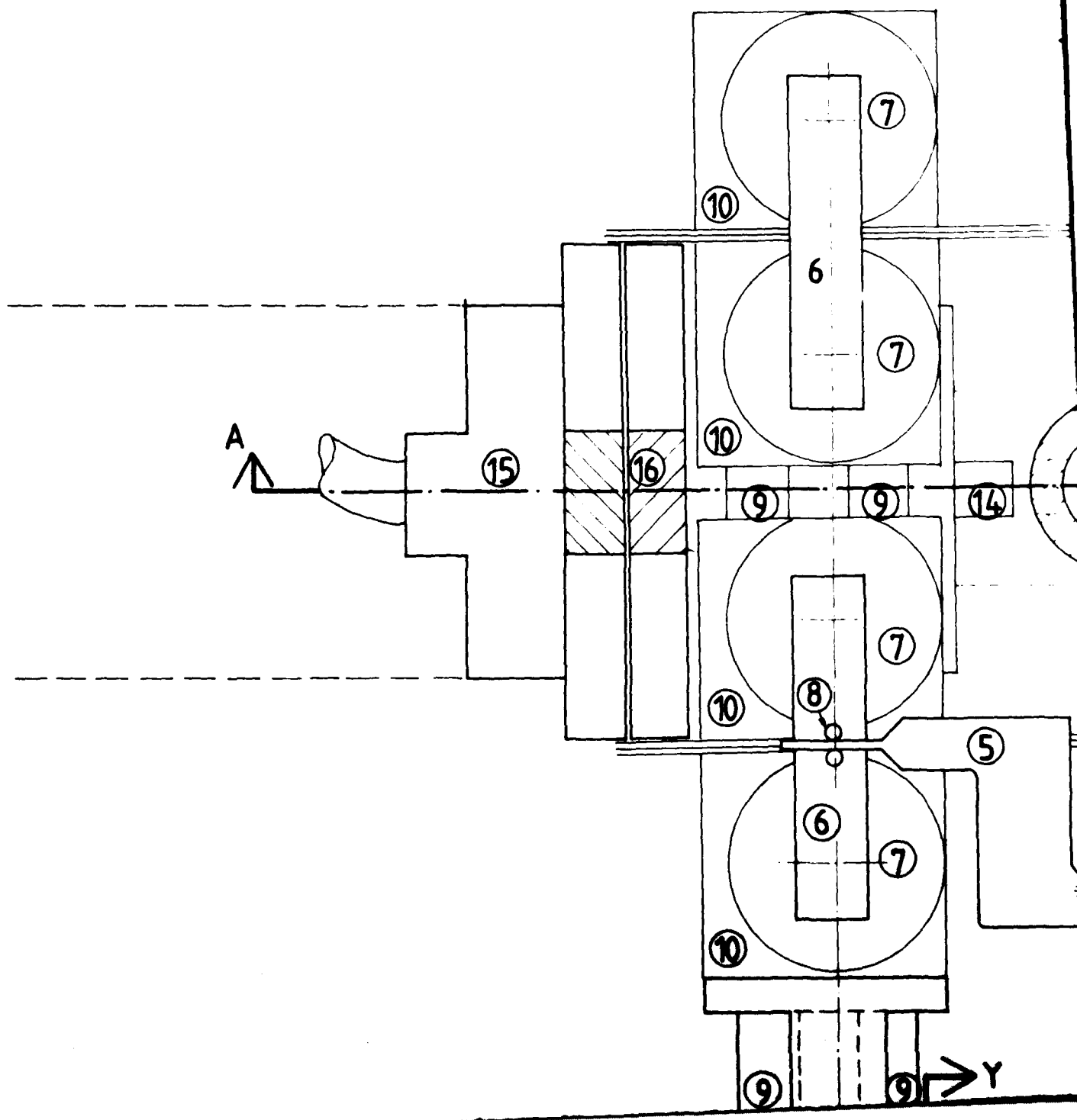

Figure 8

1



□

2

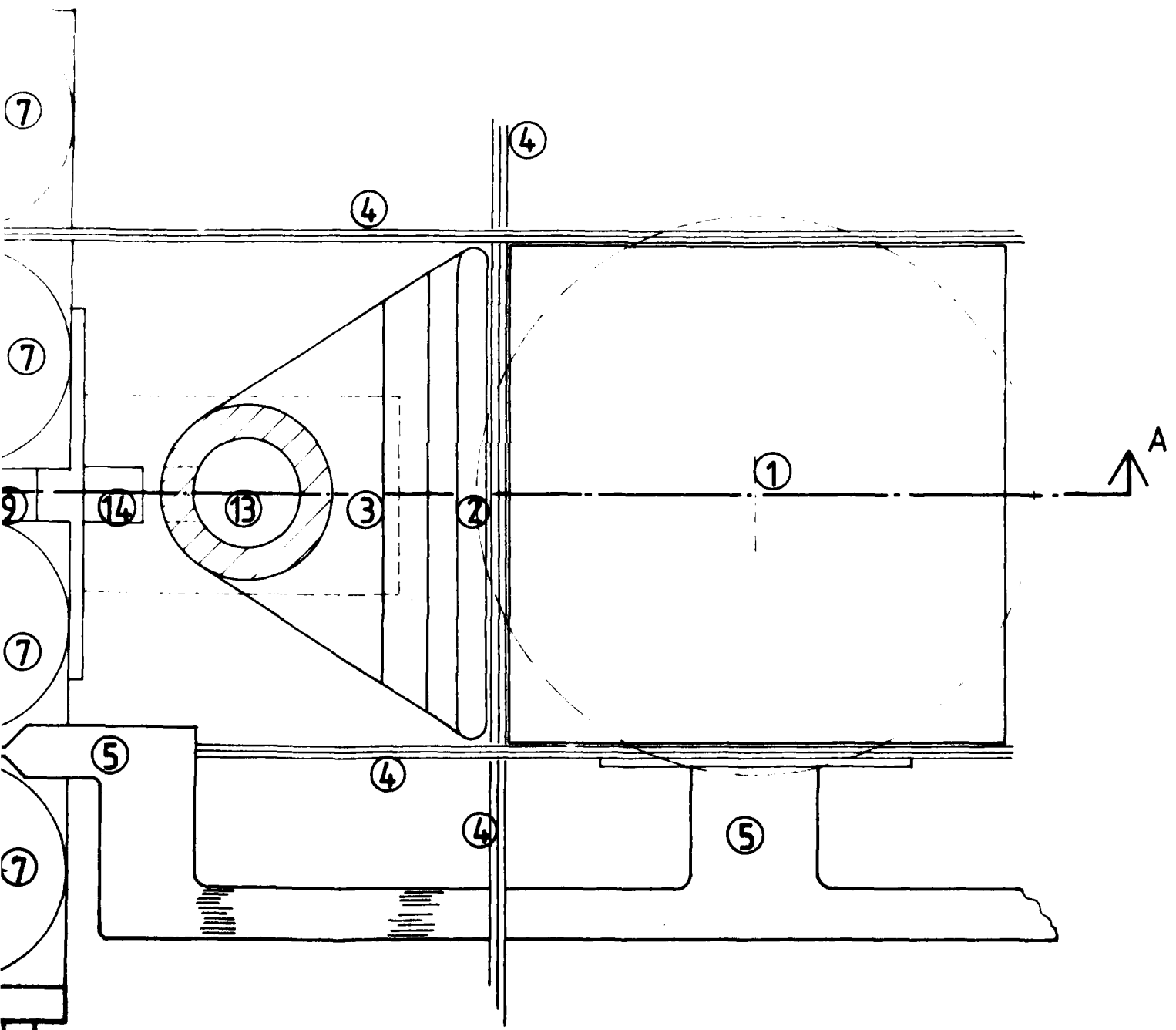

3

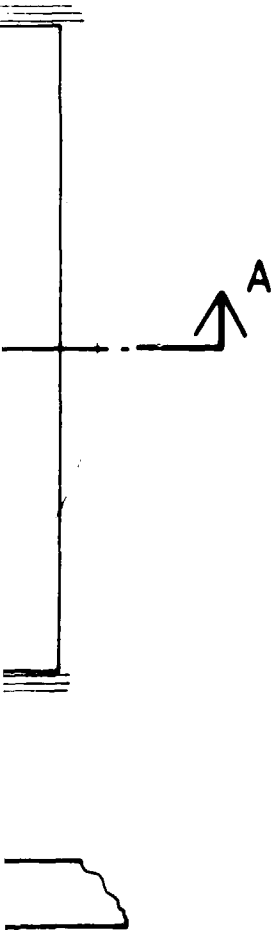

- 1 Soil Sample
- 2 Normal Stress Bag
- 3 " " " Backing Plate
- 4 Shear Sheets
- 5 Shear Sheet Position Indicator
- 6 Make & Break Contact Mounting
- 7 Shear Sheet Guide Rollers
- 8 Make & Break Contacts
- 9 Guide Roller Carriage Shafts
- 10 Guide Roller Carriages
- 11 Worm Drives for 10
- 12 Stepper Motor
- 13 Pressure Transducer Housing
- 14 Shaft of Actuator Cylinder
- 15 Actuator Cylinder

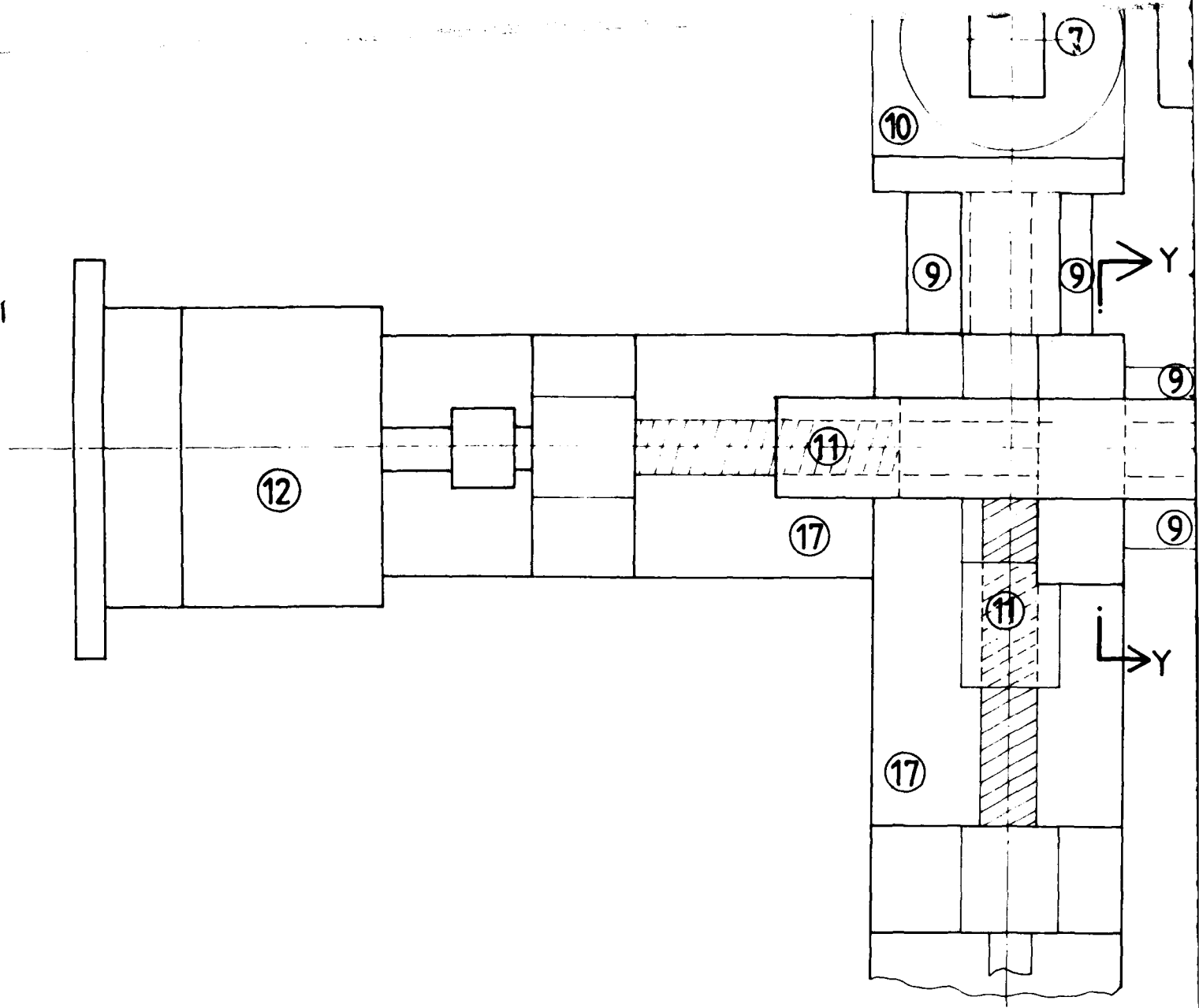

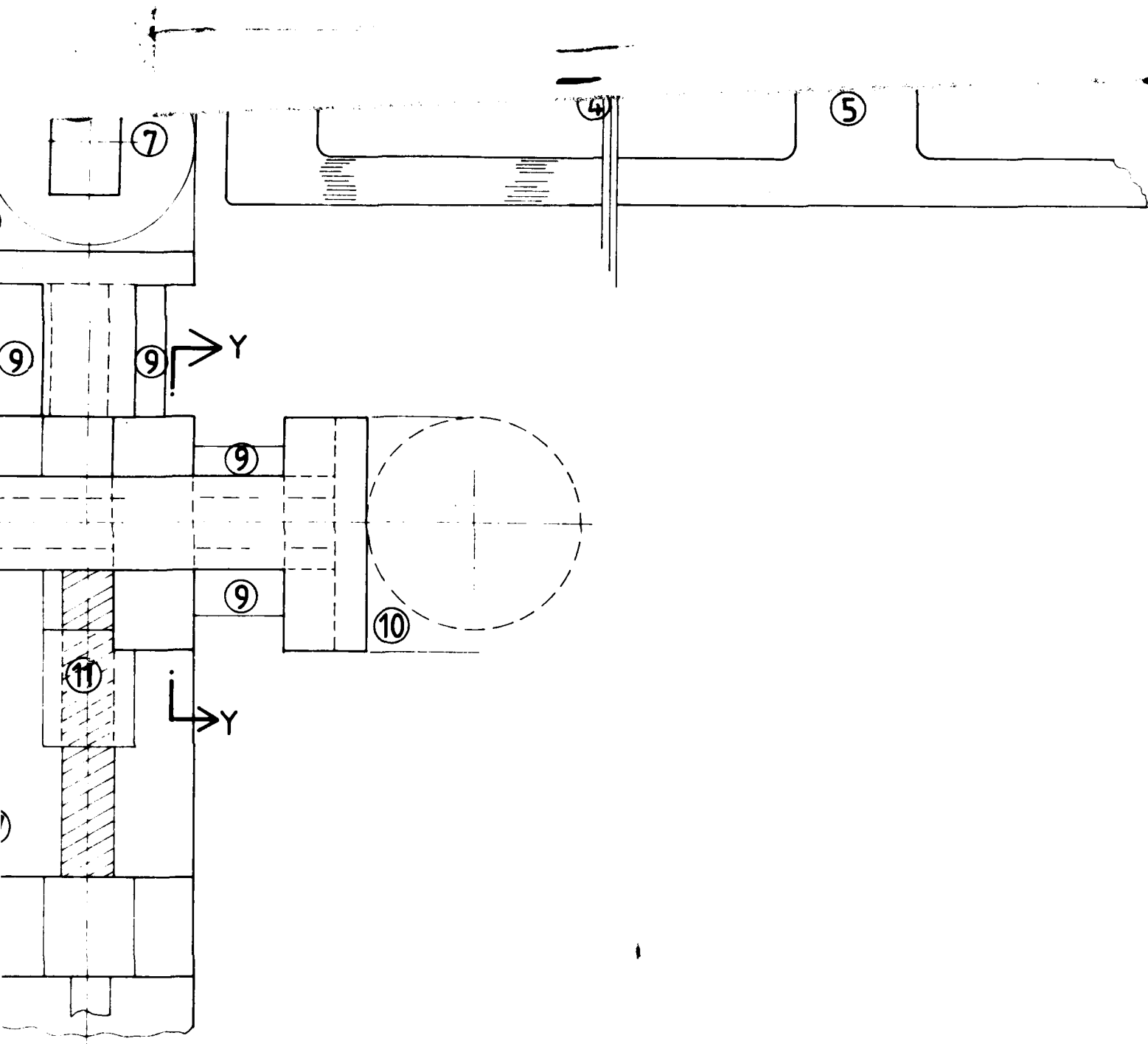

**FIG. 9 SECTION B-B**

(SEE FIGURE 11)

- 9 Guide Roller Carriage Shafts
- 10 Guide Roller Carriages
- 11 Worm Drives for 10
- 12 Stepper Motor
- 13 Pressure Transducer Housing
- 14 Shaft of Actuator Cylinder
- 15 Actuator Cylinder
- 16 Central Connecting Flanges of Actuator Cylinders
- 17 Mounting Block for 9 , 11 , 12

Full Scale, but dimensions may  
be changed subsequently

12-9-1985

-B

G

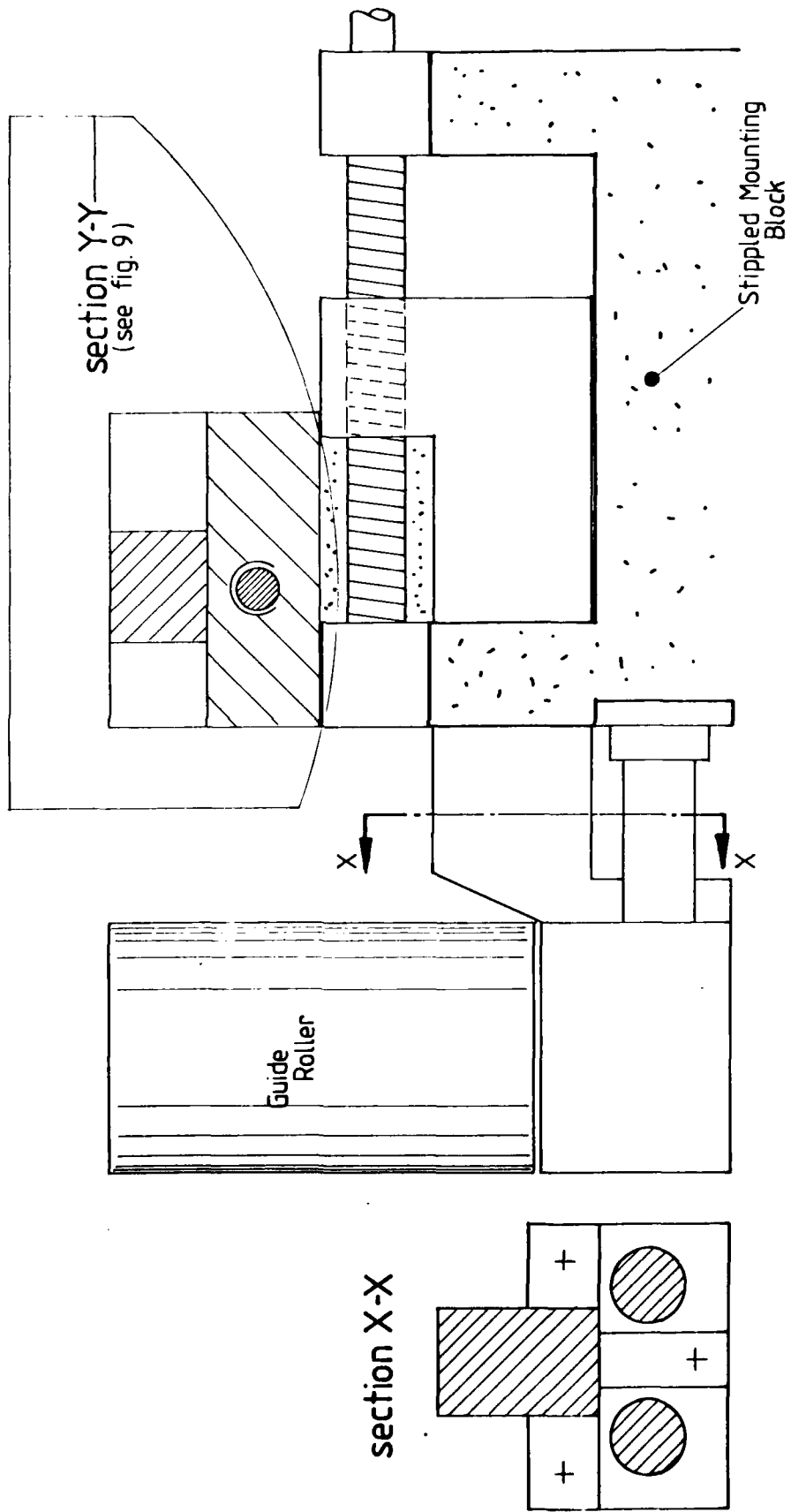
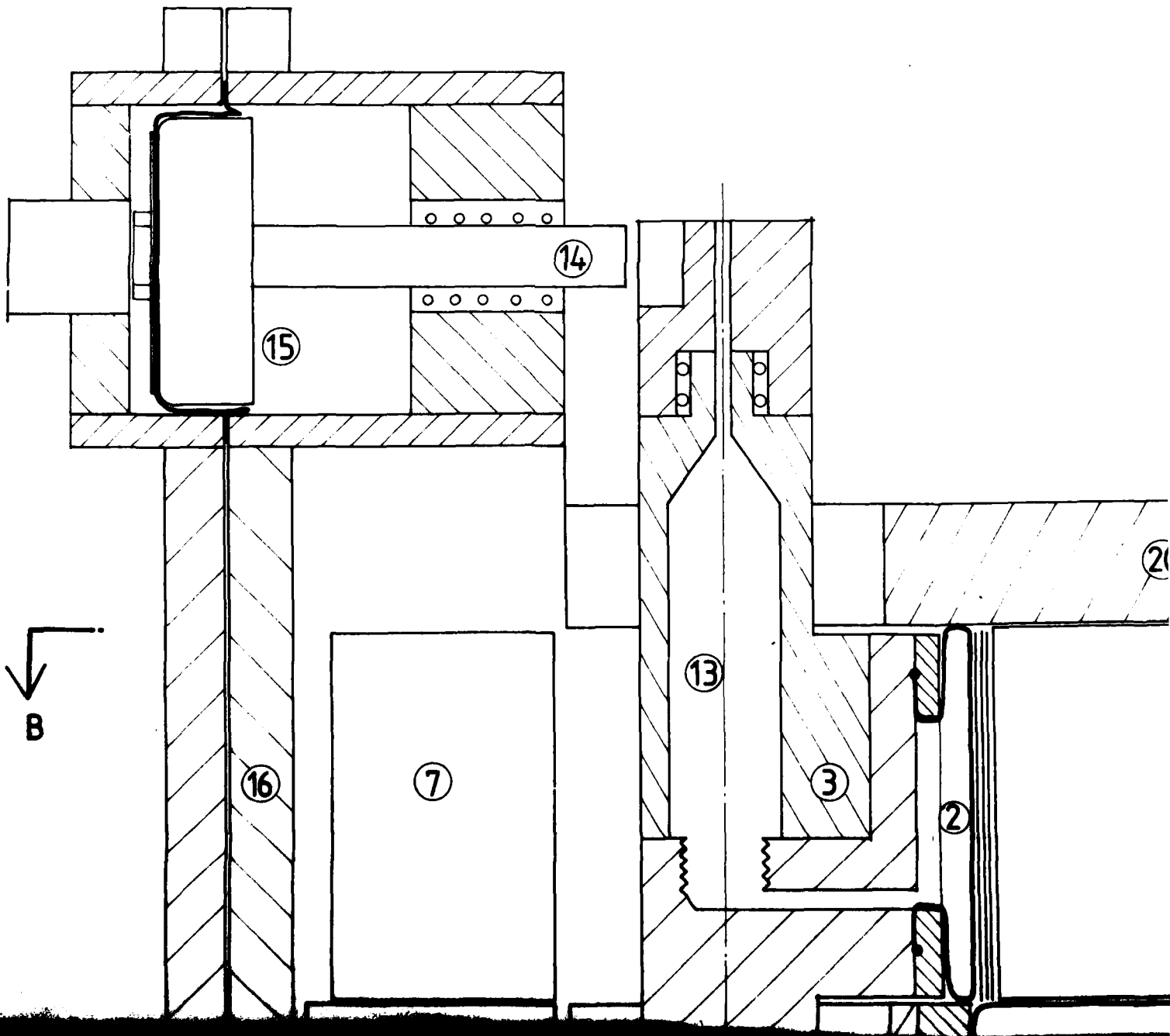
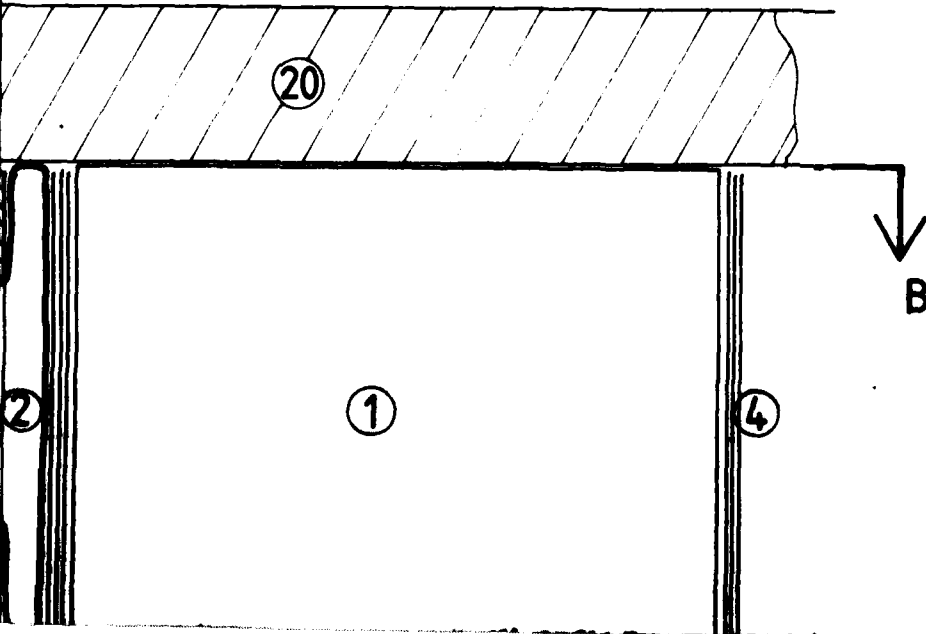

Figure 10



1 2



- 1 Soil Sampl
- 2 Normal Str
- 3 "
- 4 Shear She
- 7 Shear She
- 9 Guide Rol
- 10 Guide Roll
- 13 Pressure
- 14 Shaft of
- 15 Actuator
- 16 Central C  
Actu
- 18 Intermedia
- 19 Bottom P
- 20 Top Pla

- 1 Soil Sample
- 2 Normal Stress Bag
- 3 " " " Backing Plate
- 4 Shear Sheets
- 7 Shear Sheet Guide Rollers
- 9 Guide Roller Carriage Shafts
- 10 Guide Roller Carriages
- 13 Pressure Transducer Housing
- 14 Shaft of Actuator Cylinder
- 15 Actuator Cylinder
- 16 Central Connecting Flanges of  
Actuator Cylinders
- 18 Intermediate P. Stress Bag
- 19 Bottom Plate
- 20 Top Plate

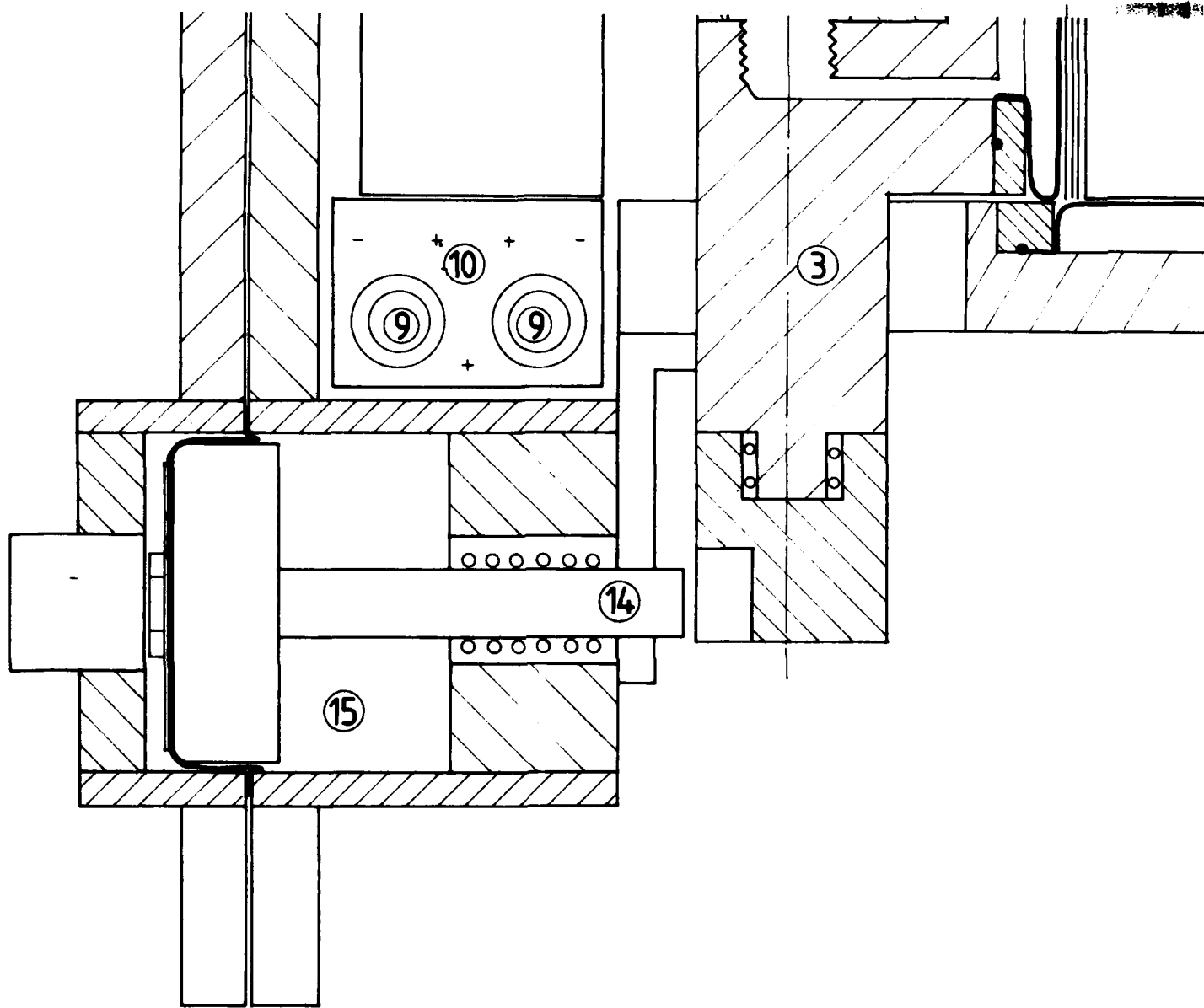

4

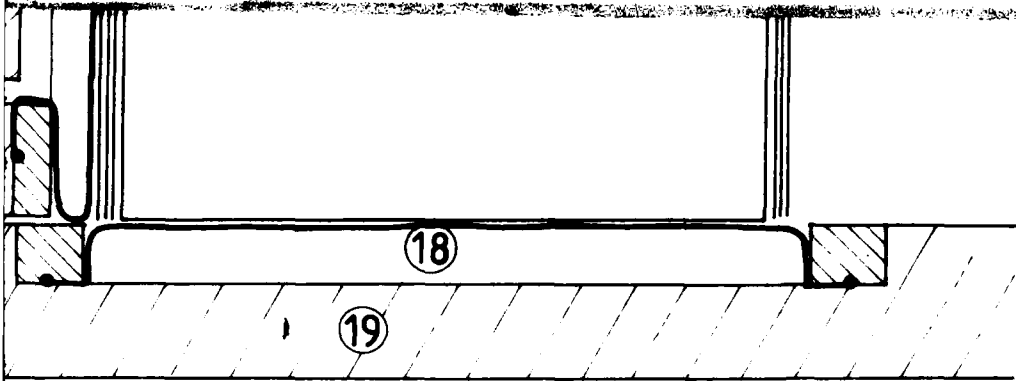

19 Bottom  
20 Top P

Full Scale, but  
changed subsequent  
12-9-1985

FIG. 11 SECTION A-A  
(SEE FIGURE 9)

5

- 19 Bottom Plate
- 20 Top Plate



Full Scale, but dimensions may be  
changed subsequently.  
12-9-1985

# SECTION A-A

FIGURE 9 )

6

DATE  
LIMED  
-8